

Servicekarte / Service card

Modelname / Model name Kiel Bettrahmen / Bed frame 180x200	Artikelnummer / article number 1002612	Ausführung / Version Kiefer massiv, gelaugt Solid pine, leached
---	--	---

71903

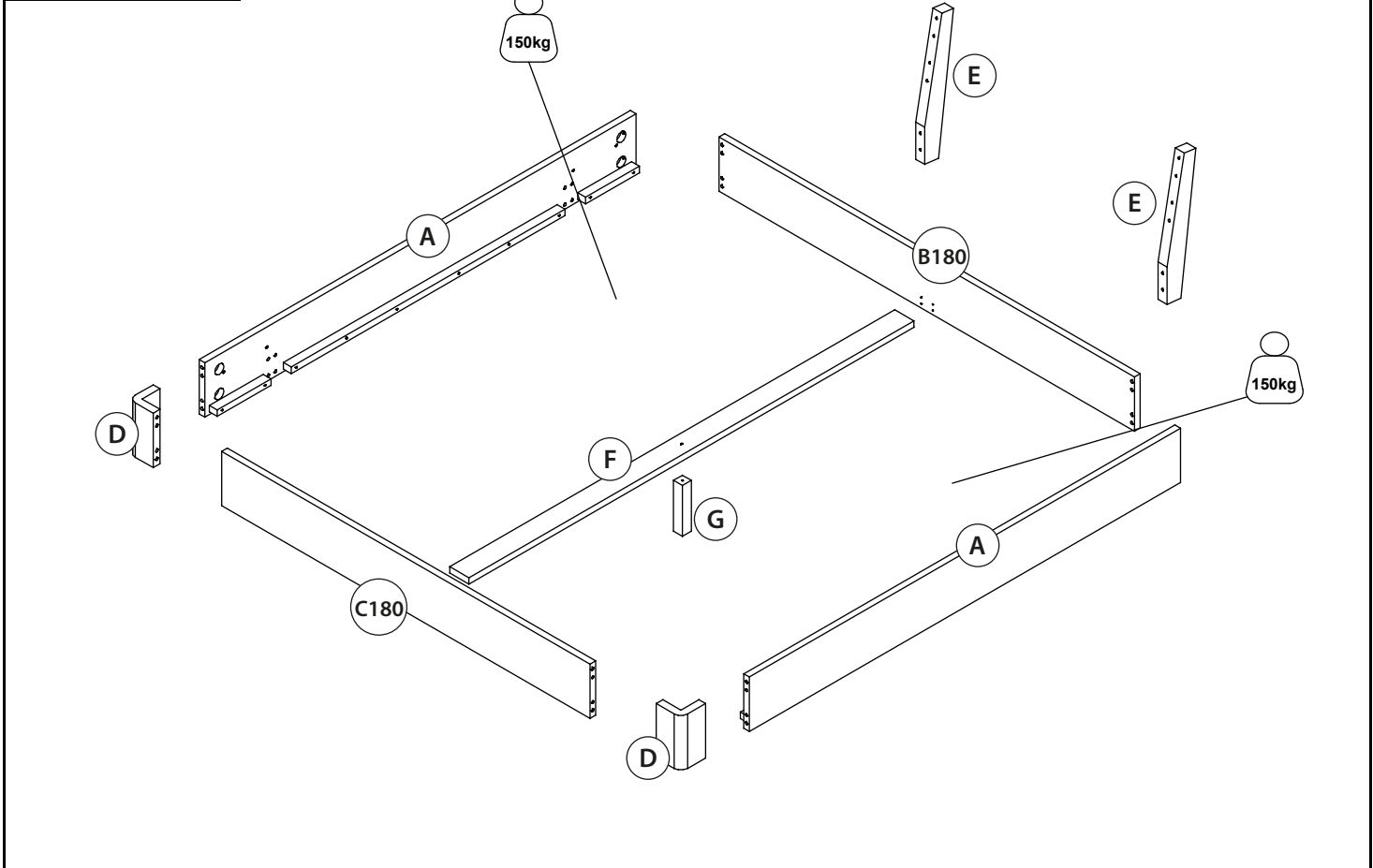

1 M6x60 x8	2 Ø10x50 x12	3 x12	4 x12	5 3,5x20 x14	7x50 x1
6 x2	7 x2	8 SW4 x1	9 x1	10 M6x25 x16	11 16mm x16

Grund der Beanstandung: reason for complaint: Name: name: Strasse: street: Postleitzahl: postal code: Telefonnummer: telephone number:			
			HausNr.: house number:
		Ort: place:	

DE: Sehr geehrter Kunde, Sehr geehrte Kundin!

Fehlt Ihnen ein Beschlagteil oder ist es Defekt? Kein Problem! Nutzen Sie unsere Servicekarte!

Unser Direkt-Bestellservice für fehlende/defekte Beschlagteile:

Kontaktieren Sie uns telefonisch unter Tel. **+49 7452/84822-0** oder senden Sie uns eine E-Mail an reklamation@imc.nagold.de.

Bitte geben Sie dabei folgende Pflicht-Informationen an: -> Auftragsnummer, Artikelnummer, Nummer des Beschlagteils, fehlende/defekte Menge, und den Grund der Beanstandung, ob es sich um ein defektes oder fehlendes Beschlagteil handelt. Tragen Sie die benötigte Menge ein. Mailen Sie uns die vollständig ausgefüllte Servicekarte zu, um die Bearbeitung zu ermöglichen. Für andere Beanstandungen / Beschädigungen an Ihrem Möbelstück wenden Sie sich bitte direkt an Ihr Möbelhaus.

EN: Dear customer!

Are you missing a fitting part or is it defective? No problem! Use our service card!









Our direct ordering service for missing/defective fitting parts:

Contact us by telephone on **+49 7452/84822-0** or send us an e-mail to reklamation@imc.nagold.de.

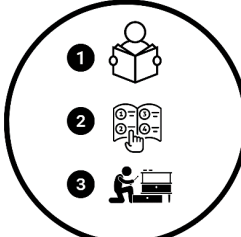
Please include the following mandatory information: -> Order number, article number, number of the fitting part, missing/defective quantity, and the reason for the complaint, whether it is a defective or missing fitting part. Enter the required quantity.

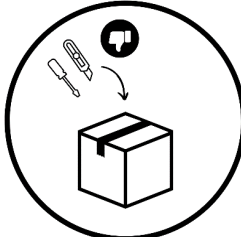
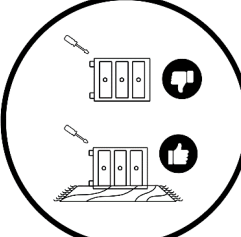
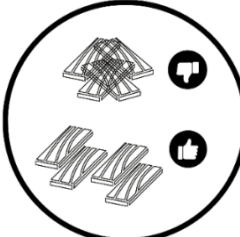
Mail us the completed service card to enable processing.

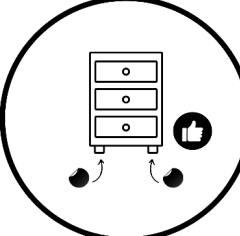
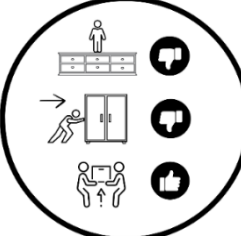
For other complaints/damage to your furniture, please contact your furniture store directly.

		
		
		
		



Servicekarte / Service card

Modelname / Model name	Artikelnummer / article number	Ausführung / Version
Kiel		
Holzkopfteil / wooden headboard 180	1002614	Kiefer massiv, gelaugt / Solid pine, leached
Holzkopfteil / wooden headboard 180	1002609	Kiefer massiv weiß gewachst / Solid pine, white waxed
Stoffkopfteil / fabric headboard 180	1002610	Bezug Anthrazit / cover anthracite

71903

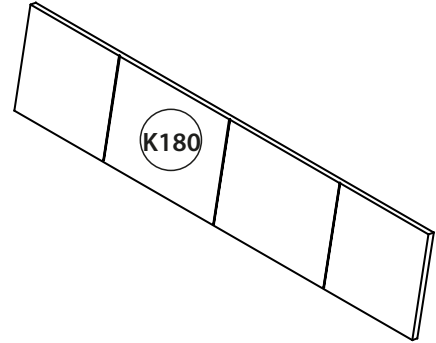
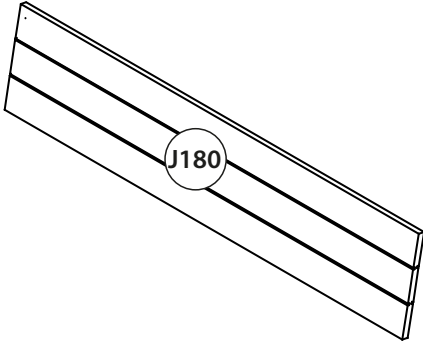

Modelname / Model name	Artikelnummer / article number	Ausführung / Version
Kiel		
Holzkufer / wooden skids 180	1002613	Kiefer massiv, gelaugt / Solid pine, leached
Holzkufer / wooden skids 180	1002607	Kiefer massiv weiß gewachst / Solid pine, white waxed
Metallkufer / metal skid 180	1002608	Metall schwarz / Metal black

71903

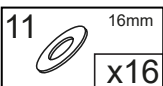
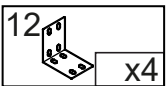
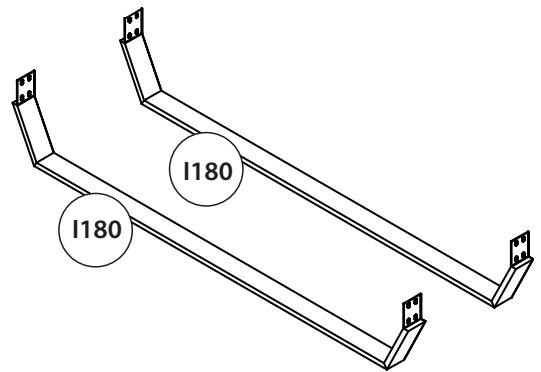
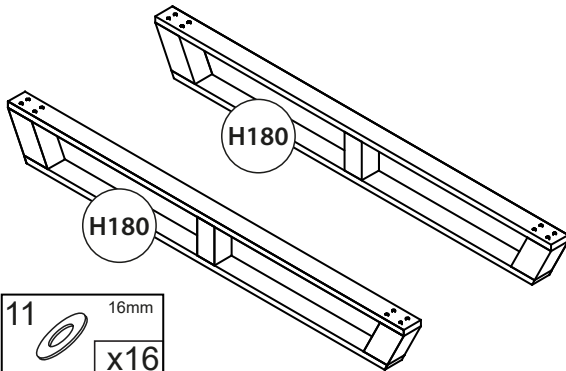

Grund der Beanstandung:

reason for complaint:

Name:

name:

Strasse:

street:

Postleitzahl:

postal code:

Telefonnummer:

telephone number:

Ort:

place:

HausNr.:

house number:

DE: Sehr geehrter Kunde, Sehr geehrte Kundin!

Fehlt Ihnen ein Beschlagteil oder ist es Defekt? Kein Problem! Nutzen Sie unsere Servicekarte!

Unser Direkt-Bestellservice für fehlende/defekte Beschlagteile:

Kontaktieren Sie uns telefonisch unter Tel. **+49 7452/84822-0** oder senden Sie uns eine E-Mail an reklamation@imc.nagold.de.

Bitte geben Sie dabei folgende Pflicht-Informationen an: -> Auftragsnummer, Artikelnummer, Nummer des Beschlagteils, fehlende/defekte Menge, und den Grund der Beanstandung, ob es sich um ein defektes oder fehlendes Beschlagteil handelt. Tragen Sie die benötigte Menge ein. Mailen Sie uns die vollständig ausgefüllte Servicekarte zu, um die Bearbeitung zu ermöglichen. Für andere Beanstandungen / Beschädigungen an Ihrem Möbelstück wenden Sie sich bitte direkt an Ihr Möbelhaus.

EN: Dear customer!

Are you missing a fitting part or is it defective? No problem! Use our service card!

Our direct ordering service for missing/defective fitting parts:

Contact us by telephone on **+49 7452/84822-0** or send us an e-mail to reklamation@imc.nagold.de.

Please include the following mandatory information: -> Order number, article number, number of the fitting part, missing/defective quantity, and the reason for the complaint, whether it is a defective or missing fitting part. Enter the required quantity.

Mail us the completed service card to enable processing.

For other complaints/damage to your furniture, please contact your furniture store directly.

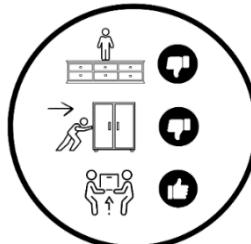
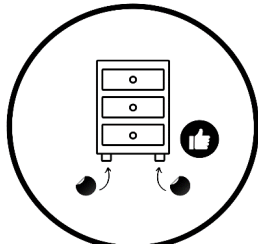
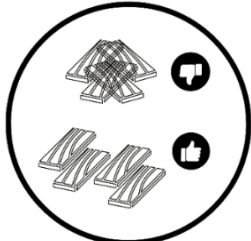
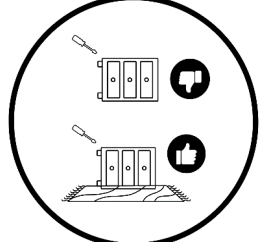
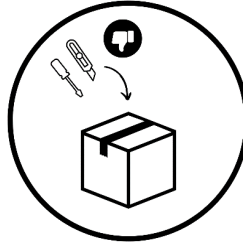
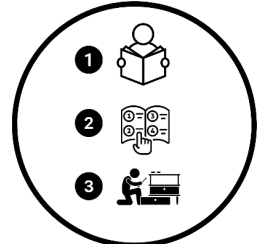

BETT KIEL

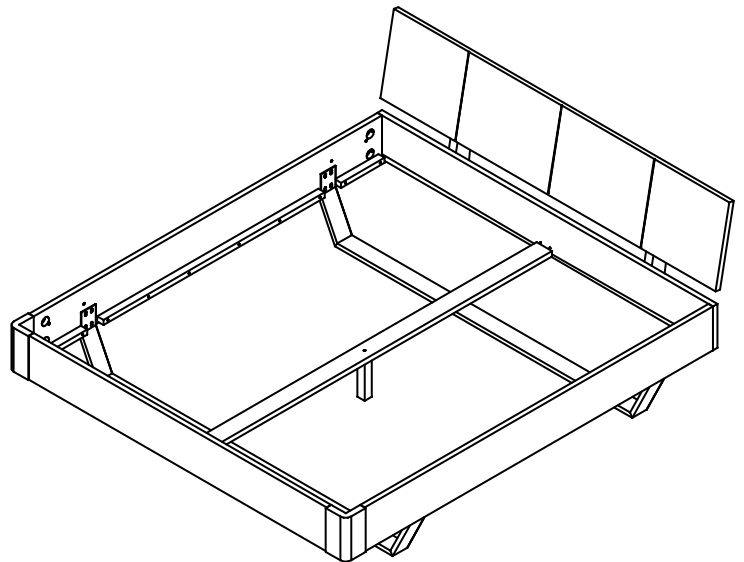
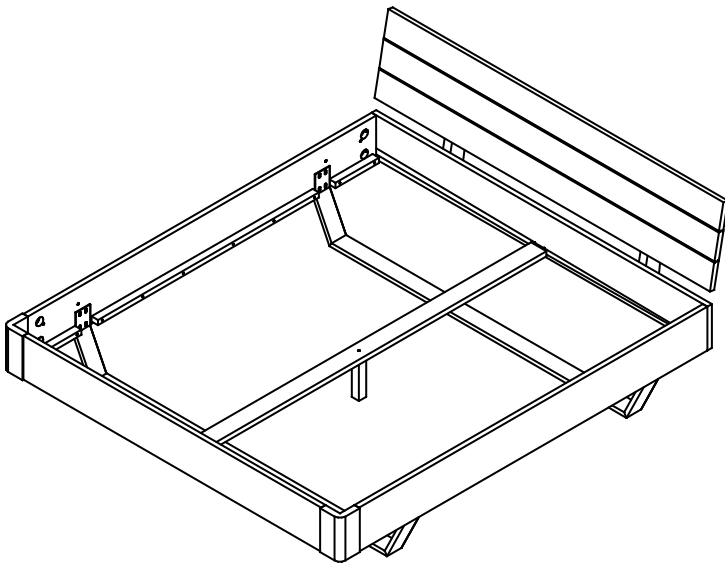
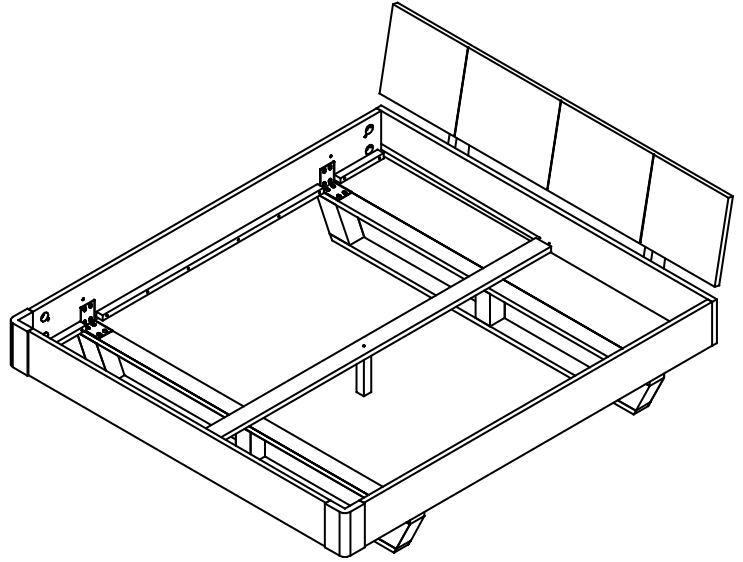
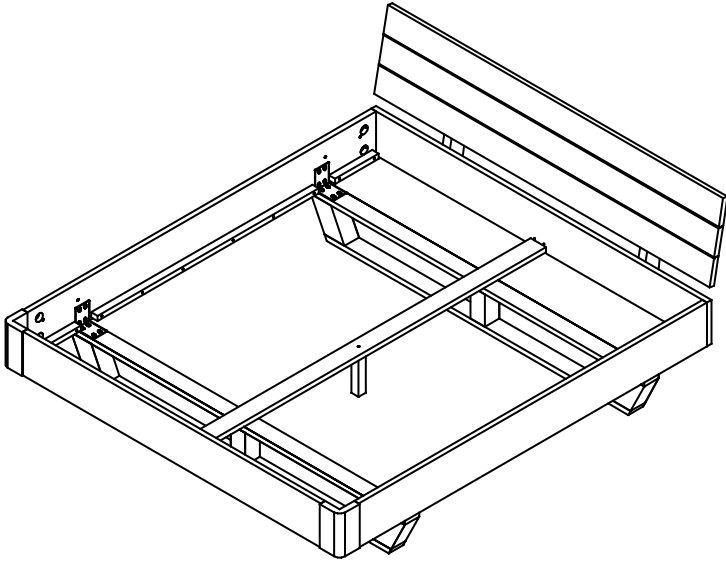

Aufbauzeit - 40 Minuten



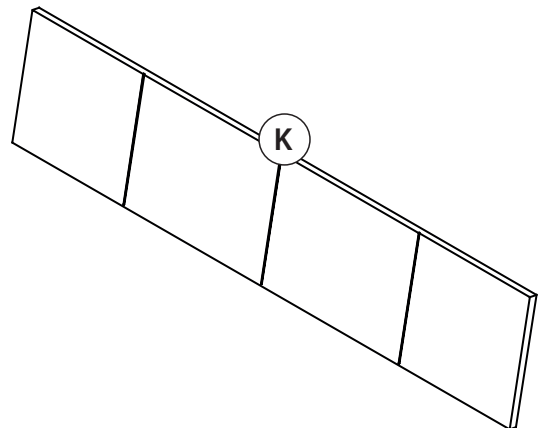
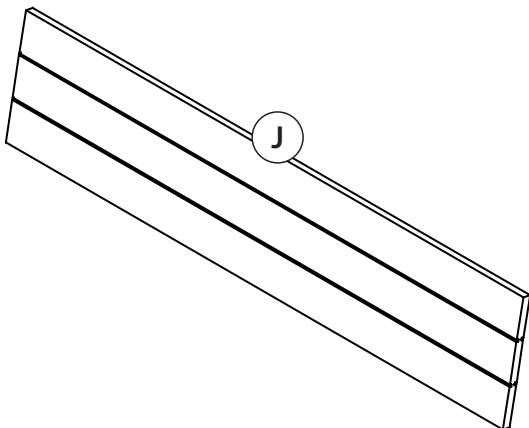
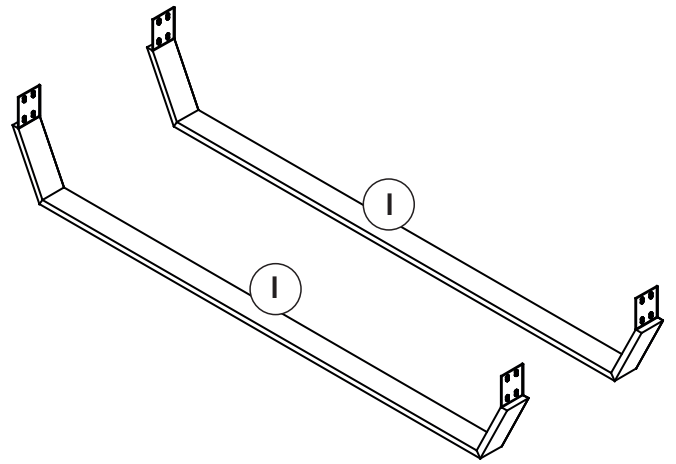
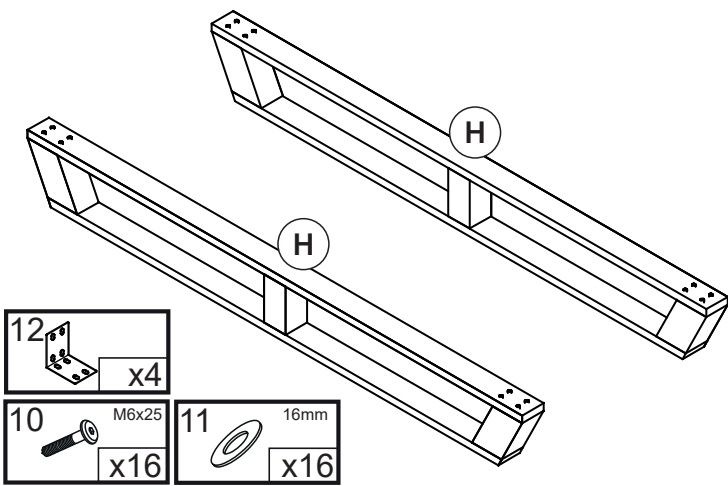
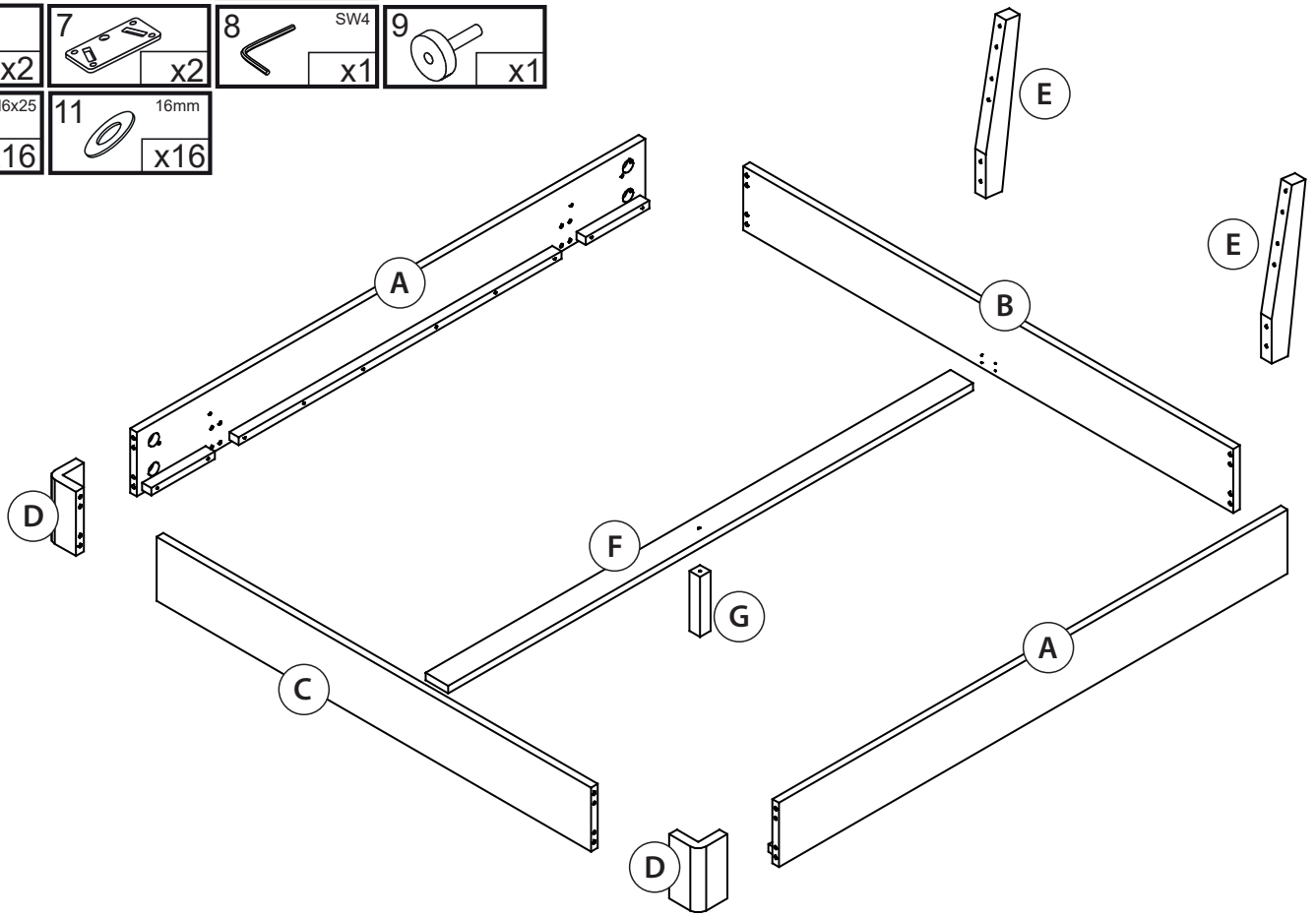
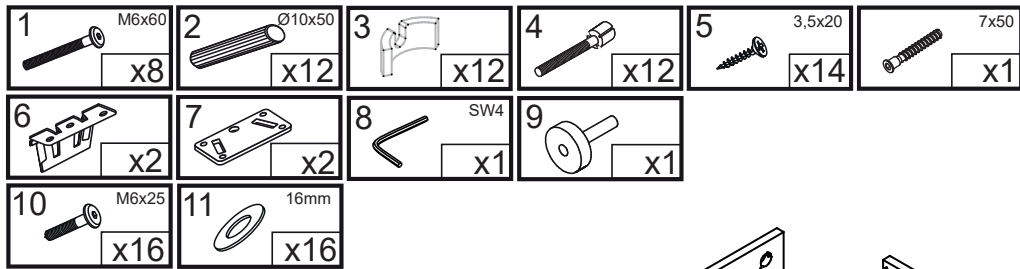

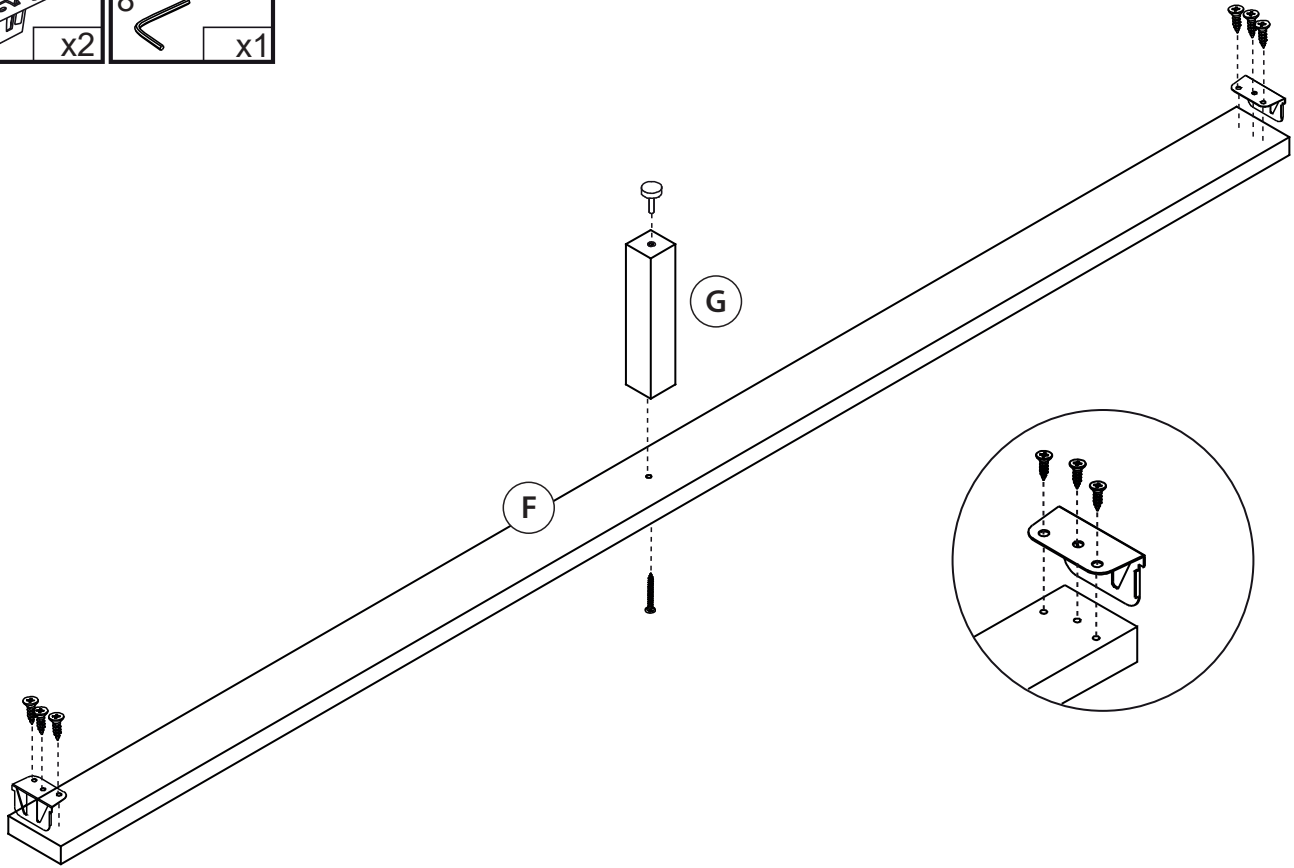
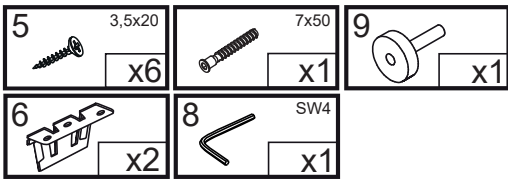

1

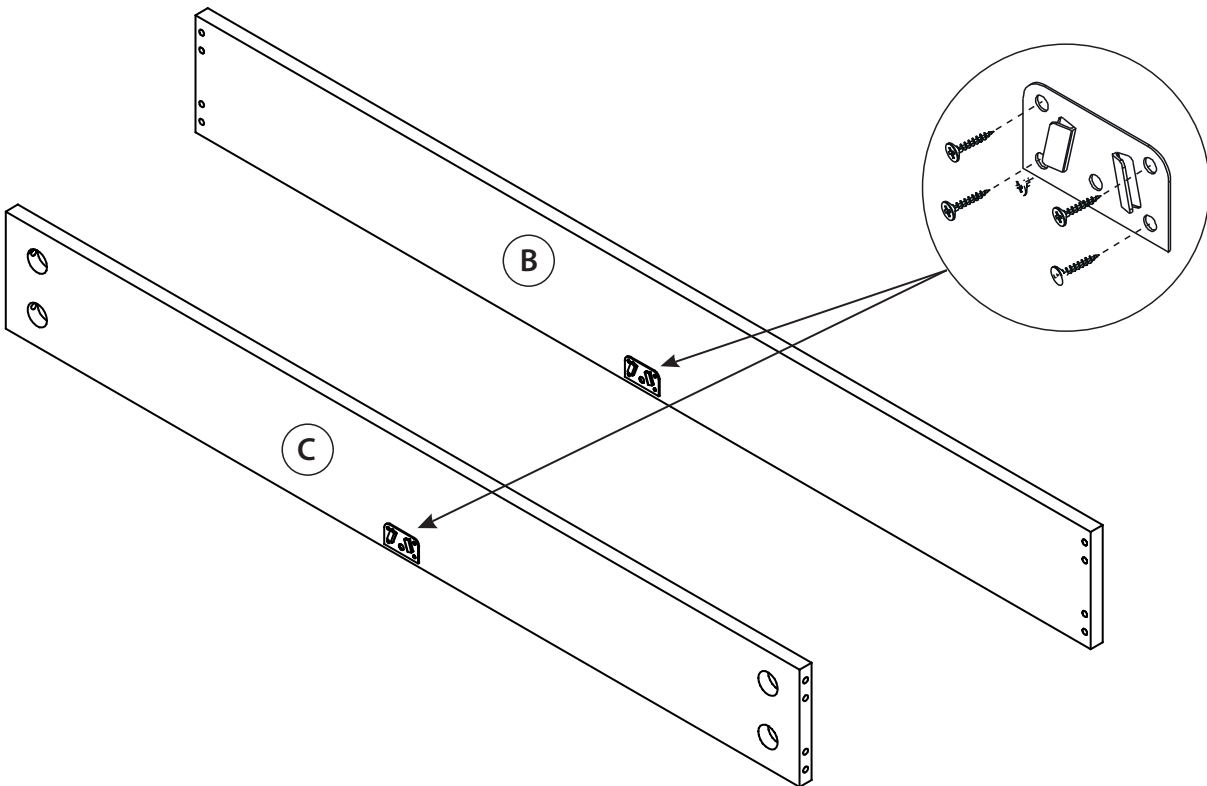
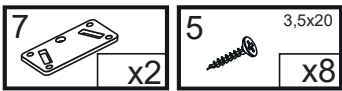

2

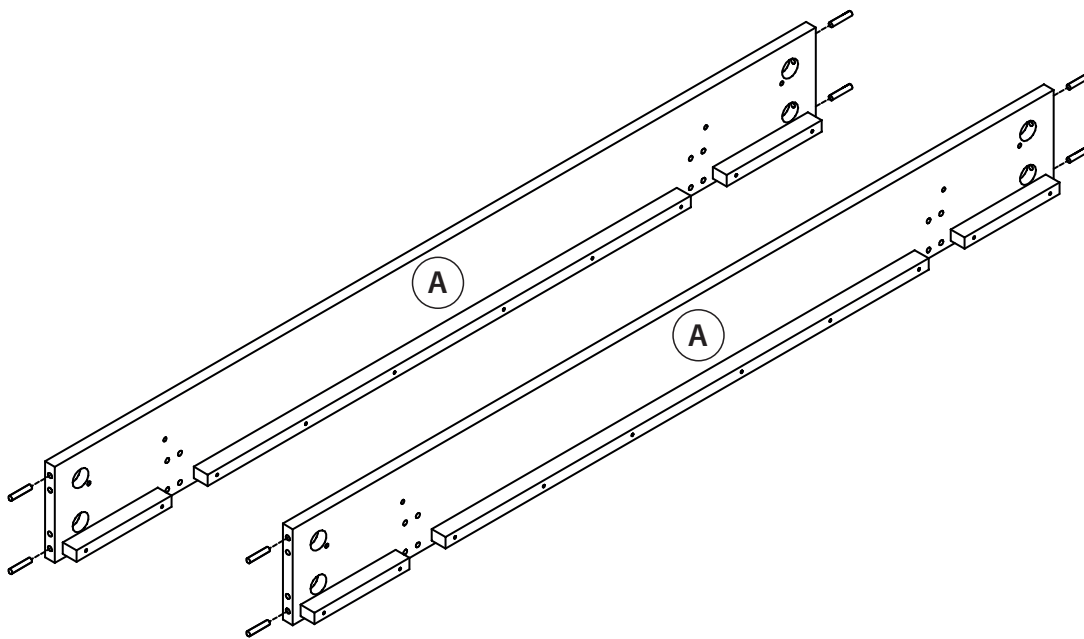
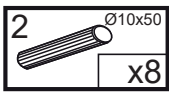

3

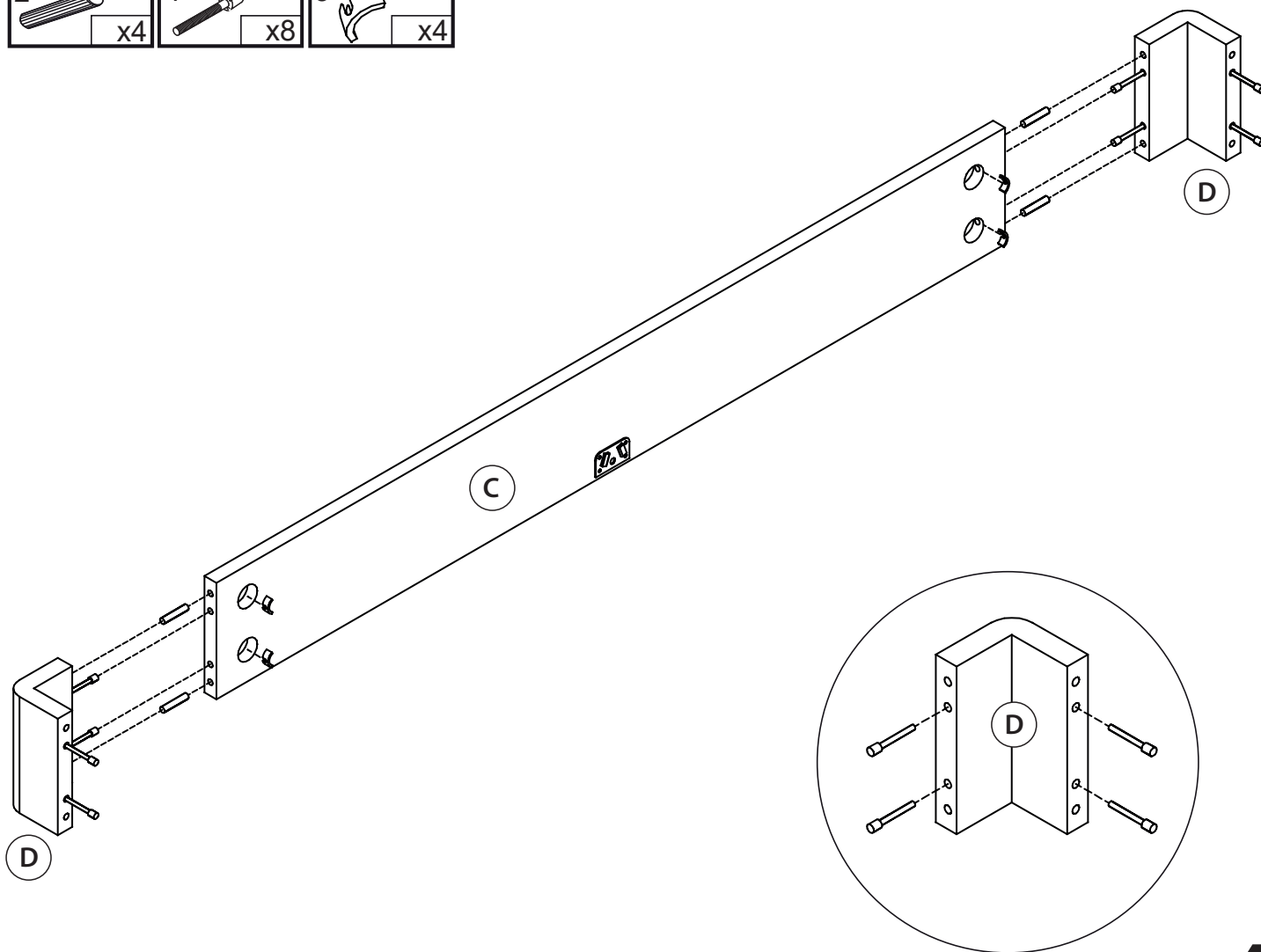
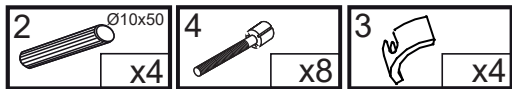

4

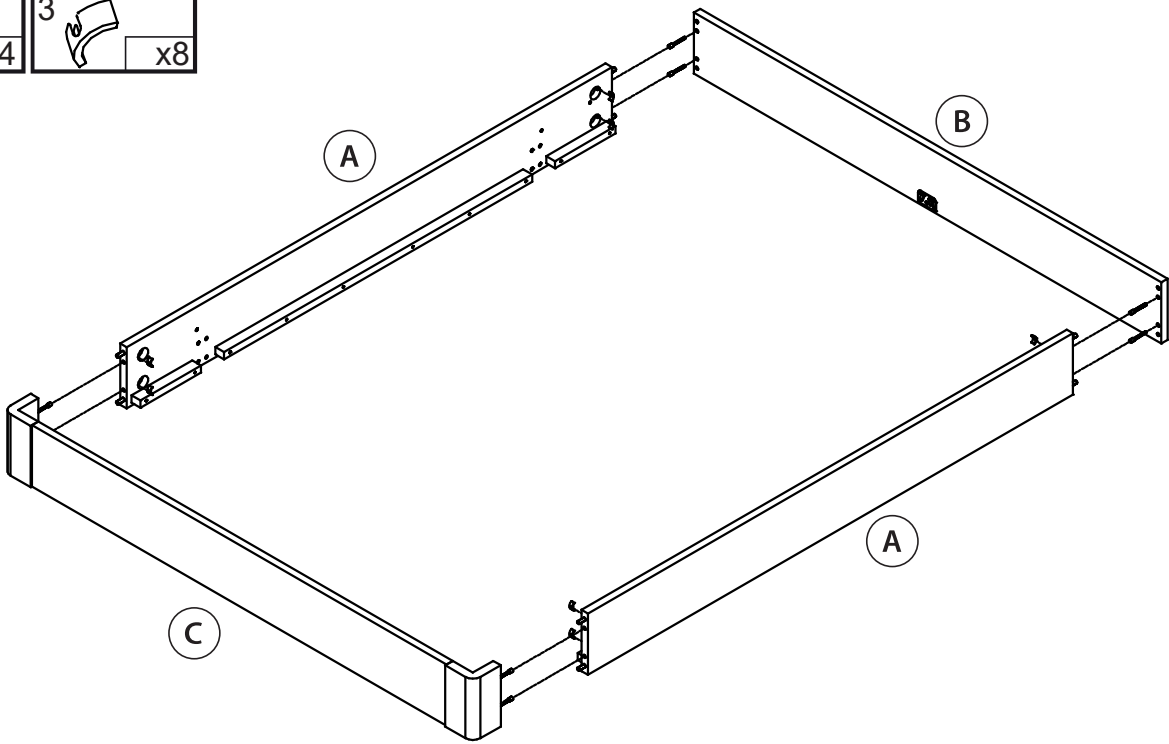
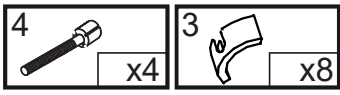

5

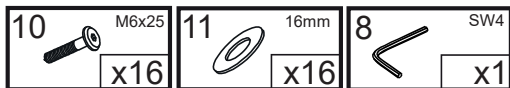
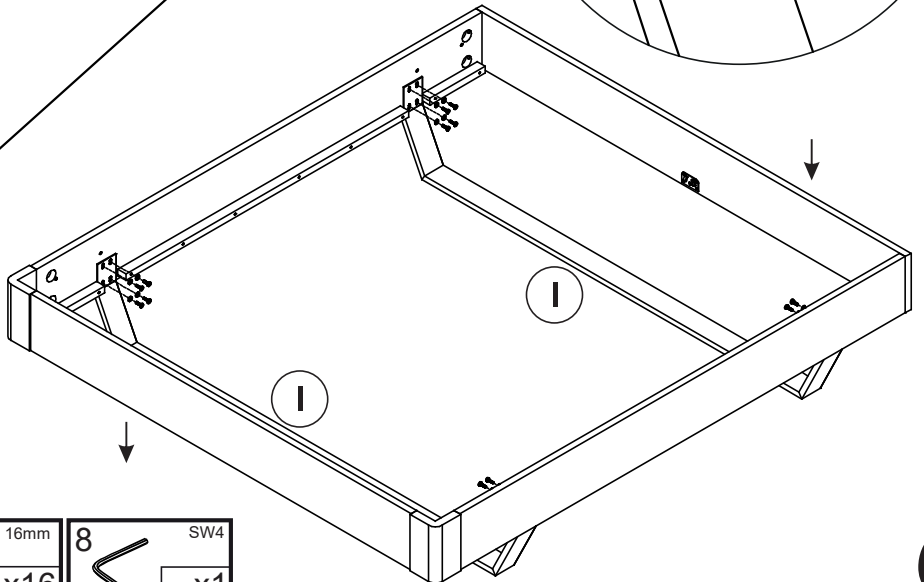
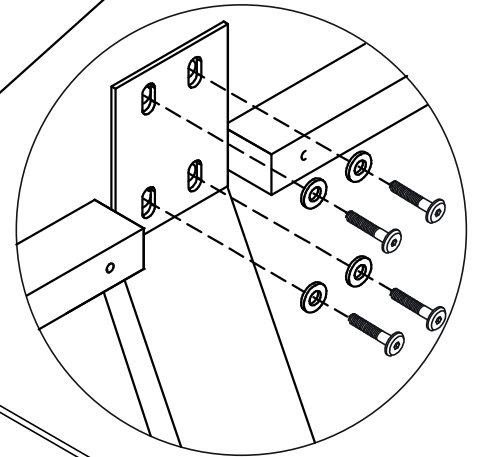
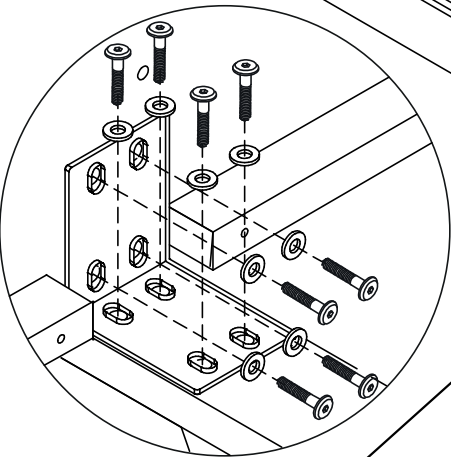
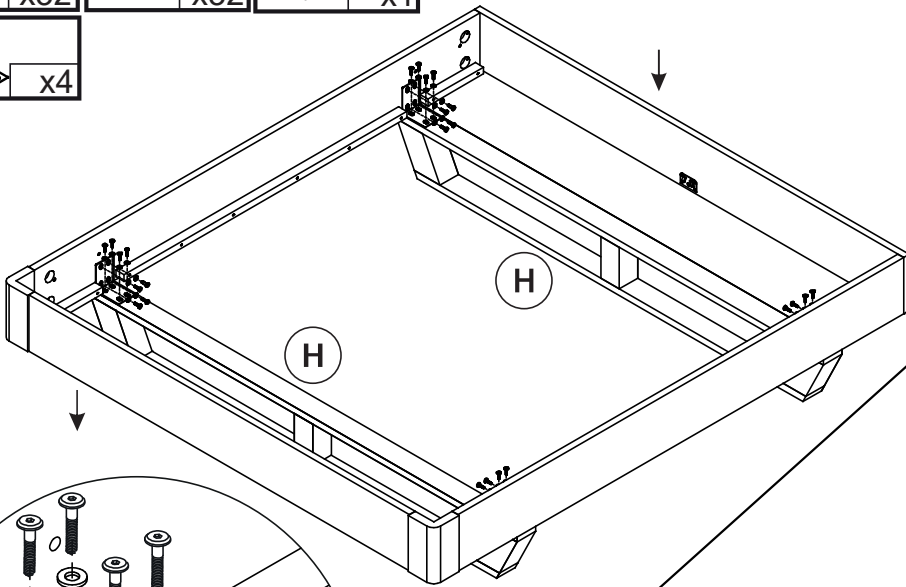
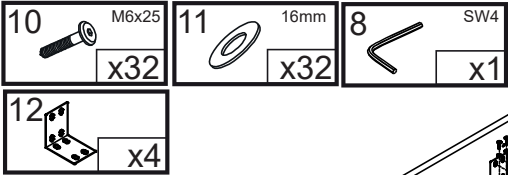

6

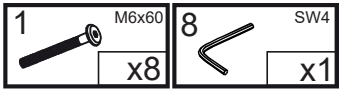
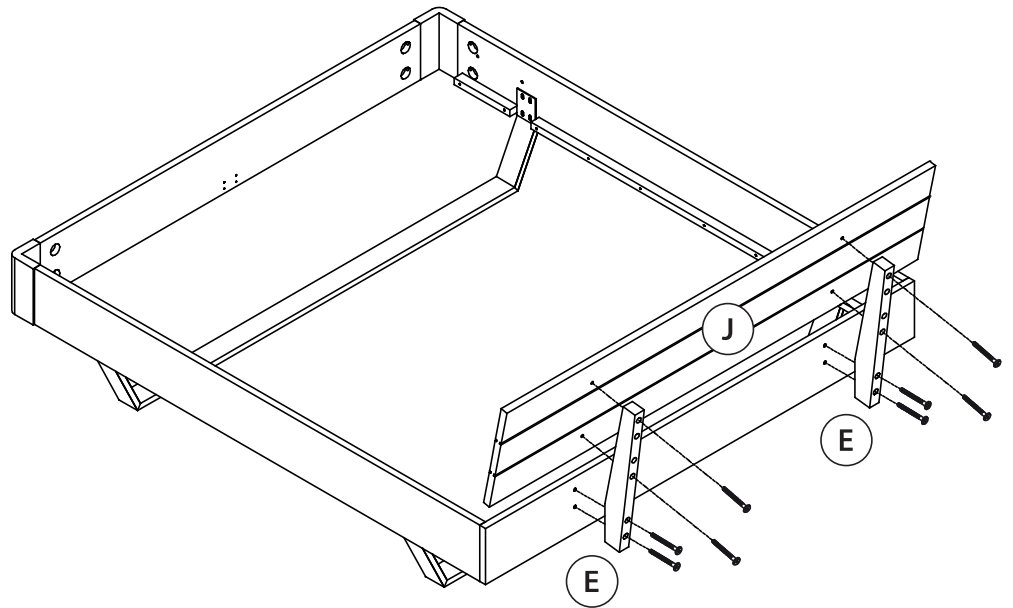
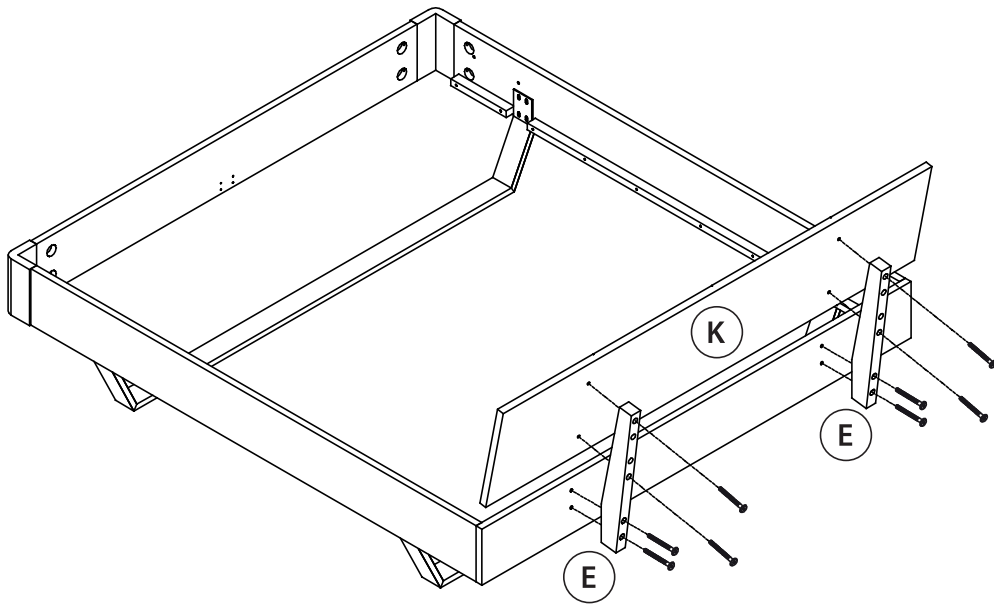

7

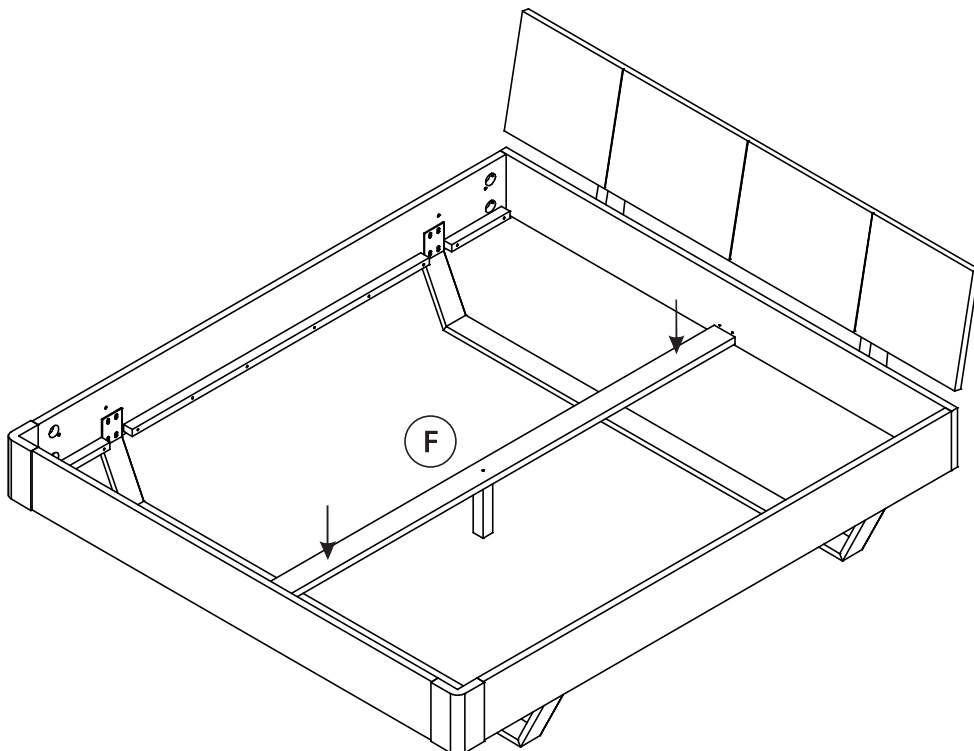

8