

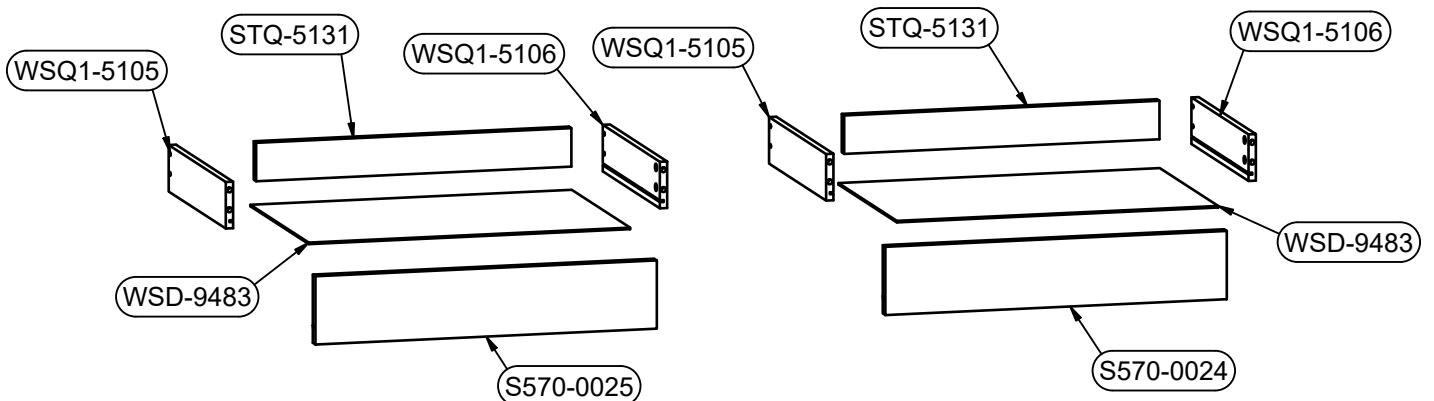

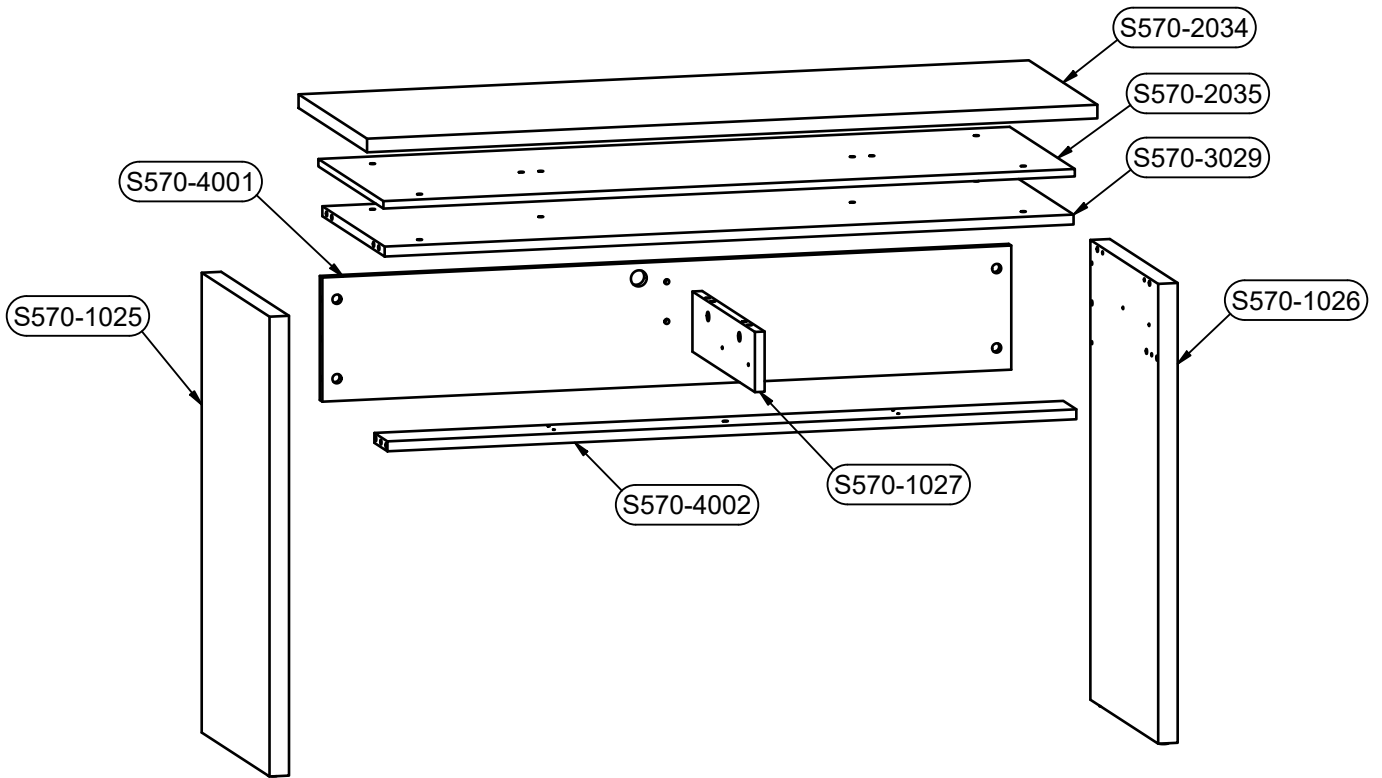

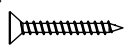

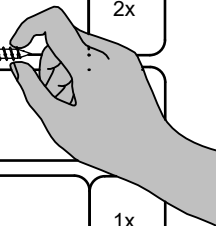





B1	B2	C1	C2	C3	C4	D
S570-0024	-1	561	110	16	1	2/2
S570-0025	-1	561	110	16	1	2/2
S570-1025	-1	741	416	32	1	1/2
S570-1026	-1	741	416	32	1	1/2
S570-1027	-2	383	97	16	1	1/2
S570-2034	-1	1200	420	22	1	1/2
S570-2035	-1	1136	399	12	1	2/2
S570-3029	-1	1132	382	16	1	2/2
S570-4001	-1	1132	200	16	1	2/2
S570-4002	-2	1132	80	16	1	2/2
STQ-5131	-	518	62	15	2	2/2
WSD-9483	-	528	358	2,5	2	2/2
WSQ1-5105	-	350	75	12	2	1/2
WSQ1-5106	-	350	75	12	2	1/2

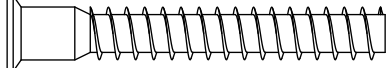
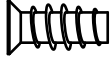

1:1

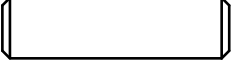
p16		2x		p16		2x	
p55				p55		1x	
f1		1x		f1		1x	

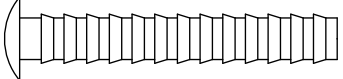
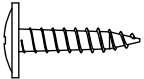
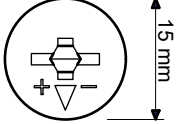
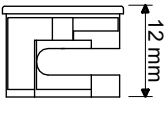
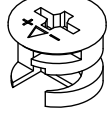

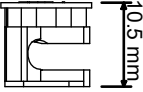
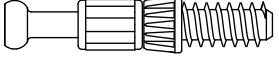
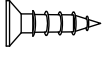
e1		3x	50mm	e3		8x	Ø6x13 mm
e40		6x	Ø7x45 mm	f1		12x	30mm
f13		2x	Ø8x20 mm	f25		8x	6.5x40 mm
p55		14x	2.9x16mm	r1	  	12x	15 mm 12 mm 15x12mm
r15	 	8x	12x10,5mm	r42		20x	
z28\4		6x	3x12mm				

~~1:1~~

k1

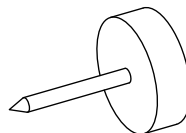

4x

n14\2

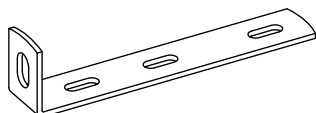

1x

s68

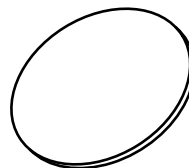

Ø20mm

2x

w167\L

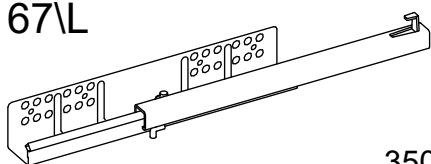

350mm

2x

w167\P

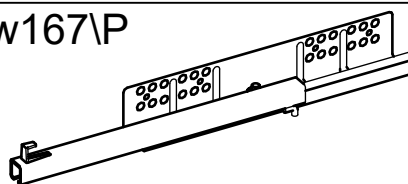

350mm

2x

z28\2

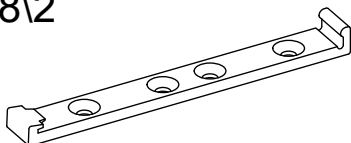

2x

z28\1

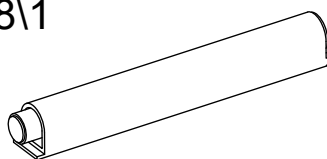

2x

z1



4mm

1x

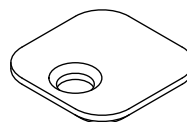

z28\3



2x

A**S570-TOL2S**

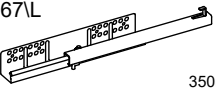
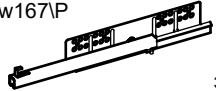
7 / 17

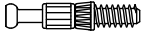

w167L  350mm	1x	w167P  350mm	1x	e3  Ø6x13 mm	4x	r42 	10x
---	----	---	----	---	----	--	-----

1 

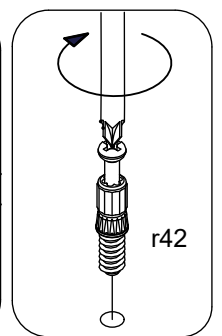
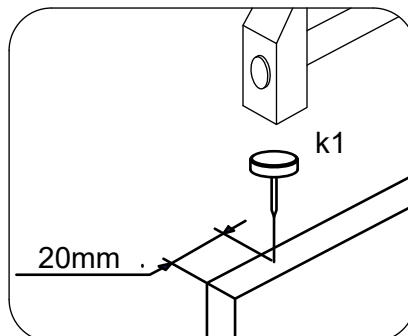
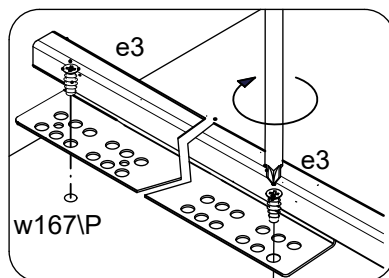
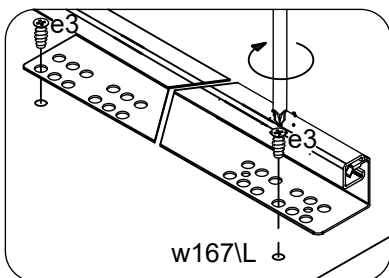
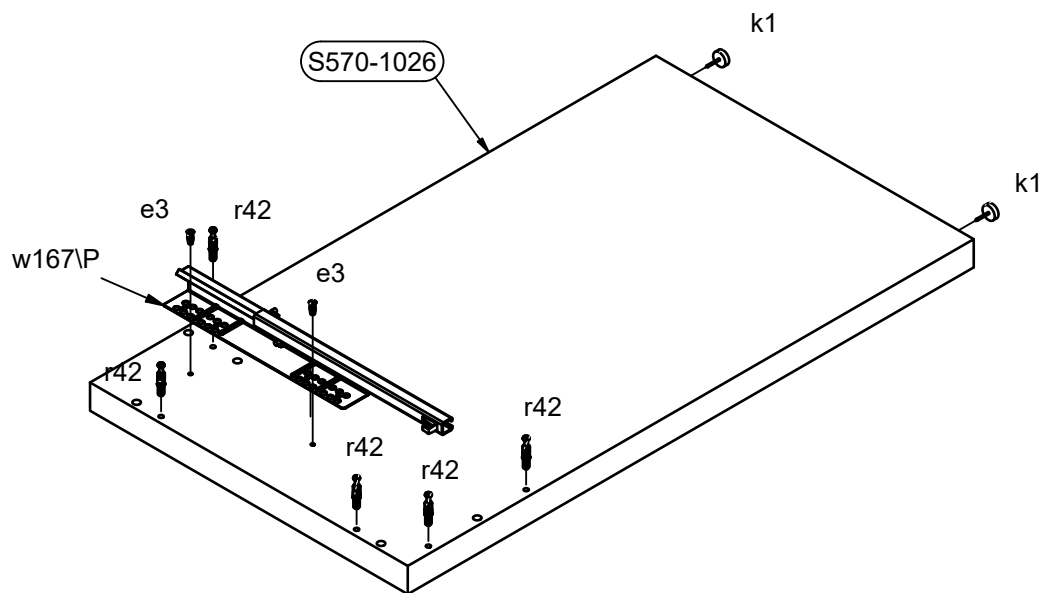
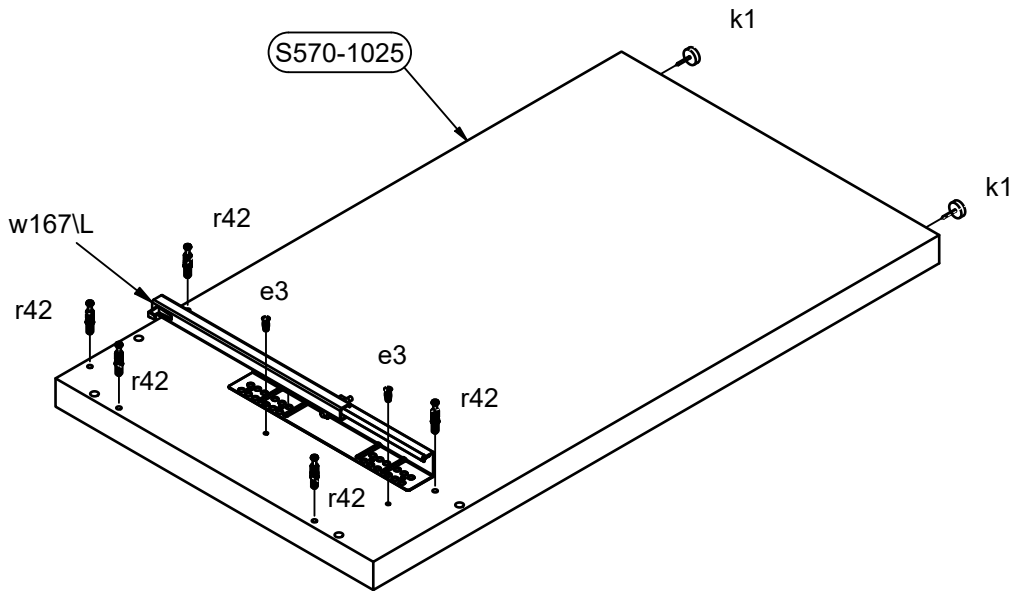
k1 	4x
---	----

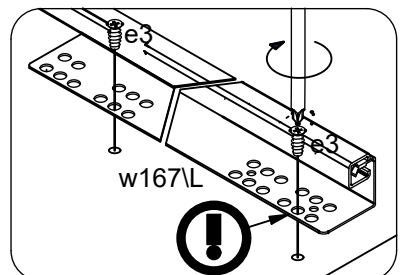
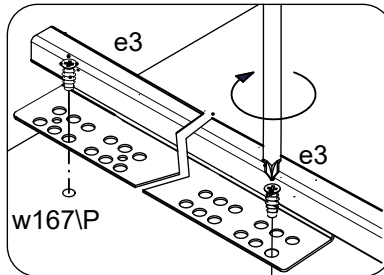
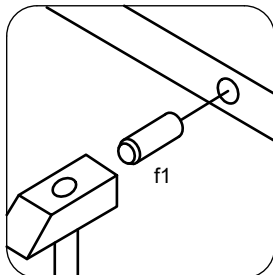
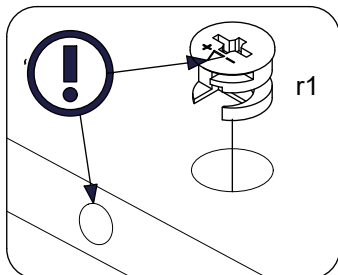
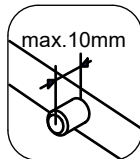
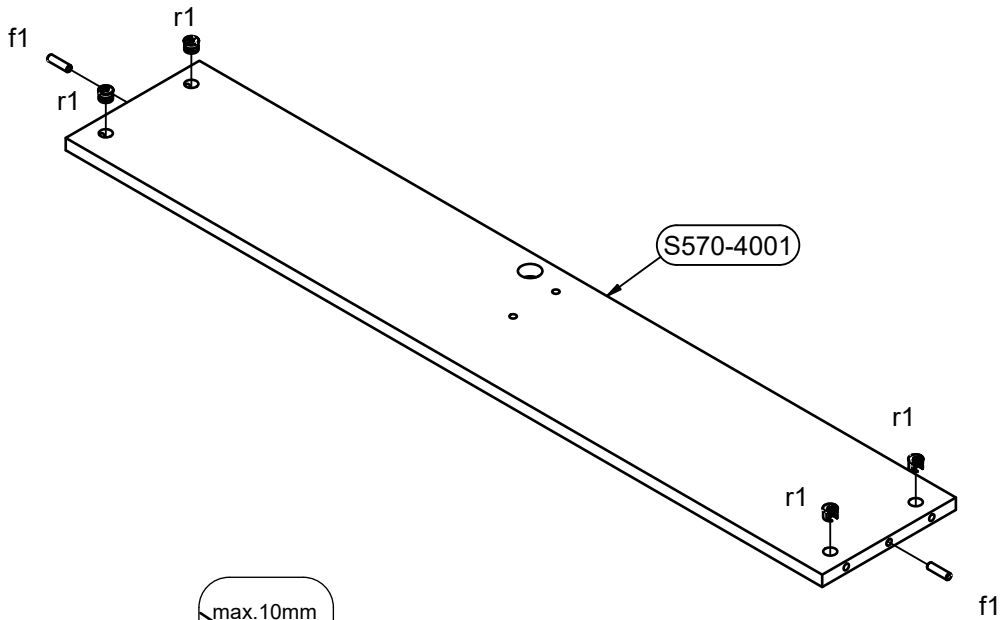
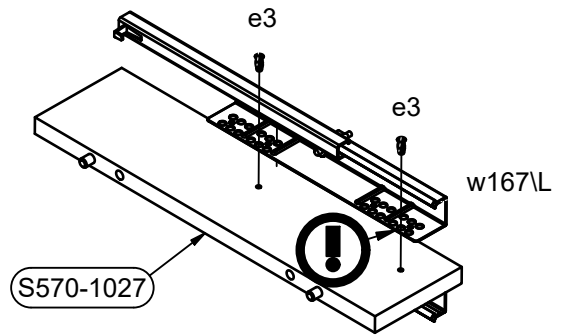
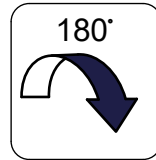
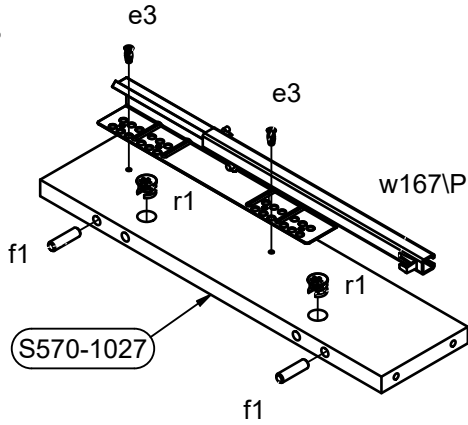
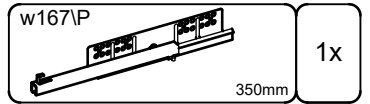
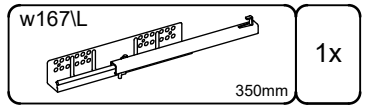
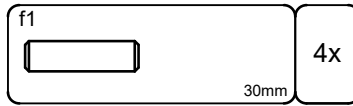
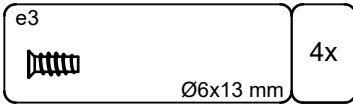
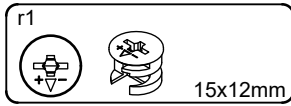

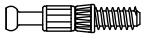

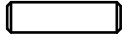



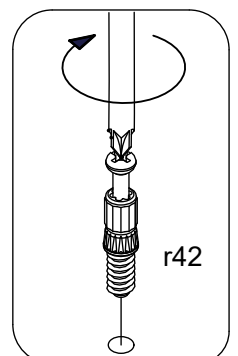
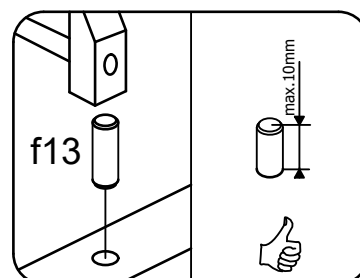
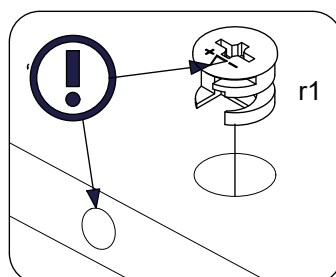
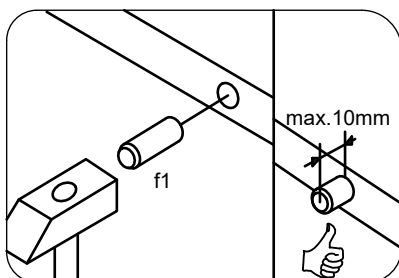
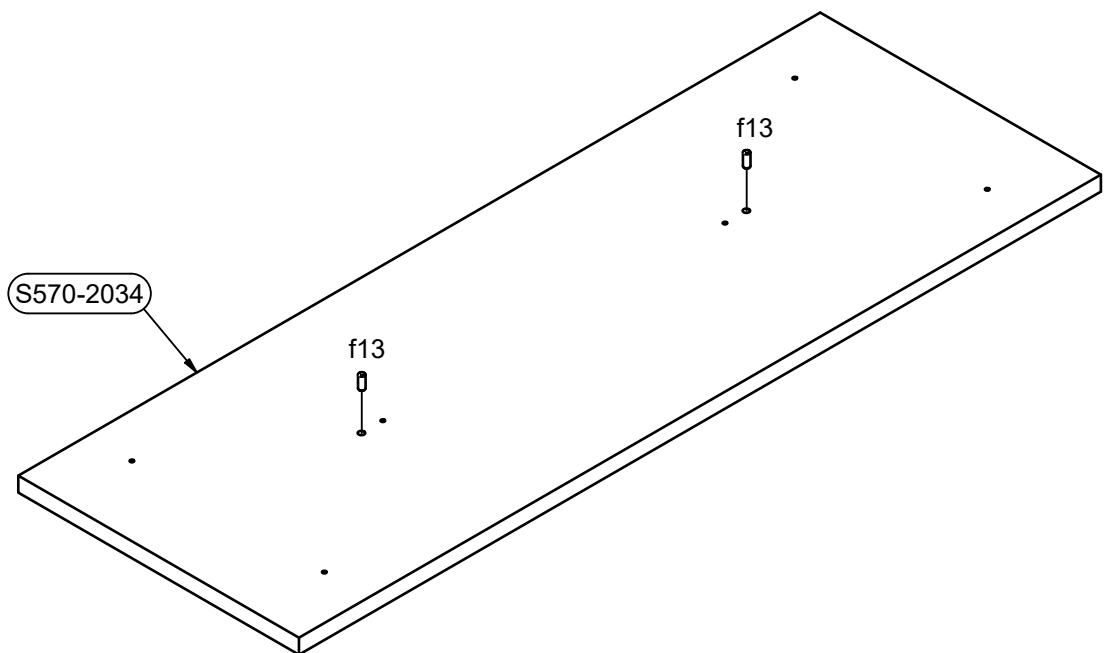
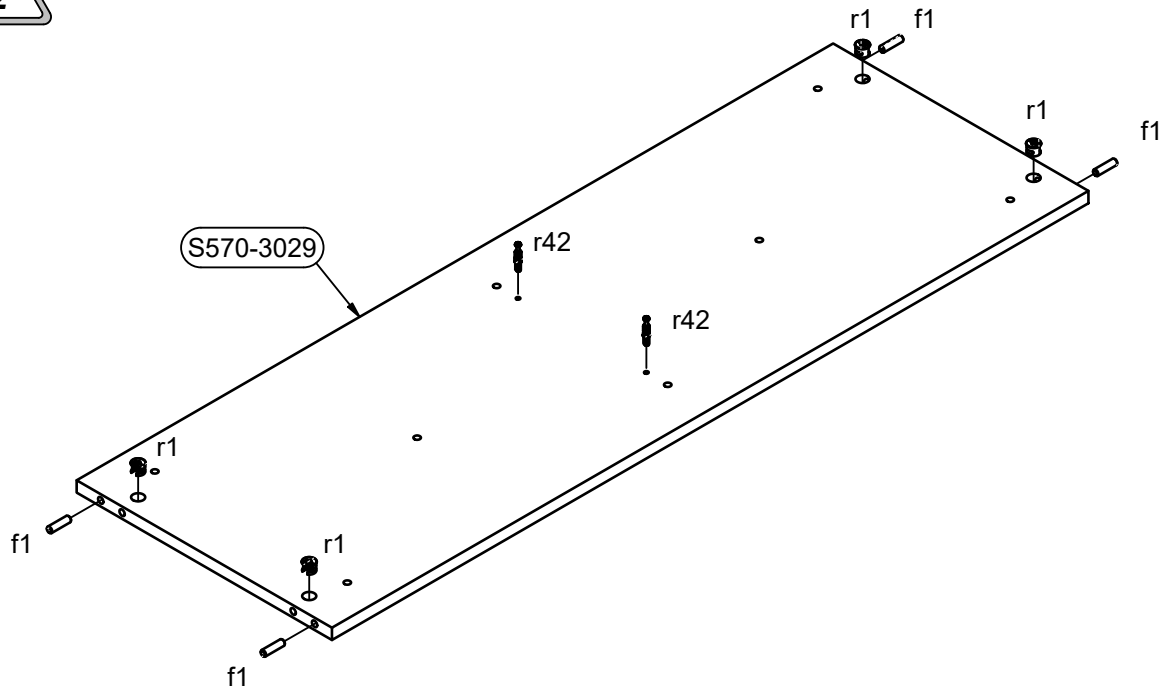

f13  Ø8x20 mm	2x	r42 	2x	r1   15x12mm	4x	f1  30mm	4x
--	----	--	----	--	----	---	----

3 

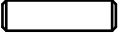

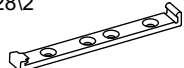
A**S570-TOL2S**

10 / 17

f1  30mm	4x	r1   15x12mm	2x	z28\2 	2x	z28\1 	2x
4 						z28\4  3x12mm	4x

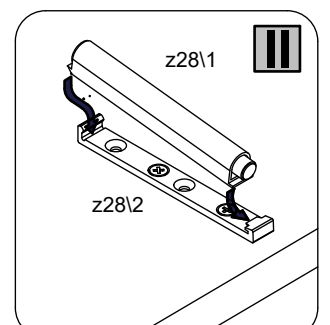
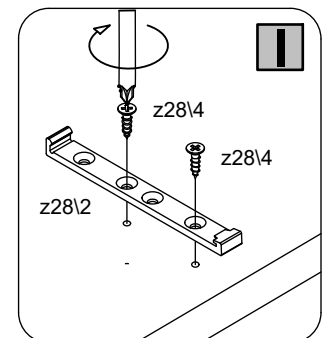
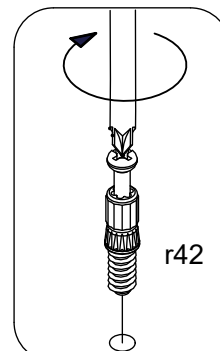
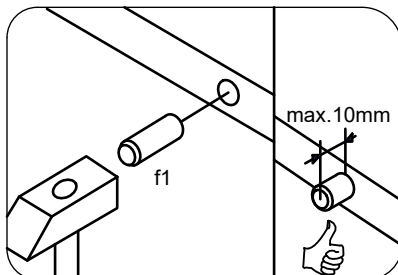
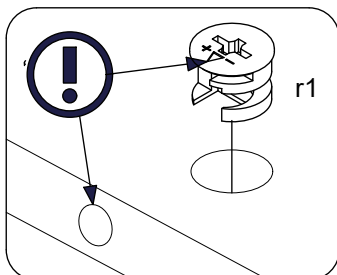
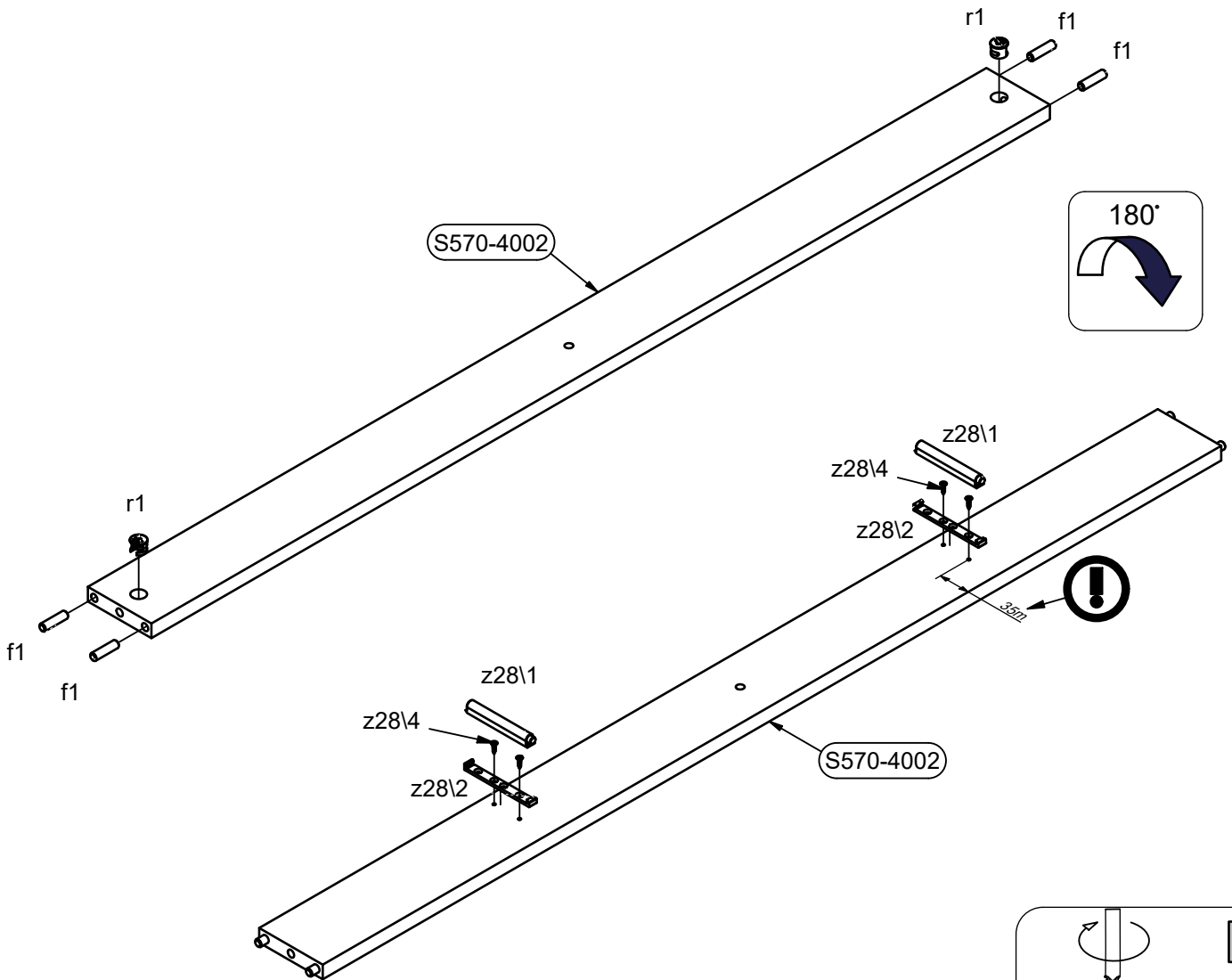

5

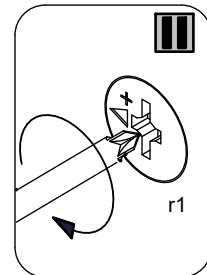
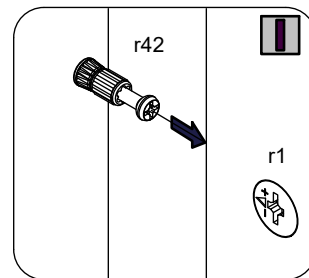
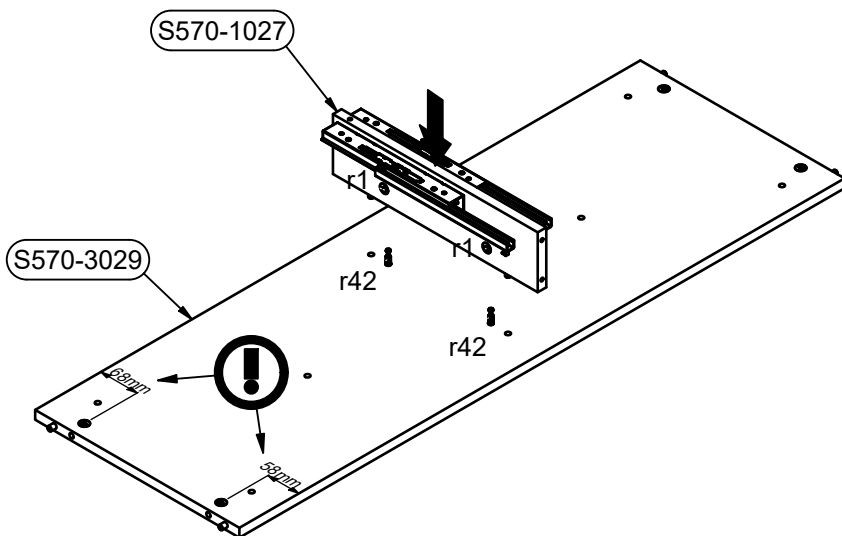

6

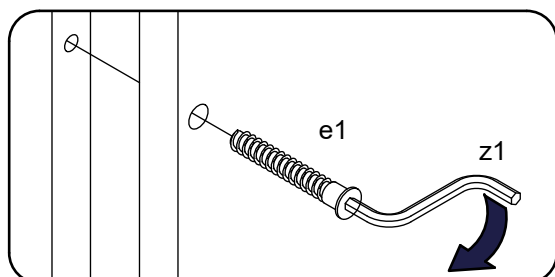
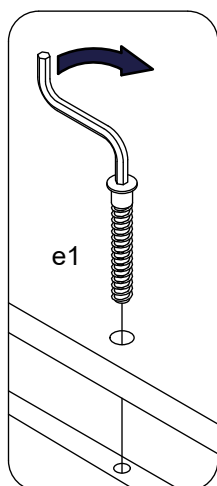
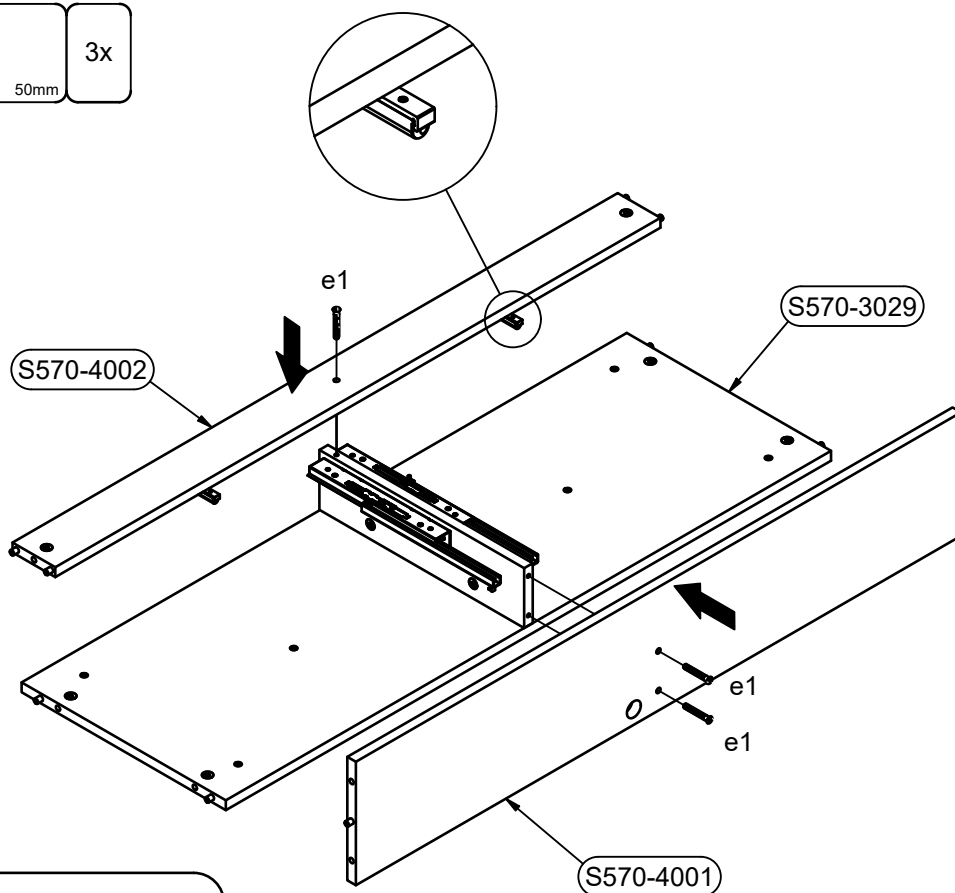
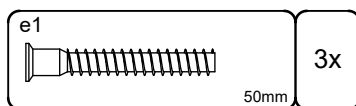

7

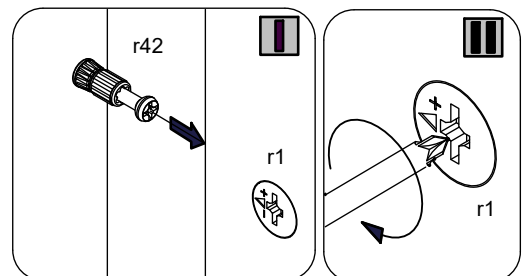
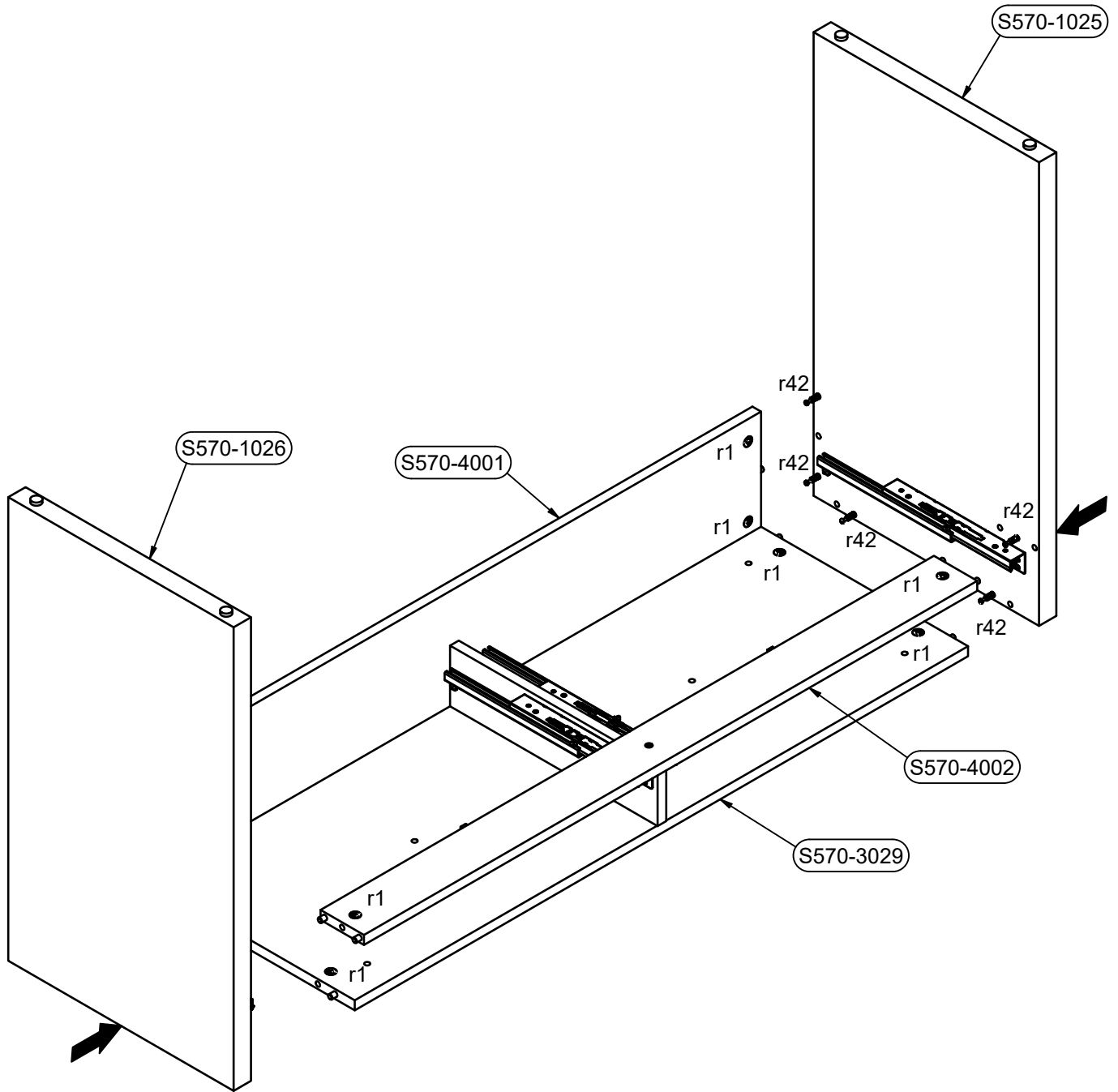



8

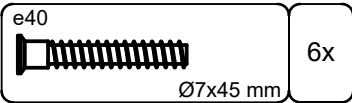
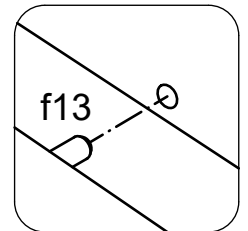
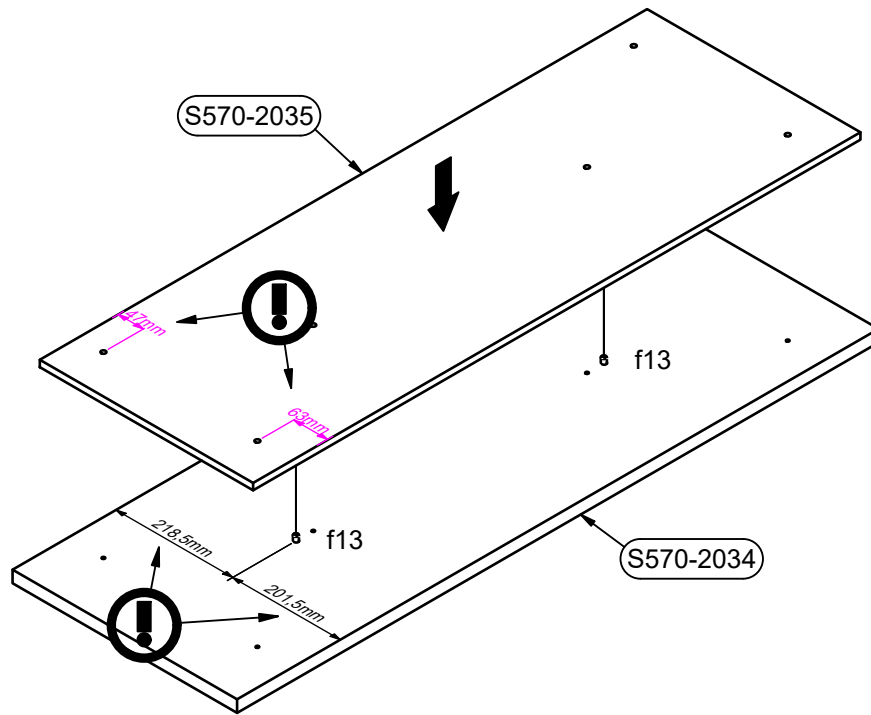

9

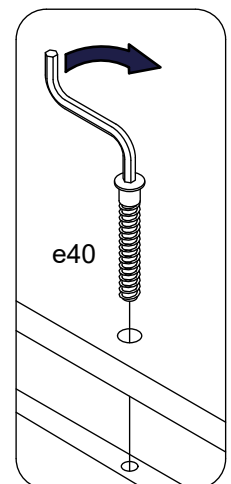
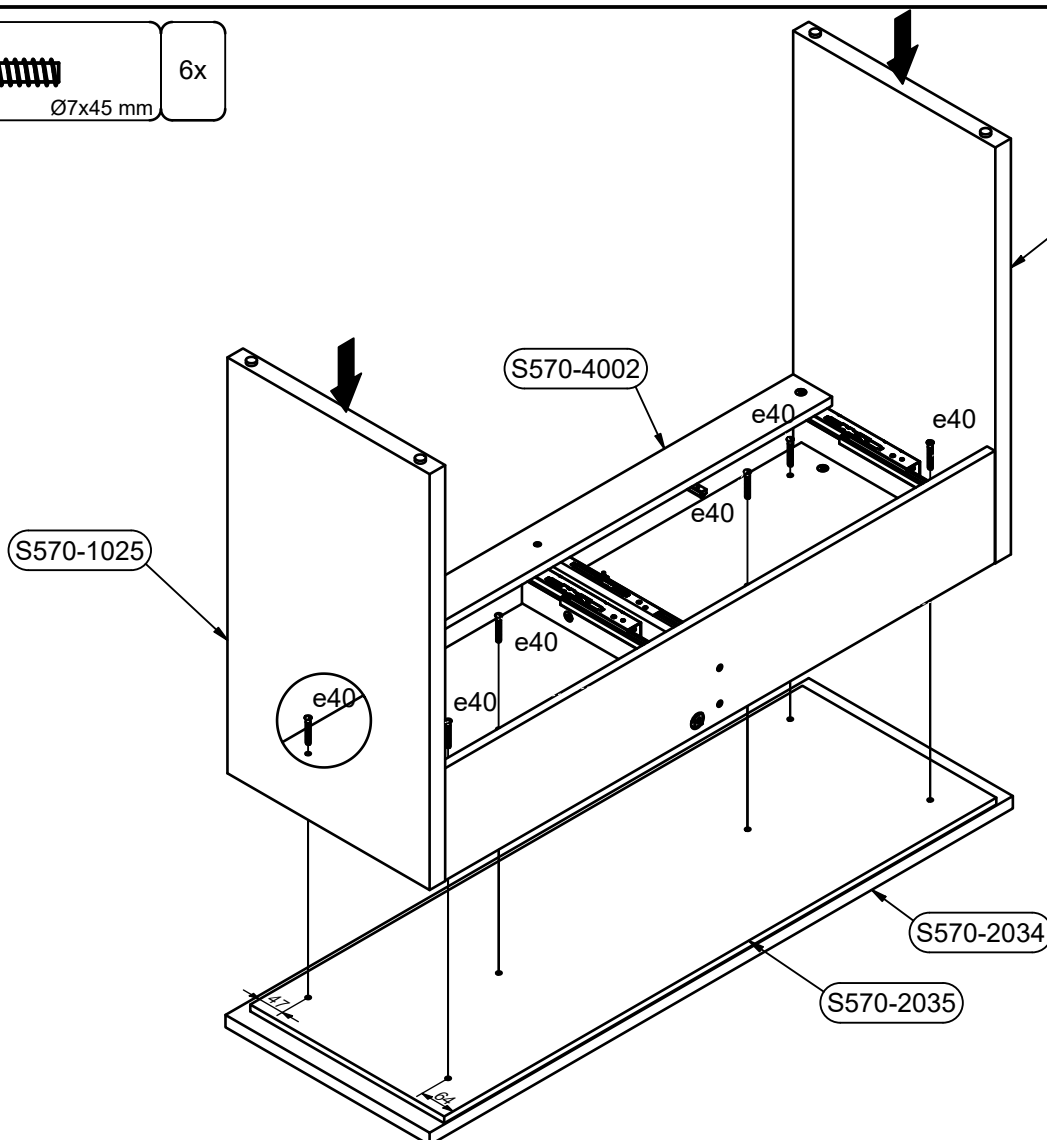

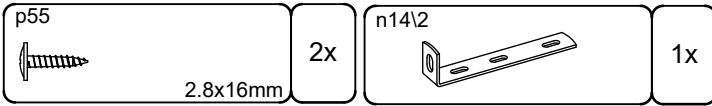
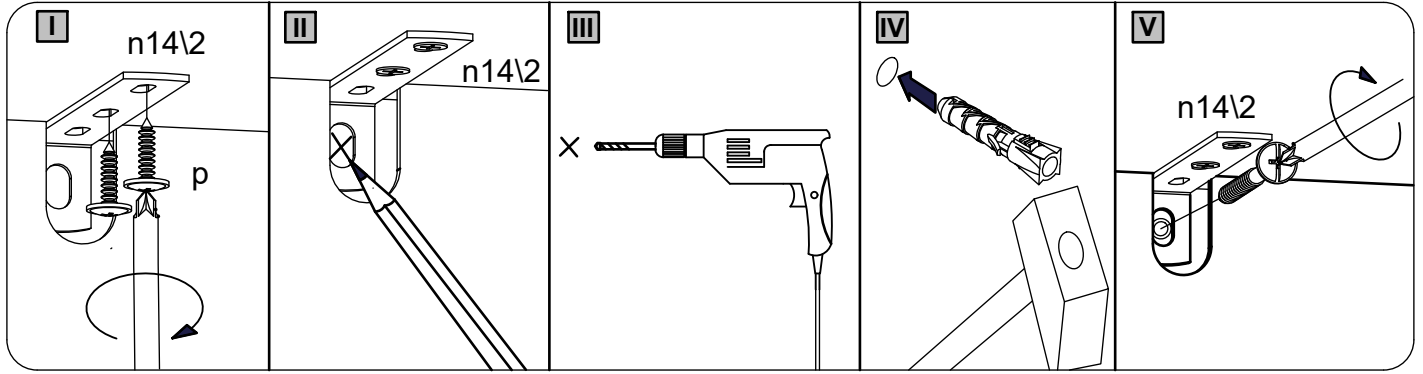



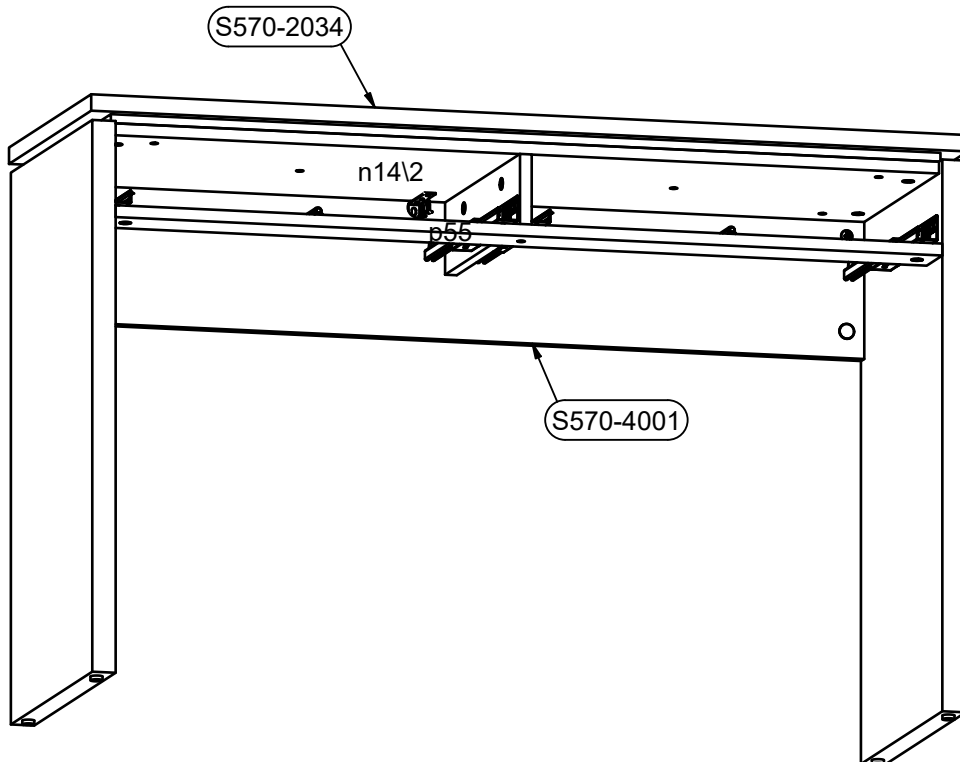
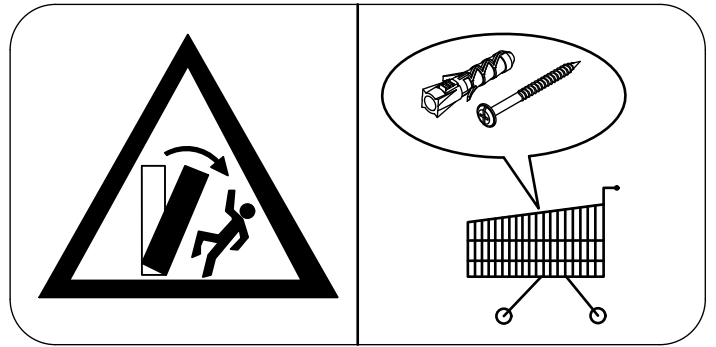



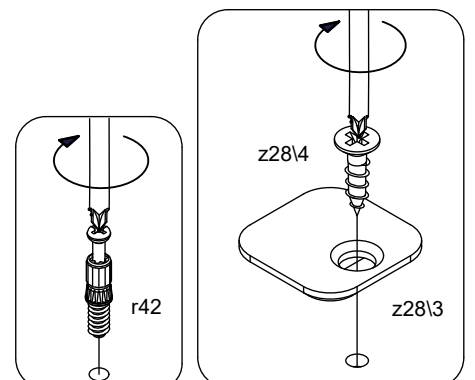
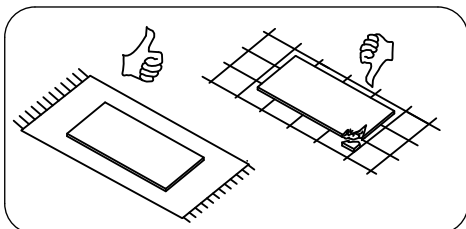
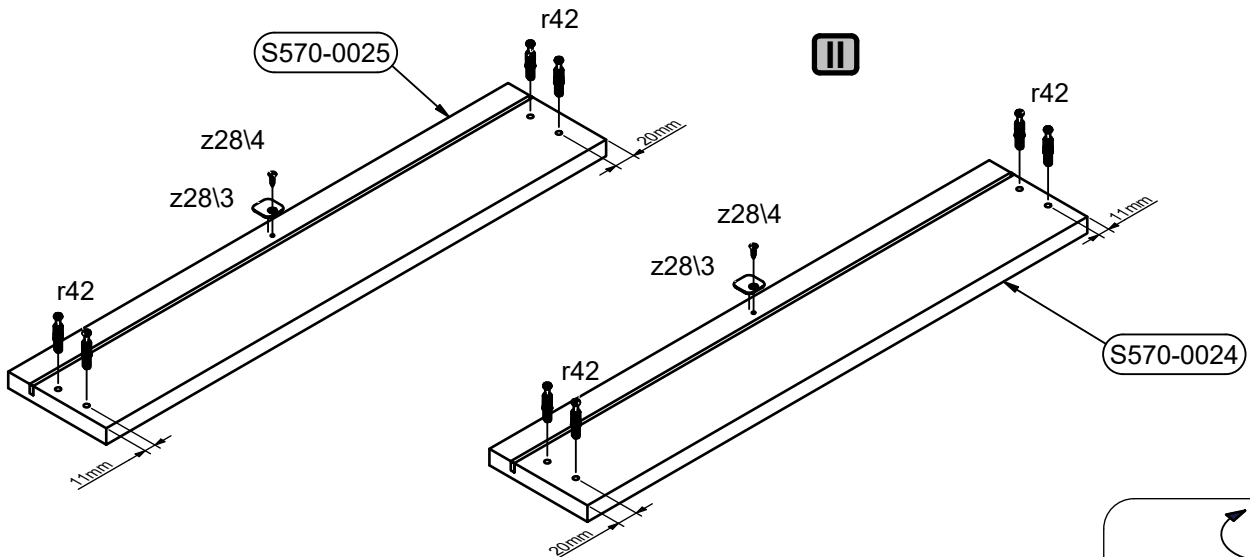
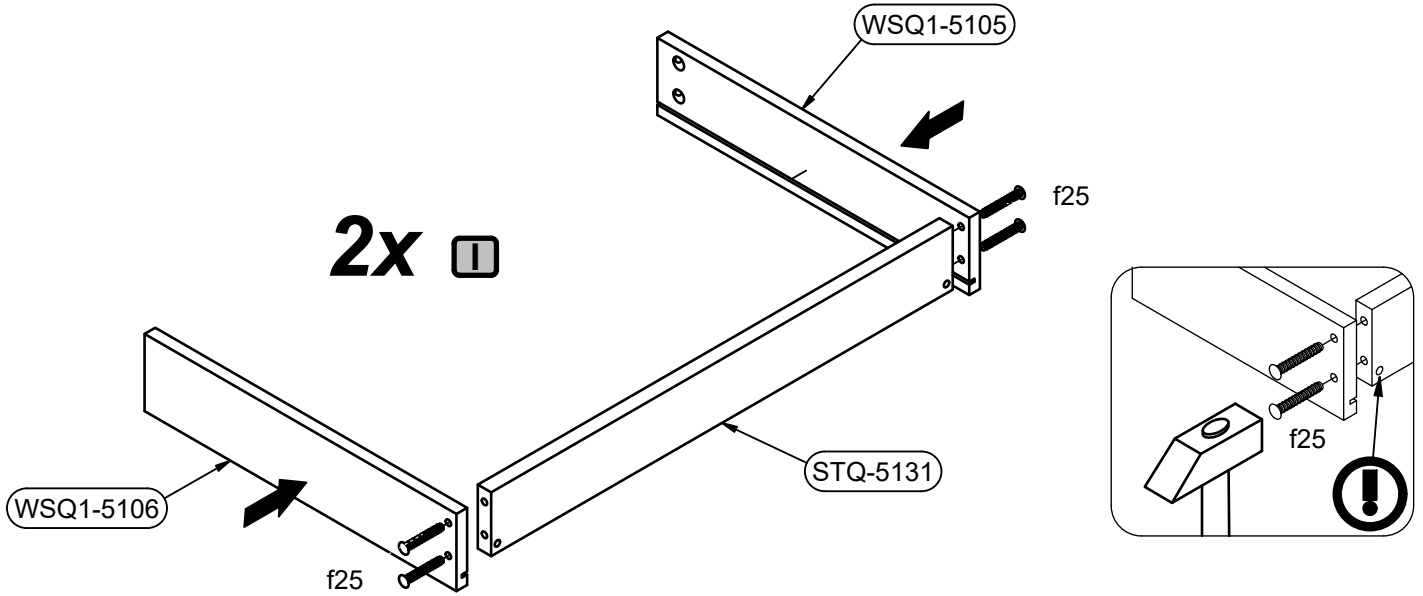

10



z28\4 3x12mm 2x	z28\3 2x	r42 8x	f25 6.5x40 mm 8x
-----------------------	-------------	-----------	------------------------

11  



r15 		12x10,5mm 	8x 	p55 	2.8x16mm 	10x 
--	---	---	---	--	---	--

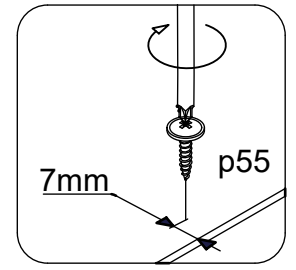
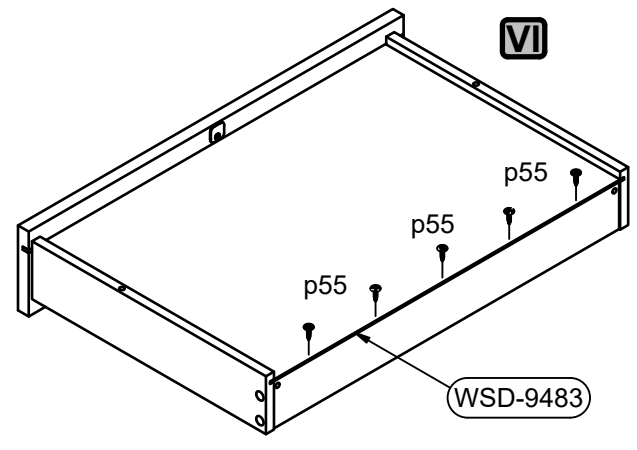
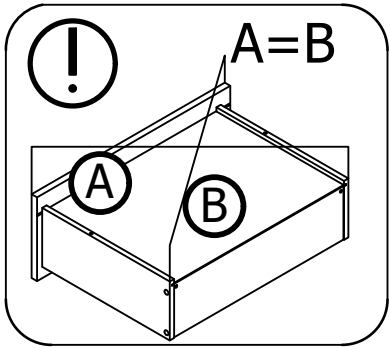
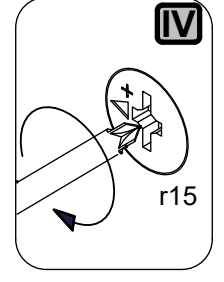
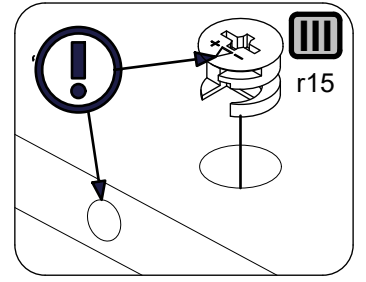
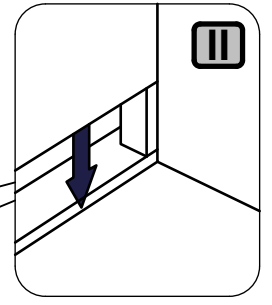
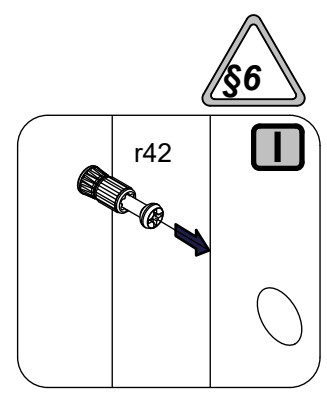
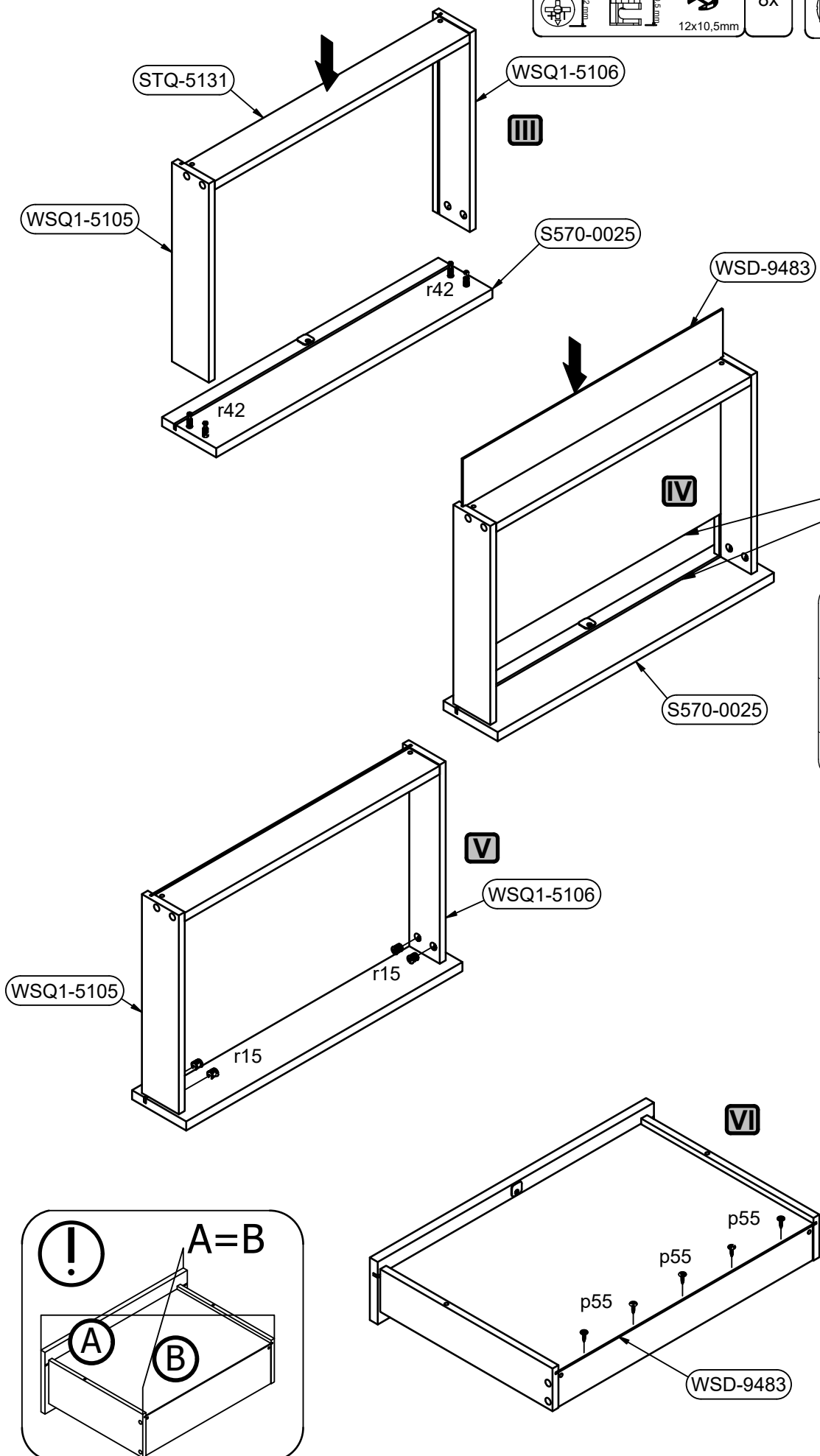

12

