

Gebrauchsanleitung PK-Nr. 3623

Instructions / Mode d'emploi / Gebruiksaanwijzing /
инструкция по использованию / 使用说明 / Használati utasítás

PAIDI Möbel GmbH
Hauptstraße 87
97840 Hafenlohr
Germany
info@paidi.de

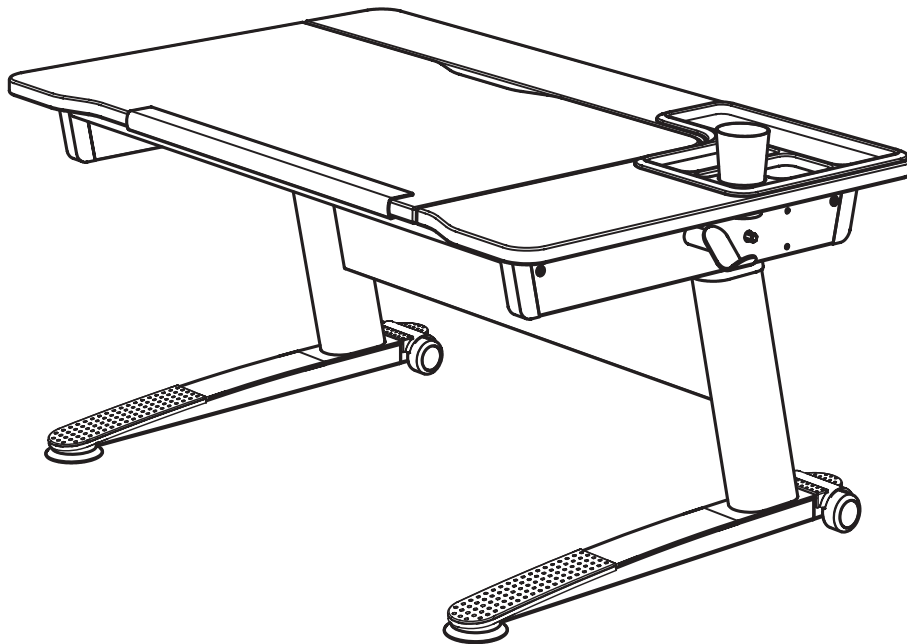

JARO
140 7341

Seite 1 von 24

PK-Nr. 3623 Stand 04/2025



www.blauer-engel.de/uz38

- emissionsarm
- Holz aus nachhaltiger Forstwirtschaft





Warnhinweis!

Warning! / Avertissement! / Waarschuwing! / Предупреждение! / 警告! / Figyelmeztetés



PAIDI Möbel GmbH
Hauptstraße 87
97840 Hafenlohr
Germany
info@paidi.de

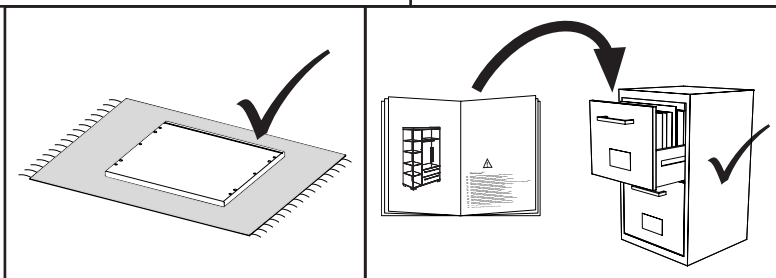

DE Zur Höhenverstellung des Schreibtisches muss die Schreibtischplatte schräg gestellt werden. Der Schreibtisch darf bei schräg gestellter Tischplatte nicht geschoben werden!

FR Pour régler la hauteur du bureau, il faut incliner le plateau du bureau. Ne pas pousser le bureau quand le plateau est incliné!

GB In order to adjust the height of the desk, the desktop has to be inclined. The desk must not be moved if the desktop is inclined!

NL Voor de hoogteverstelling van het bureau moet het schrijfblad schuin worden gesteld. Het bureau mag bij schuin gesteld schrijfblad niet worden geschoven!

ES Antes de ajustar la altura del escritorio colóquese su tablero en posición inclinada. Nunca debe desplazarse el escritorio cuando el tablero se encuentre en posición inclinada.

GR Για την ρύθμιση σε ύψος του γραφείου πρέπει να τοποθετηθεί πλάγιως η πλάκα γραφείου. Δεν επιτρέπεται η ώθηση του γραφείου με πλάγιως τοποθετημένη πλάκα!

IT Per la regolazione in altezza della scrivania, occorre inclinarne il piano di lavoro. La scrivania non deve essere spostata, con il piano di lavoro inclinato!

CZ Pro nastavení výšky psacího stolu se musí naklonit deska psacího stolu. Psací stůl se nesmí posouvat při nakloněné desce stolu!

SK Na nastavení výšky písacieho stola sa musí nakloniť doska písacieho stola. Písací stôl sa nesmie posúvať pri naklonenej doske stola!

SL Za prestavitev višine pisalne mize je ploščo pisalne mize potrebno prestaviti v poševen položaj. Pri poševno ležeči plošči pisalne mize ni dovoljen no potiskati!

PL W celu przestawienia wysokości biurka blat biurka ustawiony musi być pochyły. Biurko nie wolno przesuwać przy pochyłym ustawionym blacie!

BG За да се регулира височината на бюрото, плочата на бюрото трябва да бъде поставена в наклонено положение. Бюрото не бива да се мести, ако плочата се намира в наклонено положение.

HR Za podešavanje visine pisaćeg stola se ploča pisaćeg stola mora postaviti u kosi položaj. Pisaći stol se kod ukoso postavljene ploče stola ne smije gurati!

LT Rašomojo stalo aukštį galima keisti pakreipiant rašomojo stalo stalviršį įstrižai. Draudžiama stumti rašomąjį stalą, kai stalviršius pakreiptas įstrižai!

RU При регулировке высоты стола столешница должна находиться в наклонном положении. Стол нельзя двигать, если столешница находится в наклонном положении.

CN 要调整桌子的高度，必须先调节桌面至倾斜的状态。写字台在桌面是倾斜的状态下不应移动!

HU Ha az íróasztal magasságát állítani kell, akkor az asztallapot meg kell dönteni. Az íróasztalt nem szabad tolni, ha az asztallap meg van dőlve!

DE Schraubenverbindungen von Zeit zu Zeit auf ihre Festigkeit prüfen, gegebenenfalls nachziehen, da die Stabilität der Konstruktion sonst nicht gegeben ist.

FR Vérifier les connexions à vis de temps en temps, resserrer celles-ci le cas échéant, car, sinon, la stabilité de la construction ne serait pas assurée.

GB Check the tightness of the screw connections from time to time and tighten if necessary, as otherwise the stability of the construction is not assured.

NL Schroefverbindingen moeten van tijd tot tijd op hun stevigheid worden gecontroleerd en eventueel worden vastgedraaid, aangezien de stabiliteit van de constructie anders niet verzekerd is.

ES Compruebe de vez en cuando la firmeza de las uniones atornilladas y reapriete los tornillos si fuera necesario, pues de lo contrario quedaría afectada la estabilidad de la estructura.

GR Πού και πού ελέγχετε τη σταθερότητα των κοχλιωτών συνδέσεων κι εφ' όσον είναι ανάγκη, τις σφίγγετε ξανά, επειδή διαφορετικά δεν είναι η ευστάθεια της κατασκευής δεδομένη.

IT Controllare di tanto in tanto la tenuta delle connessioni a viti, all'occorrenza provvedere a serrarle di nuovo, poiché altrimenti non è garantita la stabilità della struttura.

CZ Čas od času zkontrolujte pevnost šroubových spojů, případně je dotáhněte, jinak nebude konstrukce stabilní.

SL Vijačne zveze od časa do časa preveriti glede na trdnost, po potrebi priviti, saj sicer stabilnost konstrukcije ne bo zagotovljena.

PL Połączony śrubami sprawdzaj od czasu do czasu pod kątem ich trwałości, ewentualnie dokręcaj, gdyż inaczej konstrukcja nie jest stabilna.

BG Контролирайте от време на време дали болтовите съединения са добре завинтени, тъй като в противен случай не може да се гарантира стабилността на конструкцията.

HR Spojeve vijaka s vremena na vrijeme provjeriti u svezi čvrstoće, po potrebi stegnuti, jer inače nije zajamčena stabilnost konstrukcije.

LT Kartais patikrinkite varžtų jungčių stiprumą, prireikus suvėžkite juos stipriau, nes priešingu atveju konstrukcija nebus stabili.

RU Перепроверяйте время от времени болтовые соединения. Они должны быть плотно затянуты. Это гарантирует стабильность конструкции.

CN 请经常的检查连接处的螺丝，如有发现松动请及时锁紧，否则将无法保障其稳定性。

HU Időről ellenőrizze a csavarokékes szorosságát, adott esetben a csavarokat után kell húzni, ellenkező esetben a szerkezet stabilitása nem adott.

DE Pflegehinweis: Zum Reinigen der Oberflächen ein leicht-feuchtes Tuch oder ein handelsübliches Möbelpflegemittel verwenden.

FR Indication sur l'entretien : pour nettoyer les surfaces, utiliser un chiffon légèrement humide ou un nettoyeur pour meubles en vente dans le commerce

GB Caring for the... : In order to clean the surfaces please use a slightly damp cloth or commercially available furniture care product.

NL Verzorgingsanwijzing: Voor het reinigen van de oppervlakken een licht vochtig doek of een gebruikelijk meubelschoonmaakmiddel gebruiken.

ES Recomendaciones de cuidado: Para limpiar las superficies del mueble debe usar un trapo humedecido o un producto de limpieza de muebles comercial.

GR Οδηγίες περιποίησης: Για το καθάρισμα των επιφανειών να χρησιμοποιείτε ένα ελαφρά υγραμένο πανάκι ή λούστρο επίπλων.

IT Indicazione per pulizia e cura: Per la pulizia delle superfici utilizzate un panno leggermente umido o un normale prodotto per la cura dei mobili.

CZ Pokyny k čištění: Na čištění povrchu použijte pouze navlhčený kousek látky nebo běžný prostředek na ošetřování nábytku.

SL Navodilo za nego: Za čiščenje površina uporabljajte malo vlažno cunjno ali trgovsko običajno sredstvo za nego pohištva.

PL Wskazówka pielęgnacyjna: do czyszczenia powierzchni stosować lekko wilgotną ściereczkę lub zwykły środek do pielęgnacji mebli.

BG Указание за поддържане: Използвайте леко навлажнена кърпа или обикновен препарат за поддържане на мебели, за да почистите повърхностите.

HR Upute za njegu: Za čišćenje površina upotrijebiti jednu lako navlaženu krpu i trgovačko uobičajeno sredstvo za njegu namještaja.

LT Rekomendacija priežiūrai: Paviršius valykite drėgna pašluoste arba parduotuvėse įsigytomis baldų priežiūros priemonėmis.

RU Рекомендации по уходу: для очистки поверхностей используйте слегка влажную тряпку или обычное средство по уходу за мебелью.

CN 保养说明: 清洁表面只需用稍微潮湿的布或普通的家具清洁剂即可。

HU Ápolás: A felületek tisztításához enyhén nedves ruhát vagy a kereskedelemben kapható bútorpólopó terméket használjon.

DE: Lesen Sie bitte diese Sicherheitshinweise sorgfältig durch, bevor Sie das Produkt benutzen.

- Die Gasdruckfeder steht unter hohem Druck. Die Gasdruckfeder darf nicht geöffnet und nicht erhitzt werden.
- Defekte oder beschädigte Gasdruckfedern dürfen nicht genutzt werden und sollten durch einen Fachkundigen ausgetauscht werden.
- Gasdruckfeder, Kolbenstange und Dichtungsbaugruppe vor Verschmutzung und mechanischen Beschädigungen schützen.
- Im eingebauten Zustand dürfen keine seitlichen Belastungen auf die Gasdruckfeder aufgebracht werden.

GB: Please read these safety instructions carefully before using the product.

- The gas spring is under high pressure. The gas spring must not be opened and must not be heated.
- Defective or damaged gas springs must not be used and should be replaced by a specialist.
- Protect the gas spring, piston rod and seal assembly from contamination and mechanical damage.
- When installed, no lateral loads may be applied to the gas spring.

FR: Veuillez lire soigneusement les indications de sécurité avant d'utiliser le produit.

- L'amortisseur à gaz est mis sous une pression élevée. L'amortisseur à gaz ne doit pas être ouvert ni chauffé.
- Ne pas utiliser les amortisseurs à gaz défectueux ou endommagés et les faire remplacer par une personne compétente.
- Protéger l'amortisseur à gaz, la tige du piston et l'assemblage d'étanchéité contre l'encrassement et les dommages mécaniques.
- Ne pas soumettre l'amortisseur à gaz à des charges latérales lorsqu'il est monté.

NL: Lees deze veiligheidsinstructies zorgvuldig door voordat u het product gebruikt.

- De gasveer staat onder hoge druk. De gasveer mag niet worden geopend en niet worden verwarmd.
- Defecte of beschadigde gasveren mogen niet worden gebruikt en moeten door een specialist worden vervangen.
- Bescherm de gasveer, zuigerstang en afdichtingsmodule tegen vuil en mechanische beschadigingen.
- In ingebouwde toestand mogen op de gasveer geen zijdelingse belastingen worden uitgeoefend.

RU: Перед использованием продукта внимательно прочтите эти указания по безопасности.

- Газовая пружина находится под высоким давлением. Запрещено вскрывать или нагревать газовую пружину.
- Эксплуатация неисправных или поврежденных газовых пружин запрещена. Они подлежат замене квалифицированным персоналом.
- Не допускайте загрязнения и механических повреждений газовой пружины, поршневого штока и уплотнительного узла.
- В установленном состоянии на газовую пружину не должны воздействовать боковые нагрузки.

CN: 在使用产品之前，请仔细阅读本安全说明。

- 气压弹簧处于高压状态。气压弹簧不可被打开或加热。
- 有缺陷或损坏的气压弹簧不可使用，应由专业人员更换。
- 保护气压弹簧、活塞杆和密封组件不受灰尘和机械损伤。
- 装入状态下，不可对气压弹簧施加任何横向负荷。

HU: Kérjük, olvassák el figyelmesen az alábbi biztonsági tudnivalókat, mielőtt a terméket használni kezdik.

- A gázrugó nagy nyomás alatt áll. A gázrugót nem szabad kinyitni vagy felmelegíteni.
- Meghibásodott vagy sérült gázrugókat nem szabad használni, ezeket egy szakemberrel kell kicseréltetni.
- A gázrugót, a dugattyúrudat és a tömítéskészletet óvni kell az elszennyeződéstől és a mechanikus sérülésektől.
- Beépített állapotban a gázrugókat nem szabad oldalirányú terhelésnek kitenni.

Code-Nr. 681 8270
BLAU / ROSA

Code-Nr. 681 8272 BLAU
Code-Nr. 681 8273 ROSA

Code-Nr. 671 7798

Code-Nr. 671 7499

1x
14

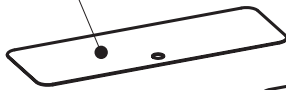

Code-Nr. 681 8271
BLAU / ROSA

Code-Nr. 681 8089

1x
9



1x
10

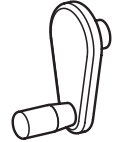

1x
11

1x
12

1x
13

Code-Nr. 681 1009

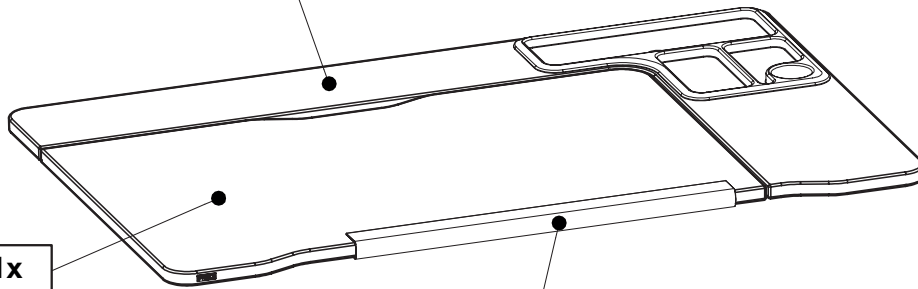

1x
12

1x
11

1x
13

Code-Nr. 681 1009

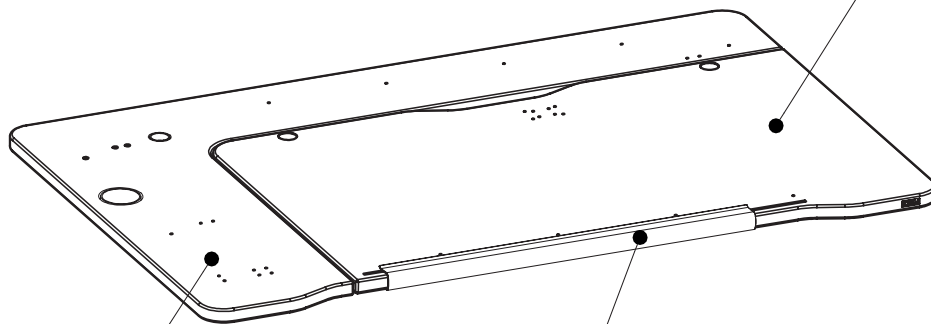

Code-Nr. 671 7858

2x
2

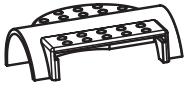

Code-Nr. 671 7854

2x
3

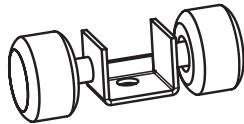

Code-Nr. 671 7852

1x
5

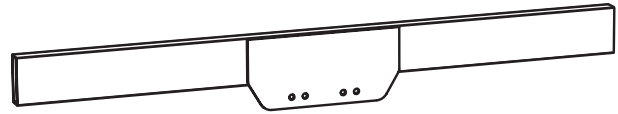

Code-Nr. 671 7855

1x
6

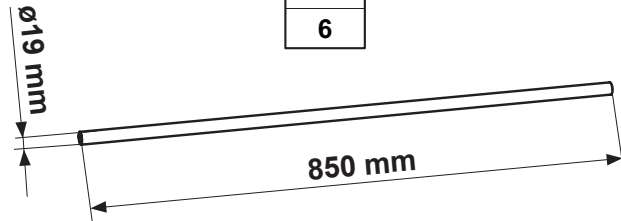

Code-Nr. 671 7851

1x
4

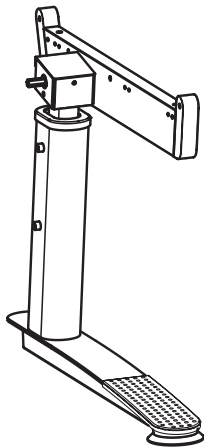

Code-Nr. 671 7853

2x
8

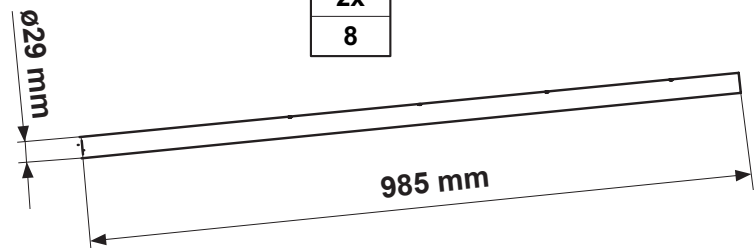

Code-Nr. 671 7850

1x
1

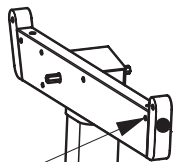

Code-Nr. 378 5051 WEISS

1x
7

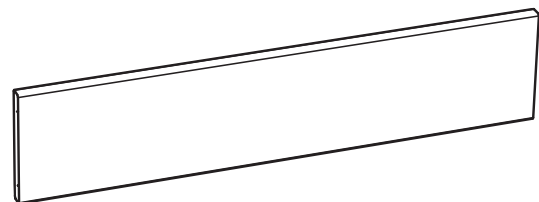

Code-Nr. 671 7867

Code-Nr. 671 7862

Code-Nr. 671 7859

Code-Nr. 671 7860

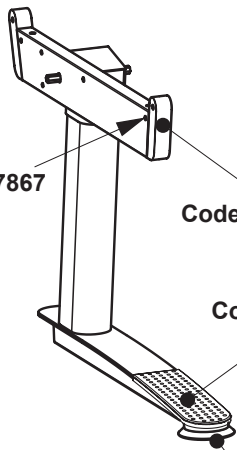

Bei defekten Beschlägen bitte
Code-Nr. angeben.

Beschläge

Fittings / Raccords / Hulpstukken /
Фурнитура / 配件 / Vasalatok

PAIDI Möbel GmbH
Hauptstraße 87
97840 Hafenlohr
Germany
info@paidi.de



1:1
DIN A4





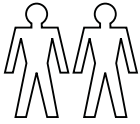



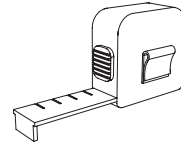





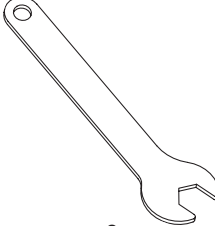
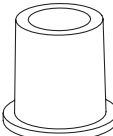
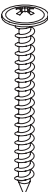
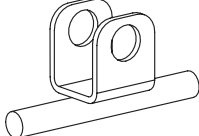
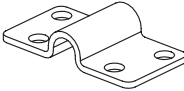

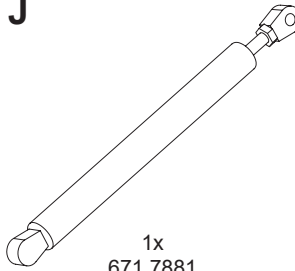
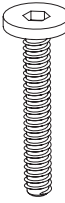
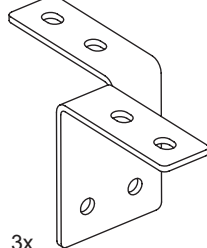
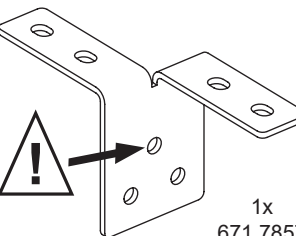
ca. 2,0h

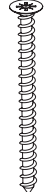
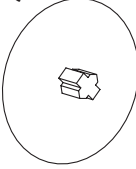
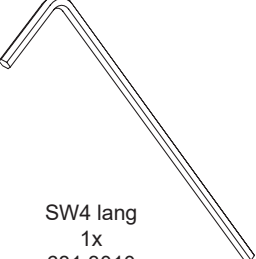

PZ 2

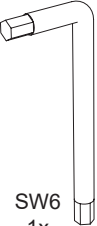





<p>A</p>  <p>M8 x 15 2x 671 7865</p>	<p>B</p>  <p>4x 671 7863</p>	<p>C</p>  <p>1x 671 7875</p>	<p>D</p>  <p>2x 671 7877</p>	 <p>2x 681 7765</p>	<p>E1</p>  <p>2x 681 5550</p>	<p>E2</p>  <p>4,0 x 40 2x 681 4911</p>	<p>F</p>  <p>1x 671 7879</p>
<p>G</p>  <p>2x 671 7880</p>	<p>H</p>  <p>4,0 x 20 14x 681 4917</p>	<p>I</p>  <p>1x 671 7876</p>	<p>J</p>  <p>1x 671 7881</p>	<p>K</p>  <p>M6 x 40 4x 671 7866</p>	<p>L</p>  <p>3x 671 7856</p>		
<p>L1</p>  <p>1x 671 7857</p>	<p>M</p>  <p>M5 x 20 7x 671 7868</p>	<p>N</p>  <p>M6 x 50 5x 671 7864</p>	<p>O</p>  <p>M5 x 10 2x 681 3930</p>	<p>P</p>  <p>4,0 x 45 8x 681 4893</p>	<p>Q</p>  <p>WEISS 4x 681 7485</p>		
 <p>SW4 lang 1x 681 3010</p>	 <p>SW5 1x 681 3014</p>	 <p>SW4 1x 681 3011</p>	 <p>SW6 1x 681 3015</p>	 <p>SW2,5 1x 671 3005</p>			

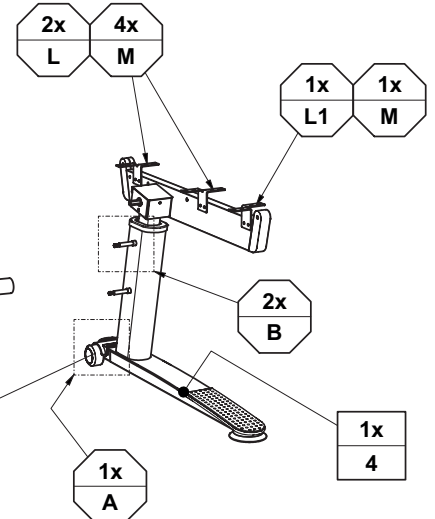
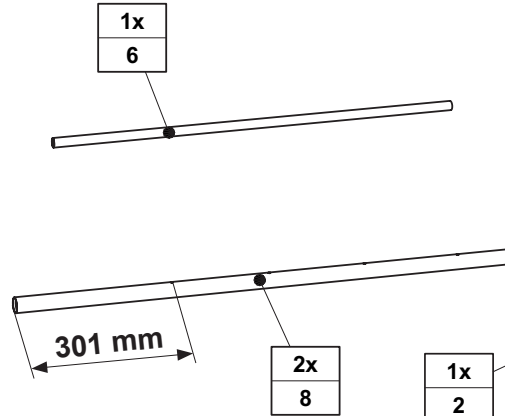
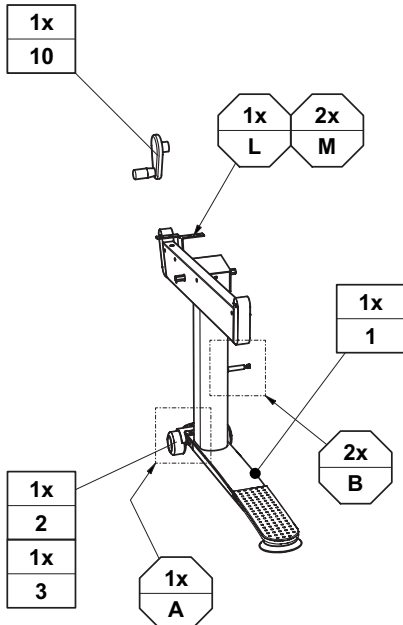
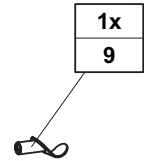
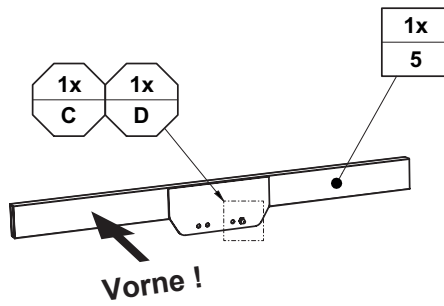
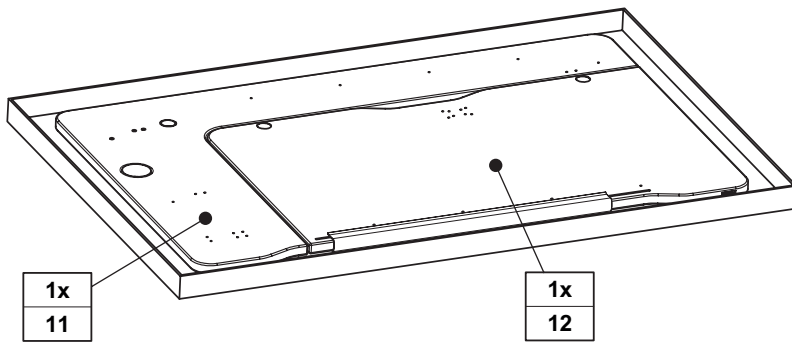

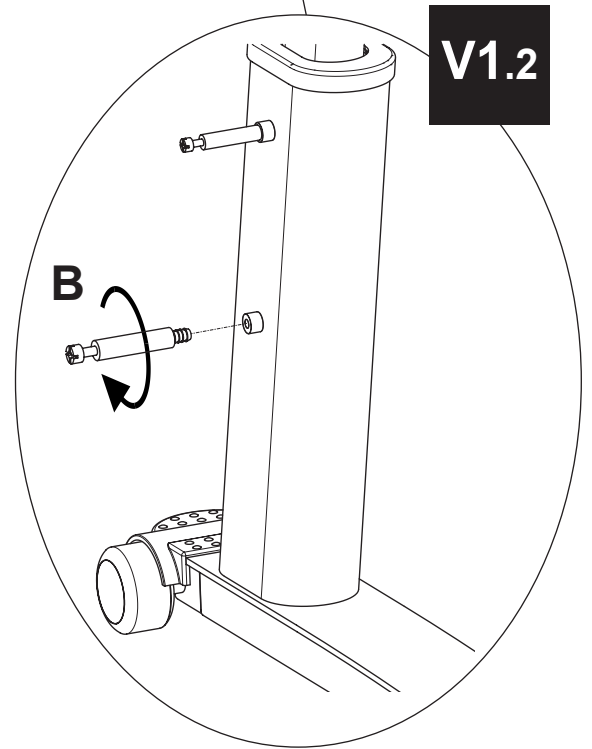
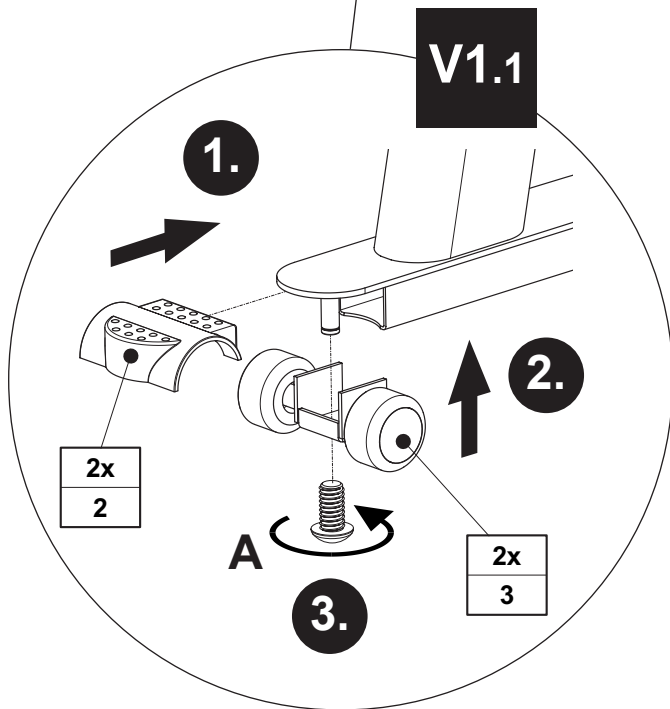
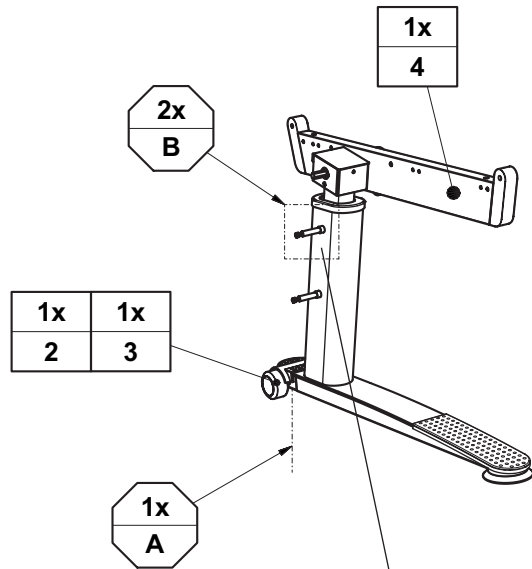
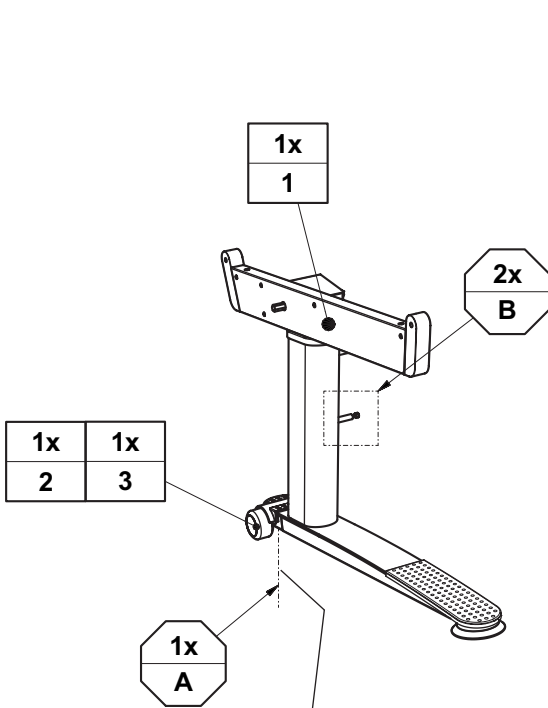

Schreibtisch im Karton liegend montieren
The desk is laid flat in the box for assembly.
Monter le bureau à plat dans le carton.
Bureau liggend in het karton monteren.
Монтируйте стол в коробке в лежачем
положении.
把桌子平放躺在箱子里组装起来。
Az íróasztal összeszerelése a dobozban
fekvő helyzetben történik.





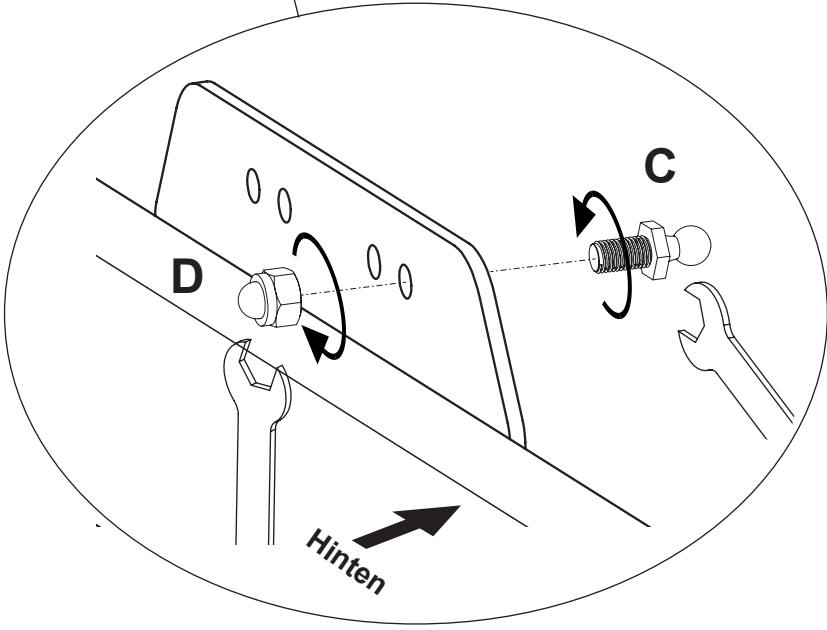
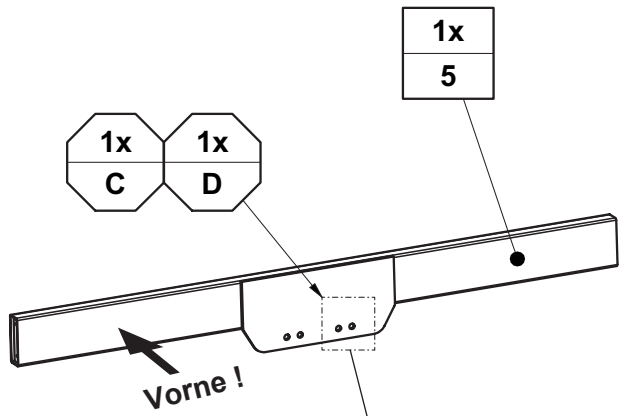

	A 	B 
SW4 1x 681 3011	M8 x 15 2x 671 7865	4x 671 7863

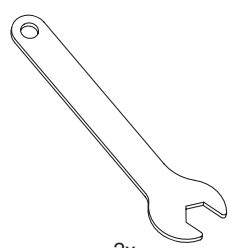

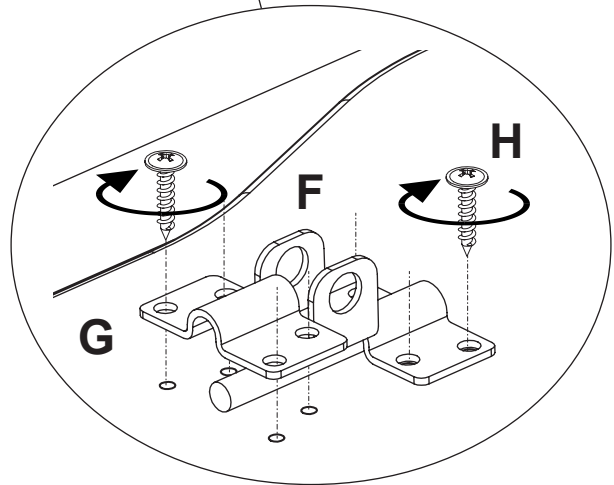
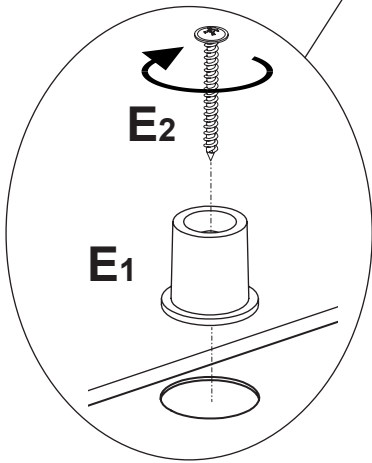
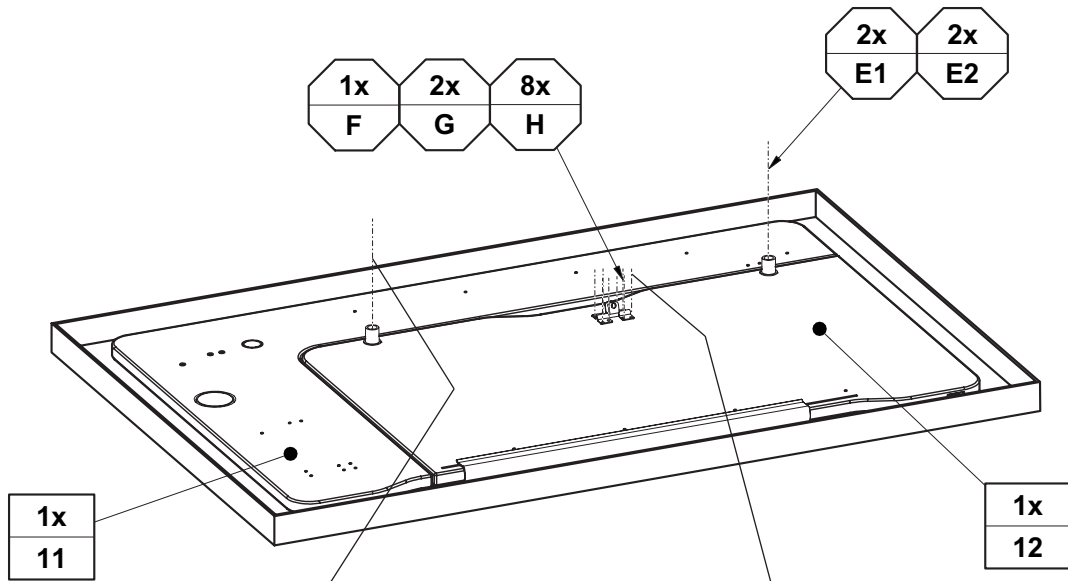
C  1x 671 7875	D  1x 671 7877	 2x 681 7765
---	---	---

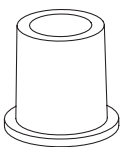

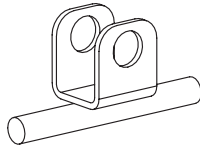
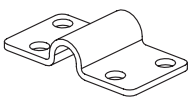
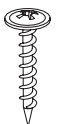
<p>E1</p>  <p>2x 681 5550</p>	<p>E2</p>  <p>4,0 x 40 2x 681 4911</p>	<p>F</p>  <p>1x 671 7879</p>	<p>G</p>  <p>2x 671 7880</p>	<p>H</p>  <p>4,0 x 20 8x 681 4917</p>
---	--	---	--	---

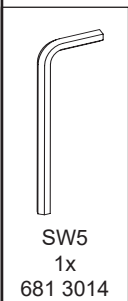
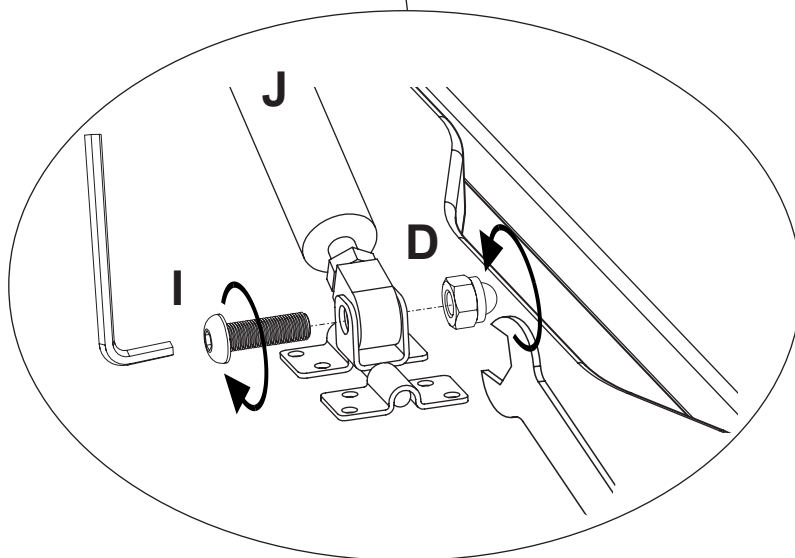
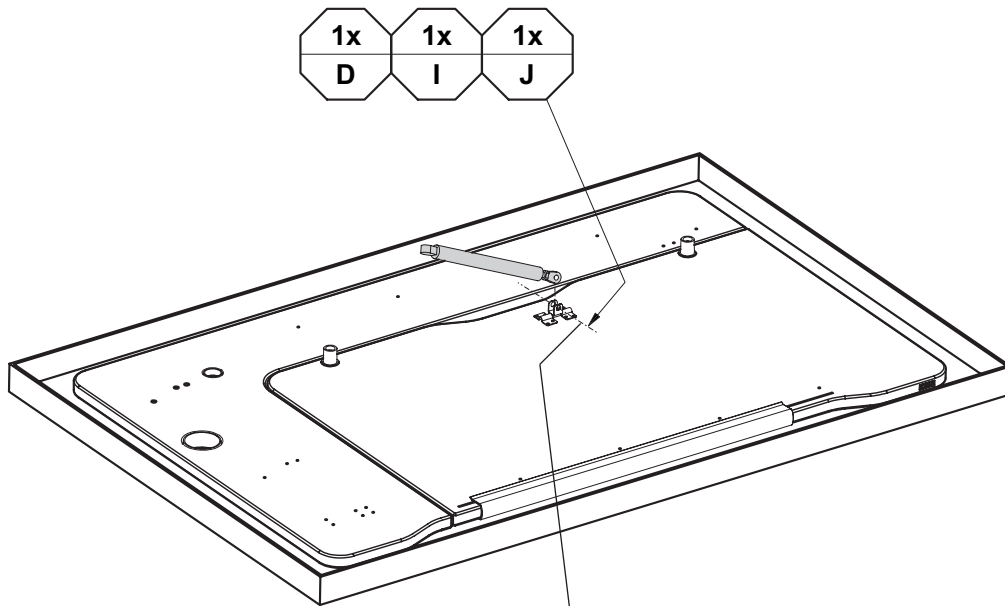

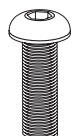
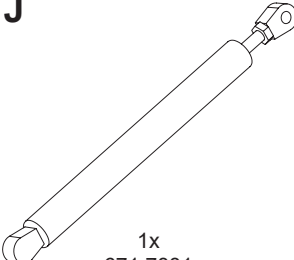
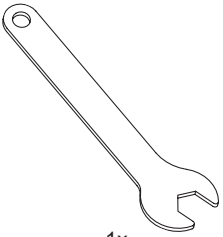
D  1x 671 7877	I  1x 671 7876	J  1x 671 7881	 1x 681 7765
---	---	---	---

M1

Montage / Assembly /
Assemblage / Montage / Монтаж /
组装 / Összeszerelés

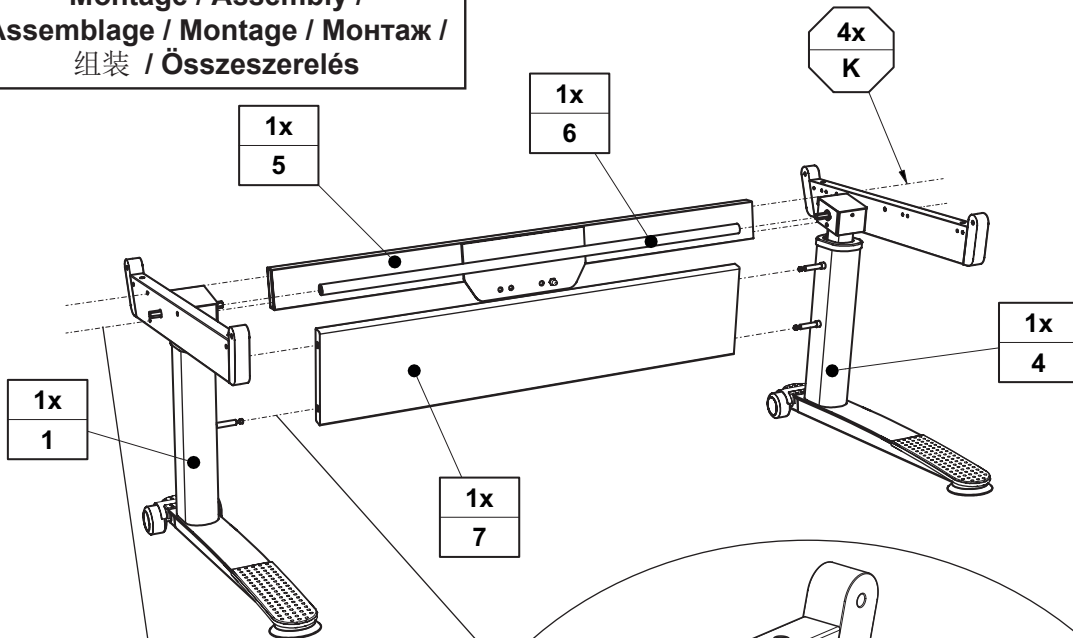

M1.1

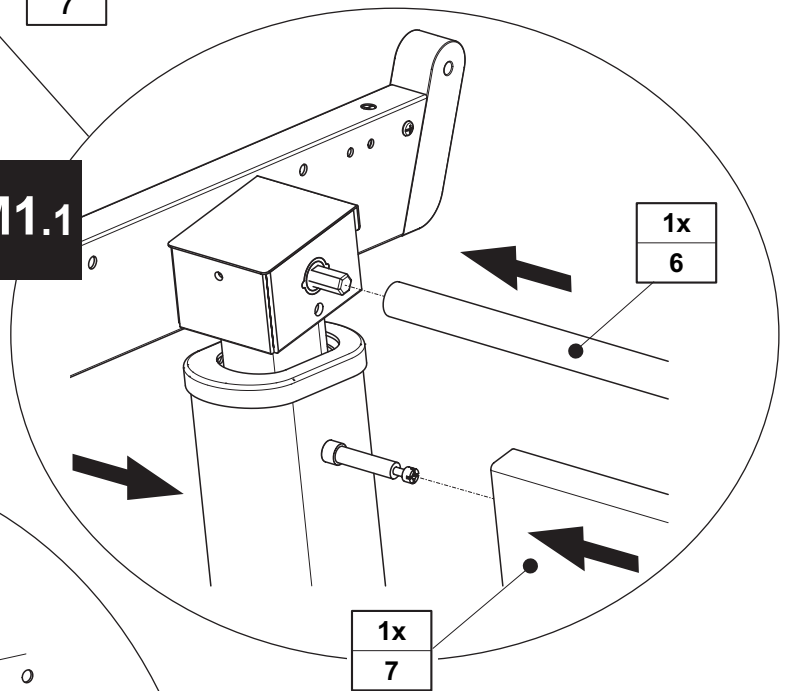

M1.2

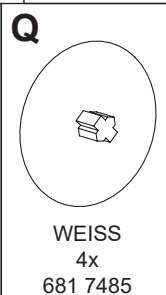
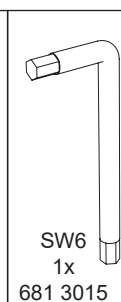
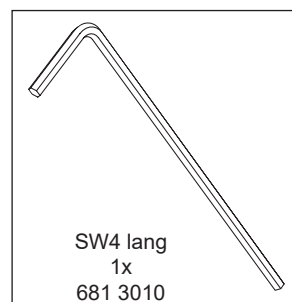
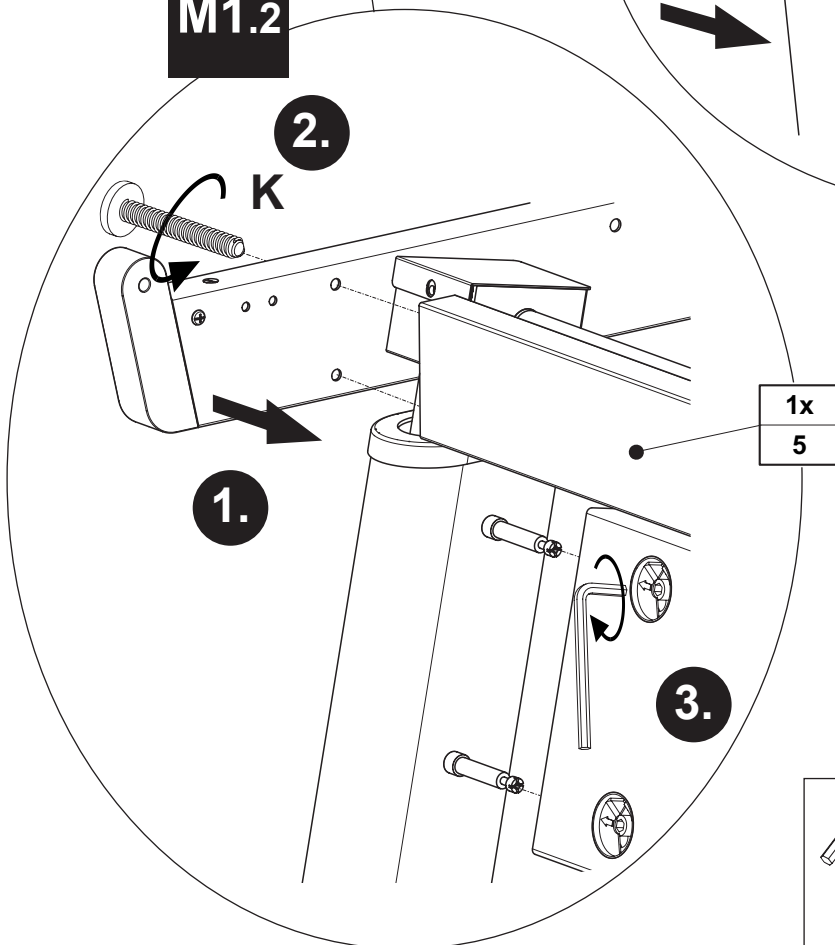



JARO
140 7341

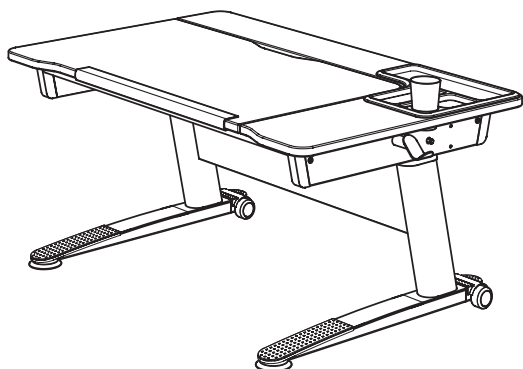

ACHTUNG! Aufbau ohne Schubkasten

PLEASE NOTE! Construction **without** drawer
 ATTENTION ! Structure **sans** tiroir
 LET OP! Opbouw **zonder** lades
 ВНИМАНИЕ! Монтаж **без** выдвижного ящика
 请注意! 无储物盒的装配
 FIGYELEM! Összeszerelés **fiók nélkül**

Seite 14 + 16

M2-3

JARO
140 7341 + JARO
140 8011
140 8081

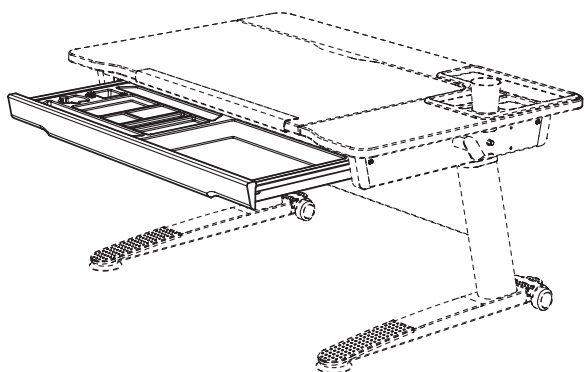

ACHTUNG! Aufbau mit Schubkasten

PLEASE NOTE! Construction **with** drawer
 ATTENTION! Structure **avec** tiroir
 LET OP! Opbouw **met** schuiflade
 ВНИМАНИЕ! Монтаж **с** выдвижным ящиком
 请注意! 带储物盒的装配
 FIGYELEM! Összeszerelés **fiókkal**

Seite 15 + 17

Schubkasten nicht im Lieferumfang, separat bestellen !
 Drawer not included, order separately !
 Les tiroirs ne sont pas inclus dans la livraison et doivent être commandés séparément !
 Lade niet inbegrepen, apart bestellen !
 Выдвижные ящики не входят в комплект поставки и заказываются отдельно !
 抽屉不包括在供货范围内, 请单独订购!
 A sublótfiókok nem tartoznak a szállítás terjedelmébe, ezeket külön kell megrendelni !

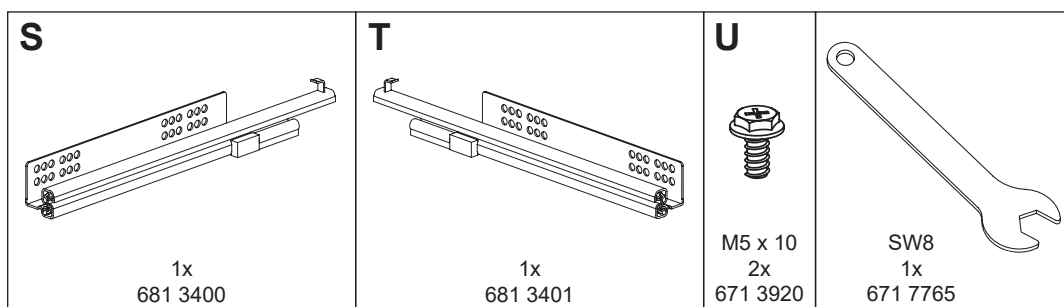

Seite 13 von 24

PK-Nr. 3623 Stand 04/2025

M2

ACHTUNG! Aufbau ohne Schubkasten

PLEASE NOTE! Construction **without** drawer
 ATTENTION ! Structure **sans tiroir**
 LET OP! Opbouw **zonder lades**
 ВНИМАНИЕ! Монтаж **без** выдвижного ящика
 请注意! 无储物盒的装配
 FIGYELEM! Összeszerelés fiók nélkül

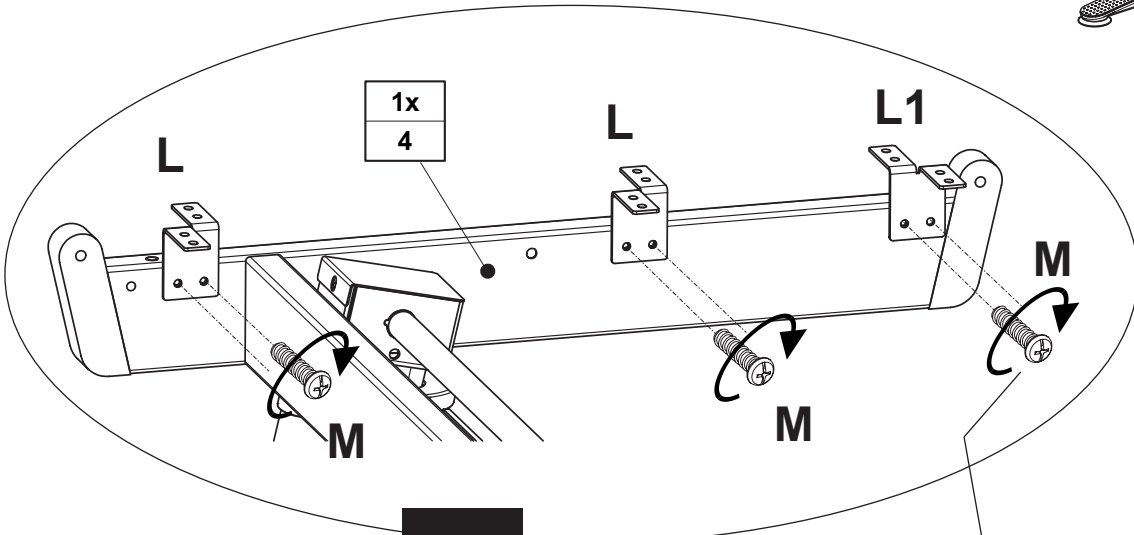
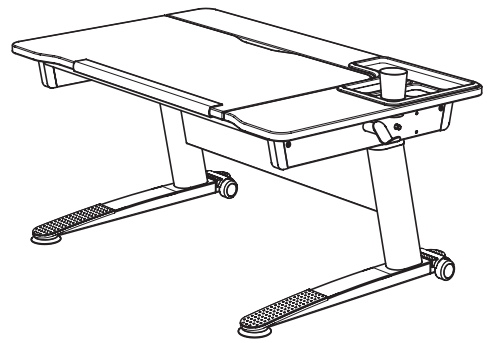

M2.2

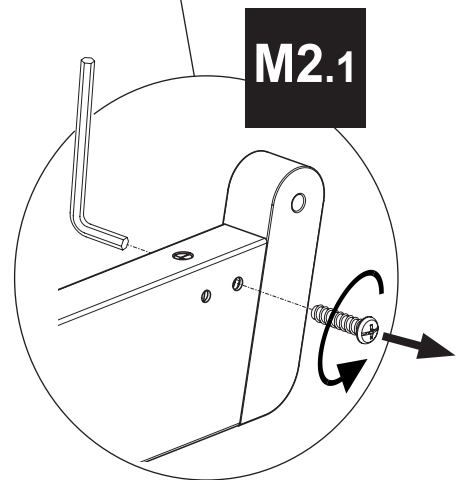

M2.1

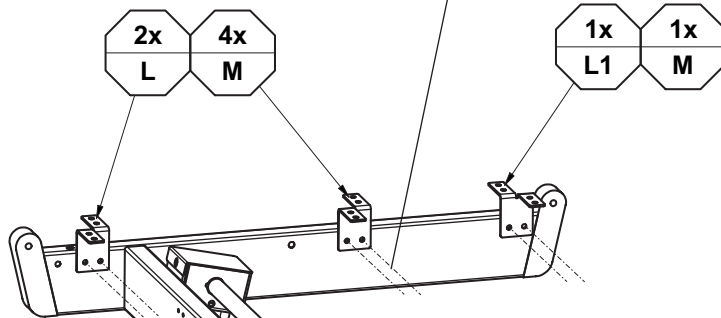

1x
4

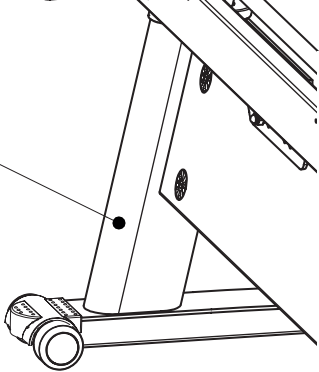

<p>L</p> <p>2x 671 7856</p>	<p>L1</p> <p>1x 671 7857</p>	<p>M</p> <p>M5 x 20 5x 671 7868</p>
--	---	--

ACHTUNG! Aufbau mit Schubkasten

M2

PLEASE NOTE! Construction with drawer
 ATTENTION! Structure avec tiroir
 LET OP! Opbouw met schuiflade
 ВНИМАНИЕ! Монтаж с выдвижным ящиком
 请注意! 带储物盒的装配
 FIGYELEM! Összeszerelés fiókkal

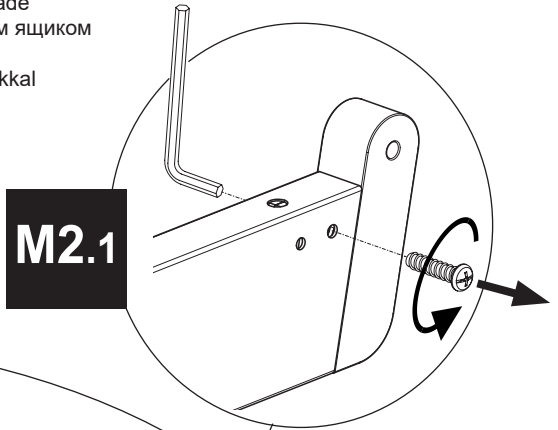
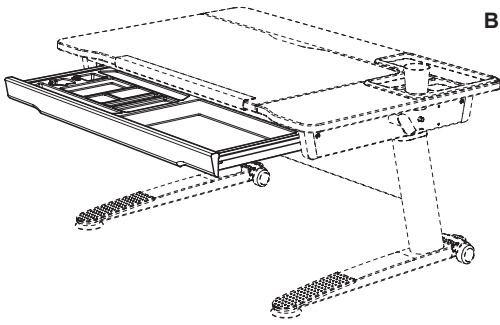

M2.1

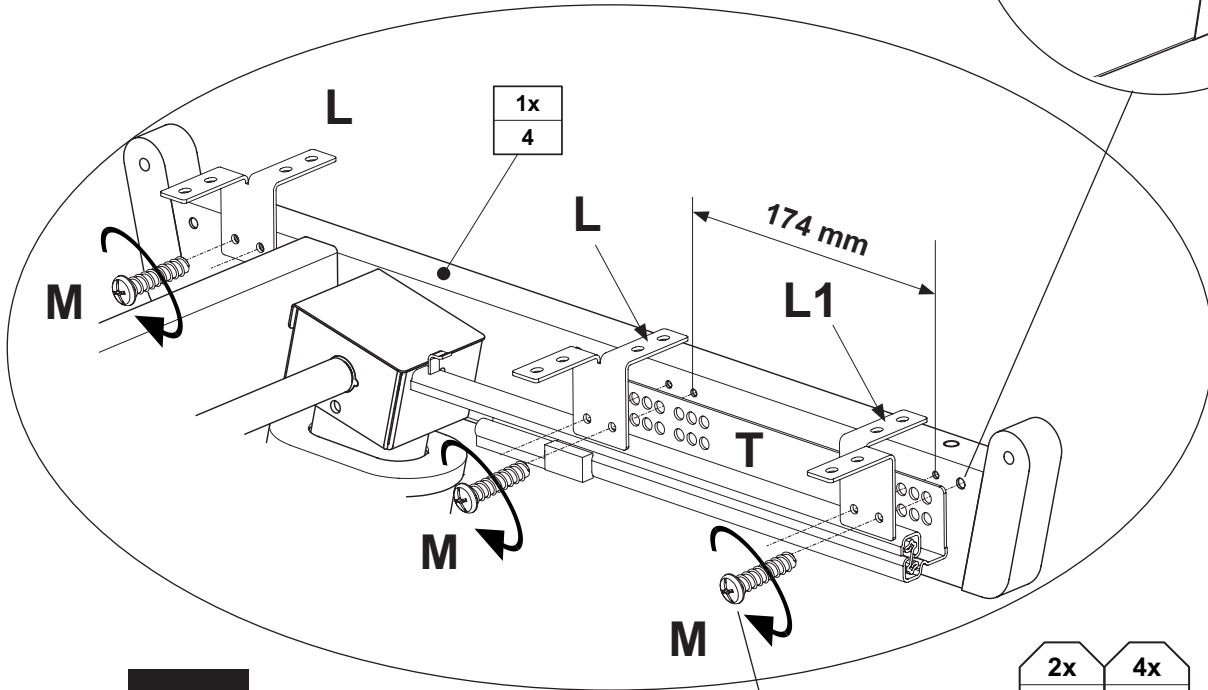

M2.2

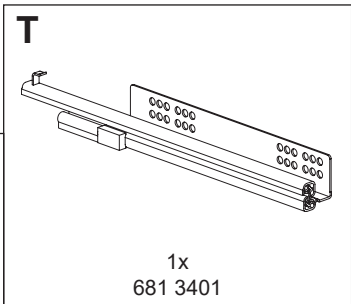
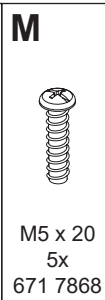
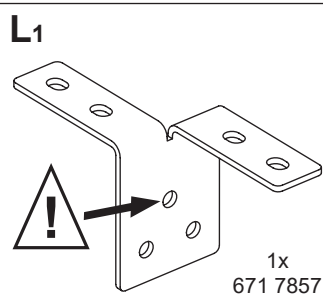
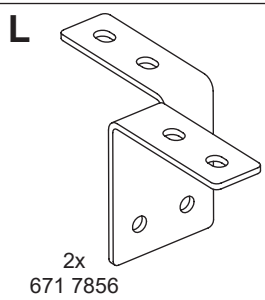
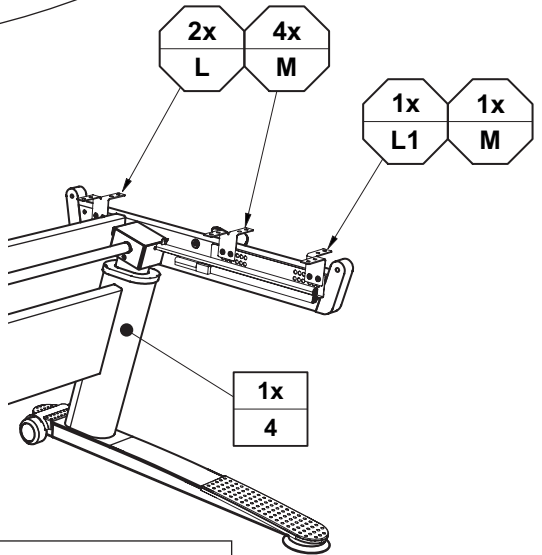
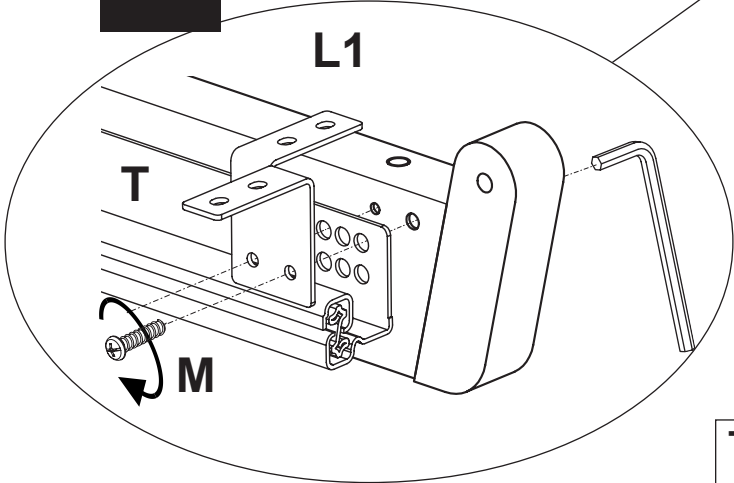

ACHTUNG! Aufbau ohne Schubkasten

PLEASE NOTE! Construction **without** drawer
 ATTENTION ! Structure **sans** tiroir
 LET OP! Opbouw **zonder** lades
 ВНИМАНИЕ! Монтаж **без** выдвижного ящика
 请注意! 无储物盒的装配
 FIGYELEM! Összeszerelés **fiók** nélkül

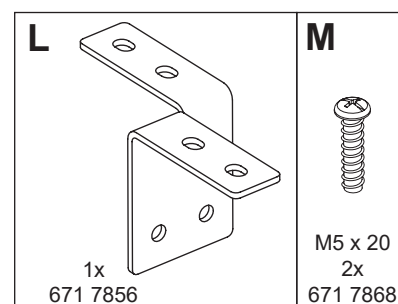
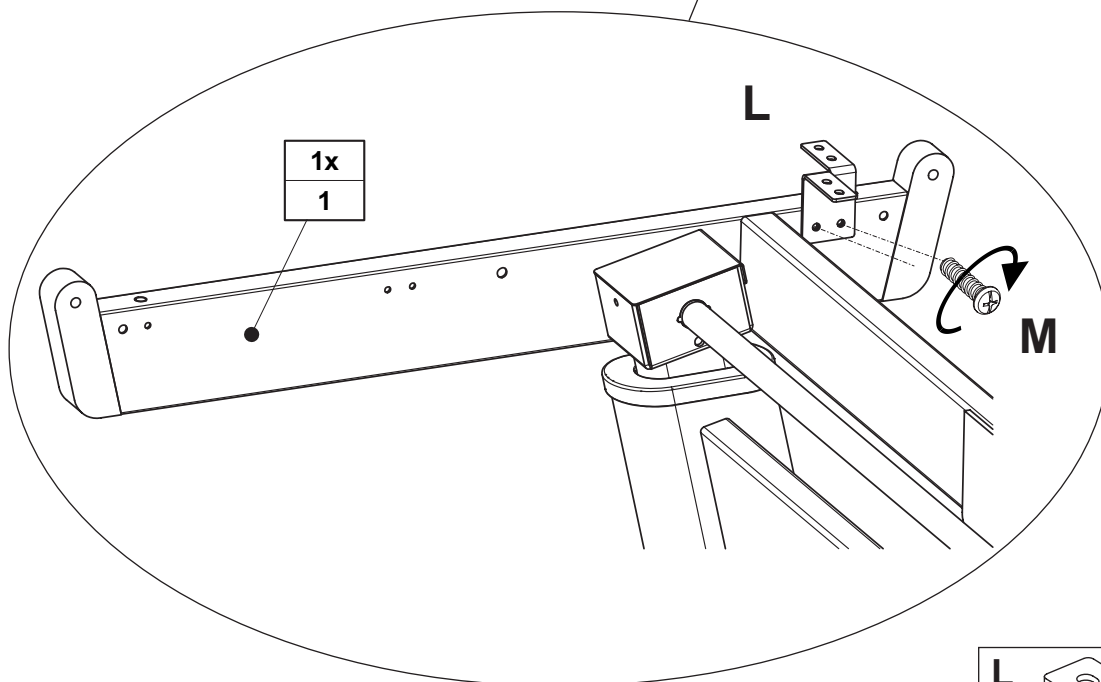
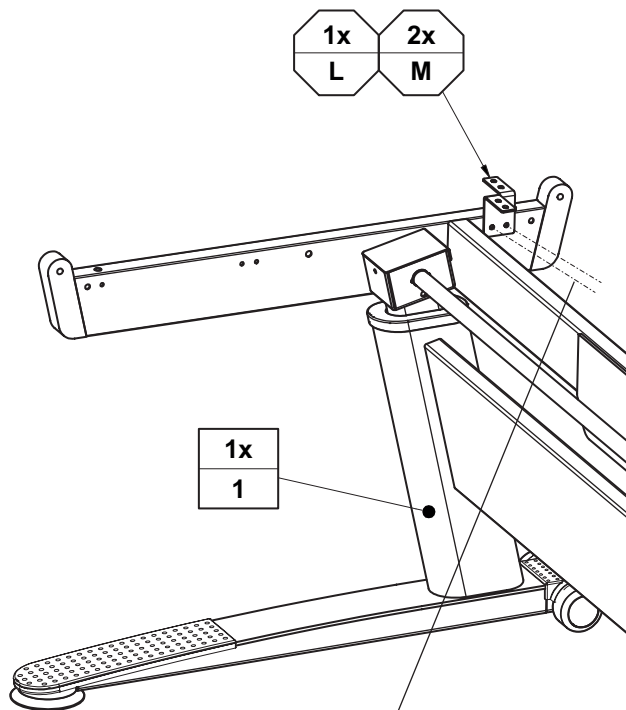
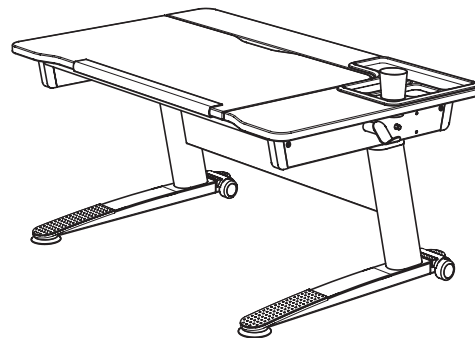

ACHTUNG! Aufbau mit Schubkasten

M3

PLEASE NOTE! Construction with drawer
 ATTENTION! Structure avec tiroir
 LET OP! Opbouw met schuiflade
 ВНИМАНИЕ! Монтаж с выдвижным ящиком
 请注意! 带储物盒的装配
 FIGYELEM! Összeszerelés fiókkal

1x L
 2x M

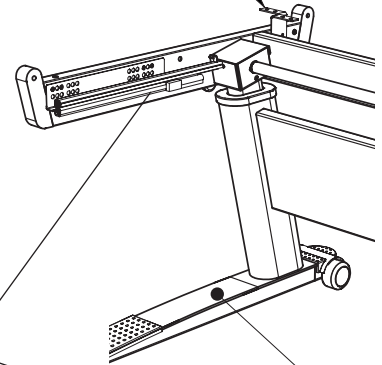
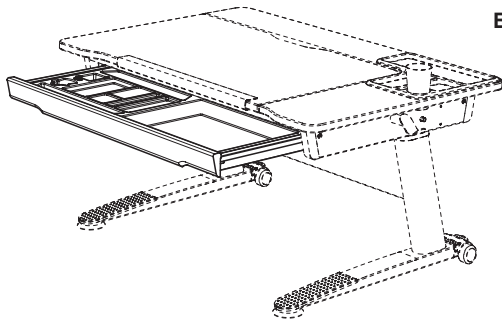

1x
 1

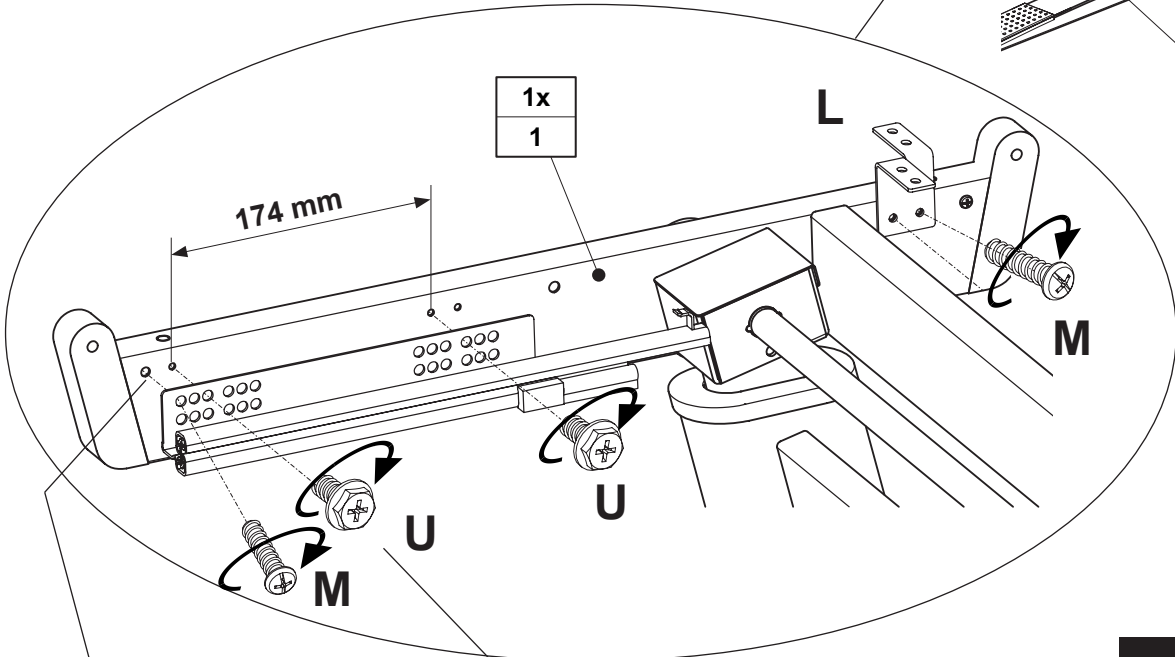

1x
 1

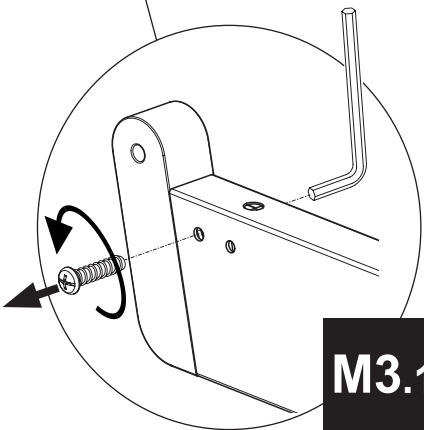

M3.1

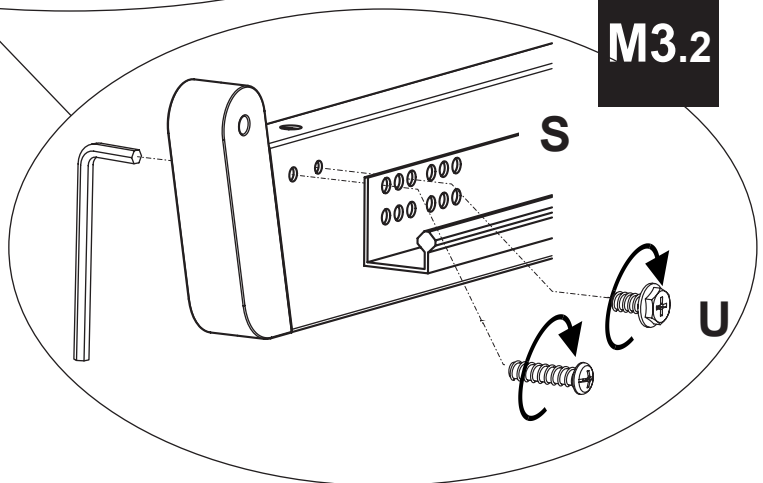

M3.2

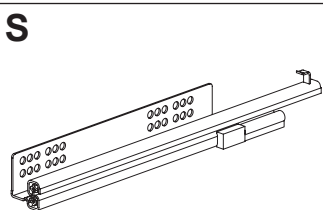

1x
 681 3400



M5 x 10
 2x
 671 3920

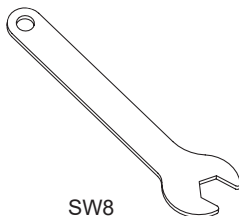

SW8
 1x
 671 7765

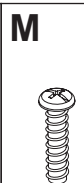

M5 x 20
 2x
 671 7868

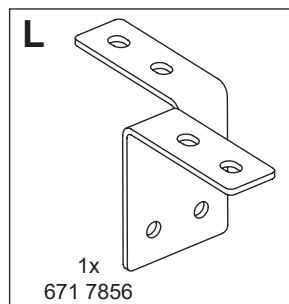

1x
 671 7856

M4

M4.2

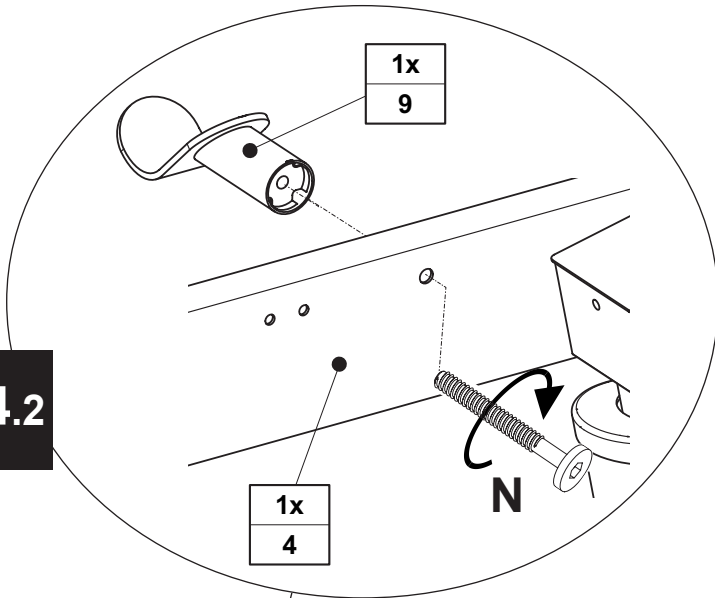

1x
9

301 mm



1-2 mm

N

M4.1

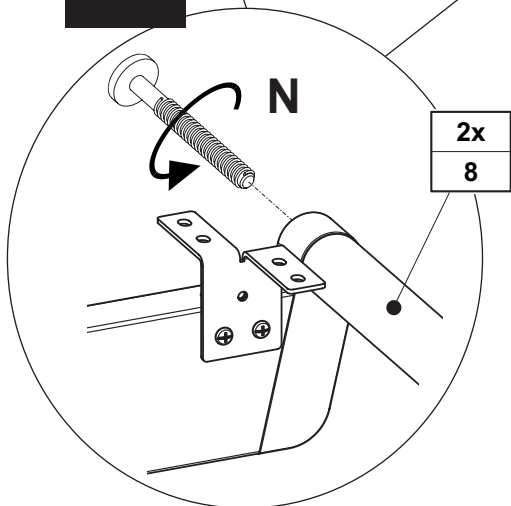



2x
8

2x
8

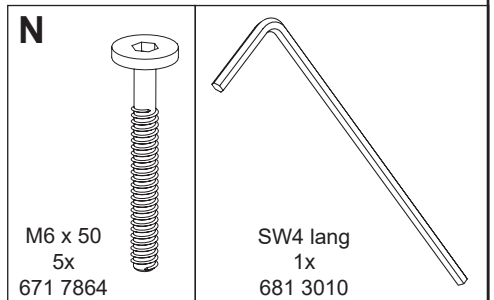
5x
N

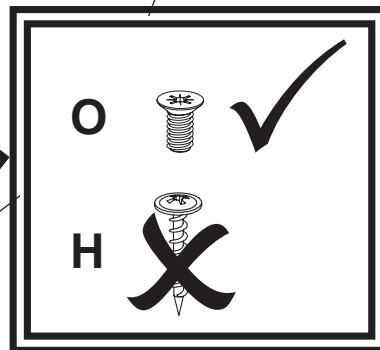
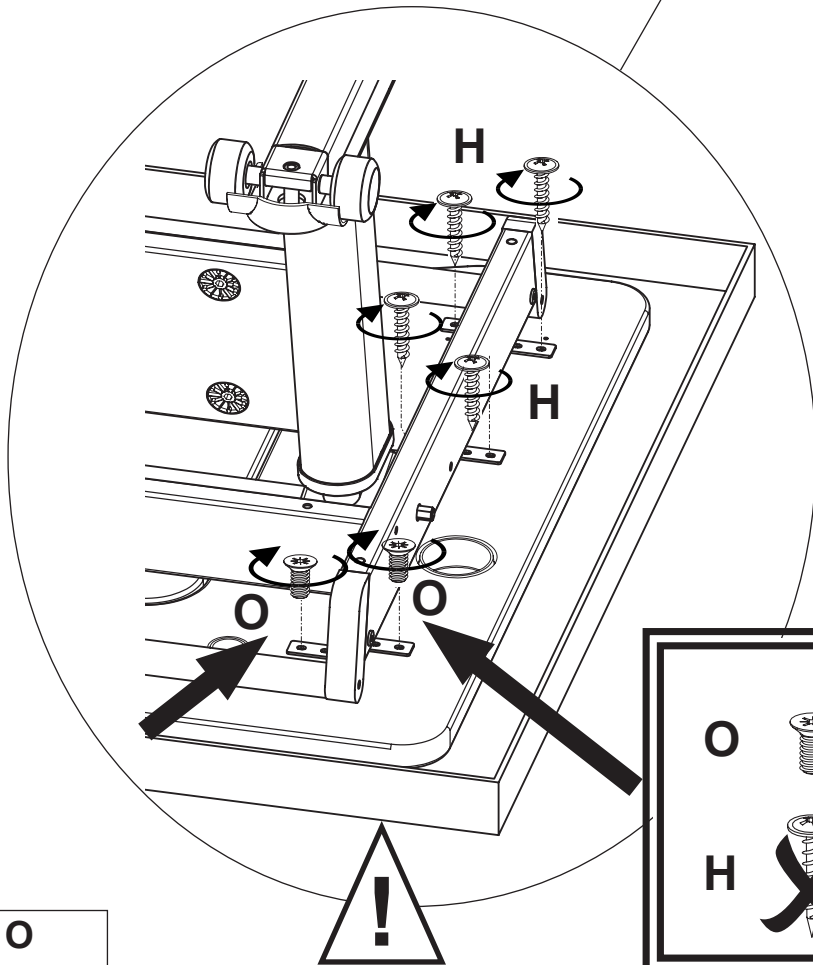
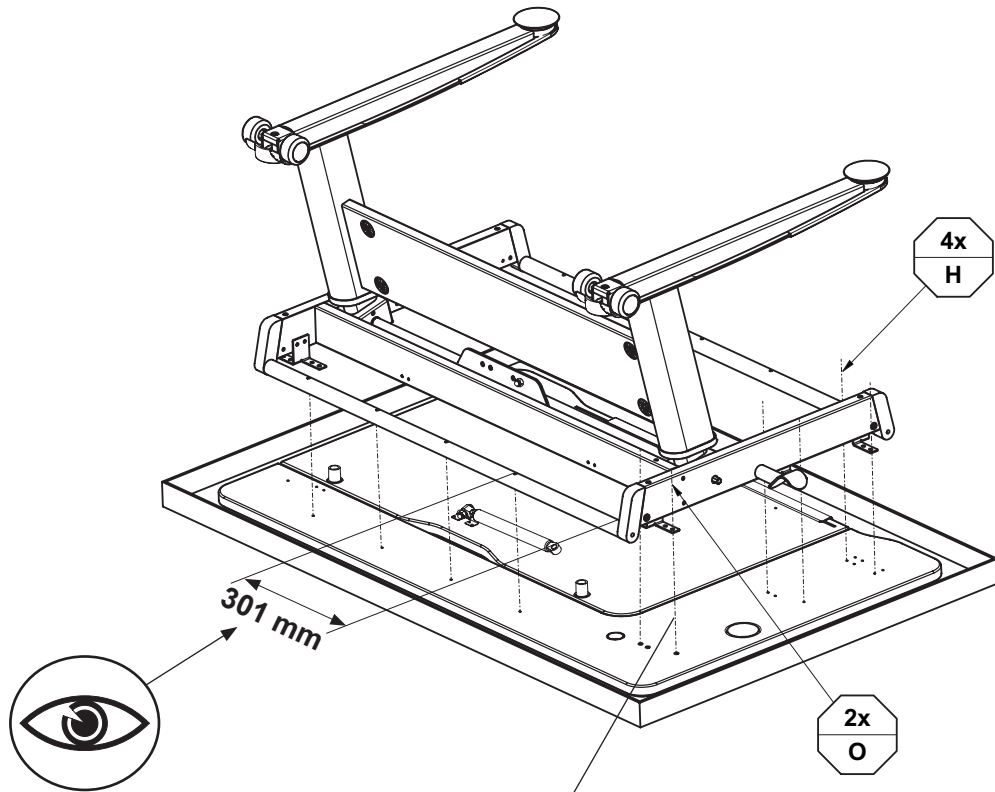

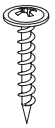

H	O
	
4,0 x 20 4x 681 4917	M5 x 10 2x 681 3930

M6

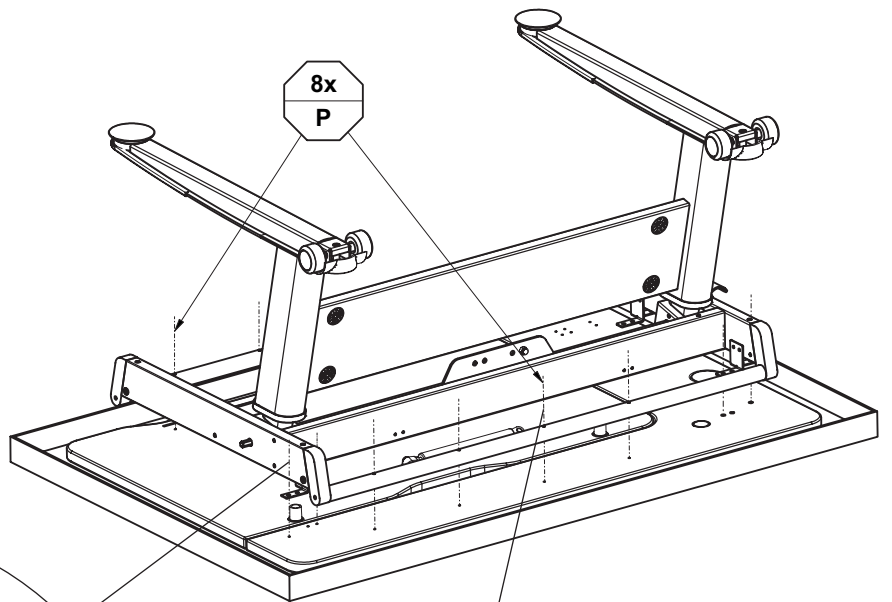

M6.1

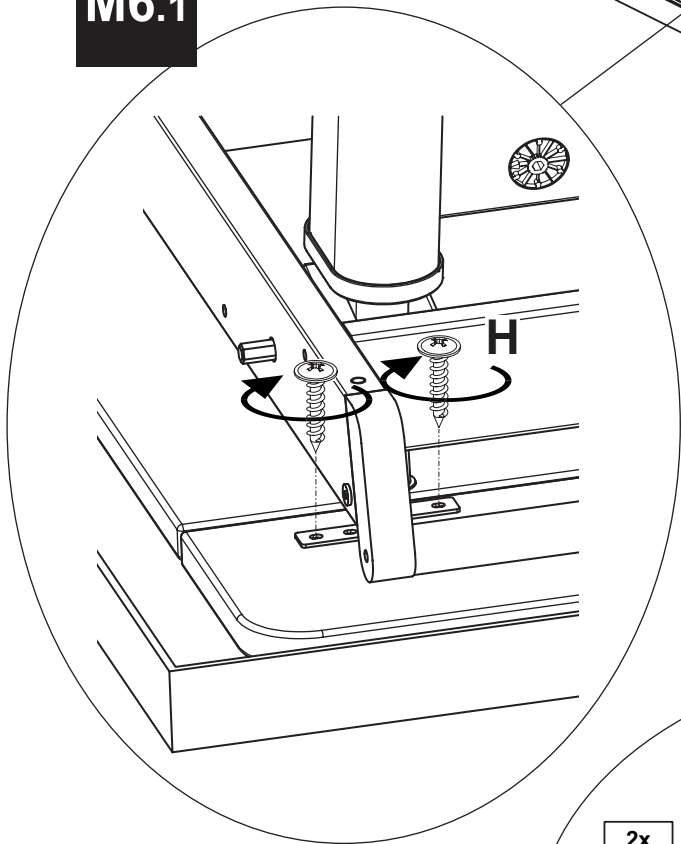

M6.2

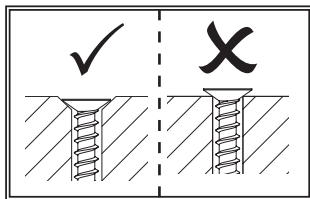
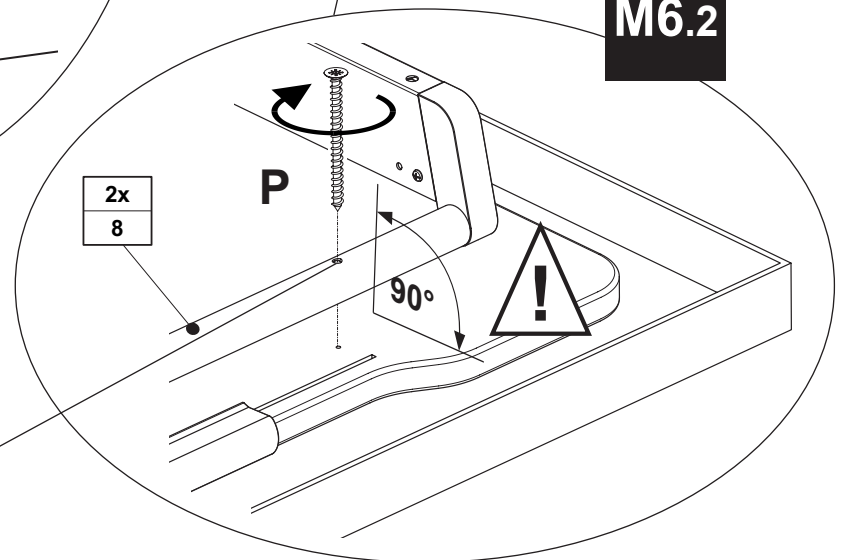

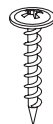
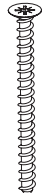
H	P
	
4,0 x 20 2x 681 4917	4,0 x 45 8x 681 4893

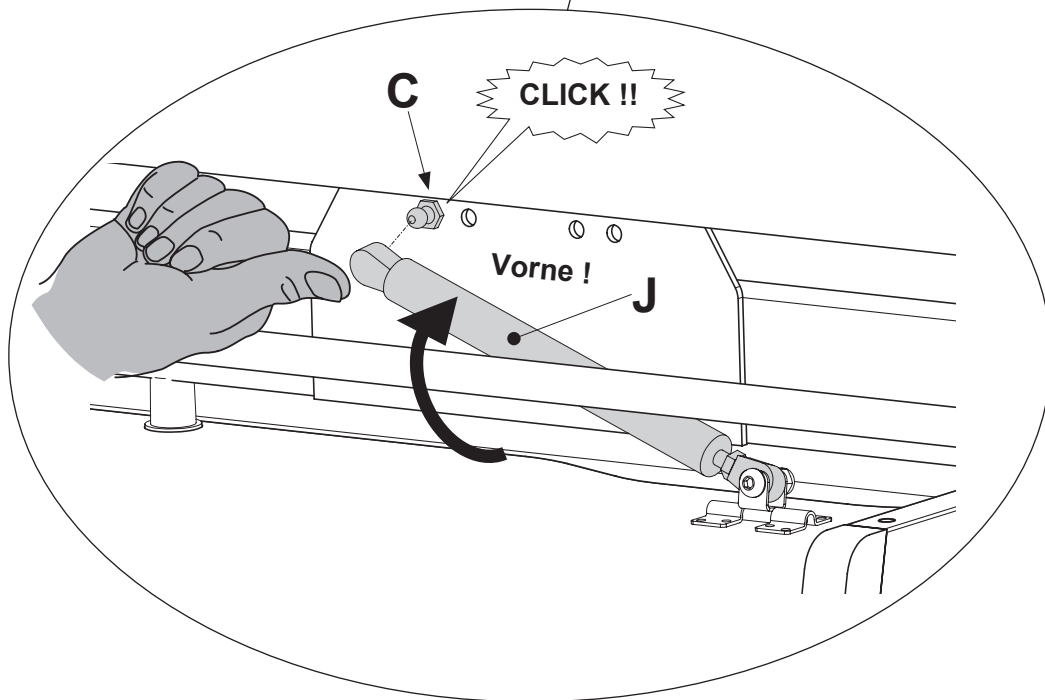
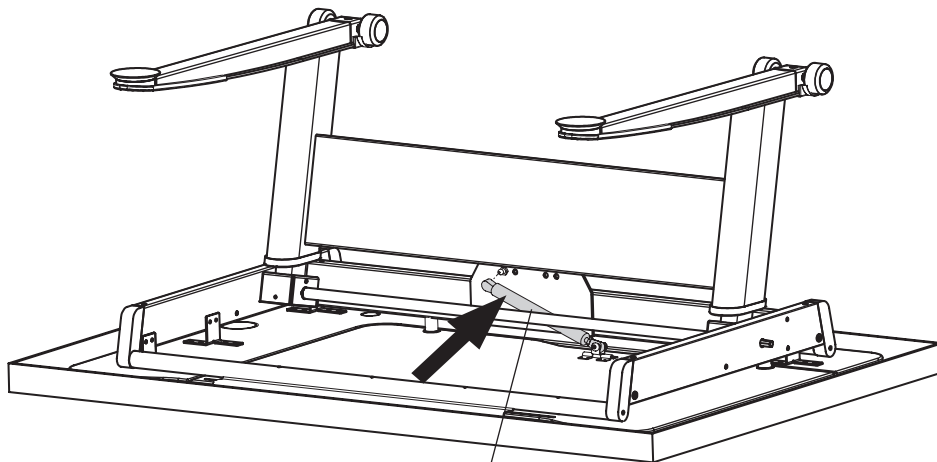

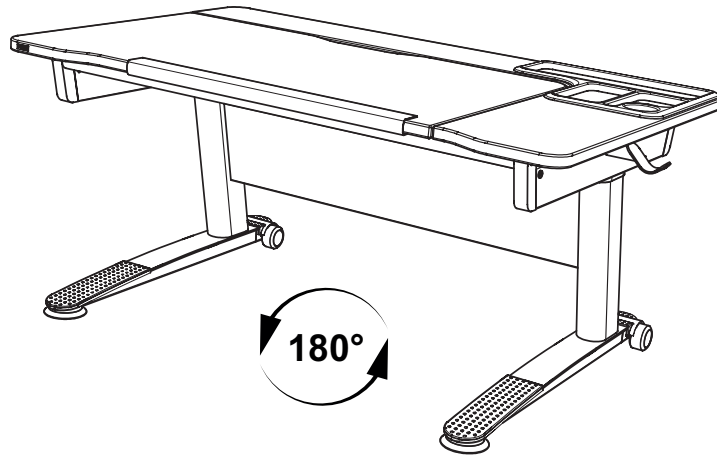

**Schrägstellung / Inclined position
/ Inclinaison / Schuine stand /
Наклонное положение / 倾斜位置
/ Ferdére állítás**

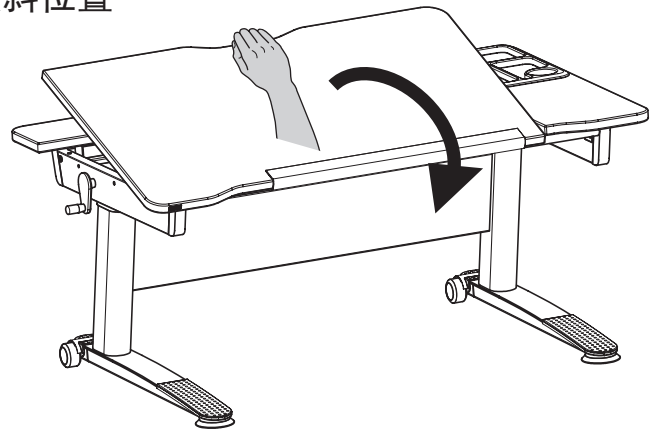

1.

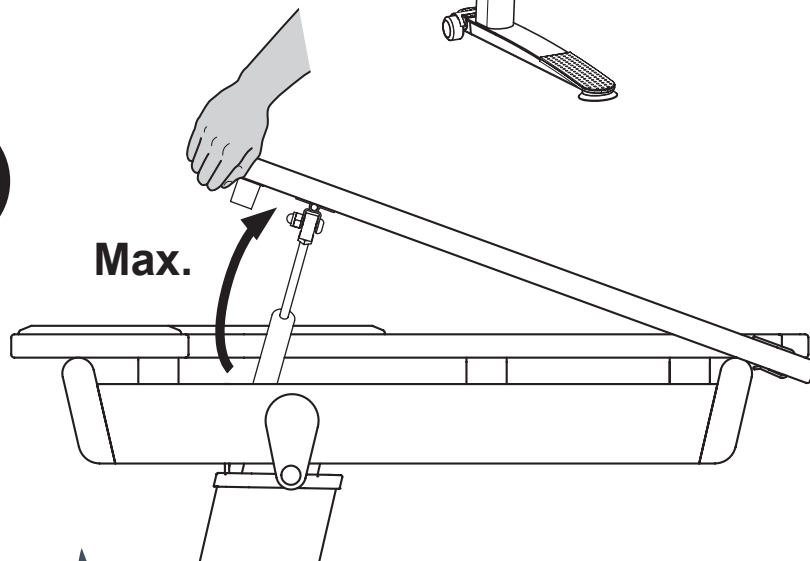

2.

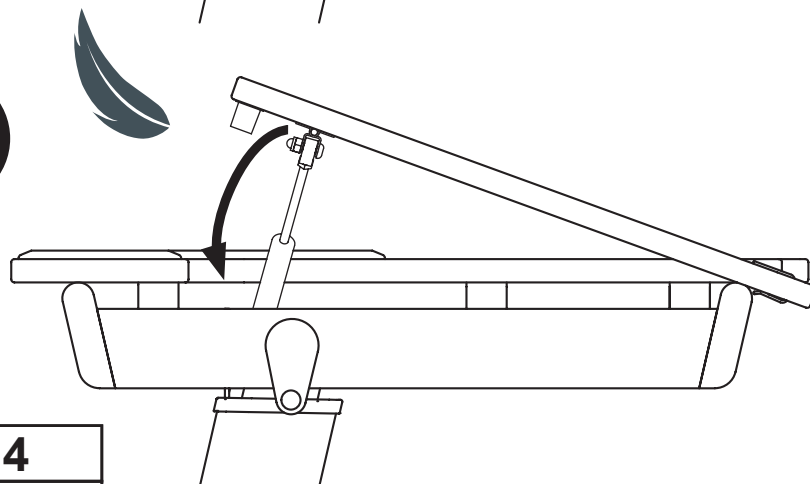

M9

1x
10

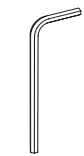
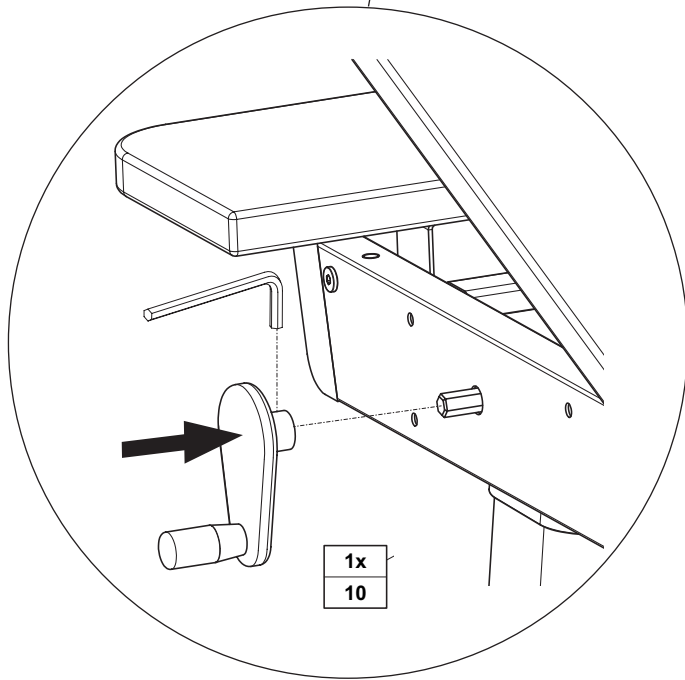

SW2,5
1x
671 3005

1x
14

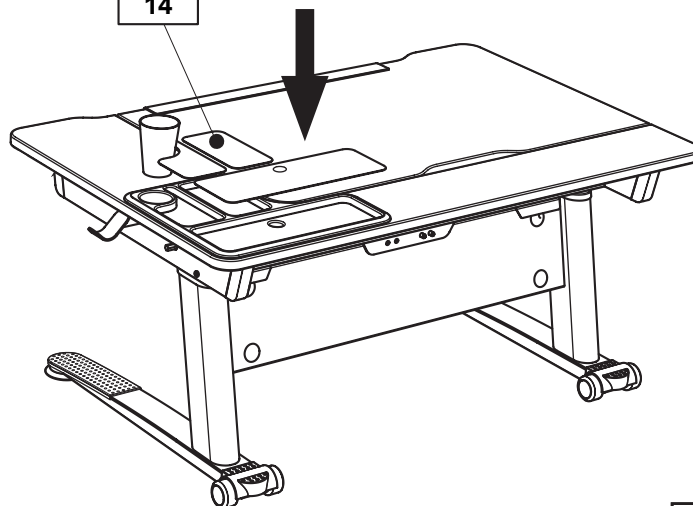

M10

Seite 23 von 24

PK-Nr. 3623 Stand 04/2025

Höheneinstellung Empfehlungswerte

Recommended values for height adjustment / Réglage de la hauteur Valeurs recommandées / Hoogte-instelling advieswaarden / Рекомендуемые значения настроек высоты / 高度调整建议值 / A magasság beállítása - Ajánlott értékek

PAIDI Möbel GmbH
Hauptstraße 87
97840 Hafenhöhr
Germany
info@paidi.de



< 142 cm	53 – 58 cm	30 – 34 cm
143 – 157 cm	59 – 64 cm	35 – 38 cm
158 – 172 cm	65 – 70 cm	39 – 44 cm
> 172 cm	71 – 79 cm	> 45 cm

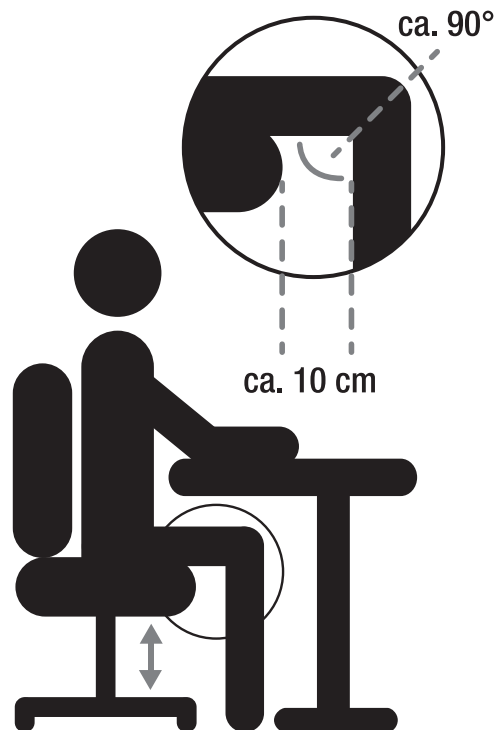

Höhenverstellung / Height adjustment / Réglage de la hauteur / Hoogtever- stelling / Регулировка высоты / 高度调整 / Magasság beállítása

