

5EEH1254

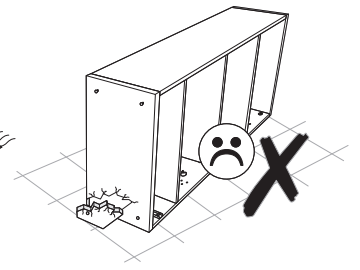
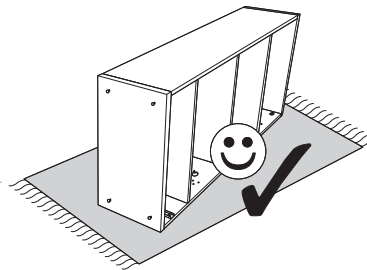
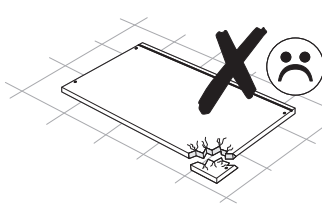
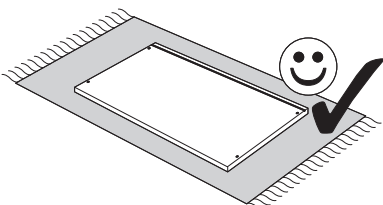
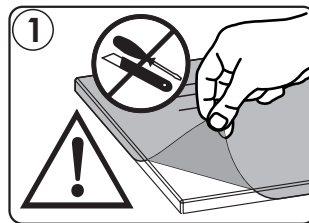
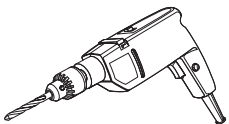
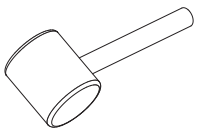
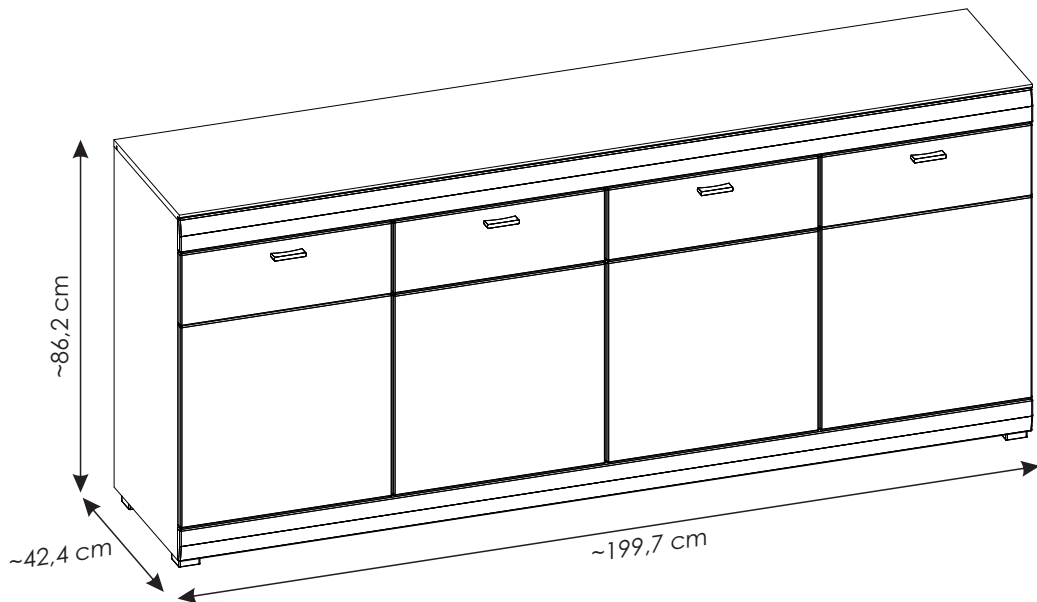
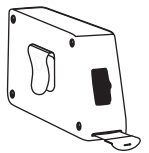
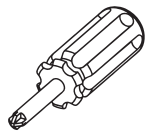
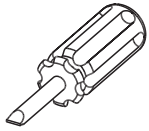
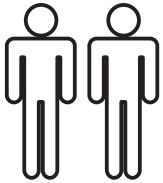

PL.

UWAGA! Mebel należy trwale zamocować do ściany, aby uniknąć ryzyka związanego z przewróceniem się mebla.

W paczce nie ma śrub mocujących, ponieważ rodzaj mocowania należy odpowiednio dobrać do rodzaju ściany. Dobierz właściwe do Twojego rodzaju ściany.

D.

ACHTUNG! Um alle mit dem Umkippen des Möbels verbundenen Risiken auszuschließen, muss das Möbel fest an der Wand verankert werden. Beschläge für die Wandbefestigung sind nicht beige packt, da diese von der jeweiligen Wandbeschaffenheit abhängig sind. Bitte solche Befestigungsschläge wählen, die für die heimischen Wände geeignet sind.

FR.

ATTENTION! Ce meuble doit être fixé en permanence au mur pour éviter les risques de chute. Les vis de fixation ne sont pas livrées car le type de fixation doit être choisi en fonction du type de mur. Sélectionnez les fixations adaptées au mur.

I.

ATTENZIONE! Il mobile deve essere permanentemente fissato alla parete per evitare i rischi derivanti da un ribaltamento del mobile. La confezione non include le viti di fissaggio, in quanto il tipo di fissaggio deve essere scelto in base al tipo di parete. Utilizzare viti appropriate in base al materiale della parete.

HR.

NAPOMENA! Namještaj mora biti trajno pričvršćen za zid, kako bi se izbjegao rizik od njegovog prevrtanja. U paketu nema vijaka za pričvršćivanje, jer se vrsta montaže mora prilagoditi vrsti zida. Odaberite pravu vrstu prema Vašoj vrsti zida.

EN.

WARNING! To prevent this furniture from tripping over, fix it to the wall permanently. Fixing devices are not included since different wall materials require different types of fixing devices. Please make sure you chose the correct ones for your type of wall.

SK.

POZOR! Nábytok musí byť trvalo pripevnený k stene tak, aby sa zamedzilo riziku prevrátenia. Balík neobsahuje upevňovacie skrutky, pretože typ upevnenia je treba vybrať podľa typu steny. Vyberte typ vhodný pre Vašu stenu.

CZ.

POZOR! Nábytek je nutné pevně připevnit ke zdi, abychom se vyhnuli riziku spojenému s jeho převrnutím. Součástí balení nejsou připevňovací šrouby, protože způsoby připevnění je nutné zvolit podle druhu stěny. Vyberte správný pro Váš typ stěny.

RU.

ПРИМЕЧАНИЕ! Эту мебель необходимо всегда прикреплять к стене, чтобы избежать рисков, связанных с переворотом мебели. В пакете нет крепежных винтов, потому что тип крепления должен быть выбран в соответствии с типом стены. Выберите, пожалуйста, правильные винты к вашей стене.

RO.

ATENȚIE! Mobila trebuie ancorată permanent în perete pentru a evita riscul de răsturnare a mobilei. În pachet nu sunt incluse șuruburile de fixare, deoarece tipul de ancoraj trebuie ales în funcție de tipul de perete. Alegeți șuruburile potrivite pentru tipul Dvs. de perete.

TR.

DİKKAT! Devrilme riskini önlemek için mobilya duvara sabitlemelidir. Sabitleme civataları pakete dahil değil, çünkü sabitleme tertibatının tipi, duvara tipine uygun olarak seçilmelidir. Onu duvarınızın tipine göre seçiniz.

AR.

ملاحظة!

يجب تثبيت الأثاث بإحكام إلى الحائط أو الجدار لتجنب خطر إنقلابه. لا تحتوي العلبة على مسامير التثبيت، إذ إنه ينبغي إستعمال المسامير المخصصة لنوعية الحائط أو الجدار. اختر المسامير التي تناسب جدارك.

E.

¡ATENCIÓN! El mueble debe ser fijado permanentemente a la pared para evitar el riesgo relacionado con el vuelco del mueble. En el paquete no hay tornillos de fijación, ya que se debe elegir el tipo de fijación adecuado para el tipo de pared. Elija el apropiado para su tipo de pared.

CN.

注意！本家具需要固定在墙上以免倒塌。箱子里没有安装螺钉。因为安装方式需要根据墙的类型调整。请按照您的墙类型选择合适的安装方式。

SLO.

POZOR! Pohištvo trajno pritrdite na steno, da preprečite tveganje, da se prevrne. V paketu ni pritrdilnih vijakov, saj je treba način pritrditve ustrezno izbrati glede na vrsto stene. Izberite način, ki je ustrezen za vašo steno.

HU.

FIGYELEM! Rögzítse a bútorokat a falhoz, hogy elkerülje a bútor felborulásának kockázatát. A készletben nem találhatóak rögzítőcsavarok, mivel a rögzítés típusa a fal típusától függ. Válassza ki a fal típusának megfelelő kötőelemeket.

NL.

OPMERKING! De meubelen moeten permanent aan de muur worden bevestigd om te voorkomen dat de meubelen kantelen. Er zitten geen bevestigingsschroeven in het pakket, omdat het type bevestiging moet worden gekozen op basis van het type muur. Kies de juiste voor uw type muur.

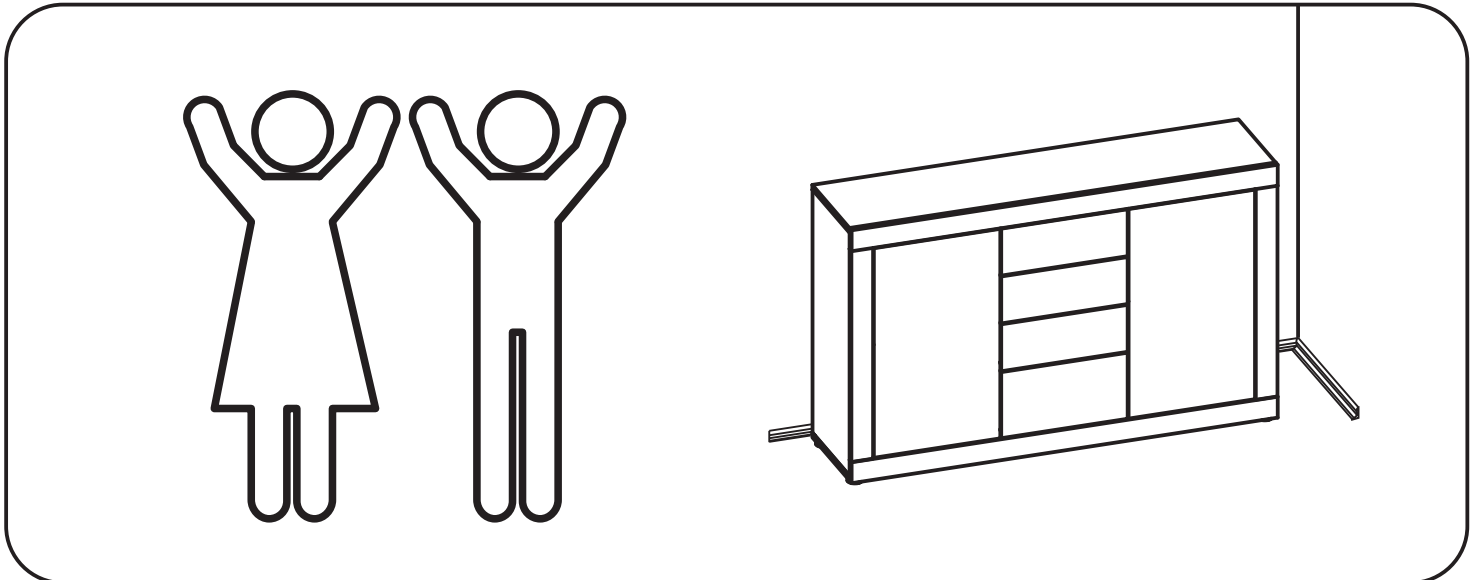
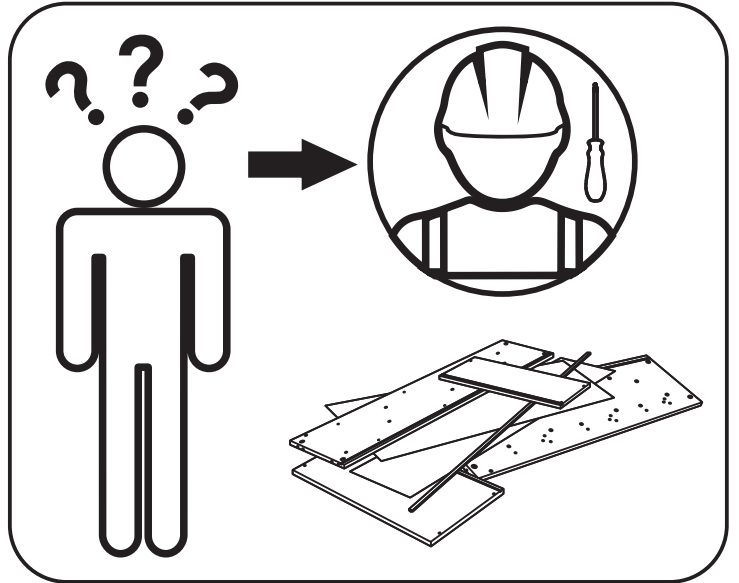
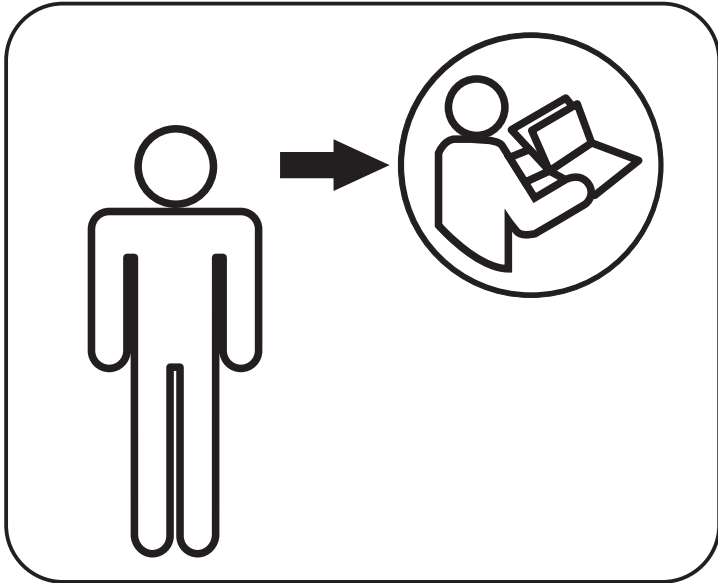
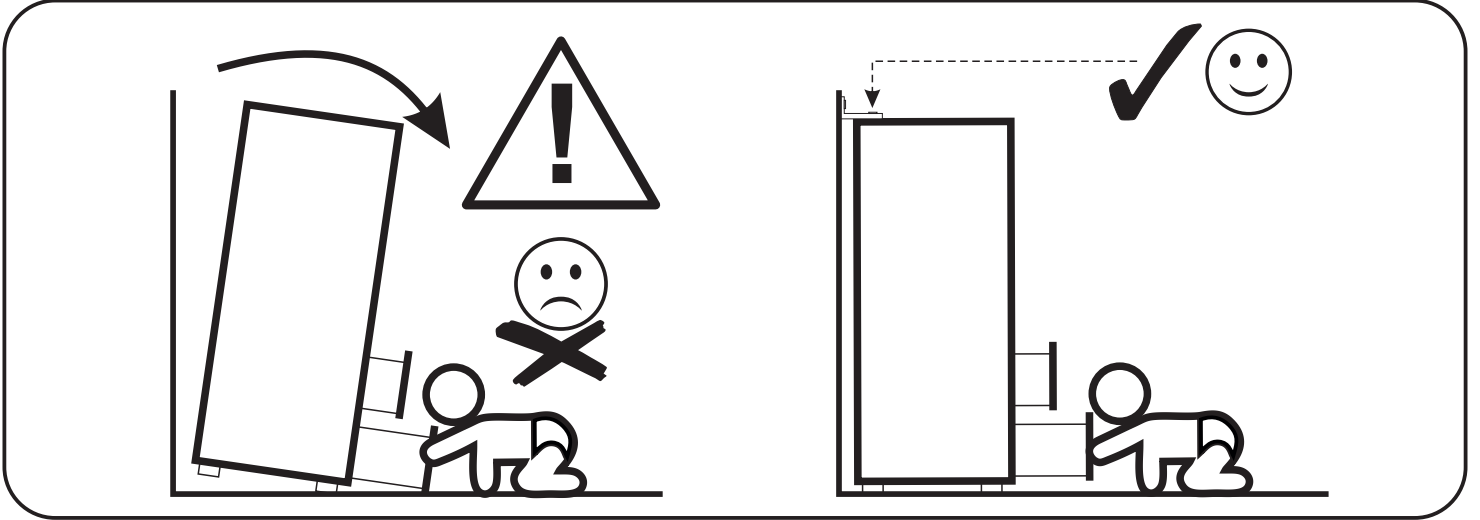
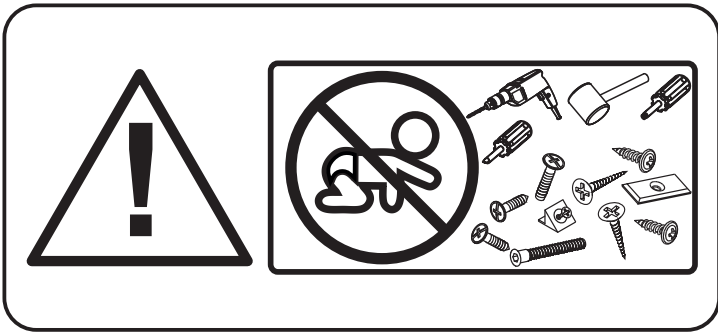



version A



version B

Bx

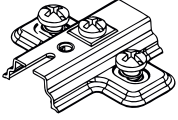

Bx

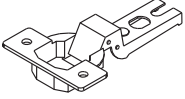

BCxx

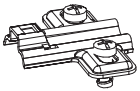

BCxx

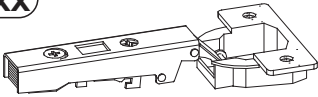

Bx + Bx

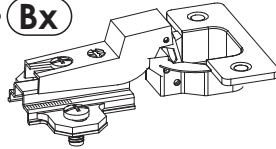

Bx

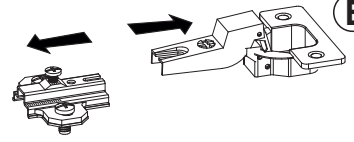

Bx

BCxx

BCxx + BCxx

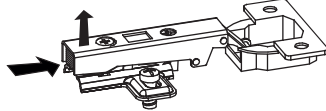

BCxx



BCxx

Bx

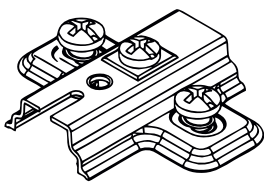

OK

Bx

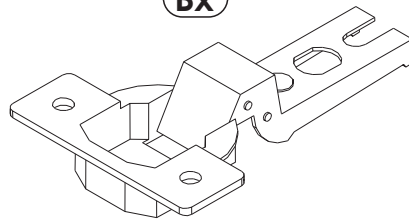

BCxx

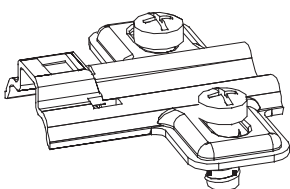





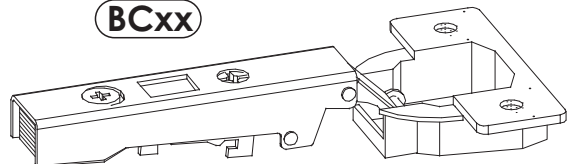



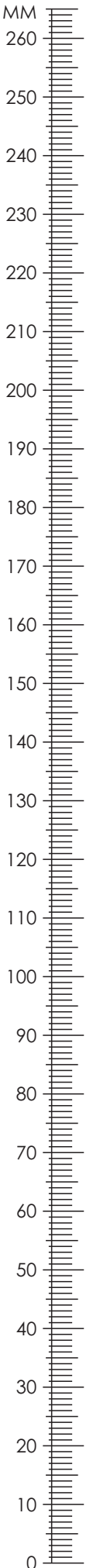



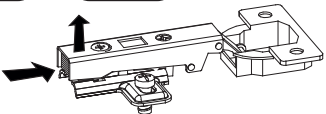
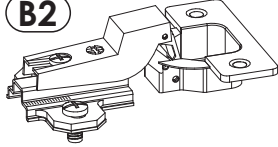

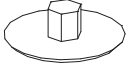
OK

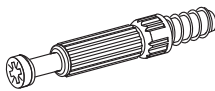
BCxx

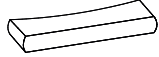

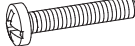
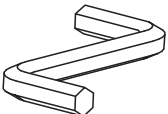
5EEH1254

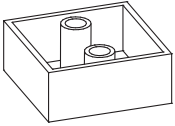

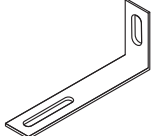
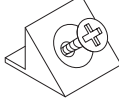
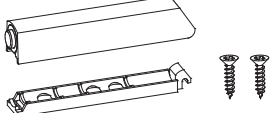
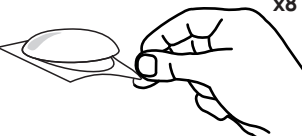
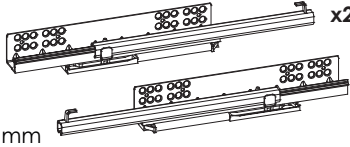
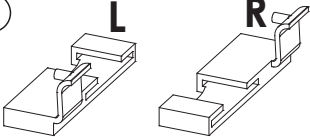
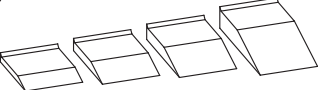
A1 8 x 35 mm x46 	A2 8 x 45 mm x4 	BC11 + BC12 x4 
B0 + B2 x4 	C2 5 x 13 mm x24 	D2 x16 
E0 Ø16 x23 	E1 15 x 12 mm x36 	F1 6 x 34 mm x28 
F5 7 x 64 mm x4 	G1 7 x 50 mm x10 	H1 L - 75 mm x4 
I2 4 x 16 mm x17 	I4 3,5 x 27 mm x11 	K7 4 x 22 mm x8 
M x1 	N1 3 x 16 mm x10 	O6 x4 
O1 x3 	Q9 x2 	R4 x14 
R6 x2 	R8 x8 	T12 x2 L - 350 mm 
TZ L R x2 	Z x1 	

5EEH1254

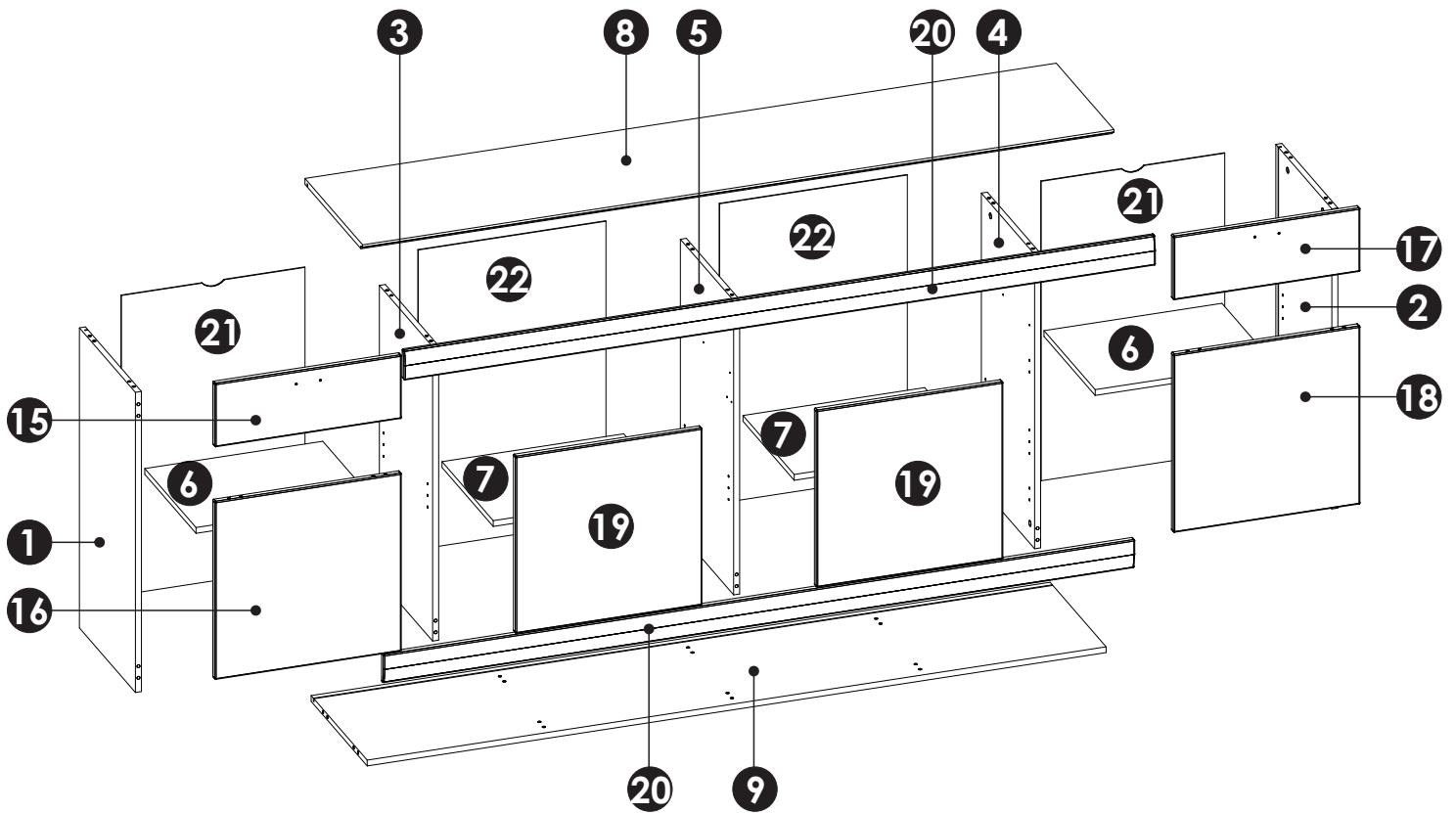
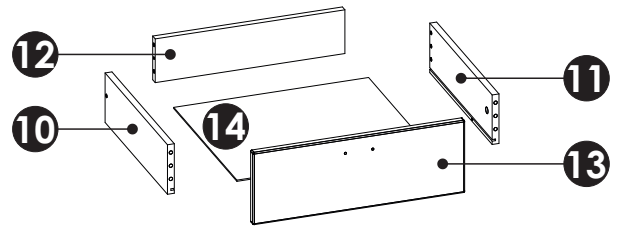
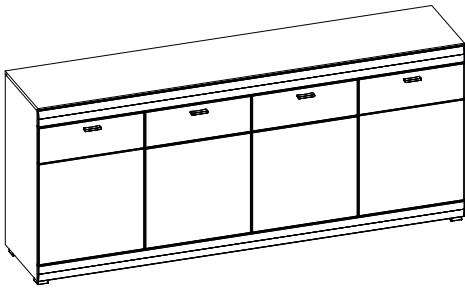

1	826	408	16	x1	2/3
2	826	408	16	x1	2/3
3	810	388	16	x1	2/3
4	810	388	16	x1	2/3
5	810	388	16	x1	2/3
6	473	373	16	x2	1/3
7	483	373	16	x2	1/3
8	1997	420	16	x1	3/3

9	1964	408	16	x1	3/3
10	350	120	16	x2	1/3
11	350	120	16	x2	1/3
12	444	106	16	x2	1/3
13	496	175	16	x2	1/3
14	456	355	3	x2	3/3
15	496	175	16	x1	1/3

16	496	490	16	x1	1/3
17	496	175	16	x1	1/3
18	496	490	16	x1	1/3
19	496	487	16	x2	1/3
20	1997	80	16	x2	3/3
21	824	488	3	x2	3/3
22	824	499	3	x2	3/3

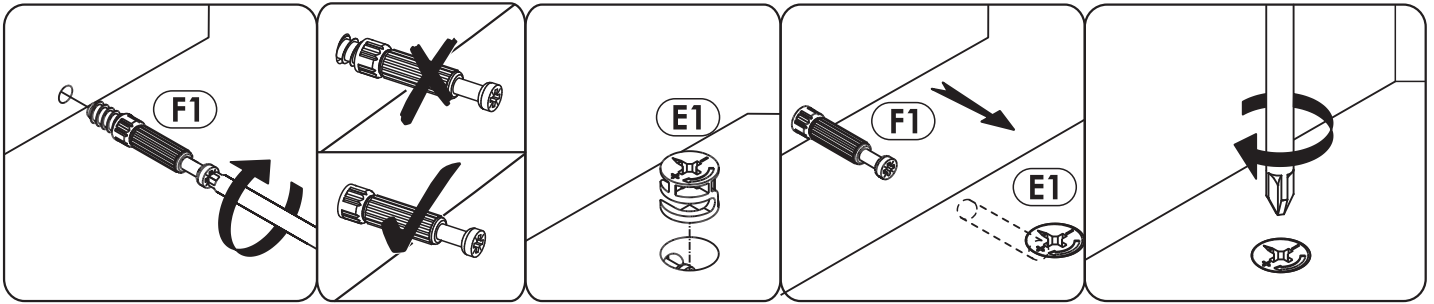

1 ▶

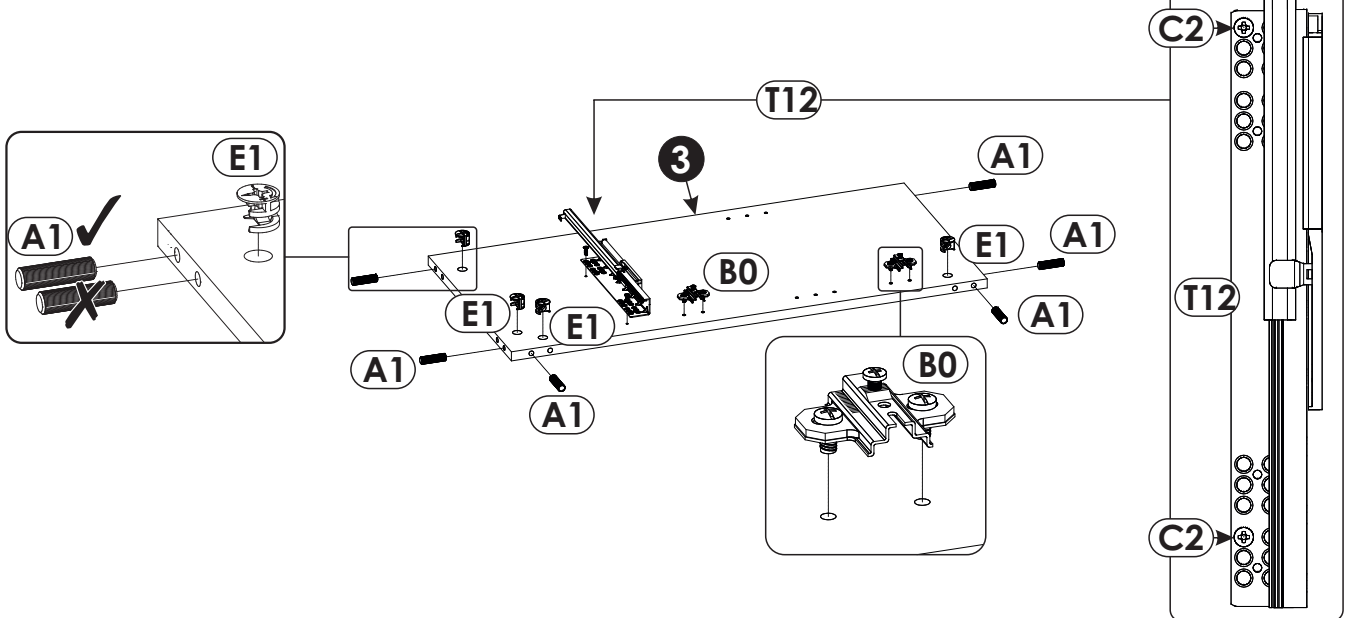
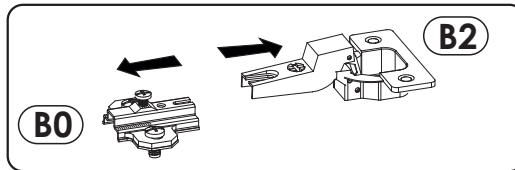
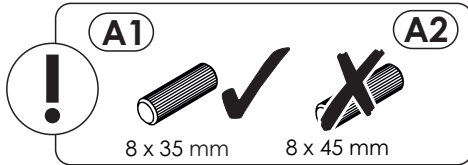
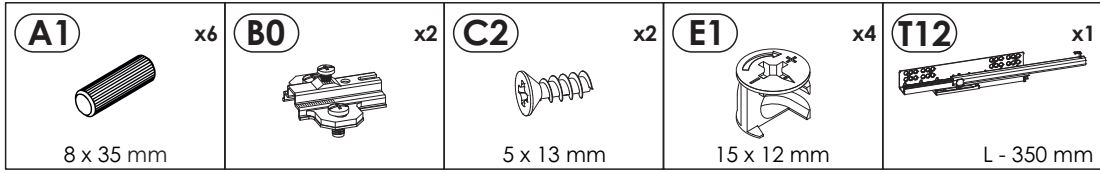

2 ▶

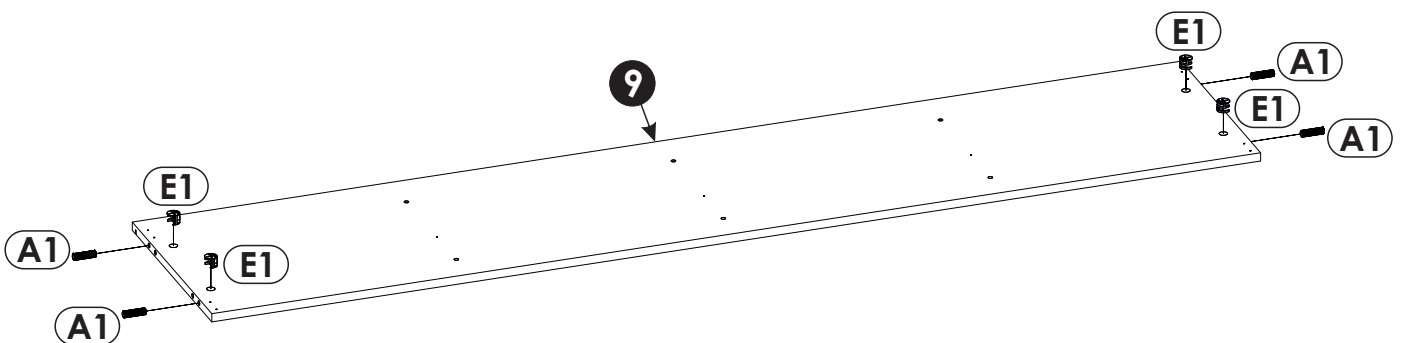
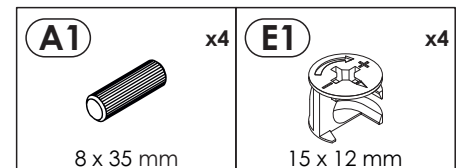
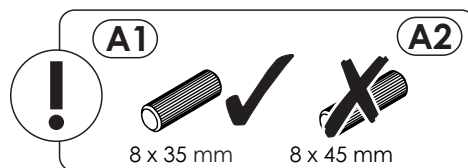

3 ▶

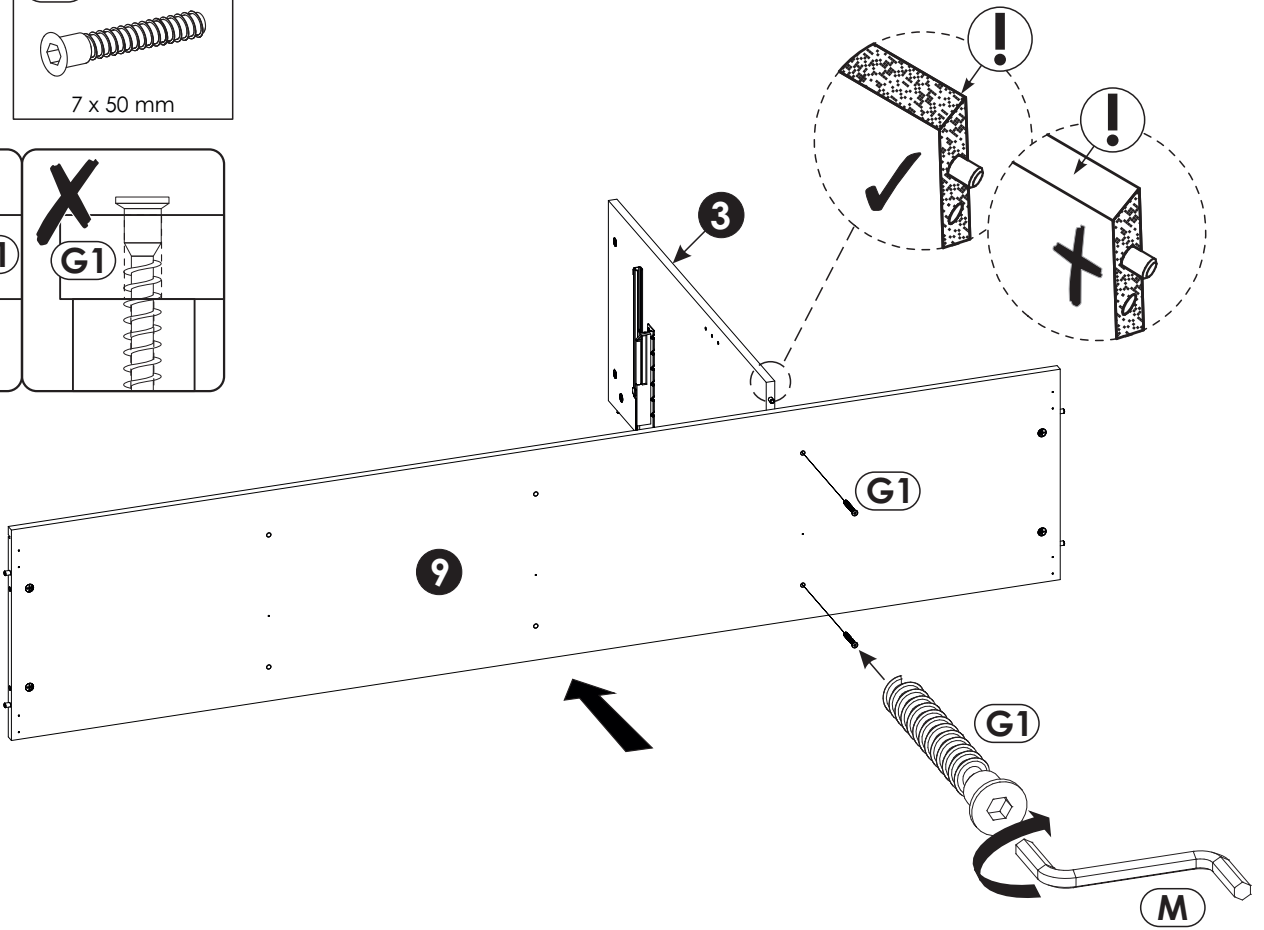
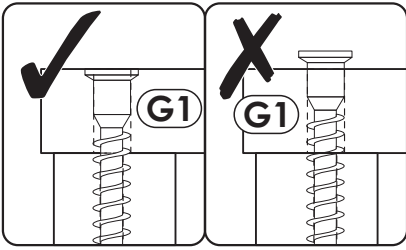
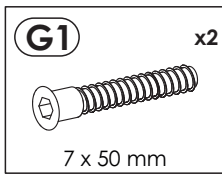

4 ▶

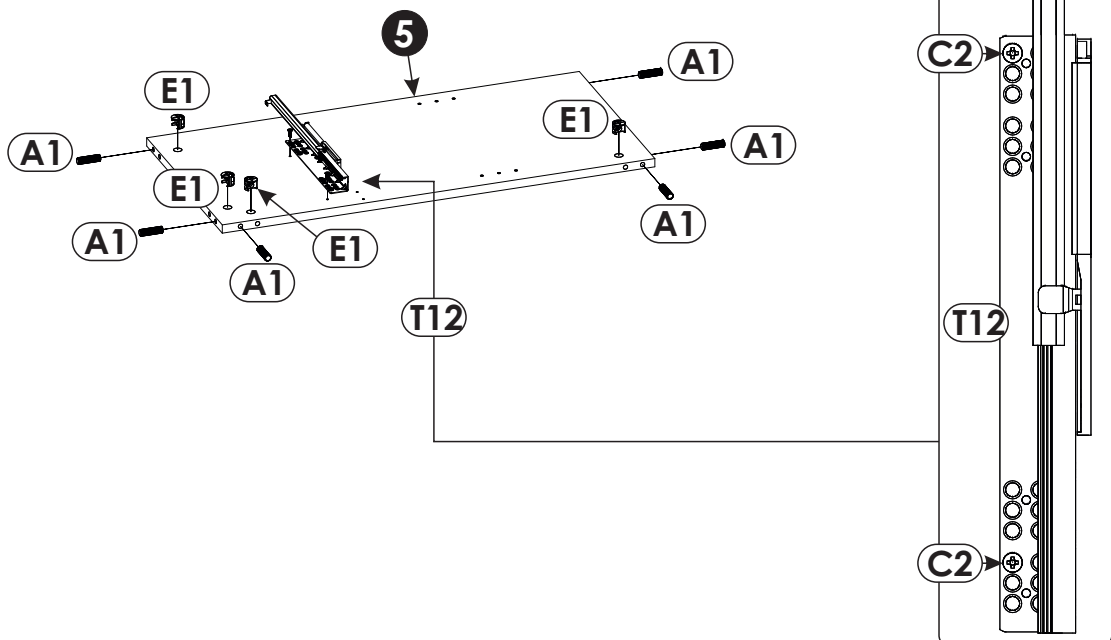
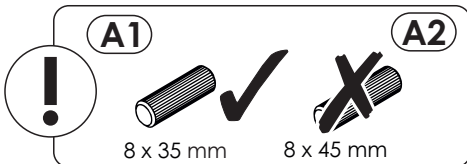
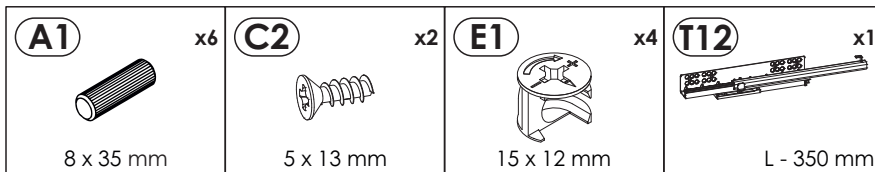

5 ▶

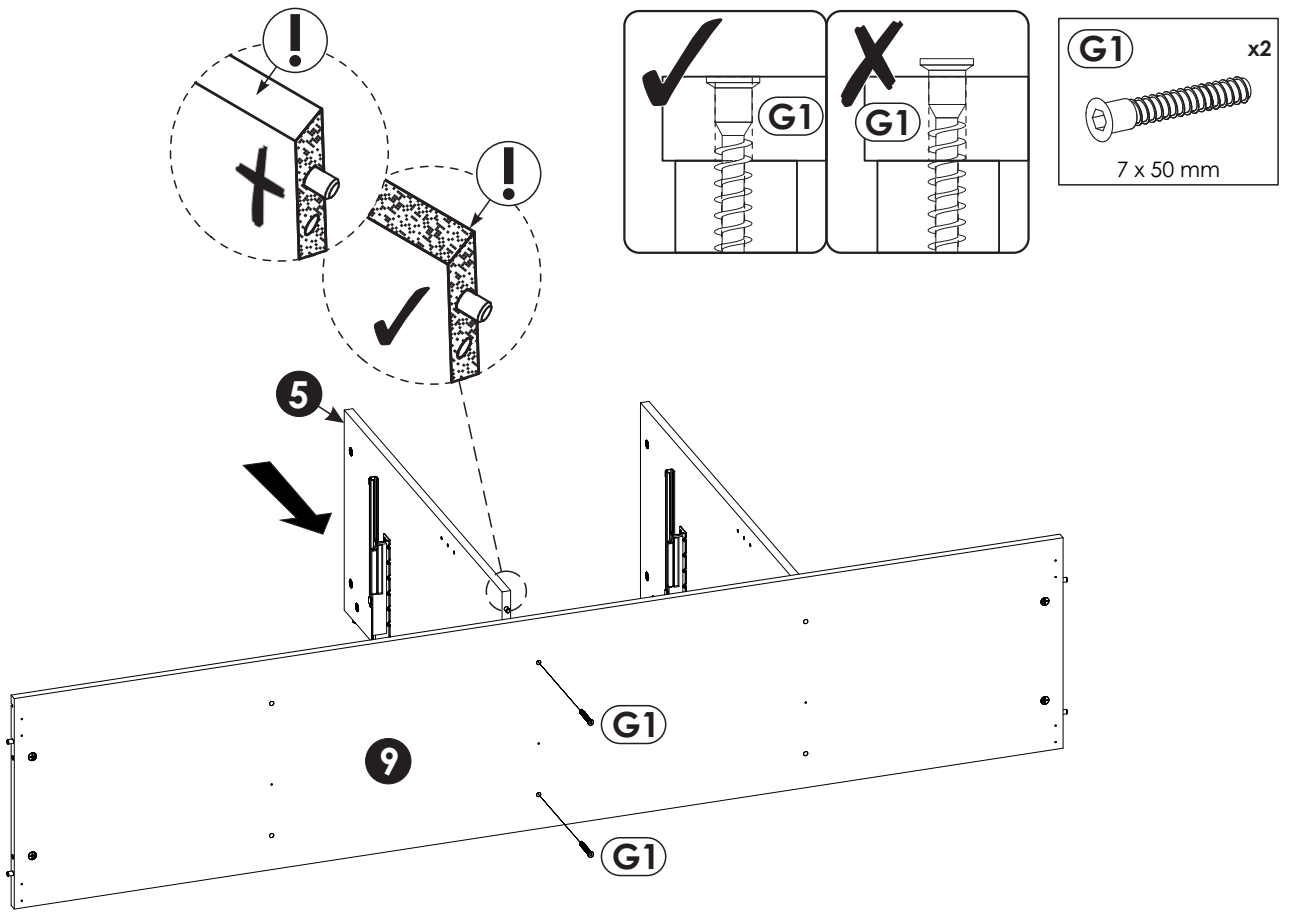

6 ▶

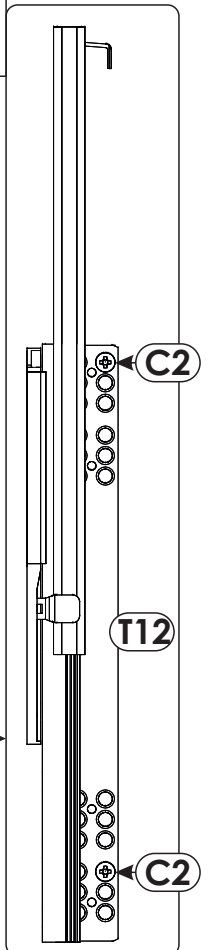
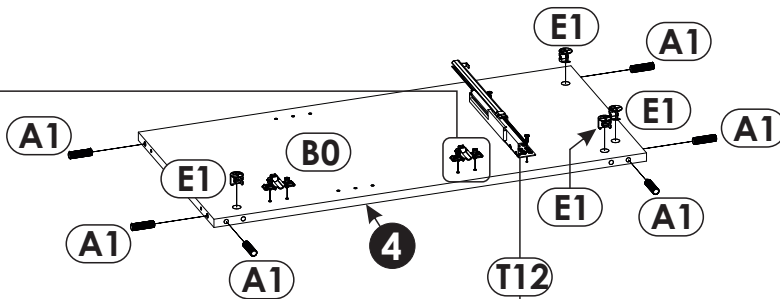
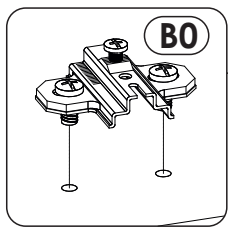
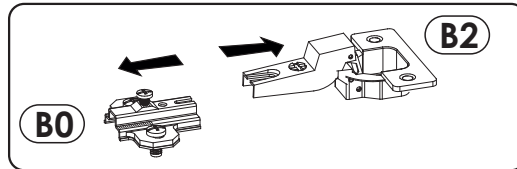
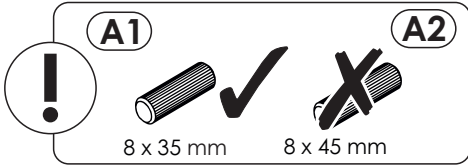
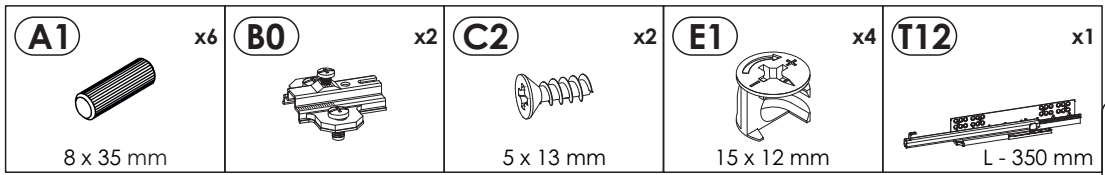

7 ▶

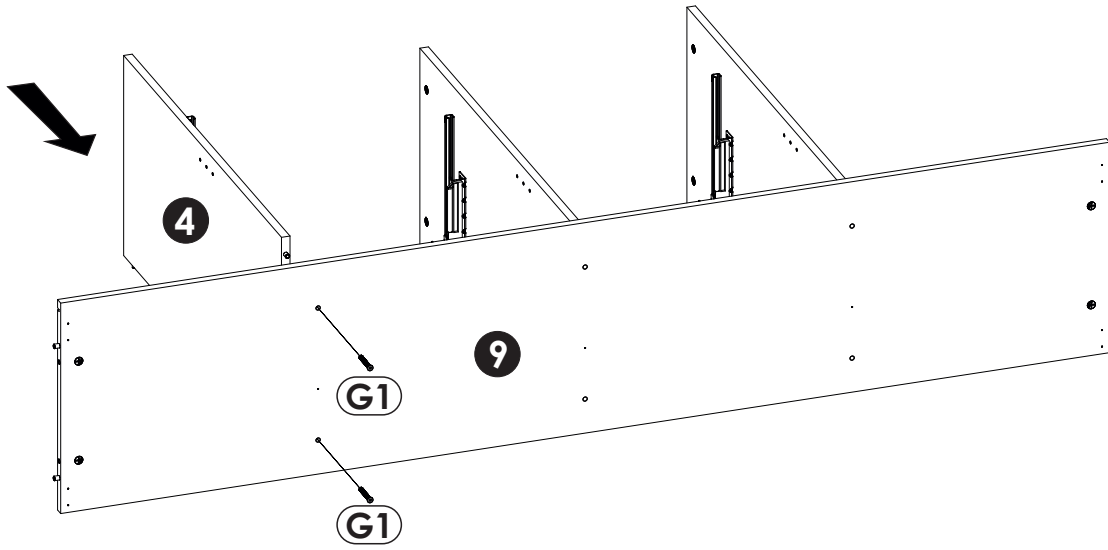
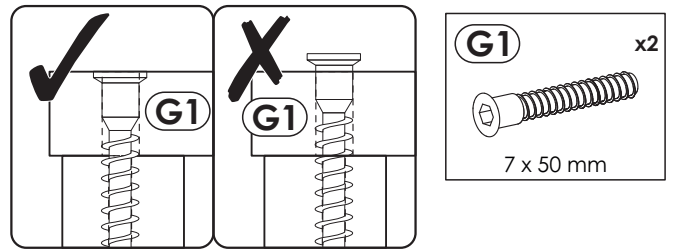

8 ▶

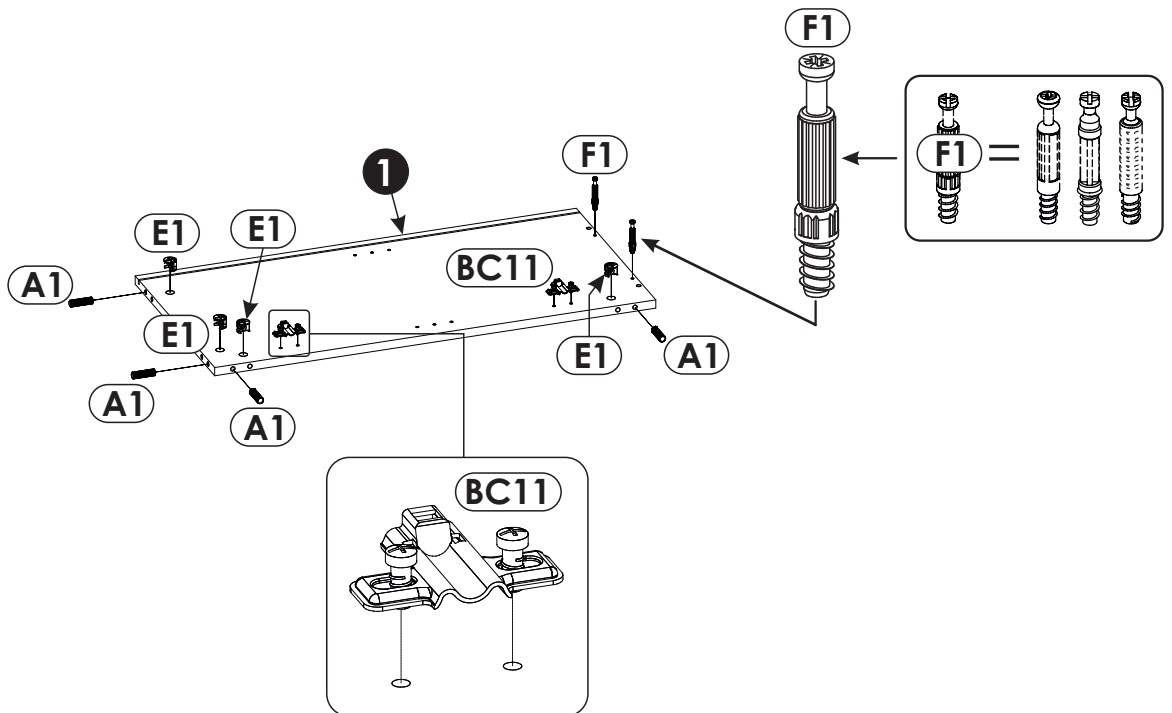
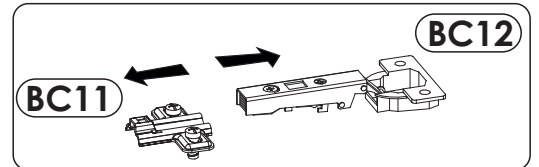
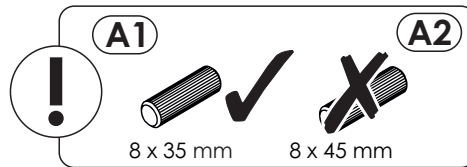
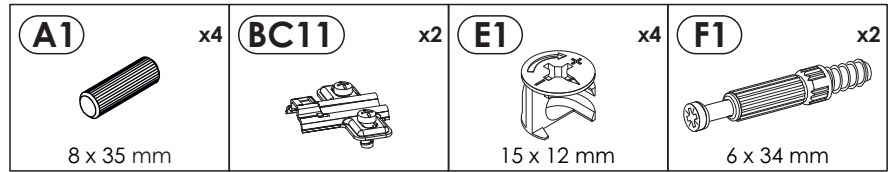

9 ▶

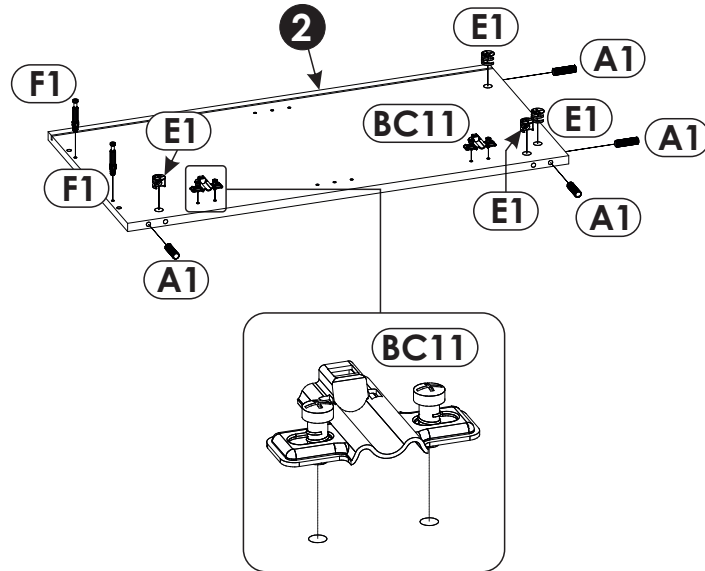
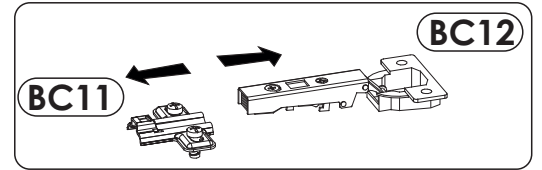
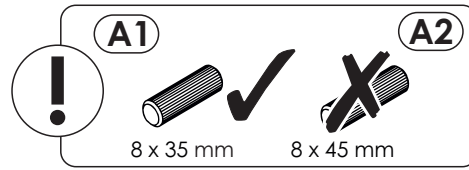
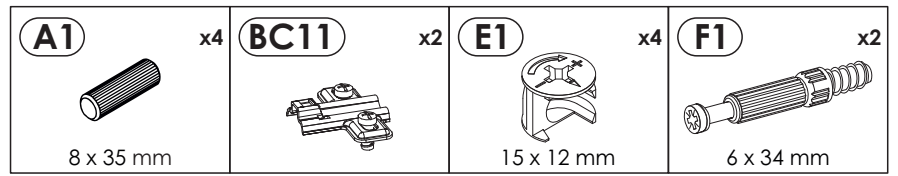

10 ▶

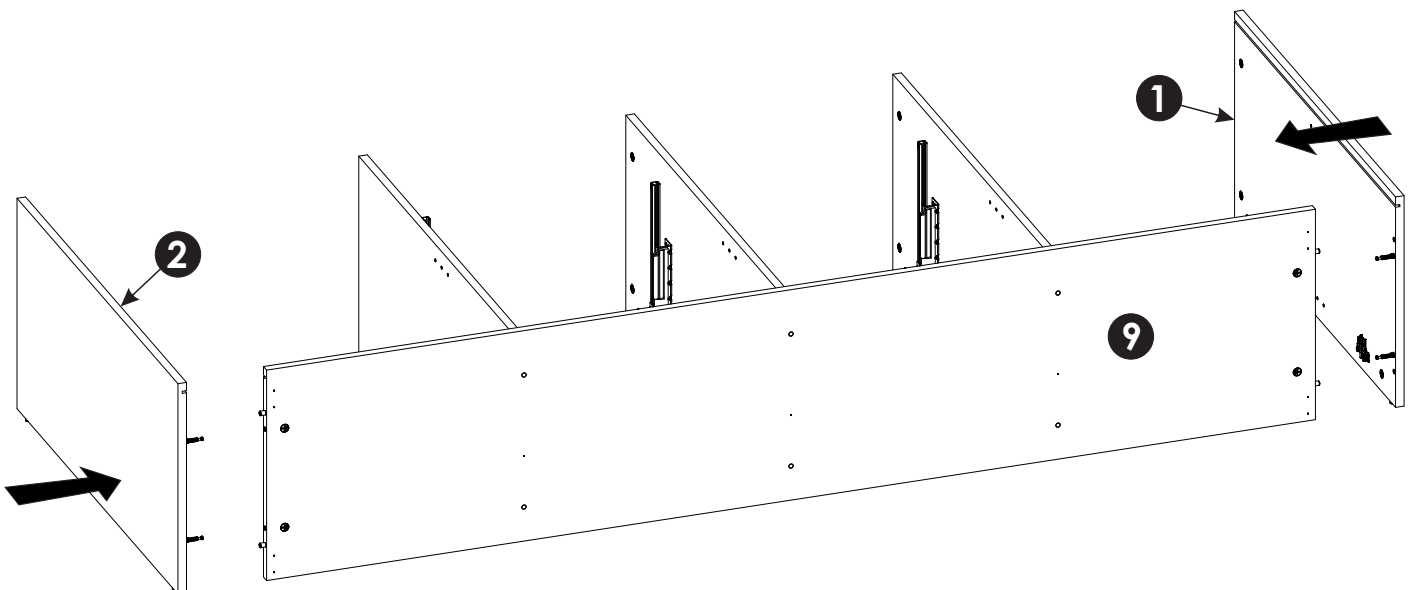
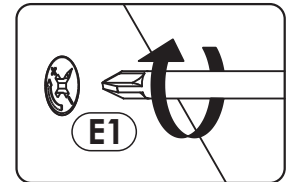

11 ▶

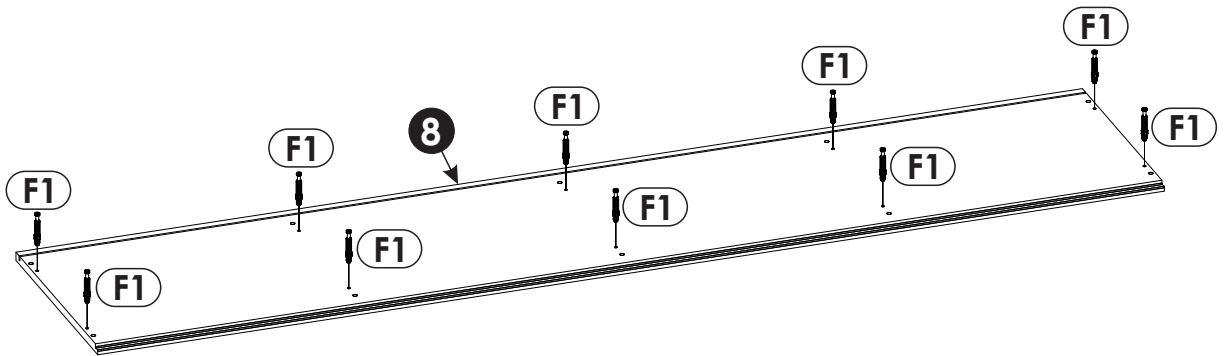
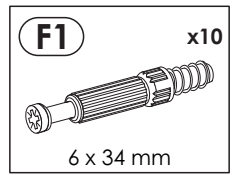

12 ▶

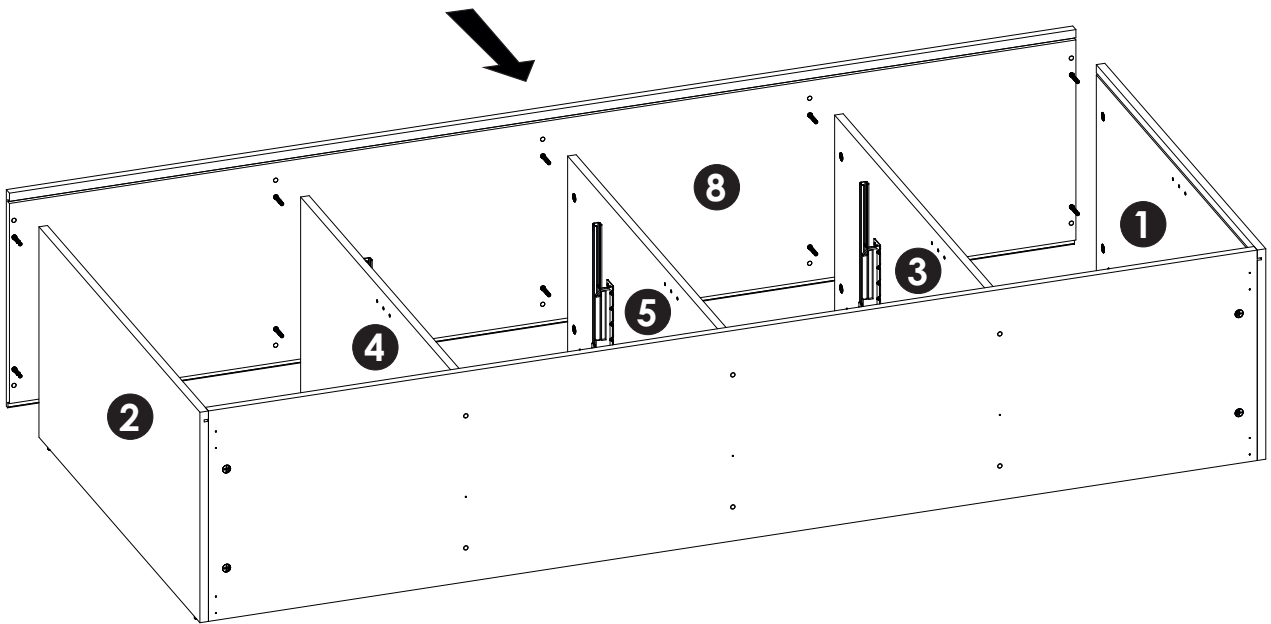
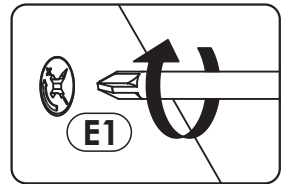
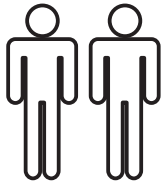

13 ▶

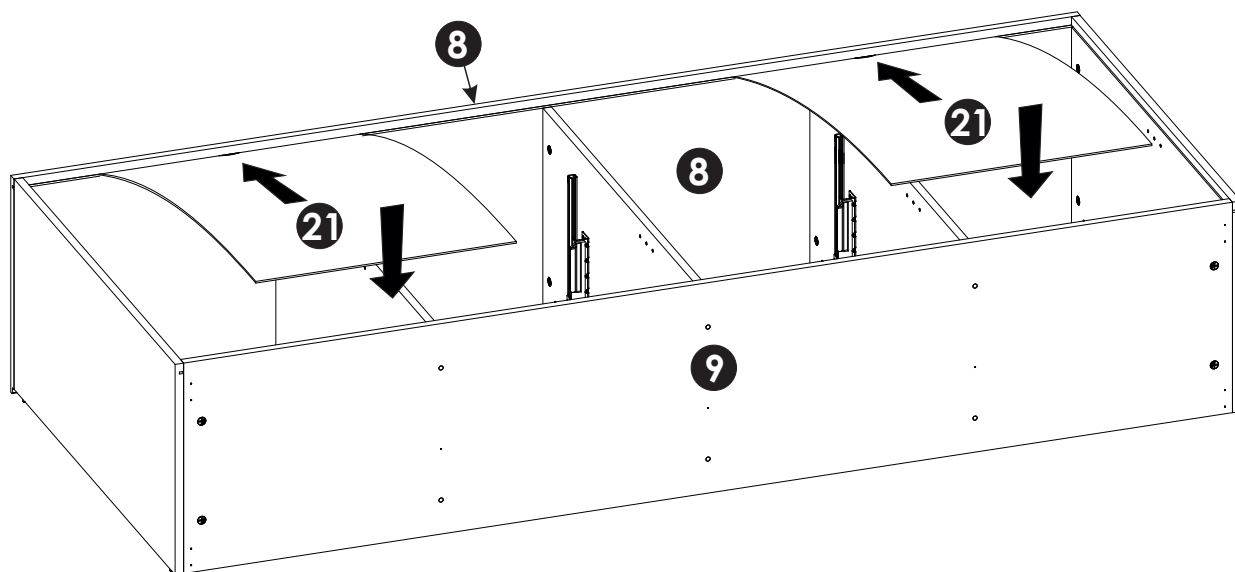

14 ▶

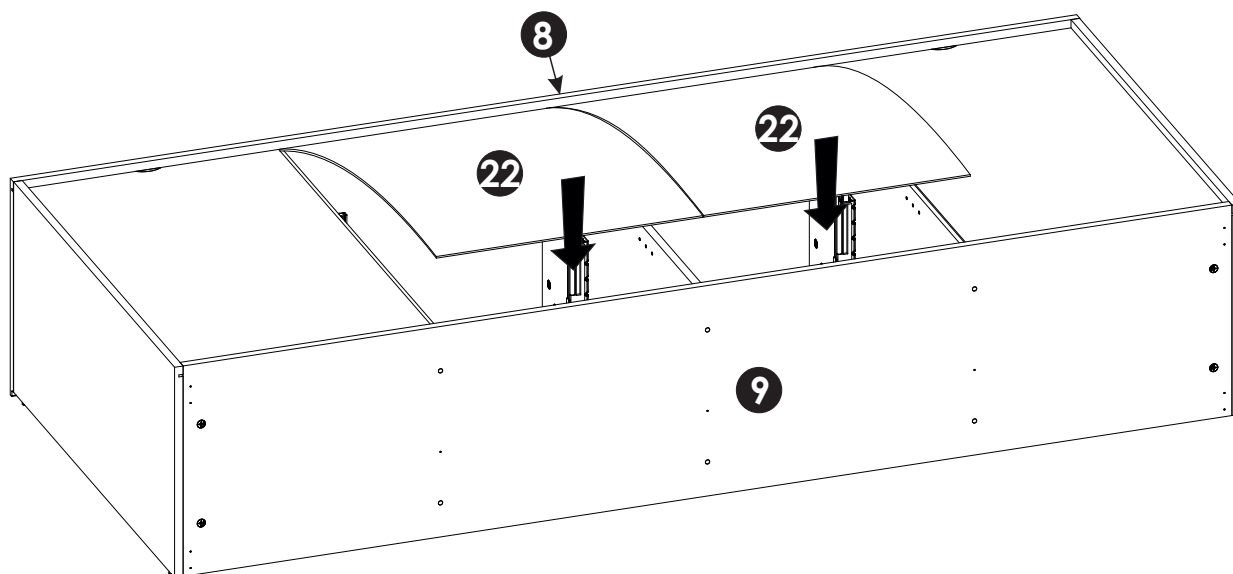

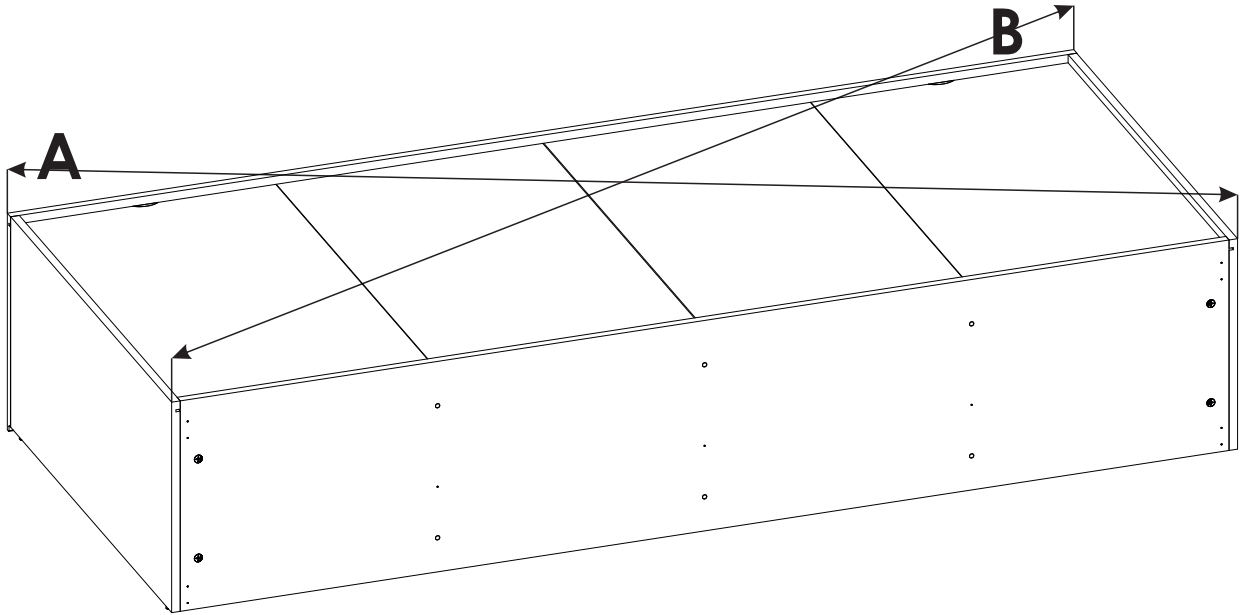
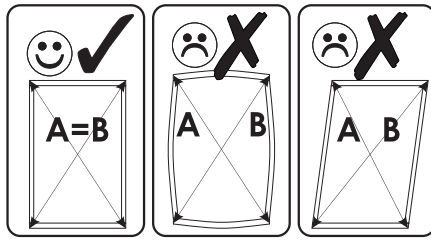

15 ▶

A=B

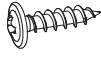

16 ▶

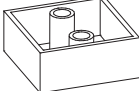
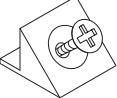
I2 x15  4 x 16 mm	I4 x11  3,5 x 27 mm	O1 x3 	O6 x4 	R4 x12 
---	---	--	---	--

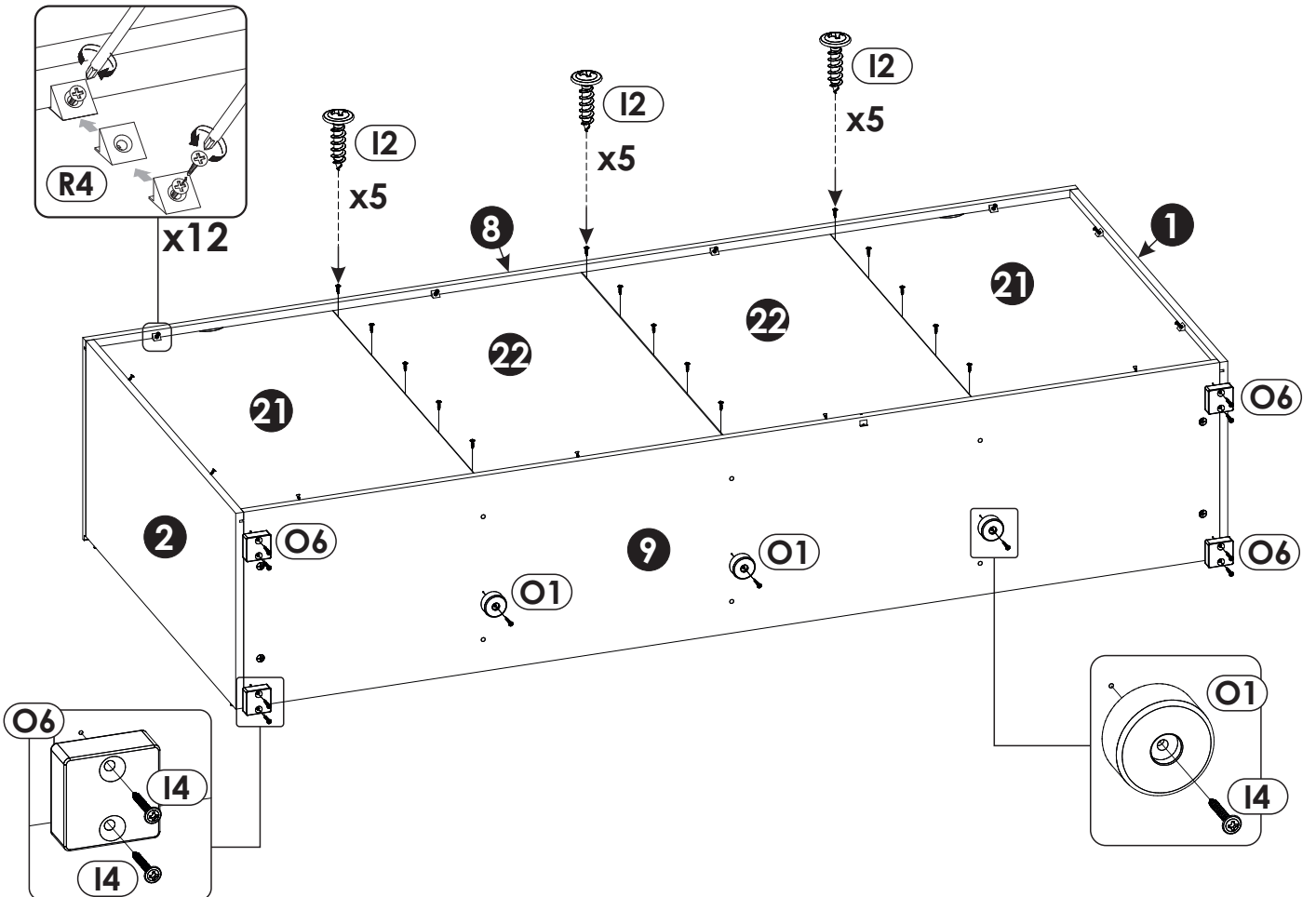

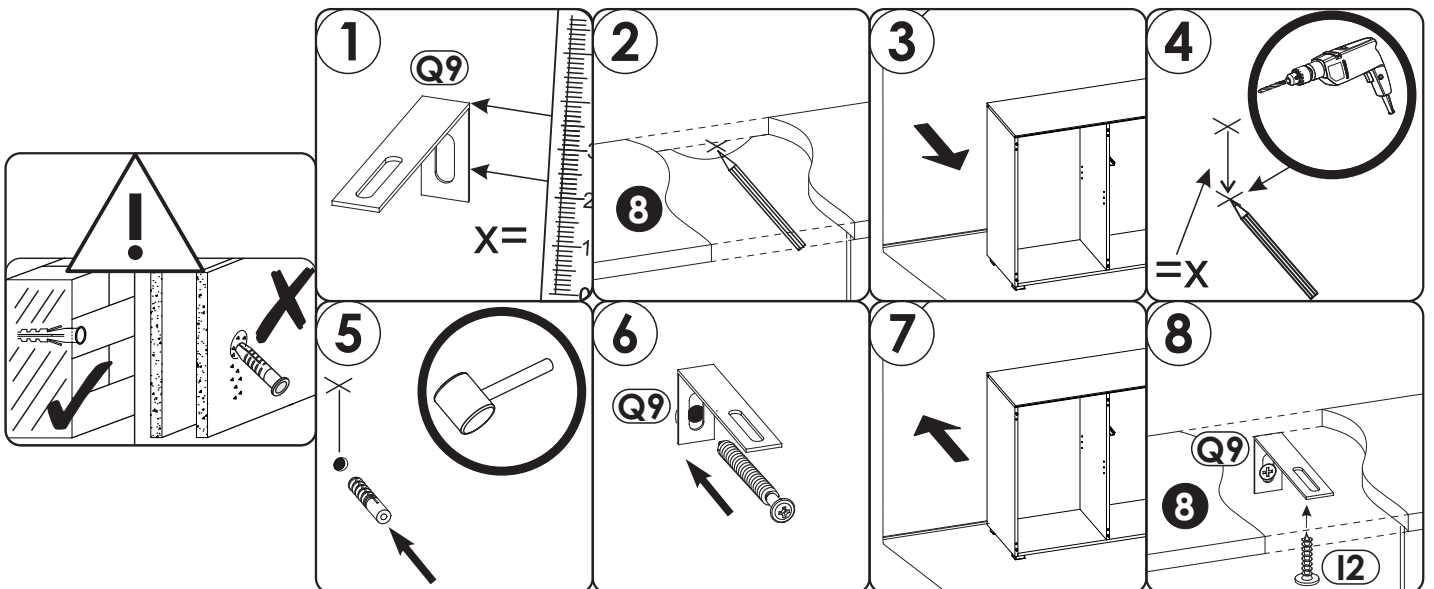
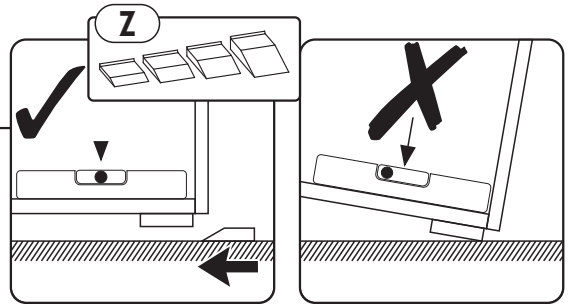
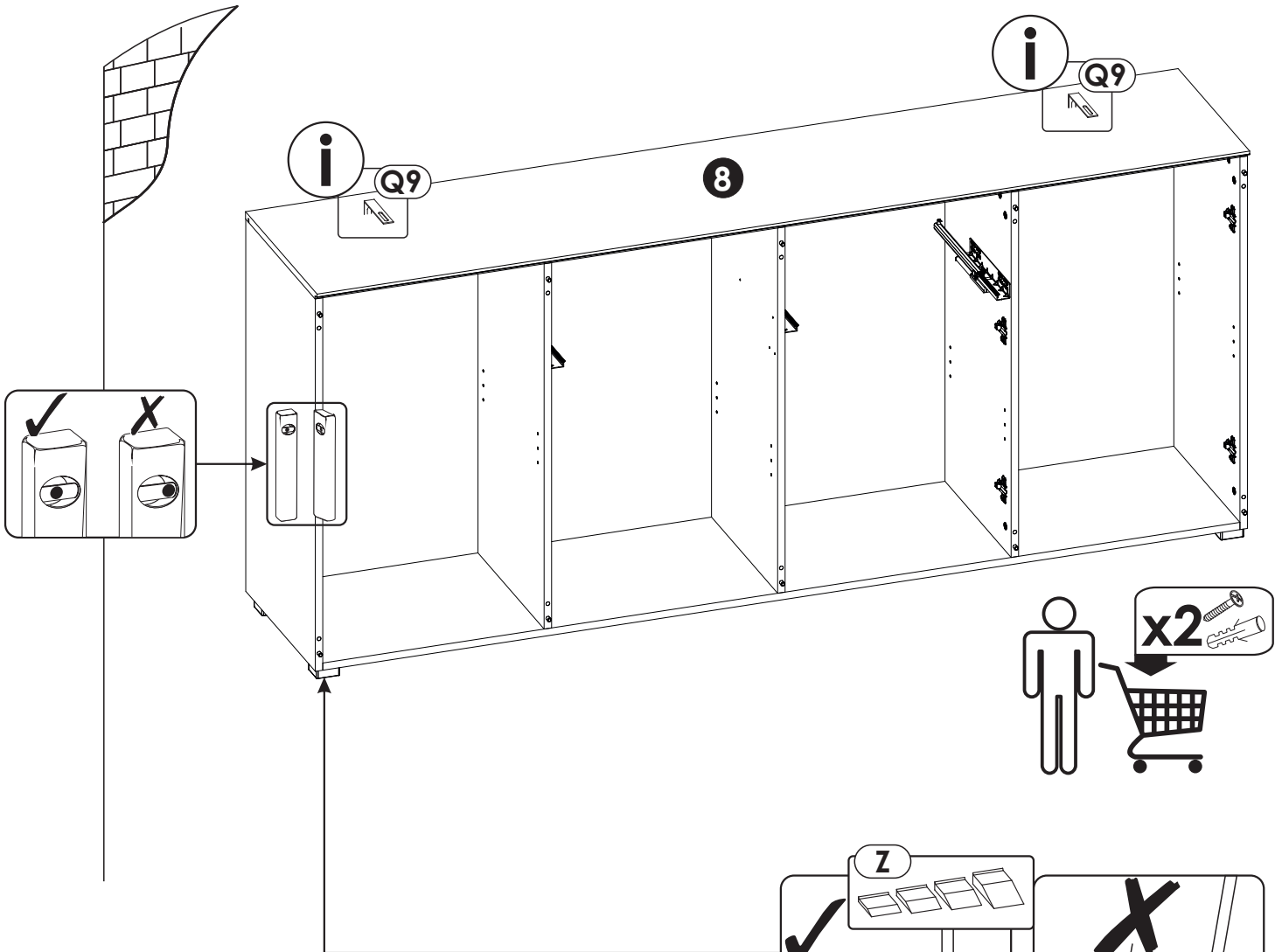
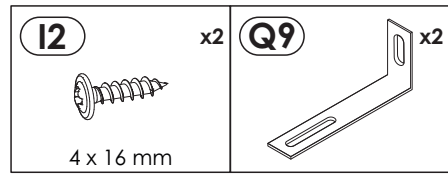

18 ▶

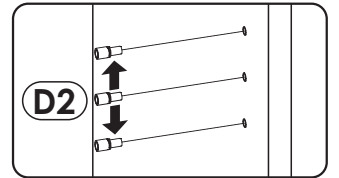
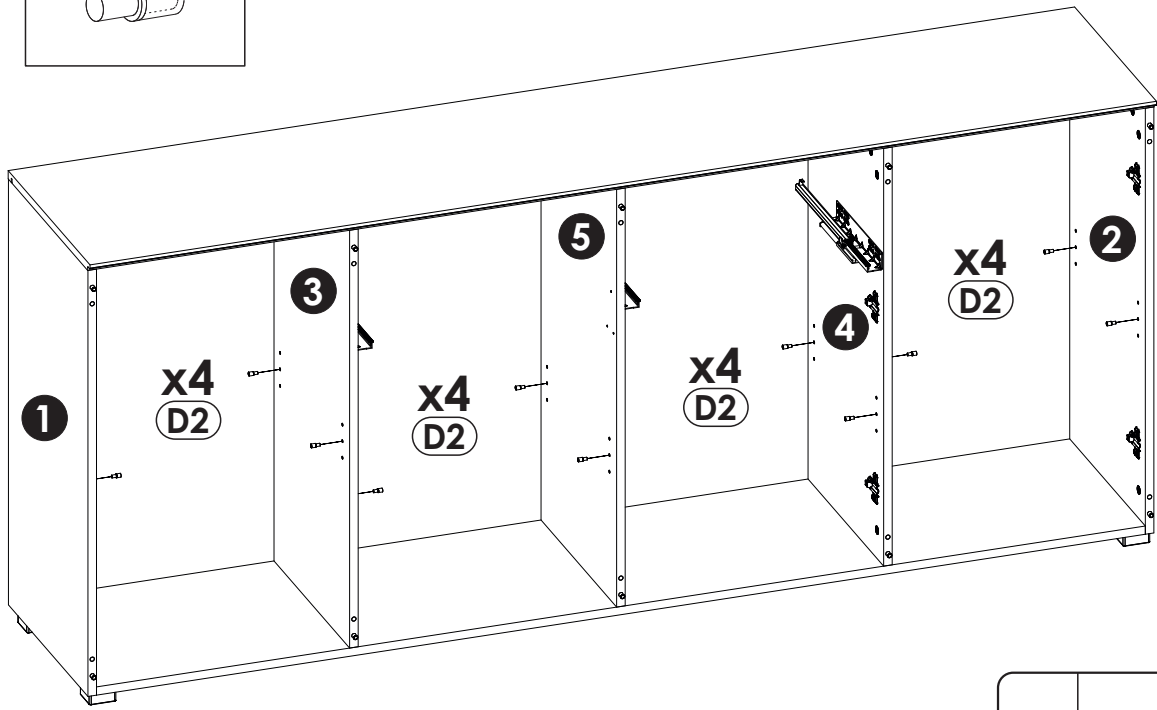
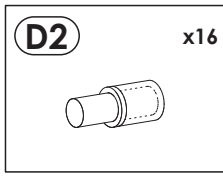

19 ▶

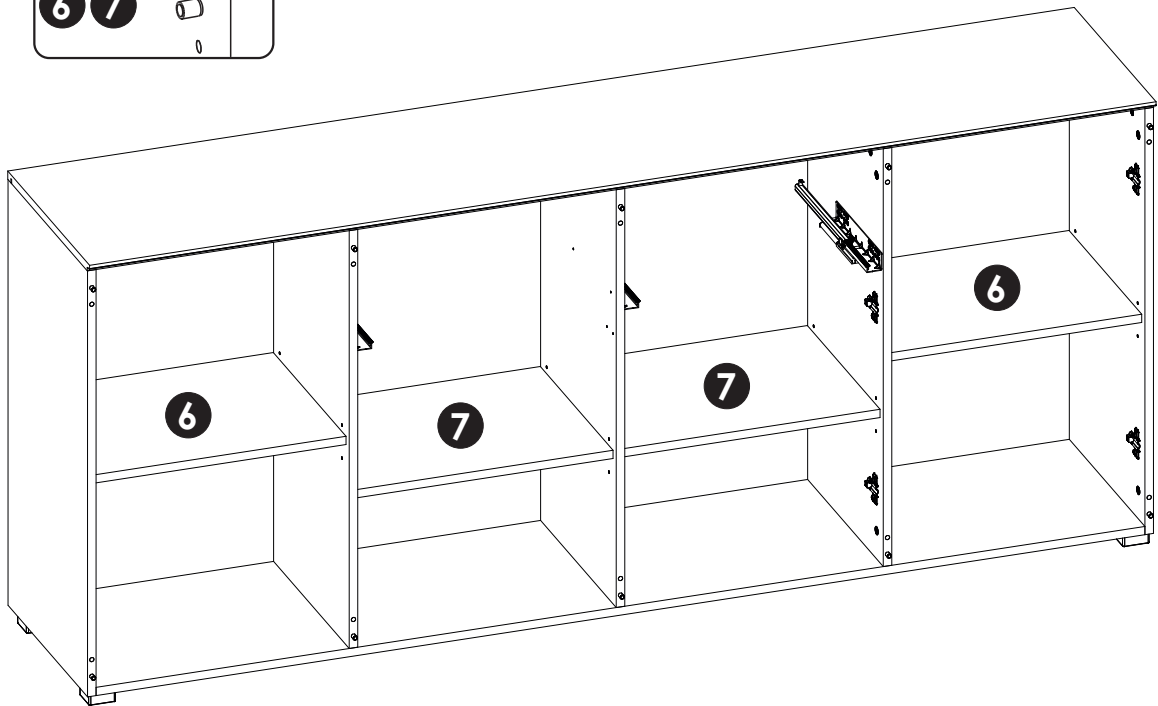
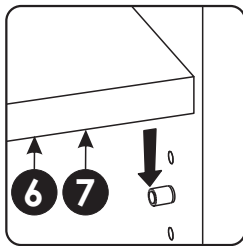

20 ▶

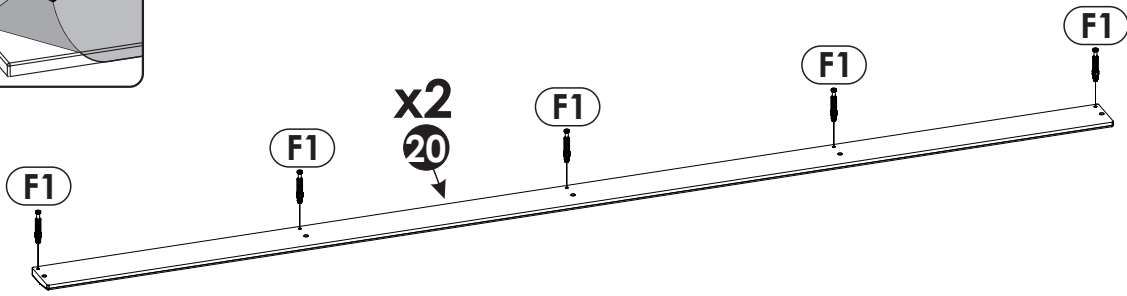
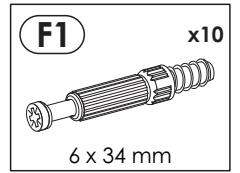
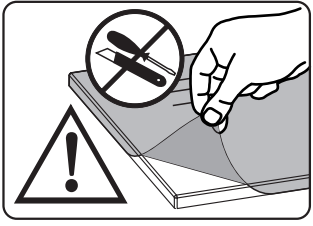

21 ▶

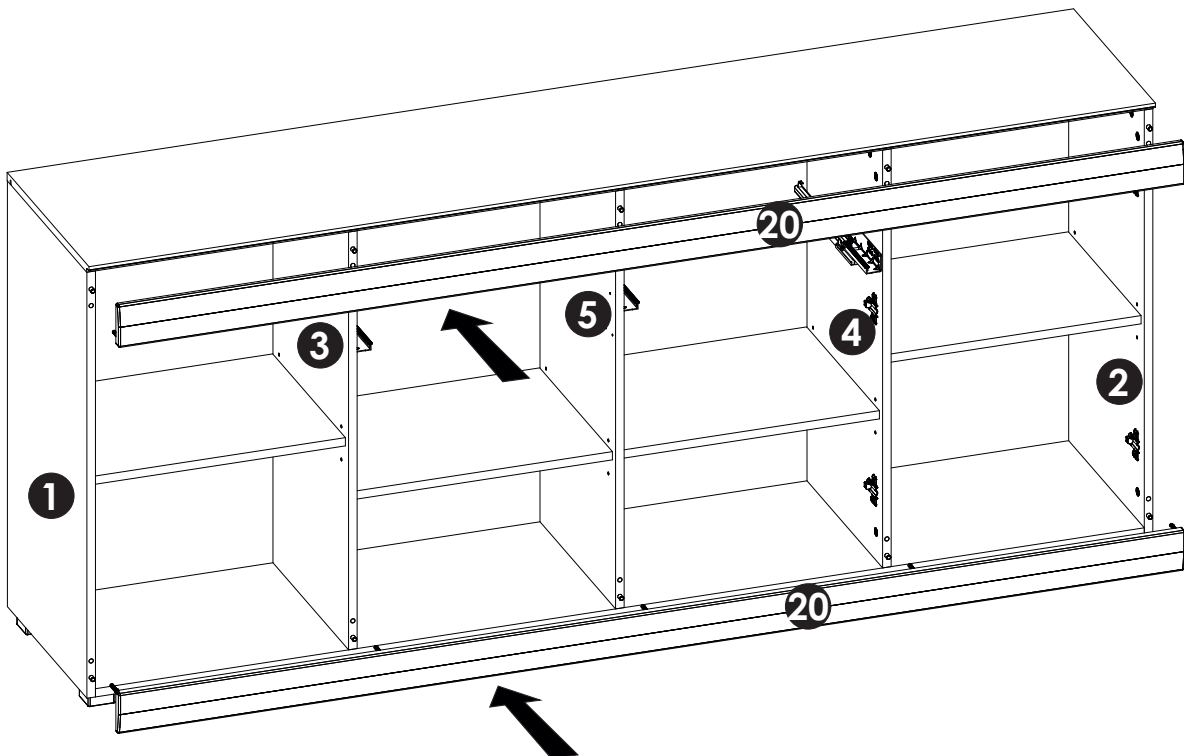
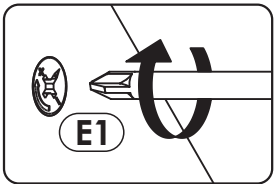



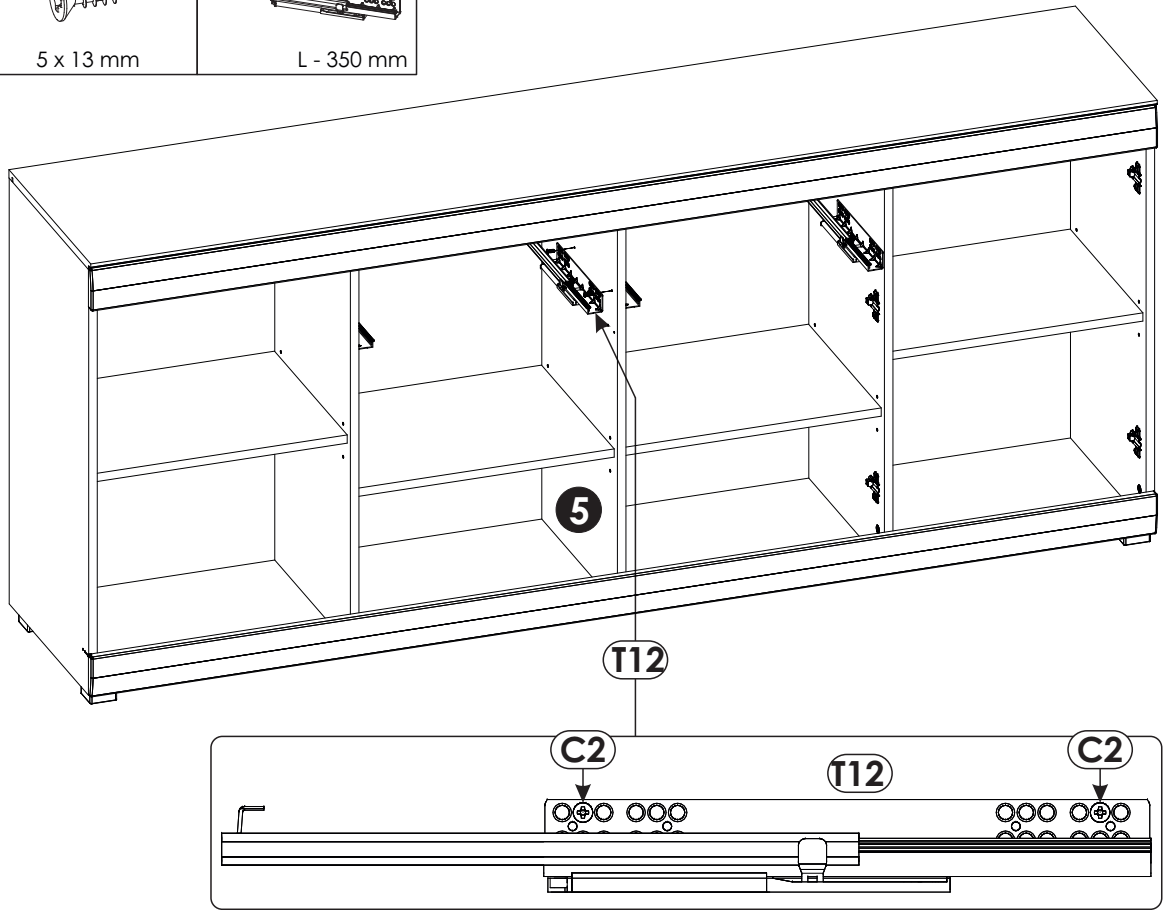
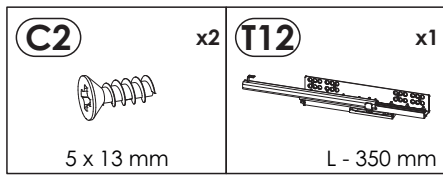

22 ▶

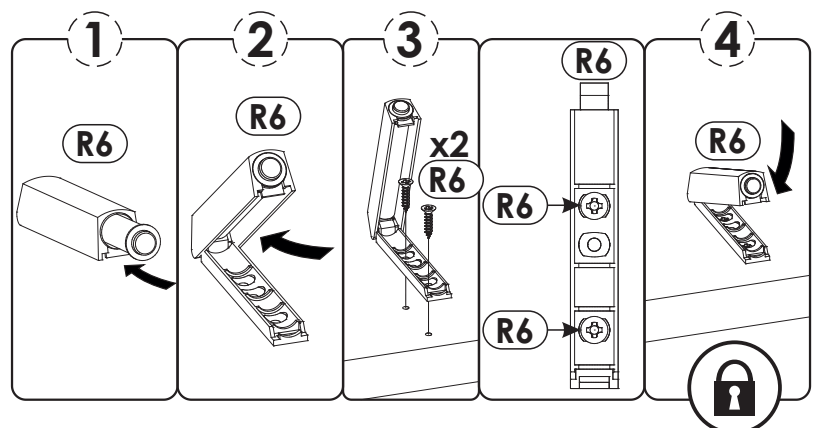
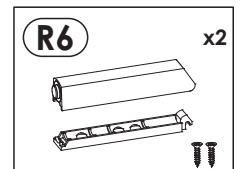
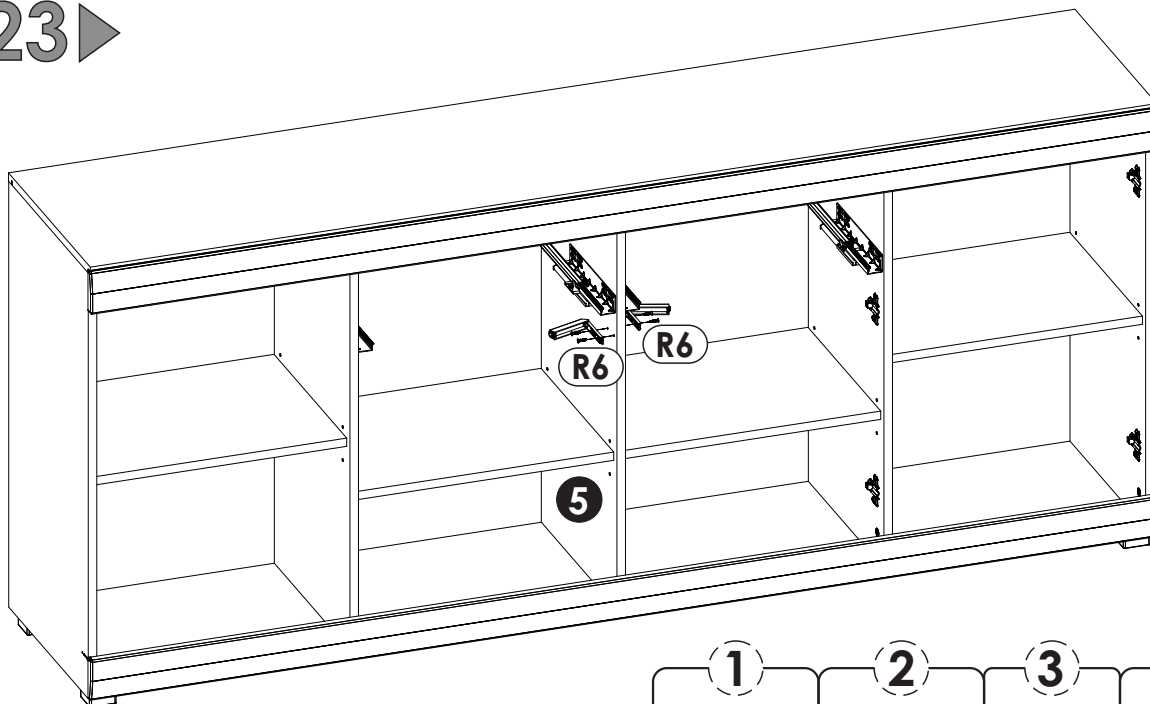

23 ▶

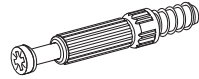

24▶

A1	x16	E1	x4	F1	x4	R8	x4
							
8 x 35 mm		15 x 12 mm		6 x 34 mm			

x2

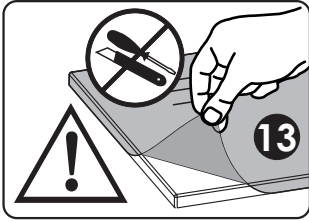
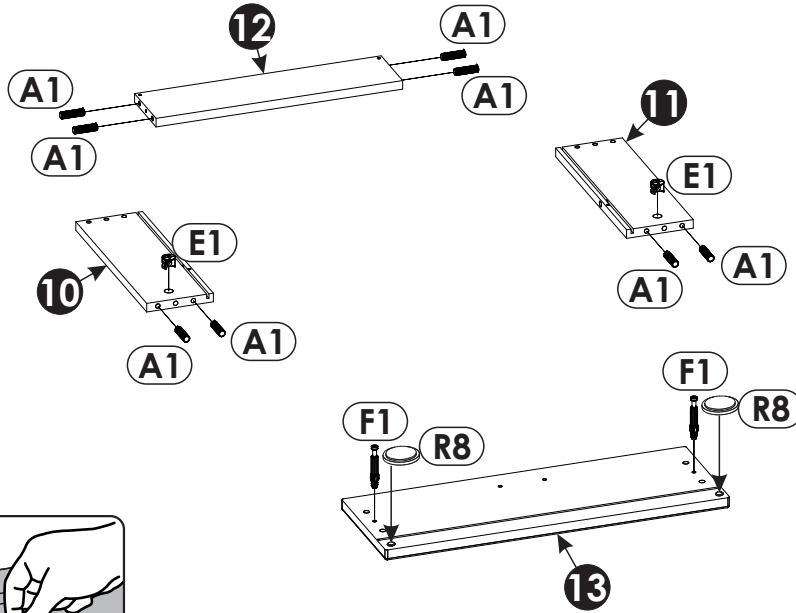

25▶

G1	x4
	
7 x 50 mm	

x2

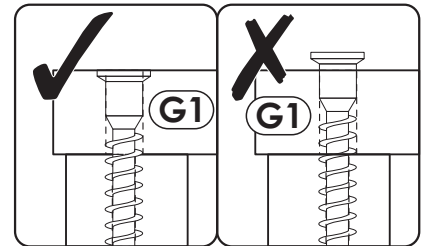
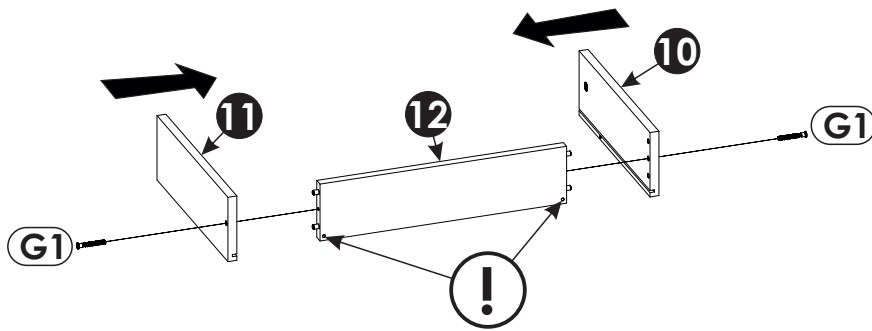

26 ▶

x2

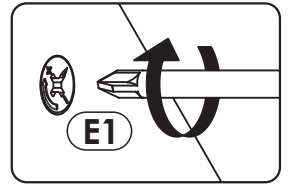
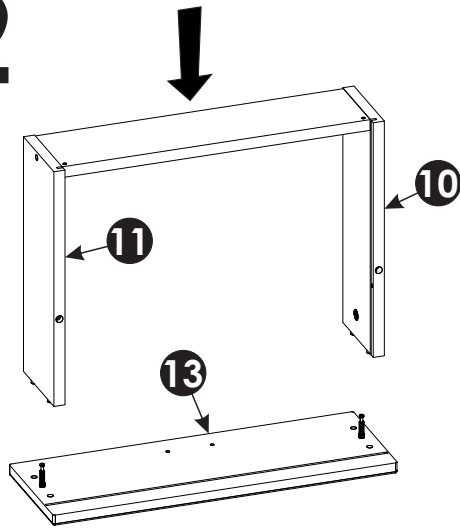

27 ▶

x2

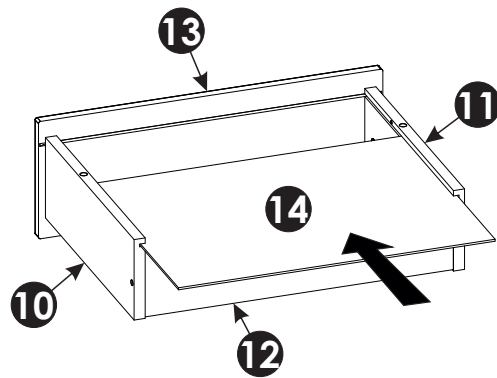

28 ▶

x2

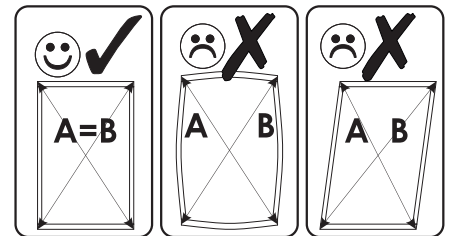
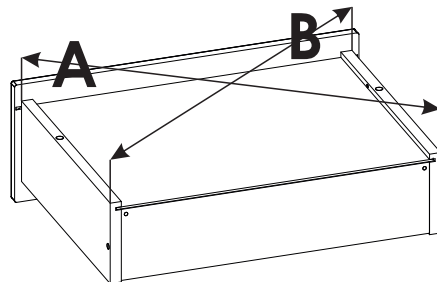

A=B

29 ▶

x2

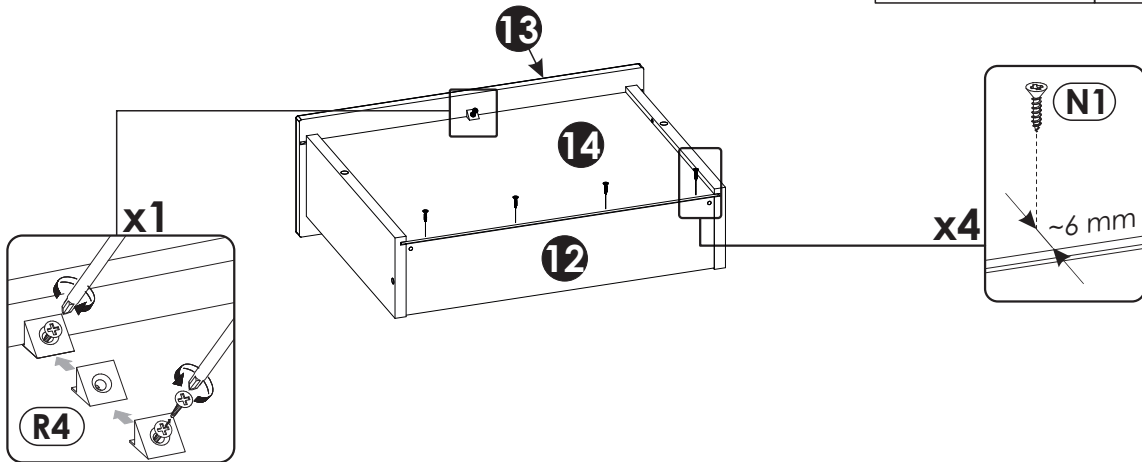
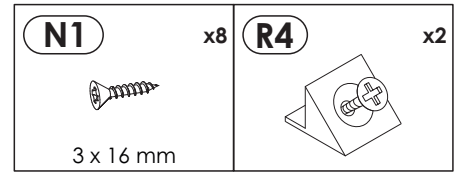

30 ▶

x2

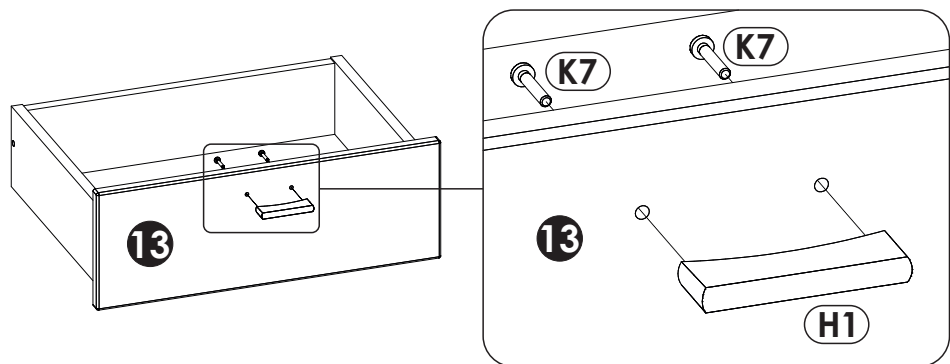
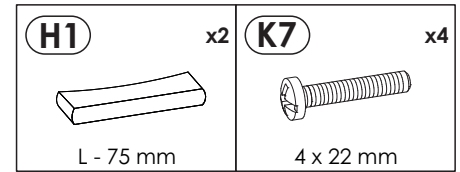

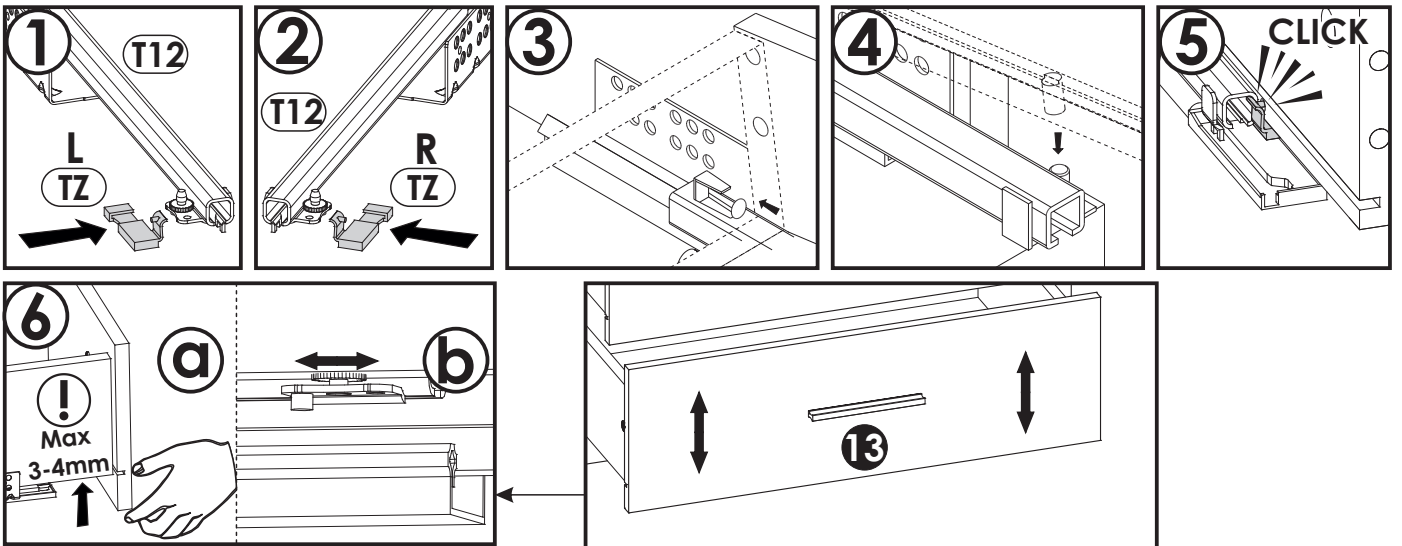
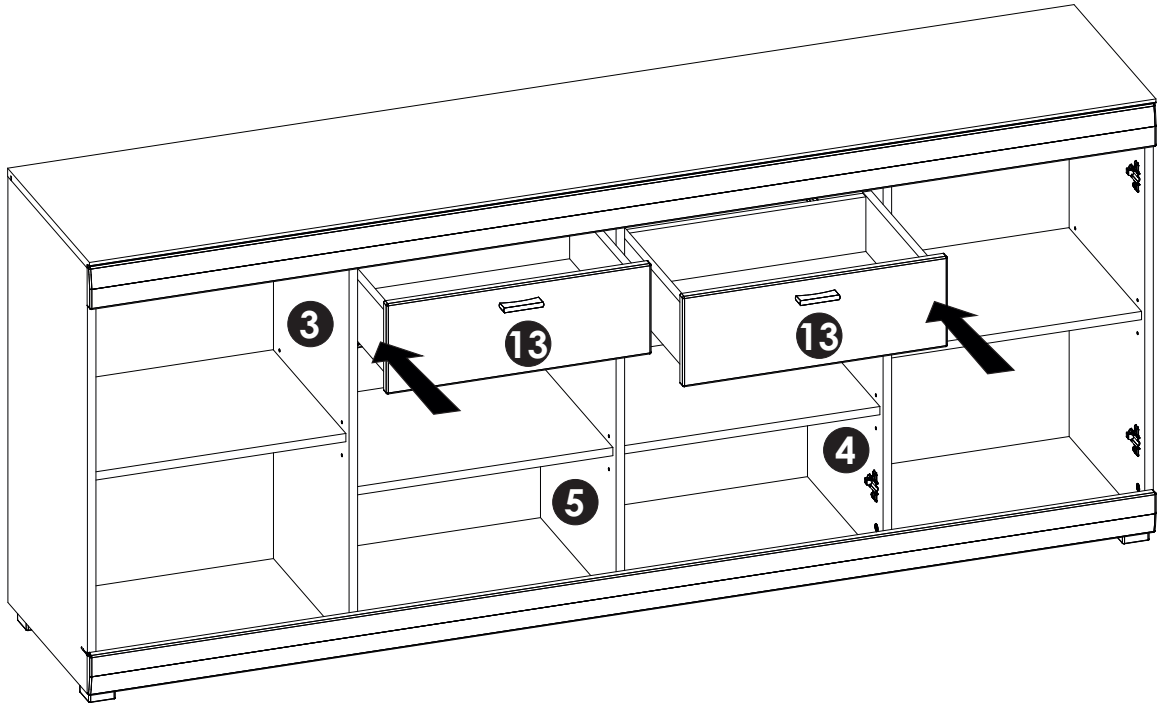

32 ▶

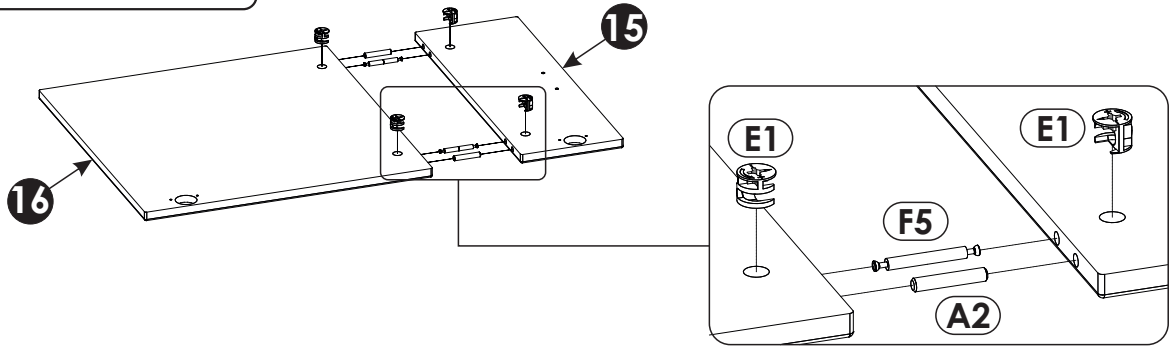
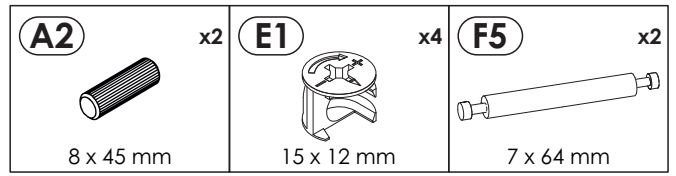
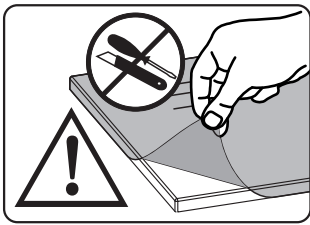

33 ▶

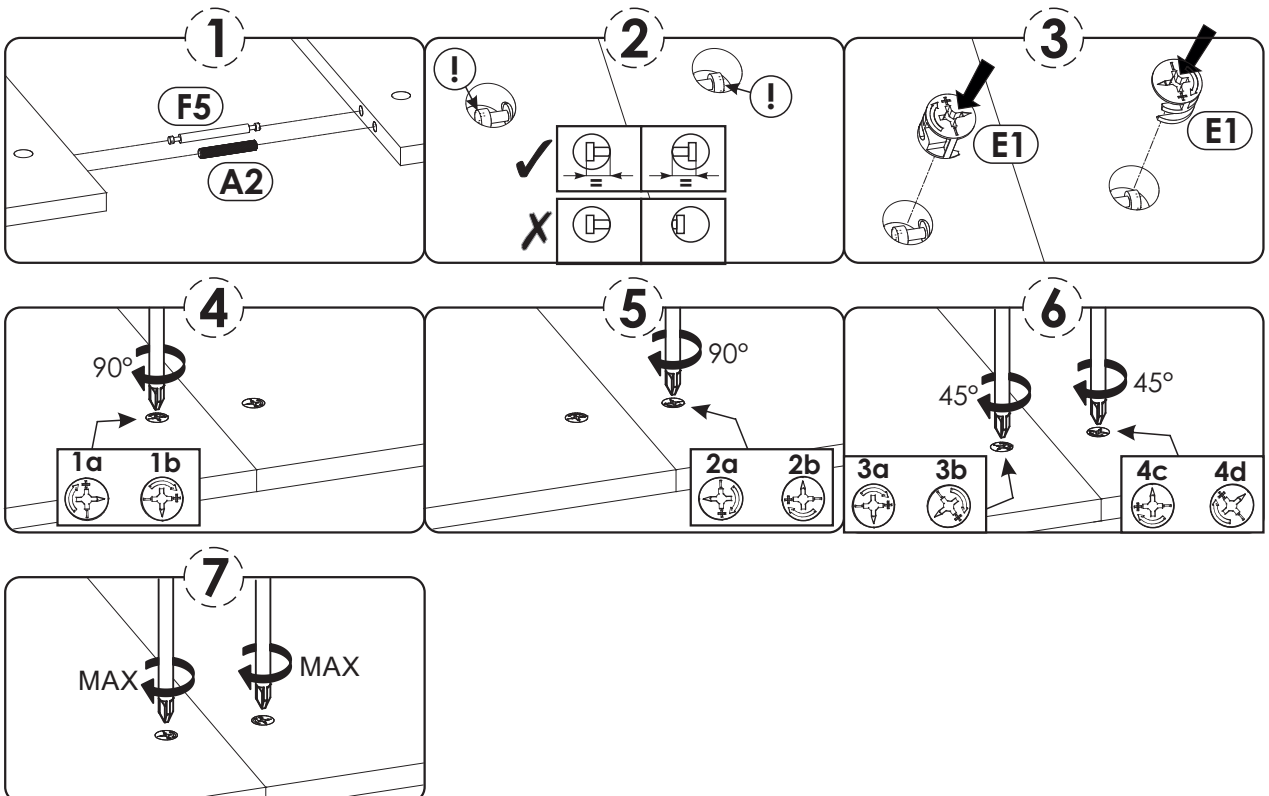
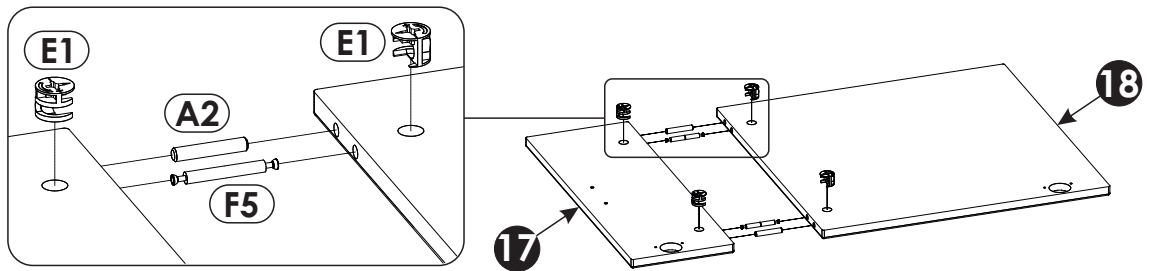
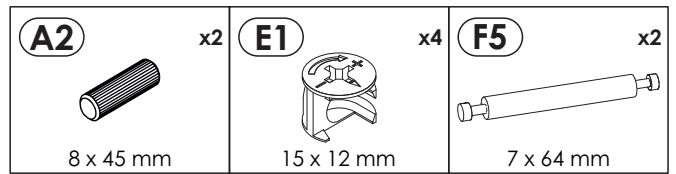
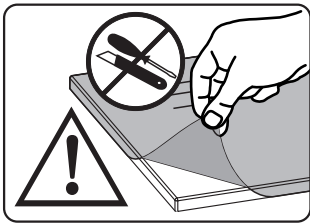

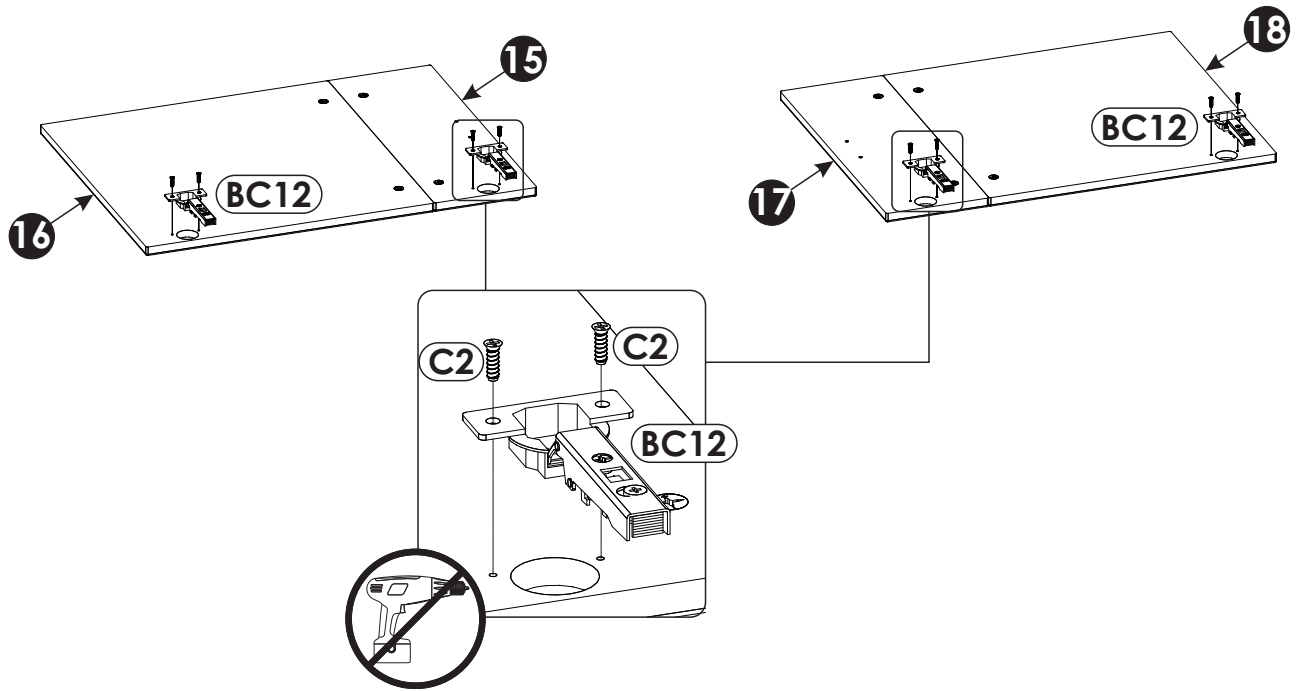
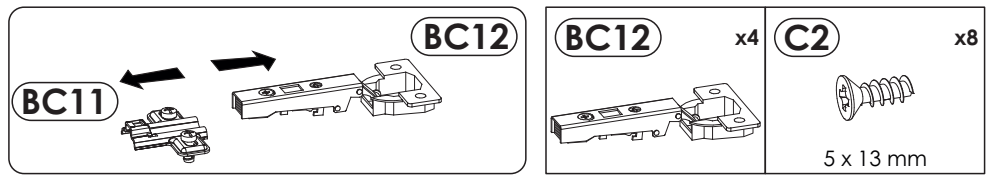

34 ▶

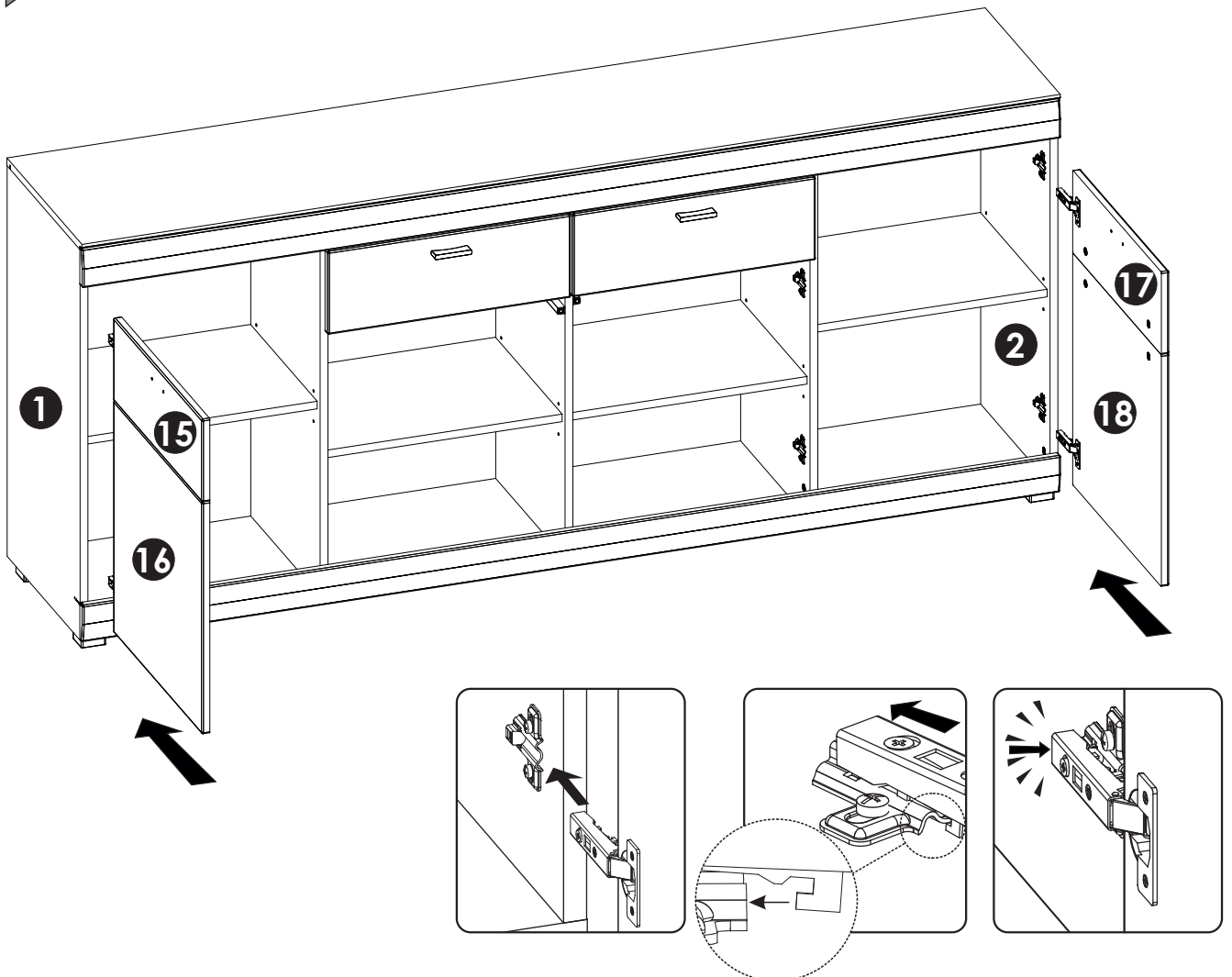

35 ▶



36 ▶

B2	x4	C2	x8	R8	x4
			5 x 13 mm		

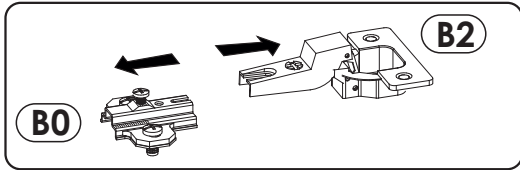
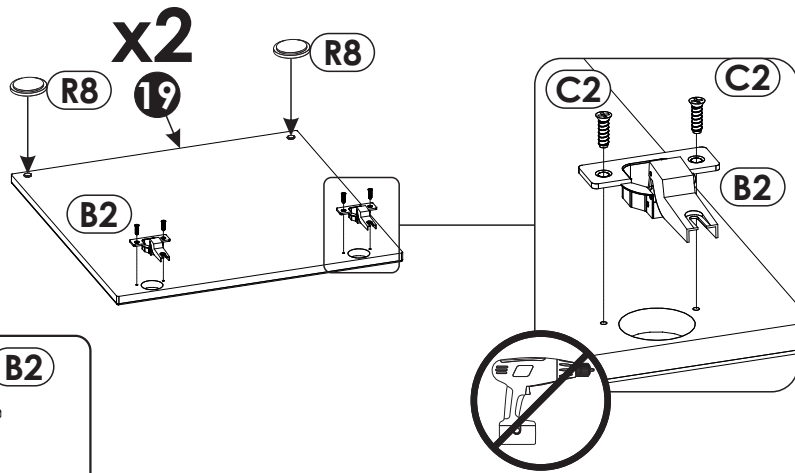
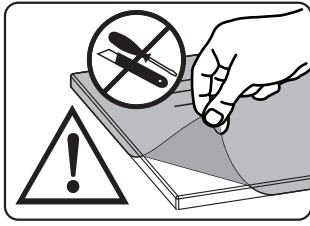

37 ▶

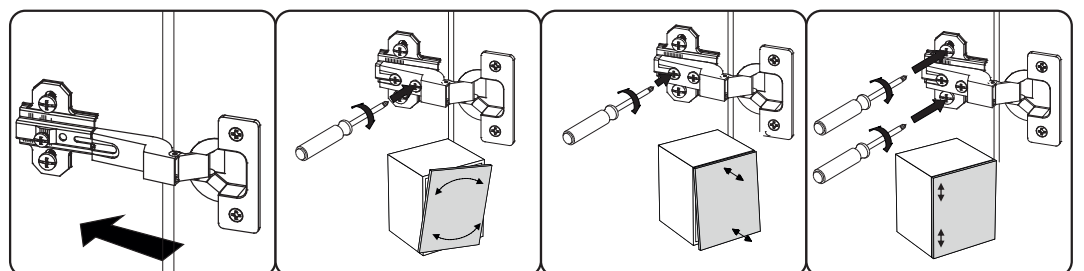
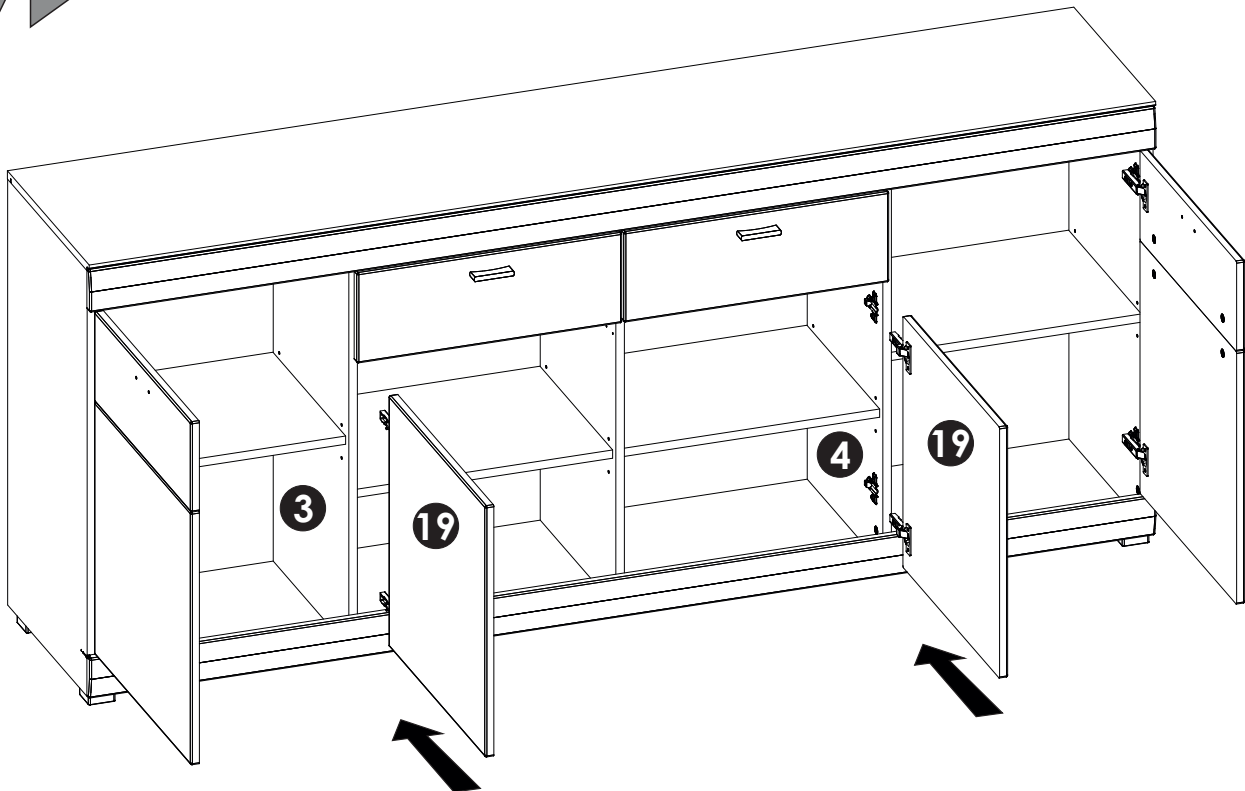

38 ▶

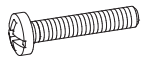
H1	x2	K7	x4
			
L - 75 mm		4 x 22 mm	

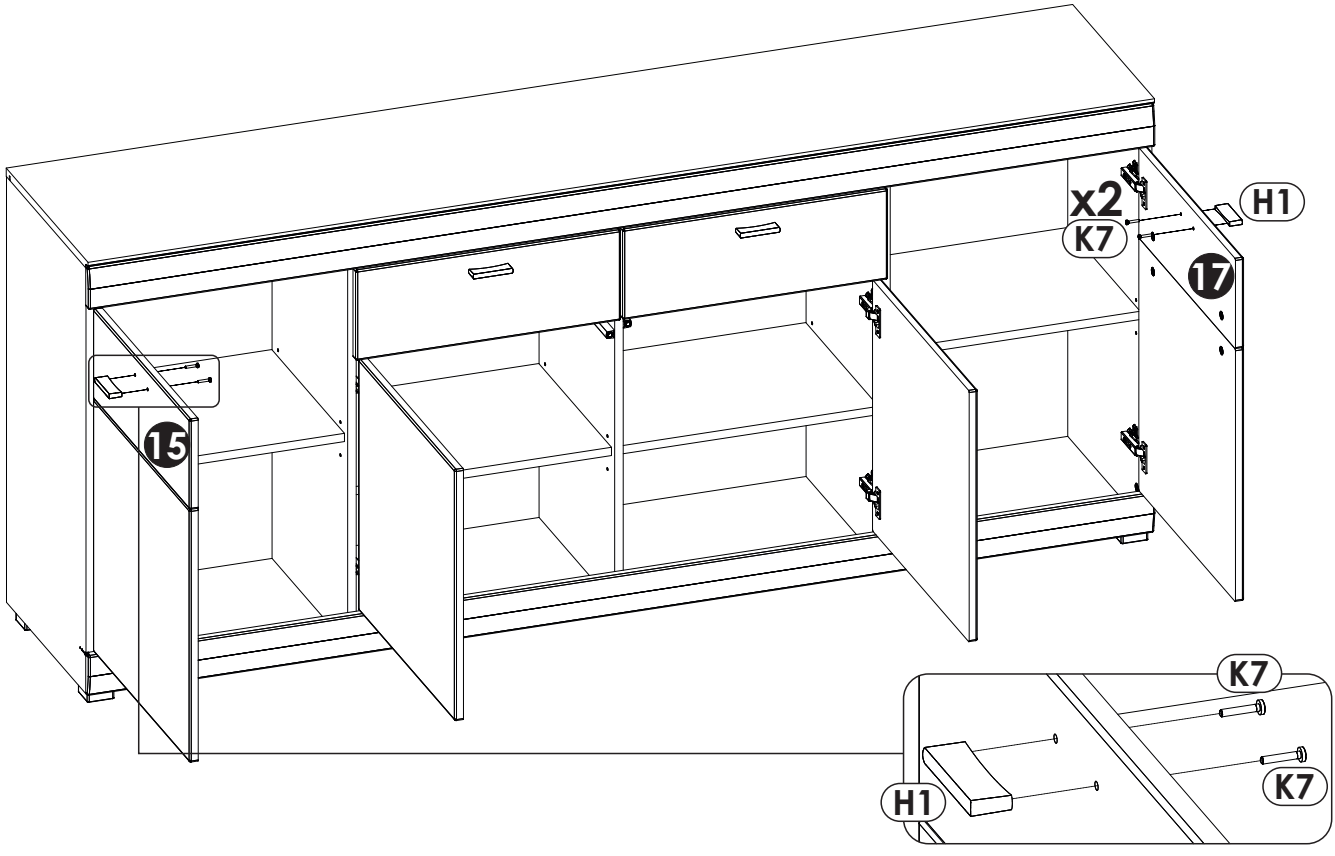

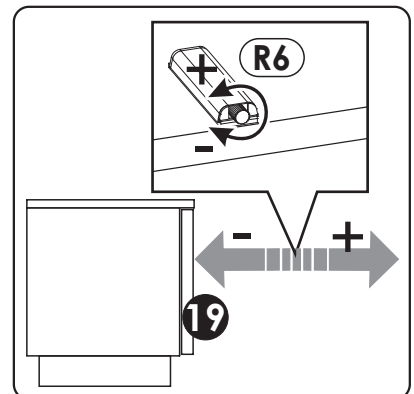
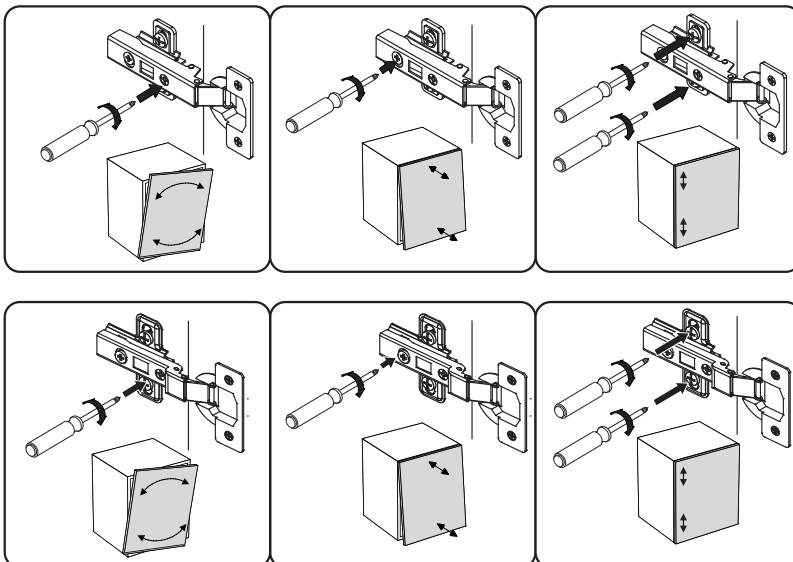
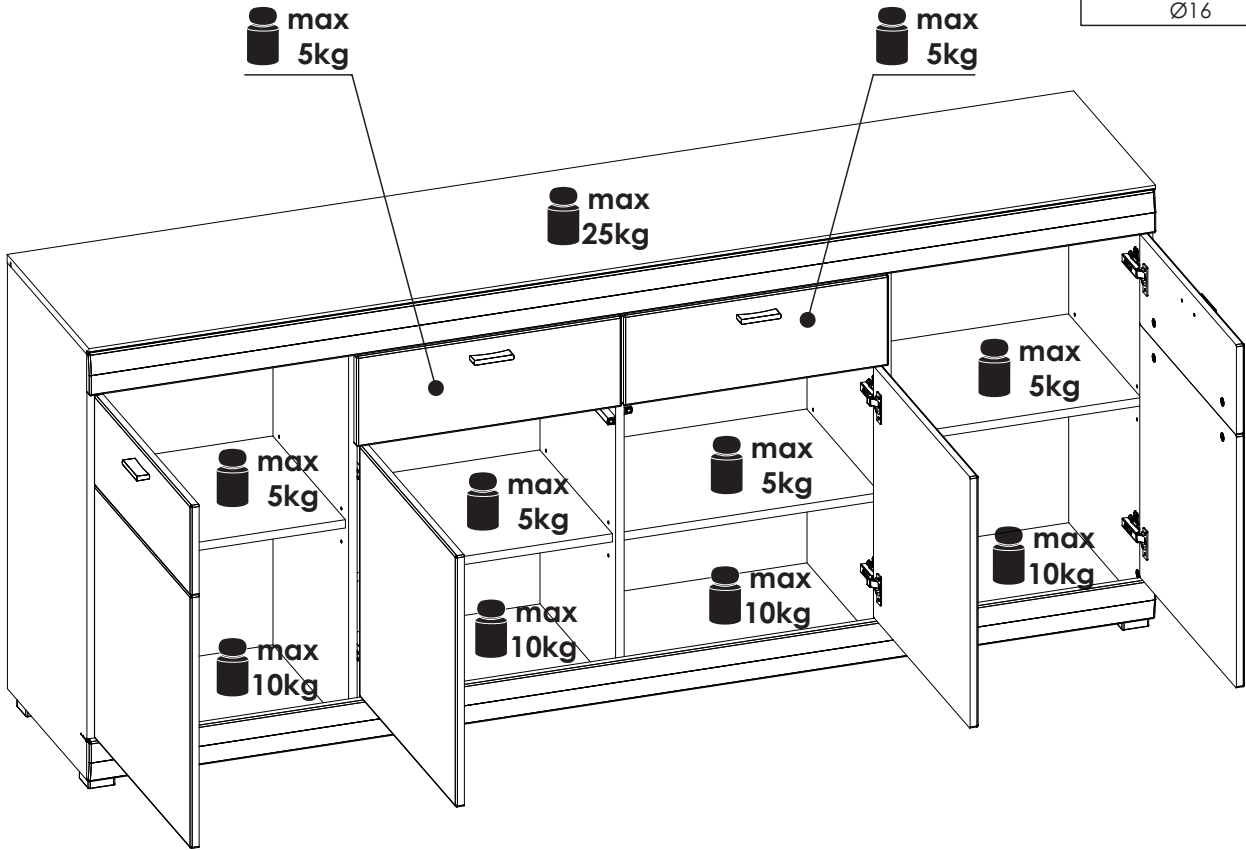
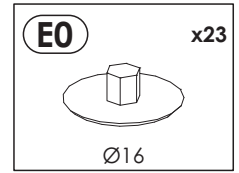
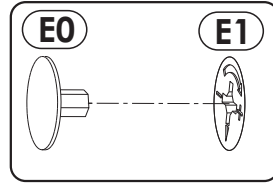

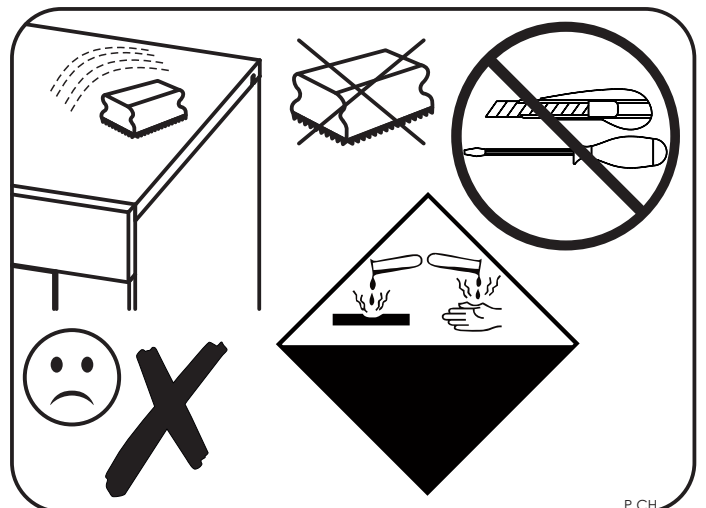
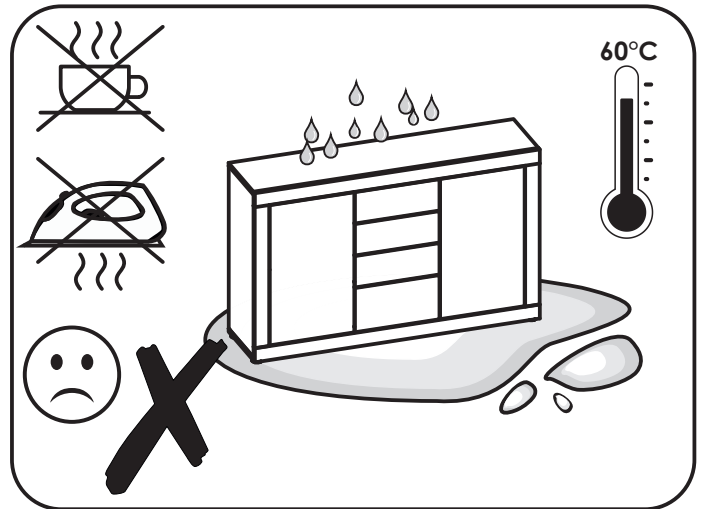
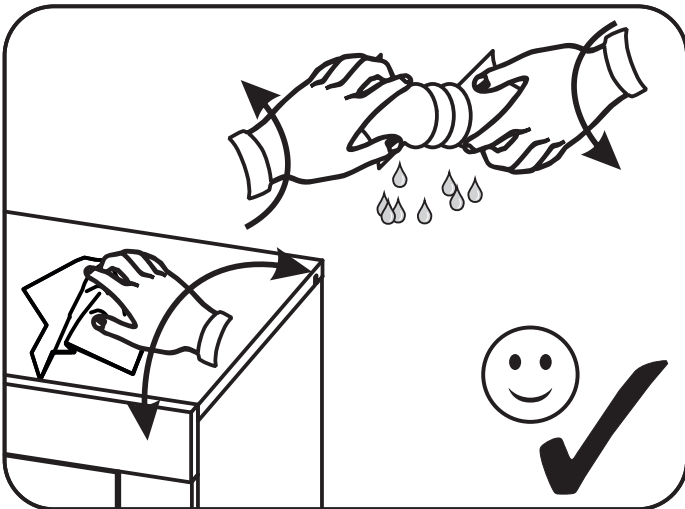
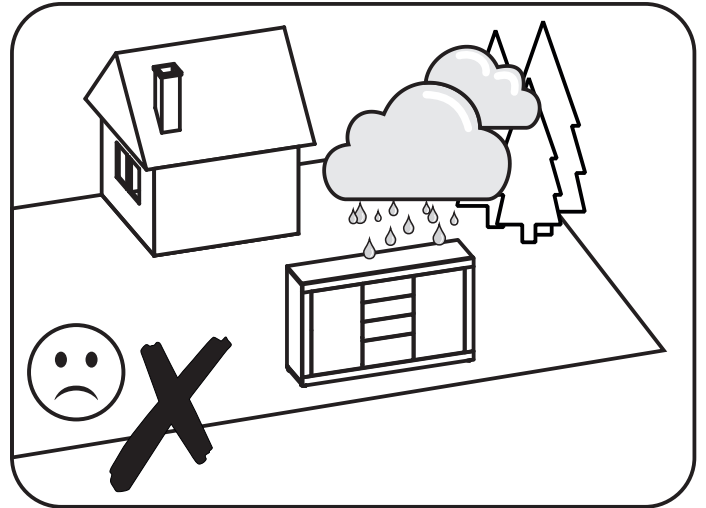
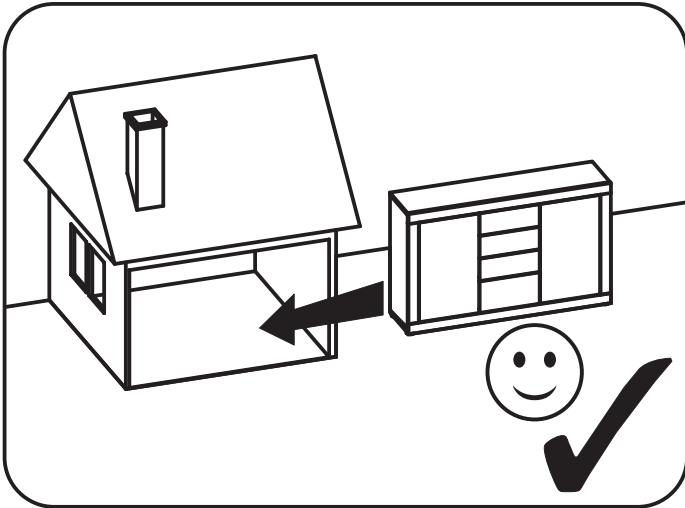

5EEH1256

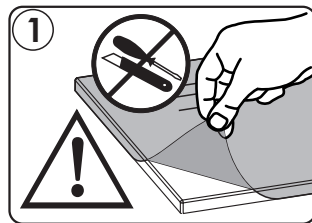
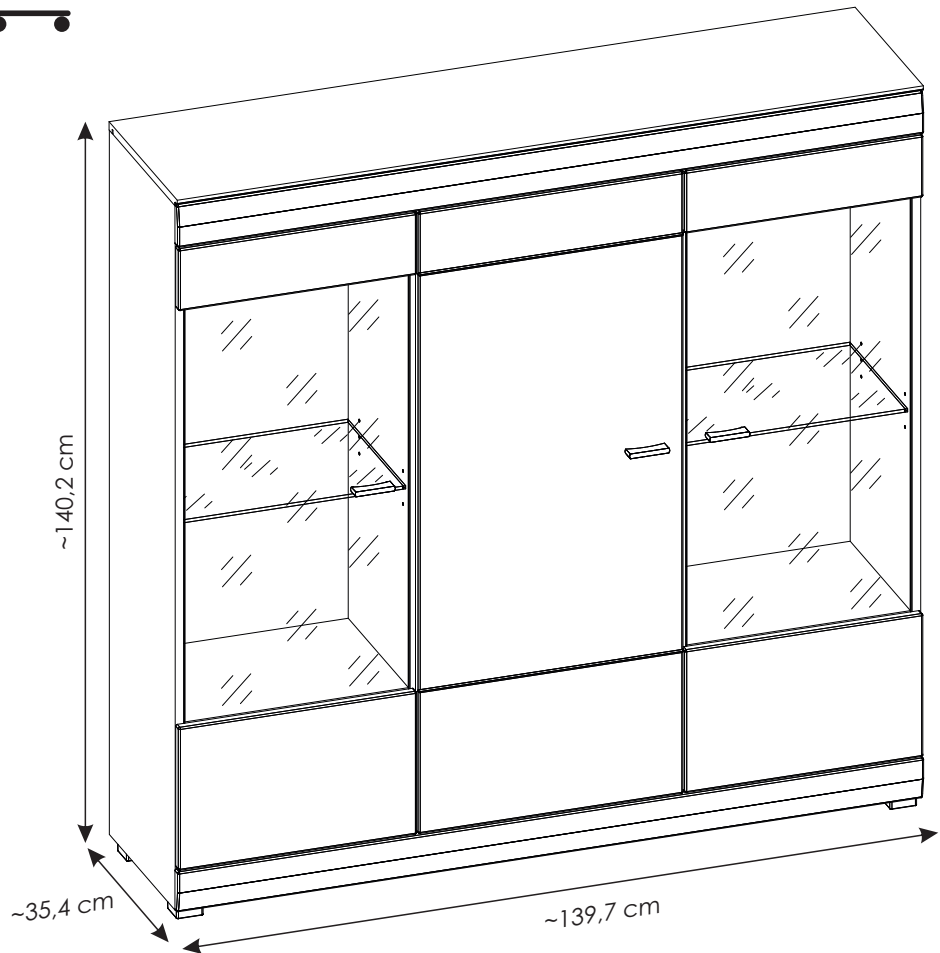
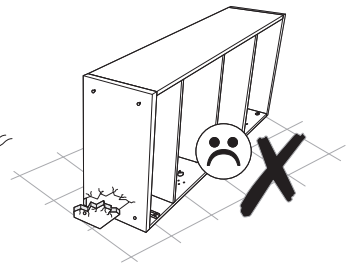
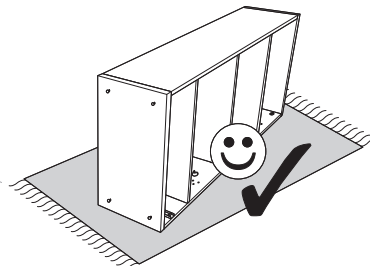
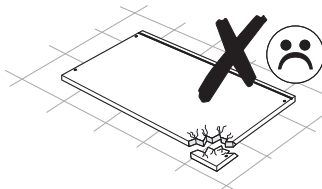
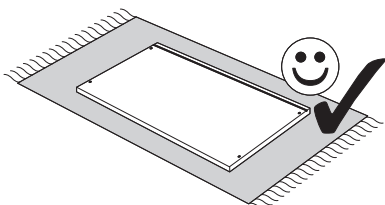
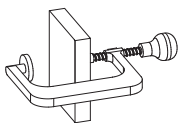
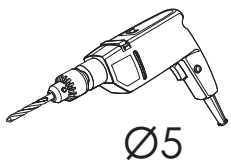
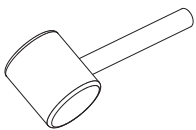
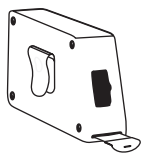
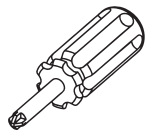
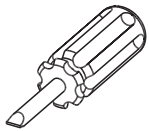
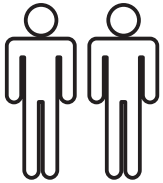

PL.

UWAGA! Mebel należy trwale zamocować do ściany, aby uniknąć ryzyka związanego z przewróceniem się mebla.

W paczce nie ma śrub mocujących, ponieważ rodzaj mocowania należy odpowiednio dobrać do rodzaju ściany. Dobierz właściwe do Twojego rodzaju ściany.

D.

ACHTUNG! Um alle mit dem Umkippen des Möbels verbundenen Risiken auszuschließen, muss das Möbel fest an der Wand verankert werden. Beschläge für die Wandbefestigung sind nicht beige packt, da diese von der jeweiligen Wandbeschaffenheit abhängig sind. Bitte solche Befestigungsschläge wählen, die für die heimischen Wände geeignet sind.

FR.

ATTENTION! Ce meuble doit être fixé en permanence au mur pour éviter les risques de chute. Les vis de fixation ne sont pas livrées car le type de fixation doit être choisi en fonction du type de mur. Sélectionnez les fixations adaptées au mur.

I.

ATTENZIONE! Il mobile deve essere permanentemente fissato alla parete per evitare i rischi derivanti da un ribaltamento del mobile. La confezione non include le viti di fissaggio, in quanto il tipo di fissaggio deve essere scelto in base al tipo di parete. Utilizzare viti appropriate in base al materiale della parete.

HR.

NAPOMENA! Namještaj mora biti trajno pričvršćen za zid, kako bi se izbjegao rizik od njegovog prevrtanja. U paketu nema vijaka za pričvršćivanje, jer se vrsta montaže mora prilagoditi vrsti zida. Odaberite pravu vrstu prema Vašoj vrsti zida.

EN.

WARNING! To prevent this furniture from tripping over, fix it to the wall permanently. Fixing devices are not included since different wall materials require different types of fixing devices. Please make sure you chose the correct ones for your type of wall.

SK.

POZOR! Nábytok musí byť trvalo pripevnený k stene tak, aby sa zamedzilo riziku prevrátenia. Balík neobsahuje upevňovacie skrutky, pretože typ upevnenia je treba vybrať podľa typu steny. Vyberte typ vhodný pre Vašu stenu.

CZ.

POZOR! Nábytek je nutné pevně připevnit ke zdi, abychom se vyhnuli riziku spojenému s jeho převrnutím. Součástí balení nejsou připevňovací šrouby, protože způsoby připevnění je nutné zvolit podle druhu stěny. Vyberte správný pro Váš typ stěny.

RU.

ПРИМЕЧАНИЕ! Эту мебель необходимо всегда прикреплять к стене, чтобы избежать рисков, связанных с переворотом мебели. В пакете нет крепежных винтов, потому что тип крепления должен быть выбран в соответствии с типом стены. Выберите, пожалуйста, правильные винты к вашей стене.

RO.

ATENȚIE! Mobila trebuie ancorată permanent în perete pentru a evita riscul de răsturnare a mobilei. În pachet nu sunt incluse șuruburile de fixare, deoarece tipul de ancoraj trebuie ales în funcție de tipul de perete. Alegeți șuruburile potrivite pentru tipul Dvs. de perete.

TR.

DİKKAT! Devrilme riskini önlemek için mobilya duvara sabitlenmelidir. Sabitleme civataları pakete dahil değil, çünkü sabitleme tertibatının tipi, duvara tipine uygun olarak seçilmelidir. Onu duvarınızın tipine göre seçiniz.

AR.

ملاحظة!

يجب تثبيت الأثاث بإحكام إلى الحائط أو الجدار لتجنب خطر انقلابه. لا تحتوي العلبة على مسامير التثبيت، إذ إنه ينبغي استعمال المسامير المخصصة لنوعية الحائط أو الجدار. اختر المسامير التي تناسب جدارك.

E.

¡ATENCIÓN! El mueble debe ser fijado permanentemente a la pared para evitar el riesgo relacionado con el vuelco del mueble. En el paquete no hay tornillos de fijación, ya que se debe elegir el tipo de fijación adecuado para el tipo de pared. Elija el apropiado para su tipo de pared.

CN.

注意！本家具需要固定在墙上以免倒塌。箱子里没有安装螺钉。因为安装方式需要根据墙的类型调整。请按照您的墙类型选择合适的安装方式。

SLO.

POZOR! Pohištvo trajno pritrdite na steno, da preprečite tveganje, da se prevrne. V paketu ni pritrdilnih vijakov, saj je treba način pritrditve ustrezno izbrati glede na vrsto stene. Izberite način, ki je ustrezen za vašo steno.

HU.

FIGYELEM! Rögzítse a bútorokat a falhoz, hogy elkerülje a bútor felborulásának kockázatát. A készletben nem találhatóak rögzítőcsavarok, mivel a rögzítés típusa a fal típusától függ. Válassza ki a fal típusának megfelelő kötőelemeket.

NL.

OPMERKING! De meubelen moeten permanent aan de muur worden bevestigd om te voorkomen dat de meubelen kantelen. Er zitten geen bevestigingsschroeven in het pakket, omdat het type bevestiging moet worden gekozen op basis van het type muur. Kies de juiste voor uw type muur.

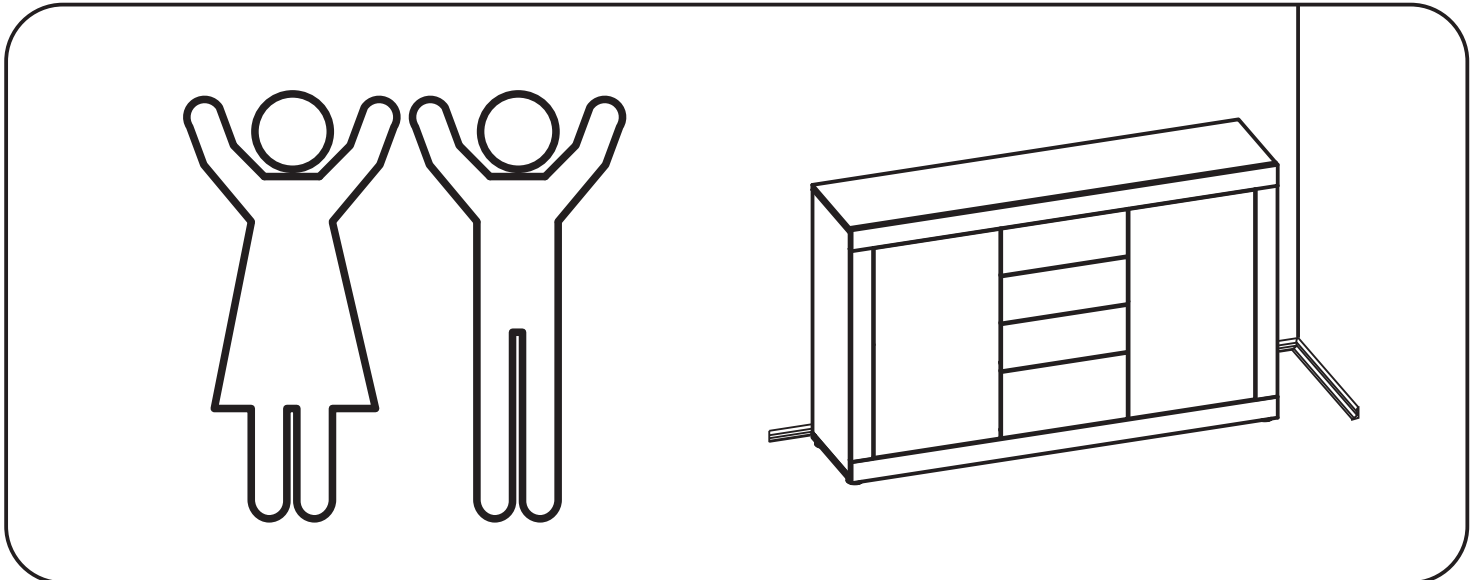
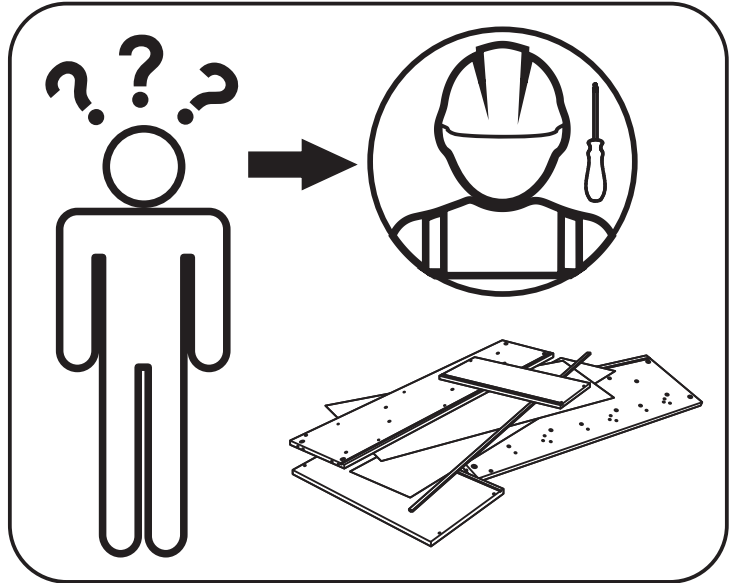
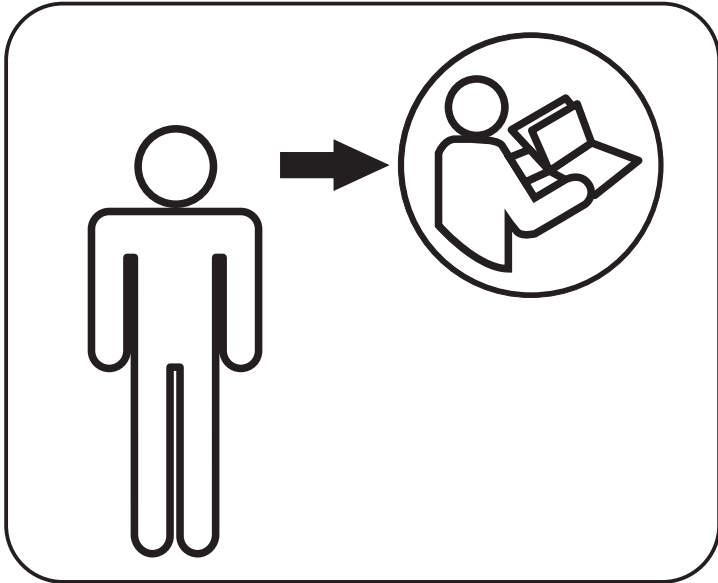
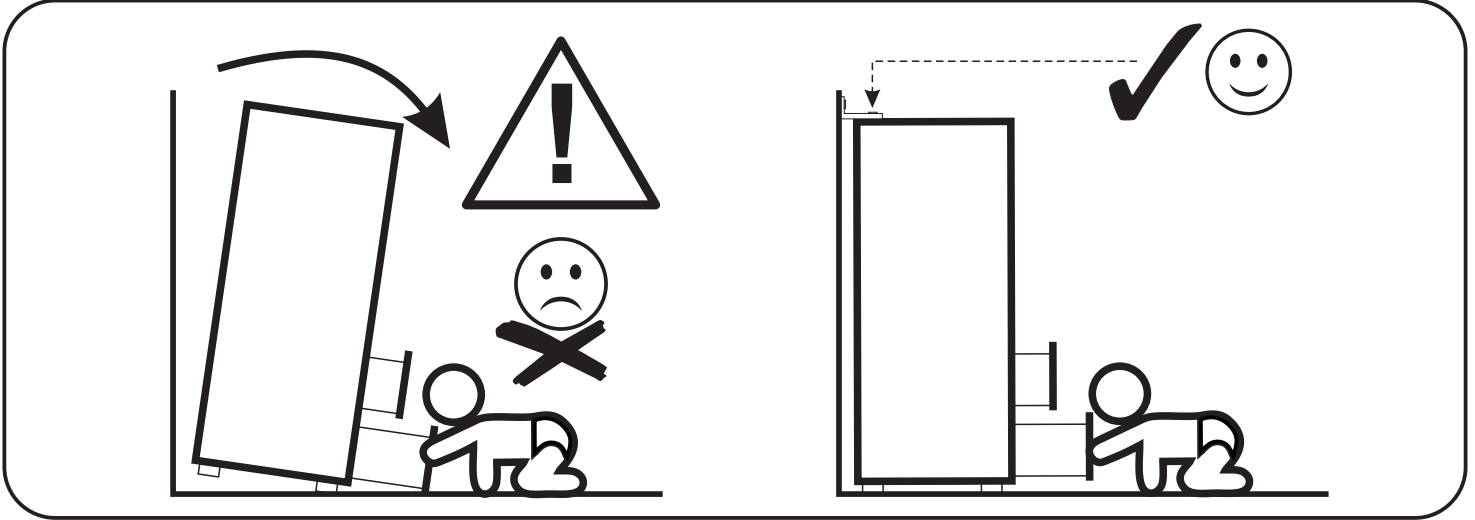
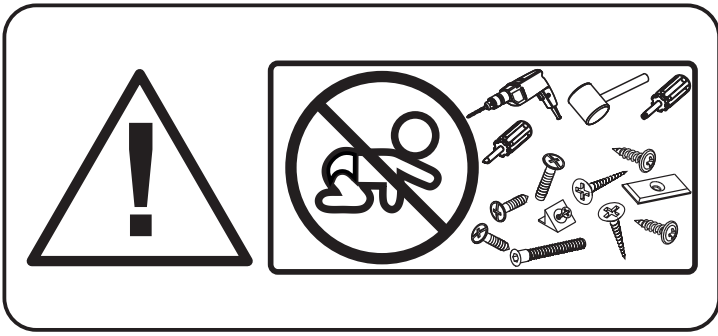



version A



version B

BCxx

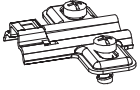

BCxx

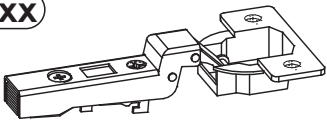

BCxx + BCxx

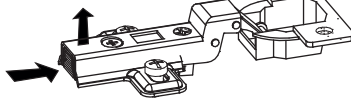

BCxx

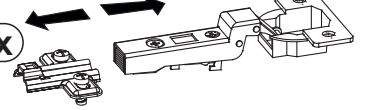

BCxx

BCxx

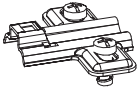

BCxx

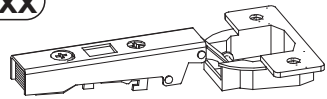

BCxx + BCxx

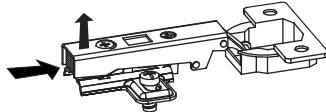

BCxx

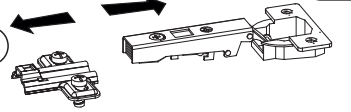

BCxx

BCxx

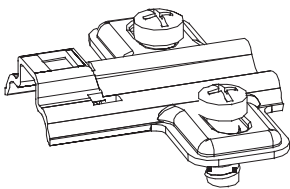

OK

BCxx

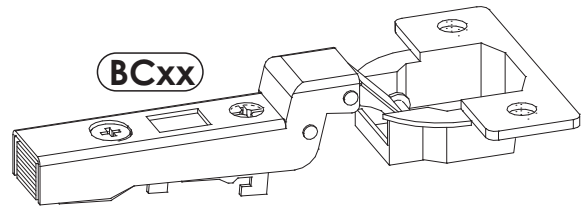

BCxx

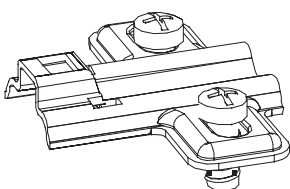





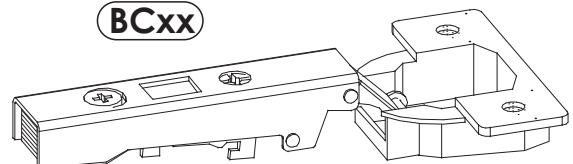



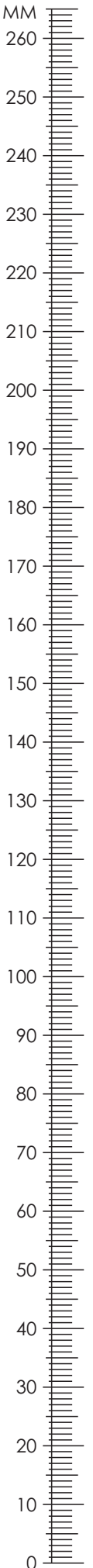



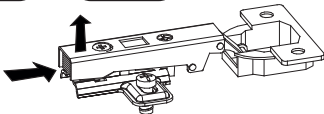
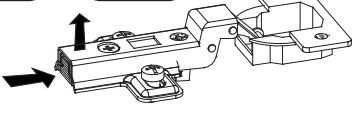

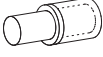
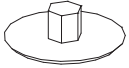
OK

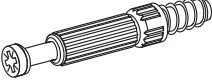
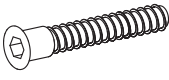
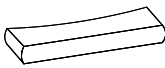
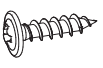
BCxx

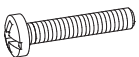
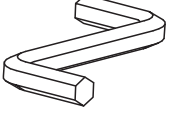

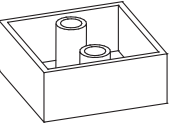
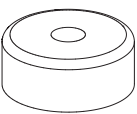
5EEH1256

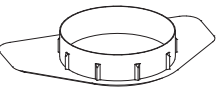
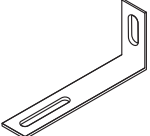
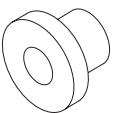
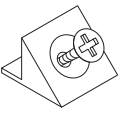

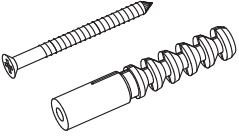
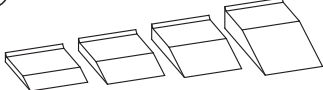
A1 8 x 35 mm x32 	BC11 + BC12 x4 	BC13 + BC14 x3 
C2 5 x 13 mm x14 	D2 x20 	E0 Ø16 x24 
E1 15 x 12 mm x28 	F1 6 x 34 mm x28 	G1 7 x 50 mm x4 
H1 L - 75 mm x3 	I2 4 x 16 mm x40 	I4 3,5 x 27 mm x10 
K4 4 x 12 mm x4 	K7 4 x 22 mm x2 	M x1 
N1 3 x 16 mm x10 	O6 x4 	O1 x2 
P0 x8 Ø5 	P23 x3 	Q9 x2 
R3 x12 	R4 x12 	R10 x2 
S13 x2 Ø8 	Z x1 	

5EEH1256

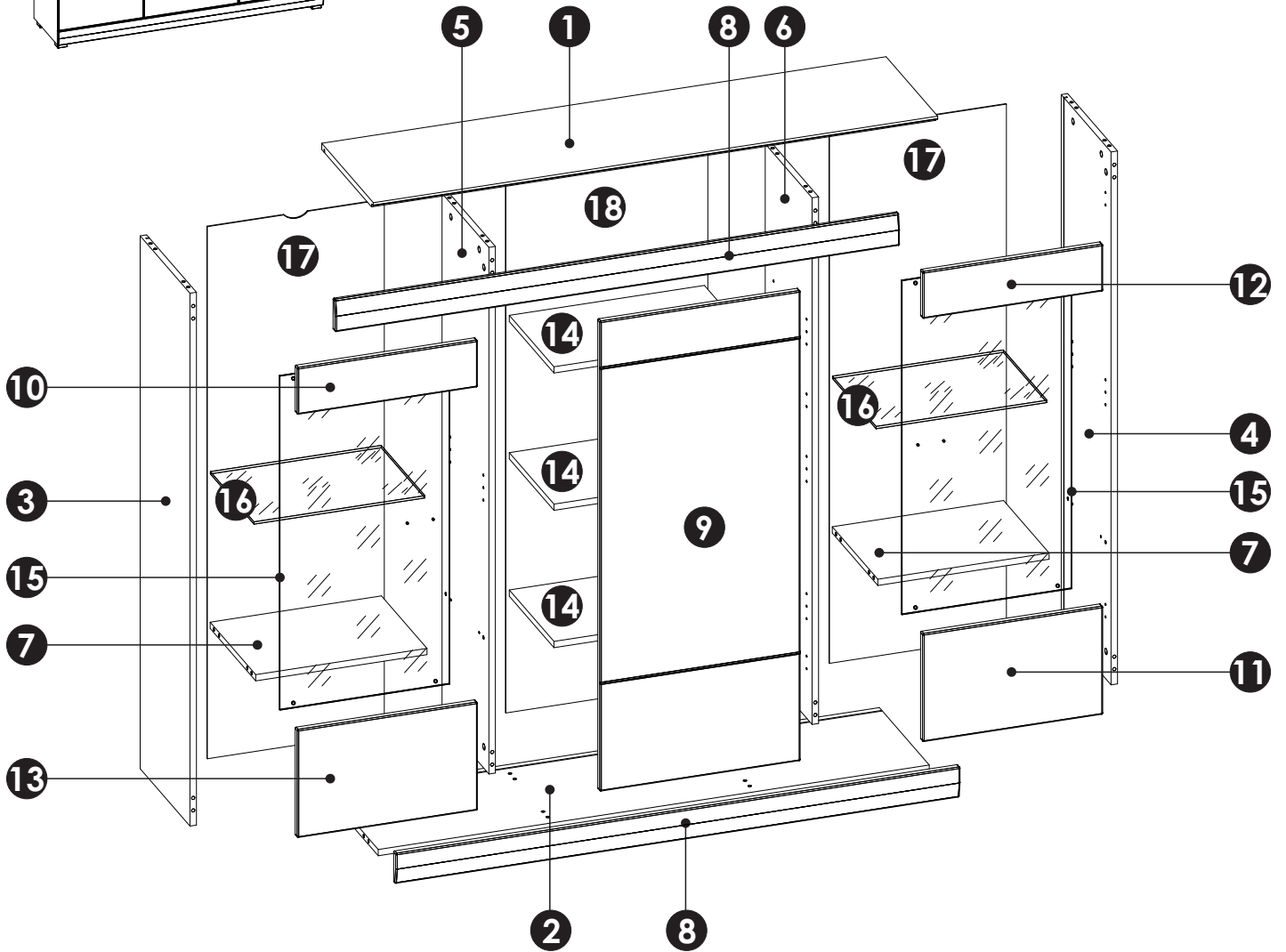
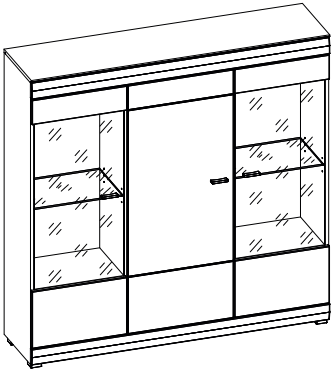

1	1397	350	16	x1	3/3	10	446	120	16	x1	1/3
2	1364	338	16	x1	2/3	11	446	277	16	x1	1/3
3	1366	338	16	x1	2/3	12	446	120	16	x1	1/3
4	1366	338	16	x1	2/3	13	446	277	16	x1	1/3
5	1350	318	16	x1	2/3	14	483	303	16	x3	1/3
6	1350	318	16	x1	2/3	15	856	420	4	x2	3/3
7	424	309	16	x2	1/3	16	423	291	6	x2	1/3
8	1397	80	16	x2	3/3	17	438	1364	3	x2	3/3
9	496	1205	16	x1	3/3	18	1364	500	3	x1	3/3

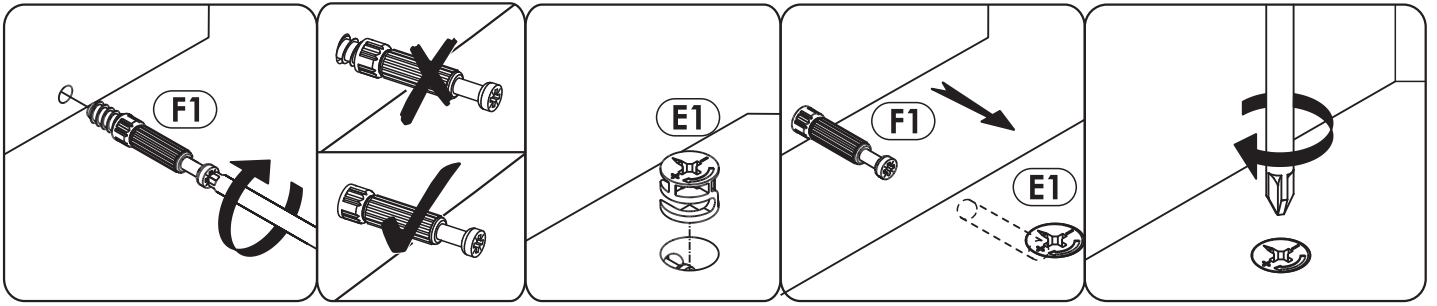

1 ▶

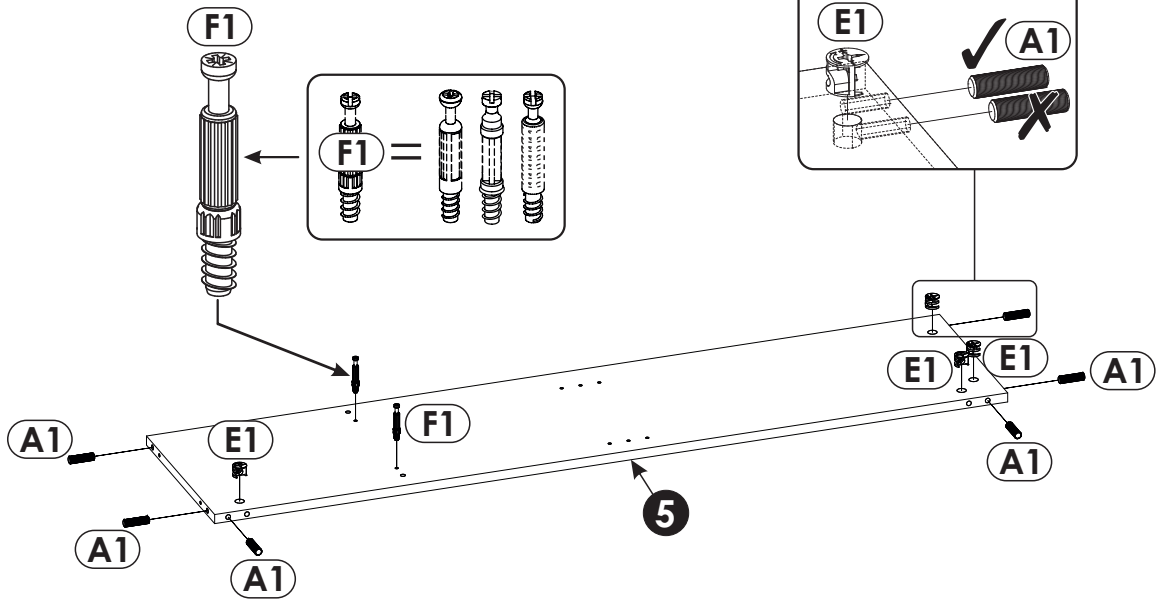
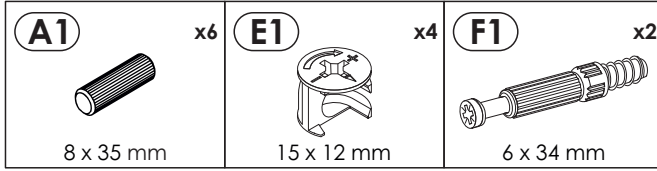

2 ▶

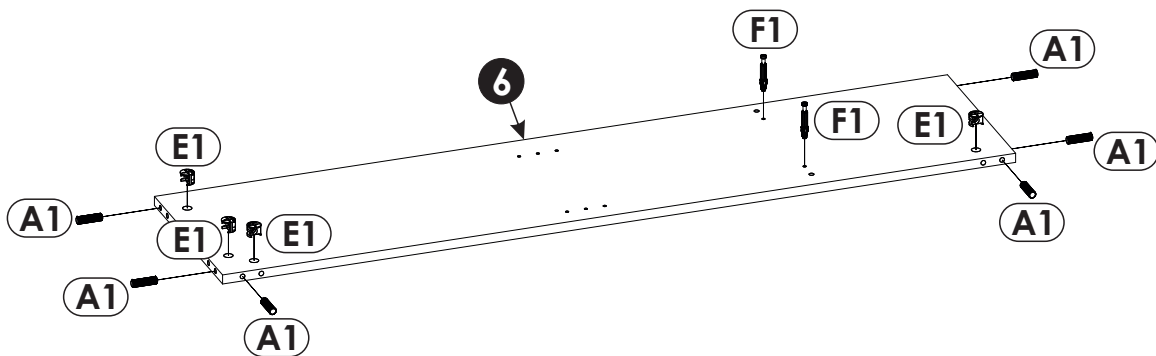
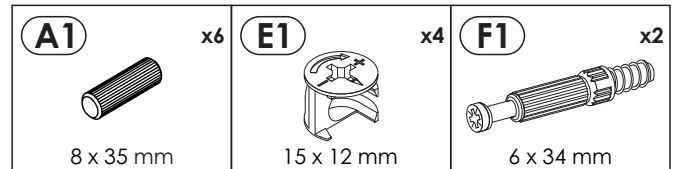

3 ▶

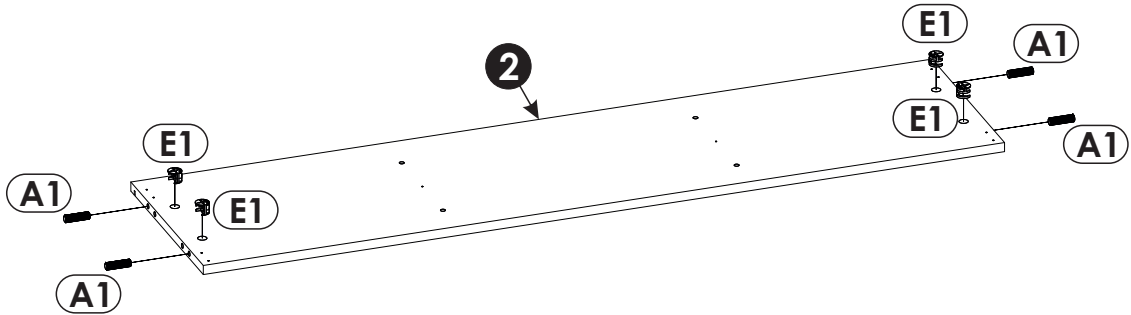
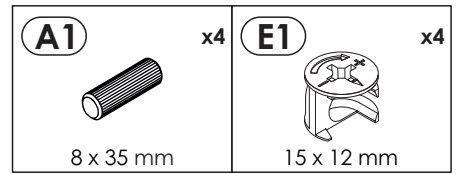

4 ▶

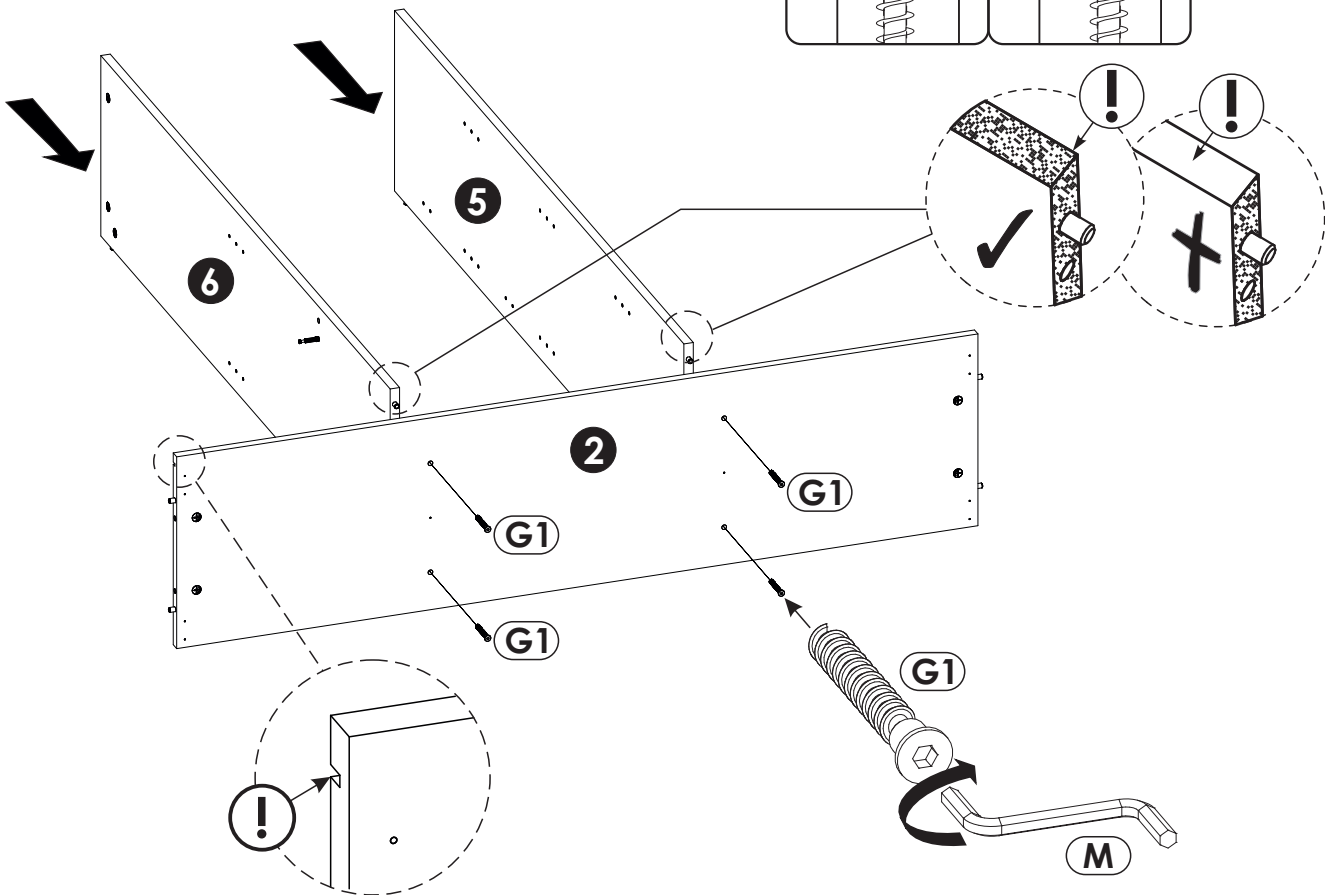
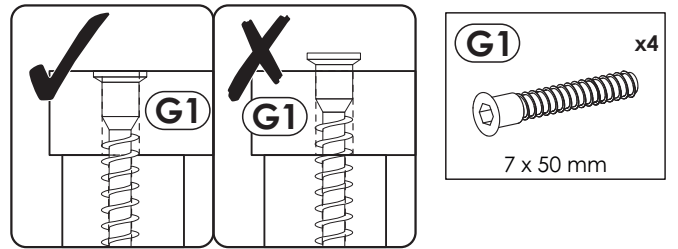

5 ▶

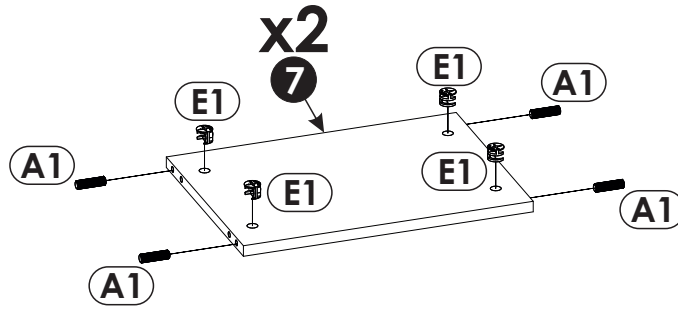
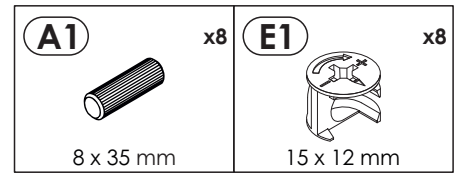

6 ▶

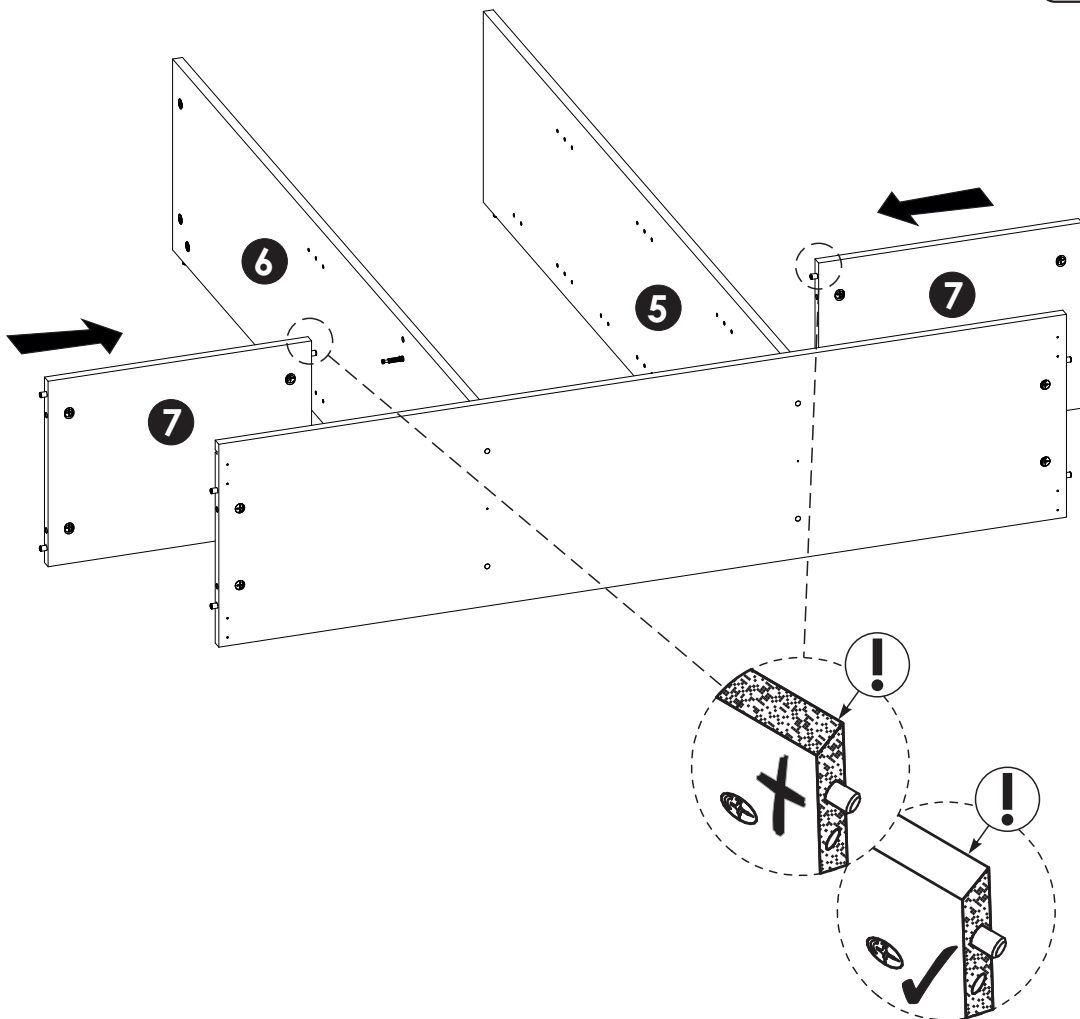
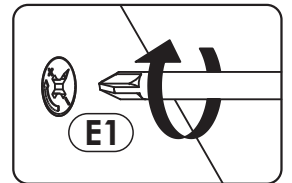

7 ▶

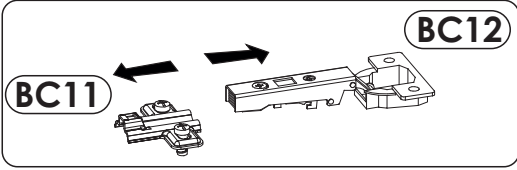

A1	x4	BC11	x2	E1	x4	F1	x4
8 x 35 mm				15 x 12 mm		6 x 34 mm	

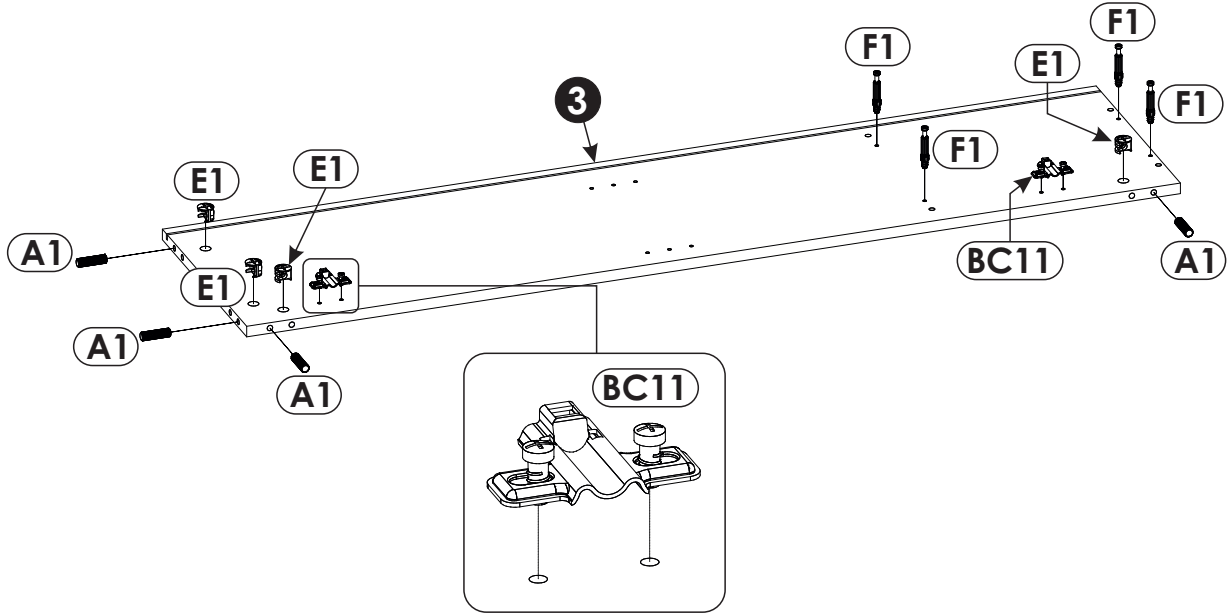

8 ▶

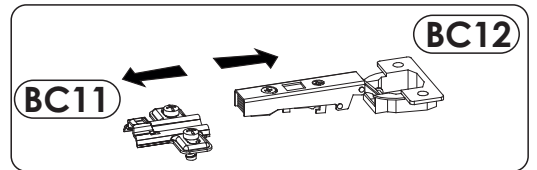

A1	x4	BC11	x2	E1	x4	F1	x4
8 x 35 mm				15 x 12 mm		6 x 34 mm	

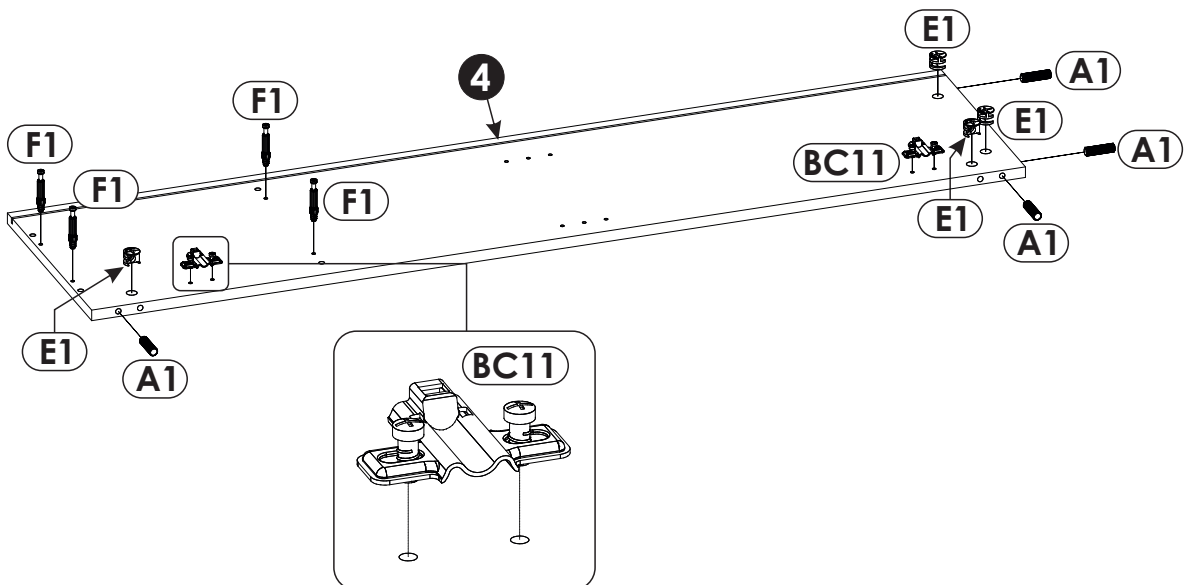

9 ▶

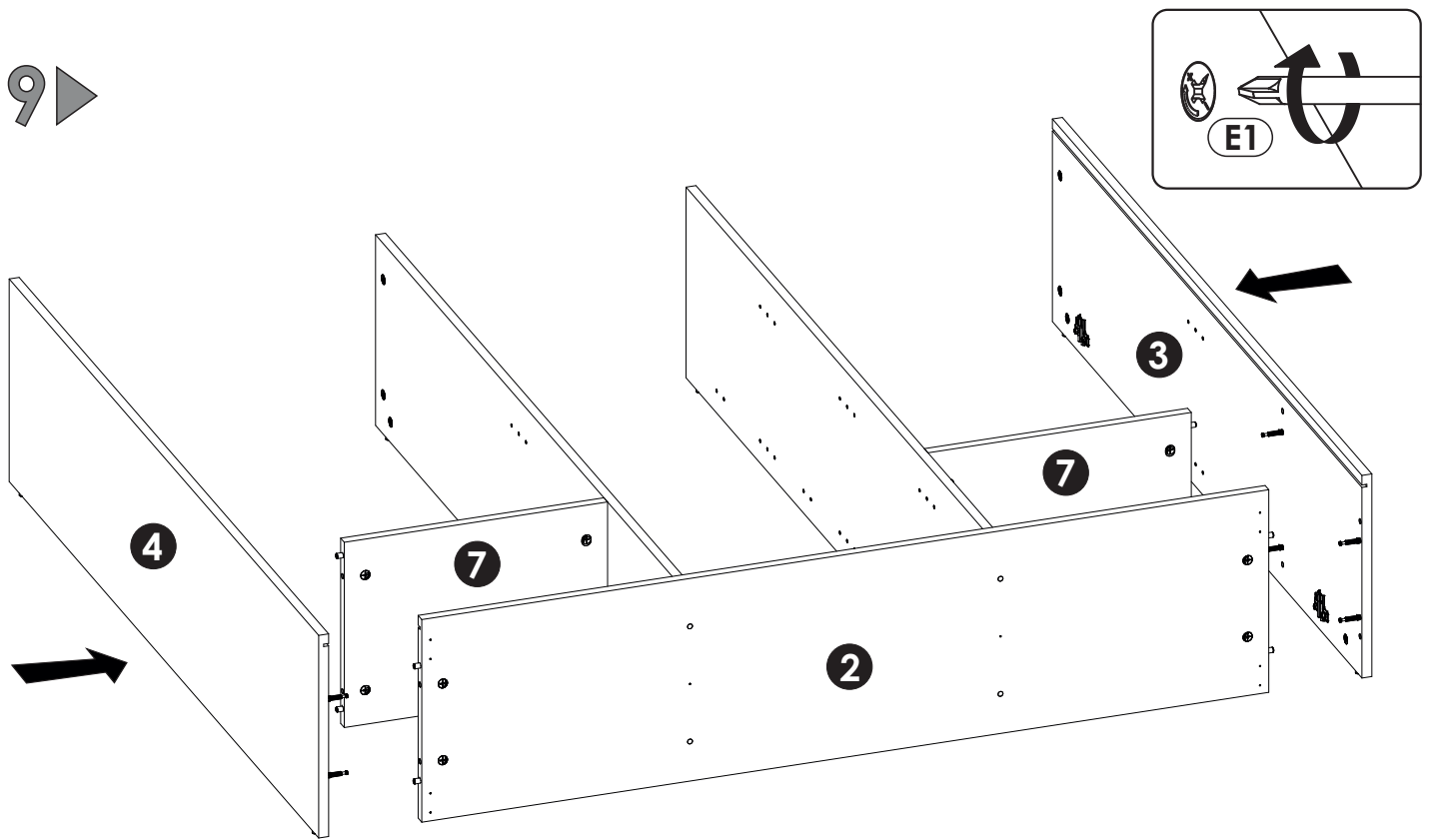

10 ▶

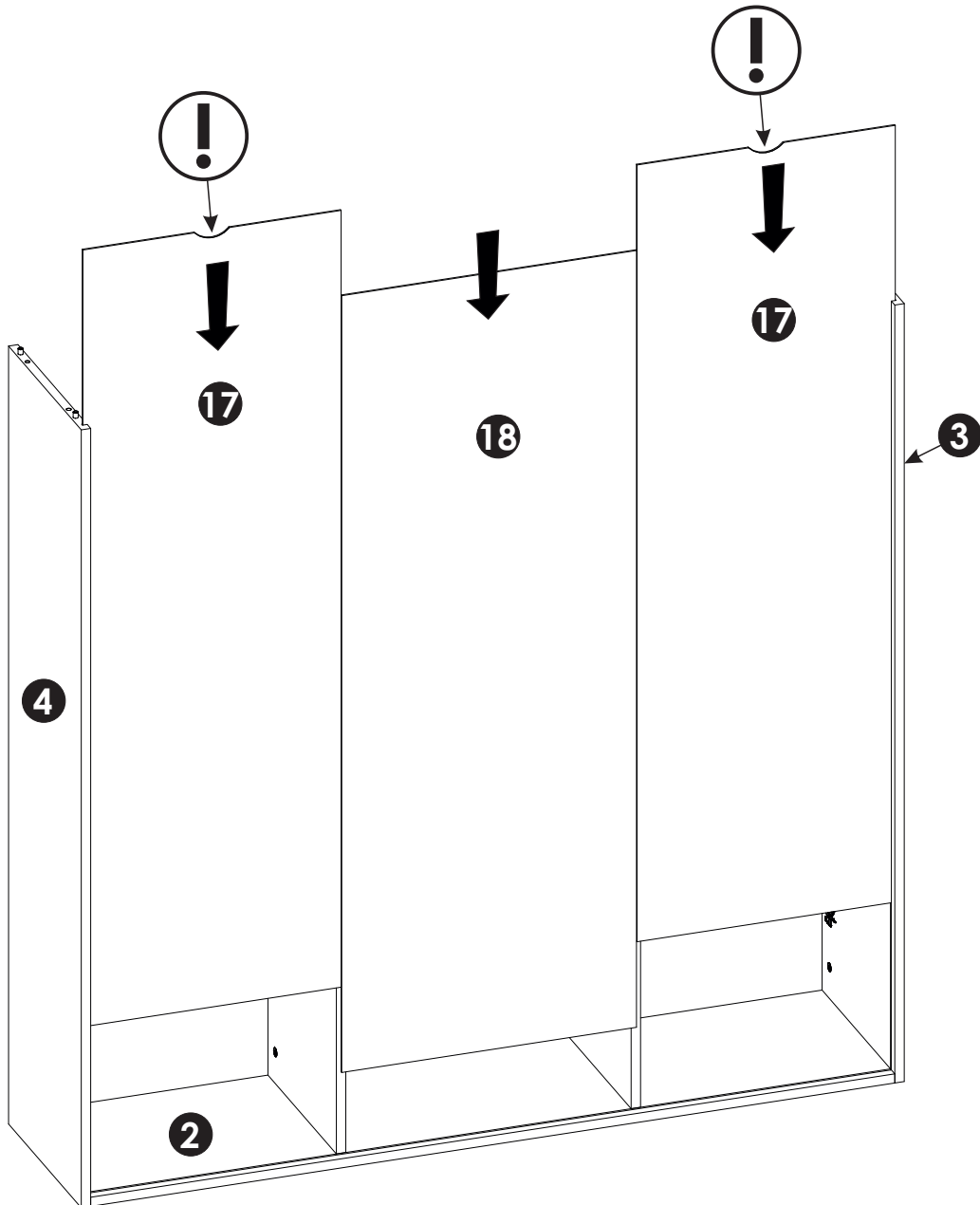
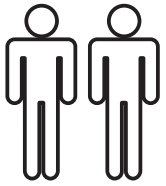

13 ▶

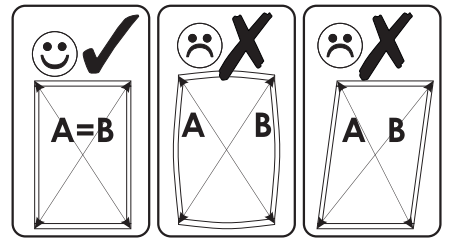

A=B

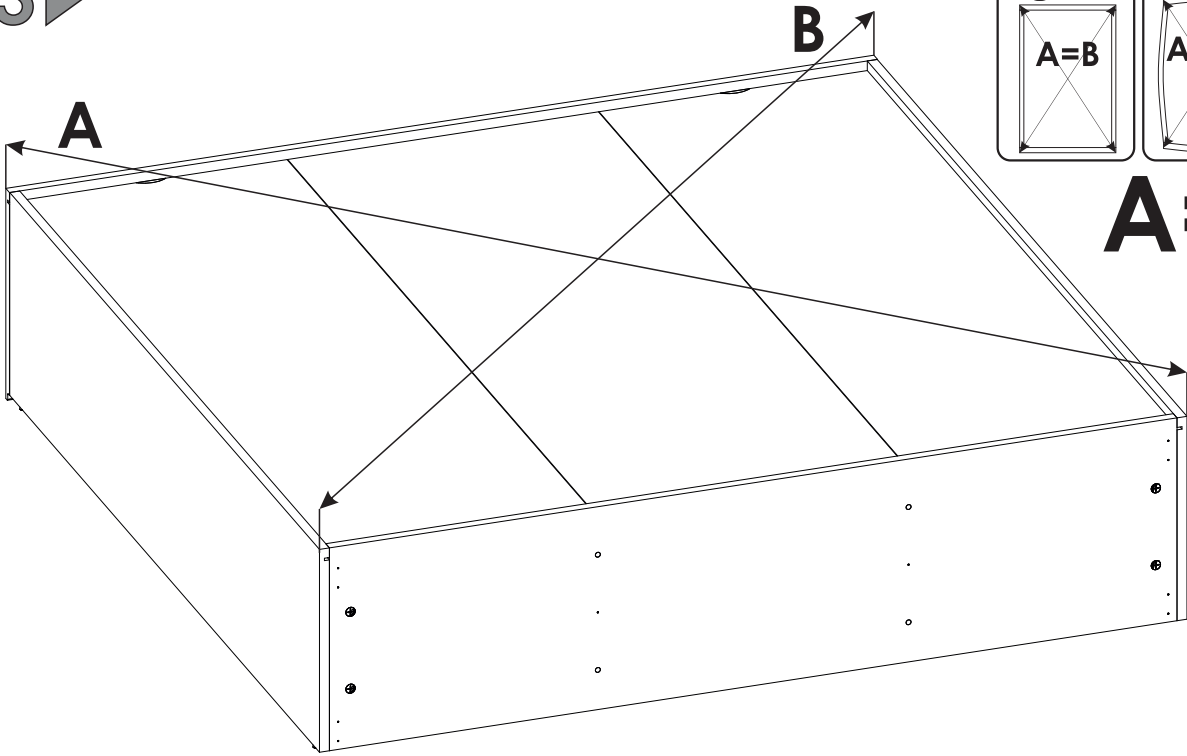

14 ▶

I2	x26	I4	x10	O1	x2	O6	x4	R4	x12
4 x 16 mm		3,5 x 27 mm							

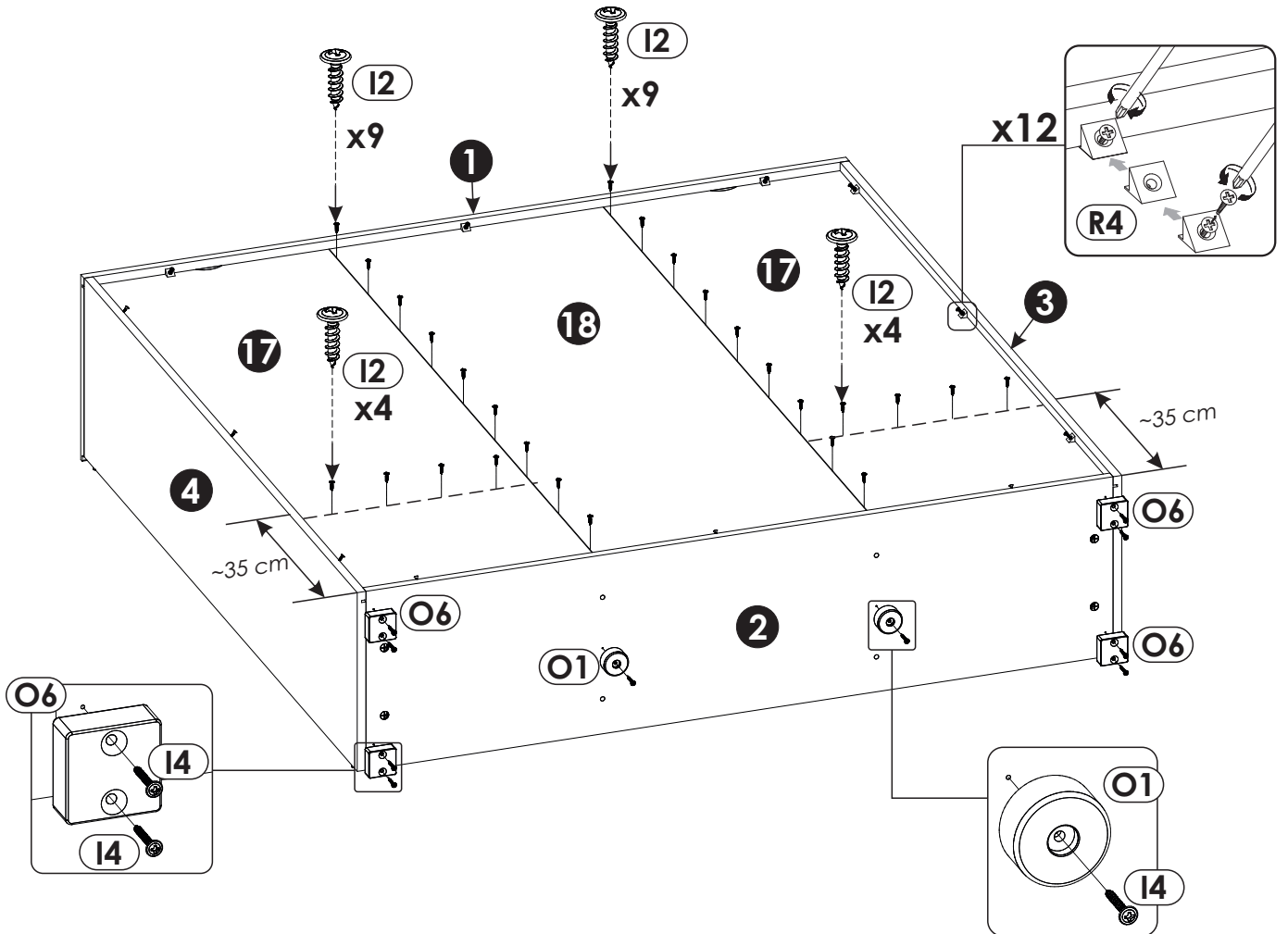

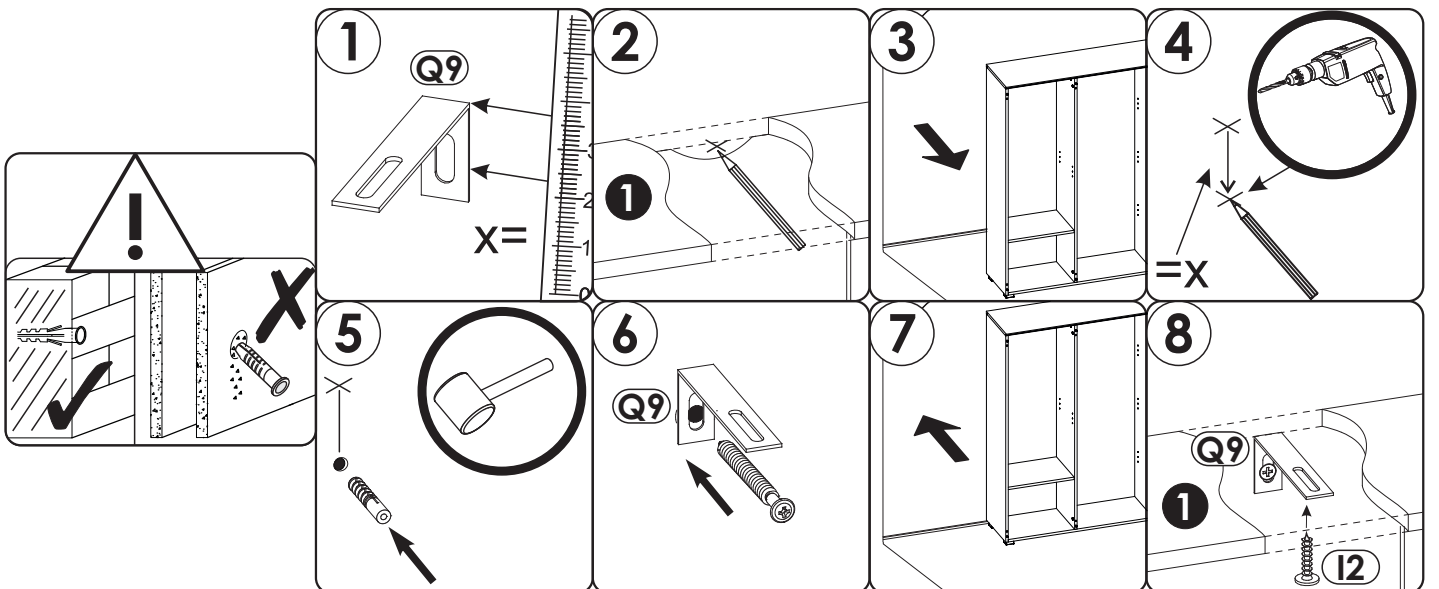
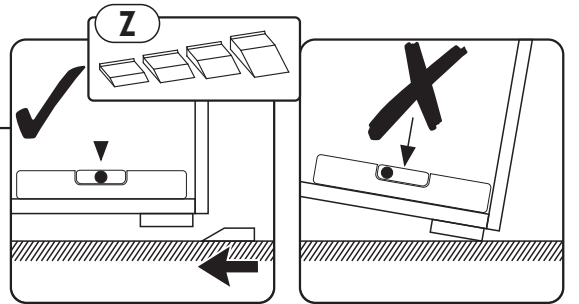
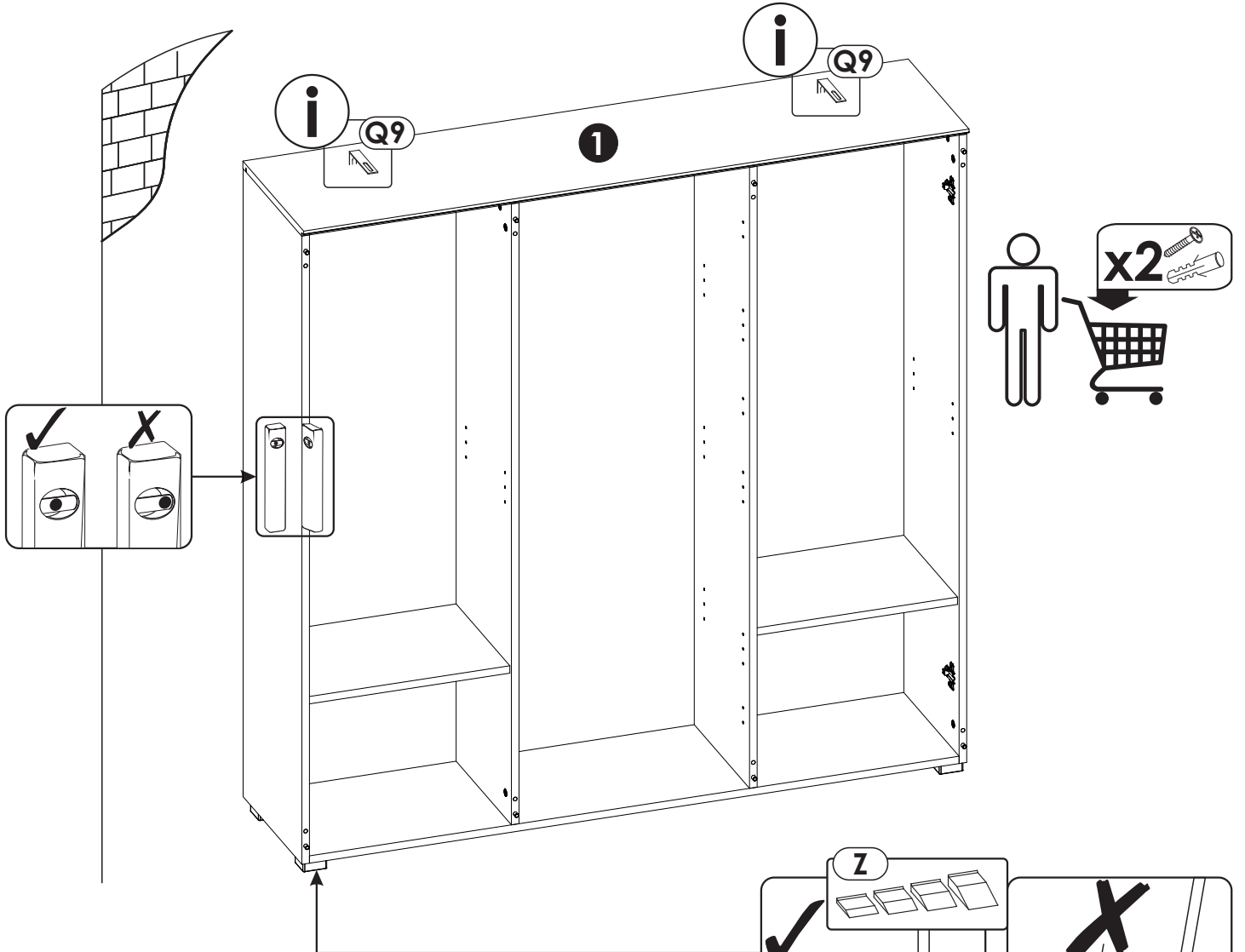
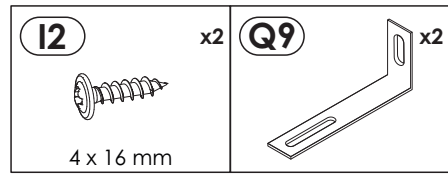

16 ▶

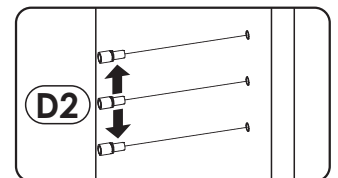
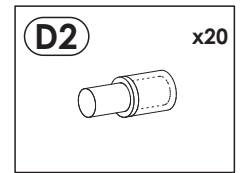
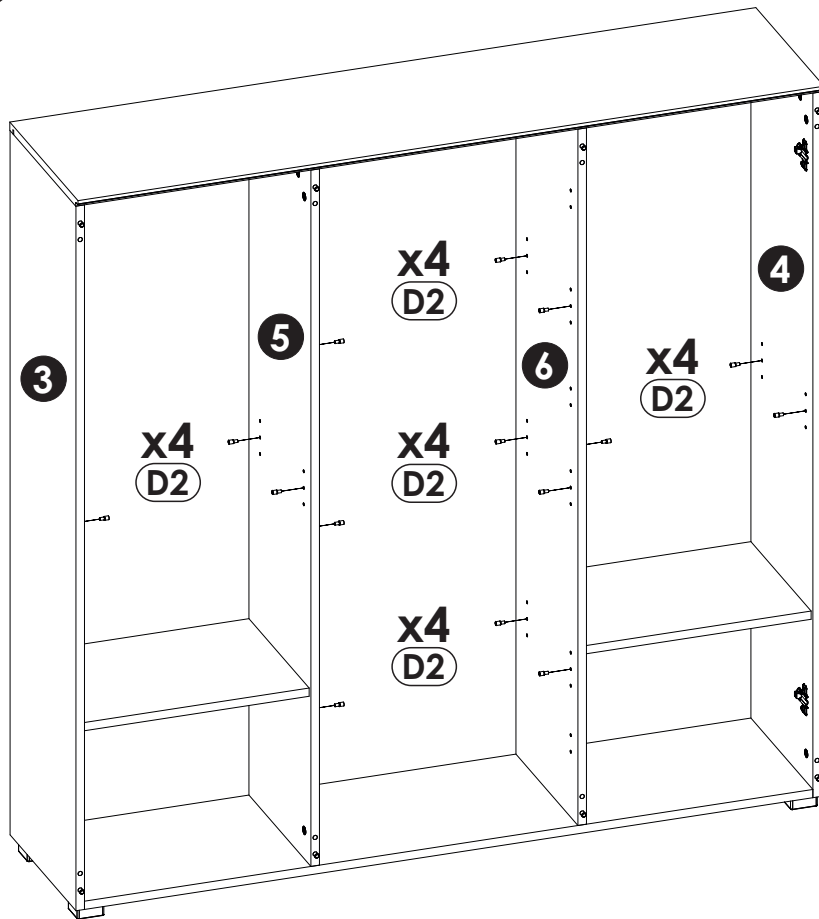

17 ▶

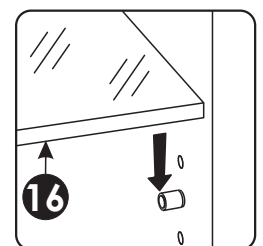
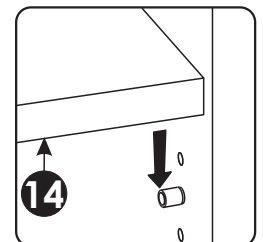
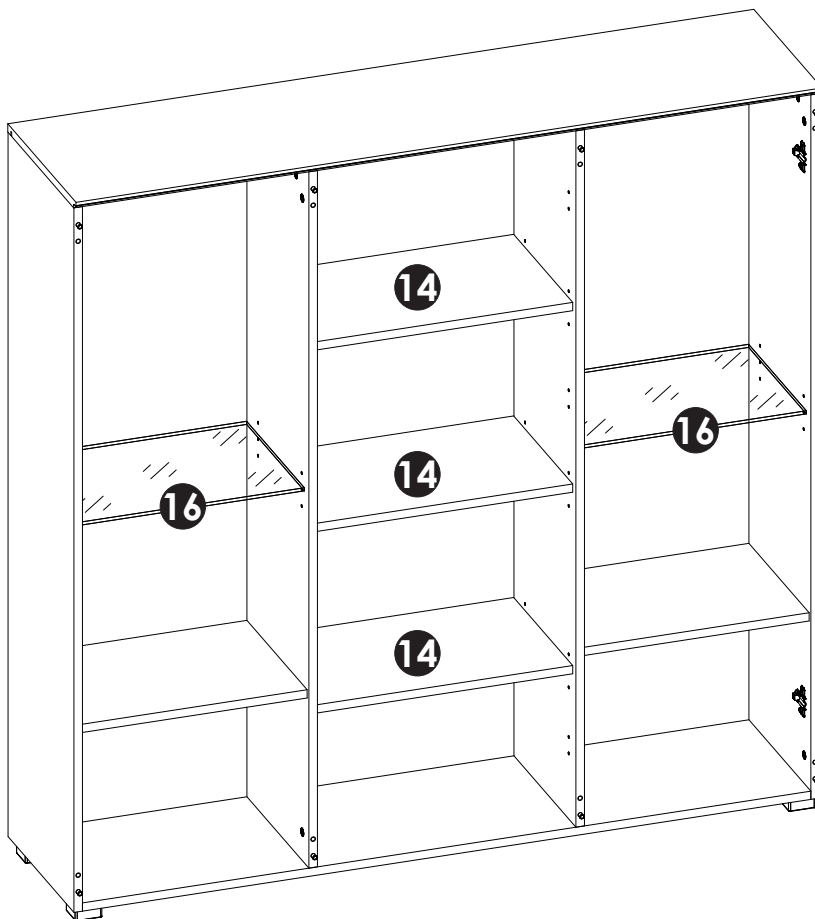

18 ▶

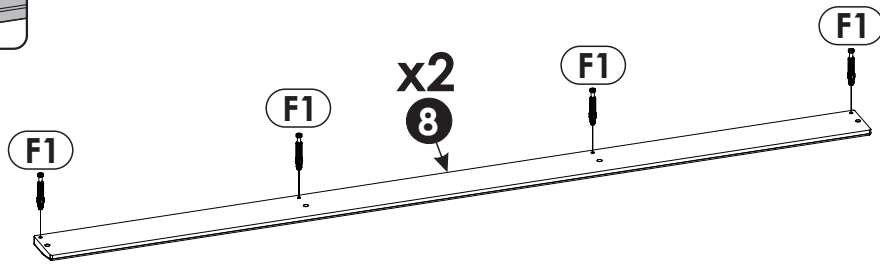
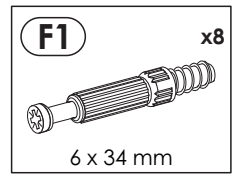
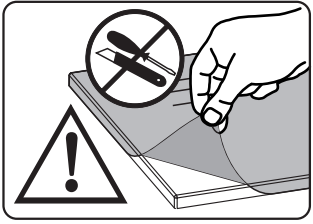

19 ▶

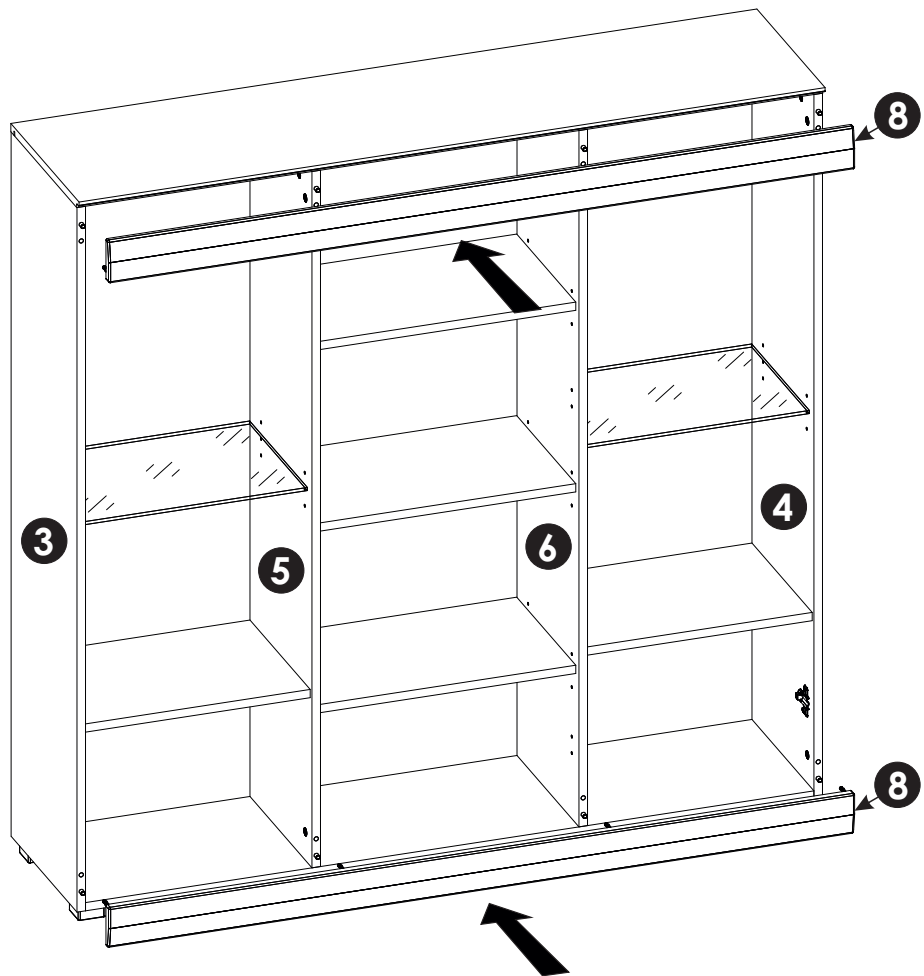
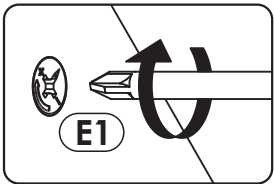

20 ▶

L

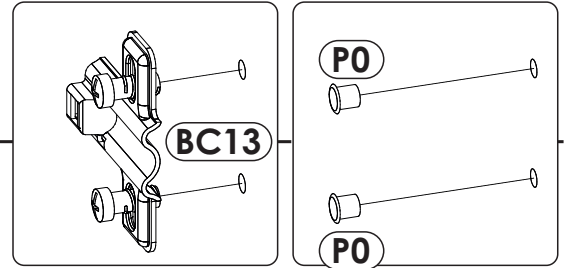
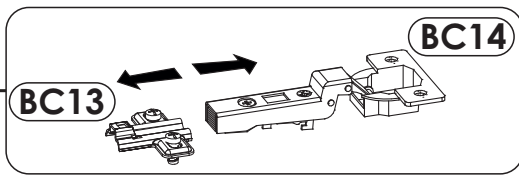
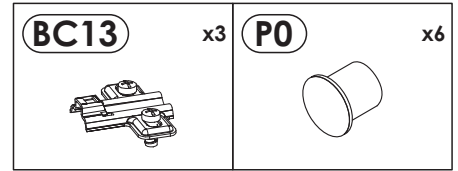
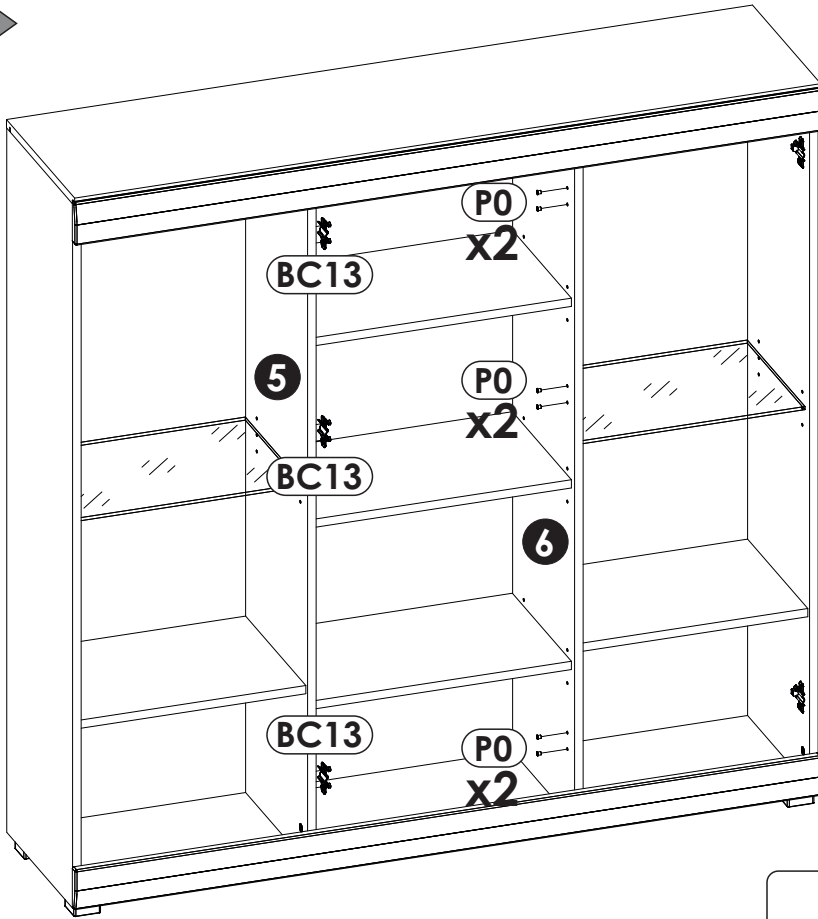

R

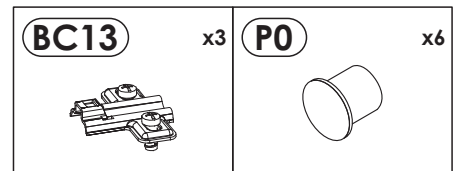
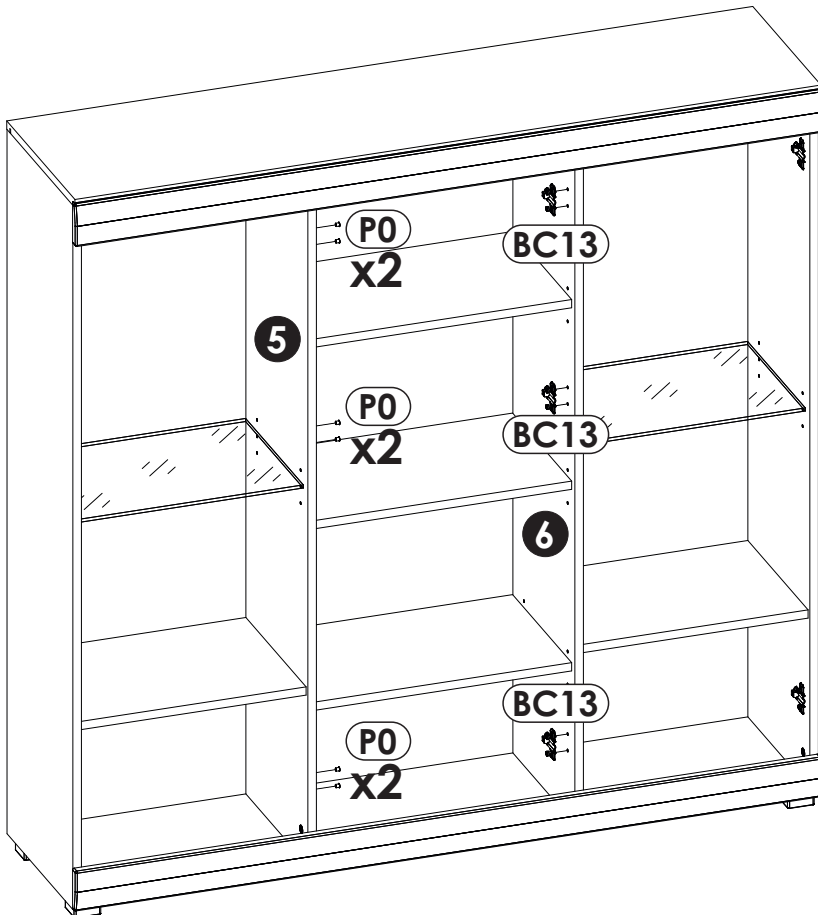

21 ▶

L

BC14 x3	C2 x6 5 x 13 mm	P0 x2 Ø5
----------------	---------------------------	--------------------

P23 x3

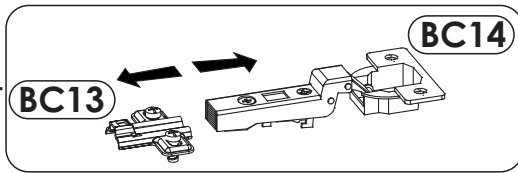
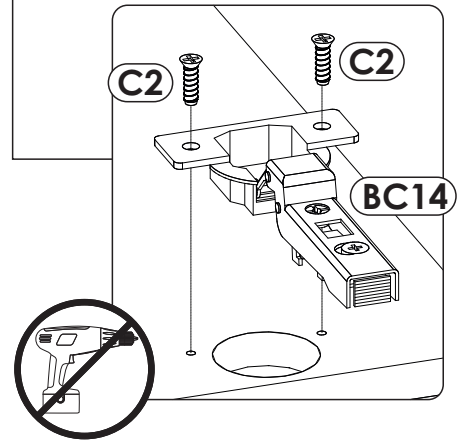
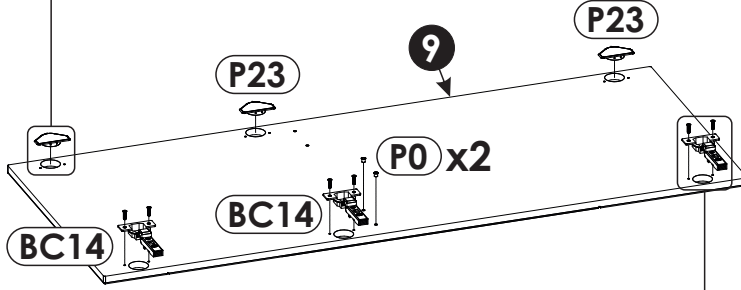
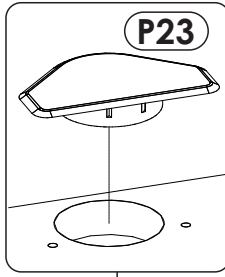

BC14 x3	C2 x6 5 x 13 mm	P23 x3
----------------	---------------------------	---------------

P23 x3

R

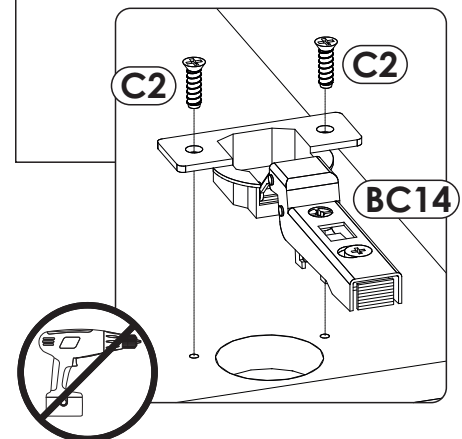
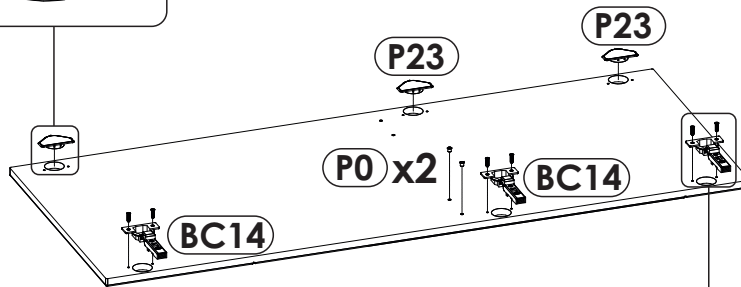
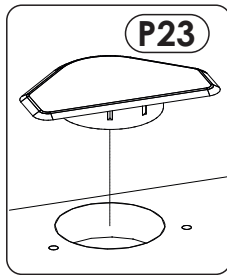

22 ▶

L

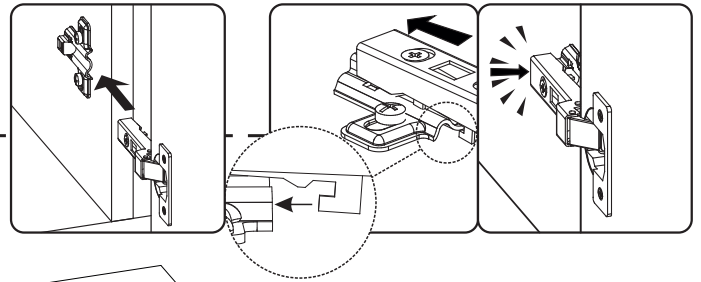
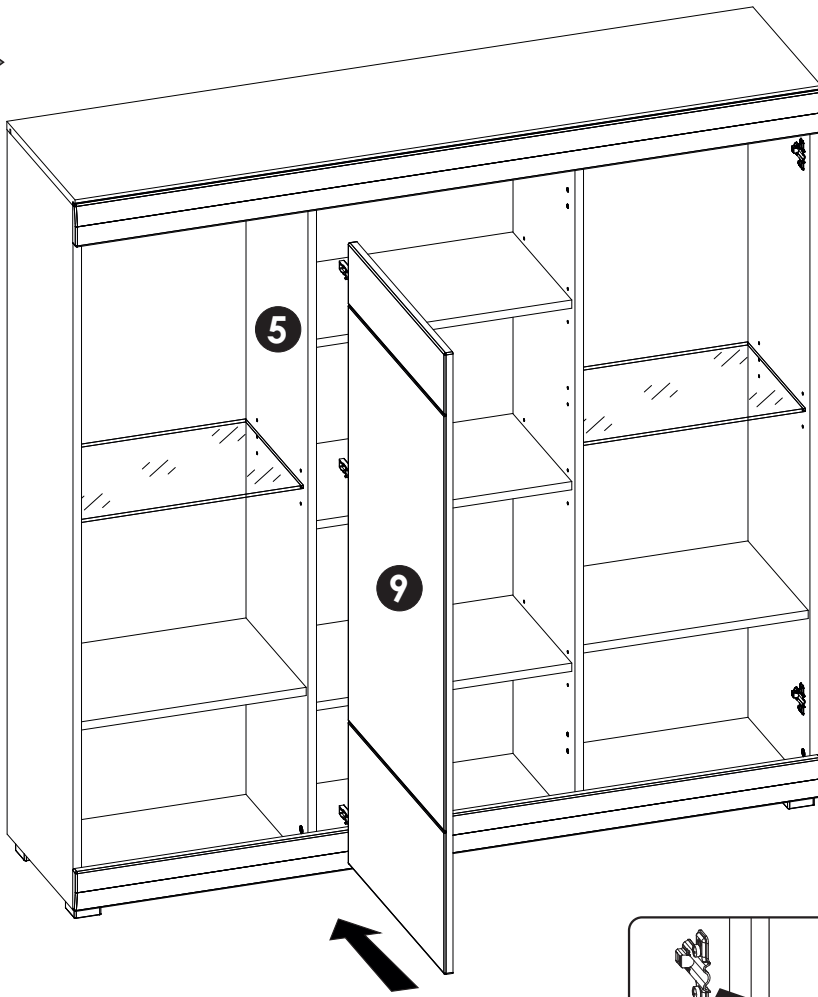

R

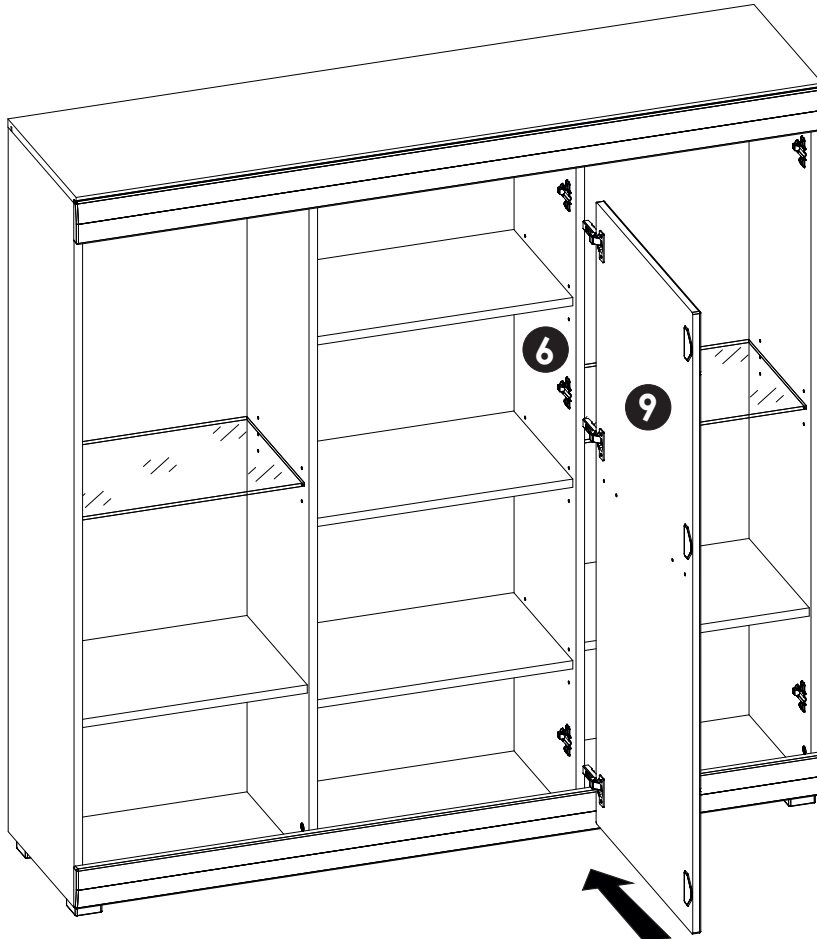

23 ▶

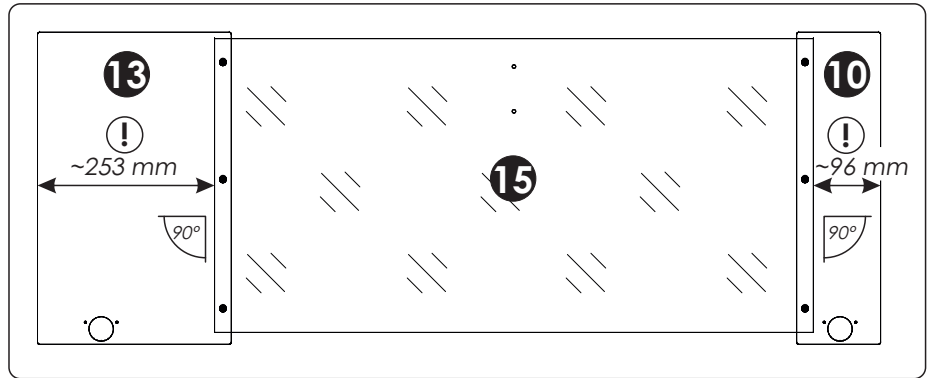
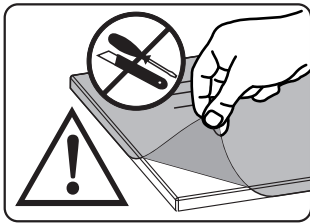
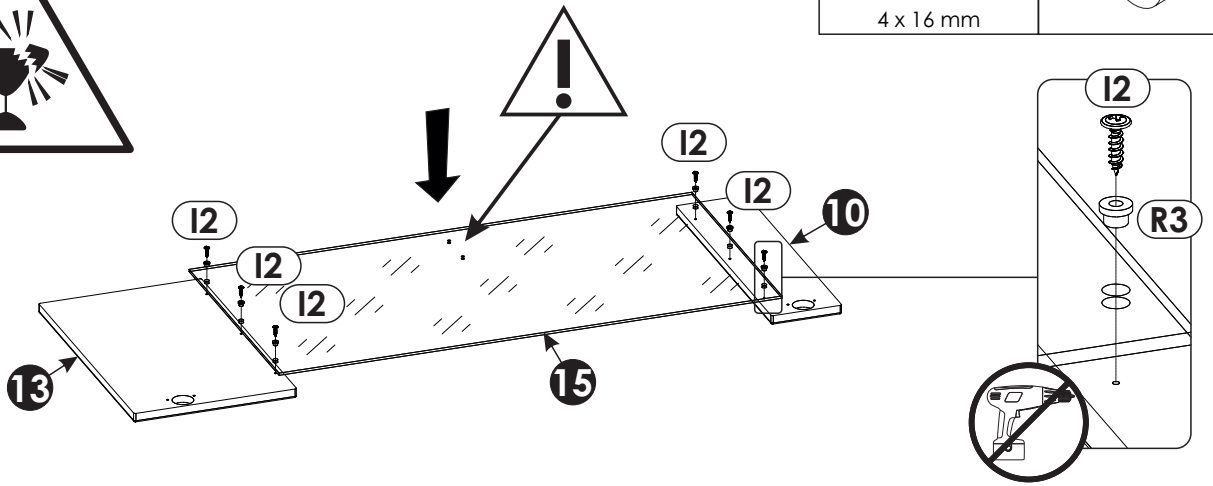
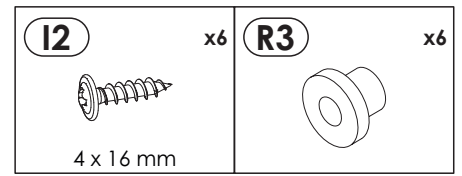

24 ▶

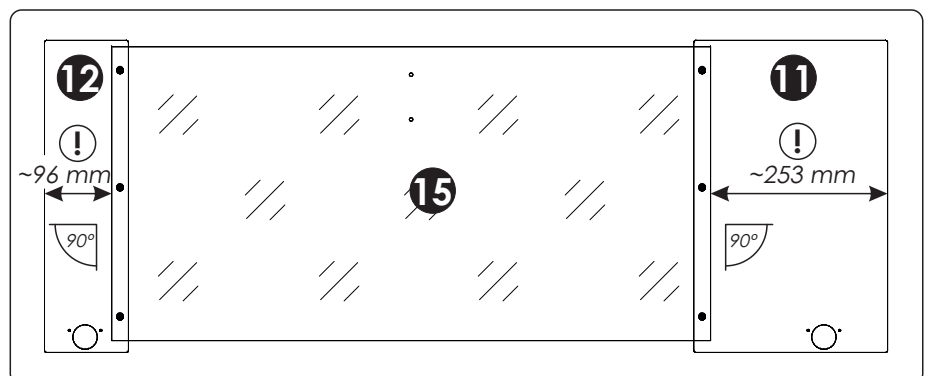
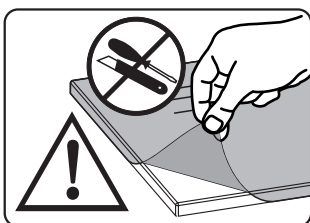
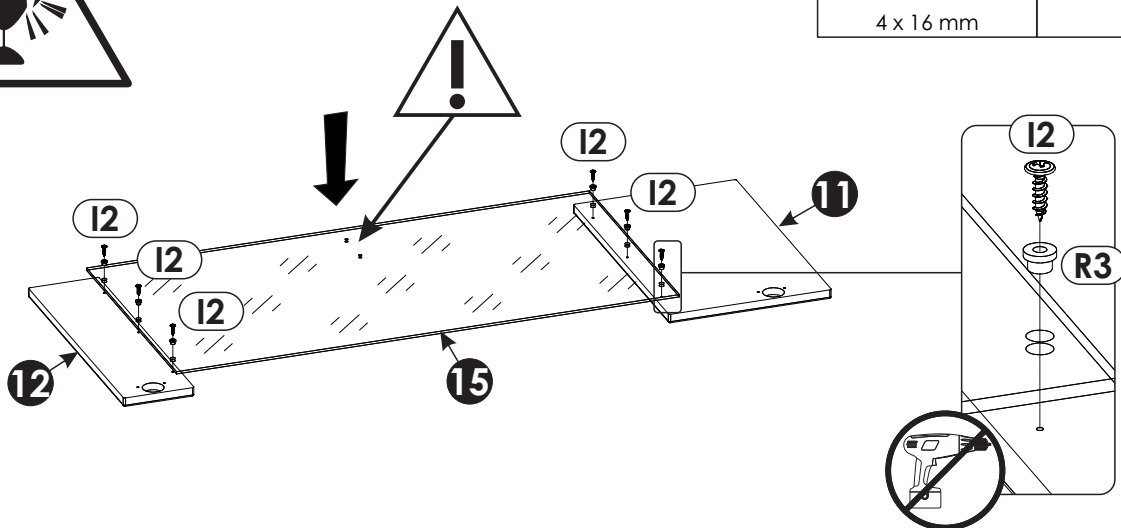
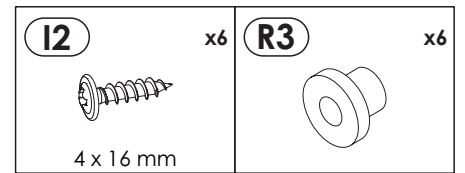

25 ▶

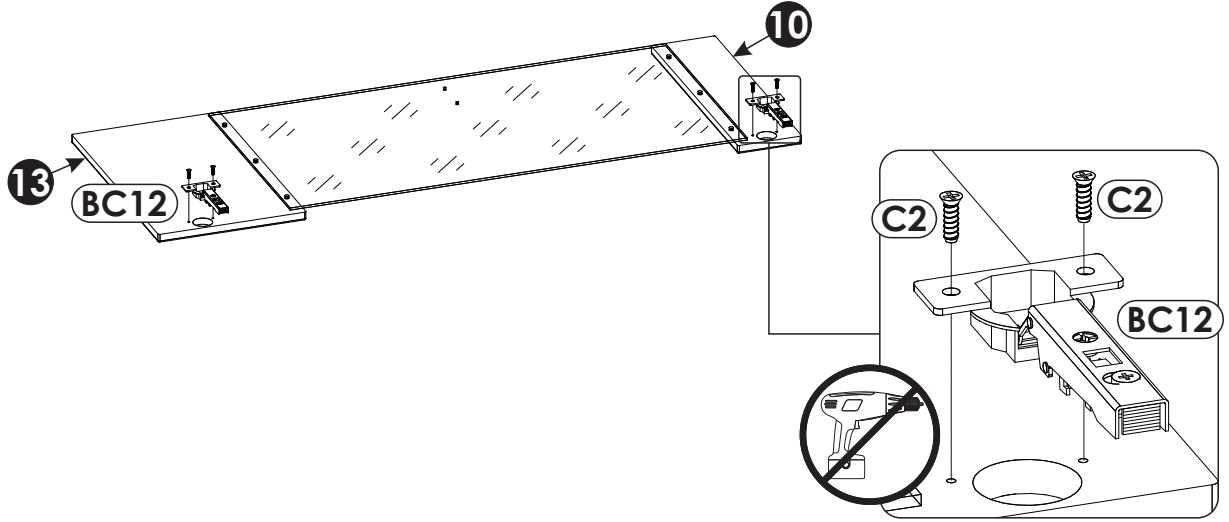
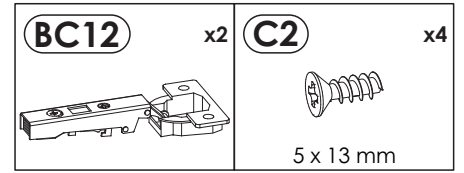
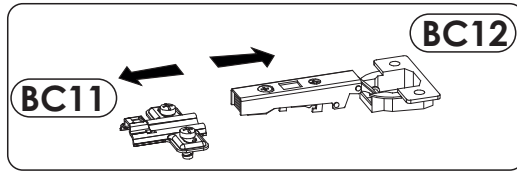

26 ▶

