

Montageanleitung | Kundeninformation Assembly Instructions | Customer information Notice de montage | Information client

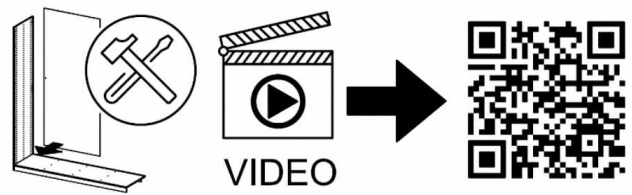

D,CH,AT,LU Wir übernehmen keine Haftung, Garantie und Gewährleistung für Mängel und Schäden, die aus unsachgemäßer Verwendung, falscher Montage sowie durch Nichtbeachtung von Montage- und Anwendungshinweisen entstanden sind.
GB,US We accept no liability and give no guarantee for defects, loss or damage that arise from inappropriate or incorrect use, incorrect or faulty assembly, or failure to comply with assembly and use instructions.
FR,BE,NC Nous déclinons toute responsabilité et toute garantie quant aux défauts et aux dommages, résultant d'une utilisation inadéquate, d'un montage incorrect, ainsi que du non-respect des consignes de montage et d'utilisation.
NL Wij zijn niet aansprakelijk en verlenen geen garantie voor gebreken en schade die terug te voeren zijn op ondeskundig gebruik, verkeerde montage en het negeren van montage- en toepassingsinstructies.
IT Non ci assumiamo alcuna responsabilità né diamo garanzia per difetti e danni dovuti a uso non conforme alla destinazione, a un montaggio sbagliato, così come alla non osservanza delle indicazioni di montaggio e di applicazione.
SI Ne prevzemamo odgovornosti in garancije za napake in škode, nastale zaradi neustrezne uporabe, pomanjkljive montaže ter navodil za montažo in uporabo.
XS,HR,BA Ne preuzimamo odgovornost i jamstvene obveze za nedostatke štete nastale nenamjenskom uporabom, manjkavom montažom kao i nepridržavanjem uputa za montažu i korištenje.
HU Nem vállalunk felelősséget és szavatosságot olyan hibákért és károkért, amelyek nem megfelelő vagy szakszerűtlen használat, nem megfelelő vagy hibás szerelés, valamint a alkalmazási útmutatások figyelmen kívül hagyása miatt keletke
BG Не поемаме отговорност за дефекти и повреди, които са възникнали възникнали поради неподходящо или некомпетентно използване, грешен или неправилен монтаж, както и поради неспазване на указанията за монтаж и
CZ,SK Za vady nebo škody vzniklé v důsledku nevhodného nebo neodborného použití, nesprávné nebo chybné montáže a nedodržení pokynů k montáži a použití nepřebíráme žádné ručení/záruku a neposkytujeme žádné záruční plnění.
SE Vi övertar inget ansvar och garantianspråk för fel och skador som har uppstått genom felaktig användning, felaktig montering, samt genom att monterings- och användaranvisningar inte beaktas.
RO Nu ne asumăm nicio răspundere pentru lipsurile și deteriorările care sunt cauzate de utilizarea neconformă, montajul defectuos, precum și din cauza nerespectării indicațiilor de montaj și de utilizare.
ES No se asume ninguna responsabilidad o garantía por los defectos defectos y daños provocados por un uso inadecuado, por un montaje deficiente o por el incumplimiento de las instrucciones de montaje y aplicación.

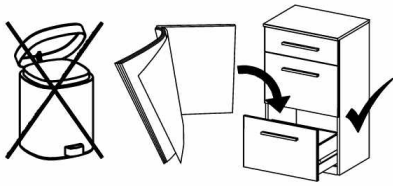
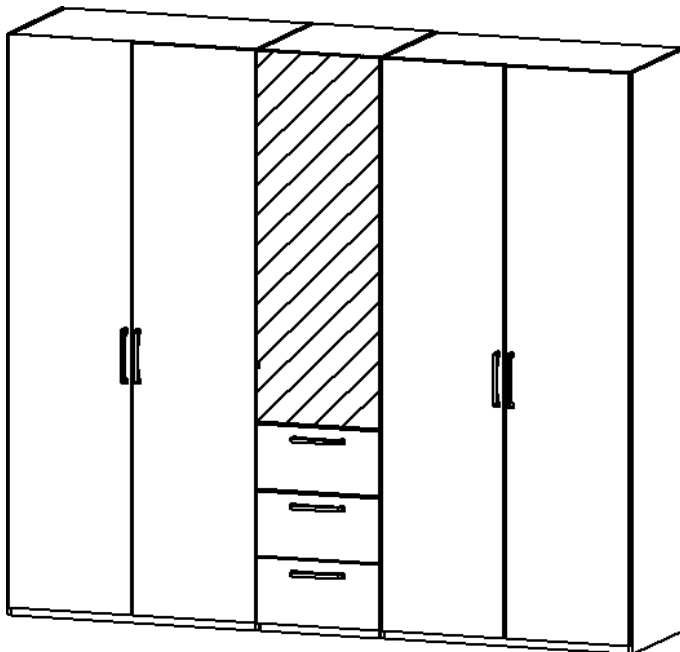

Materialnummer
ADWWA.5932

Montageanleitungen
MD180

Hinweis:

Die individuelle Aufbauanleitung für
das von Ihnen bestellte Produkt
erhalten Sie bei Lieferung der Ware.

Kundeninformation | Customer Information



Informationen zu Garantie-Bedingungen:

www.rauchmoebel.de/garantie-infos

Information on the warranty conditions
Informations concernant la garantie
Informatie over de garantie
Informazioni sulla garanzia
Informacije o garanciji
Informacije o jamstvu
Find garancia feltéleit

Информация за гаранционните условия
Informace ohledně záruky
Informações sobre as condições de garantia
Informații privind garanția
Información sobre la garantía



D CH AT LI LU Kleinteile und Verpackungsfolien von Kindern fernhalten!
GB US Keep small parts and plastic film out of the reach of children!
FR BE NC Tenir les petites pièces et les films plastiques hors de la portée des enfants!
NL Houid de kleine onderdelen en de plastic folie uit de buurt von kinderen!
IT Tenere i componenti di piccole dimensioni e le pellicole di plastica fuori dalla portata dei bambini!
SI Majhnih delov in embalažne folije pri montaži pohištva hranite izven dosega otrok!
XS HR BA Male dijelove i foliju za pakovanje priklom montaže namještaja držite dalje od djece
HU Bűtorszerelés közben a kis alkatrészek és a csomagoló fóliák gyermekektől távol tartandók!
BG Дребни детайли и опаковъчни фолия да се държат далеч от деца при монтажа на мебелите!
CZ SK Při montáži nábytku uchovávejte drobné díly a obalové fólie z dosahu dětí!
PT Mantenha peças pequenas e películas de embalagem afastadas de crianças!
RO Țineți departe de copii piesele mici și folia de ambalat la montarea mobilei!
ES ¡Durante el montaje, mantenga alejados de los niños las piezas pequeñas y el material plástico de embalaje!

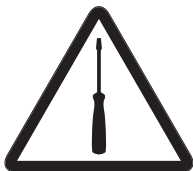

D CH AT LI LU Möbelmontage muss auf ebenem Untergrund erfolgen. Bei Wandmontagen immer geeignetes Befestigungsmaterial verwenden.
GB US Furniture must be assembled on a flat surface. For assembly to the wall only use suitable fixing materials.
FR BE NC Le meuble doit être monté sur une surface plane. Pour le montage mural, utilisez des accessoires de fixation adaptés au type de mur.
NL De meubels dienen op een vlakke ondergrond te worden gemonteerd. Voor wandmontage moeten geschikte bevestigingsmaterialen worden gebruikt.
IT Il montaggio dei mobili deve avvenire su un fondo piano. Per il montaggio si prega di utilizzare solo materiali adatti.
SI Pohištvo je treba montirati na ravni podlagi. Pri stenski montaži vedno uporabite pritrdiveni material.
XS HR BA Namještaj se mora montirati na ravnoj podlozi. Kod montaže na zid uvijek koristite prikladan materijal za pričvršćivanje.
HU A bútorszerelését sők felületen kell végezni. Falra szereléshez mindig megfelelő rögzítanyagot kell használni.
BG Монтажът на мебелите да се извършва на равна основа. При стенен монтаж винаги да се използва подходящ крепежен материал.
CZ SK Montáž nábytku provádějte na rovném podkladu. Při montáži na stěnu používejte vždy vhodný připevňovací materiál.
PT A montagem precisa de ser realizada sobre uma superfície plana. Use sempre material de fixação adequado para montagens em paredes.
RO Montarea mobilei trebuie să se realizeze pe o pardoseală dreaptă. La montarea la perete utilizați întotdeauna material de fixare adecvat.
ES El montaje debe efectuarse sobre una superficie uniforme. En el montaje mural emplee siempre el material de fijación adecuado.



D CH AT LI LU Bitte beachten Sie die Montageanleitung. Halten Sie immer die angegebene Wattzahl ein. Verhindern Sie einen Hitzestau.
GB US Please observe the assembly instructions. Do not exceed the max. given wattage. Ensure that the heat is not allowed to build up.
FR BE NC Veuillez respecter la notice de montage. Respectez impérativement le nombre des watts maximal. Veillez à éviter toute accumulation de chaleur.
NL Lees a.u.b. de montagehandleiding door. Houid u beslist aan het max. opgegeven wattage. Zorg ervoor dat geen hittestuwung onstaat.
IT Attenersi alle istruzioni di montaggio. Rispettarsi rigorosamente il numero di watt max. indicato. Assicurarsi che non si verifichi un accumulo di calore.
SI Upoštevajite navodila za montažo. Vedno upoštevajite navedeno število vatov. Preprečite zastoj vročine.
XS HR BA Obratite molimo Vas pozor na uputu za montažu. Uvijek se pridržavajte navedenog broja vati. Izbjegavajte zastoj vrućine.
HU Vegye figyelembe a szerelési útmutatót. Mindig tartsa be a megadott wattszámot. Akadályozza meg a hőtorlódat.
BG Моля, вземете под внимание ръководството за монтаж. Спазвайте винаги посочените ватове. Избягвайте акумулиране на топлина.
CZ SK Dodržujte prosím návod k montáži. Vždy dodržujte uvedenou hodnotu výkonu (watt). Zabráňte tak přehřívání.
PT Por favor observe o manual de montagem. Respeite sempre a energia em watts indicada. Evite uma acumulação de calor.
RO Respectați instrucțiunile de montaj. Respectați întotdeauna numărul de wați impus. Evitați acumularea de căldură.
ES Le rogamos que tenga presente las instrucciones de montaje. Respete siempre el número indicado de vatios. Evite la acumulación de calor.



D CH AT LI LU Halten Sie die max. zulässigen Belastungswerte der Möbelteile ein. Details siehe Montageanleitung und <https://qrco.de/rauch-belastungstabelle>.
GB US Comply with the max. permissible loads. For details, please refer to the assembly instructions or find at qrco.de/rauch-belastungstabelle.
FR BE NC Respectez les valeurs de charge max. admissibles des parties de meubles. Pour plus de détails, cf. la notice de montage et qrco.de/rauch-belastungstabelle.
NL Houid de maximaal geoorloofde belastingswaarden van de meubeldelen aan. Voor details verwijzen wij naar de montagehandleiding en qrco.de/rauch-belastungstabelle.
IT Rispettare la portata max. permessa degli elementi del mobile. Per dettagli si vedano le istruzioni di montaggio e si vada al sito qrco.de/rauch-belastungstabelle.
SI Upoštevajite največjo dovoljeno obremenitev delov pohištva. Podrobnosti najdete v navodilih za montažo in na qrco.de/rauch-belastungstabelle.
XS HR BA Pridržavajte se maks. dozvoljenih vrijednosti opterećenja elemenata namještaja. Detalje vidí u uputu za montažu i pod qrco.de/rauch-belastungstabelle.
HU Tartsa be a bútorelemek max. megengedett terhelési értékeit. A részleteket lásd a szerelési útmutatóban és a qrco.de/rauch-belastungstabelle.
BG Спазвайте макс. допустимите стойности на натоварване на мебелите. За подробности виж ръководството за монтаж и qrco.de/rauch-belastungstabelle.
CZ SK Dodržujte max. přípustné hodnoty zatížení nábytkových dílů. Podrobnosti viz návod k montáži a qrco.de/rauch-belastungstabelle.
PT Respeite os valores de carga máx. permitidos dos componentes dos móveis. Consulte detalhes no manual de montagem e em qrco.de/rauch-belastungstabelle.
RO Respectați valorile de solicitare max. admise pentru corpurile de mobilier. Pentru detalii consultați instrucțiunile de montaj și adresa de internet qrco.de/rauch-belastungstabelle.
ES Respete los valores máximos de carga admisibles para las piezas de los muebles. Consulte los detalles en las instrucciones de montaje y en qrco.de/rauch-belastungstabelle.



D CH AT LI LU Zur Möbelreinigung ein mit Wasser befeuchtetes, fusselfreies Baumwolltuch verwenden. Gereinigte Flächen immer trockenreiben!
GB US To clean the furniture only use a water dampened lint-free cotton cloth. Once cleaned, always wipe the surfaces dry.
FR BE NC Utilisez un chiffon en coton non pelucheux humidifié avec de l'eau pour nettoyer les meubles. Séchez systématiquement les surfaces nettoyées en les frottant !
NL Gebruik een met water bevochtigde, pluivrije katoenen doek om de meubels te reinigen. Wrijf gereinigde oppervlakken altijd droog!
IT Per pulire il mobile utilizzare un panno di cotone inumidito d'acqua e che non perde pelucchi. Asciugare sempre le superfici che si sono pulite!
SI Za čiščenje pohištva uporabljajte vlažno bombažno krpo, ki ne pušča vlaken. Očiščene površine vedno obrišite do suhega!
XS HR BA Za čišćenje namještaja koristite sa vodom navlaženu pamučnu krpu koja ne ispušta vlakna. Očišćene površine uvijek obrišite suhom krpom!
HU Bűtorisztításhoz vízzel benedvesített, nem szálasodó pamutkendőt használjon. A megtisztított felületeket mindig törölje szárazra!
BG За почистване на мебелите използвайте навлажнена с вода, неизпускаща влакна памучна кърпа. Почистените повърхности винаги да се изтрият до сухо!
CZ SK K čištění nábytku používejte bavlněný hadr neuvolňující vlákna, navlhčený ve vodě. Vyčištěné plochy vždy utřete do sucha!
PT Para limpar os móveis, use um pano de algodão que não largue pelo, humedecido com água. Seque sempre bem as superfícies limpas com um pano!
RO Pentru curățarea mobilei utilizați o lavetă din bumbac fără scame umezită cu apă. Suprafețele curățate se șterg întotdeauna până se usucă!
ES Emplee un paño de algodón humedecido con agua y libre de pelusa para la limpieza de los muebles. ¡Seque siempre las superficies que ha limpiado!

D CH AT LI LU Эту информацию на других языках вы найдете по адресу
GR CY Αυτές τις πληροφορίες θα τις βρείτε και σε άλλες γλώσσες εδώ
TR Bu bilgileri diğer dillerde buradan ulaşabilirsiniz
MK На други јазици, овие информации можете да ги најдете на
PL Te informacje sa dostępne w dalszych językach na stronie
SE Dessa information ett annat språk finns på
DK Disse oplysninger findes på flere sprog under



www.rauchmoebel.de/gbh

IT: Etichettatura Ambientale - www.rauchmoebel.de/etichettatura



Ihre Meinung ist uns wichtig!

Liebe Kundin, lieber Kunde,

vielen Dank für Ihre Bestellung und herzlichen Glückwunsch zum Erwerb dieses Möbelstücks. Neben seinem modernen Design und seiner Funktionalität legen wir großen Wert auf die hochwertige Verarbeitung und Langlebigkeit unserer rauch Produkte. Unsere Produkte werden in umweltschonenden Prozessen hergestellt und unterliegen strengen Qualitätskontrollen, um sicherzustellen, dass sie den aktuellen Standards für Gesundheit und Nachhaltigkeit entsprechen. „Made in Germany“ ist für uns nicht nur eine Herkunftsbezeichnung, sondern eine Verpflichtung zur Qualität und eine Herzensangelegenheit.

Wir produzieren unsere Möbel seit jeher in Deutschland, setzen dabei modernste Technologien ein und bringen unsere langjährige Erfahrung und Leidenschaft ein. **Wir würden uns freuen, wenn Sie uns weiterempfehlen und eine Produktrezension bei Ihrem Händler schreiben könnten.** Ihre Meinung ist uns wichtig, und sie kann anderen Kunden bei ihrer Kaufentscheidung helfen.

Vielen Dank im Voraus für Ihre Unterstützung!



Your feedback matters!

Dear Customer

Thank you for your order and congratulations on your new piece of furniture. Beyond modern design and functionality, we place great importance on the high-quality craftsmanship and durability of our rauch products. Our furniture is manufactured using environmentally friendly processes and undergoes rigorous quality checks to ensure it meets the latest health and sustainability standards.

For us, „Made in Germany“ is more than just a label of origin; it is a commitment to quality and a cause close to our hearts. We have always produced our furniture in Germany, combining state-of-the-art technology with our many years of experience and passion. **We would be delighted if you could recommend us and leave a product review with your retailer.** Your feedback is incredibly important to us and can help other customers make an informed choice.

Thank you in advance for your support!

Votre avis nous intéresse !

Chère cliente, cher client,

Nous vous remercions de votre commande et vous félicitons pour l'achat de ce meuble. Outre son design moderne et sa fonctionnalité, nous accordons une grande importance à la qualité de fabrication et à la durabilité de nos produits rauch. Nos produits sont fabriqués selon des procédés respectueux de l'environnement et sont soumis à des contrôles de qualité stricts afin de garantir leur conformité aux normes actuelles normes en matière de santé et de durabilité.

Pour nous, « Made in Germany » ce n'est pas seulement une indication d'origine, mais aussi un engagement envers la qualité et une affaire de cœur. Nous produisons nos meubles depuis toujours en Allemagne, en utilisant les technologies les plus modernes et en mettant à profit notre longue expérience et notre passion. **Nous serions ravis que vous nous recommandiez et que vous laissiez un avis sur le produit chez votre revendeur.** Votre avis est important pour nous et peut aider d'autres clients dans leur décision d'achat.

Merci d'avance pour votre soutien !

Liebe Kundin, Lieber Kunde,

neue Einrichtungsgegenstände haben in der Regel einen Eigengeruch, der abhängig von der Produktionscharge, was Geruchsintensität und Geruchseindruck angeht, unterschiedlich ausgeprägt sein kann. Von einigen Menschen wird der Geruch als unangenehm empfunden oder ruft gar gesundheitliche Bedenken hervor. Bei Möbeln, die mit dem Umweltzeichen „Blauer Engel DE-UZ 38 Emissionsarme Möbel und Lattenroste aus Holz und Holzwerkstoffen“ ausgezeichnet sind, können Sie sicher sein, dass mit keinen gesundheitlichen Beeinträchtigungen zu rechnen ist. Die Anforderungen des Umweltzeichens finden Sie unter: www.blauer-engel.de. Leider können Möbelgerüche nicht einfach weggewischt werden, da sich die Geruchsquelle (Holzwerkstoffe, Beschichtungsstoffe) weiterhin im Wohnraum befindet. Der Geruch wird jedoch über einen nicht vorhersehbaren Zeitraum schleichend abnehmen und schließlich nicht mehr wahrnehmbar sein. Dies ist dann der Fall, wenn die Geruchsstoffe im Material selbst soweit abgebaut sind, dass die persönliche Geruchsschwelle unterschritten wird.



Tipp:

Generell wird empfohlen, größere Einrichtungsgegenstände vor dem Aufbau auszupacken und gut belüftet, für ca. 1 Woche, ausdünsten zu lassen.



Dear Customer,

It is quite common for new furniture to have a distinct „new“ scent. Depending on the specific production batch, the intensity and nature of this smell can vary. We appreciate that for some, this scent can be more noticeable and may lead to perceived concerns regarding wellbeing. However, please be assured that for furniture carrying the „Blue Angel“ (Blauer Engel DE-UZ 38) eco-label for low-emission furniture and slatted frames made of wood and wood-based materials, there are no associated health risks. This certification guarantees that the products meet strict safety standards. For further details on these environmental requirements, please visit: www.blauer-engel.de. Unfortunately, furniture odours cannot simply be „wiped away,“ as the source (such as the wood-based materials or coatings) remains in the room. That said, the scent will gradually fade over an unpredictable period until it is no longer noticeable. This occurs once the compounds within the material have dissipated to a level below the individual's scent threshold.



Tip:

As a general rule, we recommend unpacking larger items and allowing them to air out in a well-ventilated space for about a week before final assembly.

Chère cliente, cher client,

Les nouveaux meubles ont généralement une odeur propre qui, selon le lot de production, peut varier en termes d'intensité et d'impression olfactive. Certaines personnes trouvent cette odeur désagréable, voire préoccupante pour la santé. Pour les meubles certifiés par le label écologique « Blauer Engel DE-UZ 38 Meubles et sommiers à lattes à faibles émissions en bois et matériaux dérivés du bois », vous pouvez être sûr qu'ils ne présentent aucun risque pour la santé. Vous trouverez les exigences du label écologique sur : www.blauer-engel.de. Malheureusement, les odeurs des meubles ne peuvent pas être simplement éliminées, car la source de l'odeur (matériaux dérivés du bois, revêtements) se trouve toujours dans la pièce. Cependant, l'odeur diminuera progressivement sur une période imprévisible et finira par ne plus être perceptible. Ce sera le cas lorsque les substances odorantes présentes dans le matériau lui-même se seront décomposées au point de passer en dessous du seuil olfactif personnel.



Conseil:

Il est généralement recommandé de débiller les meubles de grande taille avant de les monter et de les laisser s'aérer dans une pièce bien ventilée pendant environ une semaine.

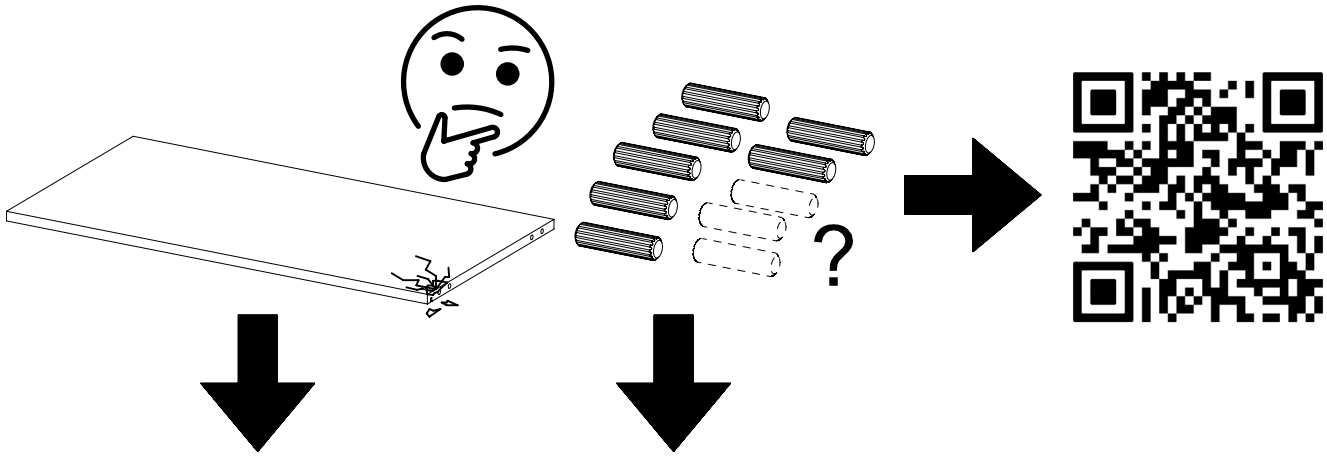

Bitte melden Sie sich bei Beanstandungen mit folgenden Informationen bei Ihrem Möbelhändler.
 If you have any complains, please contact your furniture retailer with the following information.

Rauch Möbelwerke GmbH • Wendelin-Rauch-Straße 1 • D-97896 Freudenberg/Main
www.rauchmuebel.de

Montageanleitung | Kundeninformation
Assembly Instructions | Customer information
Notice de montage | Information client

VIDEO

0003 A6380

64570 00007 00207

Ladefolge 64570 00007 laufende Nr. 00207

Fertigungsdatum 09.02.2023
 Werk 0003
 Arbeitsplatz/Id. Nr. A6380 / 443
 Materialnummer A971B.645R
 Kundenbuchnr. 48460537
 Menge 1

Montageanleitungen MZ610 MZ044

10x	1189	4x	130
8x	227	4x	251
4x	568	4x	1000
16x	1002	8x	1003
4x	1105	4x	1187
10x	1188	10x	18

Kundenauftrag	Materialnummer	Montageanleitung	Bildnummer	Anzahl
Customer order	Material number	Assembly instruction	Part No.	Quantity

! Bitte fügen Sie diesem Formular Fotos bei ! Please provide photos with this form !

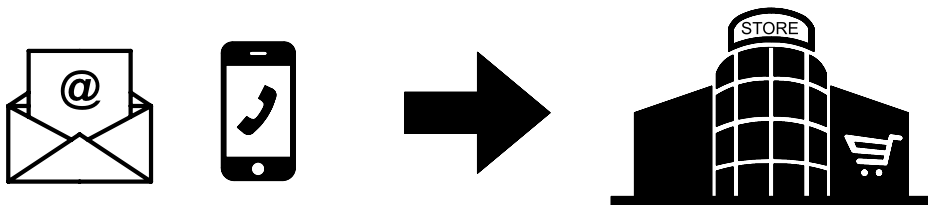



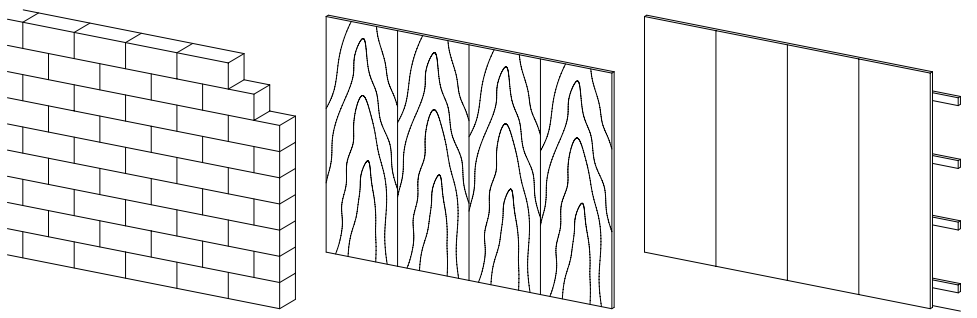
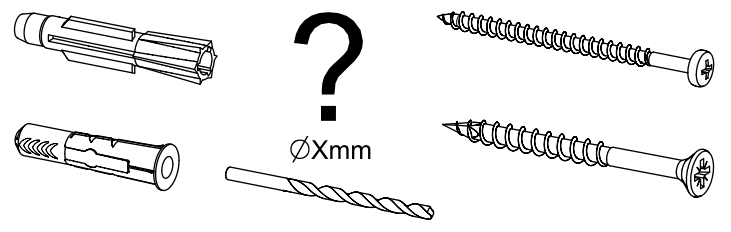
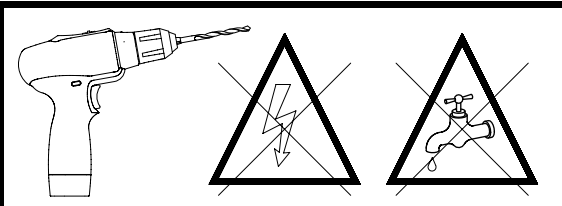
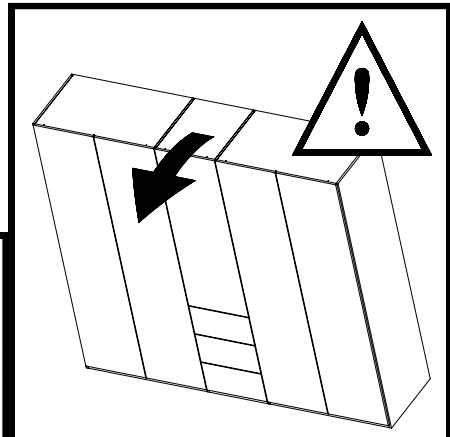
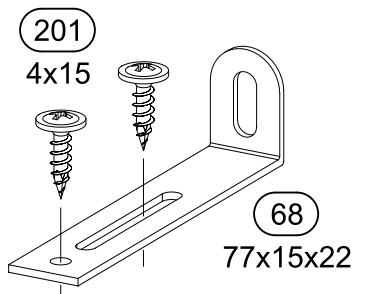
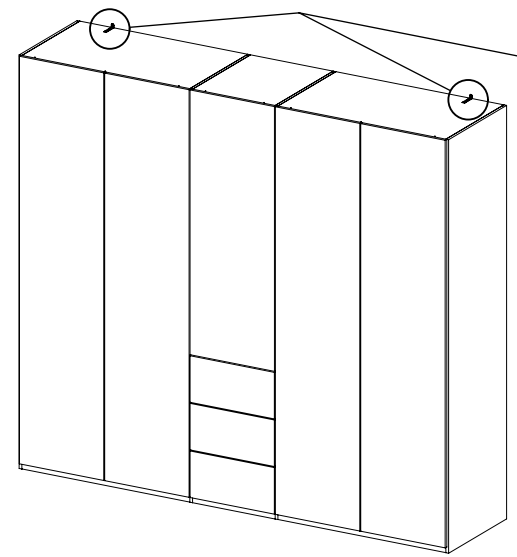
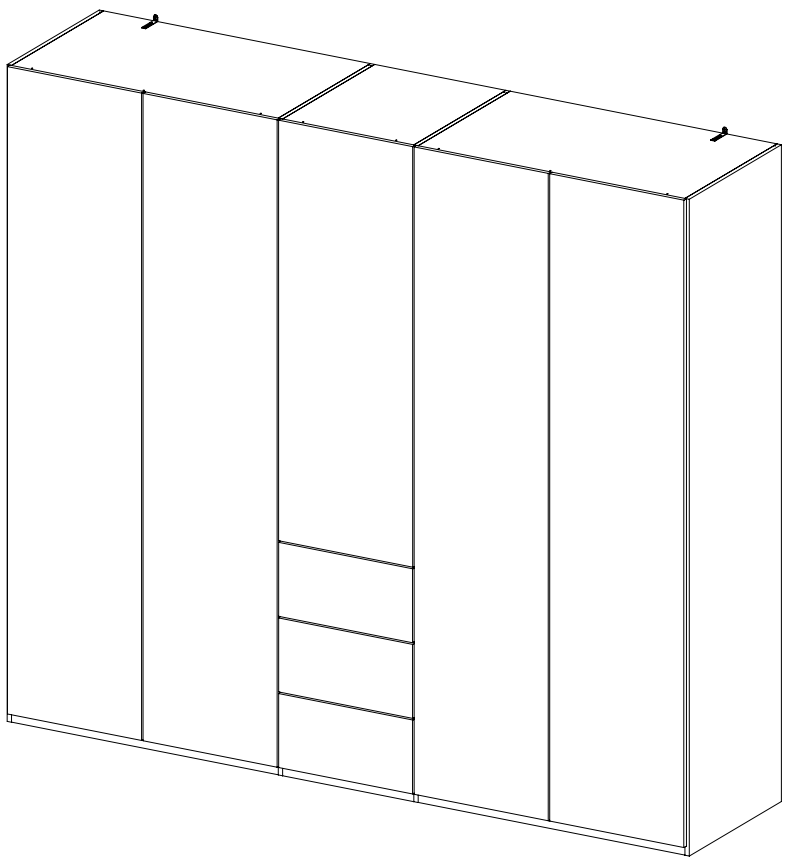
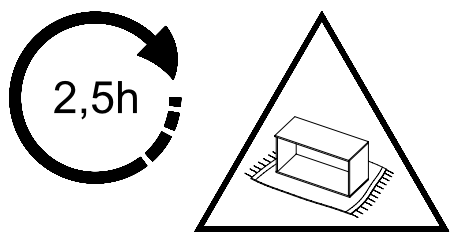
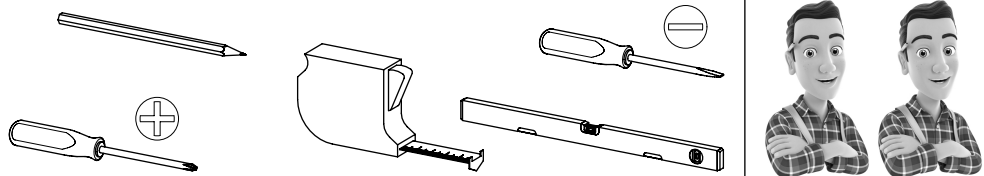





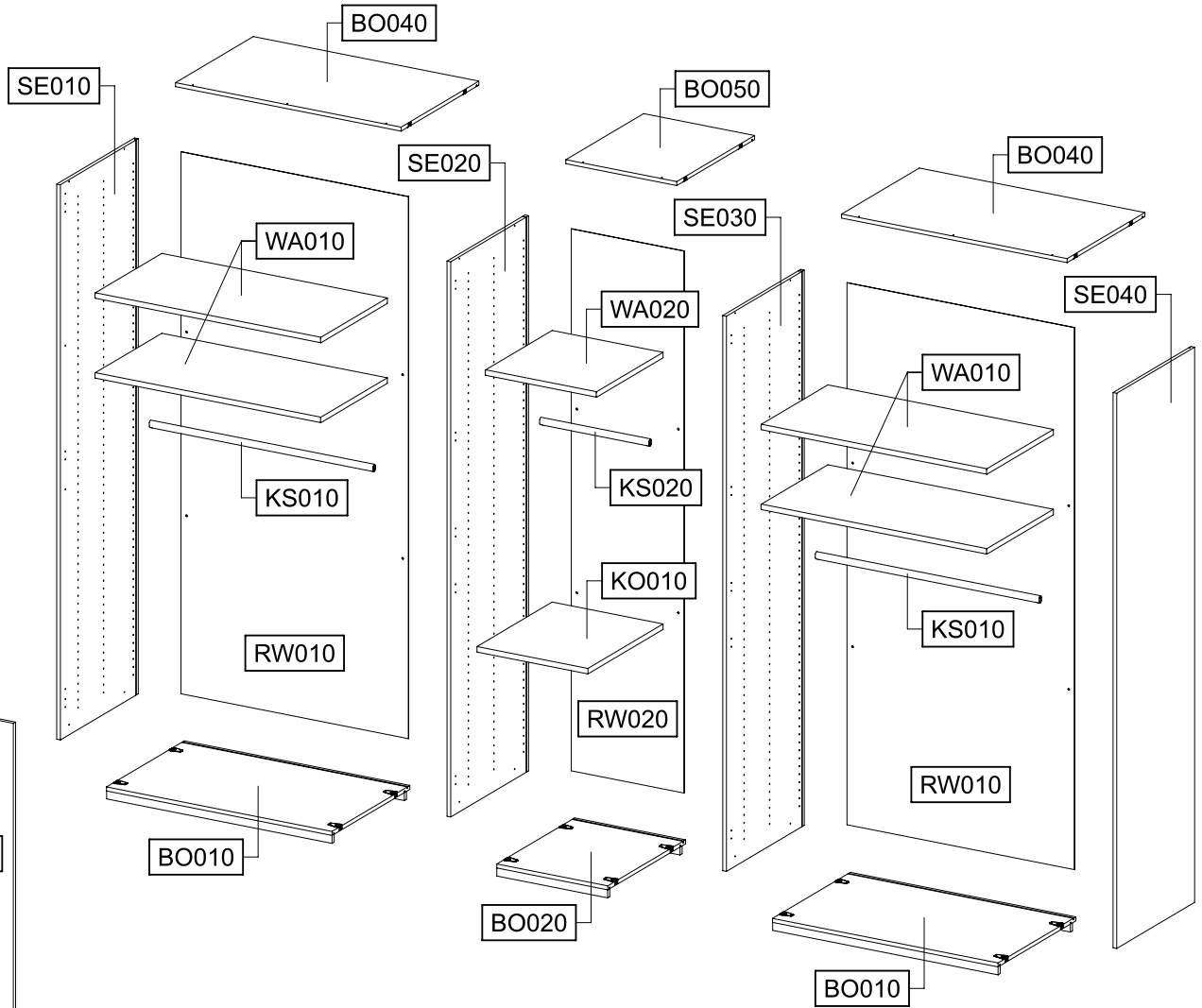
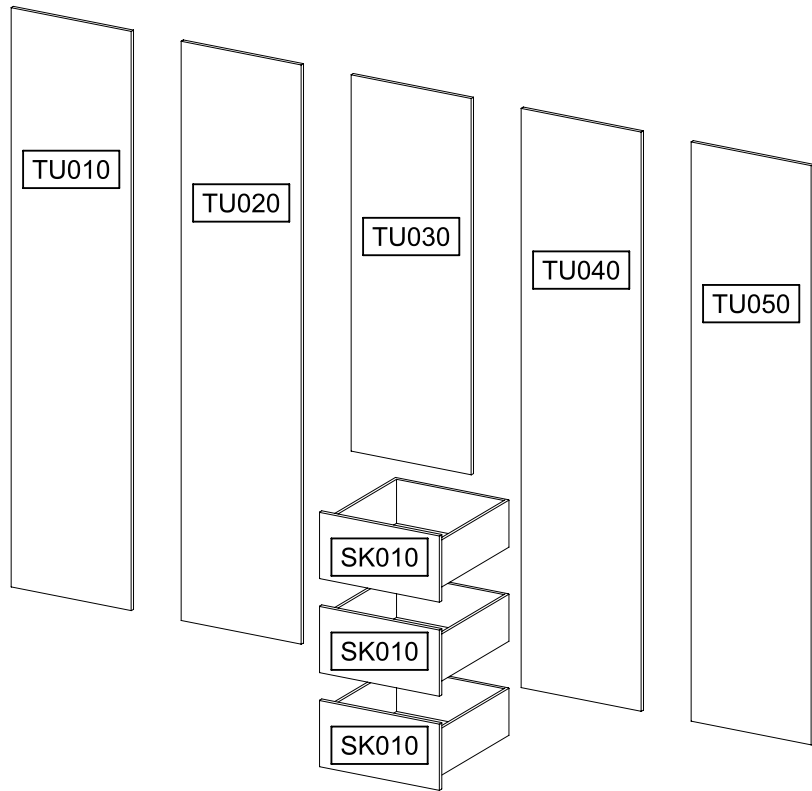

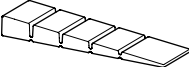
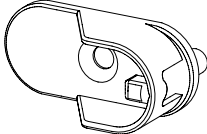

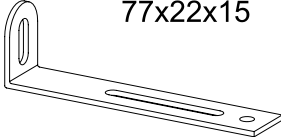
MD180_02



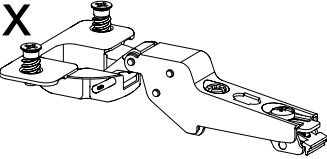

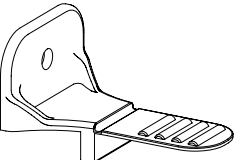

SE020 = SE030

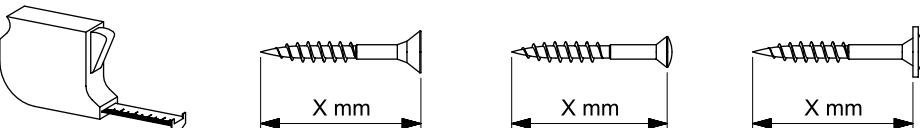

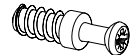
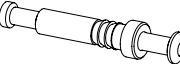
<p>0-9x 55x16x6,2</p> <p>(12) </p>	<p>6x</p> <p>(29) </p>
<p>12x</p> <p>(47) </p>	<p>2x 77x22x15</p> <p>(68) </p>
<p>5x 4x15</p> <p>(201) </p>	<p>6x 3,5x15</p> <p>(205) </p>
<p>2x</p> <p>(1301) </p>	<p>15-19x</p> <p>(1291) </p>
<p>15-19x</p> <p>(1292) </p>	<p>30-38x 4x13</p> <p>(621) </p>
<p>1x</p> <p>(775) </p>	<p>12x 6,5x12</p> <p>(779) </p>
<p>12x 6,3x9</p> <p>(792) </p>	<p>12x 4x15</p> <p>(836) </p>
	

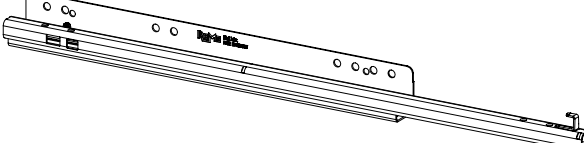
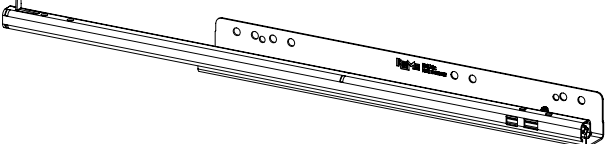
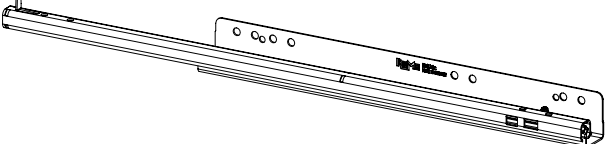
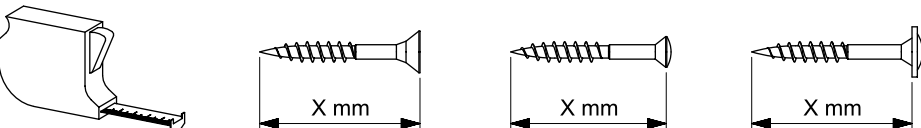
<p>6x</p> <p>(852) </p>	<p>8x</p> <p>(1085) </p>
<p>8x</p> <p>(1086) </p>	<p>24x</p> <p>(1089) </p>
<p>3x</p> <p>UF010 </p>	
<p>3x</p> <p>UF020 </p>	
<p>3x</p> <p>UF020 </p>	
	

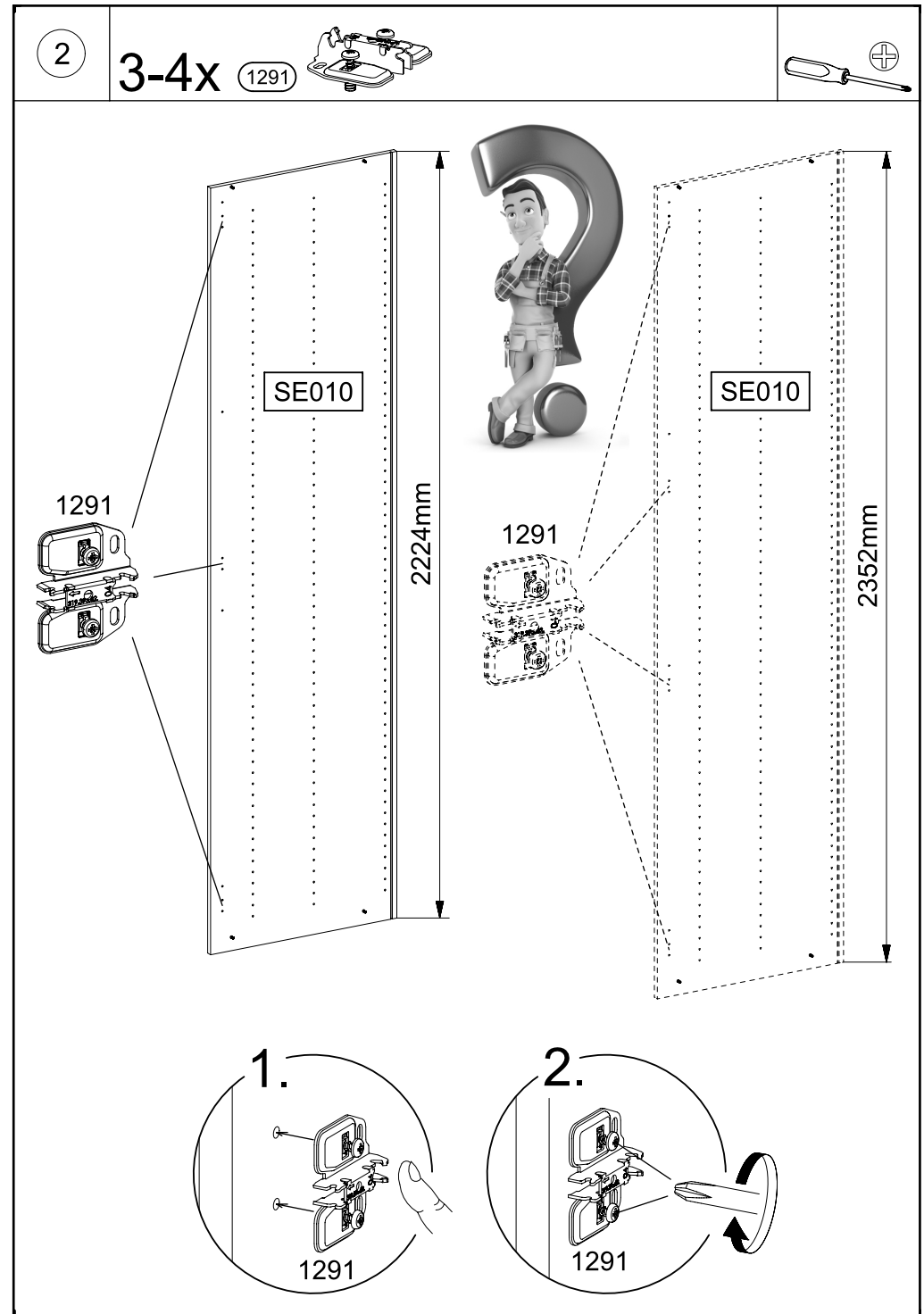
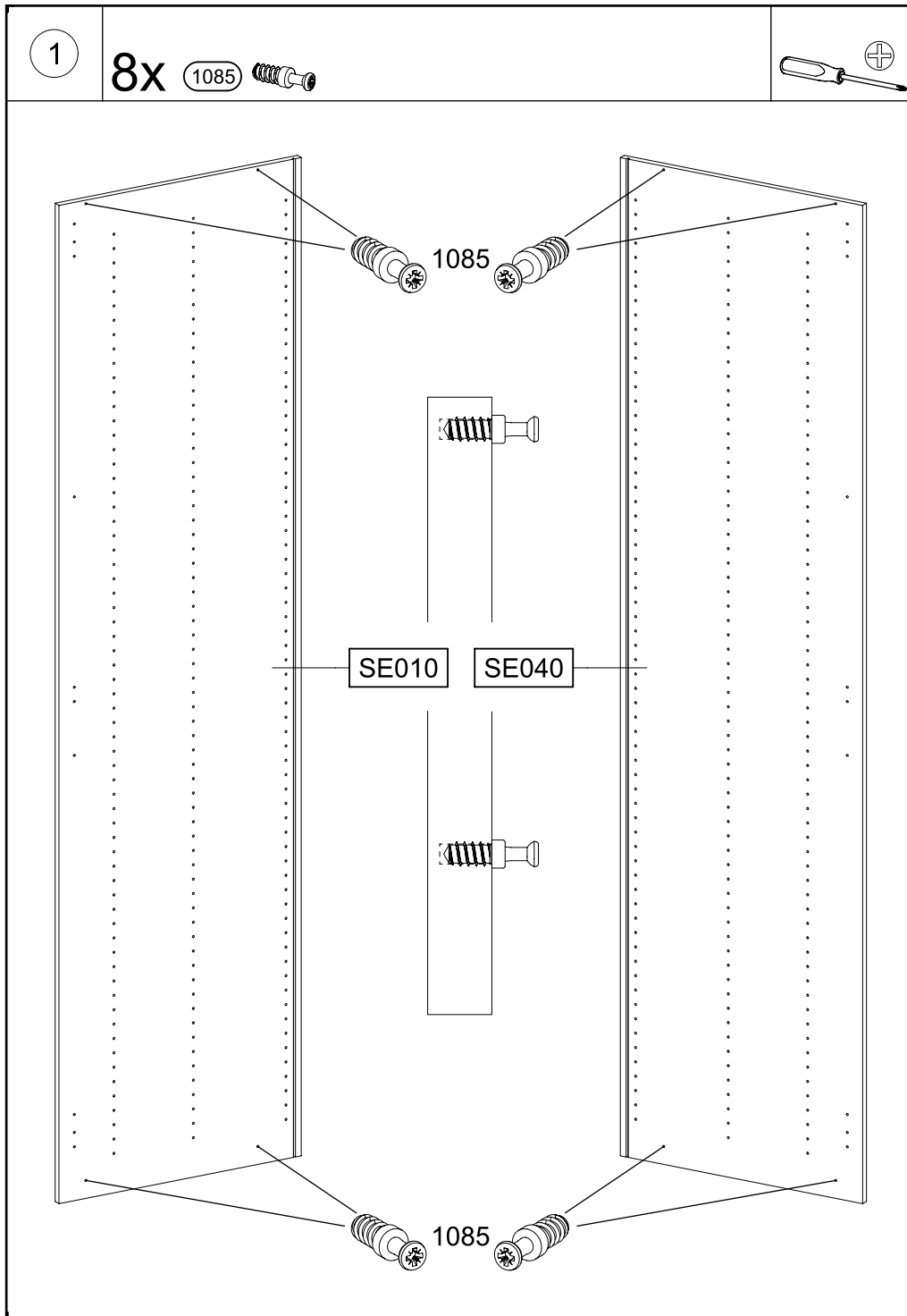

3

3-4x 1291

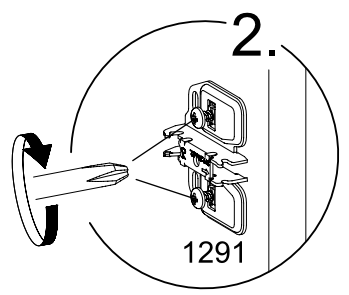
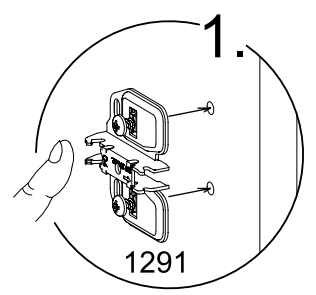
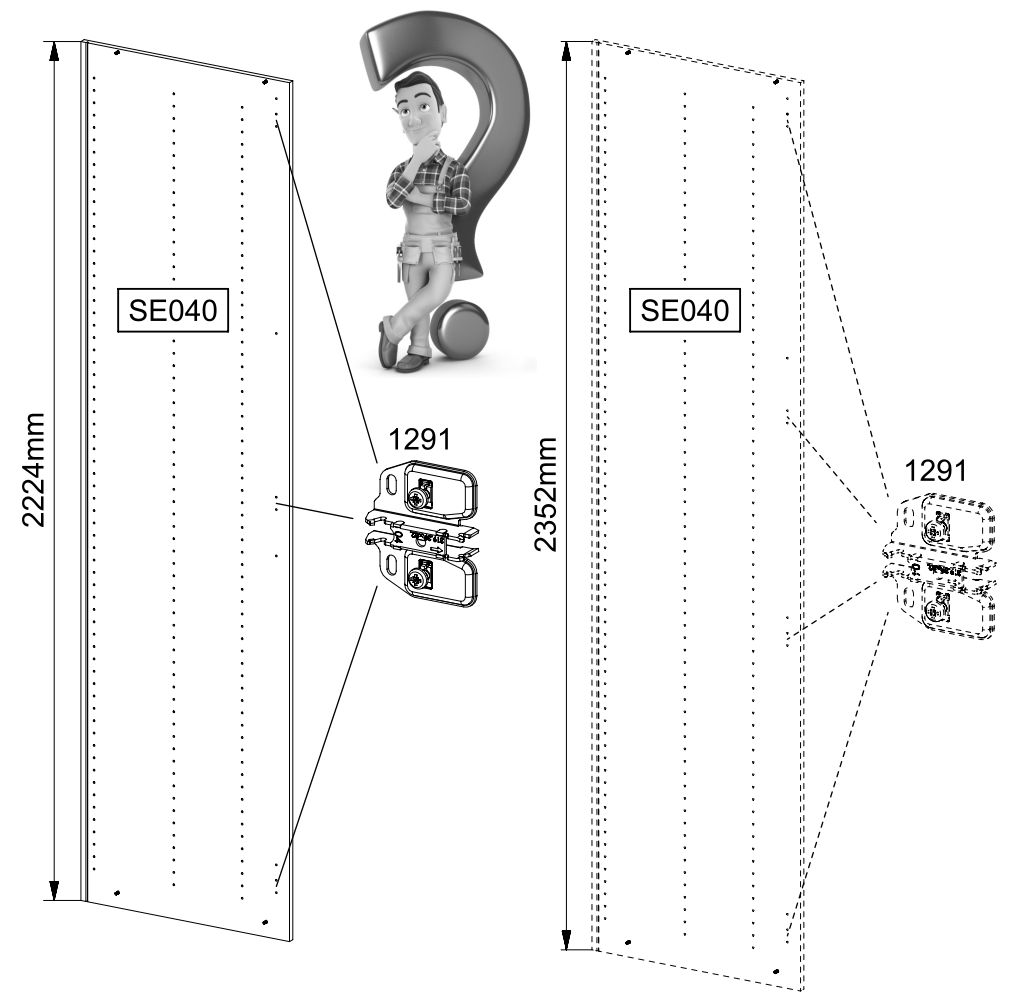
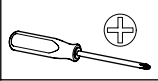
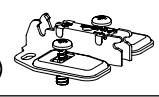

4

8x 1086

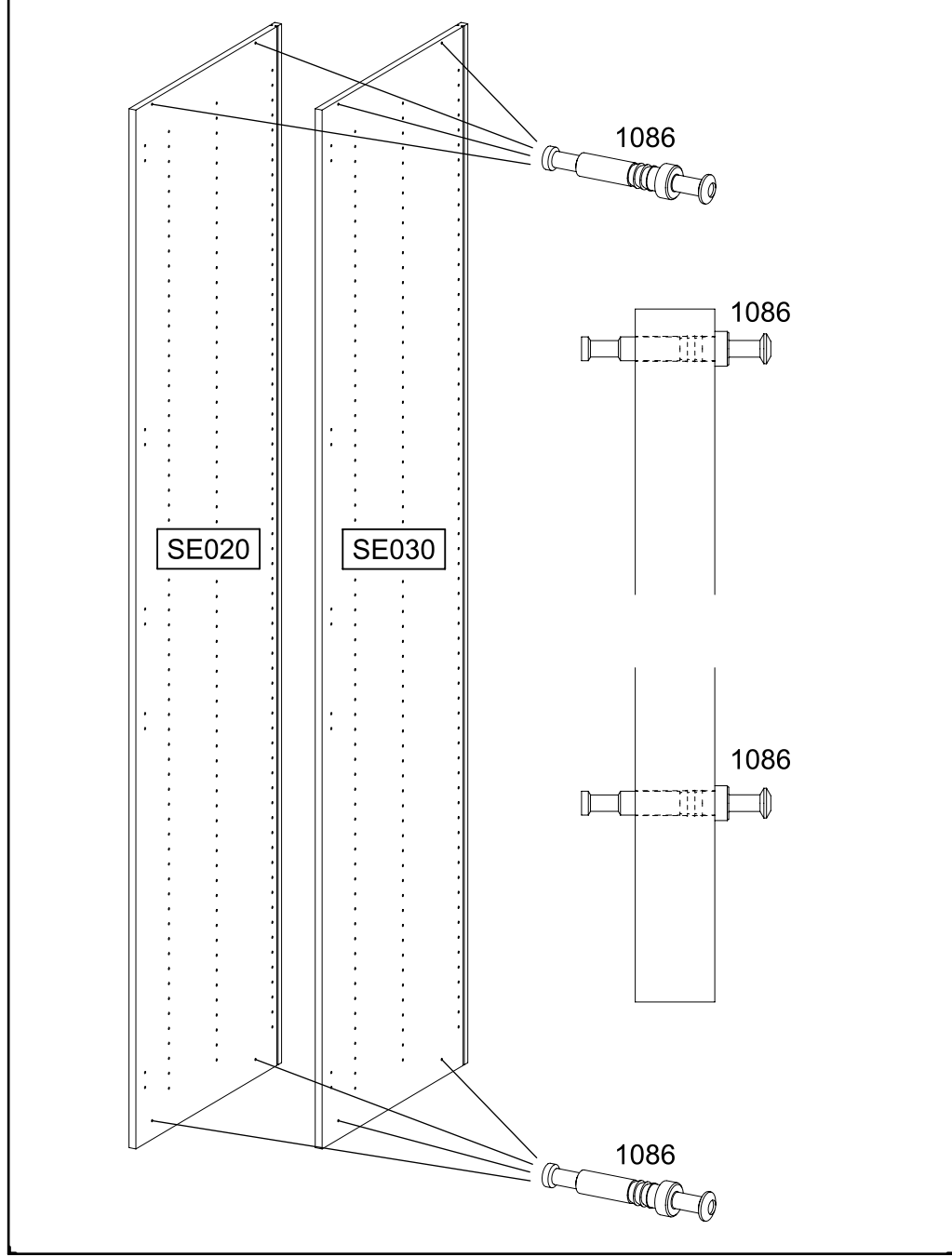
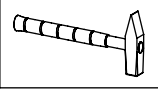
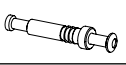

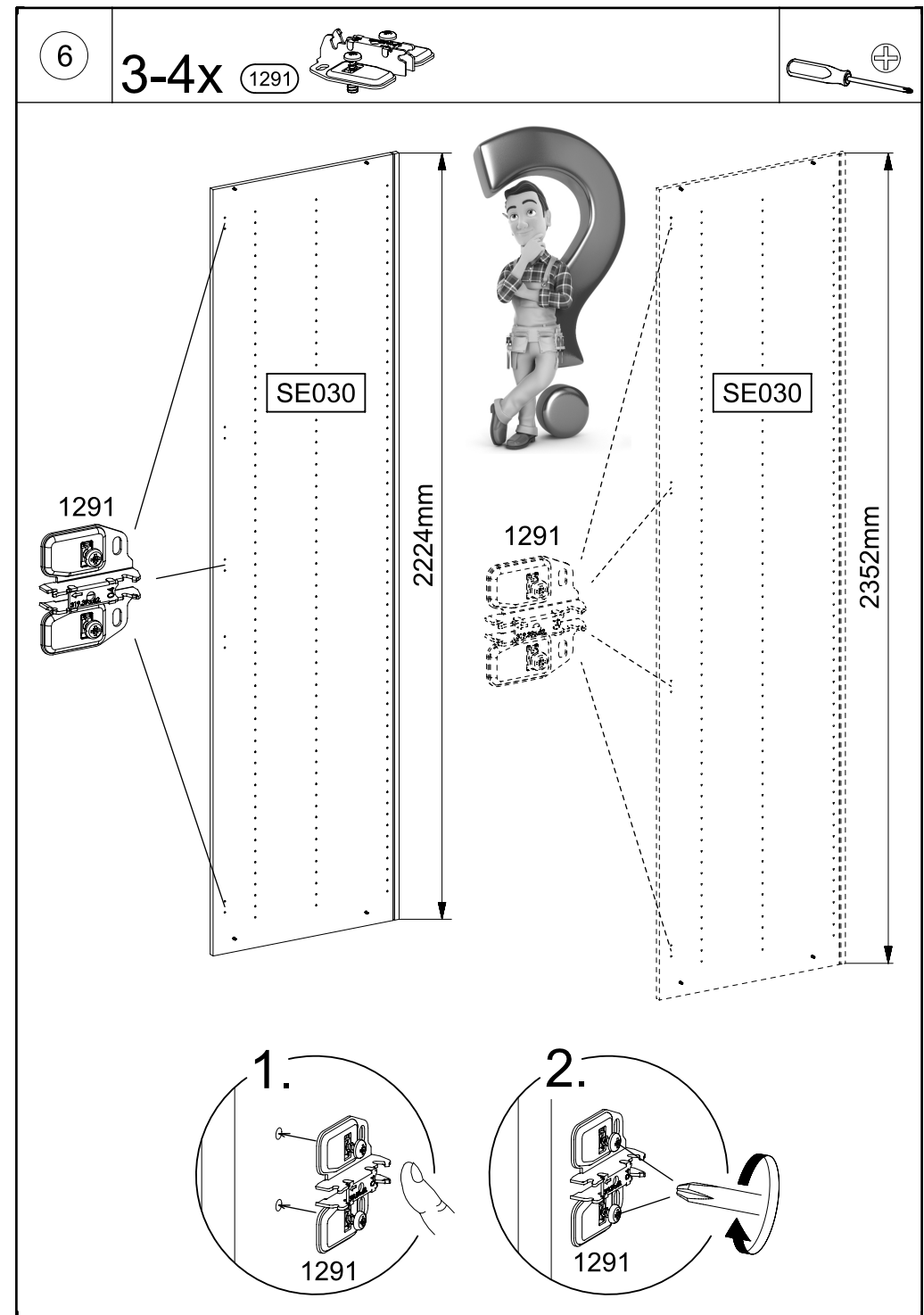
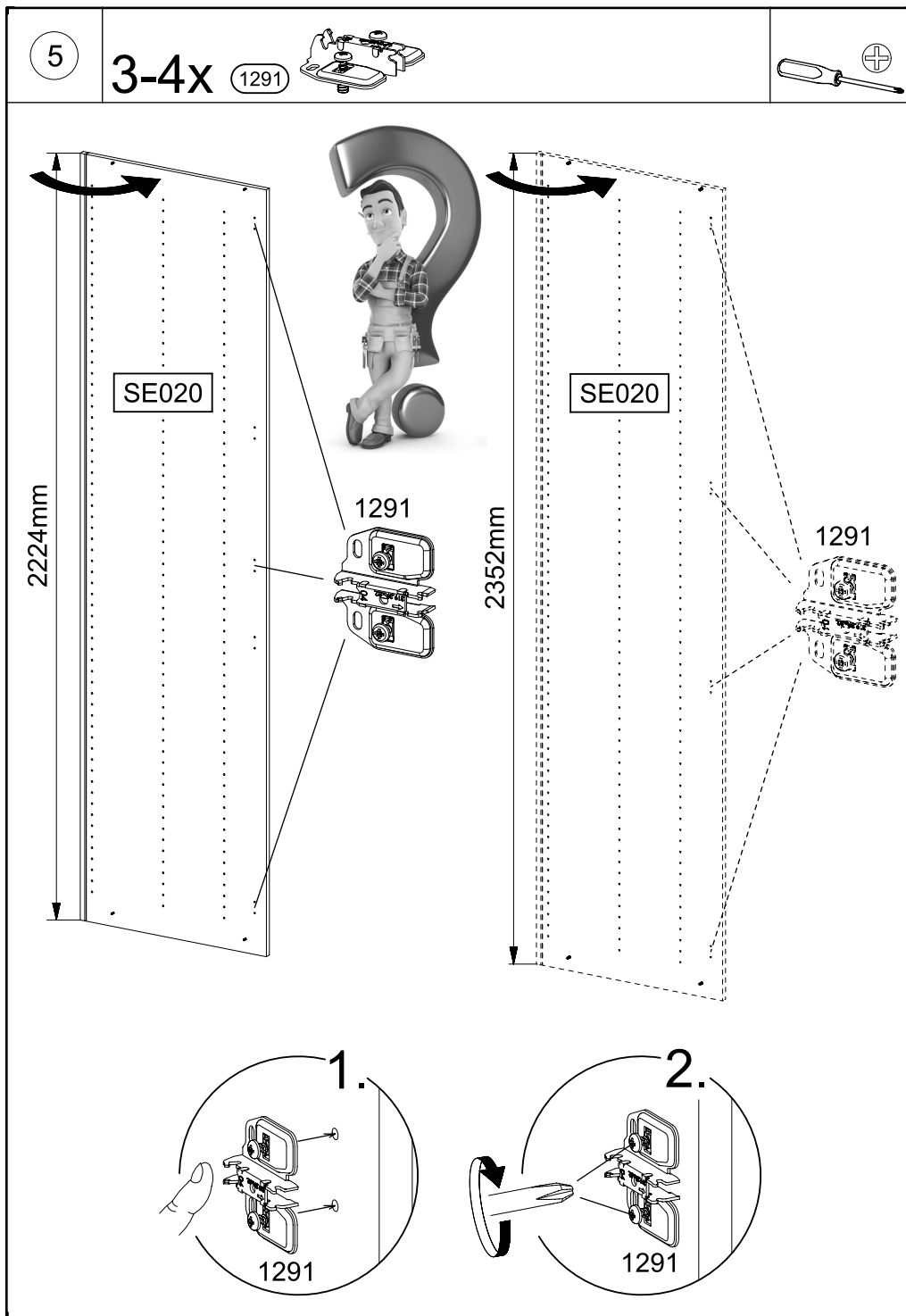

7

3x 1291

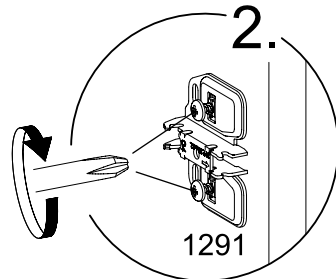
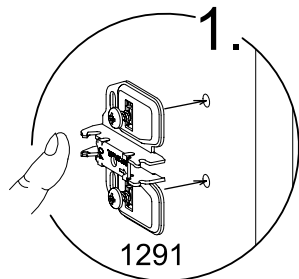
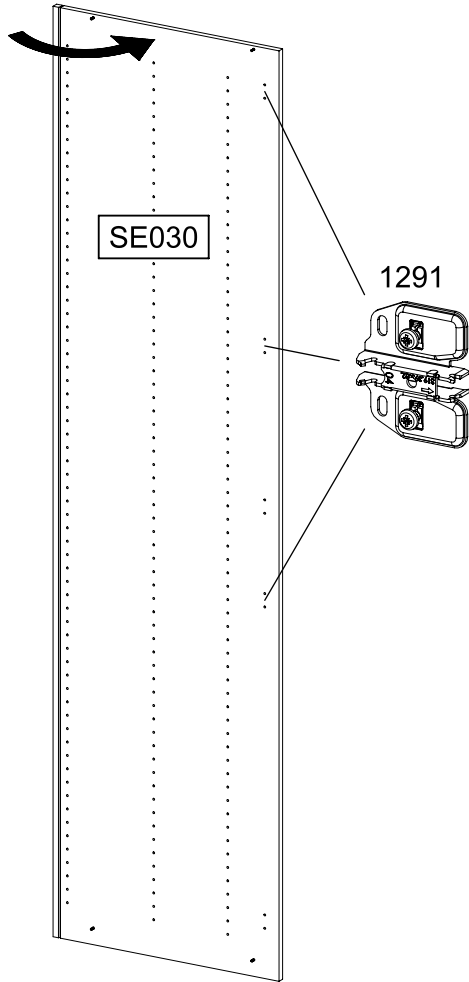
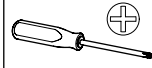

8

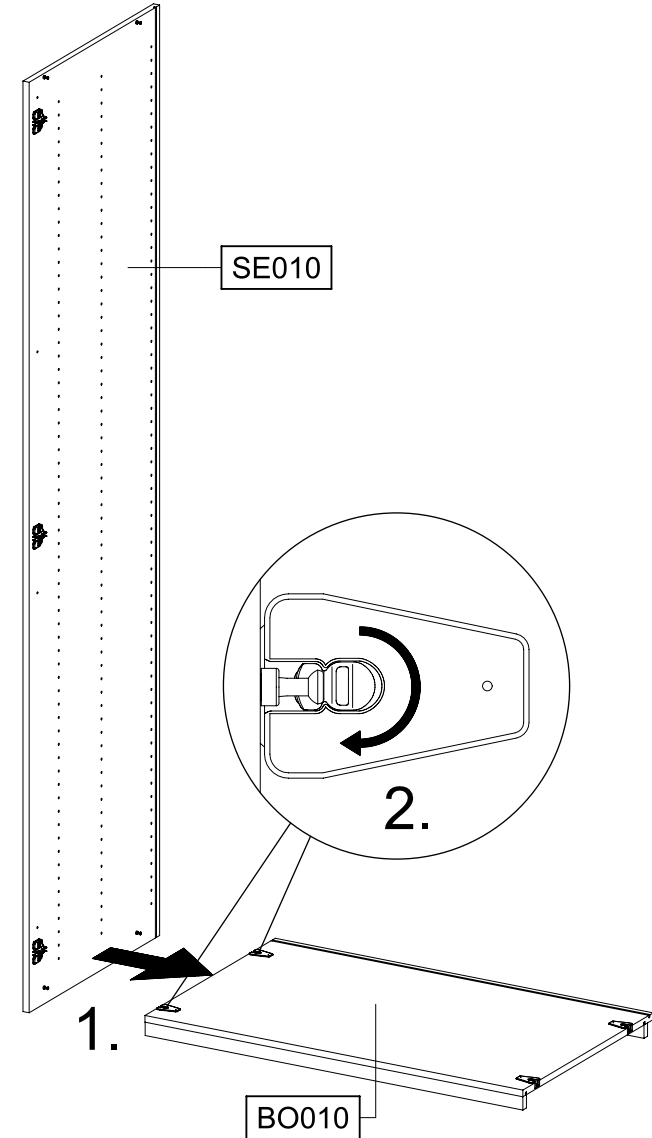
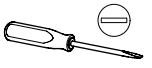

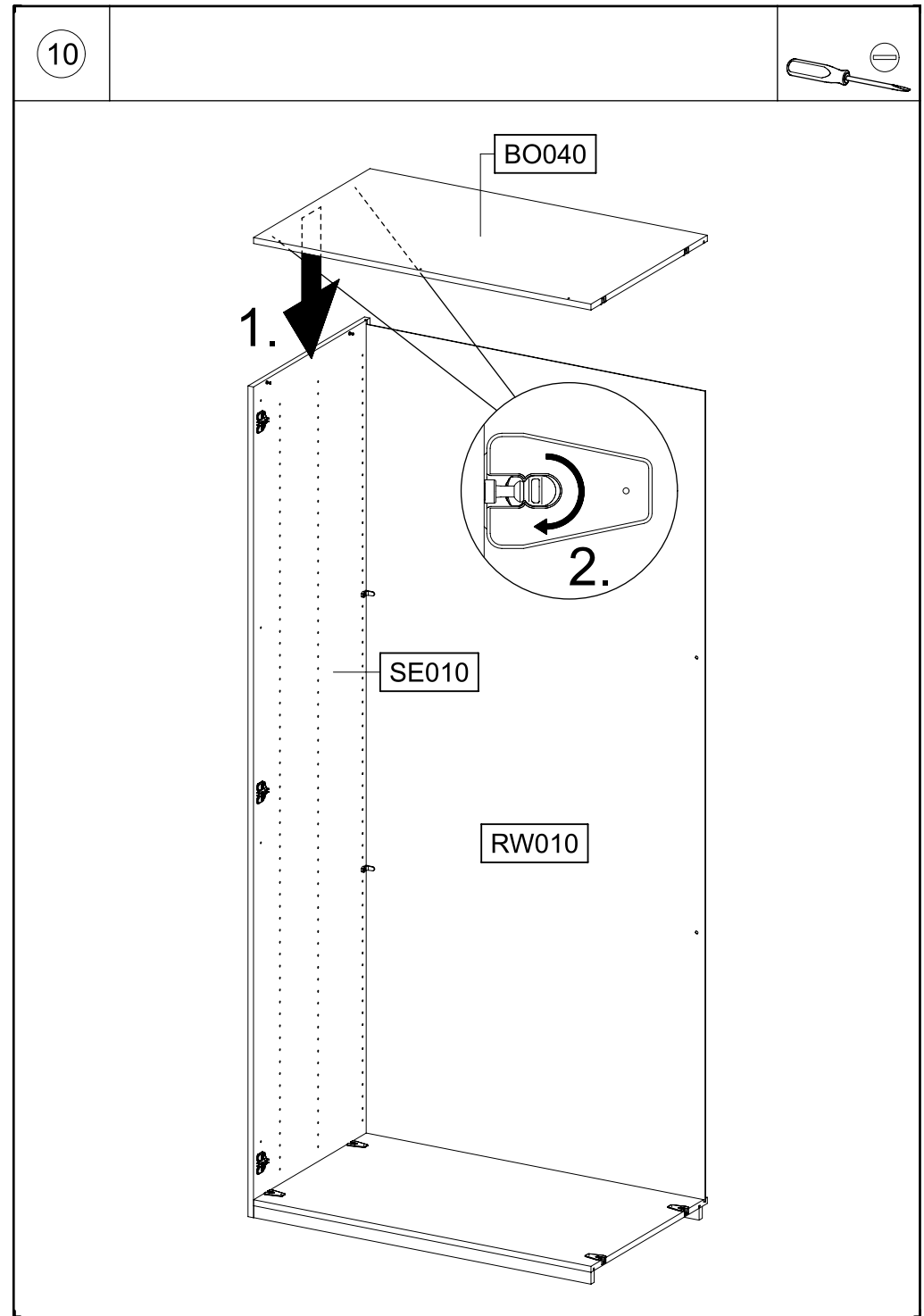
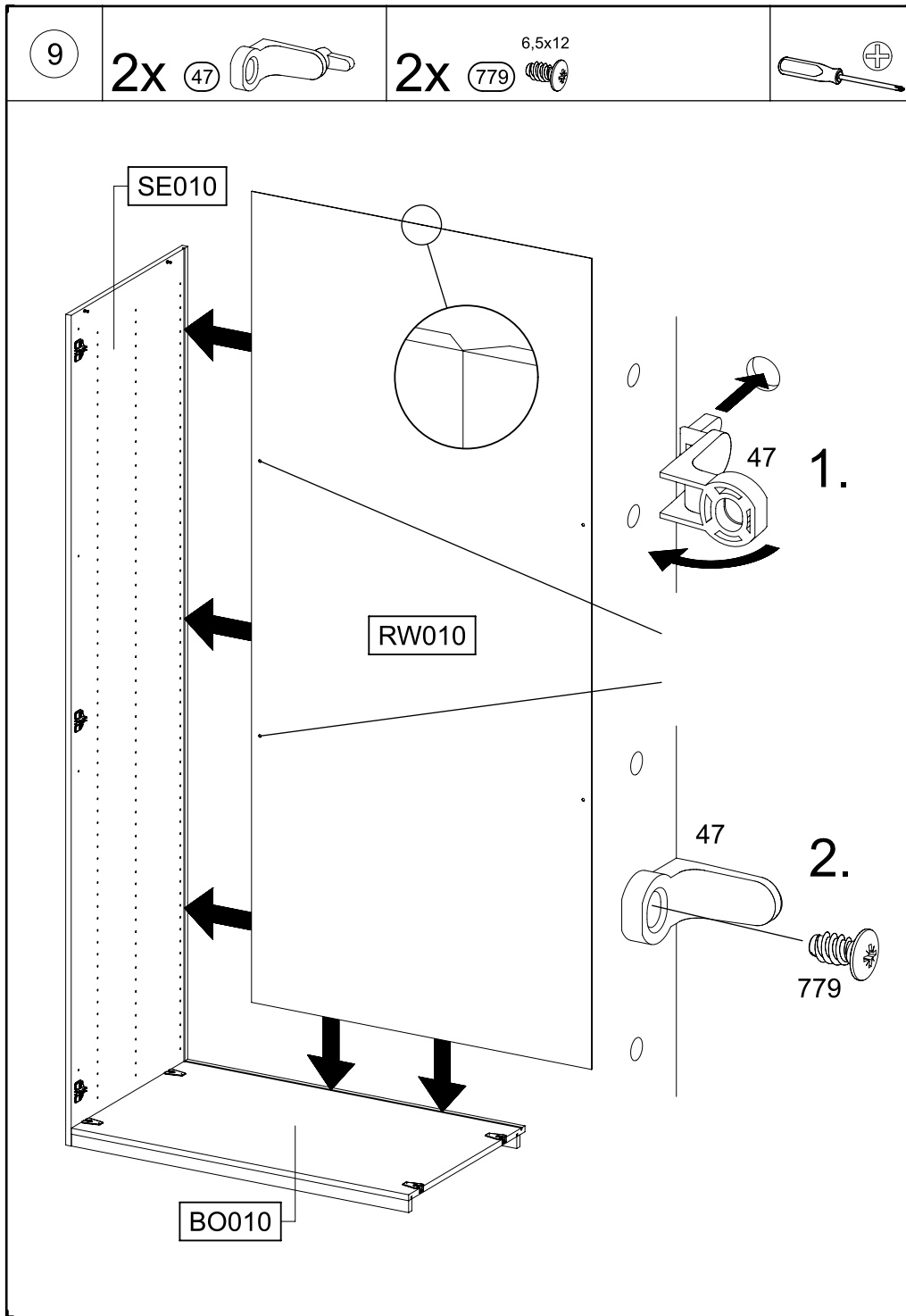

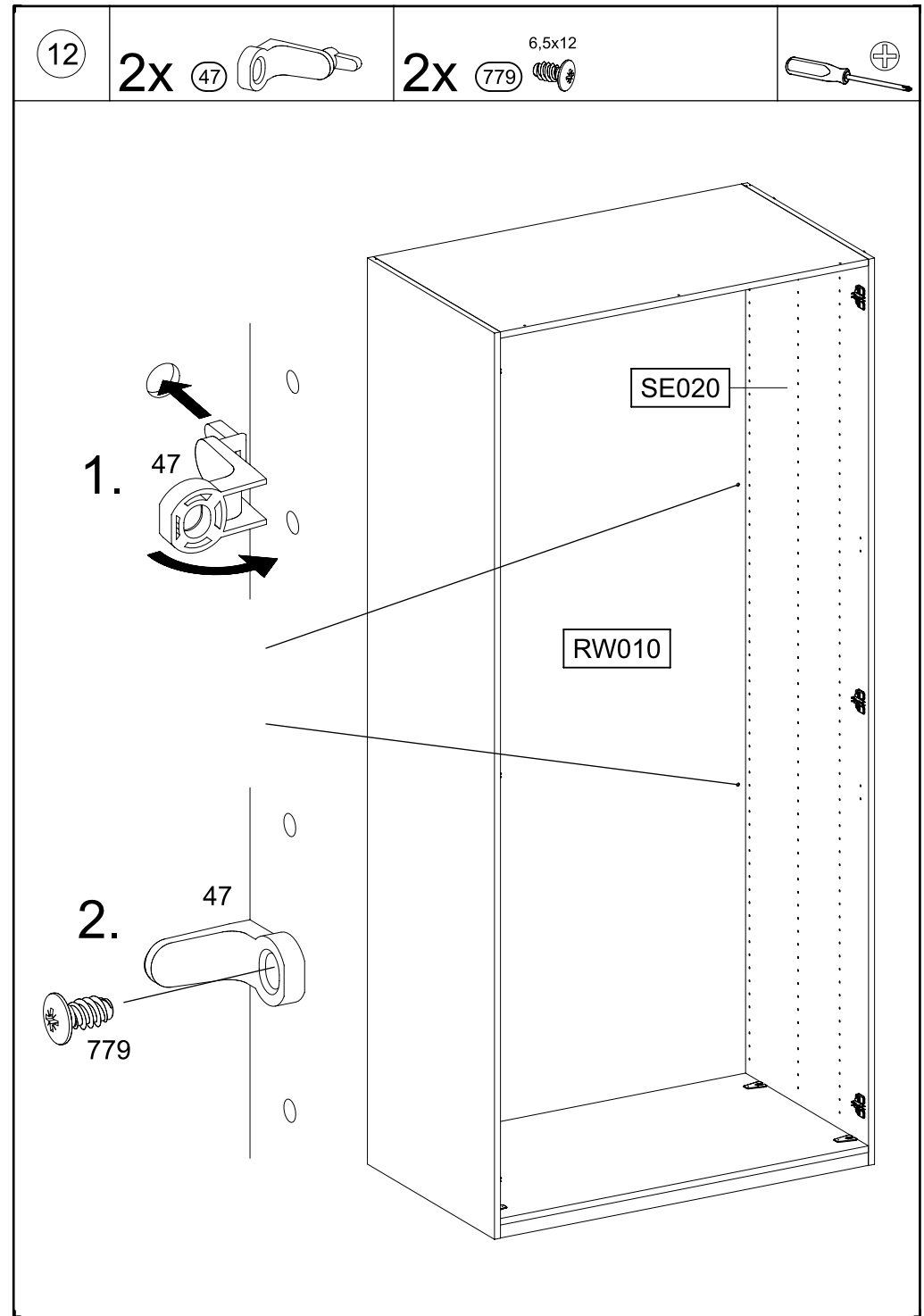
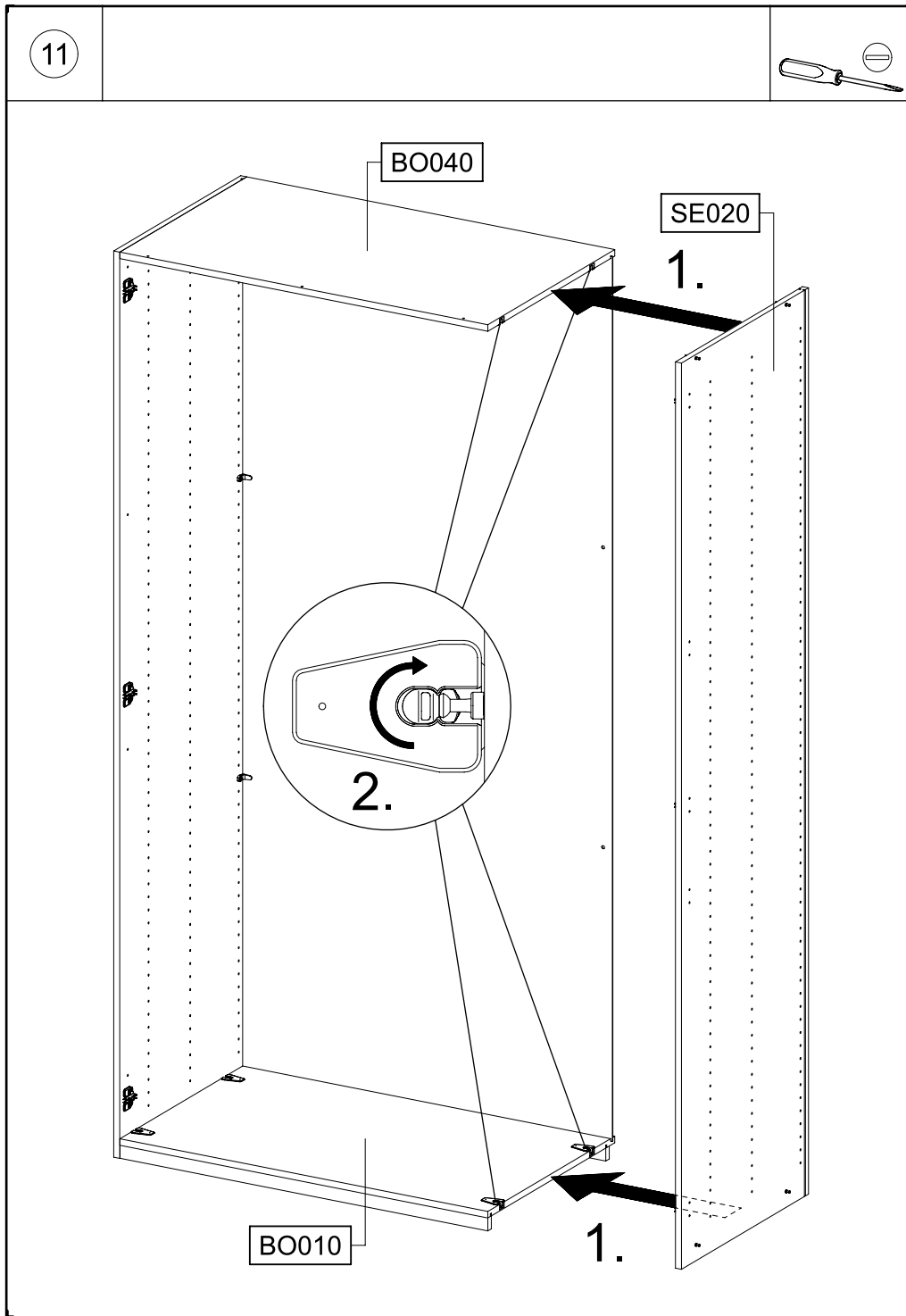

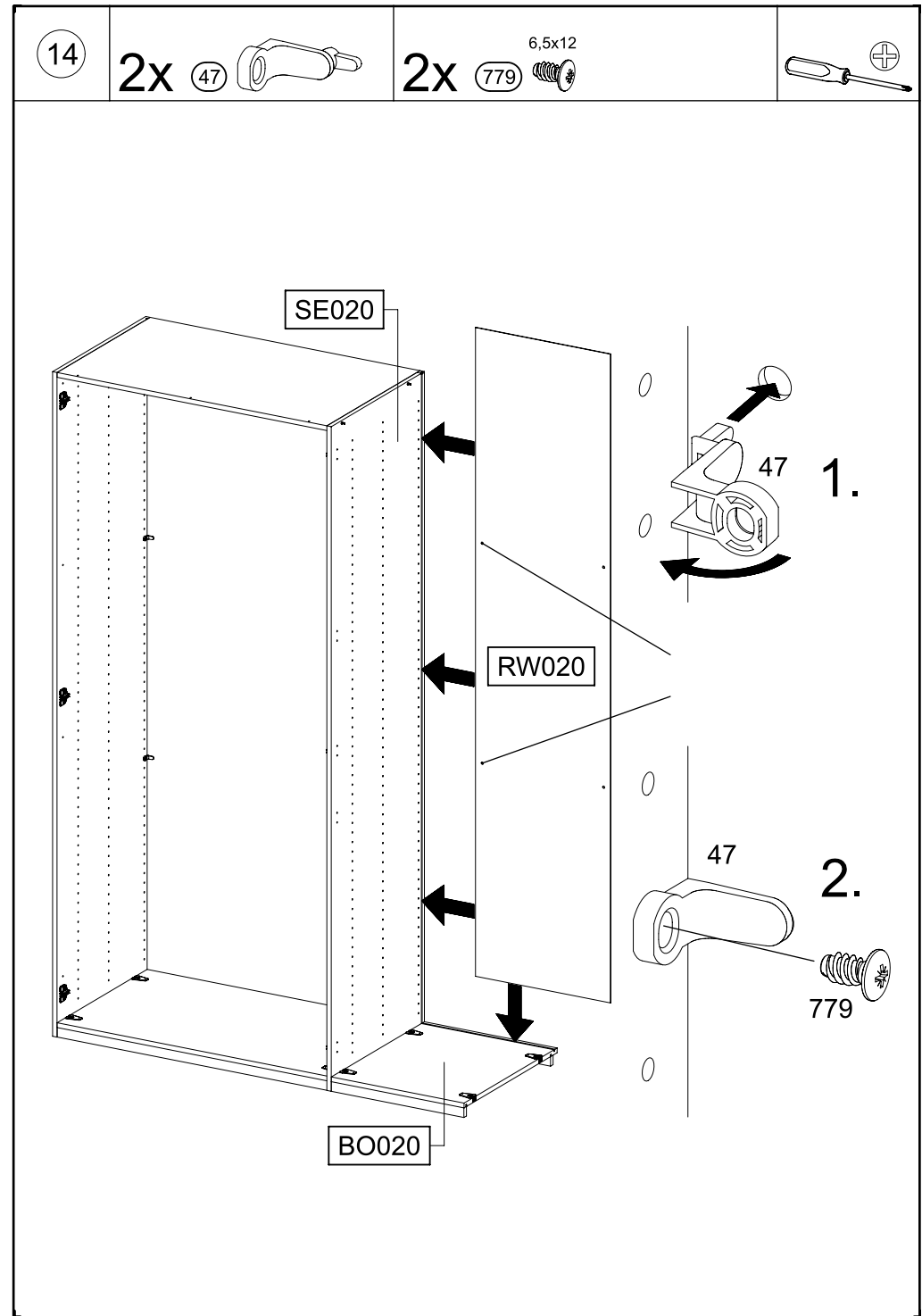
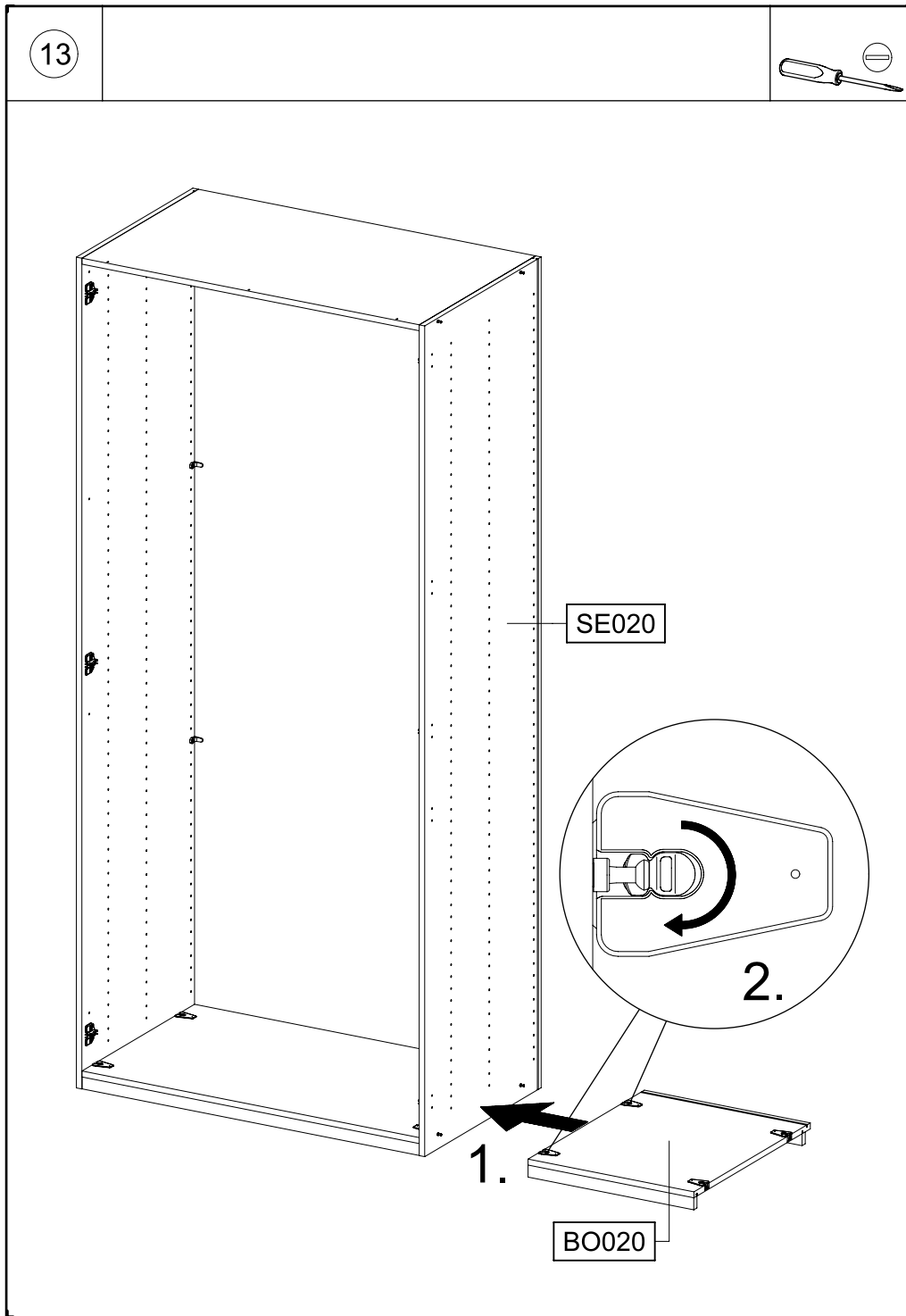

15

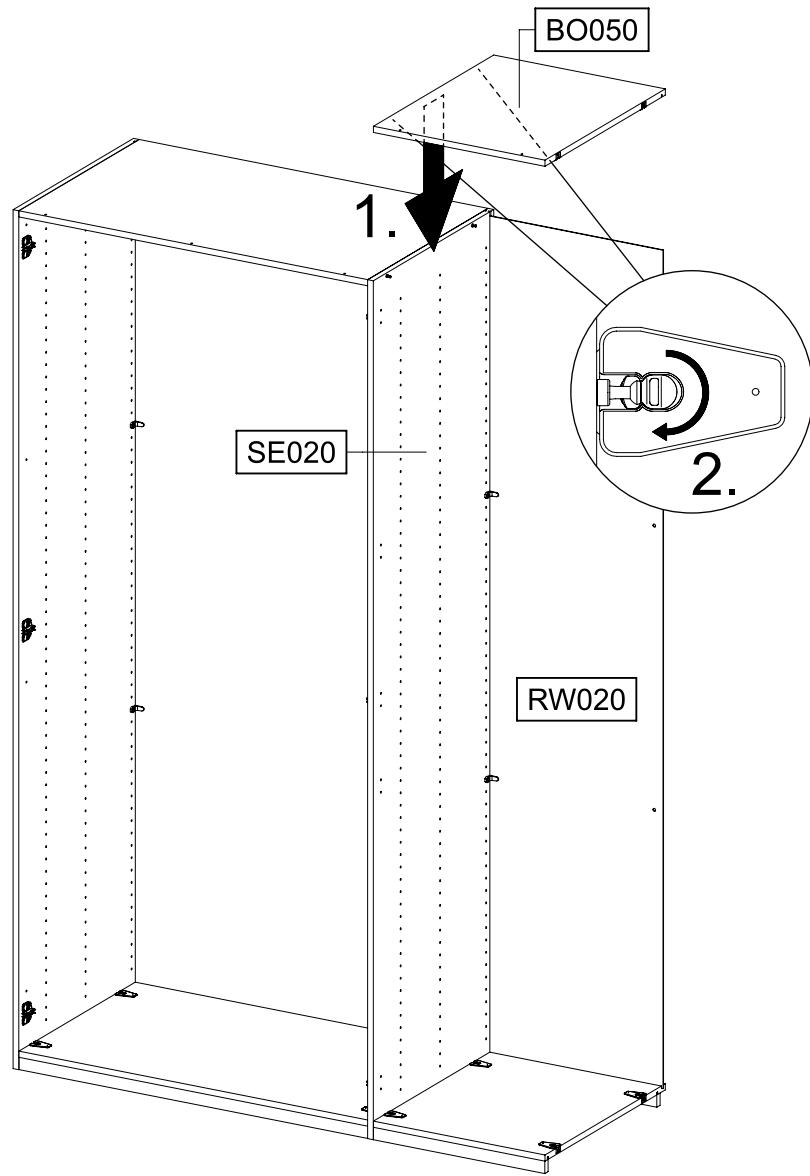
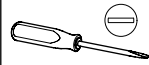

16

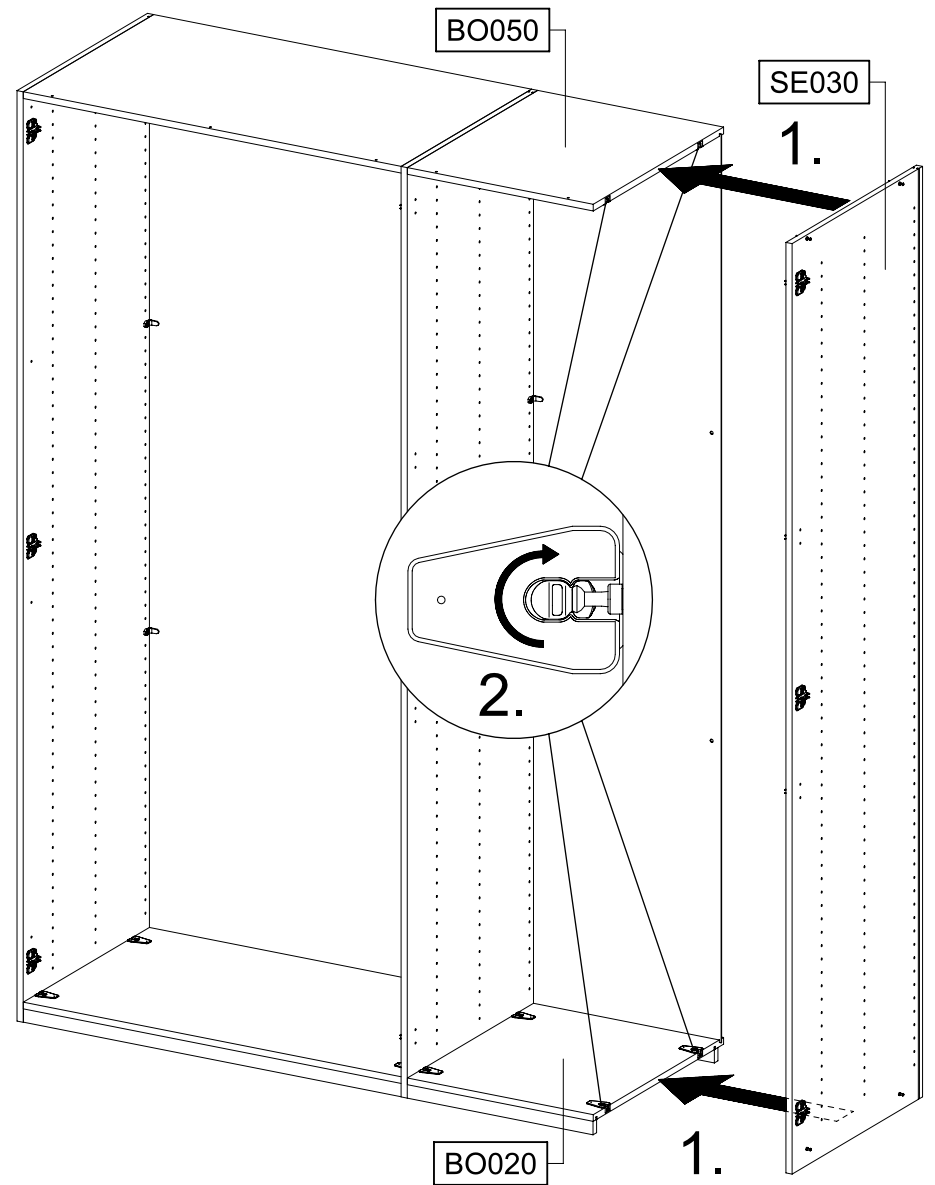
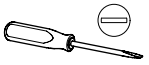

17

2x 47 

2x 779  6,5x12

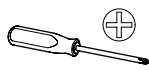

SE030

RW020

1.

47

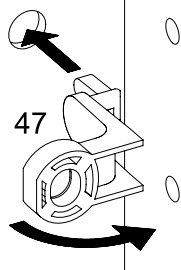

2.

47

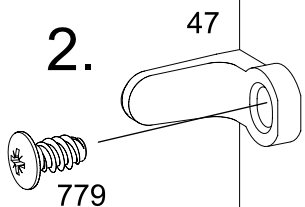

779

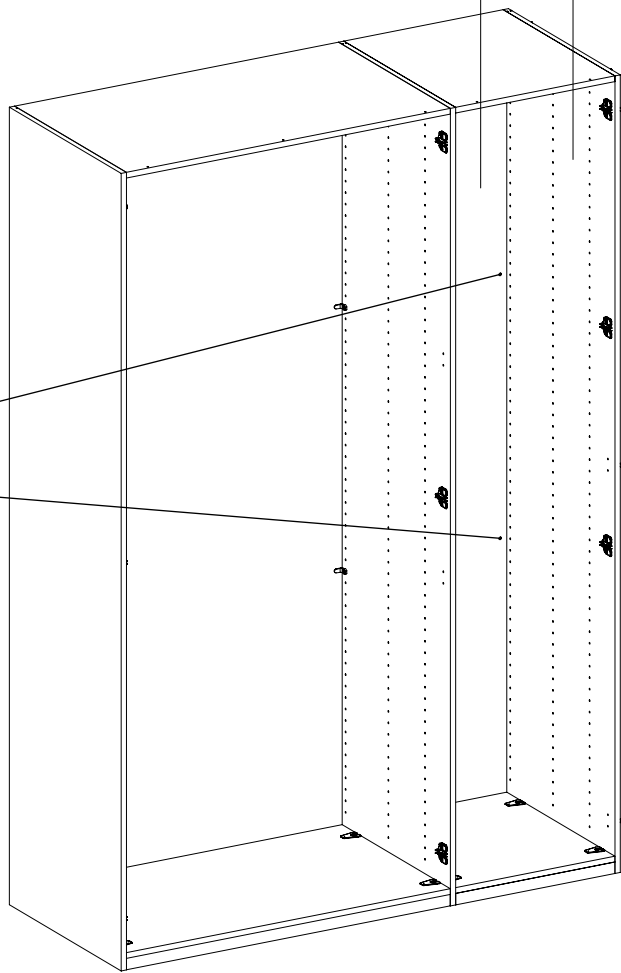

18

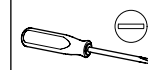

SE030

2.

1.

BO010

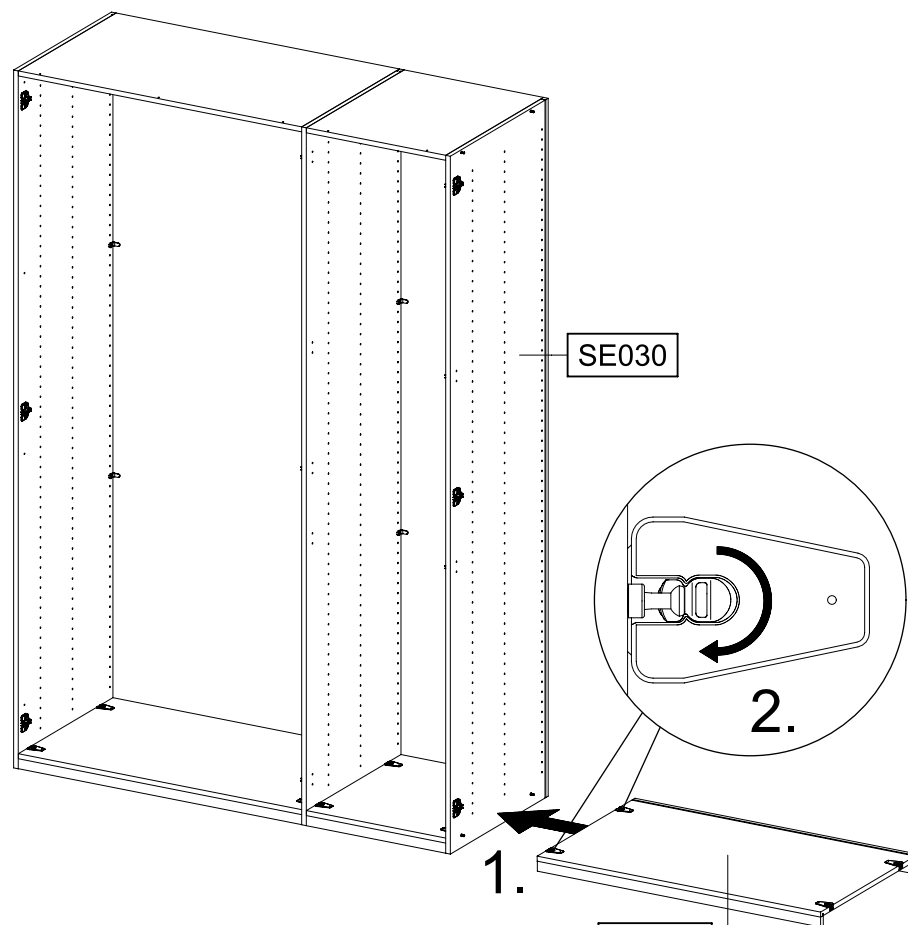

19

2x

47



2x

779

6,5x12

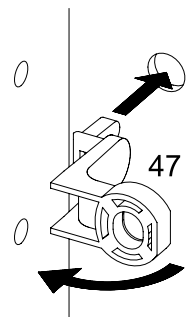
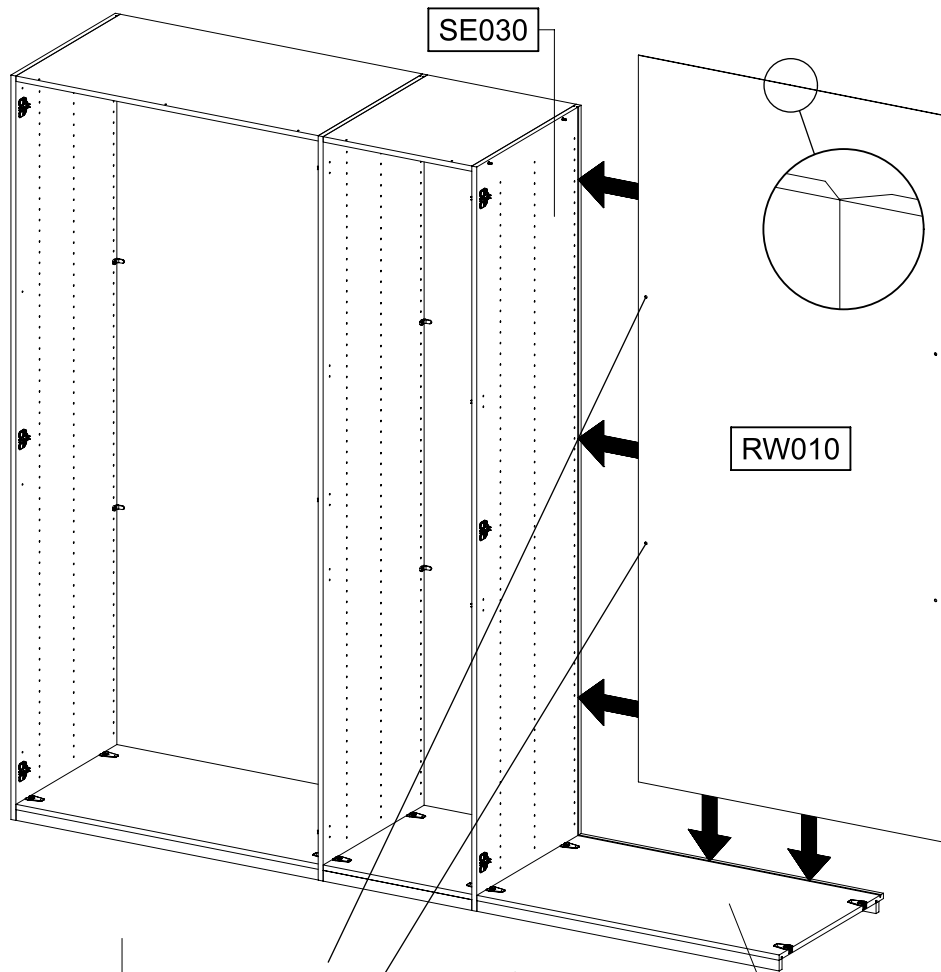
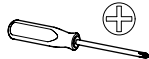

1.

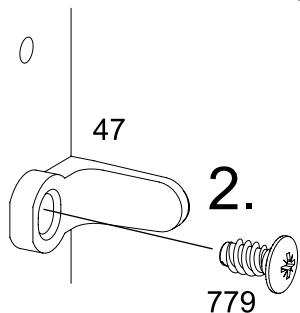

2.

779

20

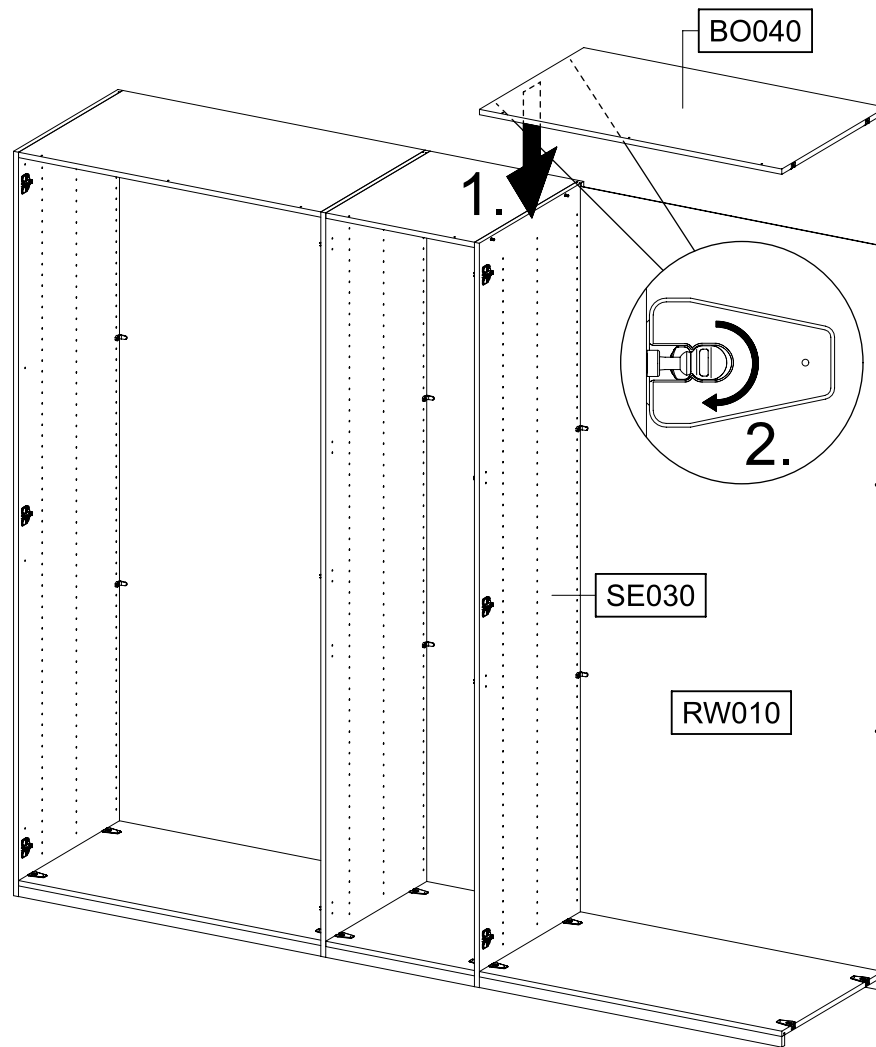
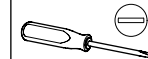

1.

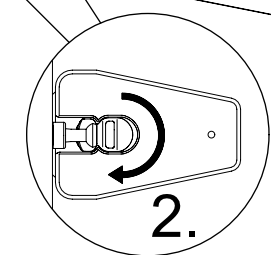

2.

21

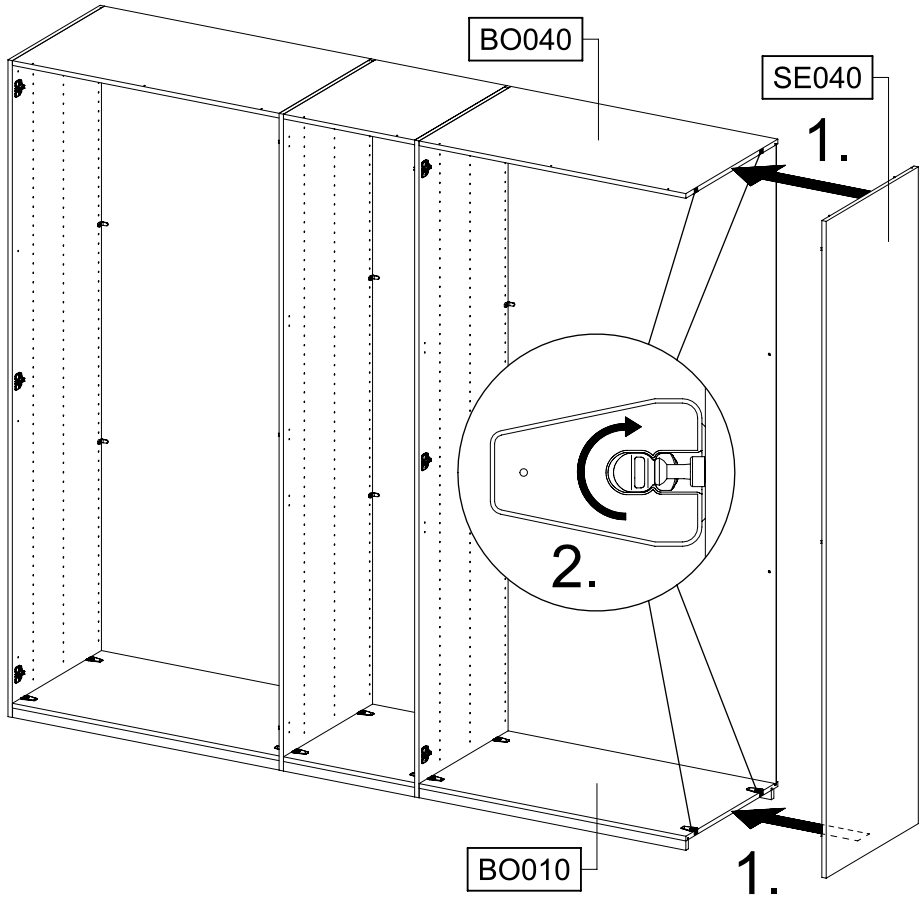
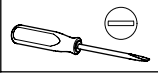

22

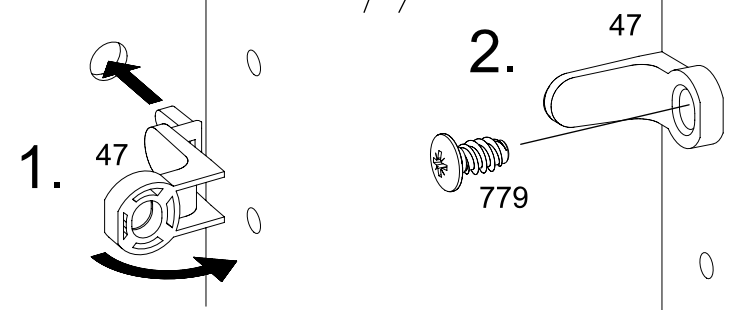
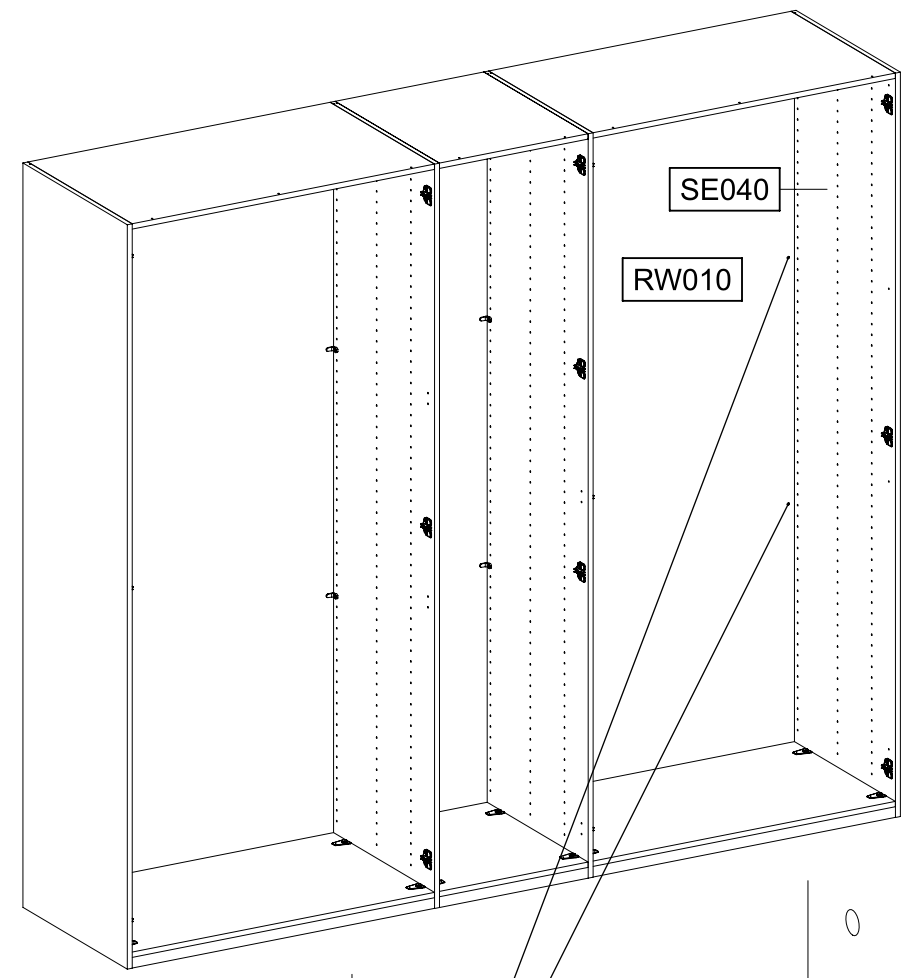
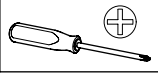
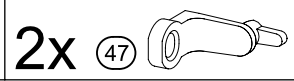

23

4x 1089

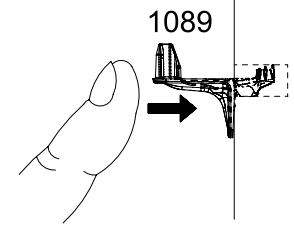
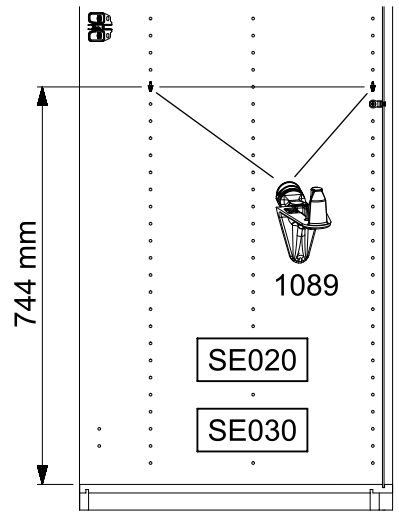
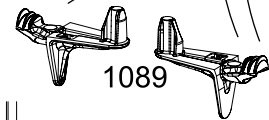
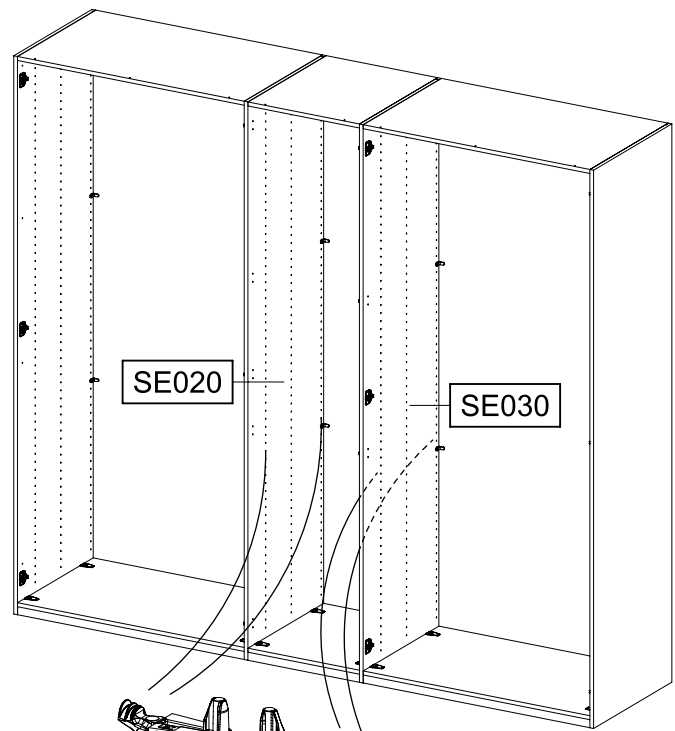
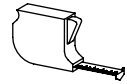

24

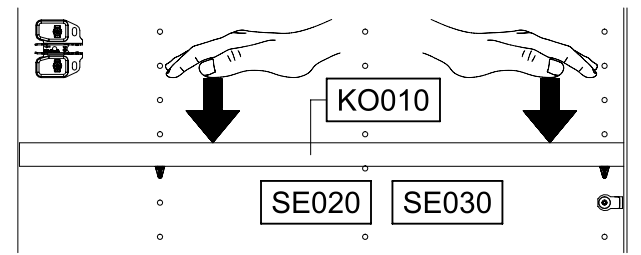
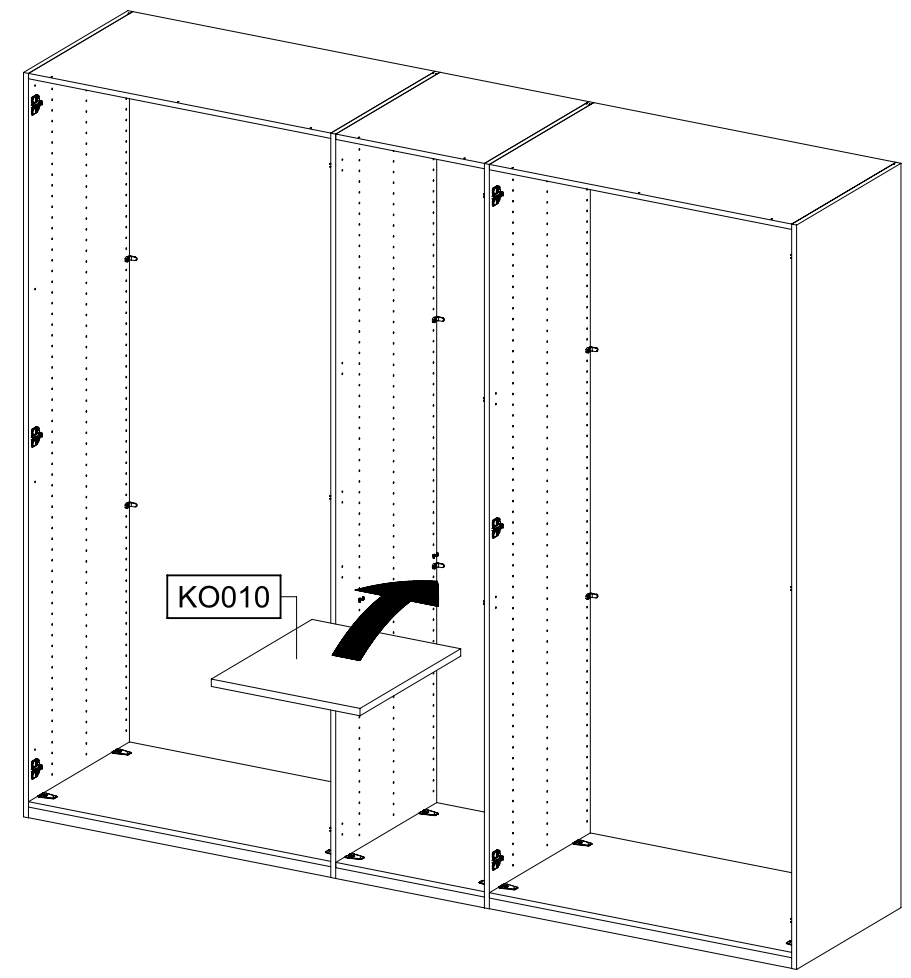

25

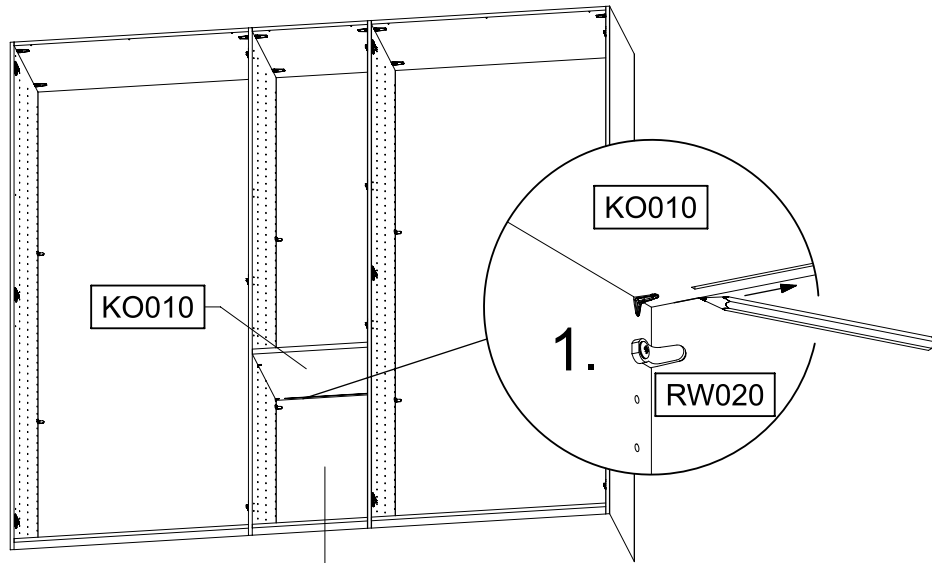

RW020

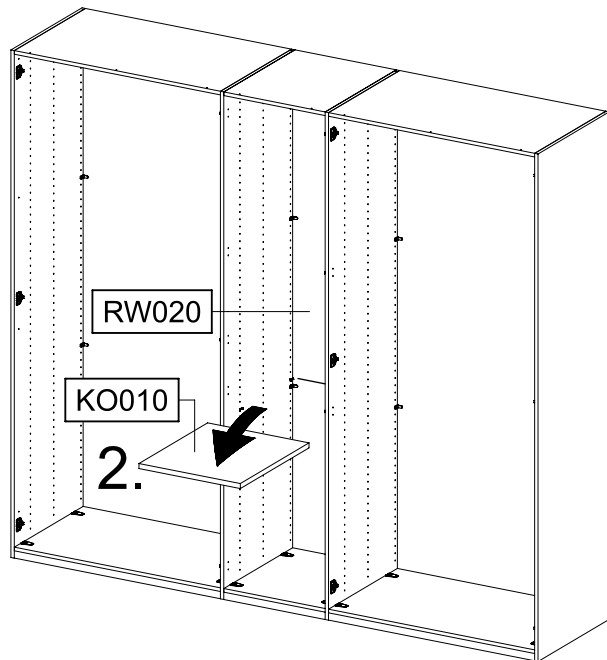

26

1x 201 4x15

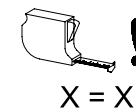
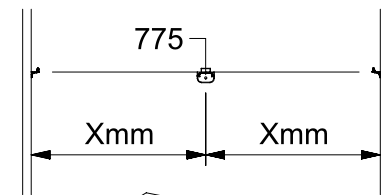
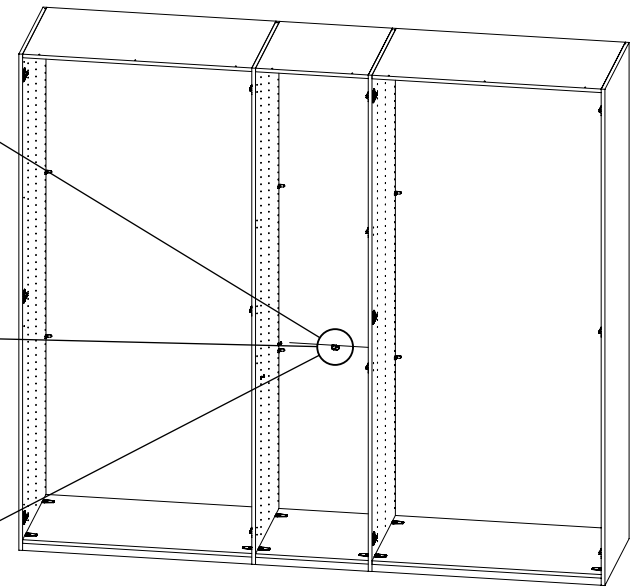
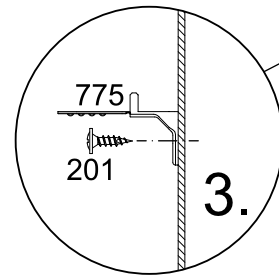
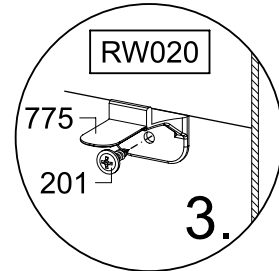
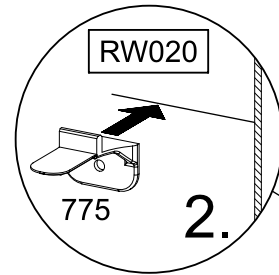
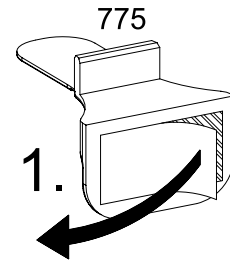
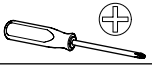
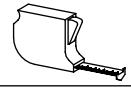
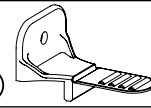

1x 775

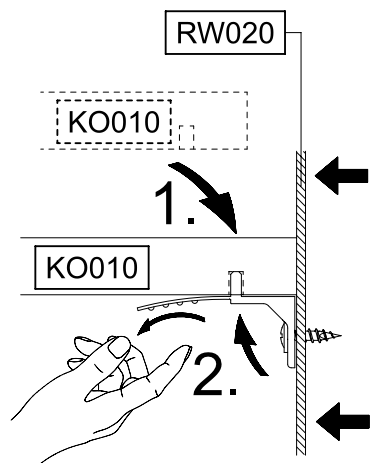
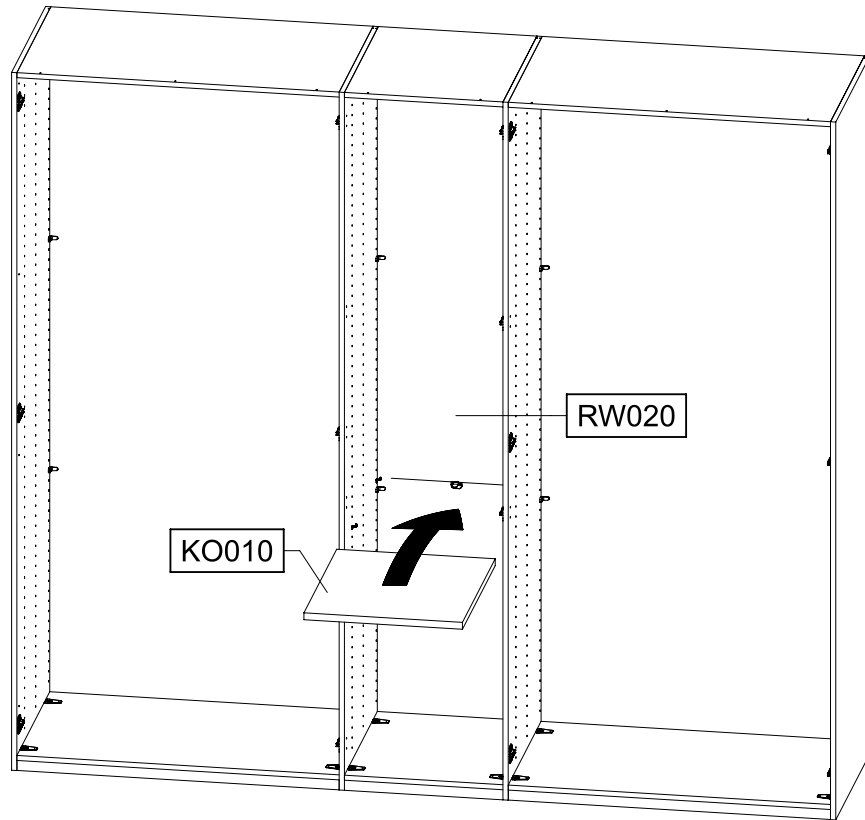

27

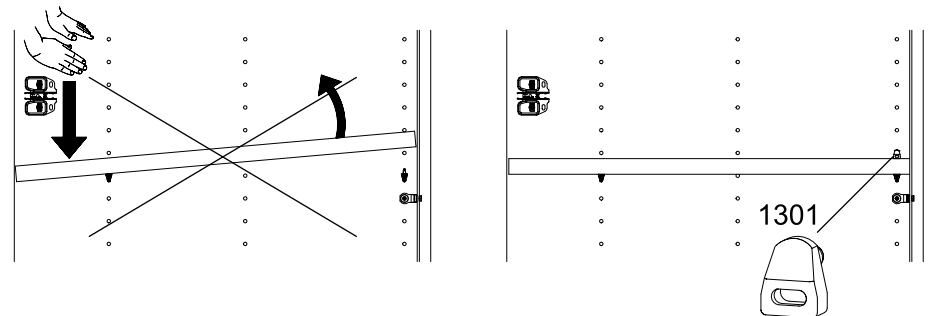
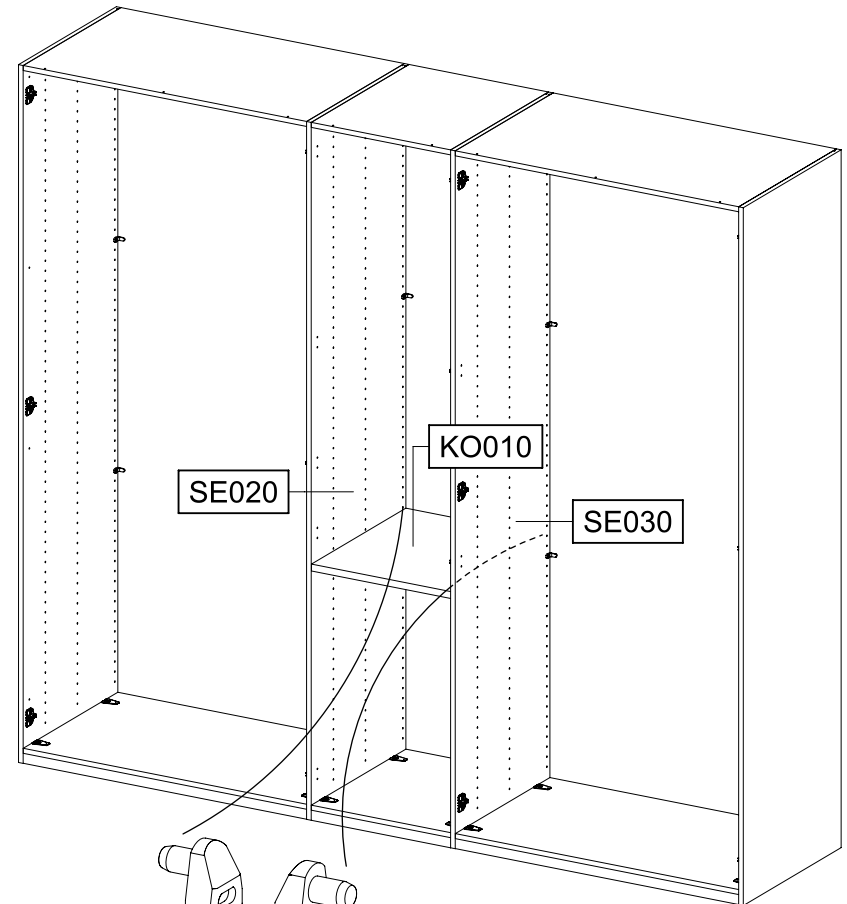

28

2x 1301 

29

20x 1089

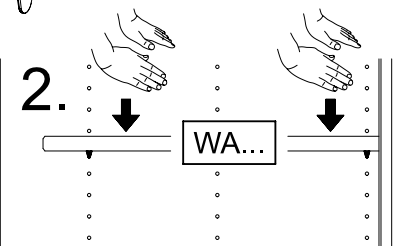
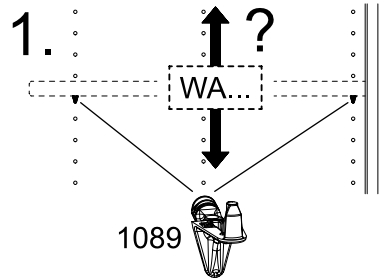
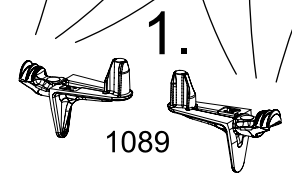
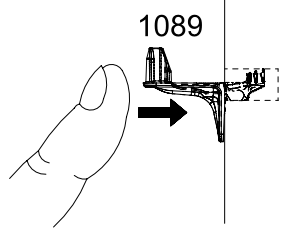
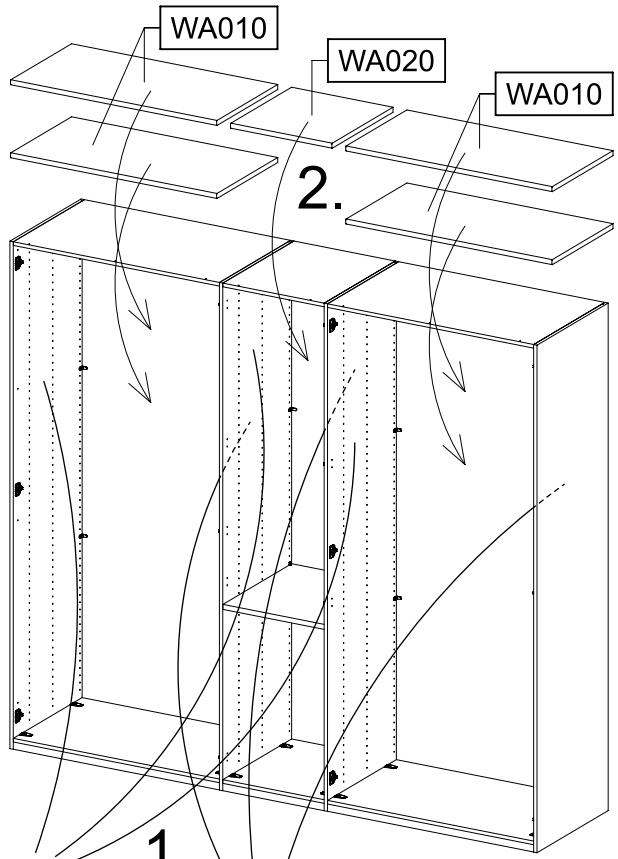

30

6x 29



6x 205

3,5x15

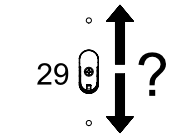
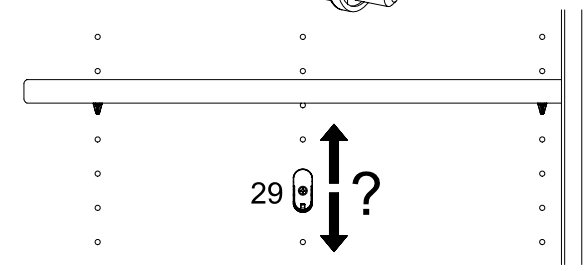
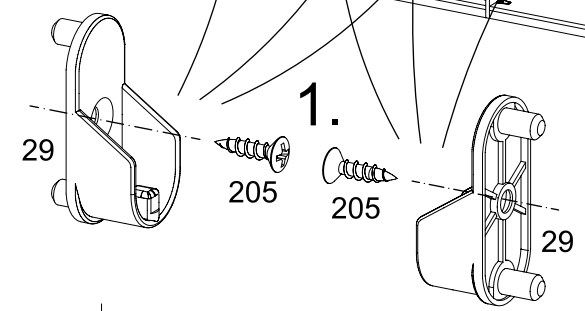
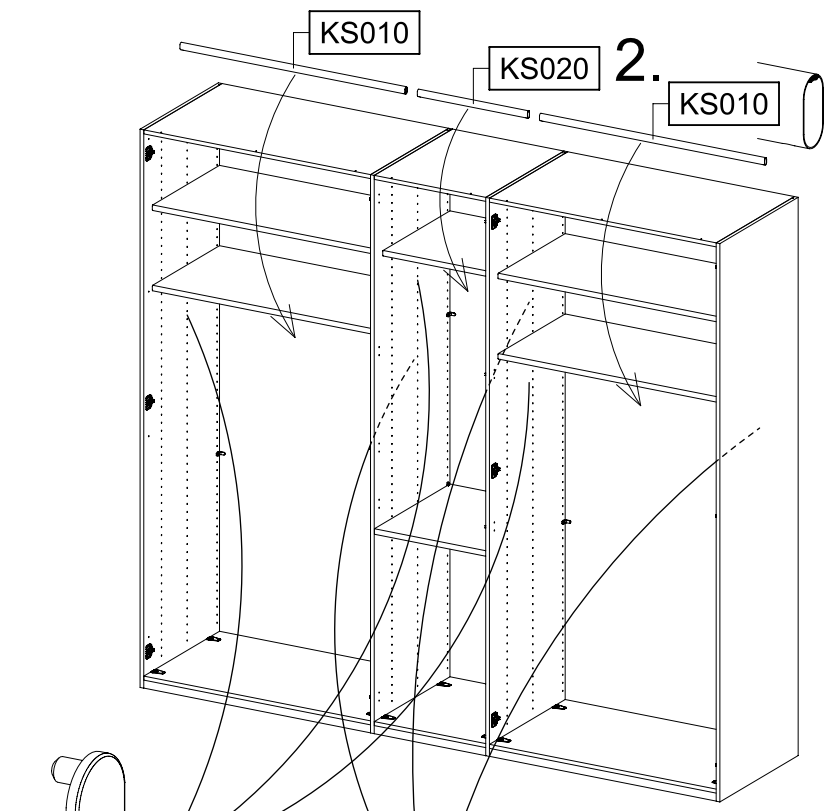
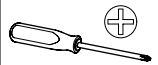

31

12x 792 6,3x9

12x 836 4x15

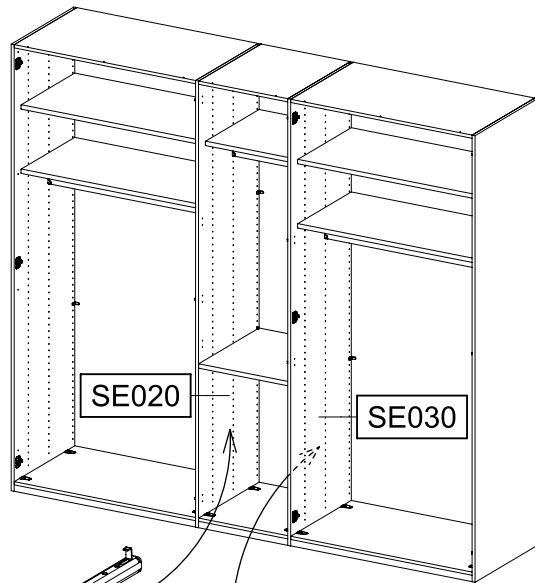
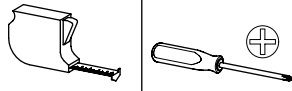

3x UF010

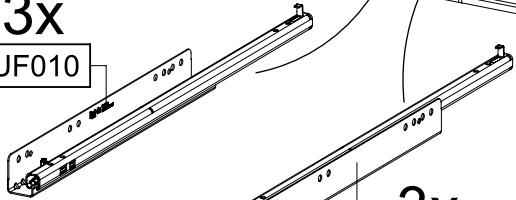

3x UF020

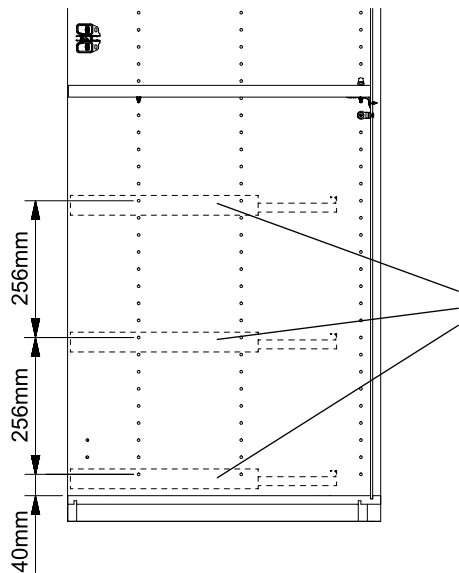
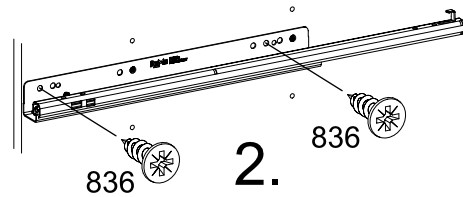
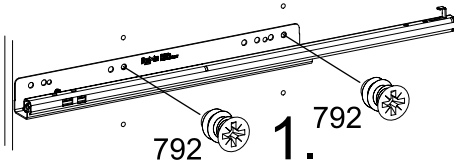

32

6x 852

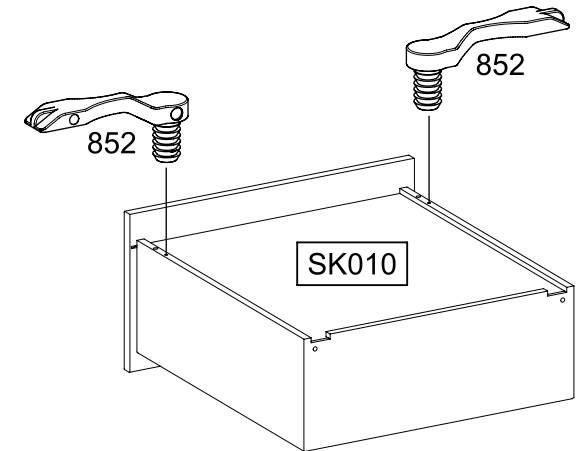
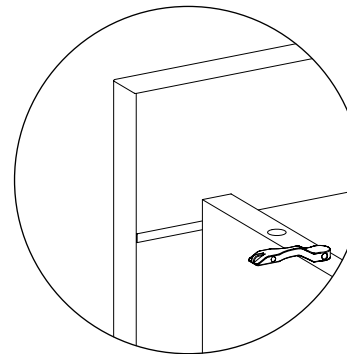
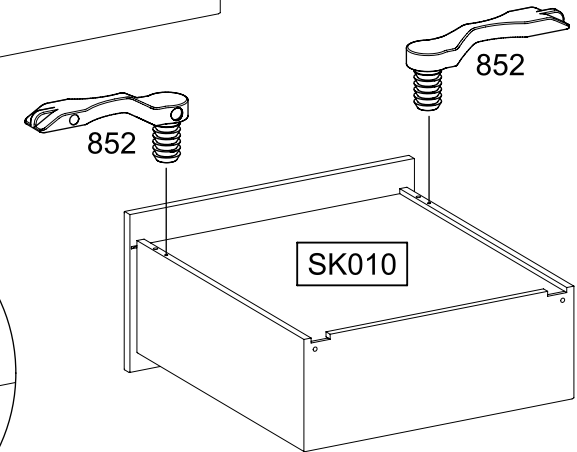
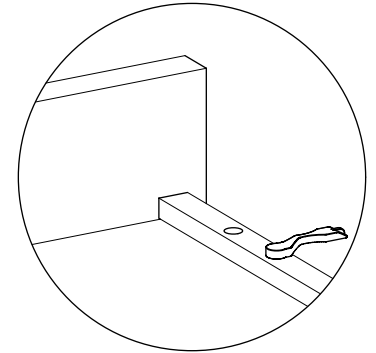
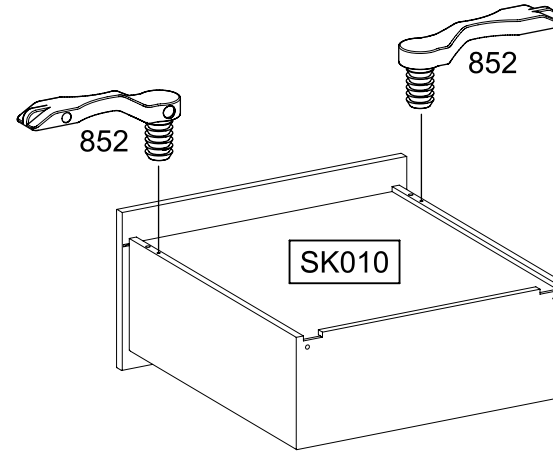
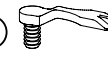

33

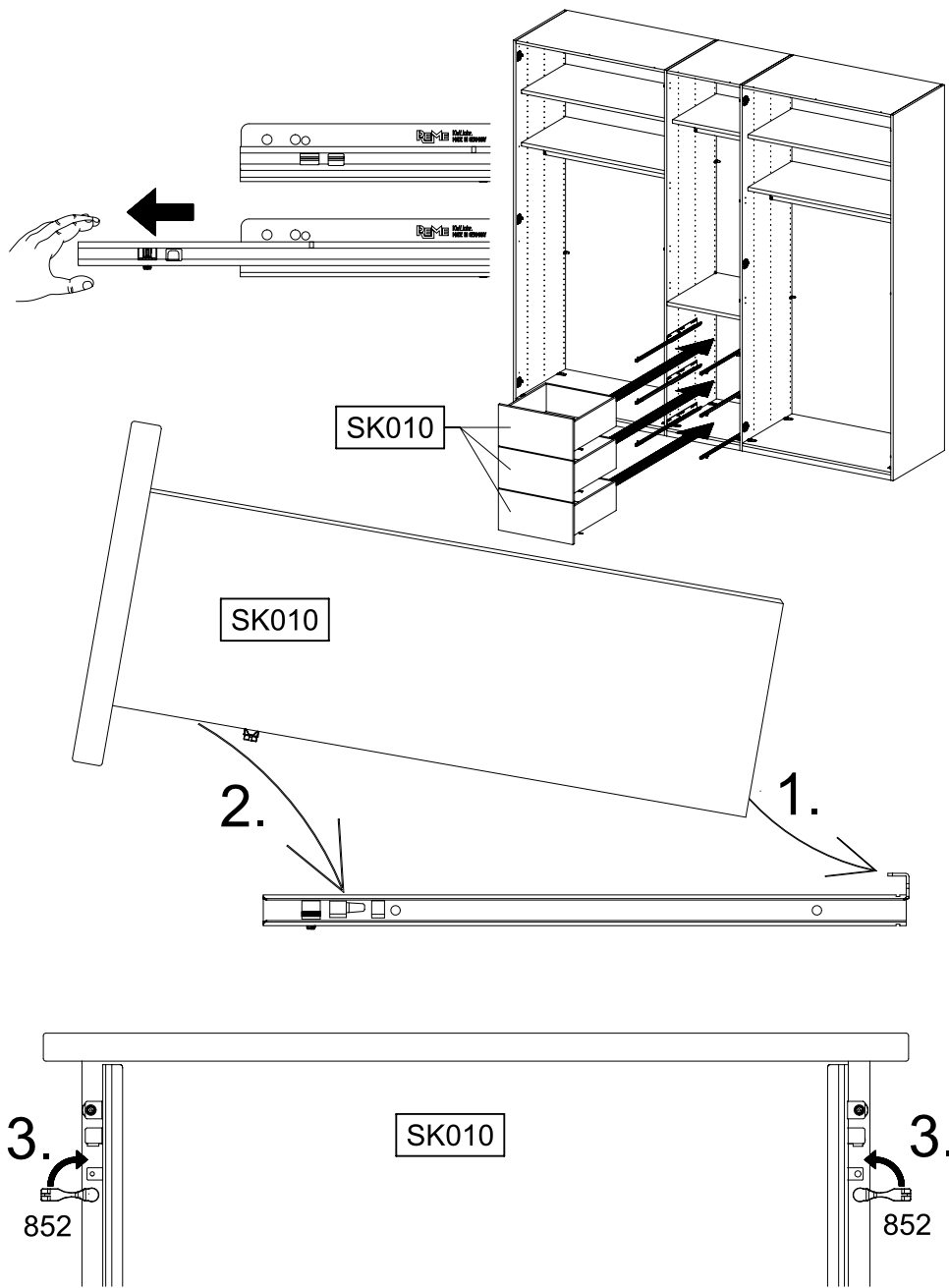

34

15-19x 1292

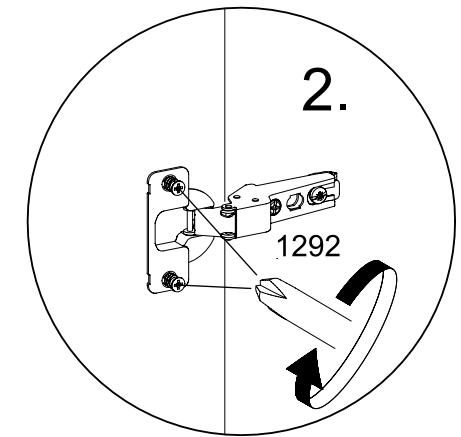
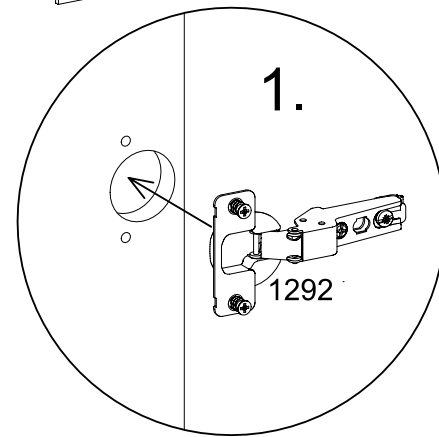
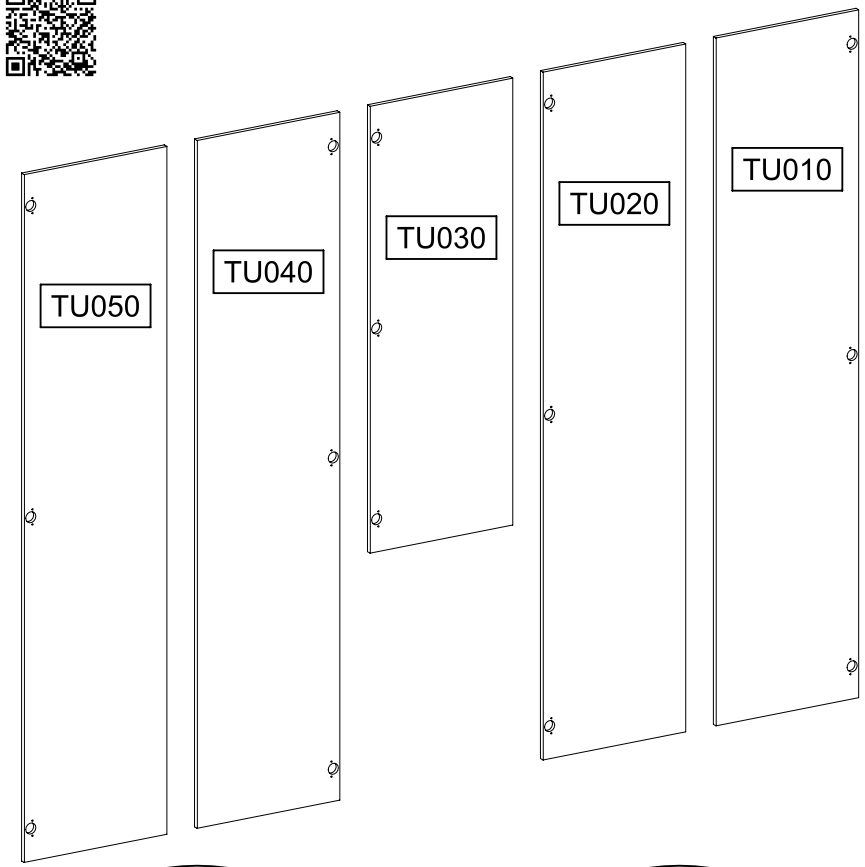
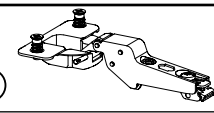

35

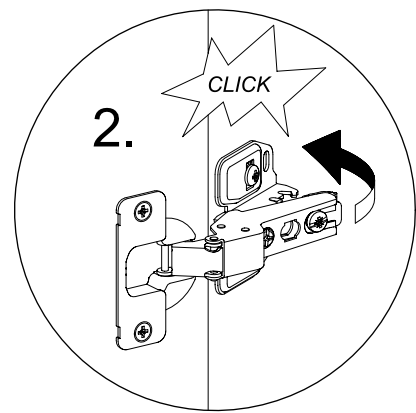
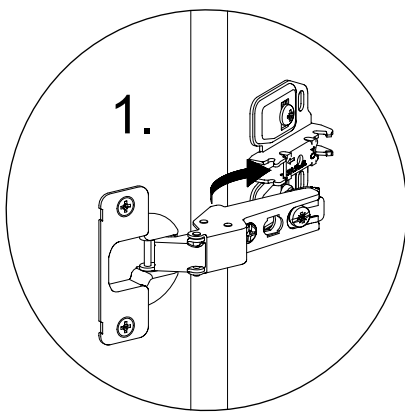
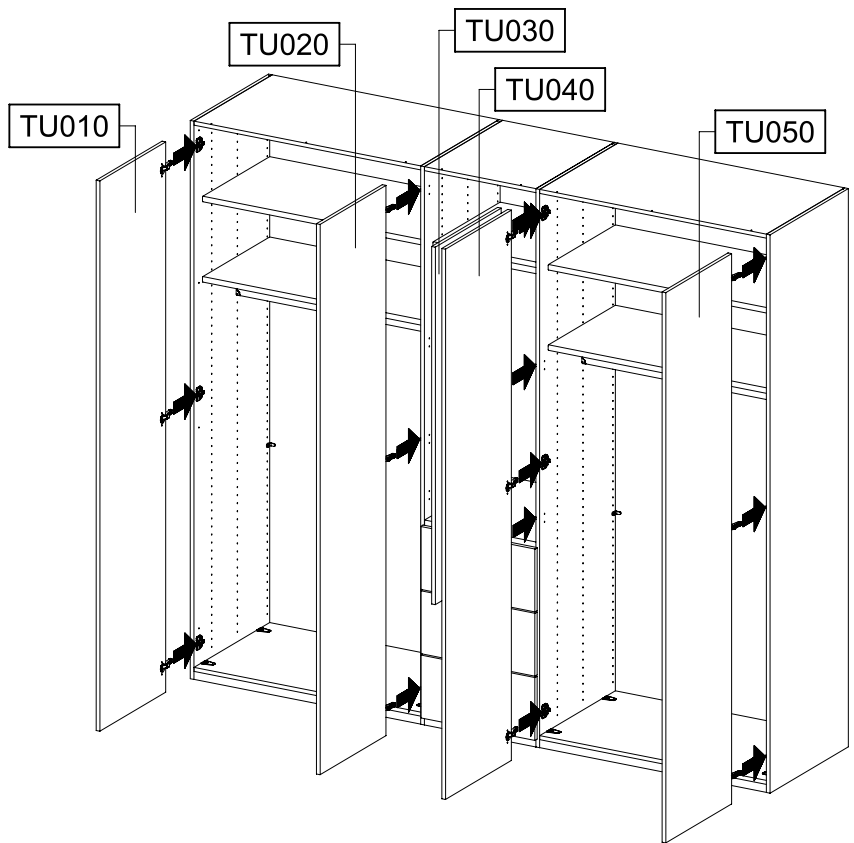

36

0-9x 12 55x16x6,2

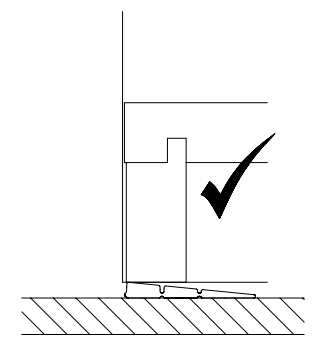
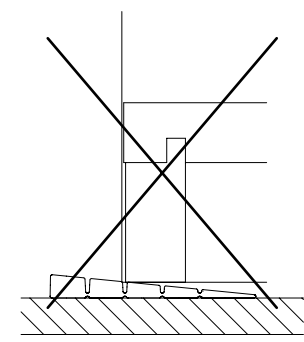
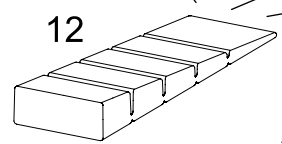
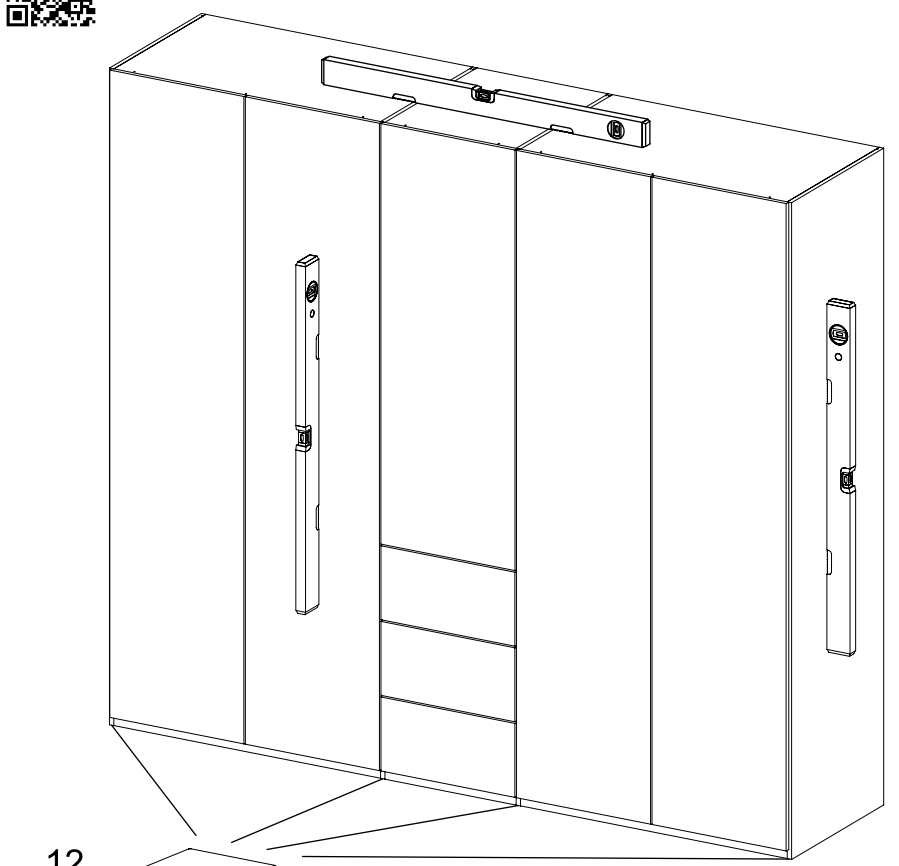
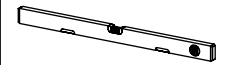

37

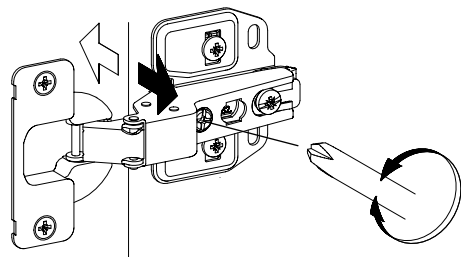
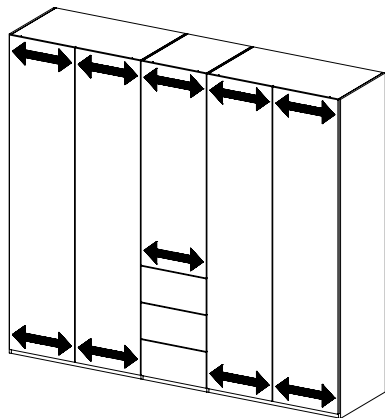
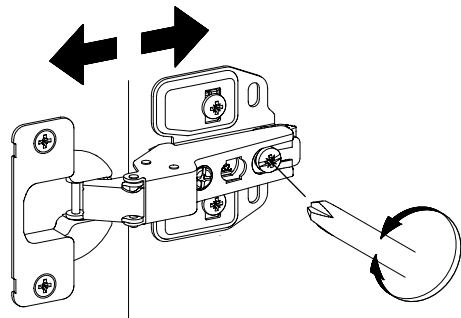
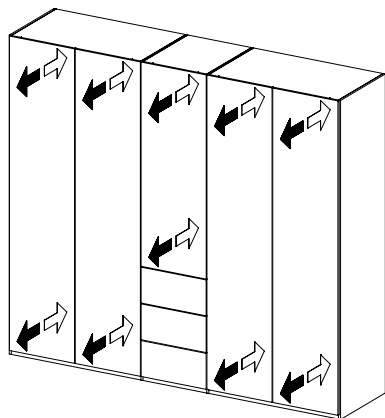
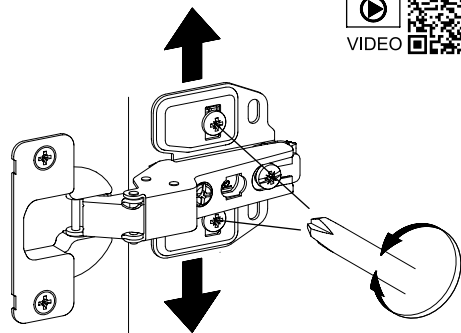
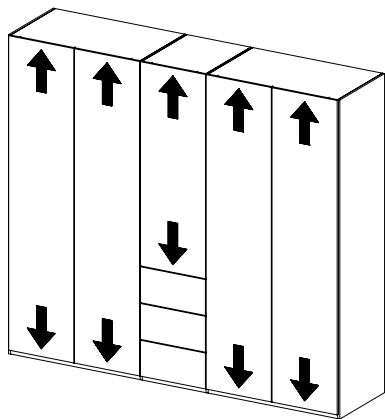
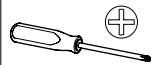

38



SK010

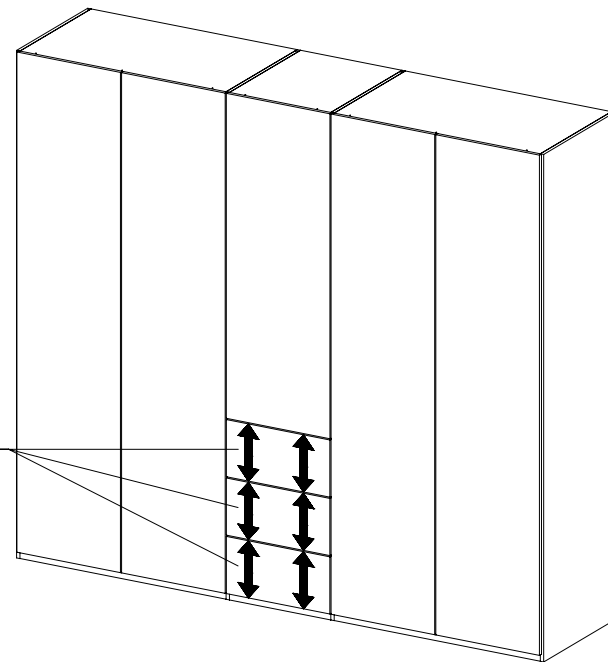

SK010

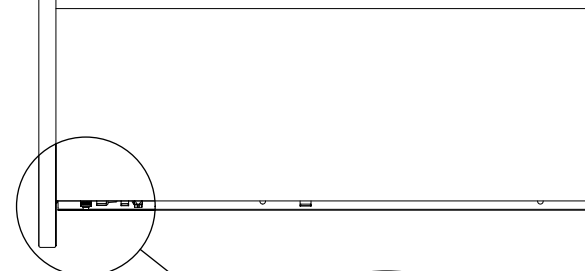

SK010

2.

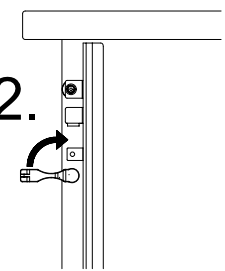

1.

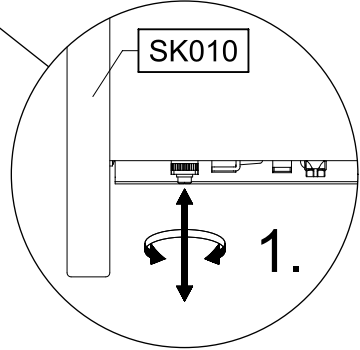

2.

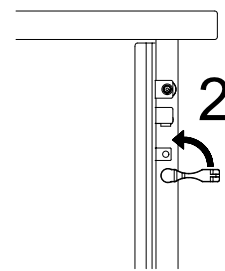

39

30-38x

621

4x13

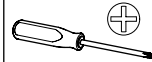

1291

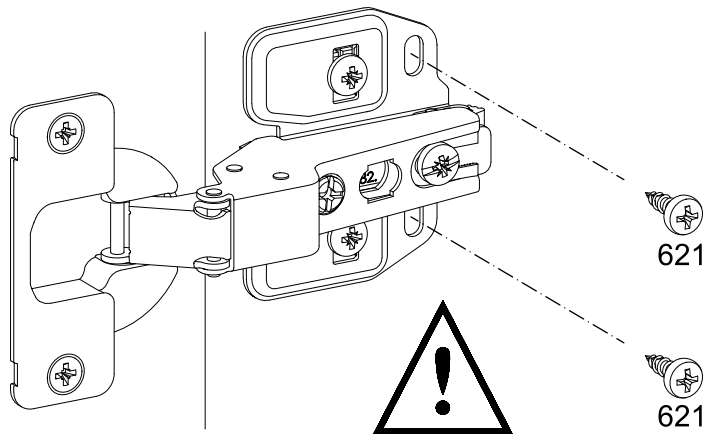

40

2x 68

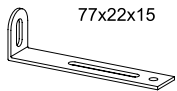

77x22x15

4x 201

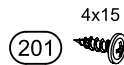

4x15

