

# Musterring



Q-MEDIA

## Aufbauanweisung

(Bitte aufbewahren) (Stand 28.01.2019)



Musterring

# Nutzen Sie die Sicherheit einer großen Marke.



## 5 Jahre Garantie.

Auf Musterring Möbel ist Verlass.

Die Garantiebestimmungen, Gebrauchs- und Pflegeanweisungen sind im Musterring Möbel-Gütepass geregelt.



## Service-Information

Sie erreichen uns per E-Mail oder über das Servicetelefon zu den üblichen Geschäftszeiten.



## Individualität

Die Musterring Produktkennzeichnung belegt, dass Sie ein Unikat gekauft haben.



## Pflege

Wir empfehlen Musterring Pflegeprodukte.

## Lederpflege & Reinigung

Stoff-/ Mikrofaserpflege & Reinigung

Holzpflege und Sonderprodukte



Zu bestellen unter [www.musterring-care.com](http://www.musterring-care.com)  
oder unter der kostenlosen Beratungsnummer  
+ 49 (0) 800 / 88 88 885.

Bei Fragen sprechen Sie uns bitte an;  
wir helfen Ihnen gerne weiter.

**Zur Werterhaltung Ihrer Möbel**



Übersicht der Kombinationen

Seite 1 bis Seite 4

Übersicht der Anbauelemente

Seite 5 bis Seite 31

Übersicht der Rückwandelemente

Seite 32 bis Seite 37

Übersicht der Hängeelemente

Seite 38 bis Seite 64

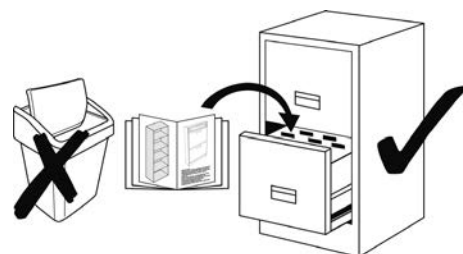
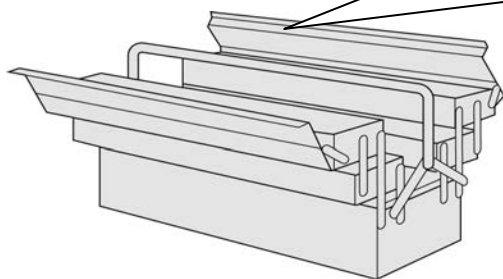
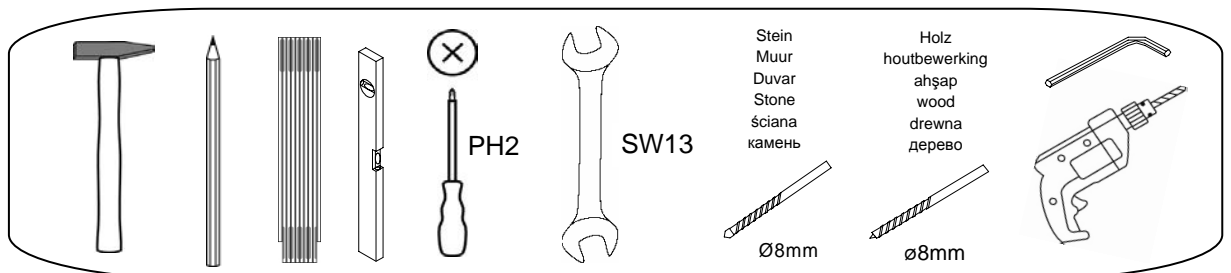
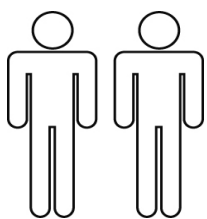

# Q-Media

## Vorschlagskombi Übersicht



VORSCHLAG 2

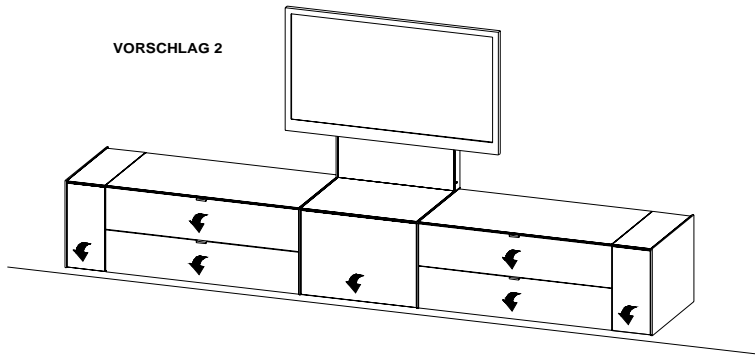

VORSCHLAG 4

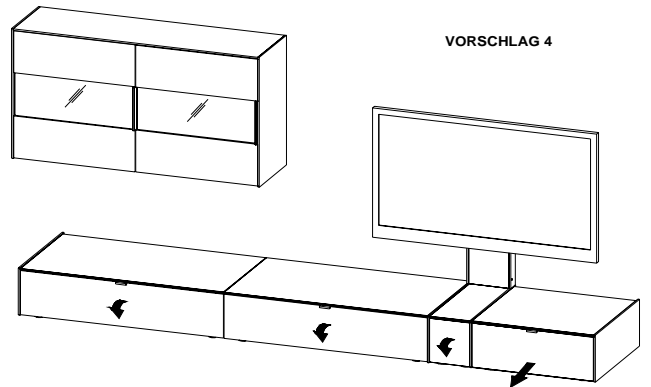

VORSCHLAG 1

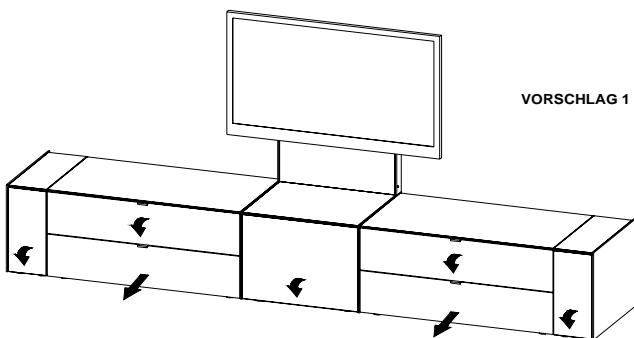

VORSCHLAG 3

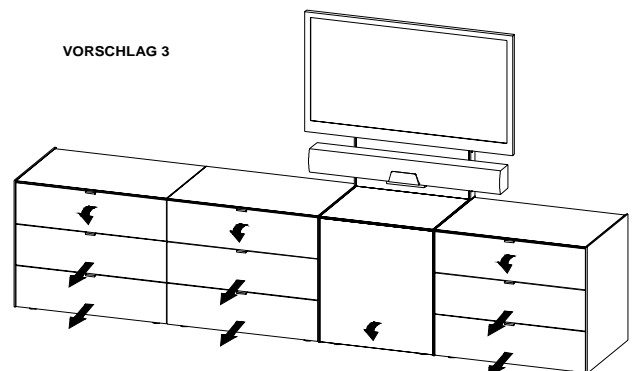

VORSCHLAG 6

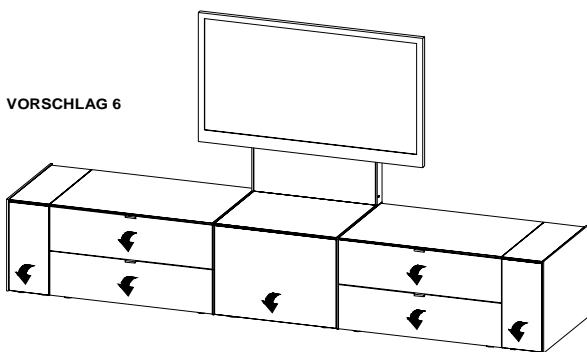

VORSCHLAG 17

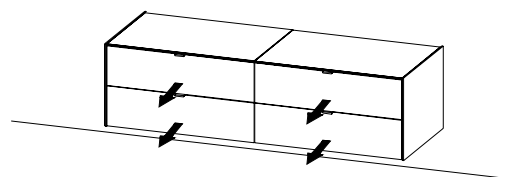

VORSCHLAG 5

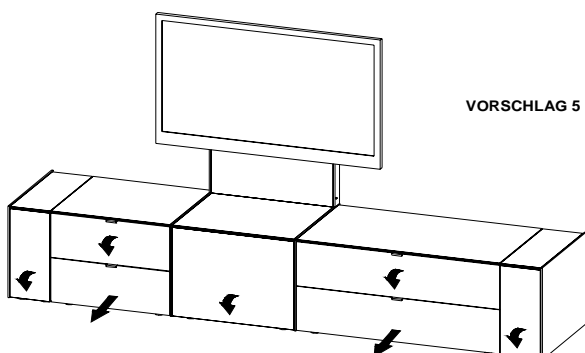

VORSCHLAG 7

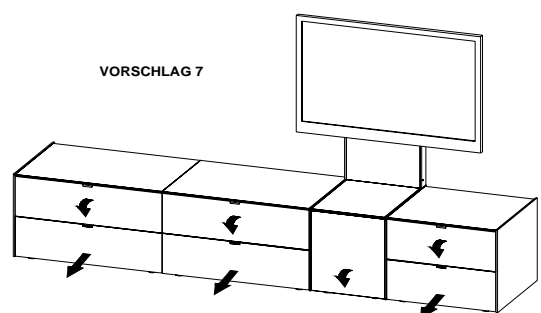



# Q-Media

## Vorschlagskombi Übersicht

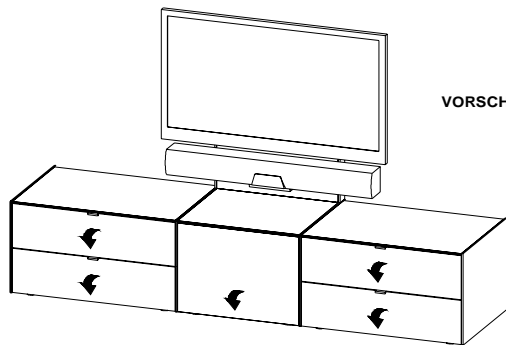

VORSCHLAG 21

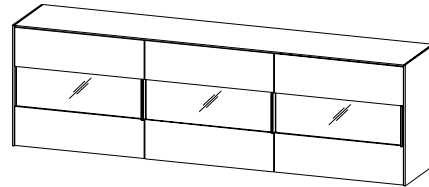

VORSCHLAG 26

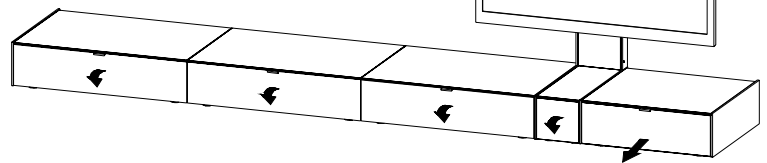

VORSCHLAG 22

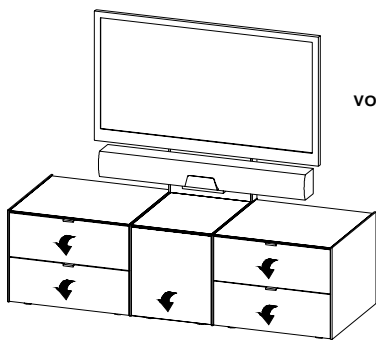

VORSCHLAG 20

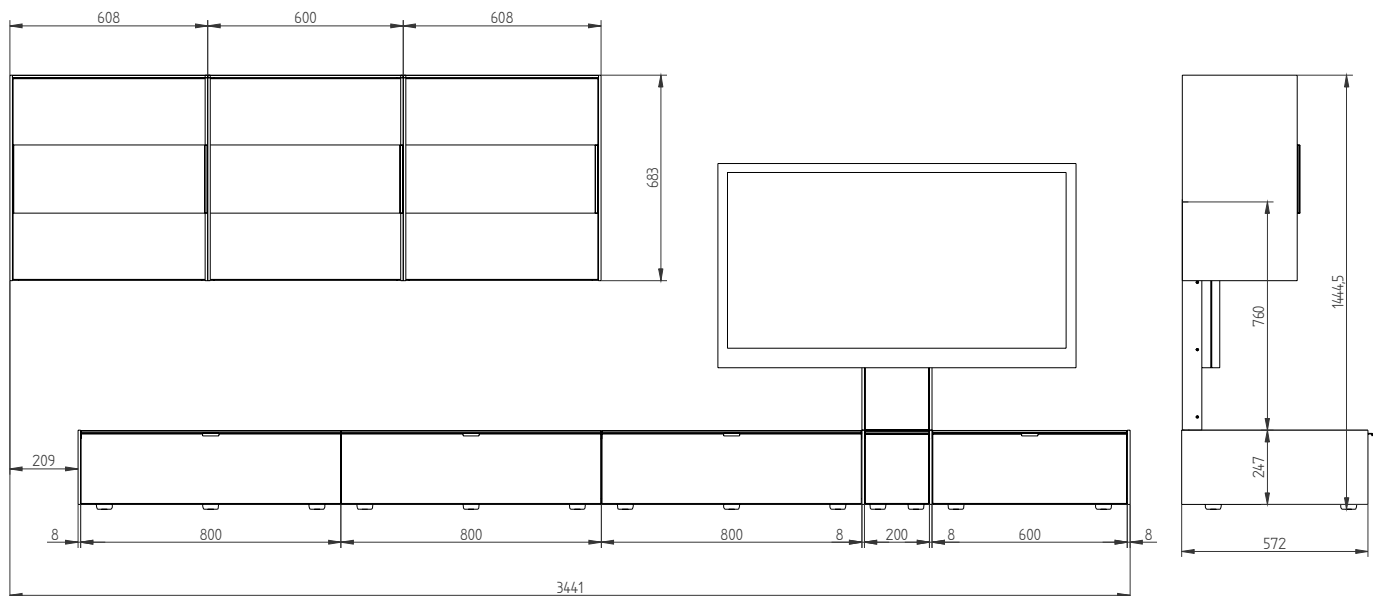
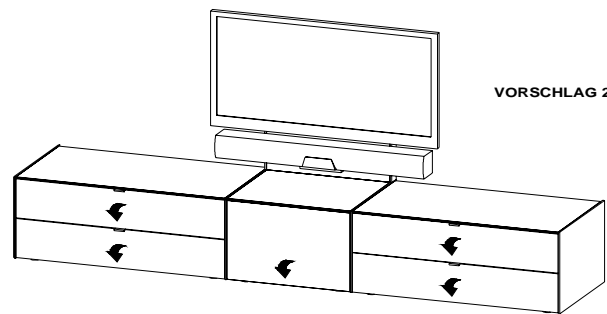

Änderung/ Oz. nach: zm.	Abmessungen / Wymiary:		Datum / Data		Name / Nazwa		Universalfabrik		
	3441 x 1444 x 572 mm								
Konstr.	K.Flagmeier		04.09.2013	Bezeichnung / Nazwa części:				Menge/ Ilość sztuk:	Maßstab/ Skala:
Zatw.				<b>Vorschlagskombination 726</b>					
Zeichnungsnummer / Nr rysunku CAD:		CNC-Nr. / Nr programu CNC:		Modell / Nazwa modelu:				Werkstoff/Material:	
KOMBI_26.dft				<b>Q-Media</b>					



## Musterring

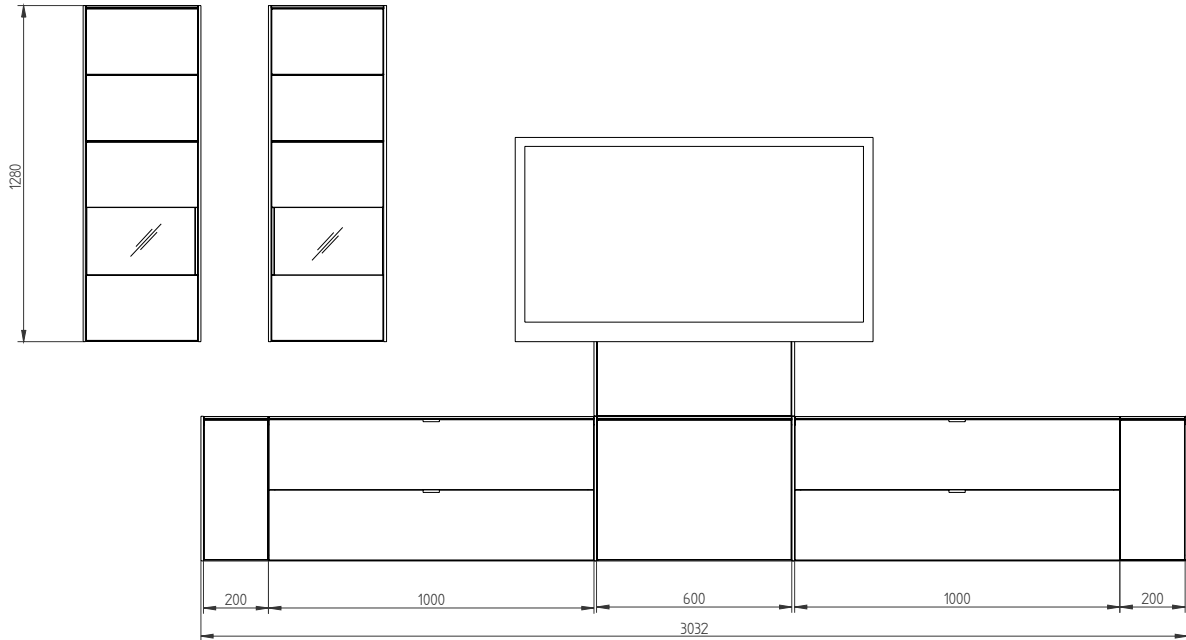

Änderung/ Oznac. zm.	Abmessungen / Wymiary:			Datum / Data	Name / Nazwisko	Umzeichnung/Popis	
	304 x 126 x 57 cm						
Konstr.	K.Flagmeier		05.09.2013	Bezeichnung / Nazwa czesci:		Menge/ Ilosc sztuk:	Maßstab/ Skala:
Zatw.				<b>Vorschlagskombi 701</b>			
Zeichnungsnummer / Nr rysunku CAD:		CNC-Nr. / Nr programu CNC:		Modell / Nazwa modelu:		Werkstoff/Material:	
KOMBI_1.dft				<b>Q-Media</b>			

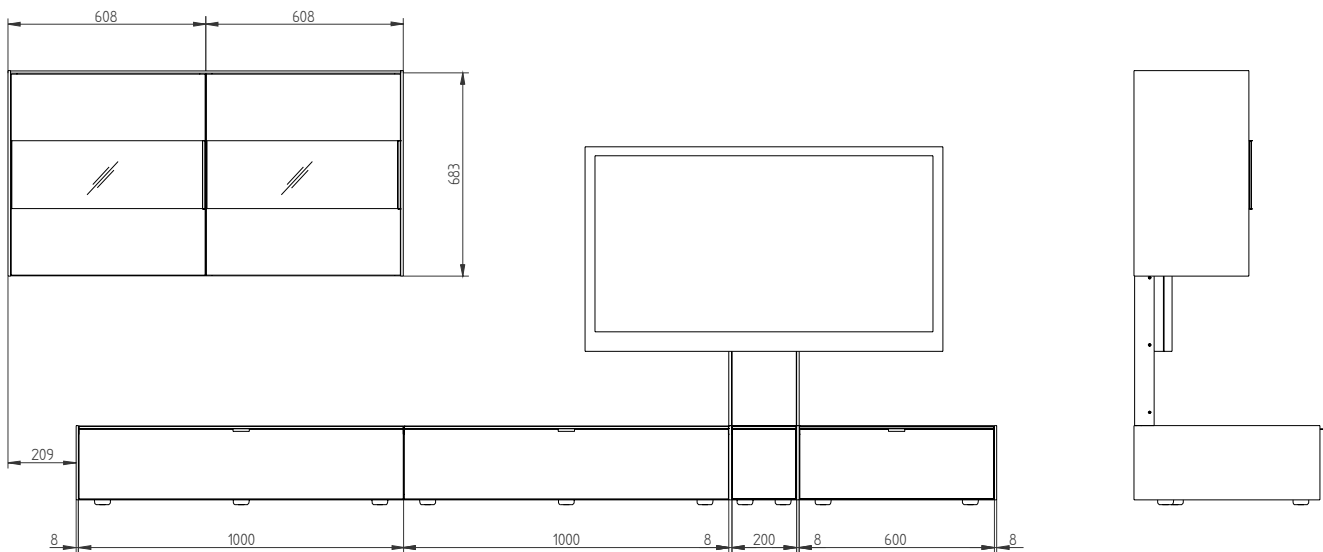

Änderung/ Oznac. zm.	Abmessungen / Wymiary:			Datum / Data	Name / Nazwisko	Umzeichnung/Popis	
	3041 x 1444 x 572 mm						
Konstr.	K.Flagmeier		04.09.2013	Bezeichnung / Nazwa czesci:		Menge/ Ilosc sztuk:	Maßstab/ Skala:
Zatw.				<b>Vorschlagskombination 704</b>			
Zeichnungsnummer / Nr rysunku CAD:		CNC-Nr. / Nr programu CNC:		Modell / Nazwa modelu:		Werkstoff/Material:	
KOMBI_4.dft				<b>Q-Media</b>			

# Q-Media

Anbau-Elemente 1R/2R/3R  
Breite 60cm / 80cm / 100cm

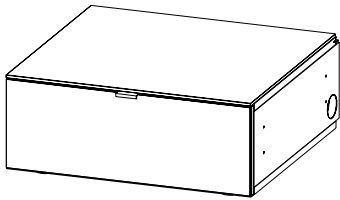

1R

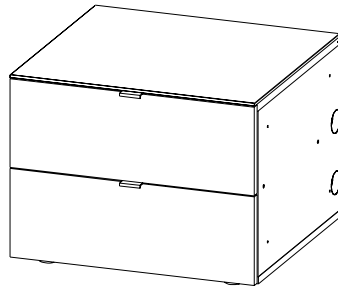

2R

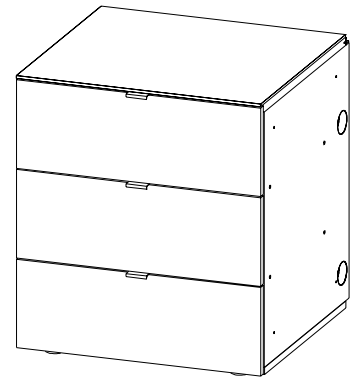

3R

## Beschlagteile Typ 1R/2R/3R

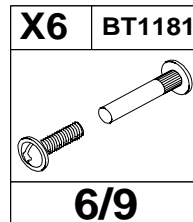
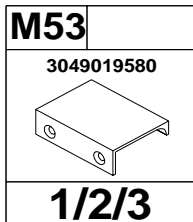

Beschlag / Fitting / Montaža / Felszerelés / Montaj / Vybavení / Vybavenie /  
Ugradnja / Фитинги / Uydurma / Adattamento:

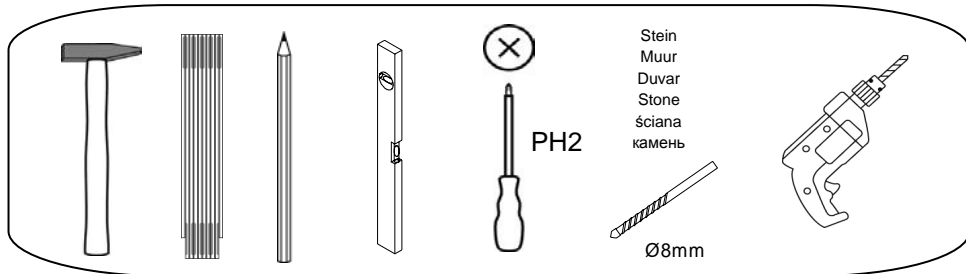
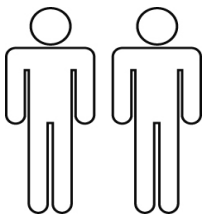

Stein  
Muur  
Duvar  
Stone  
ściana  
камень

Ø8mm

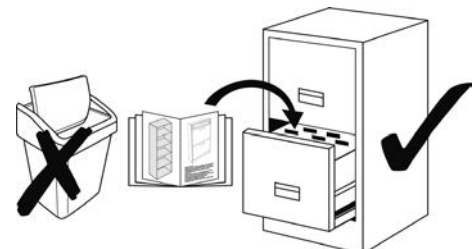
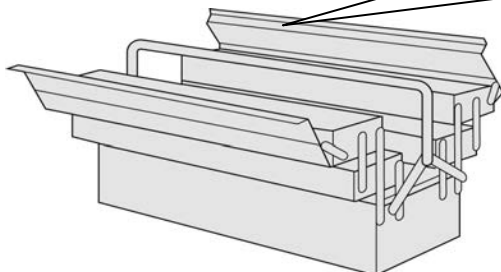

**Gesamtübersicht:  
general survey:**

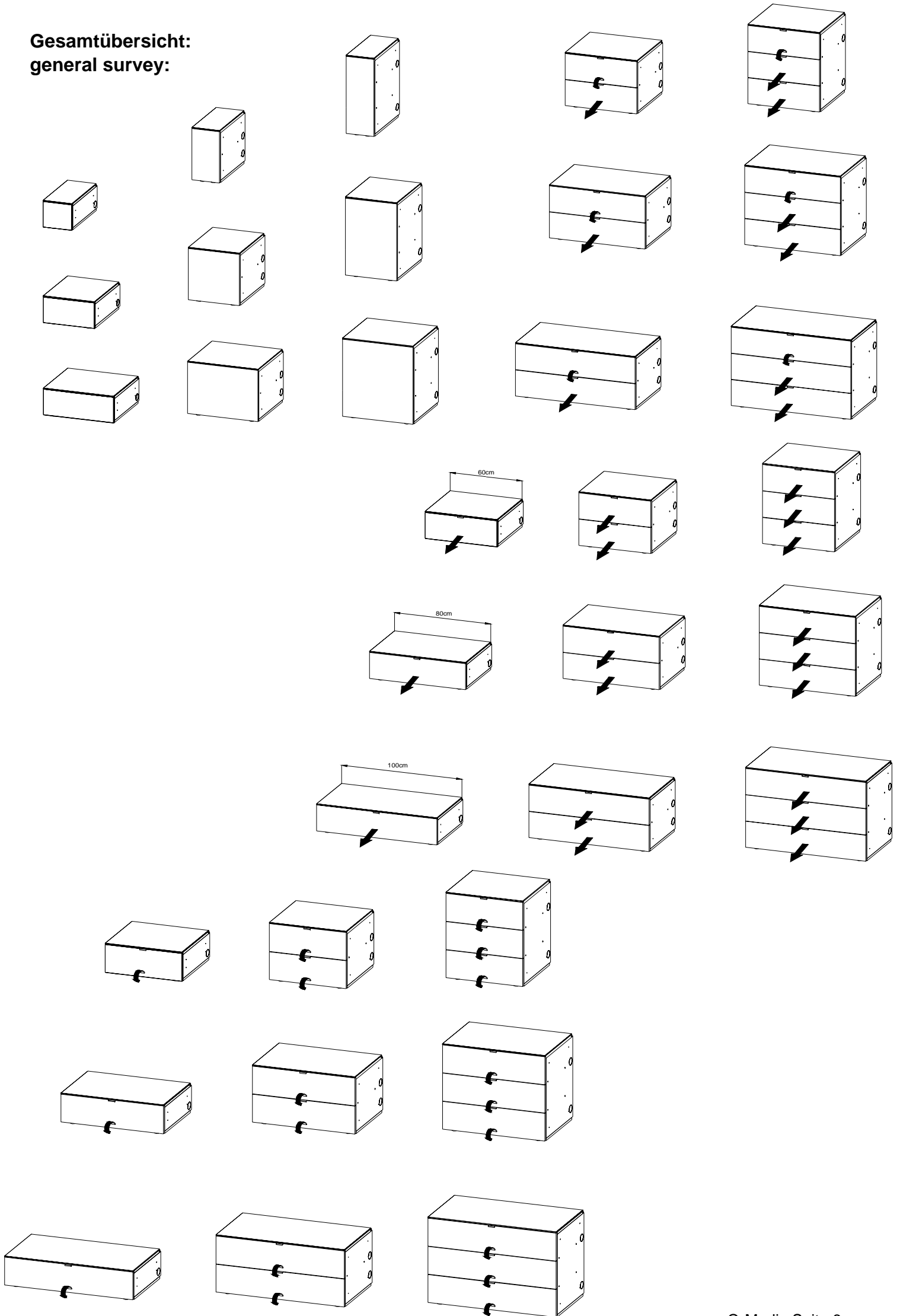

# Q-Media

Anbauelemente 2R  
mit Klappe 60 cm

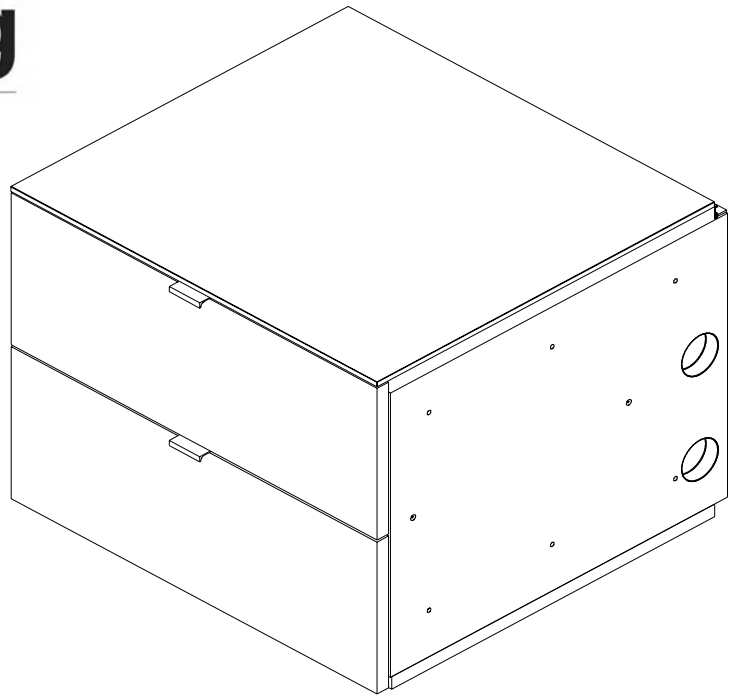

## Beschlagteile Typ 206

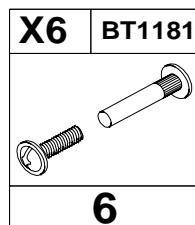
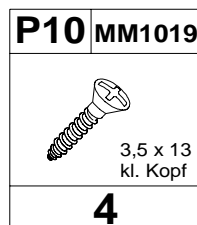
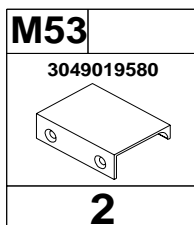

Beschlag / Fitting / Montaža / Felszerelés / Montaj / Vybavení / Vybavenie /  
Ugradnja / Фитинги / Uydurma / Adattamento:

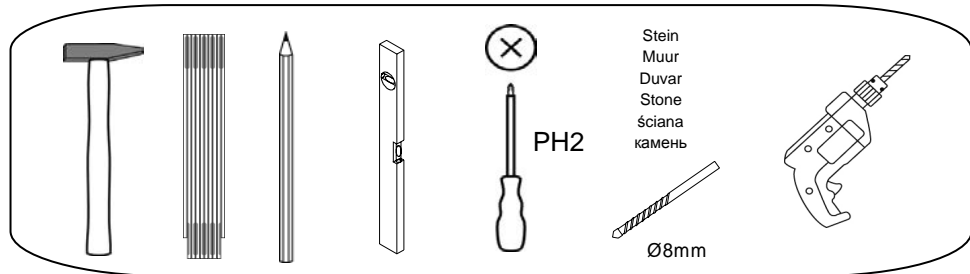
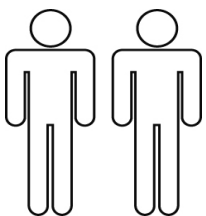

Stein  
Muur  
Duvar  
Stone  
ściana  
камень

Ø8mm

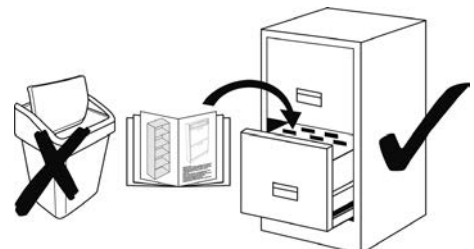
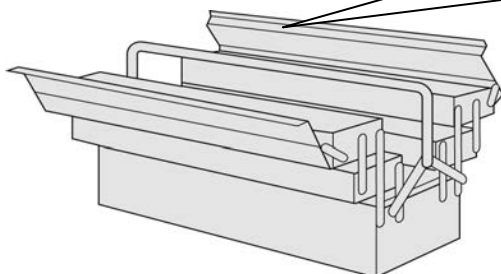



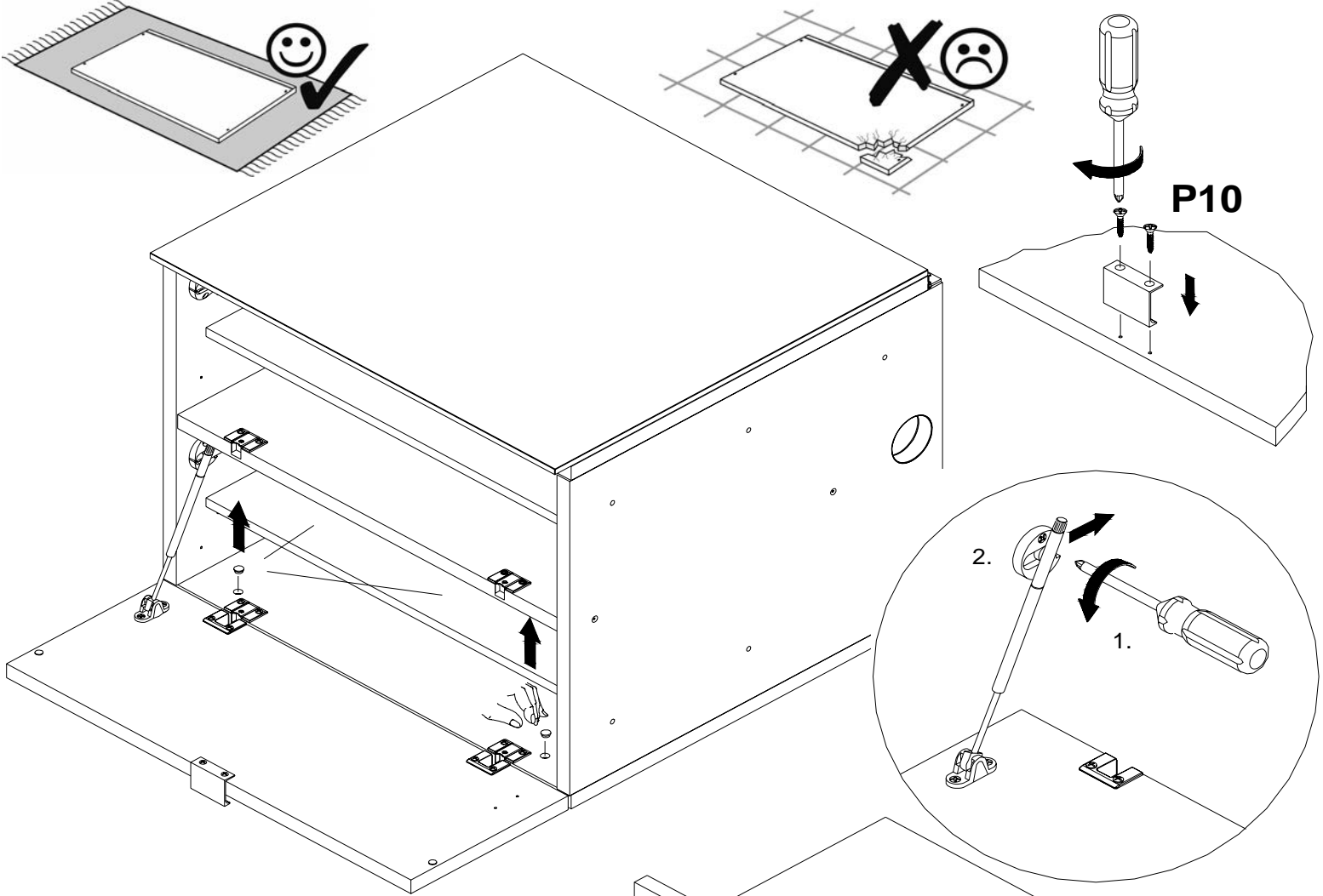

**Demontage der Tür  
siehe Seite 9 !**

**Dismounting of the door  
see page 9 !**

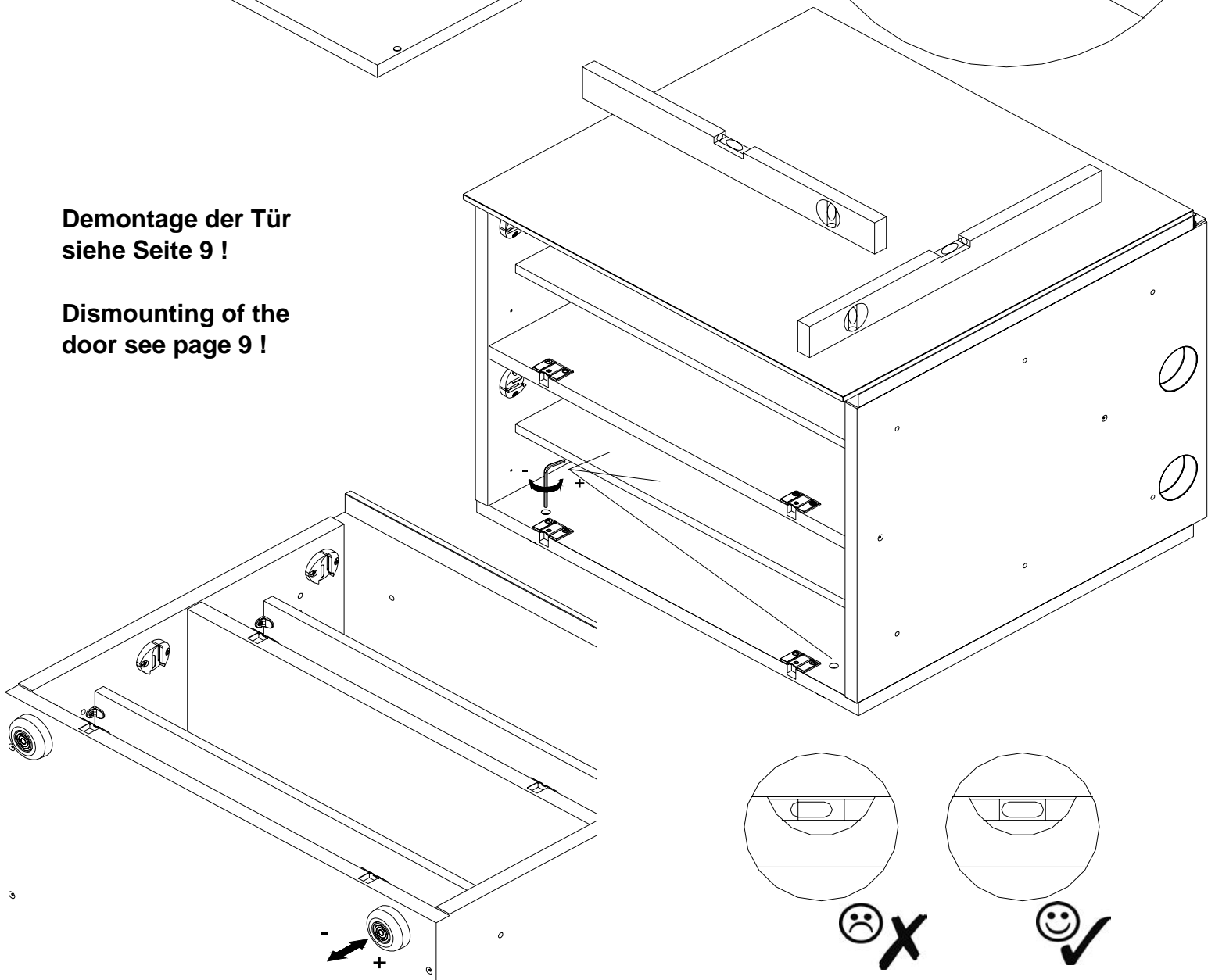



**Verstellung der Tür:  
Adjustment of the door:**



**Montage:  
Assembly:**

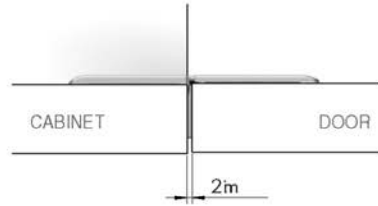
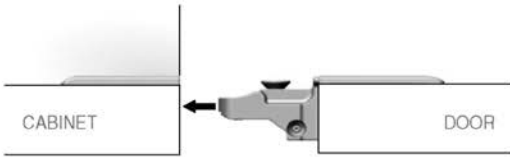

**IN-DEPTH ADJUSTMENT 0+2 mm**

⚠ TO BE MADE BEFORE LOCKING SCREW OPERATION ⚠

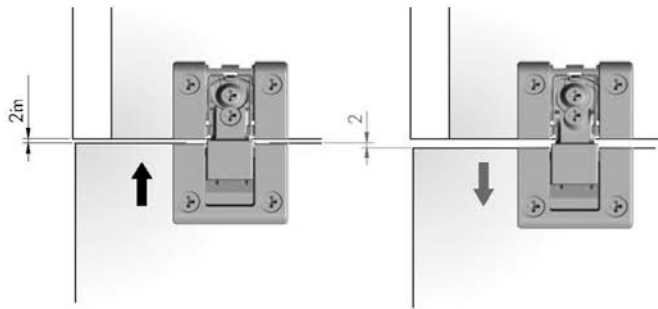

**Depth adjustment:**

**LATERAL ADJUSTMENT 0±1 mm**

⚠ TO BE MADE BEFORE LOCKING SCREW OPERATION ⚠

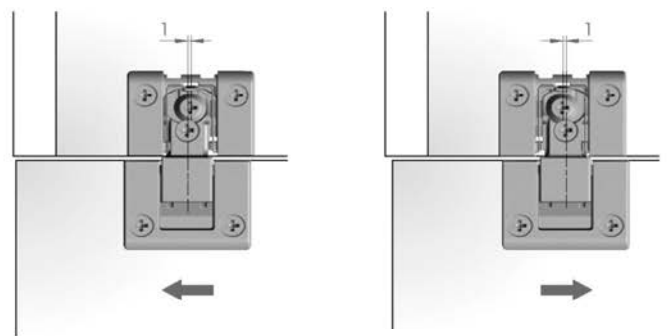

**Horizontal adjustment:**

**VERTICAL ADJUSTMENT 0+2 mm - DOOR OPEN**

⚠ TO BE MADE BEFORE LOCKING SCREW OPERATION ⚠

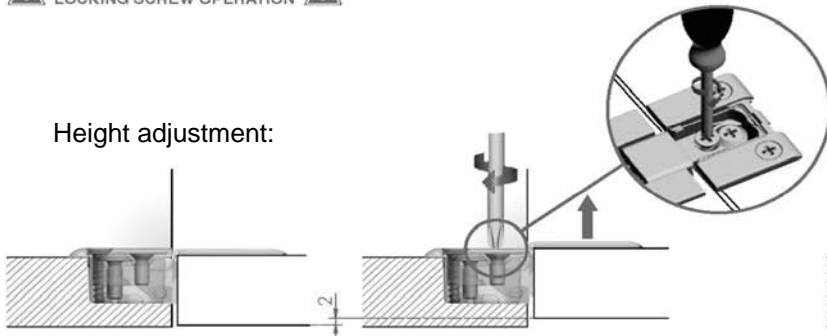

**VERTICAL ADJUSTMENT +2 mm CARRIED OUT - DOOR CLOSED**

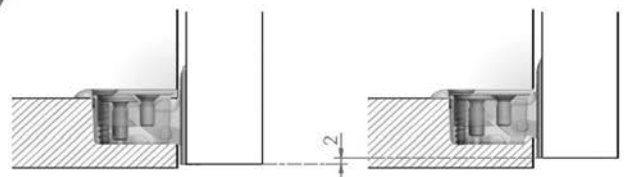

**Height adjustment:**

**Height adjustment:**

**LOCKING SCREW**

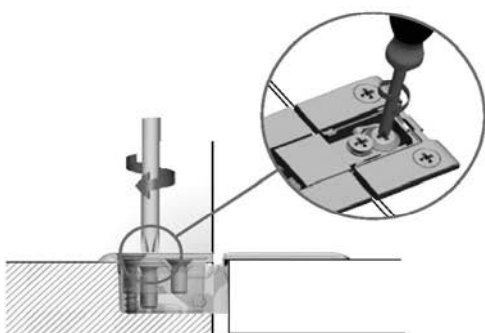

**COVER CAP INSERTION**

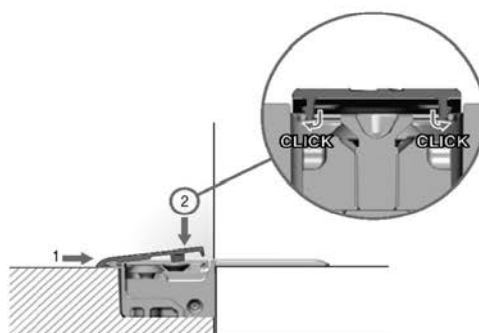

**COVER CAP REMOVAL**

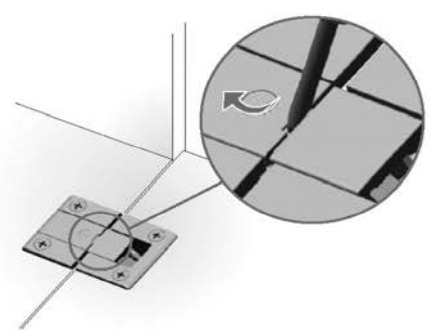

# Beschlagteile optional !

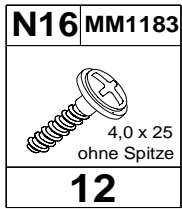

**Achtung:**  
Schrauben in  
schwarz !

**Attention:** black  
screws !

Die Schrauben zur Befestigung der Rückwand nur mit einem Handschraubendreher anziehen.  
Keinen Elektro- oder Akkuschrauber verwenden.

Only use a hand screwdriver to attach the screws .  
Do not use an electric or cordless screwdriver.

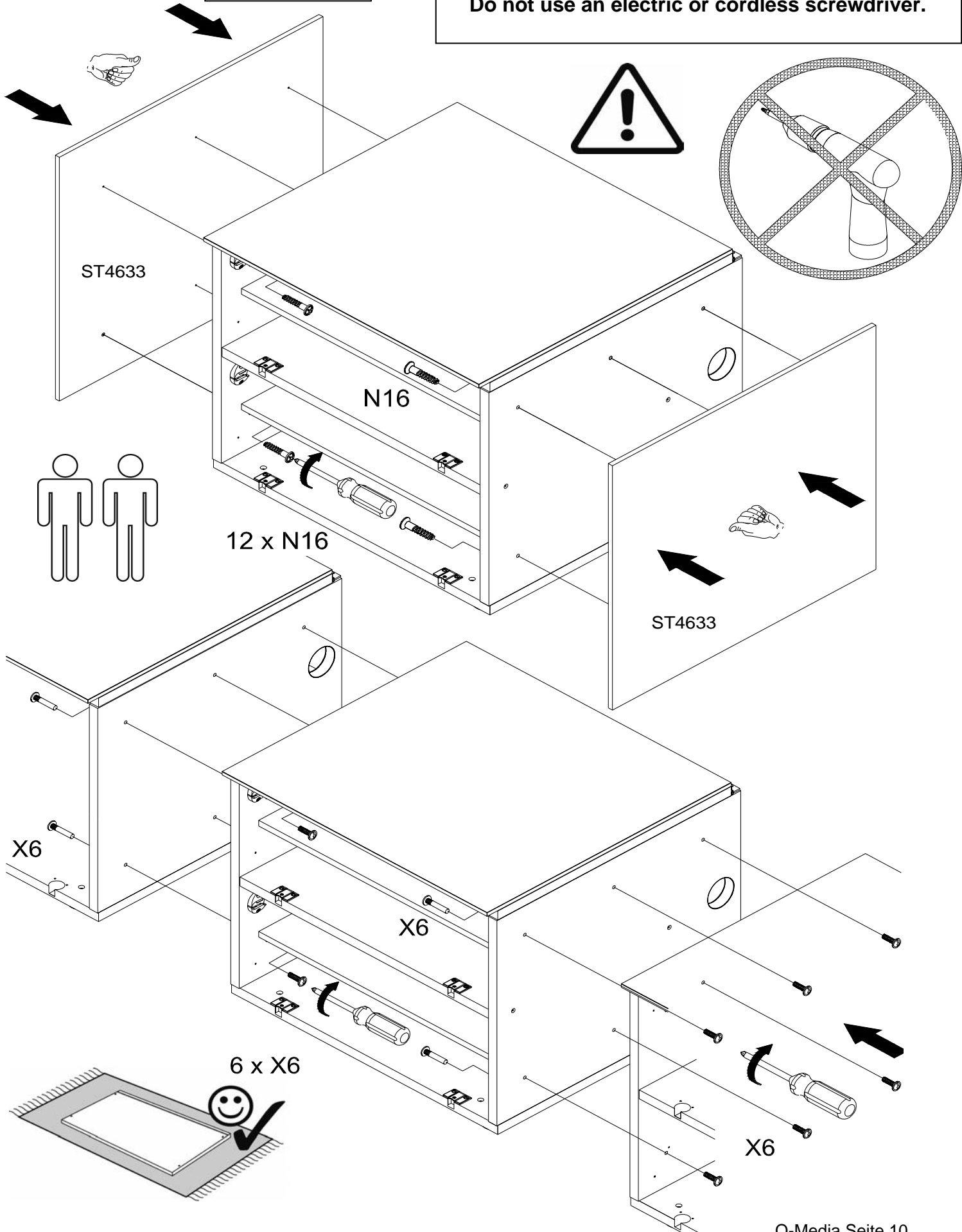

# Beschlagteile optional !

<b>N16</b>	<b>MM1183</b>
 4,0 x 25 ohne Spitze	
<b>12</b>	

**Achtung:**  
Schrauben in  
schwarz !

**Attention:** black  
screws !

Die Schrauben zur Befestigung der Seiten nur mit  
einem Handschraubendreher anziehen.  
Keinen Elektro- oder Akkuschrauber verwenden.

Only use a hand screwdriver to attach the screws .  
Do not use an electric or cordless screwdriver.

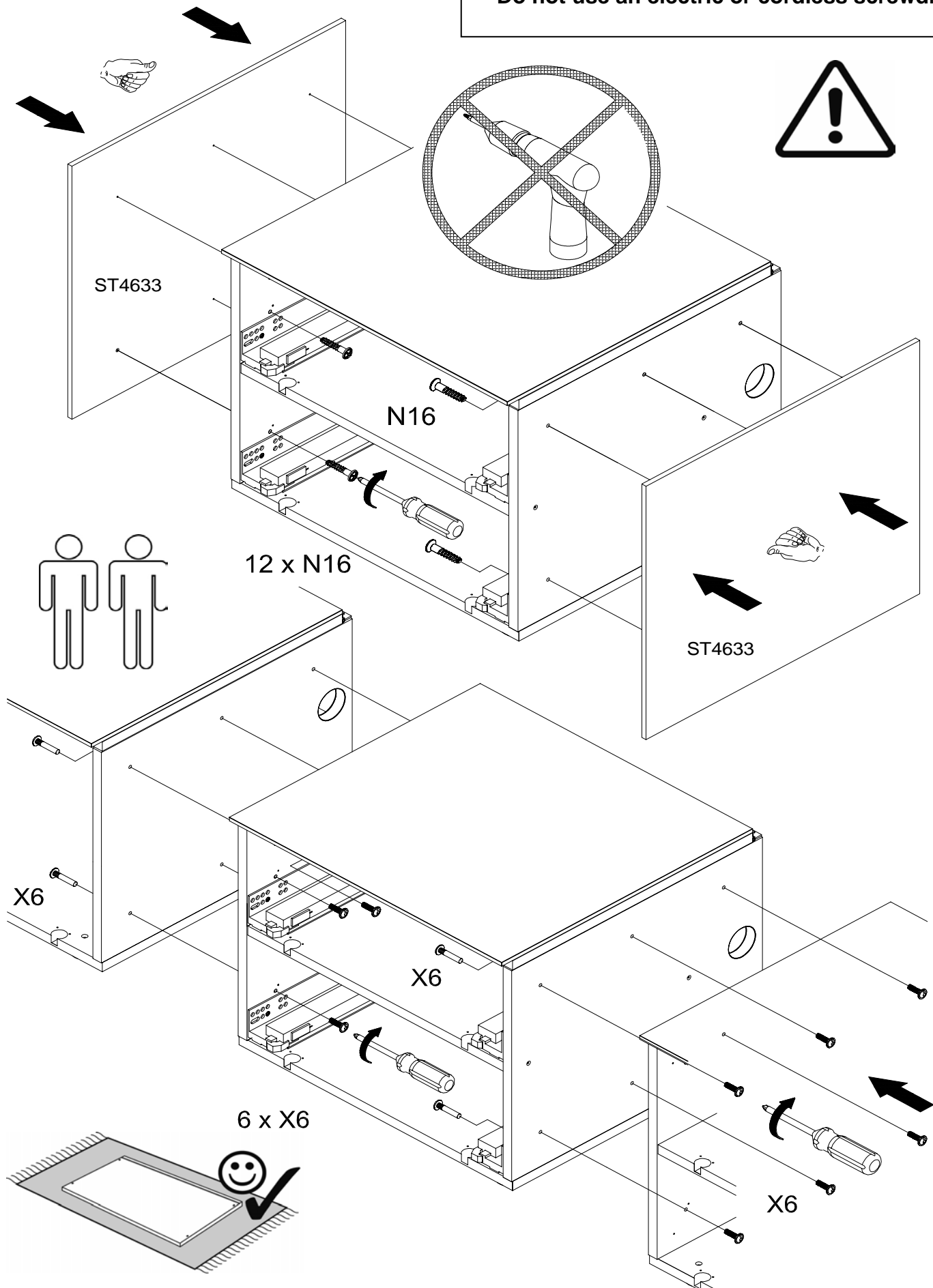

# Beleuchtung optional !

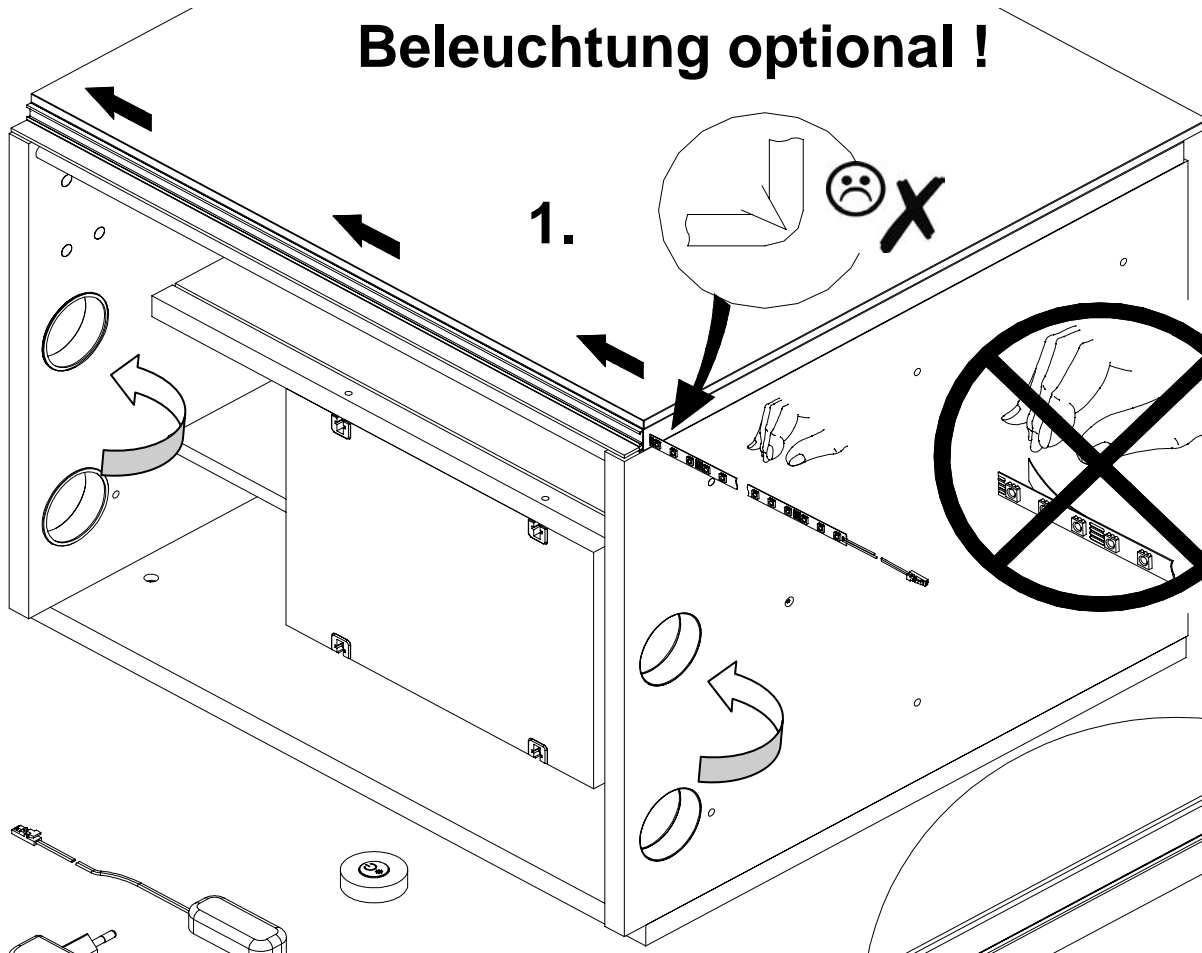
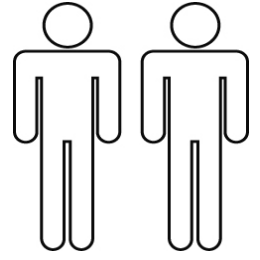

1.

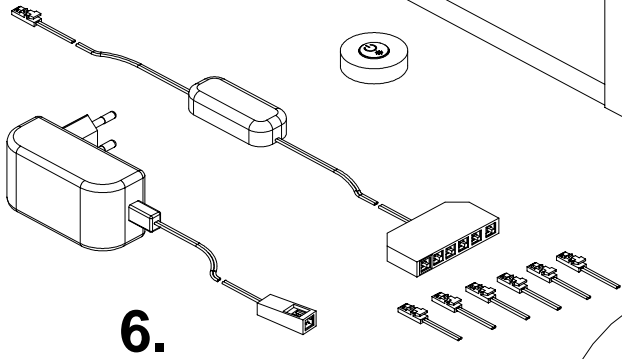
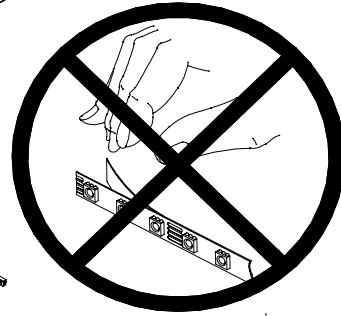

6.

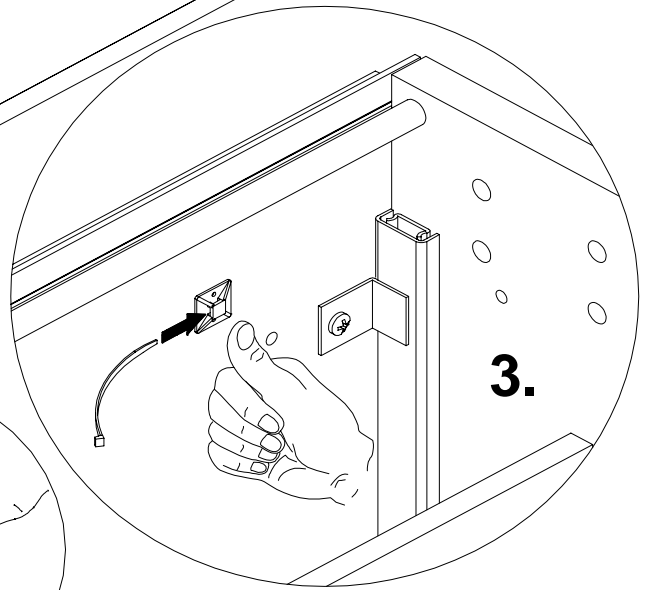

3.

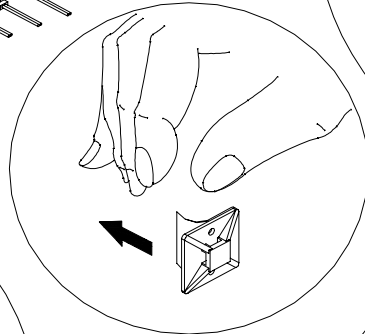

2.

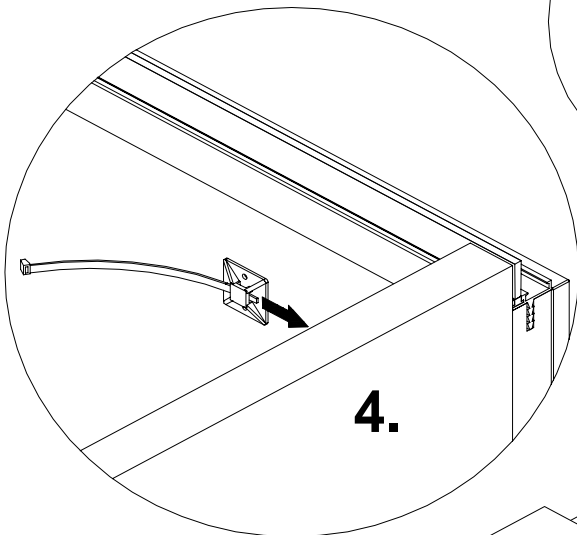

4.

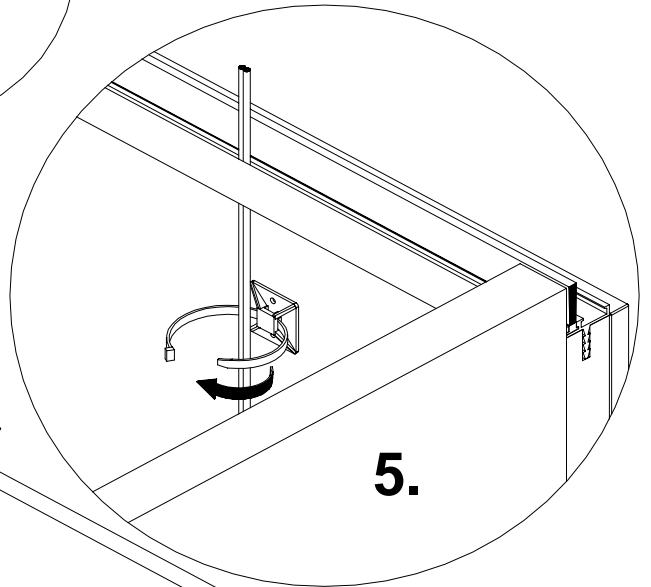

5.

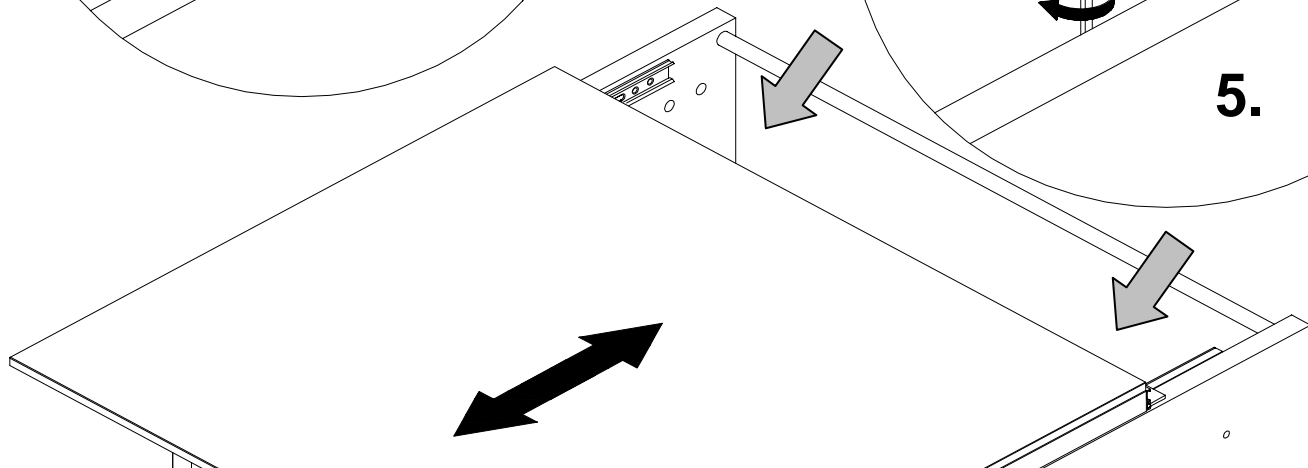



# Aufhängung optional !

Beschlagteile 2er Hänger 3500000000001106

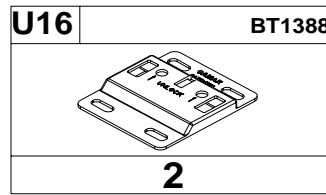
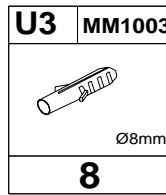
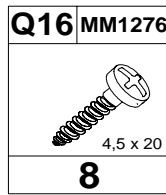
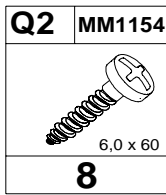
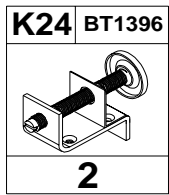
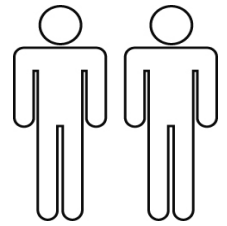

Sehr geehrte Kundin, sehr geehrter Kunde,

Das beigefügte Wandbefestigungsmaterial (Dübel und Schrauben) eignet sich nur für festes Mauerwerk (z.B. Beton- oder Ziegelwände). Für andere Wandaufbauten sind eventuell Spezialdübel und andere Schrauben notwendig. Ziehen Sie gegebenenfalls eine Fachkraft zurate. Technische Änderungen vorbehalten.

Dear customer,

the provided mounting material (dowels and screws) can only be used with solid masonry (e.g. concrete or brick walls). For other wall constructions special dowels and screws are needed. Please consider an expert in these cases. Leaving technical changes.

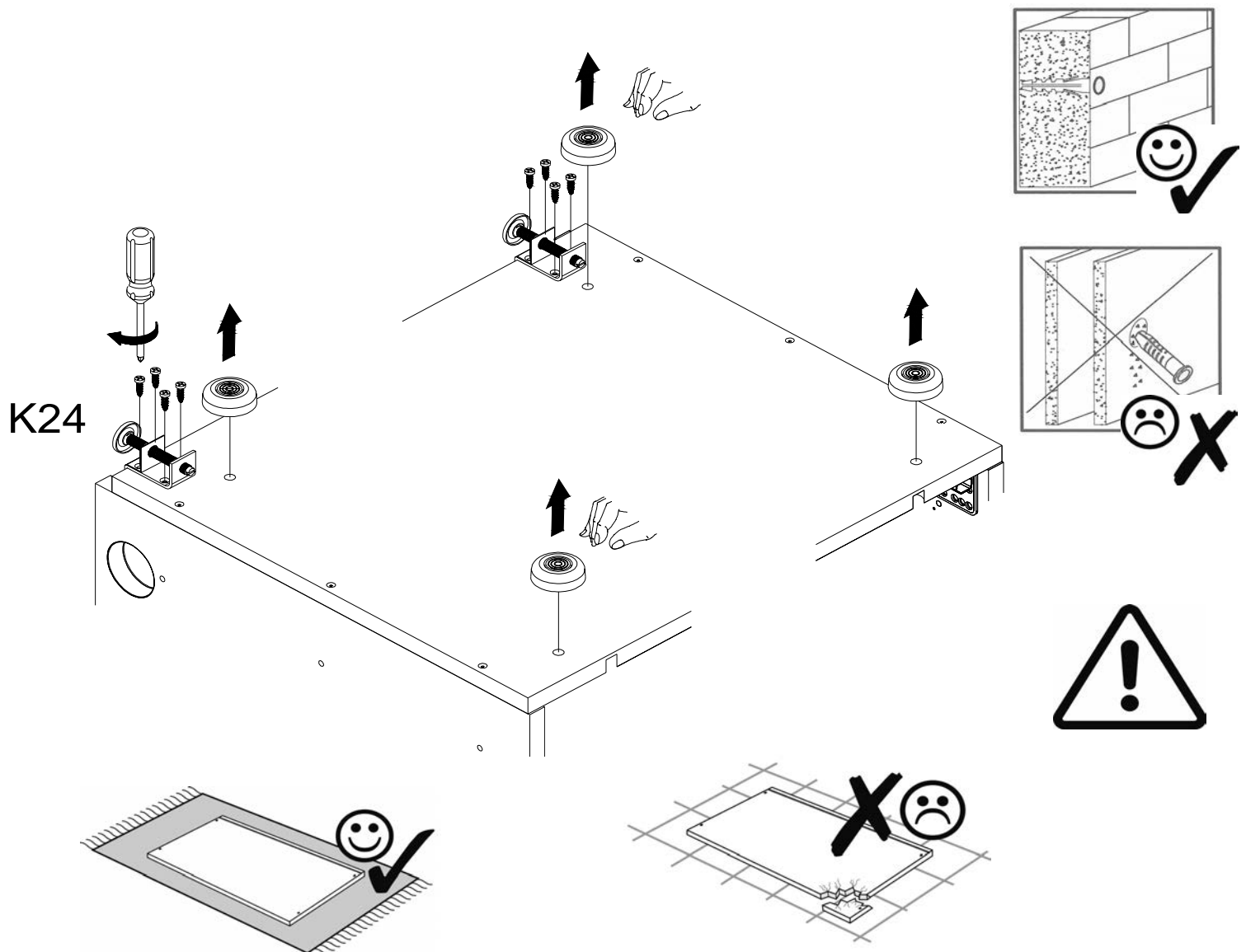

Empfohlene Montagehöhe: 64,8cm Oberkante Korpus.

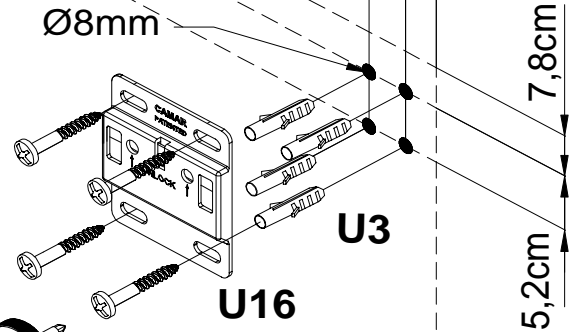
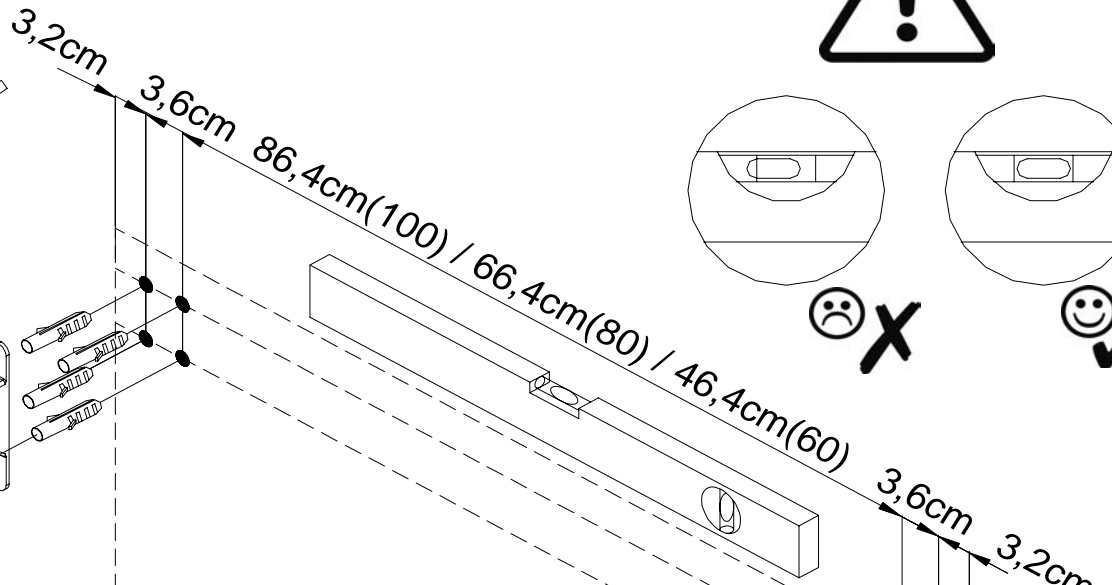
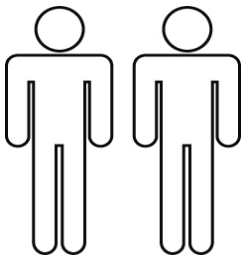
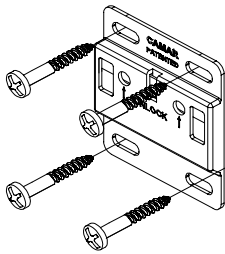
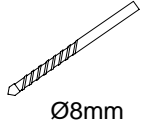
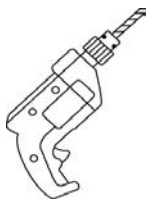
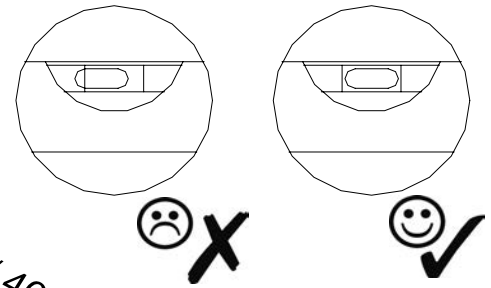

96,0cm / 76,0cm / 56,0cm !

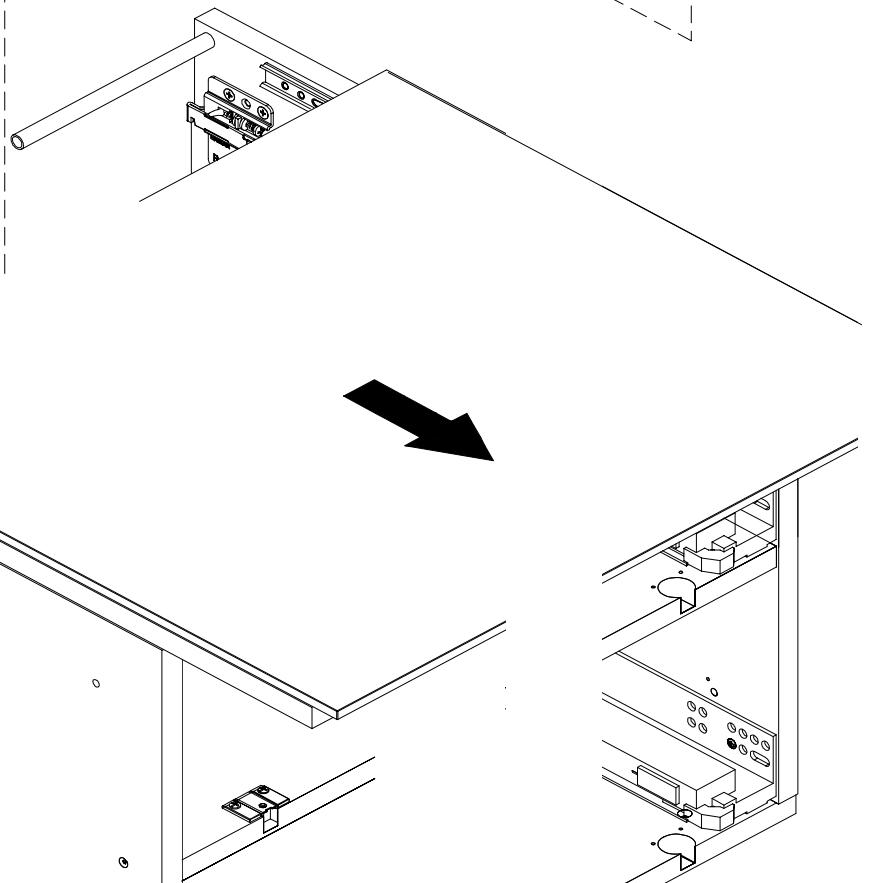
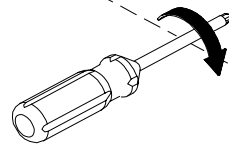
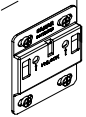

**Montage:  
Assembly:**

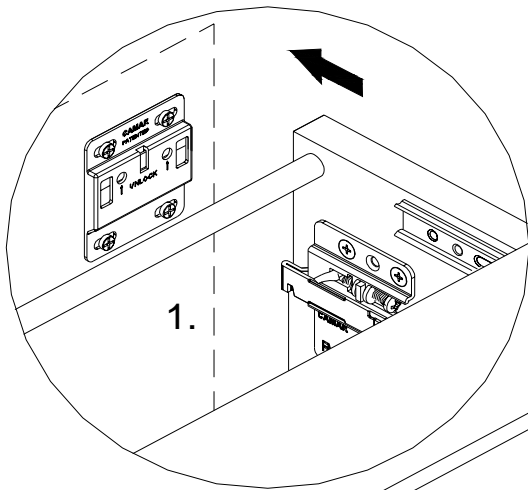

1.

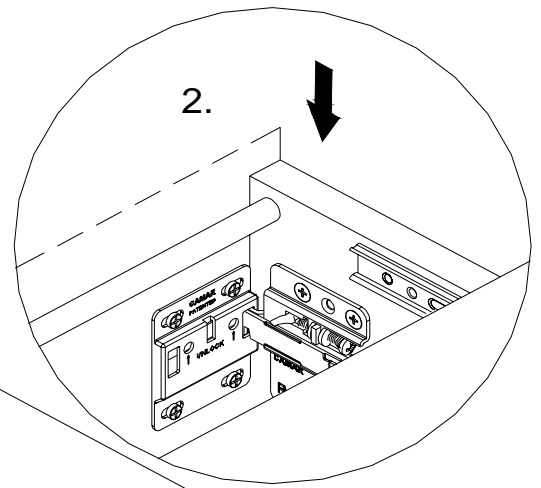

2.

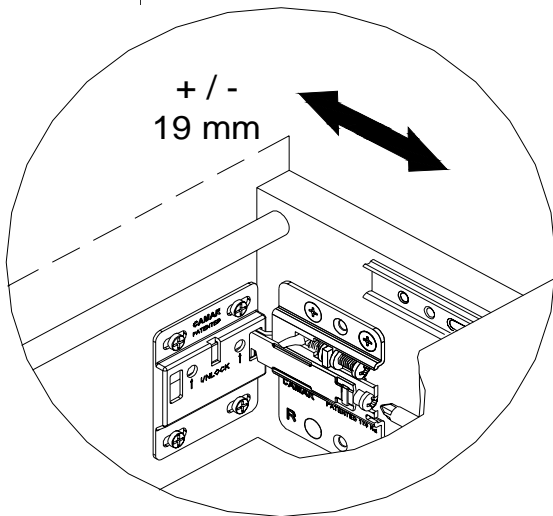
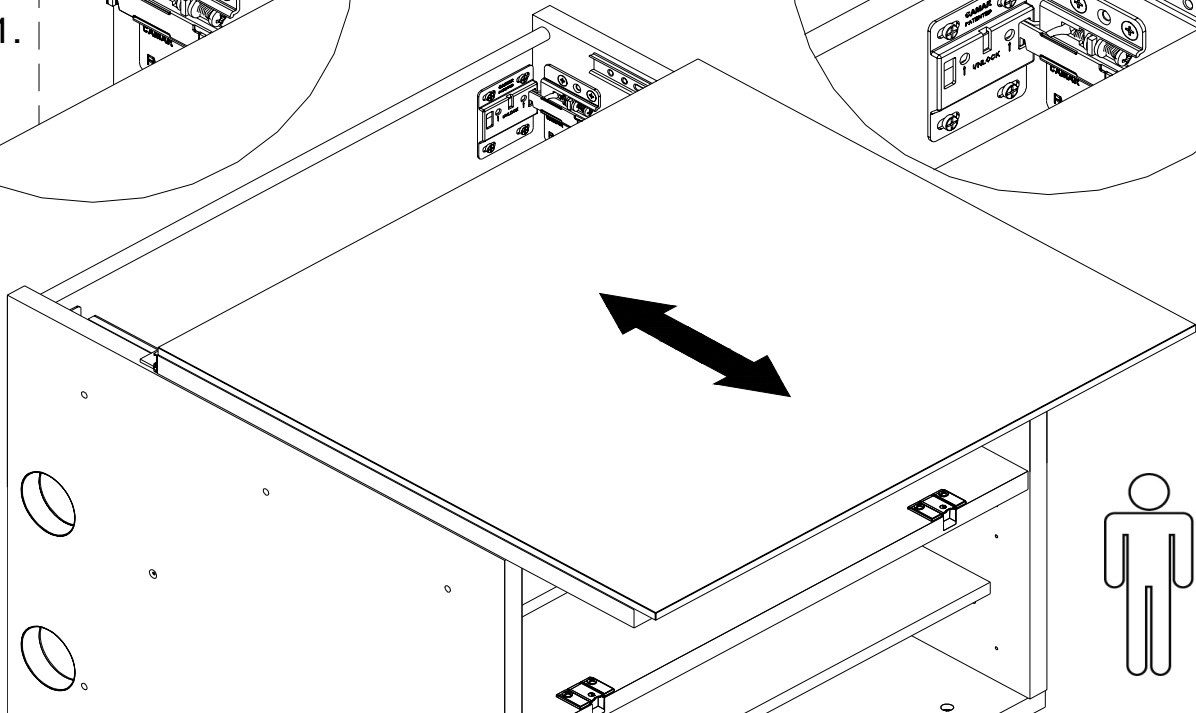

+ / -  
19 mm

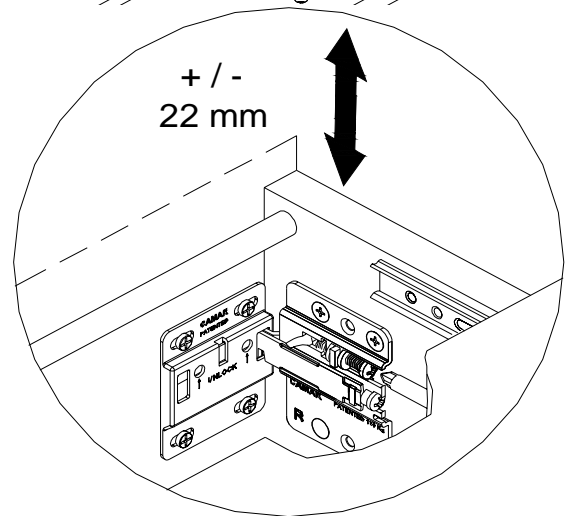

+ / -  
22 mm

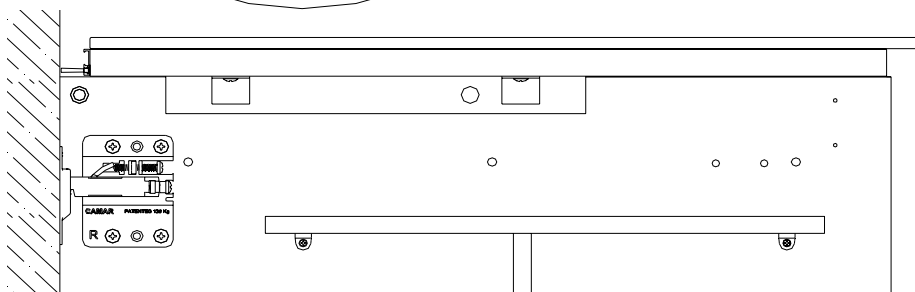

90°

**Ausrichten des Hängeschrankes  
durch die Stellschrauben am  
Aufhängebeslag:  
Adjustment of the wall cupboard  
with set-screws on the fitting:**

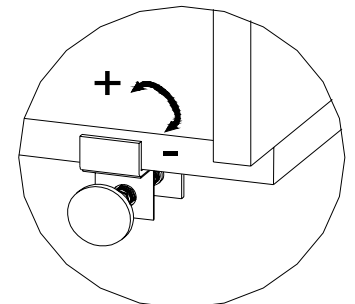

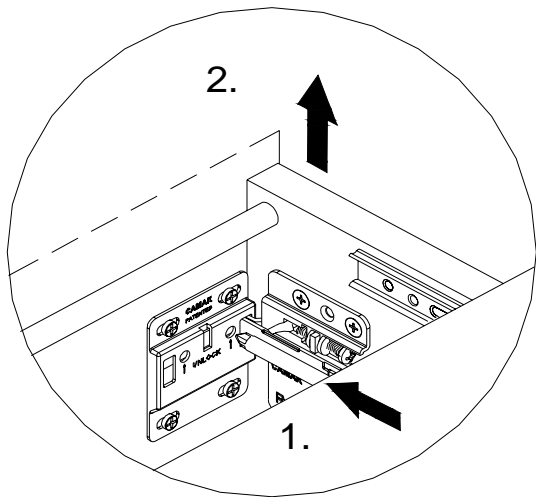

**Demontage:  
Dismounting:**

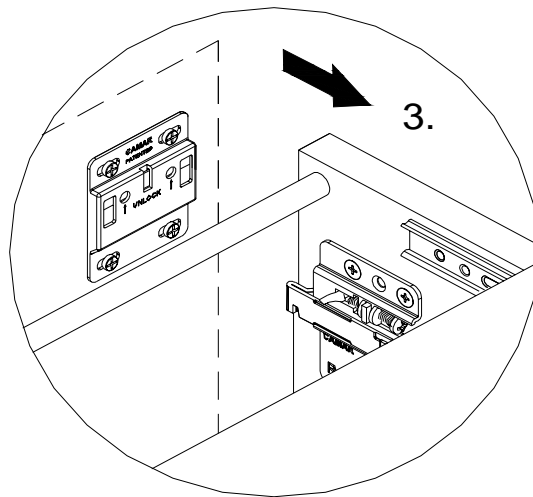

**max. 39kg**

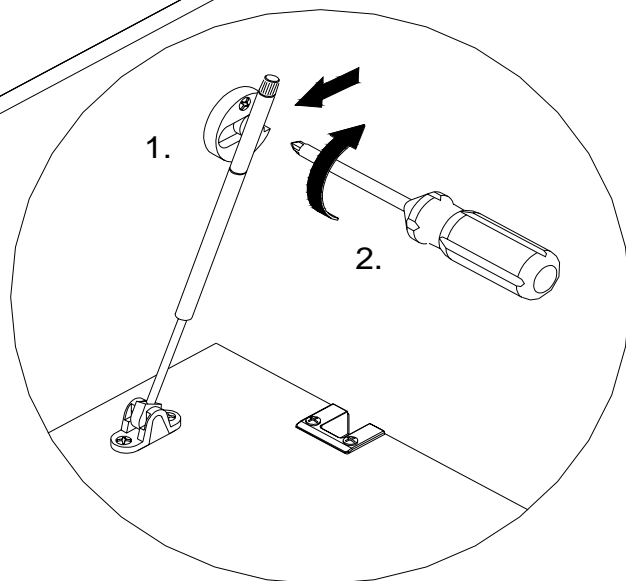
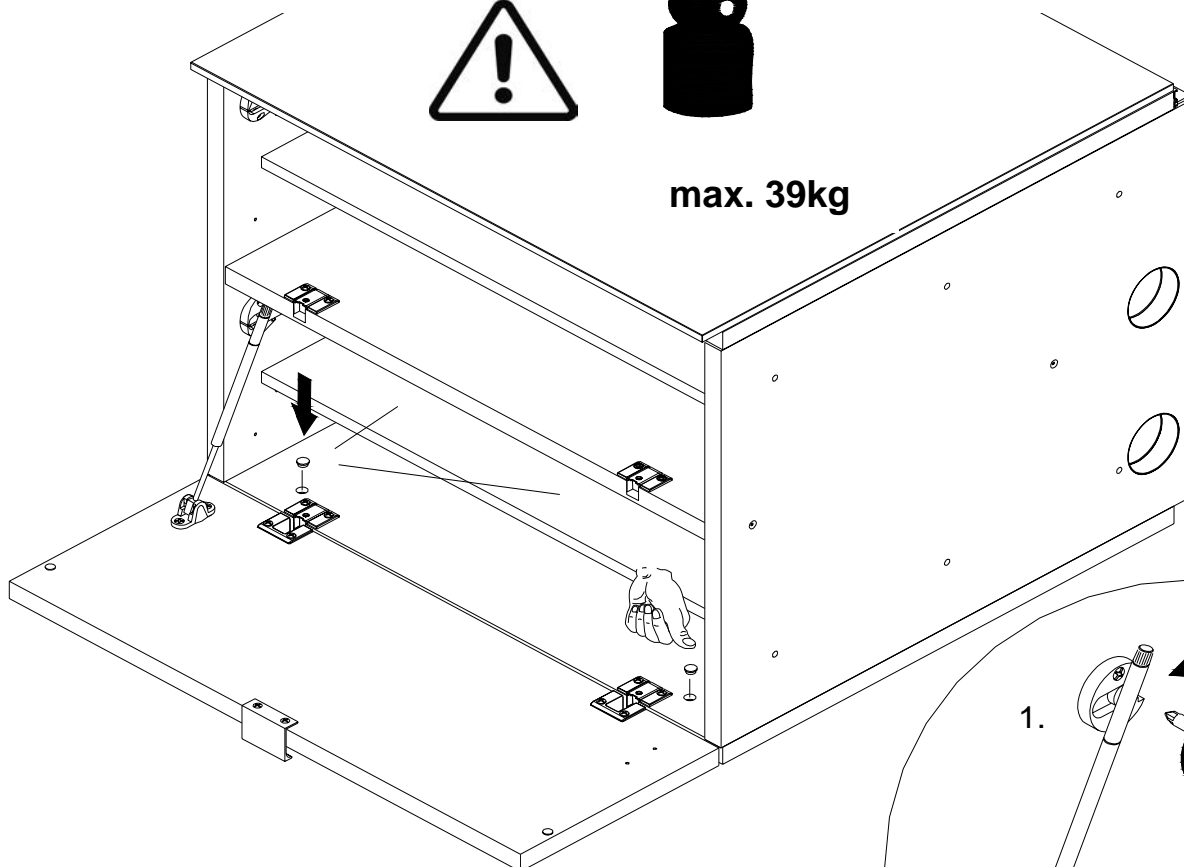
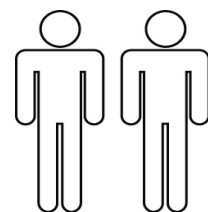

**Montage der Tür siehe Seite 3 !  
Assembly of the door see page 3 !**

**ADJUSTMENTS**

FRONT TO BACK ADJUSTMENT 0 - 10 mm

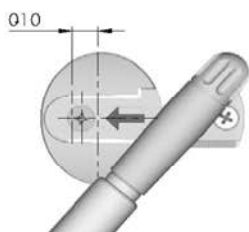

LOCKING

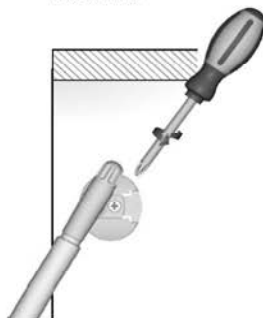

OPEN ANGLE ADJUSTMENT 0 - 10 mm

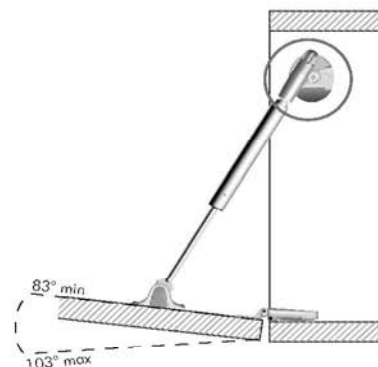
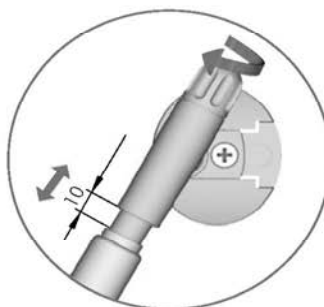

**VERY IMPORTANT**

The side bracket has to be placed with the slot in a horizontal position and the open end facing the wall. The opening of the door can be changed by adjusting the position of the piston base plate within the slot:

- Forwards adjustment = the door opens automatically later.
- Backwards adjustment = the door opens automatically in advance.

# Q-Media

Anbauelemente 2R  
mit Schubkasten 60 cm

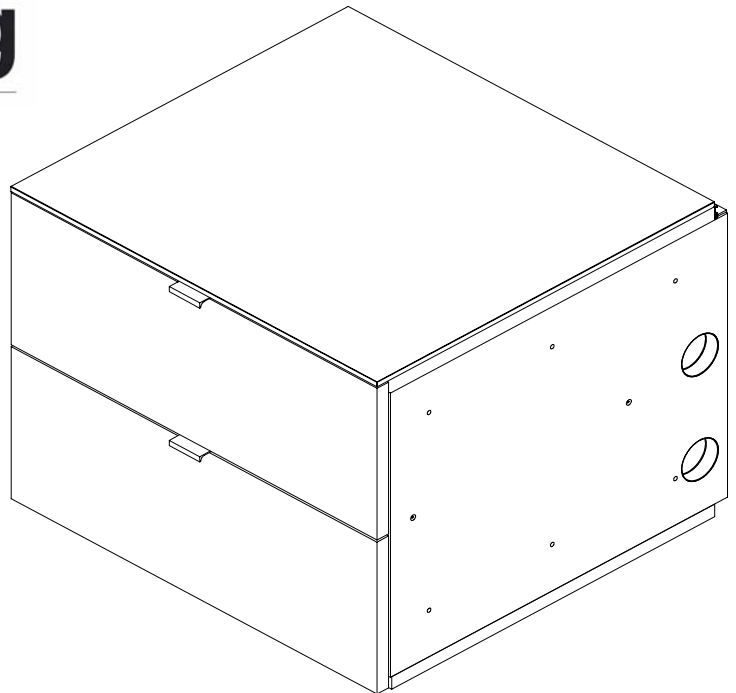

## Beschlagteile Typ 206

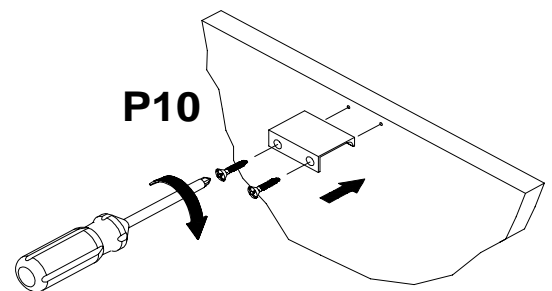
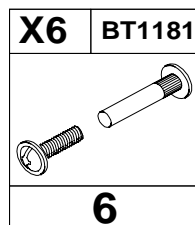
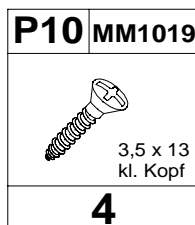
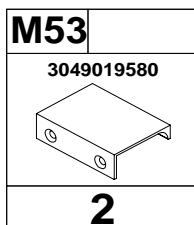

Beschlag / Fitting / Montaža / Felszerelés / Montaj / Vybavení / Vybavenie /  
Ugradnja / Фитинги / Uydurma / Adattamento:

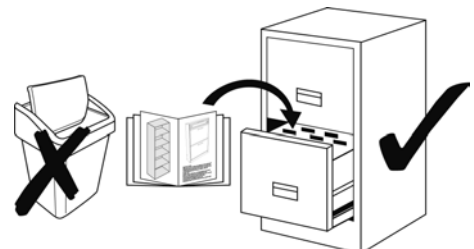
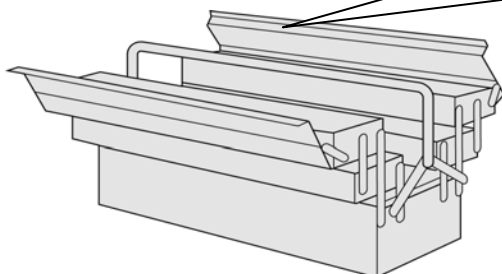
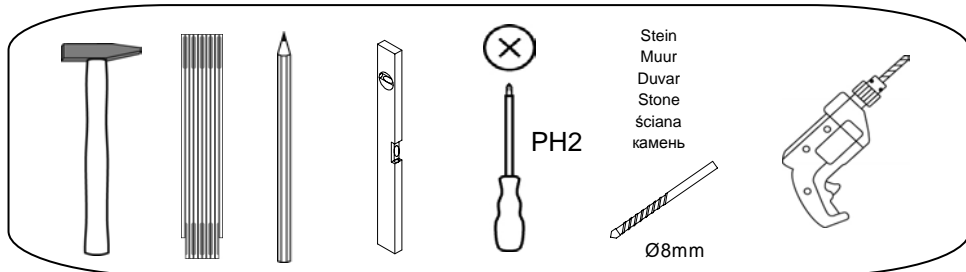
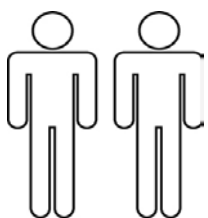



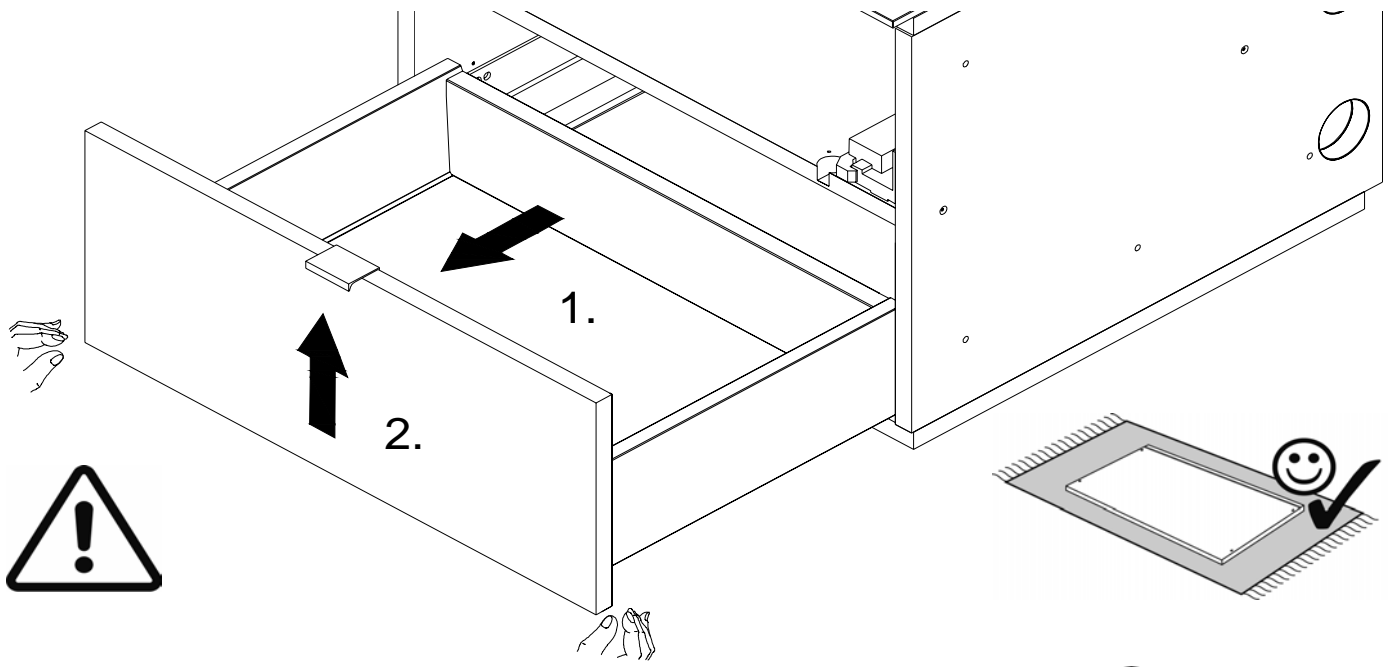

**Demontage des Schubkasten**  
**Dismounting of the drawer**

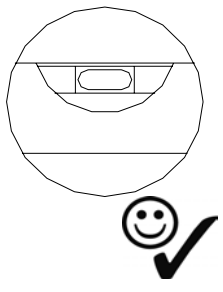
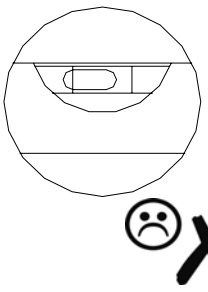
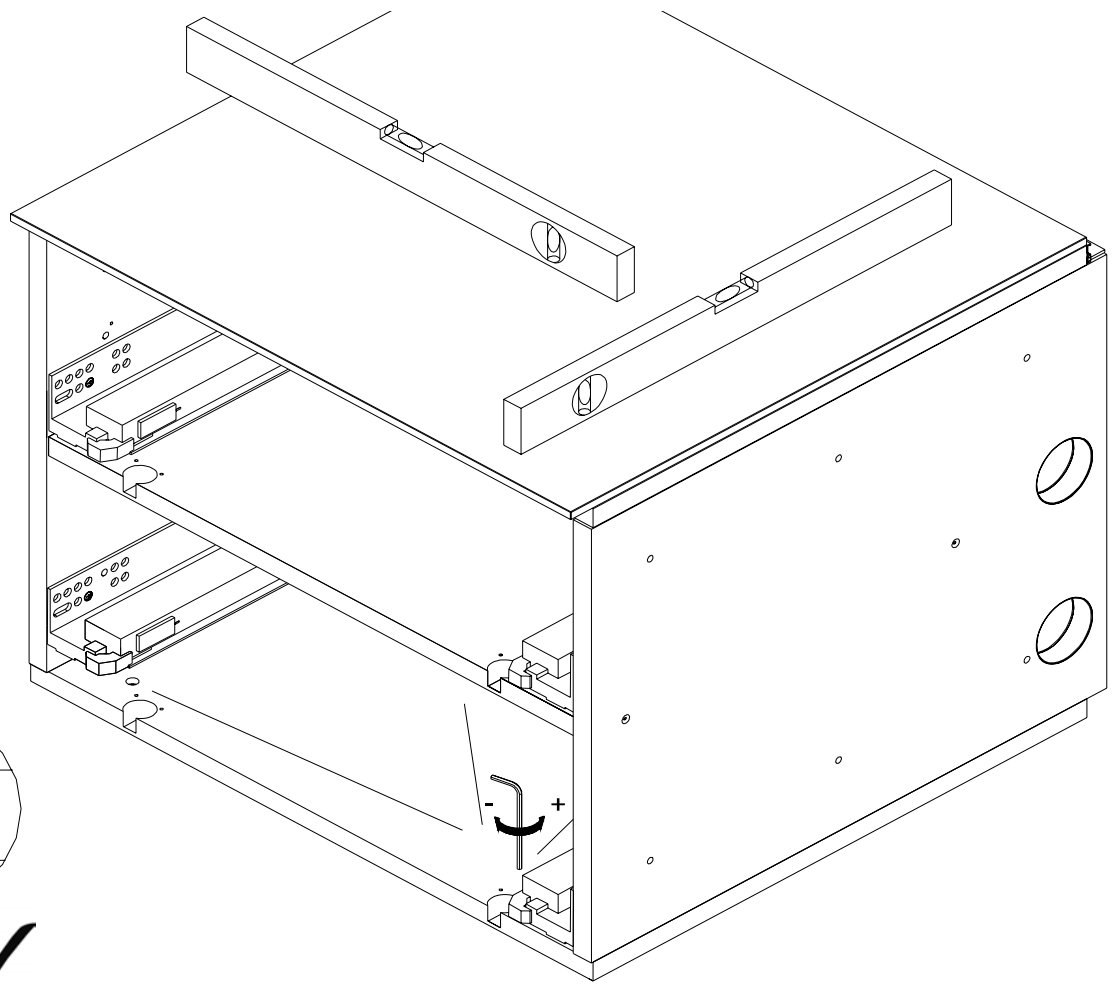
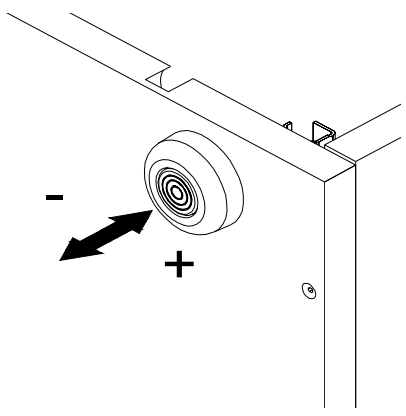
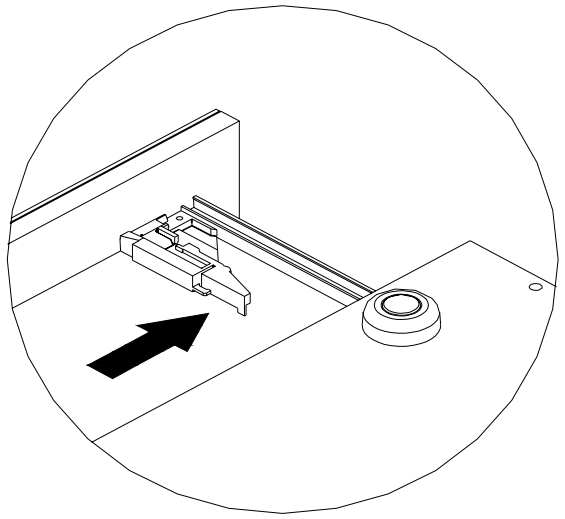
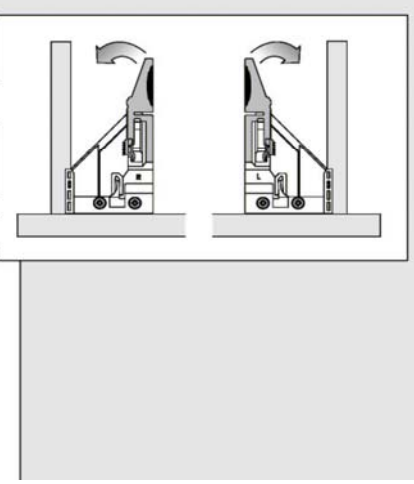
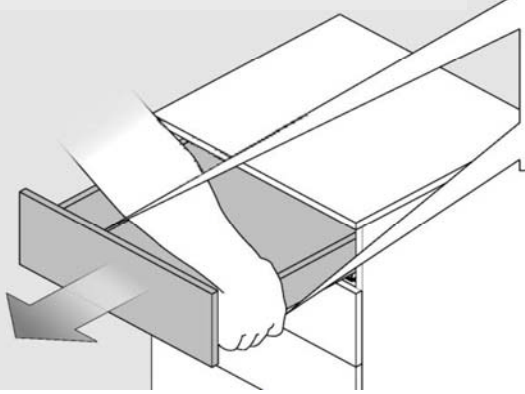

**Demontage der Front  
Dismounting of the Front**

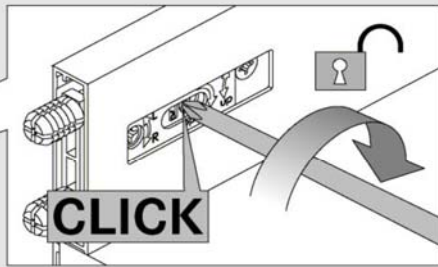
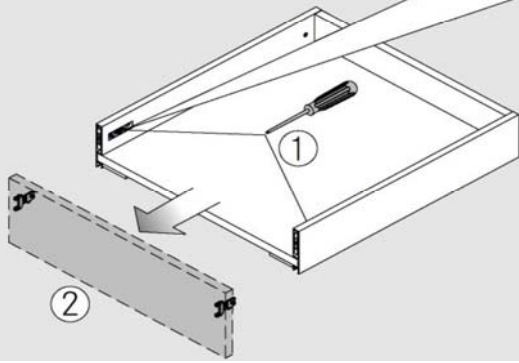

**Verstellung der Front:  
Adjustment of the Front:**

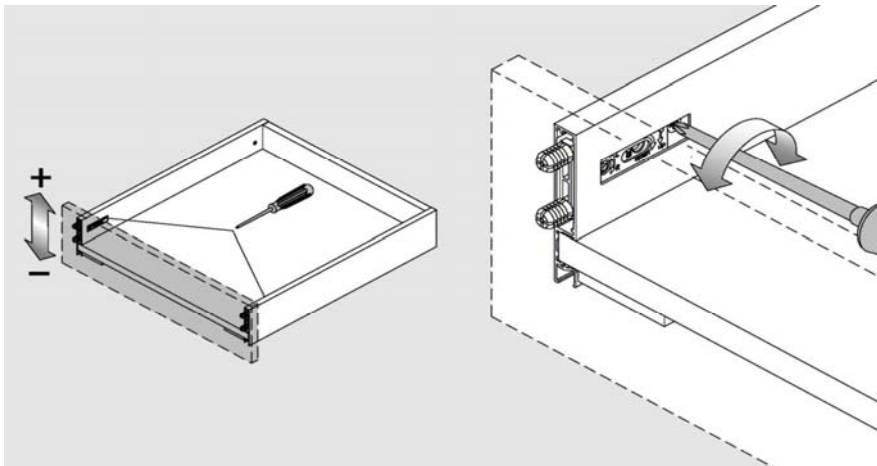
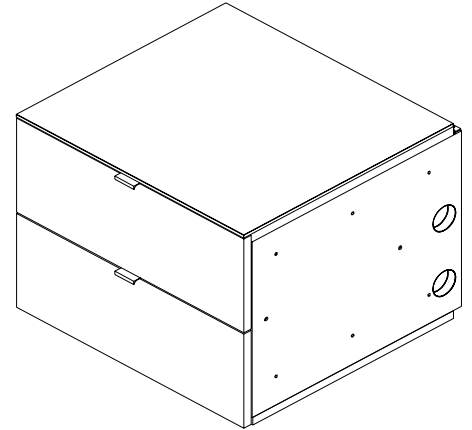

**Height adjustment:**

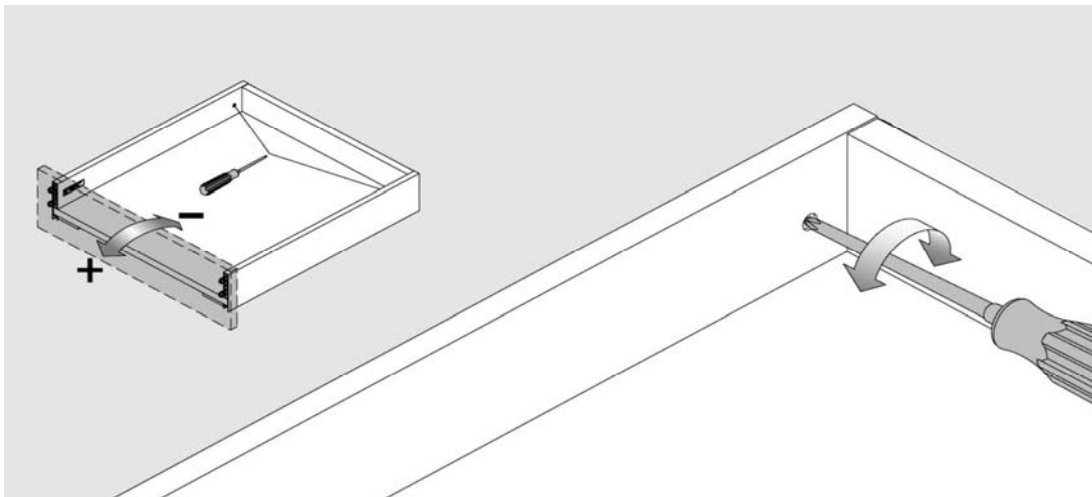

**Tiped adjustment:**

**Auf beiden Seiten vornehmen/Adjust both sides/  
À faire des deux côtés/Eseguire su entrambi i lati/  
Realizar a ambos lados/Görs på båda sidorna**

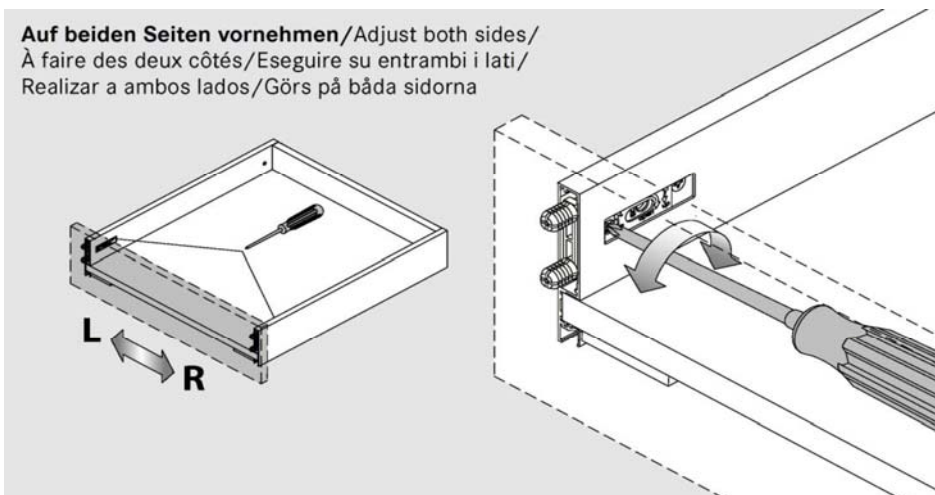

**Horizontal adjustment:**

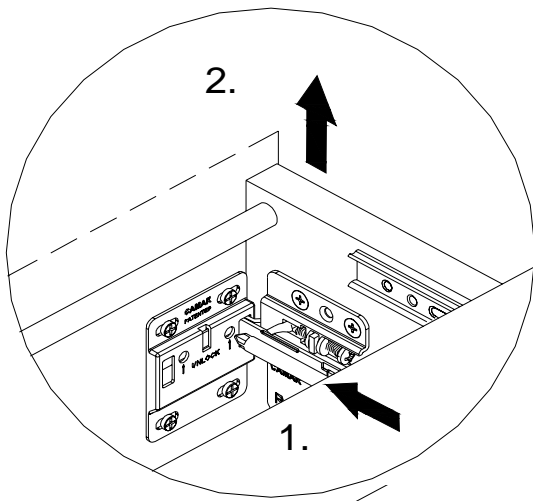

**Demontage:  
Dismounting:**

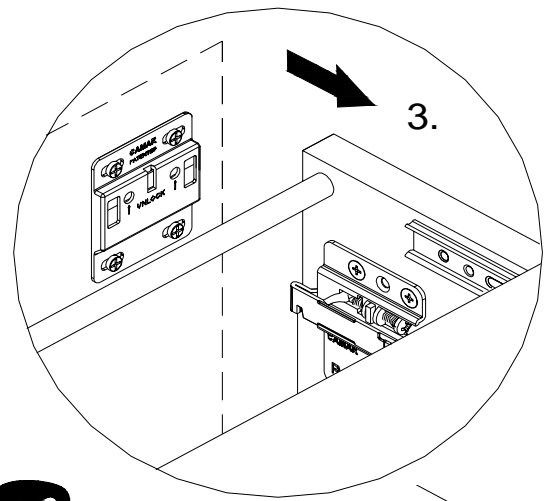

**max. 39kg**

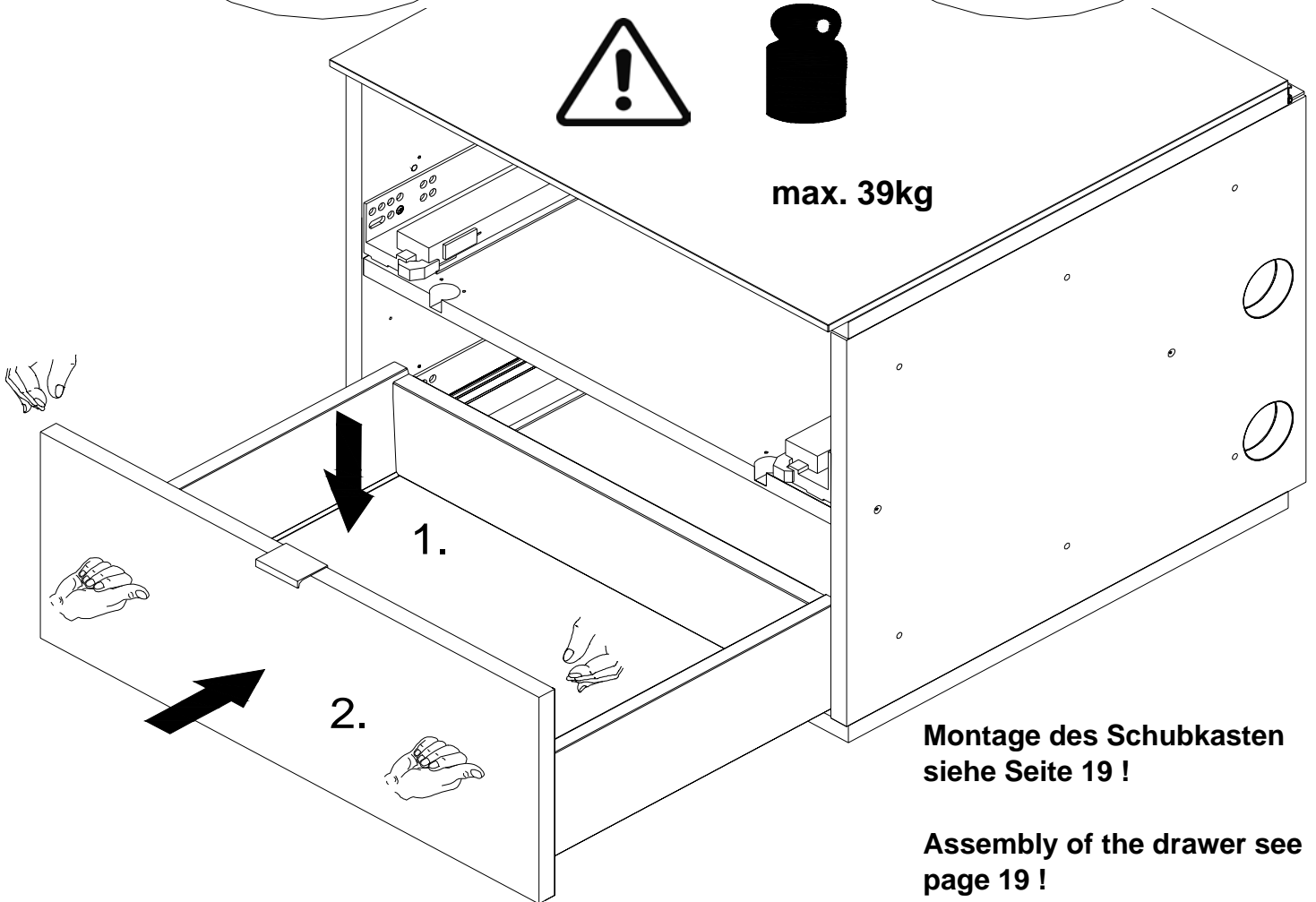

**Montage des Schubkasten  
siehe Seite 19 !**

**Assembly of the drawer see  
page 19 !**

**Montagehinweis:**

Die Auszüge in den Korpus hinein schieben, wie bei geschlossener Stellung. Dann den Stahl-Schubkasten auf die Auszüge legen und fest in den Schrank schieben, bis das System einrastet.

**Assembly note:**

Put the Sliding statements into the cupboard as in the case of closed position. Putting then the steel drawer on the statements and sliding into the cupboard tightly until the system clicks in.

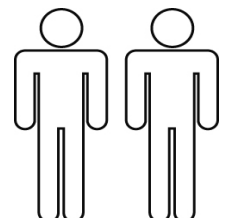
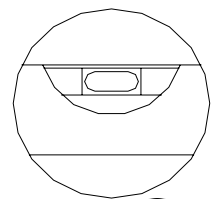
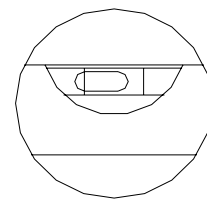

**Montage - Tipps zur Installation !**

**Assembly tips for the installation!**

**max. 39 kg**

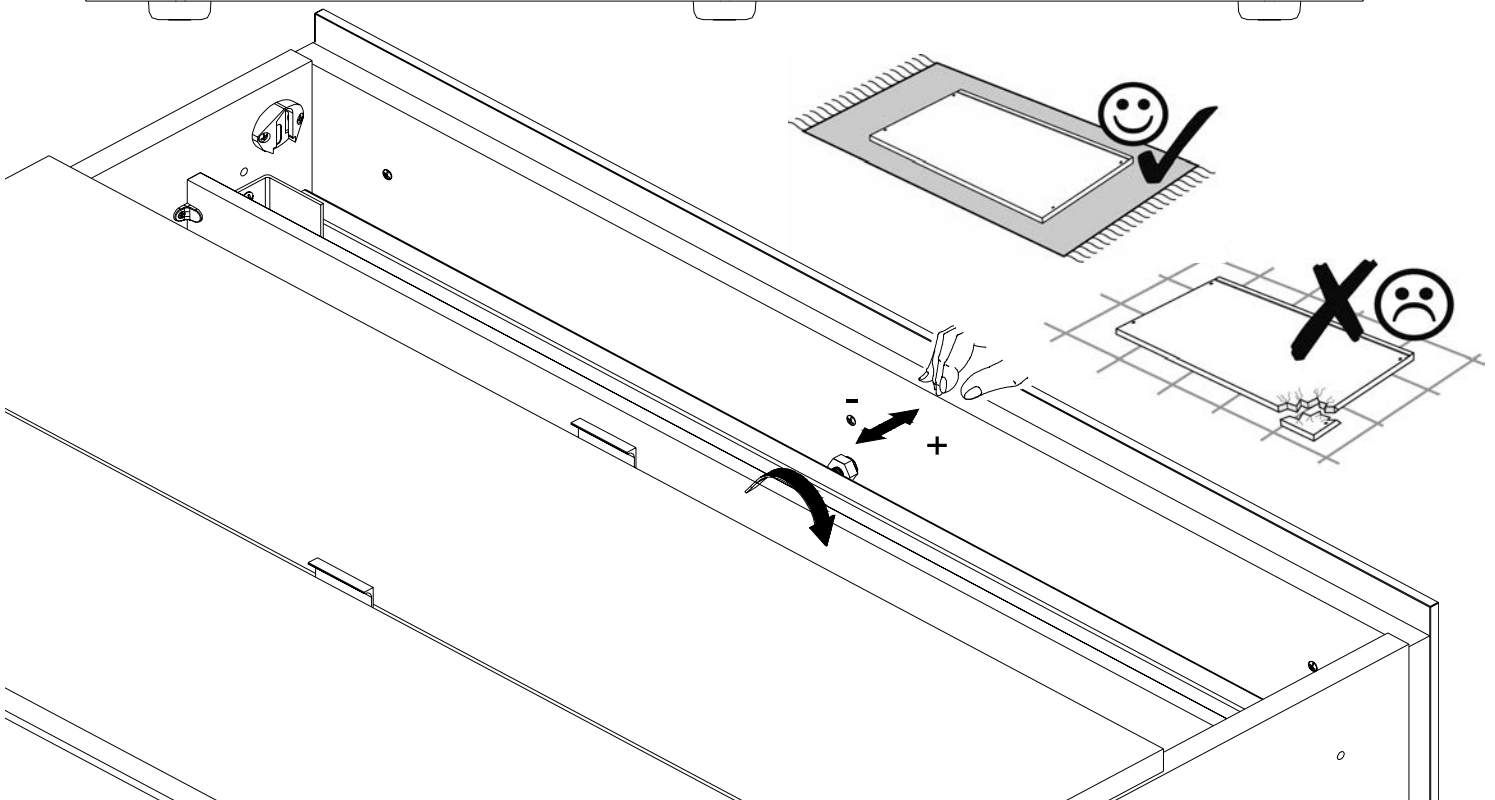
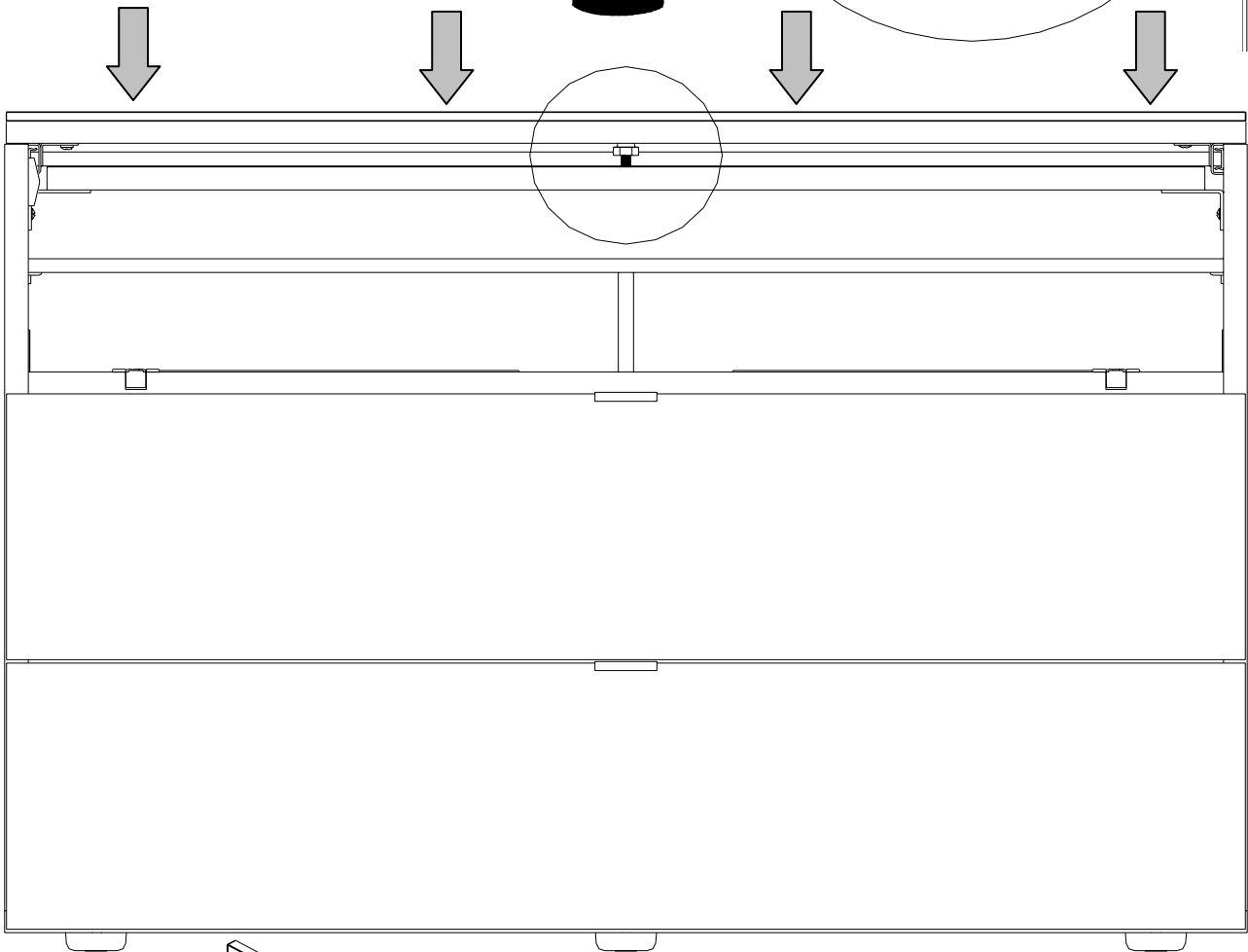
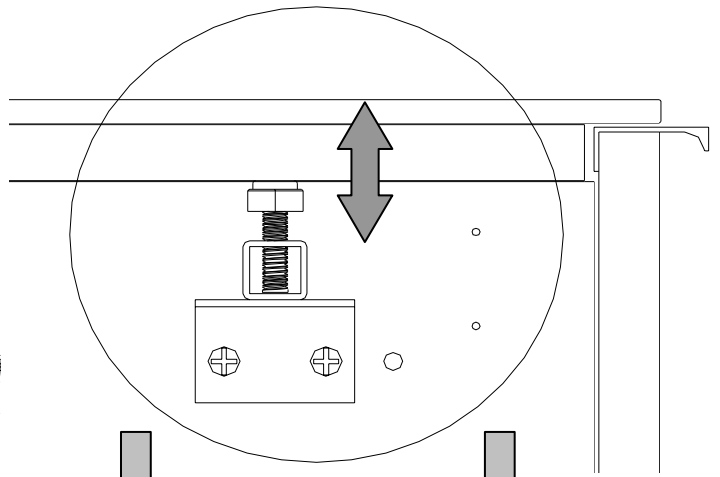

**Montage - Tipps zur Installation !**

**Assembly tips for the installation!**

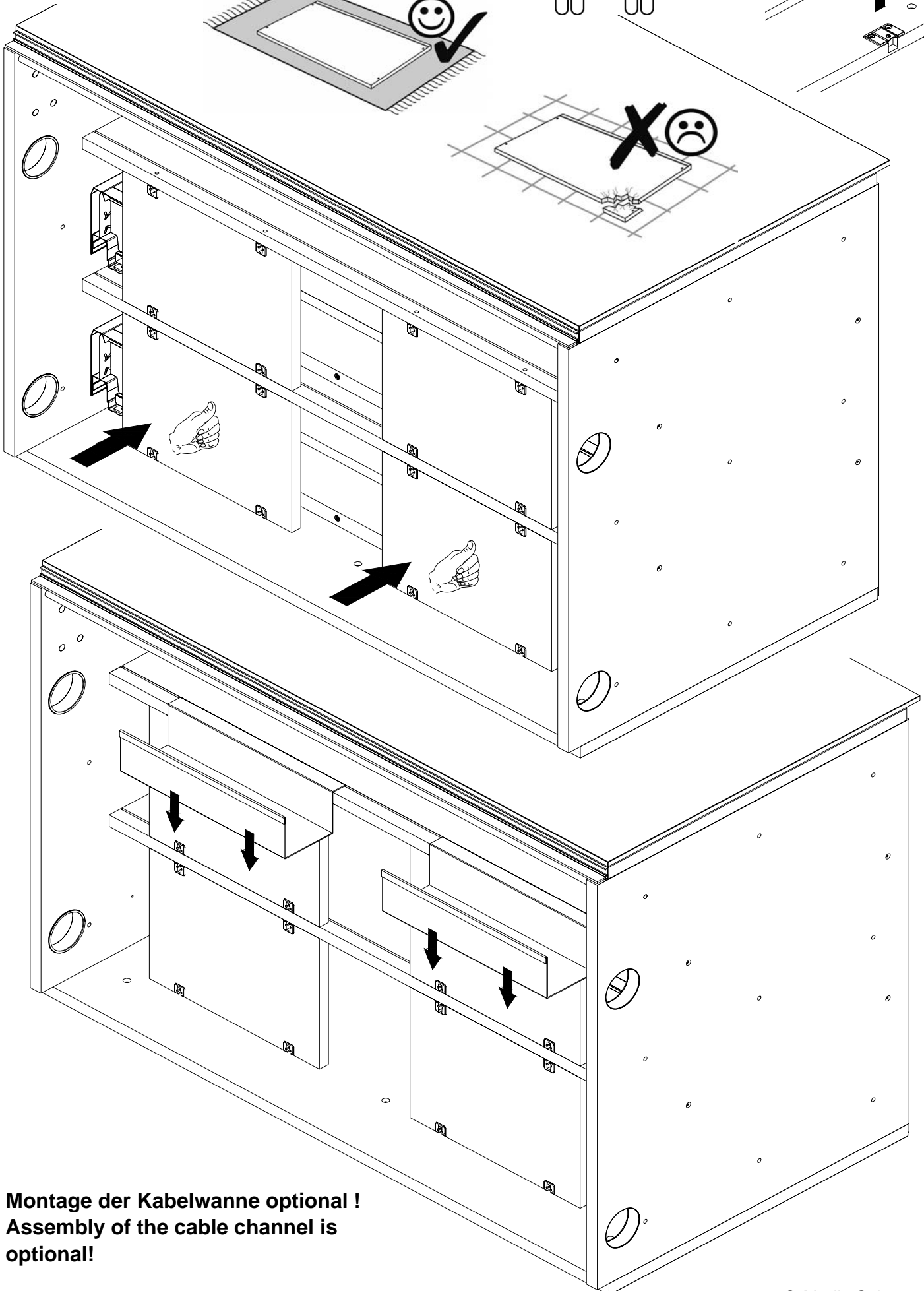
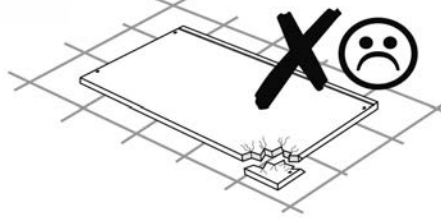
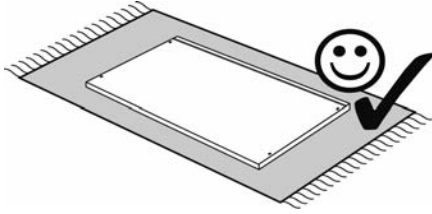
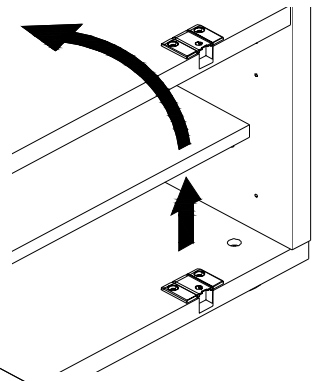
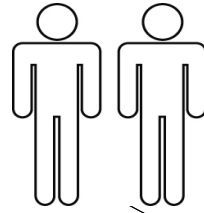

**Montage der Kabelwanne optional !  
Assembly of the cable channel is optional!**



# Q-Media

Anbauelemente 1R  
mit 1 Klappe 20/40/60 cm

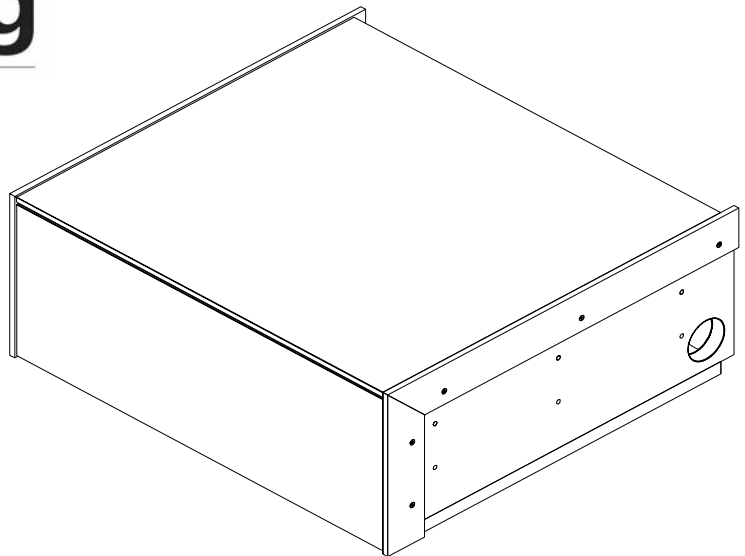

## Beschlagteile Typ 122-144-166

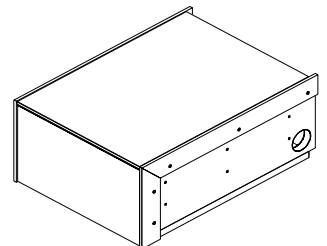
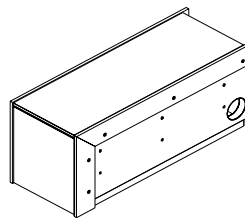
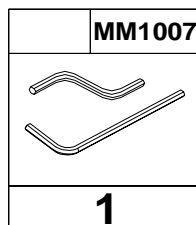
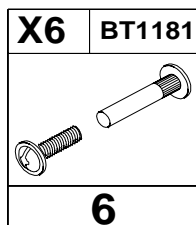
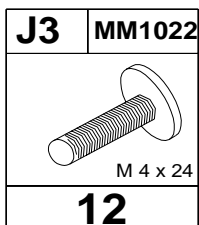

Beschlag / Fitting / Montaža / Felszerelés / Montaj / Vybavení / Vybavenie /  
Ugradnja / Фитинги / Uydurma / Adattamento:

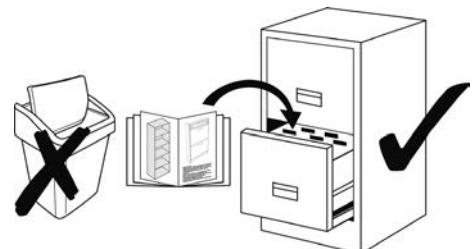
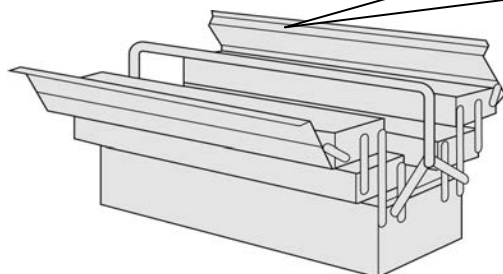
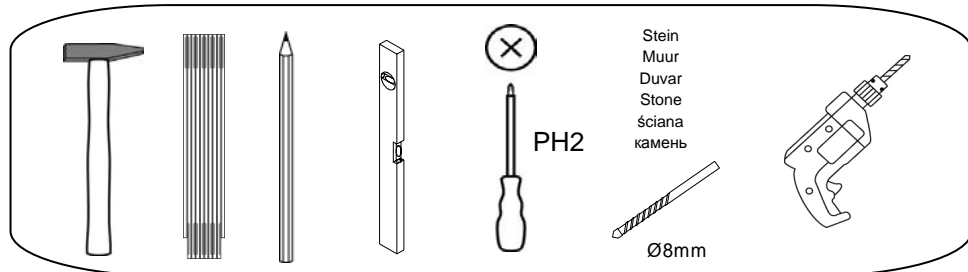
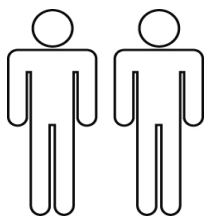

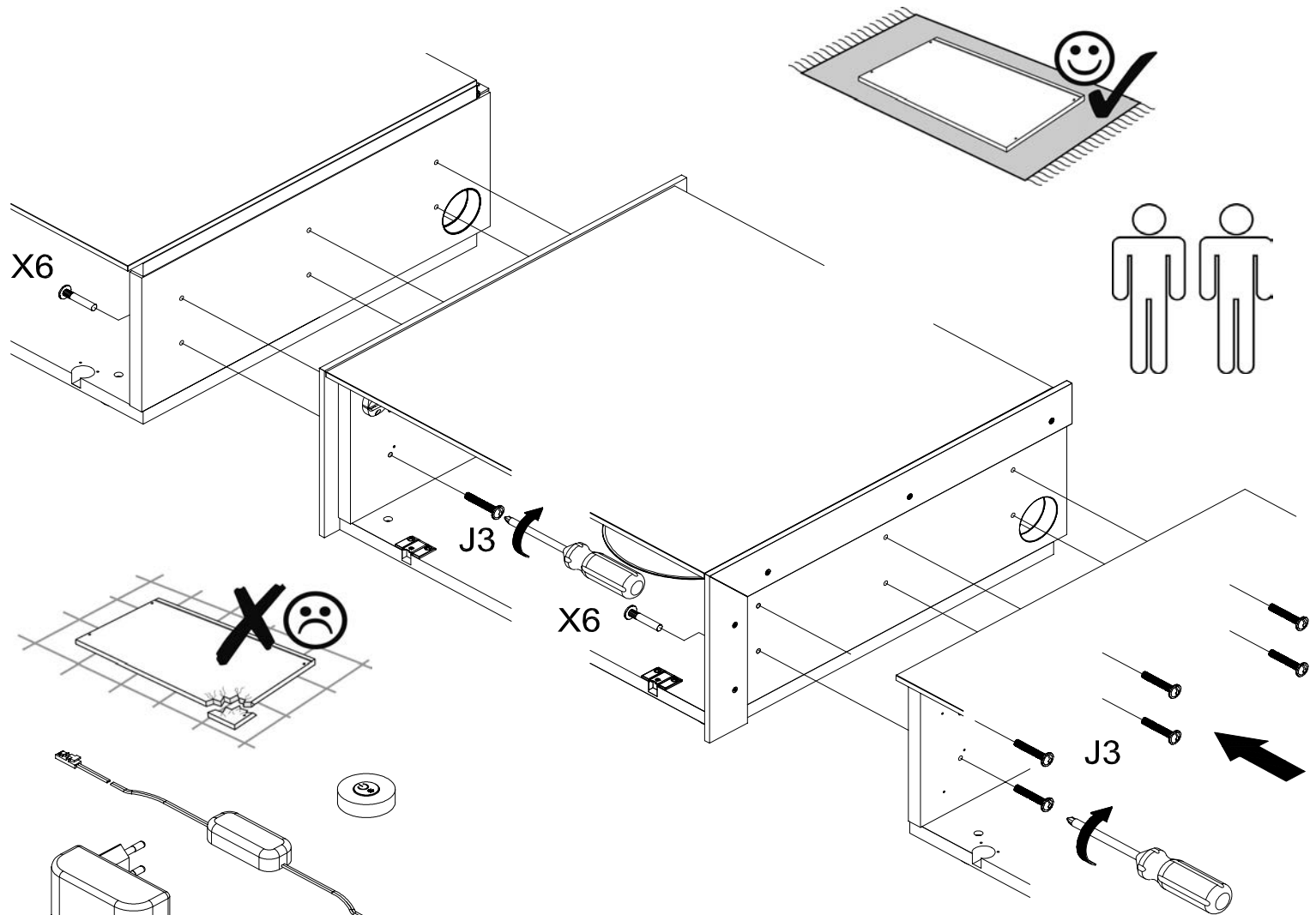

**Beleuchtung optional !**

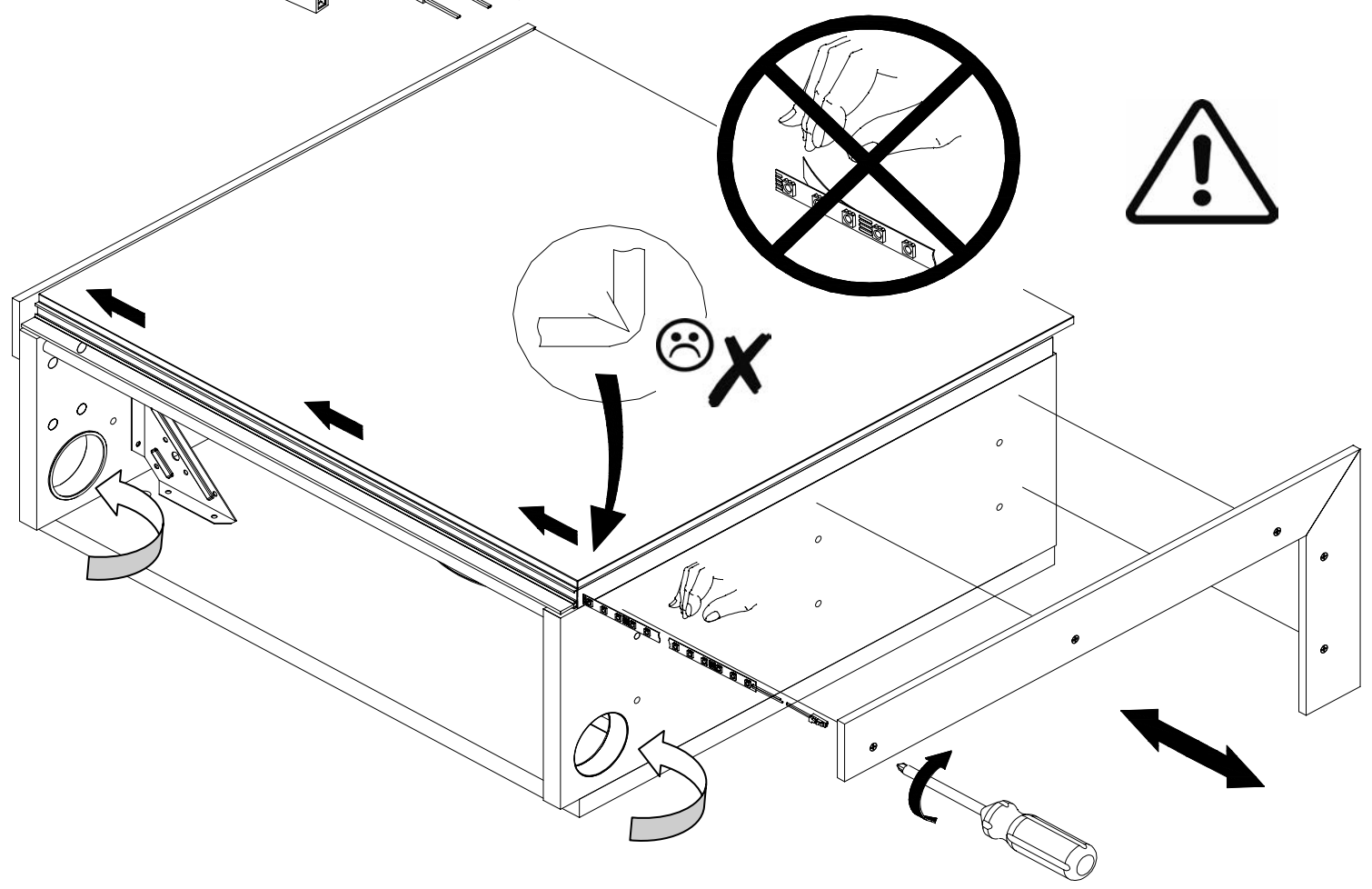

Empfohlene Montagehöhe: 1R = 41,2cm Oberkante Korpus.

2R = 64,8cm Oberkante Korpus.

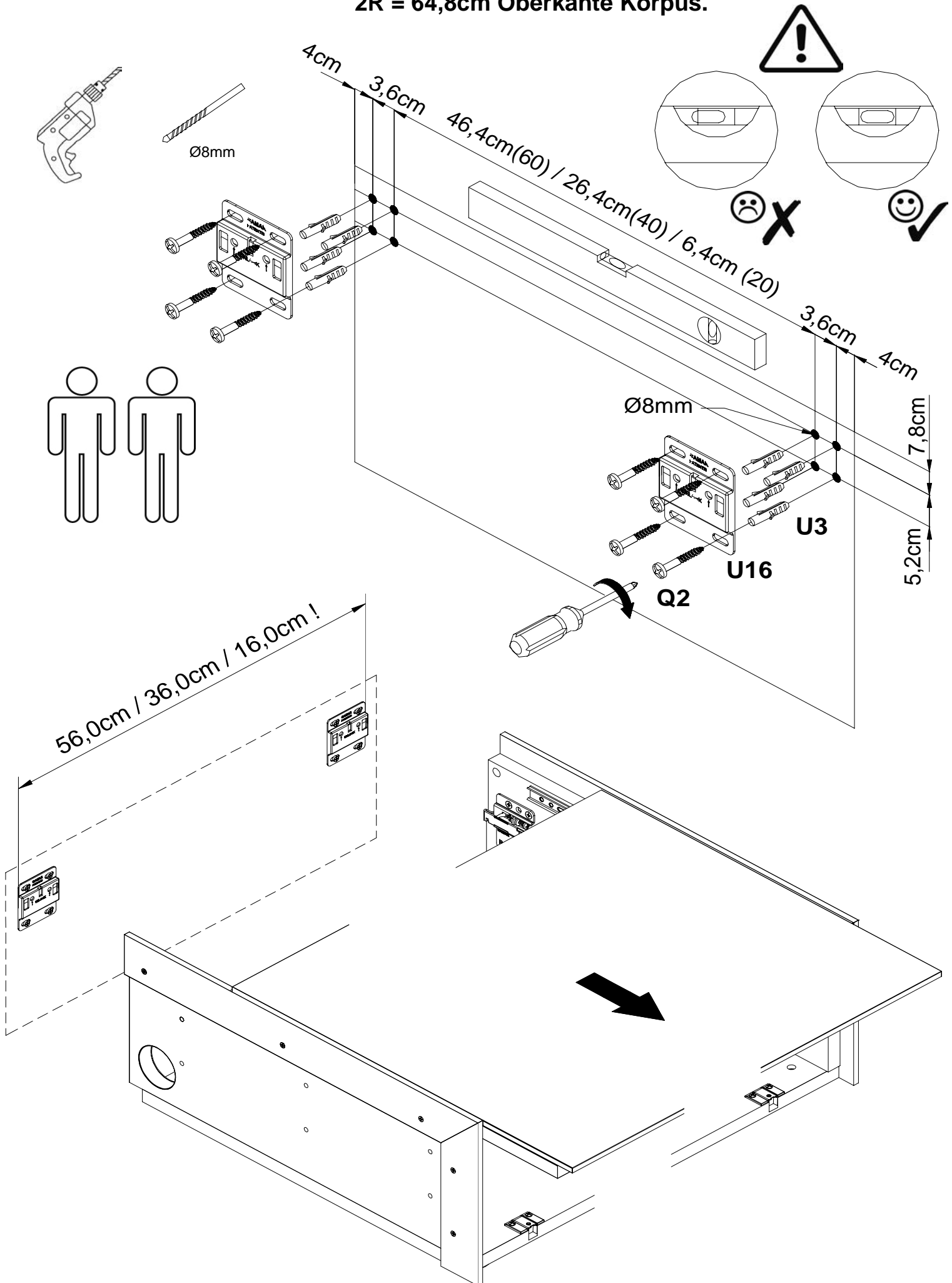

Montage:  
Assembly:

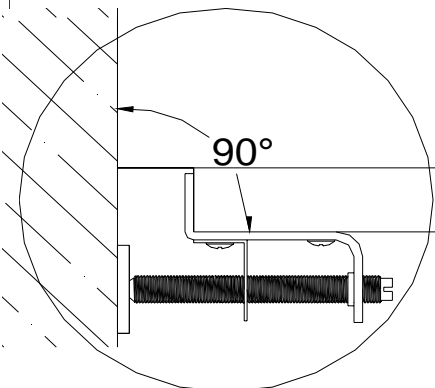
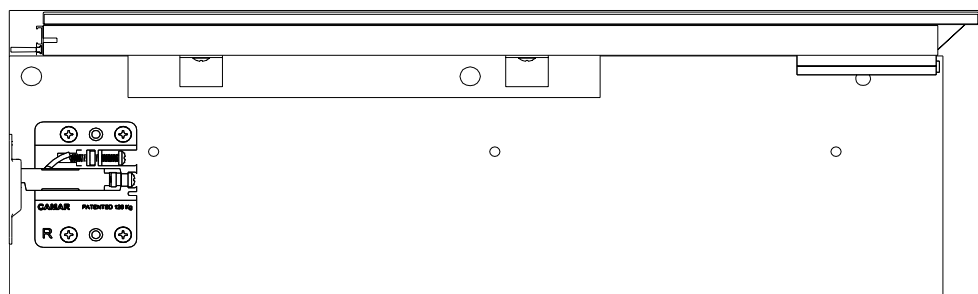
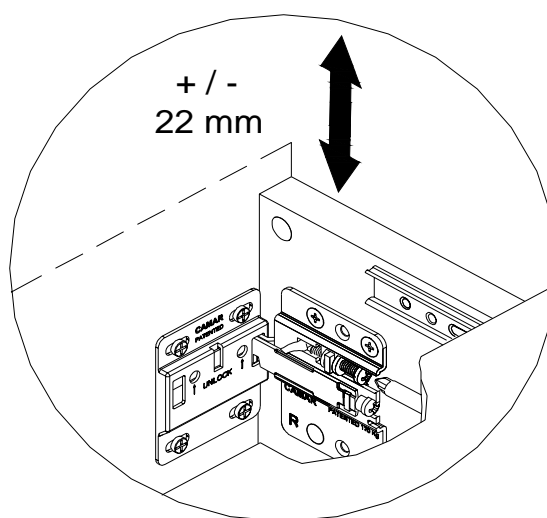
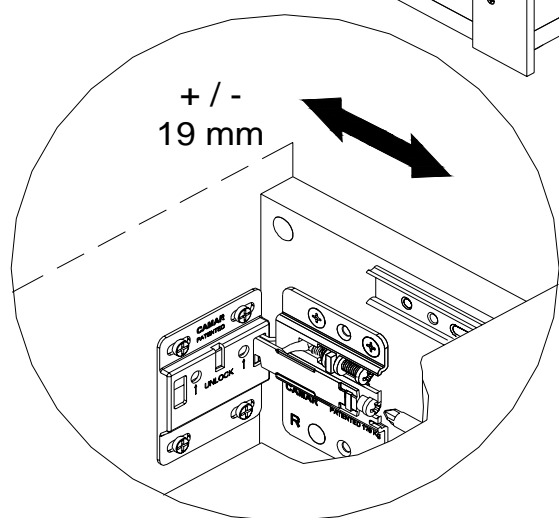
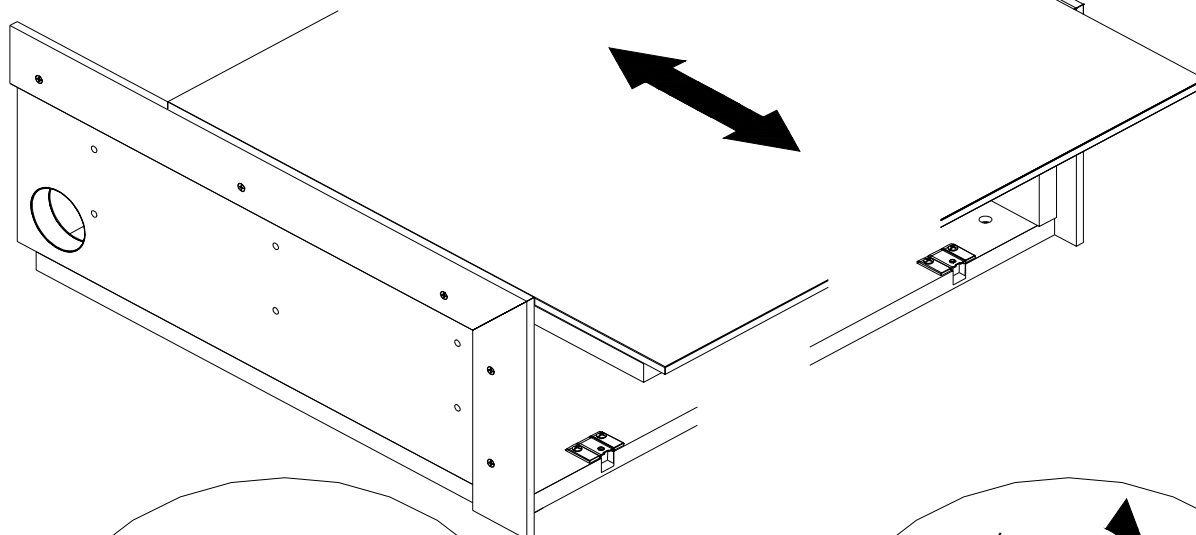
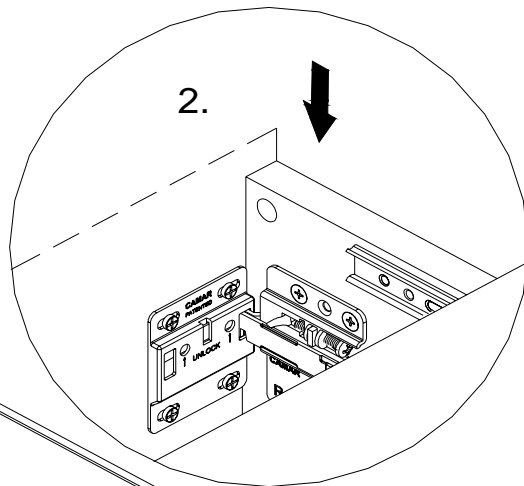
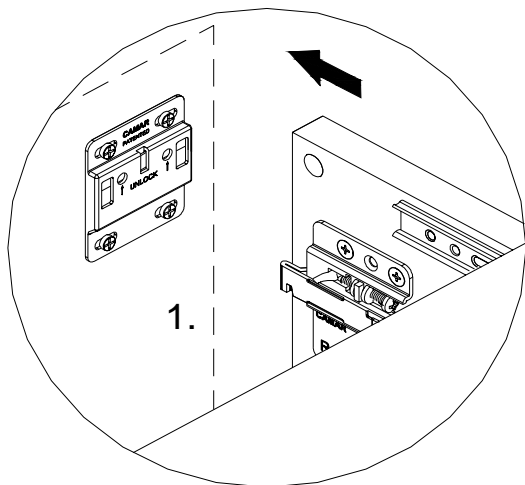

**Ausrichten des Hängeschrankes  
durch die Stellschrauben am  
Aufhängebeschlag:  
Adjustment of the wall cupboard  
with set-screws on the fitting:**

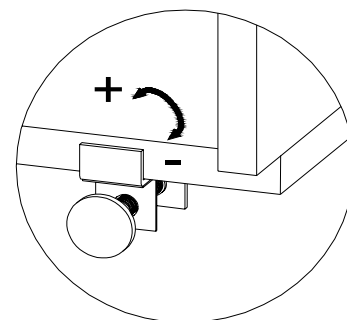

<http://www.youtube.com/watch?v=gwDE9lqXKSs>

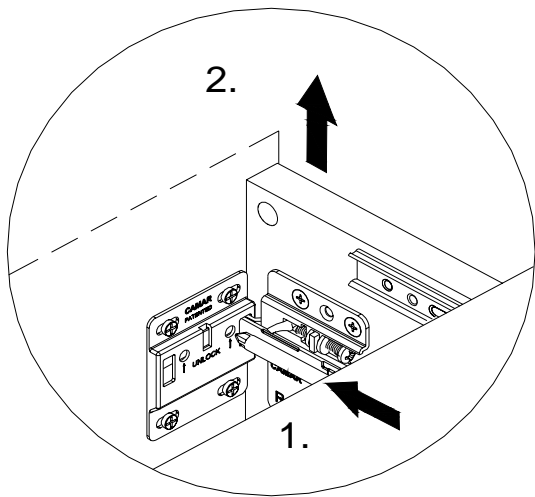

**Demontage:  
Dismounting:**

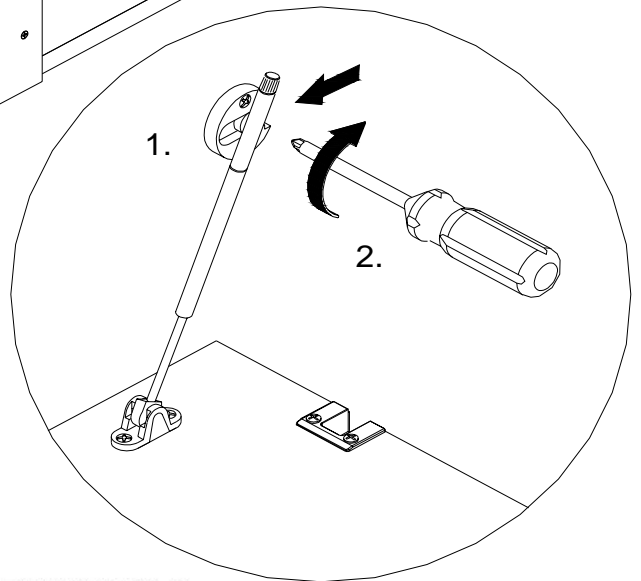
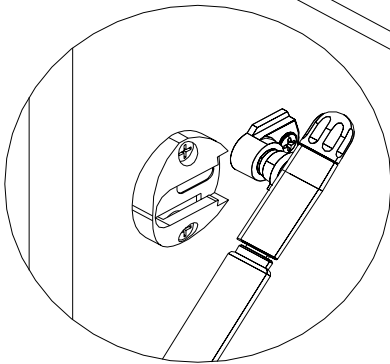
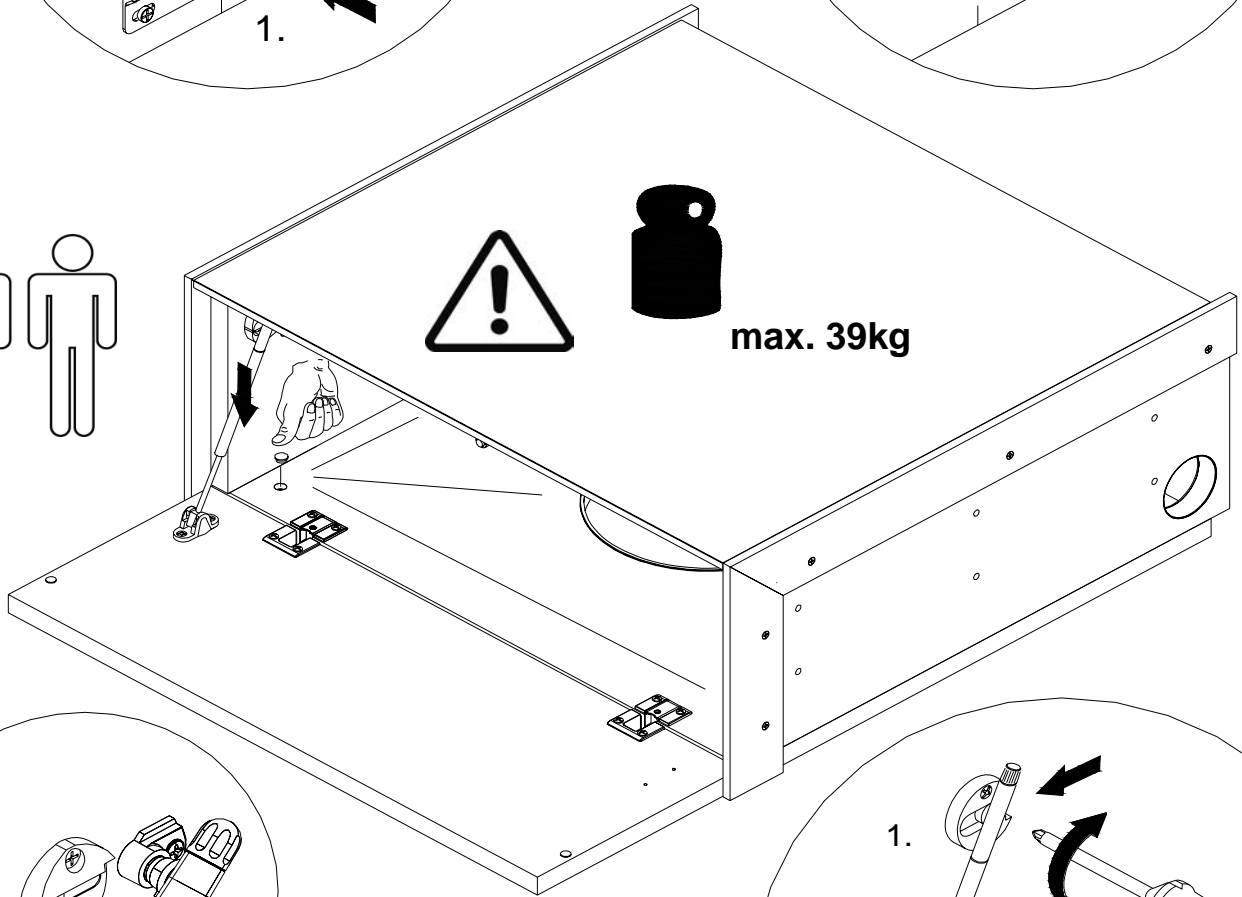
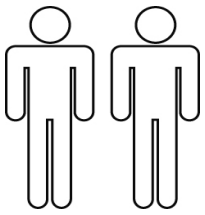
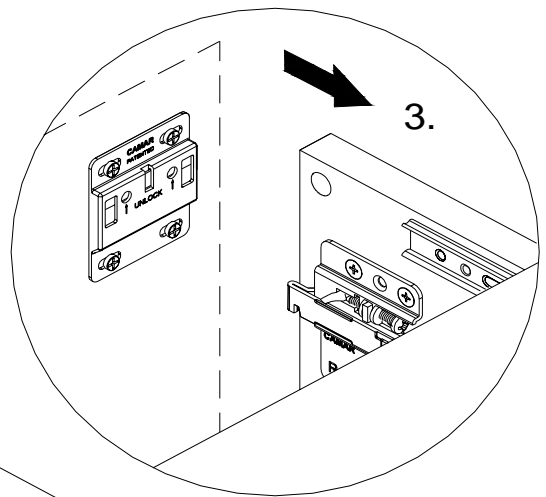

**Montage der Tür siehe Seite 9 !  
Assembly of the door see page 9 !**

**ADJUSTMENTS**

FRONT TO BACK ADJUSTMENT 0 - 10 mm

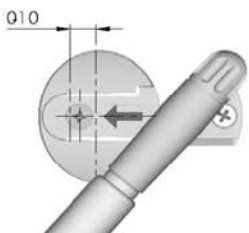

LOCKING

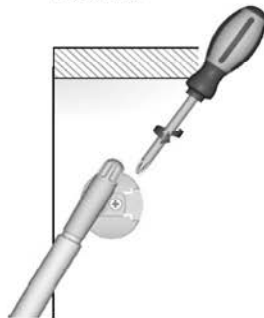

OPEN ANGLE ADJUSTMENT 0 - 10 mm

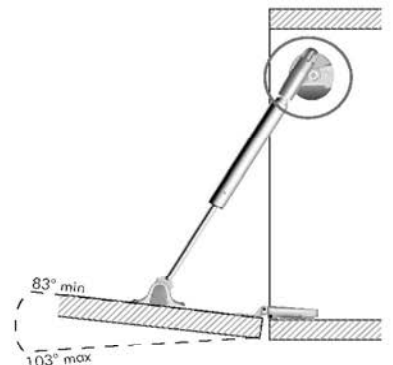
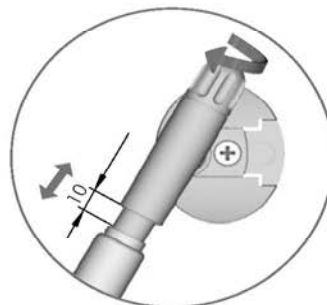

**VERY IMPORTANT**

The side bracket has to be placed with the slot in a horizontal position and the open end facing the wall. The opening of the door can be changed by adjusting the position of the piston base plate within the slot:

- Forwards adjustment = the door opens automatically later.
- Backwards adjustment = the door opens automatically in advance.

# Montage - Tipps zur Installation !

## Assembly tips for the installation!

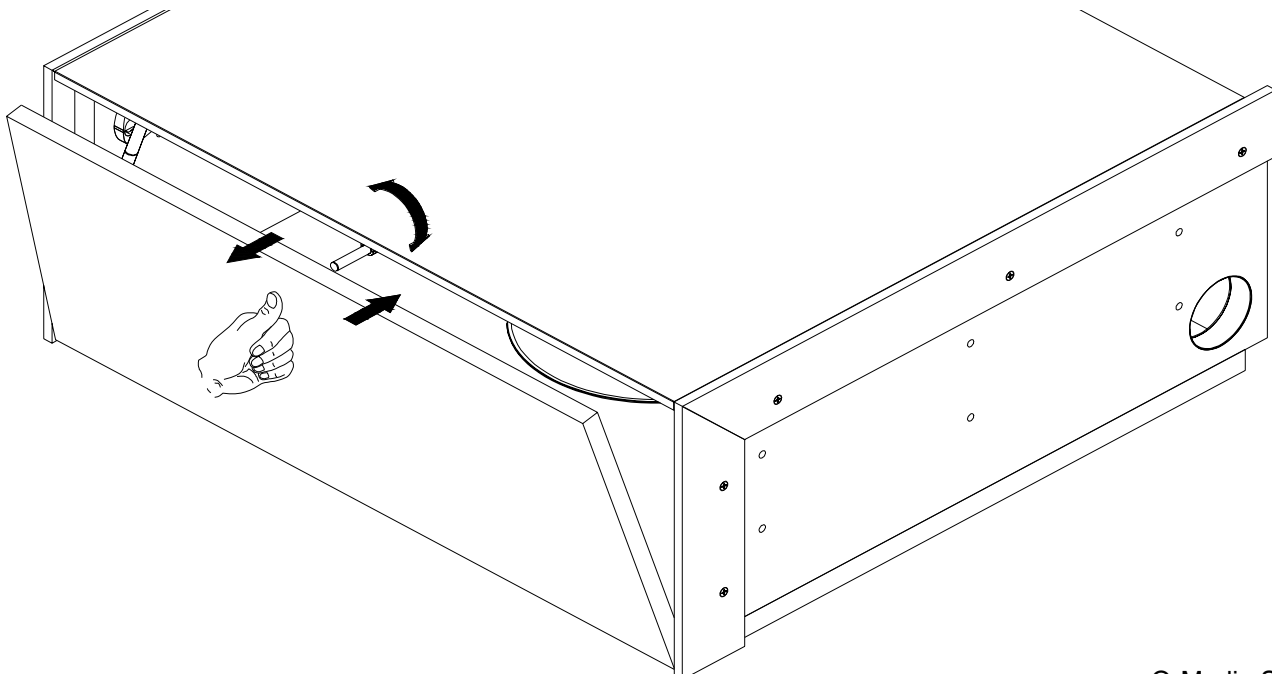
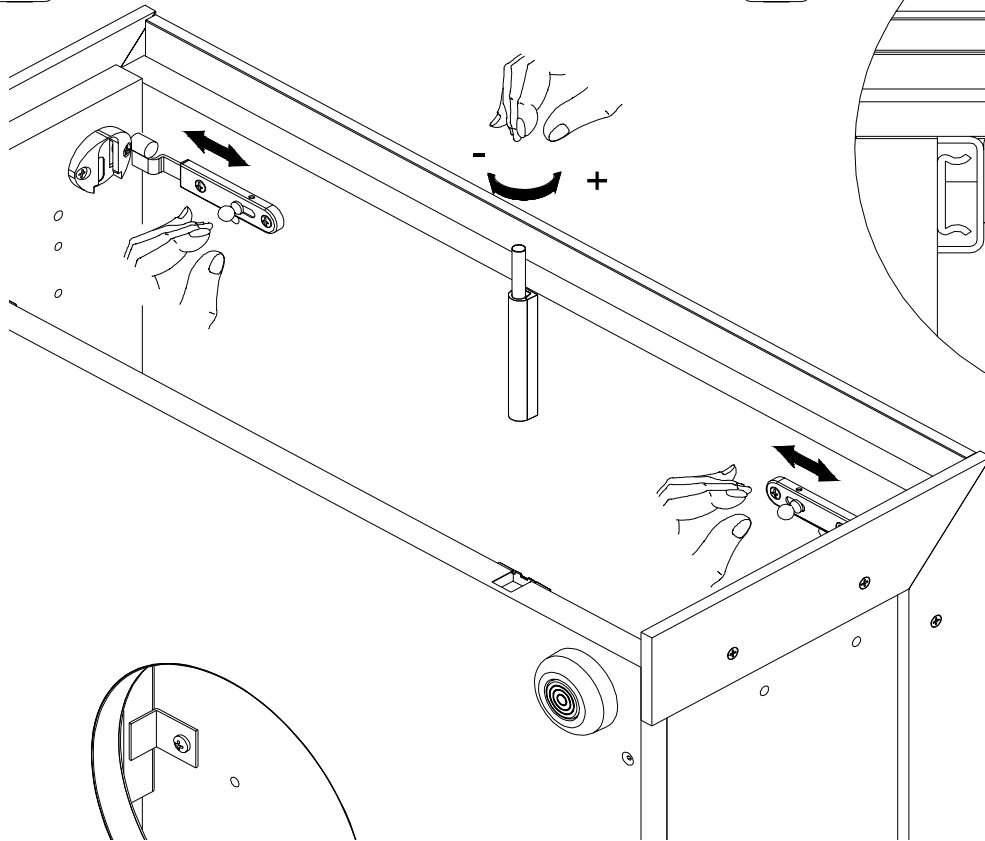
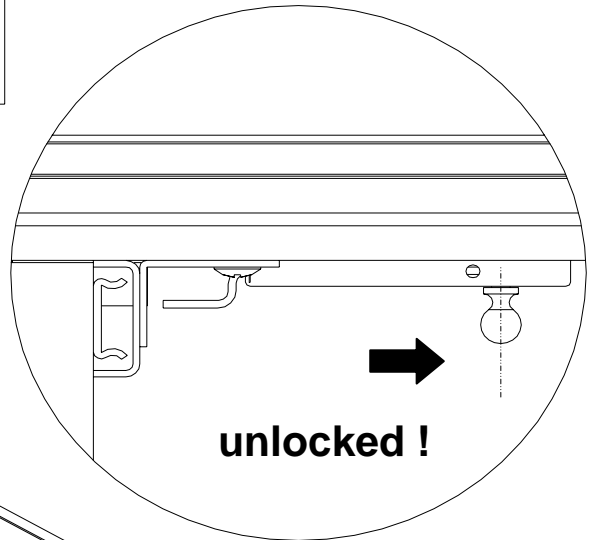
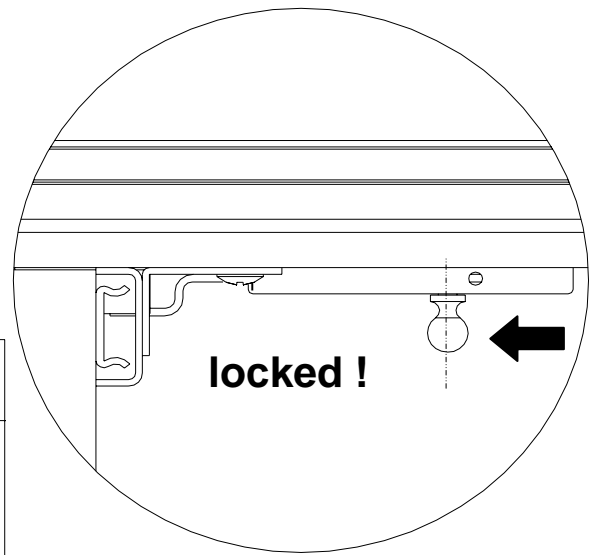
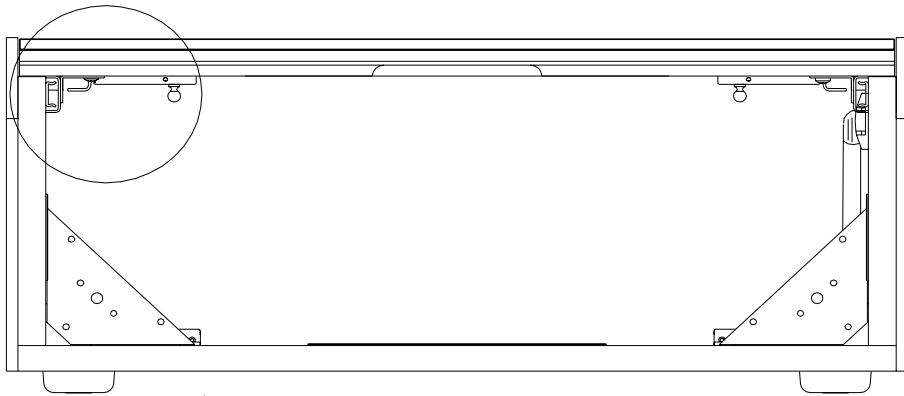

# Q-Media

Anbauelemente 2R  
mit 1 Klappe 20/40/60 cm

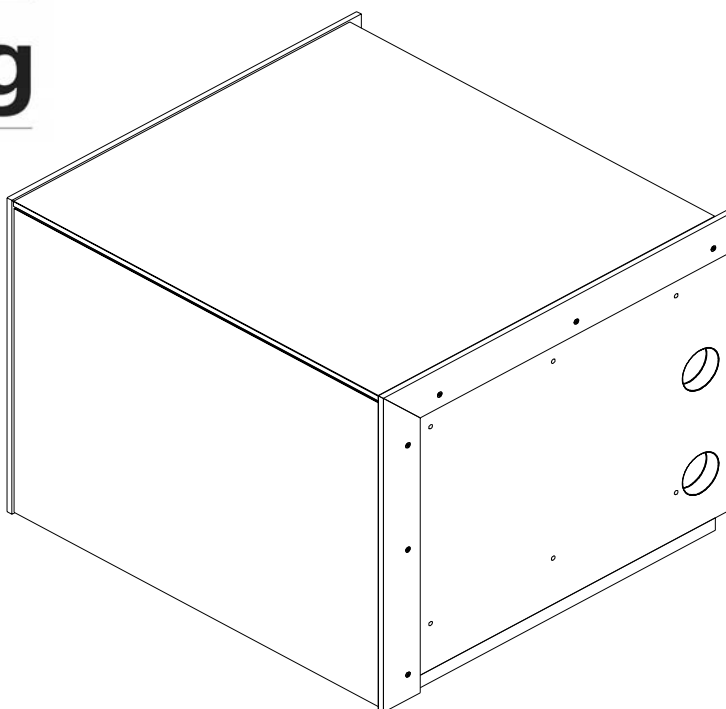

## Beschlagteile Typ 222-244-266

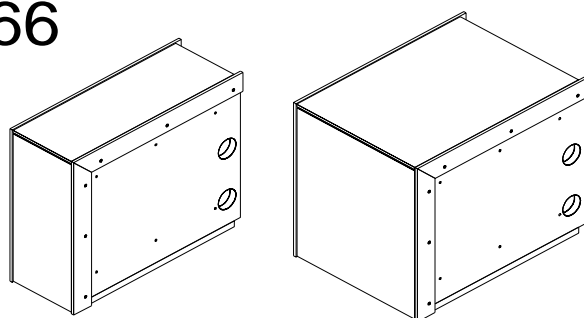
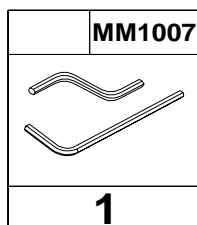
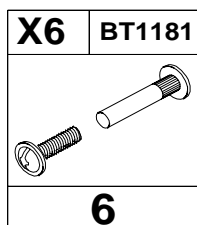
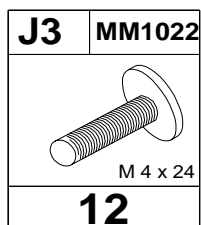

Beschlag / Fitting / Montaža / Felszerelés / Montaj / Vybavení / Vybavenie /  
Ugradnja / Фитинги / Uydurma / Adattamento:

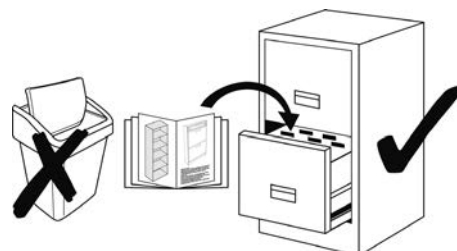
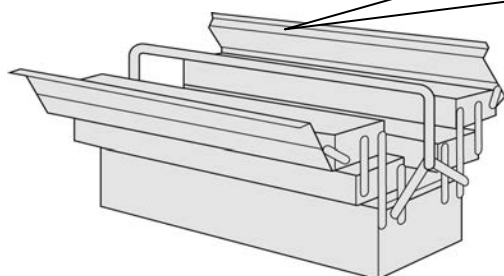
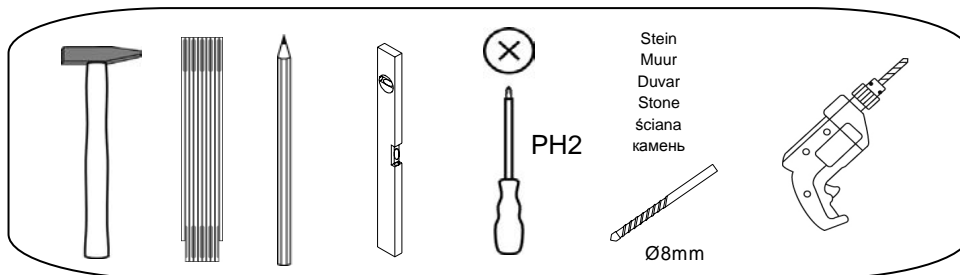
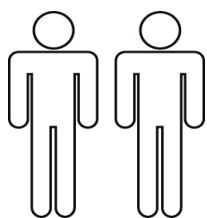

**Montage - Tipps  
zur Installation !**

**Assembly tips  
for the installation!**

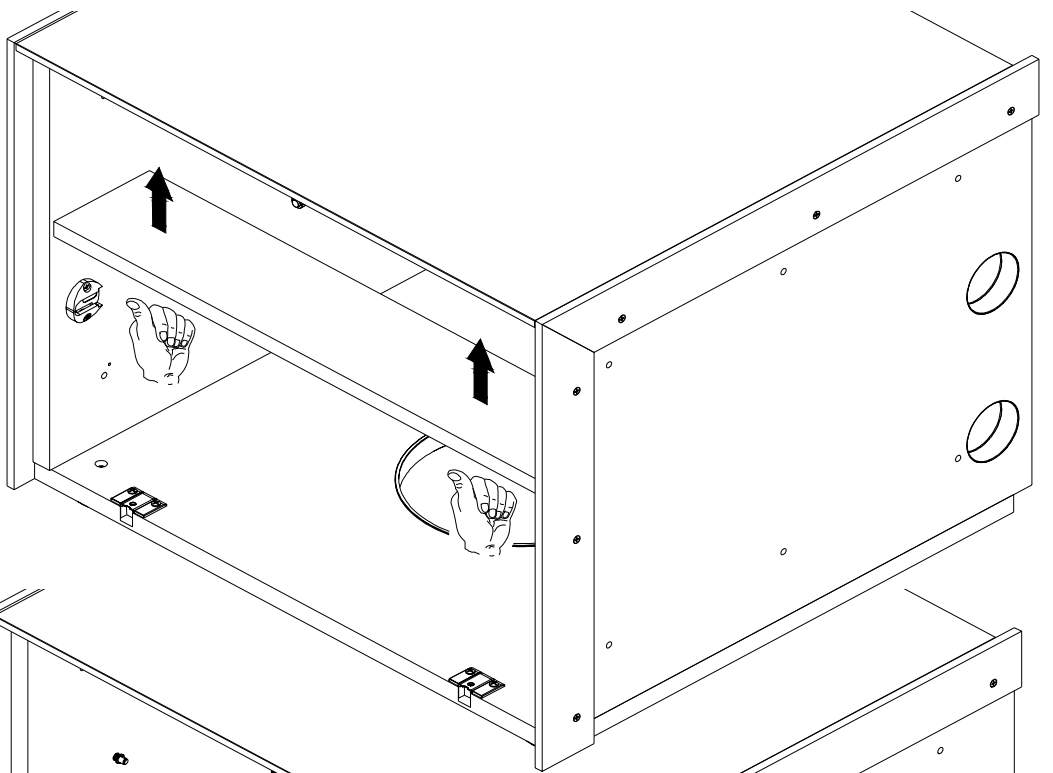
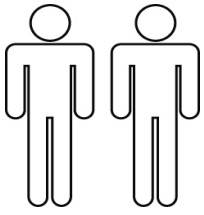

**Montage der Hifi-Anlage  
ist optional !**

**Assembly of the Hifi-  
part is optional !**

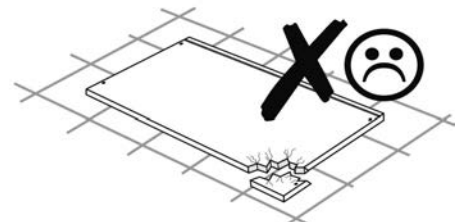
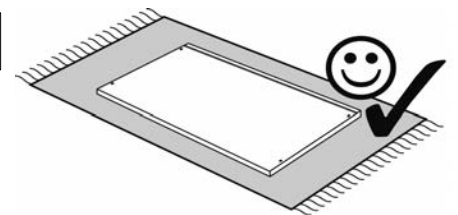
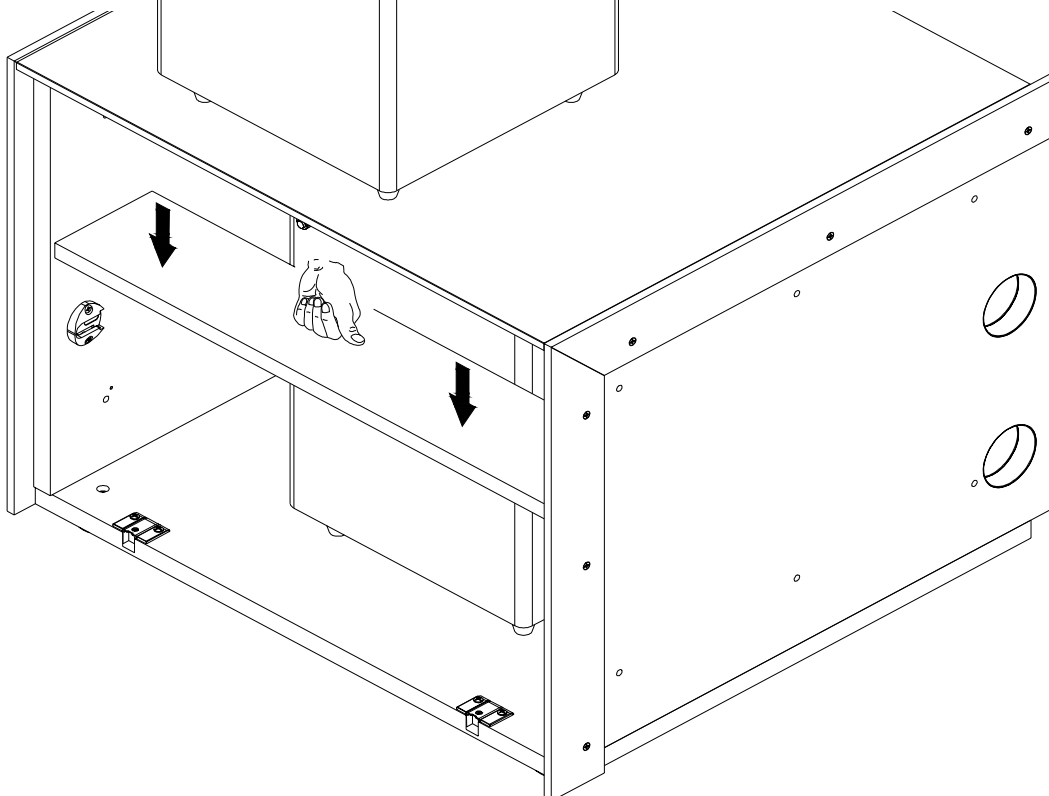
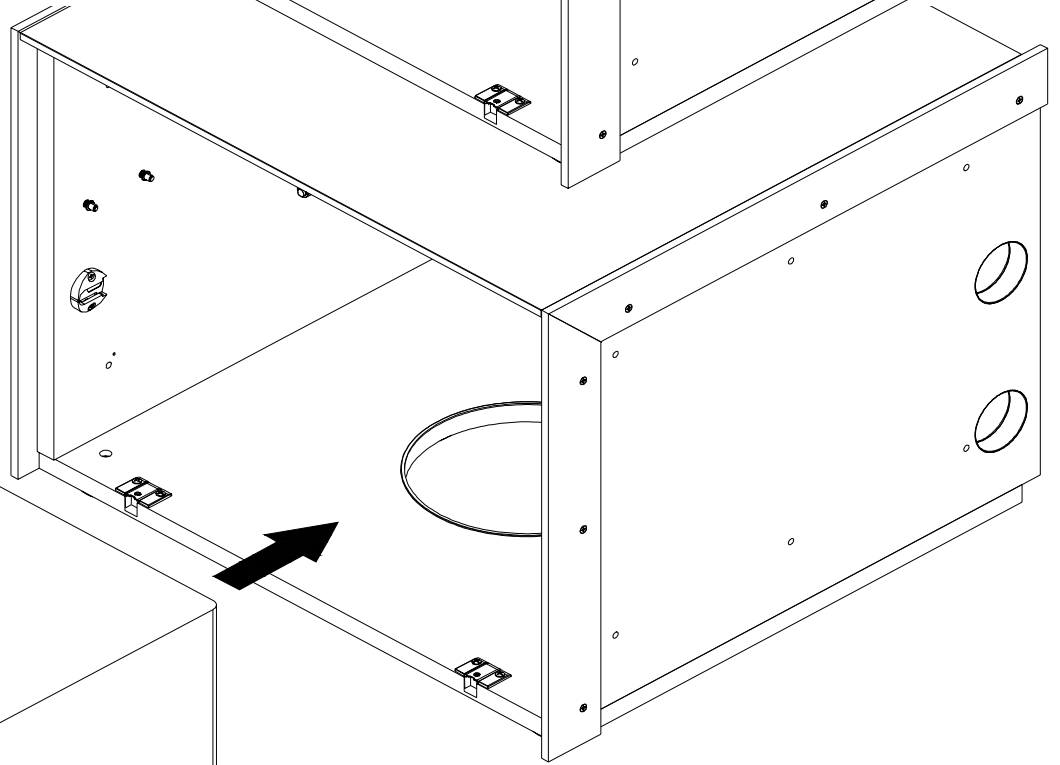



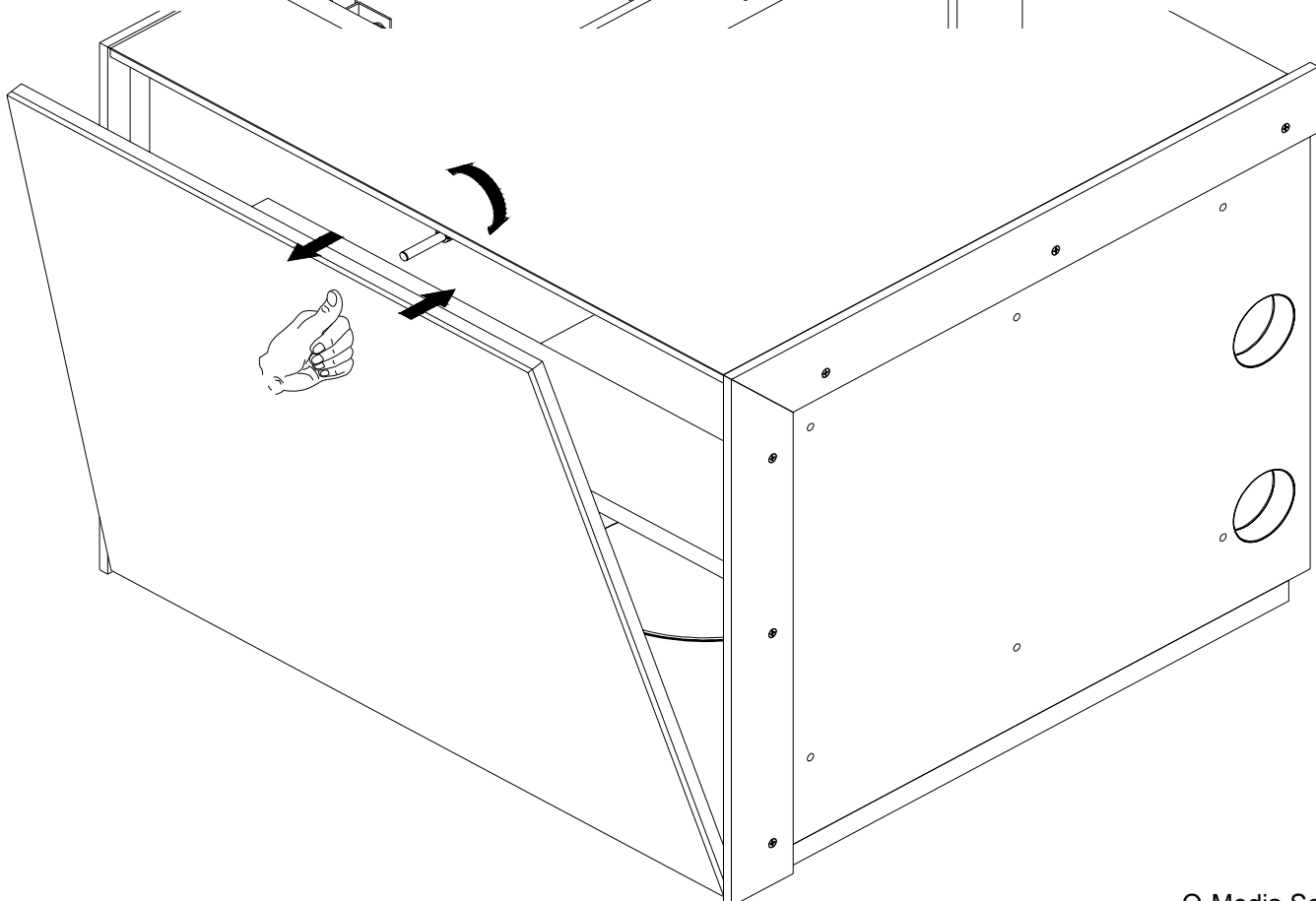
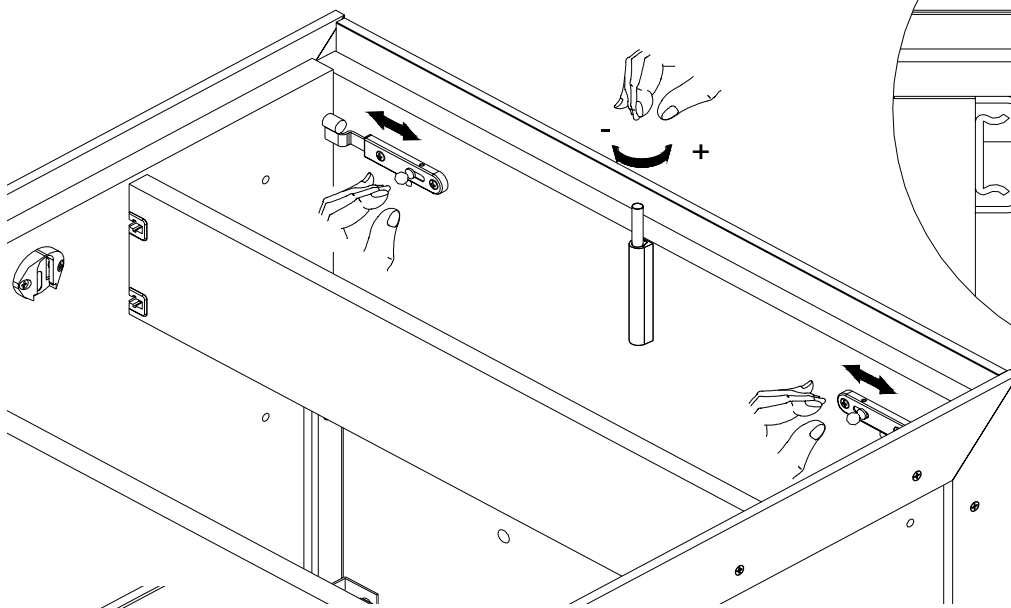
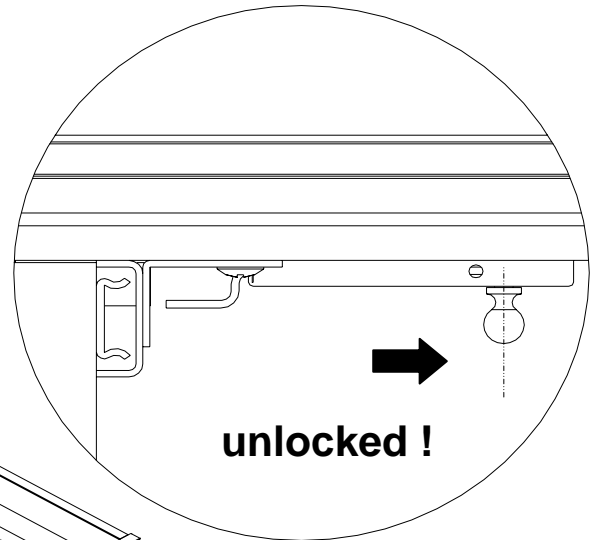
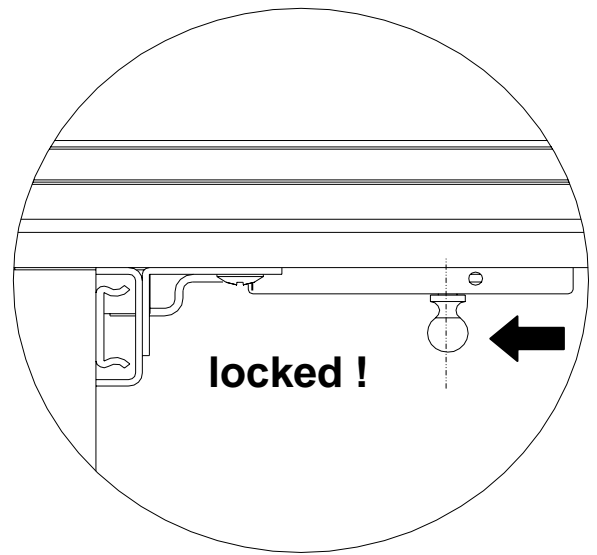
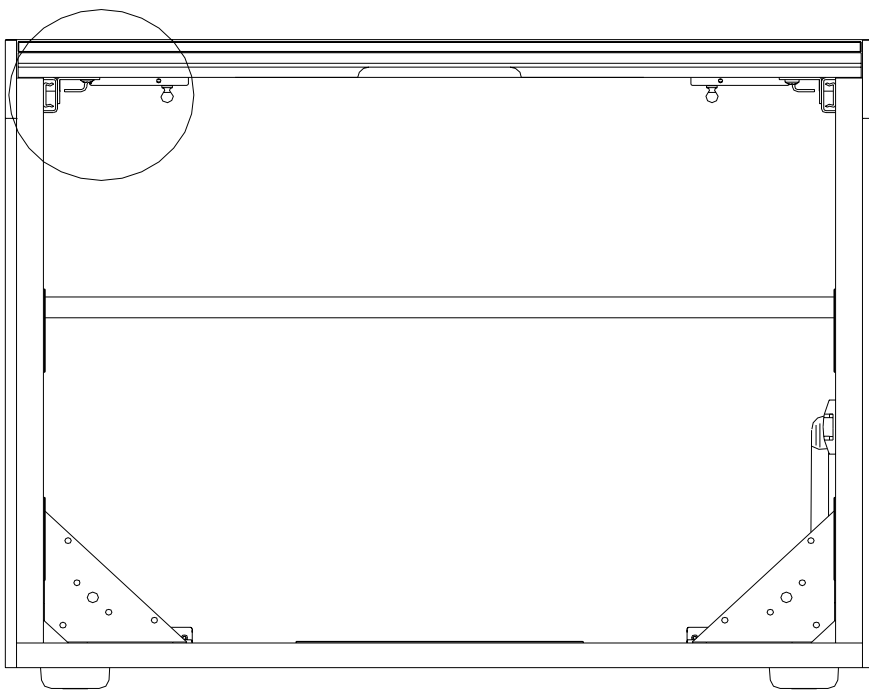

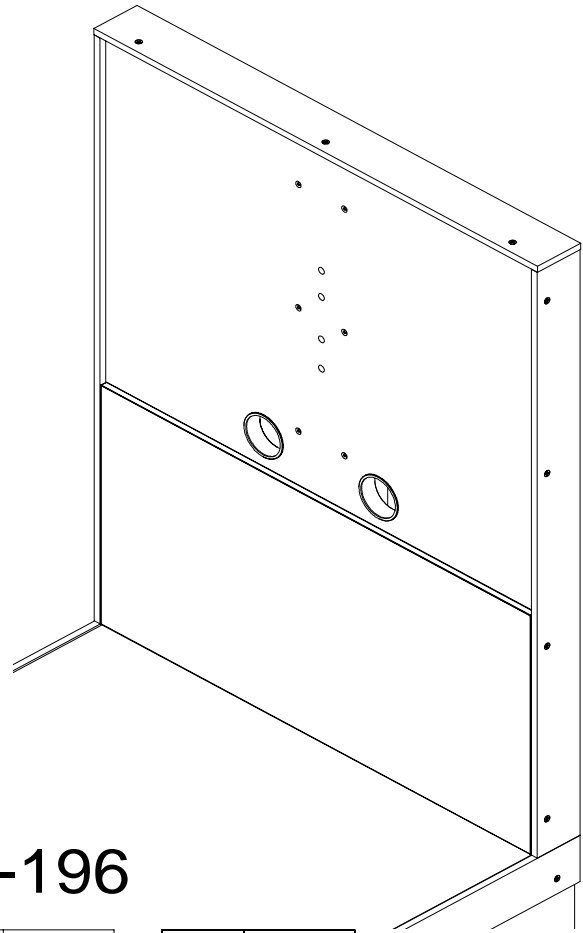

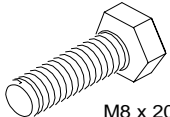
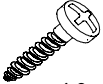

### Beschlagteile Typ 192-194-196

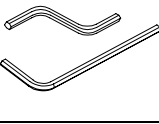
<b>J22</b>   <b>BT1415</b>	<b>J23</b>   <b>BT1410</b>	<b>Q4</b>   <b>MM1014</b>	<b>X31</b>   <b>MM1140</b>	<b>MM1007</b>
				
M6 x 10	M8 x 20	4,0 x 17	M8	
<b>4</b>	<b>8</b>	<b>4</b>	<b>8</b>	<b>1</b>

Beschlag / Fitting / Montaža / Felszerelés / Montaj / Vybavení / Vybavenie /  
Ugradnja / Фитинги / Uydurma / Adattamento:

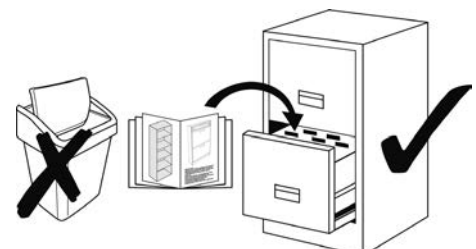
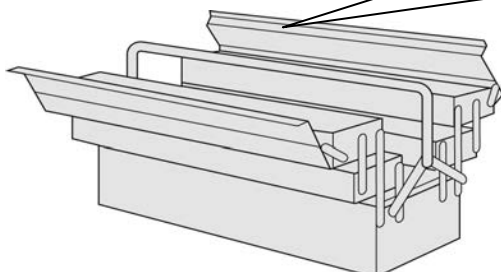
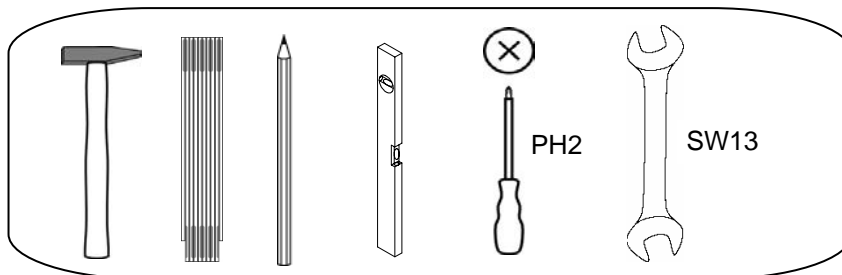
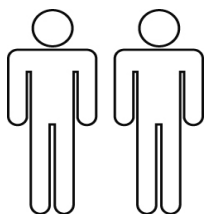

# Type 196

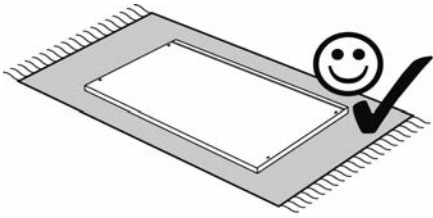

19616-

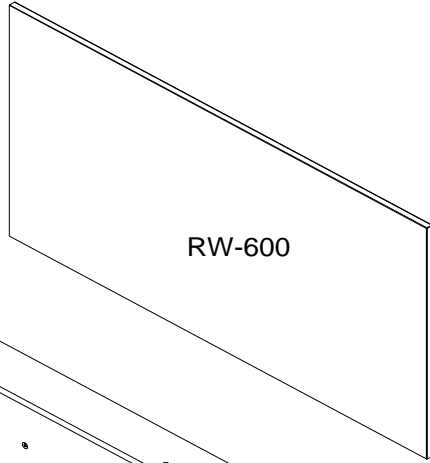

RW-600

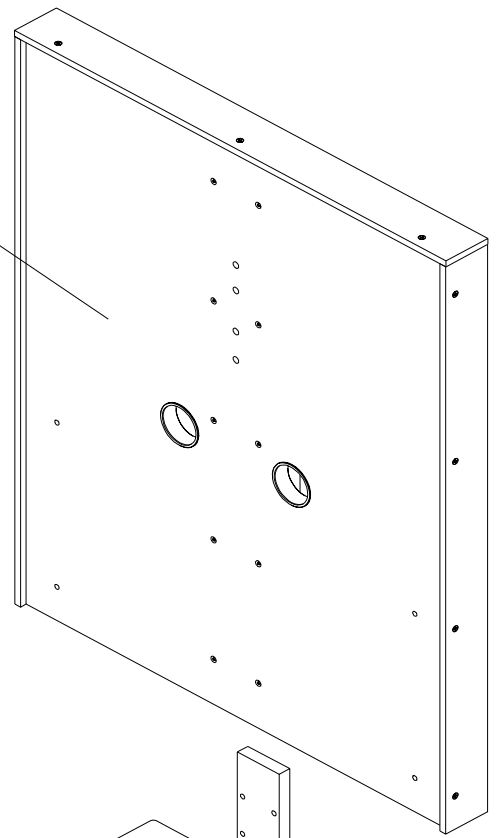

# Type 194

19416-

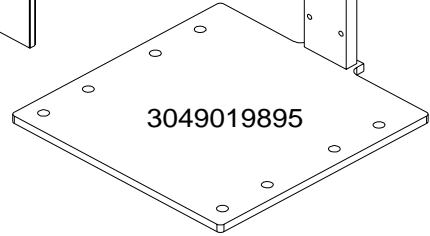
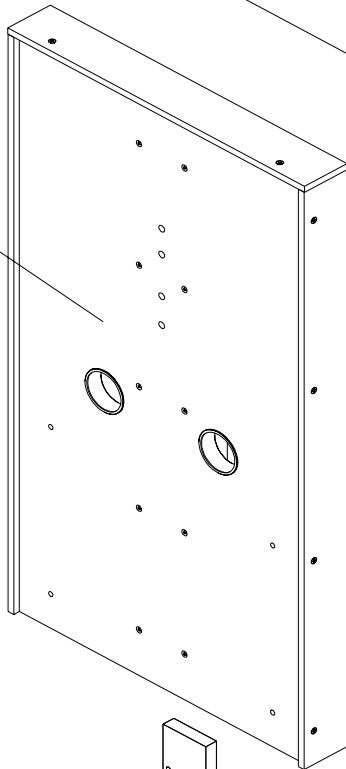

3049019895

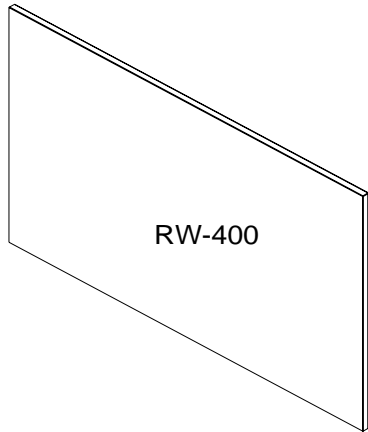

RW-400

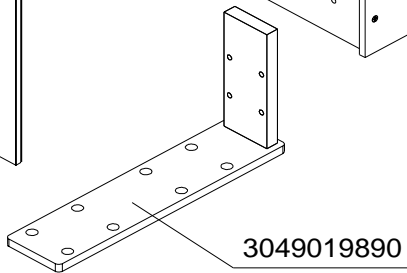

3049019890

19216-

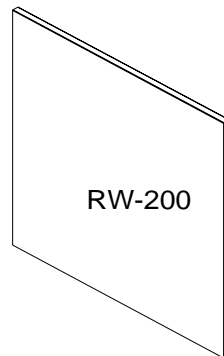
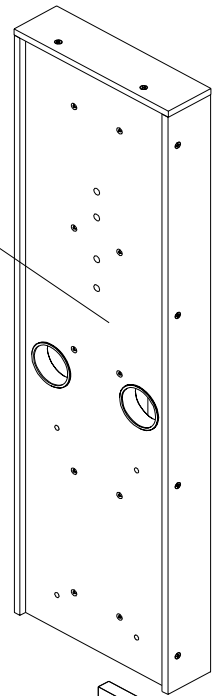

RW-200

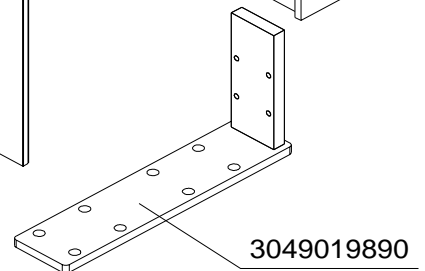

3049019890

# Type 192

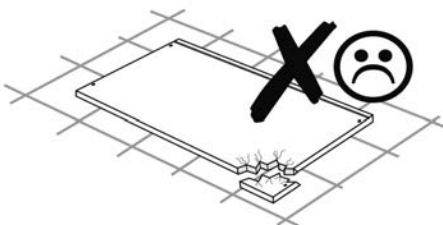

1.

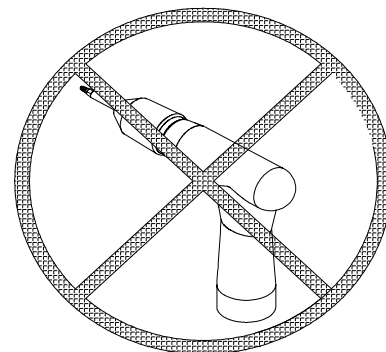
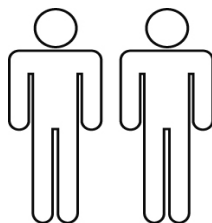
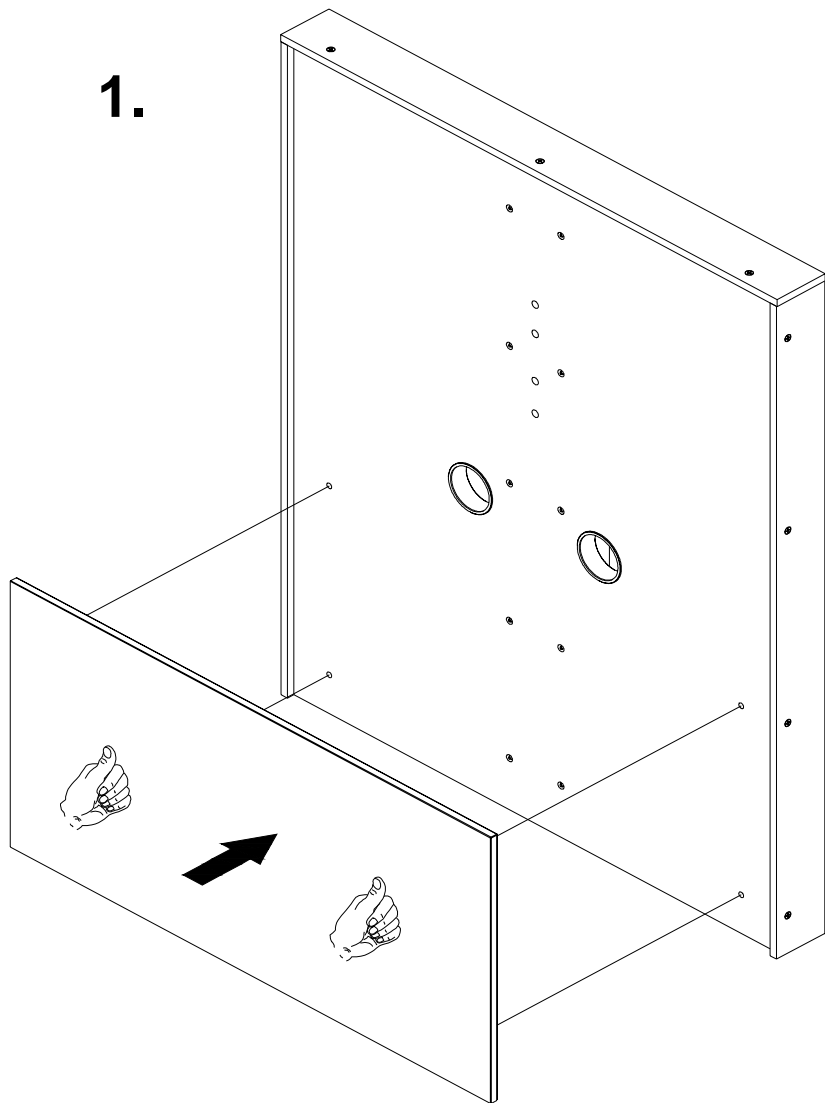

2.

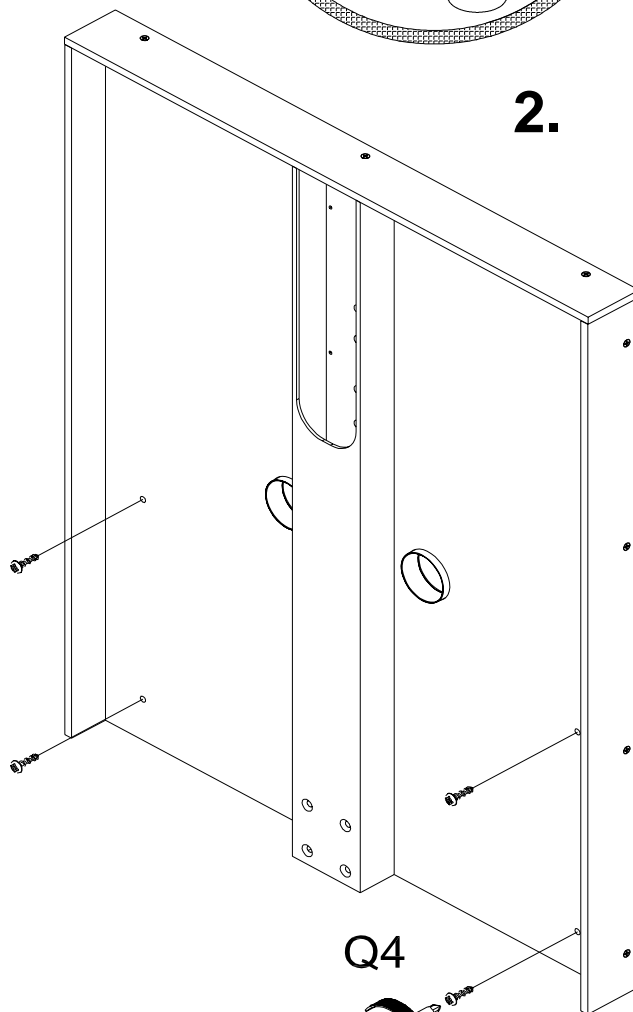

3.

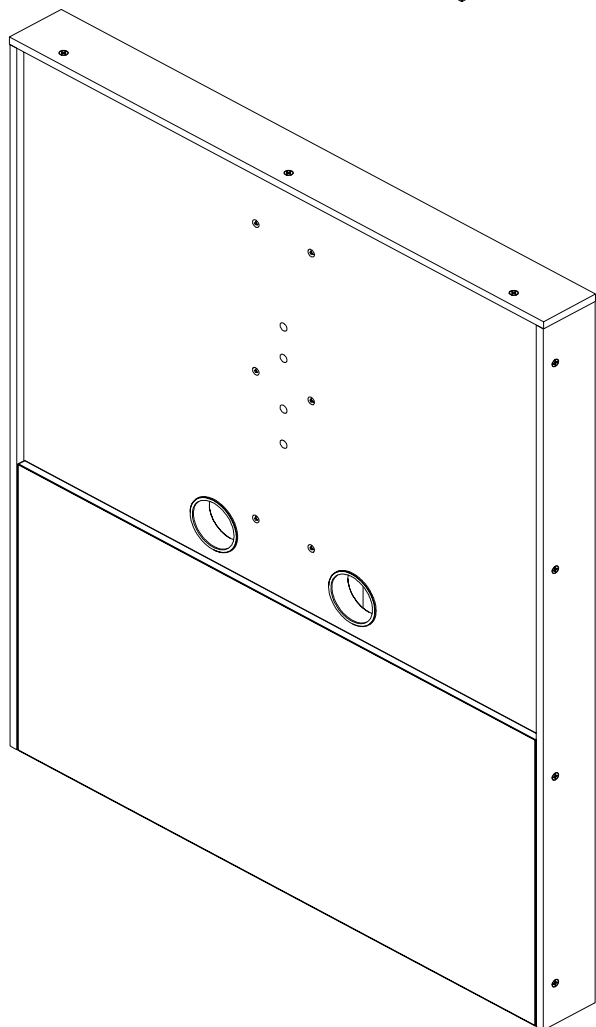

Q4

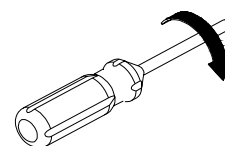

**Die Schrauben zur Befestigung der Rückwand nur mit einem Handschraubendreher anziehen. Keinen Elektro- oder Akkuschauber verwenden.**

**Only use a hand screwdriver to attach the screws . Do not use an electric or cordless screwdriver.**

4.

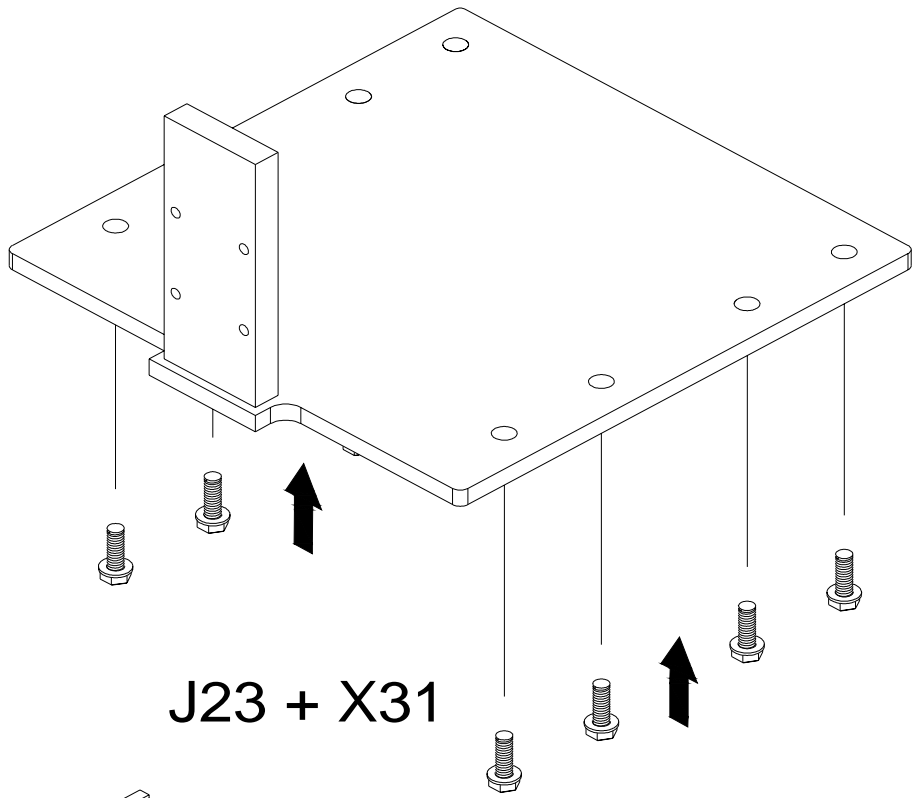
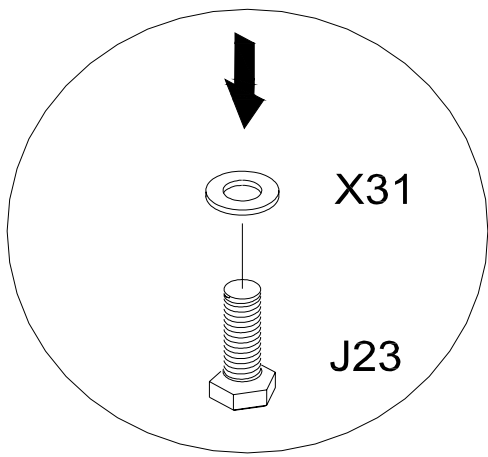

5.

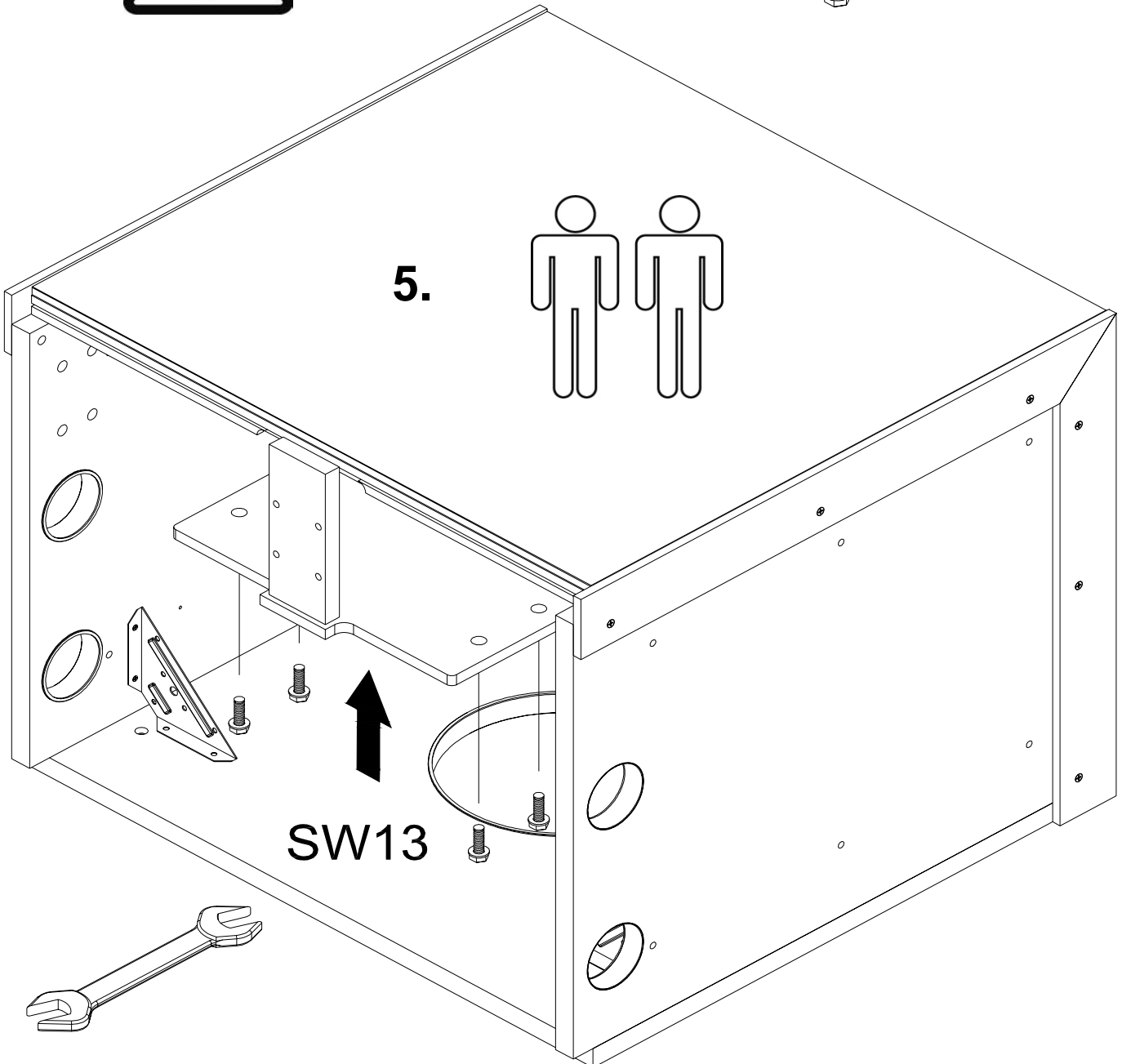
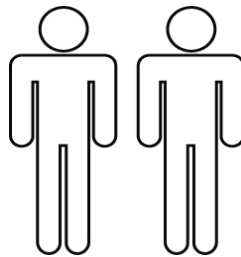

6.

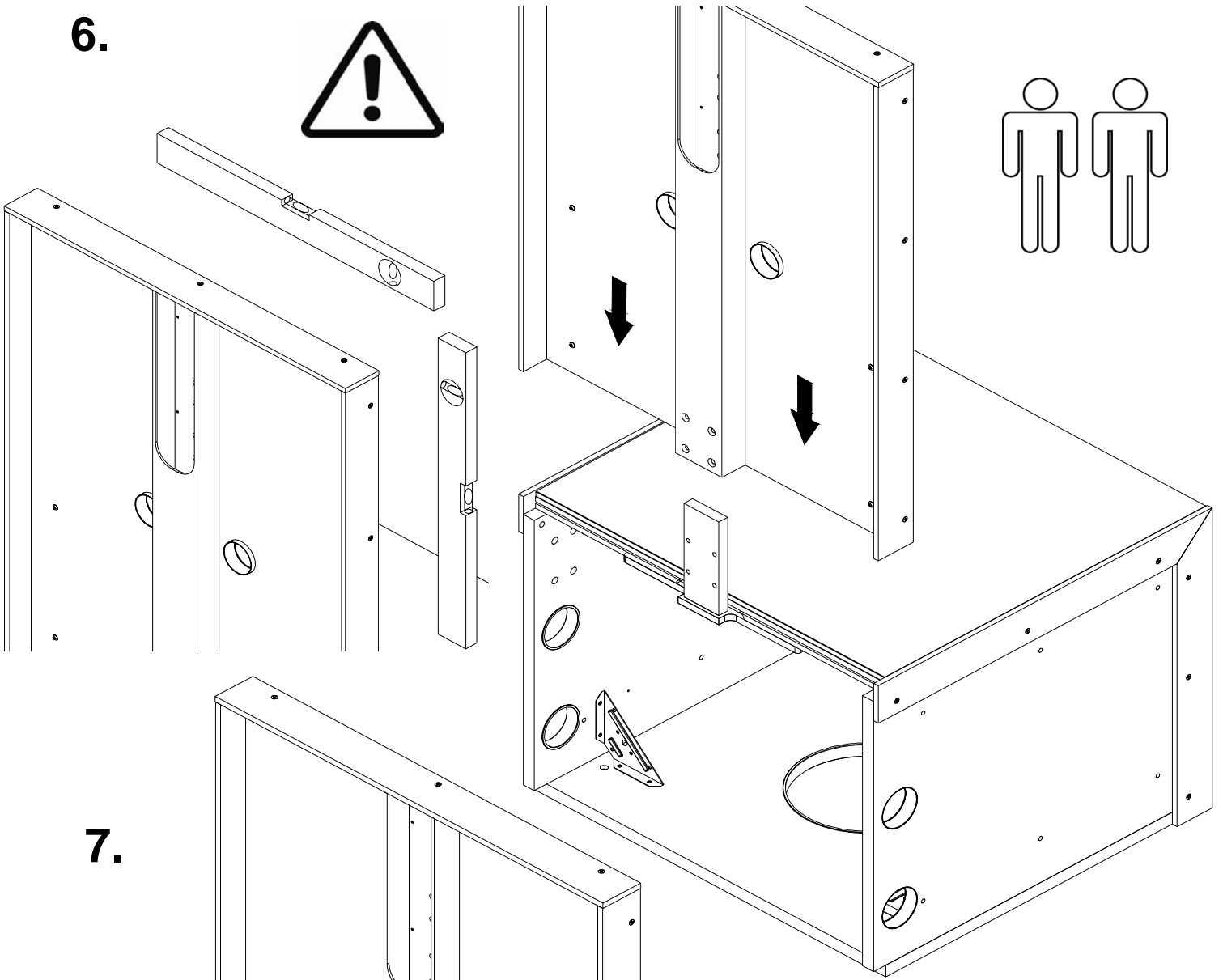
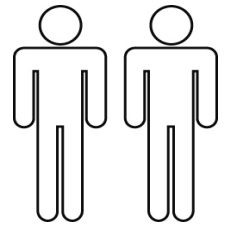

7.

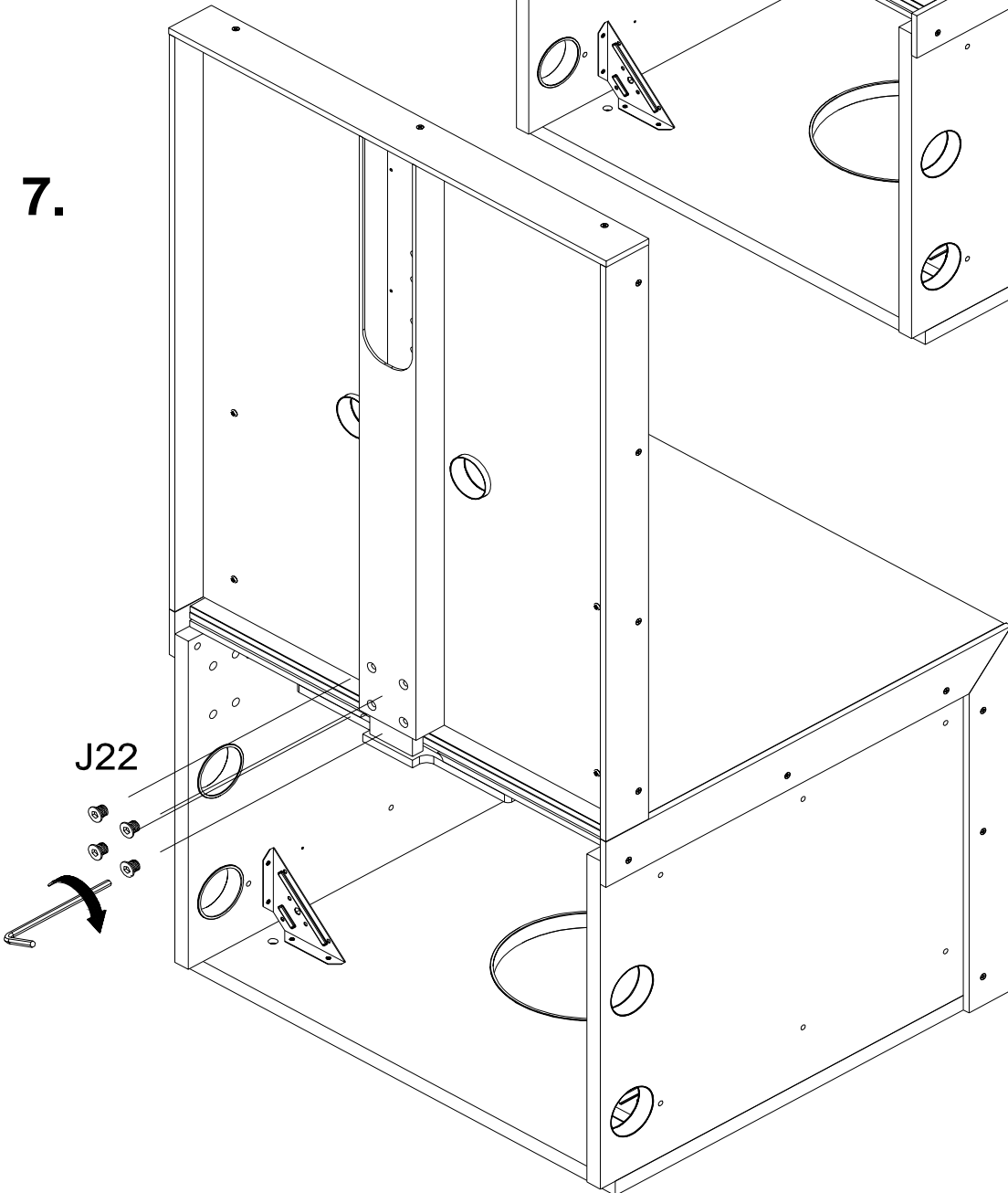

8.

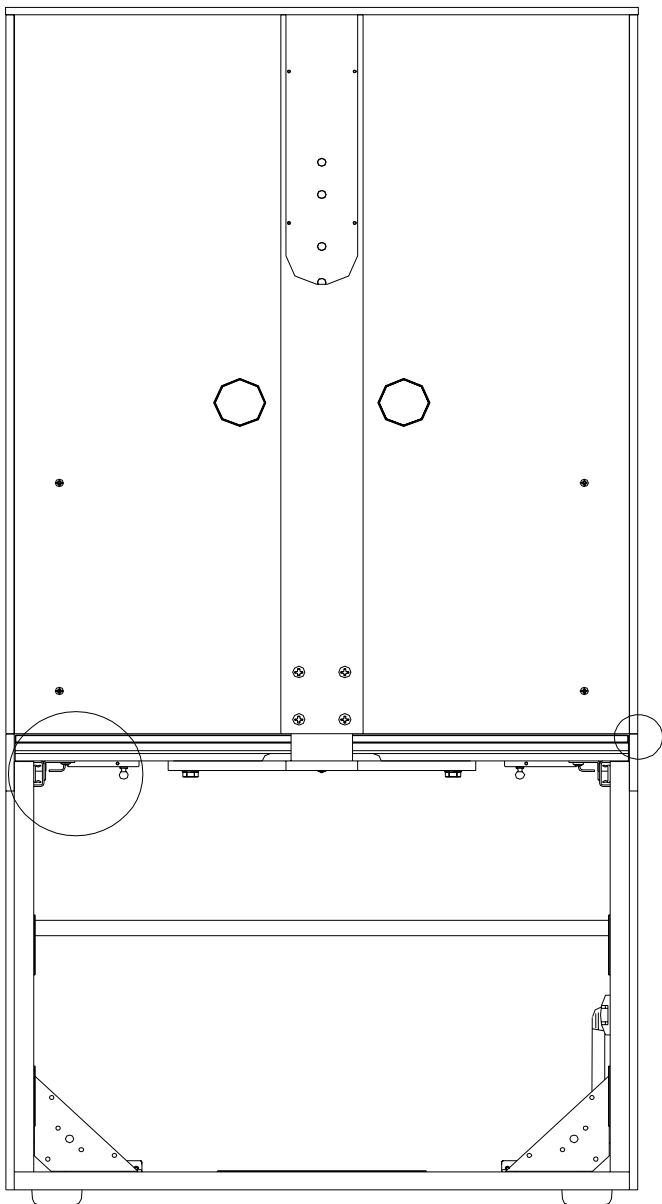
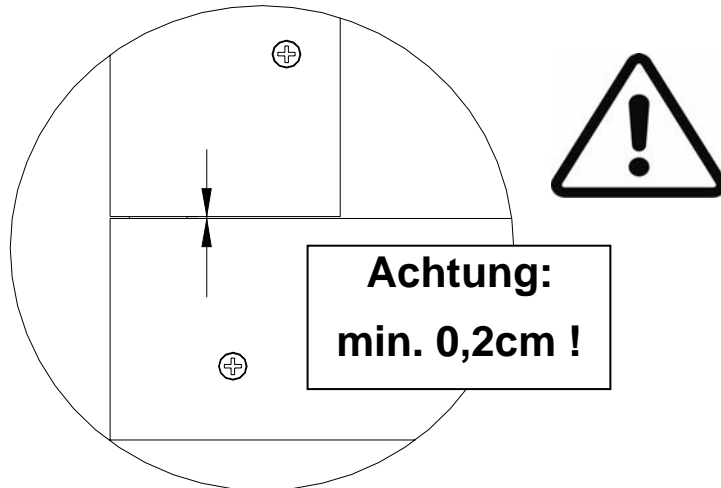
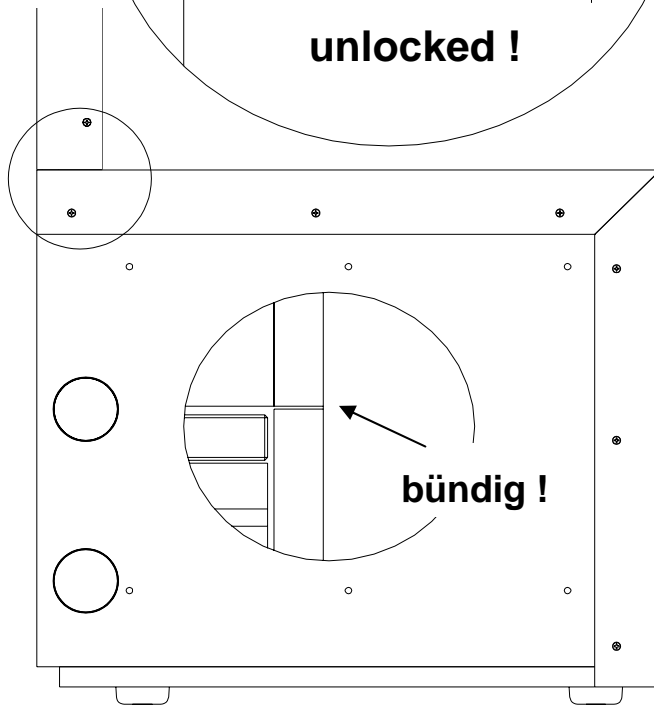
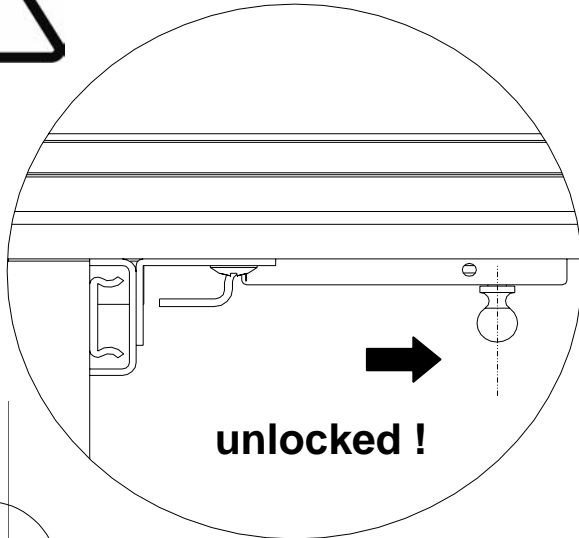
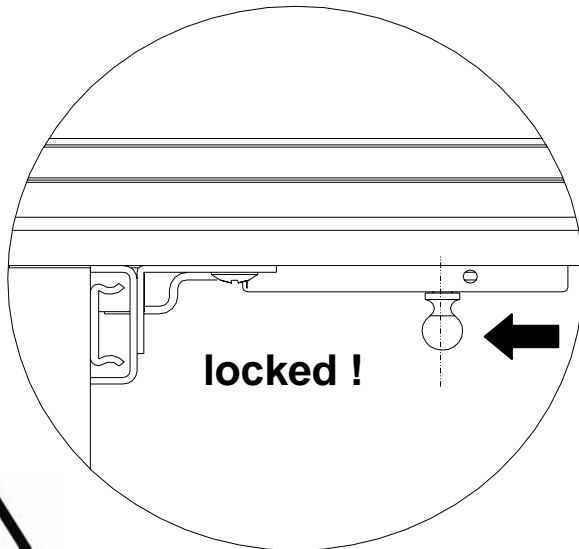

9.

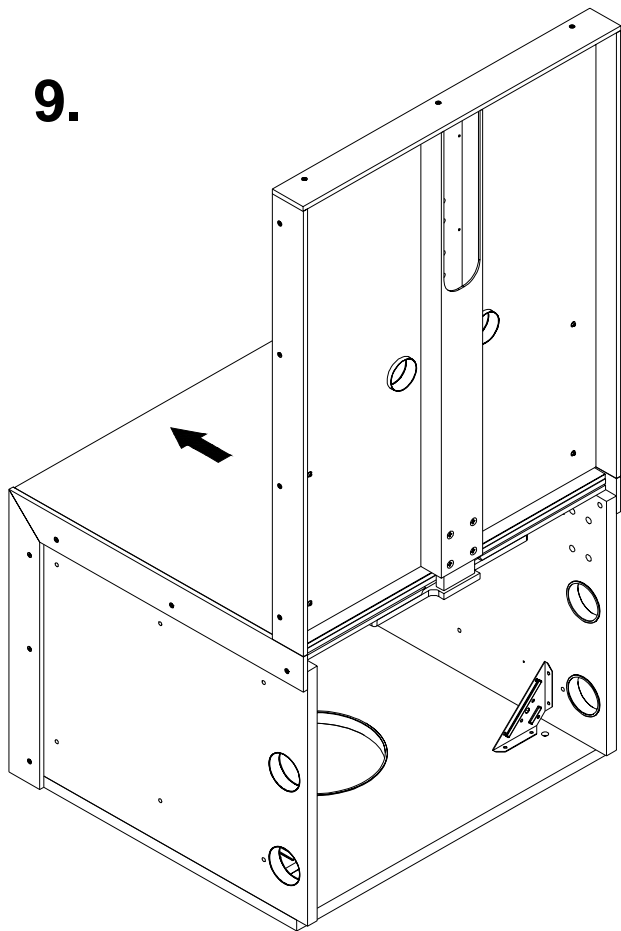

# Q-Media

## Hängeelement mit Glastür



# Musterring

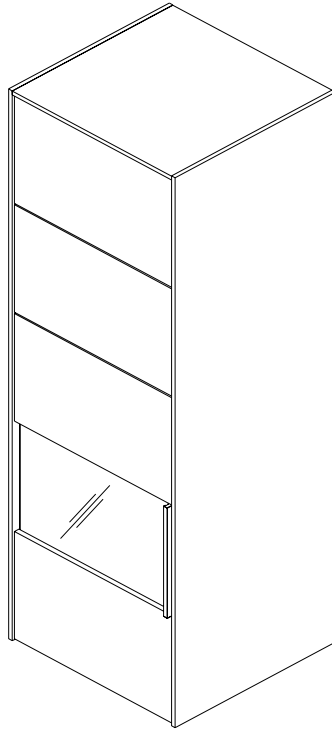
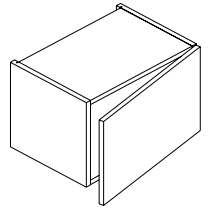
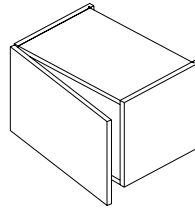

**Type 151**

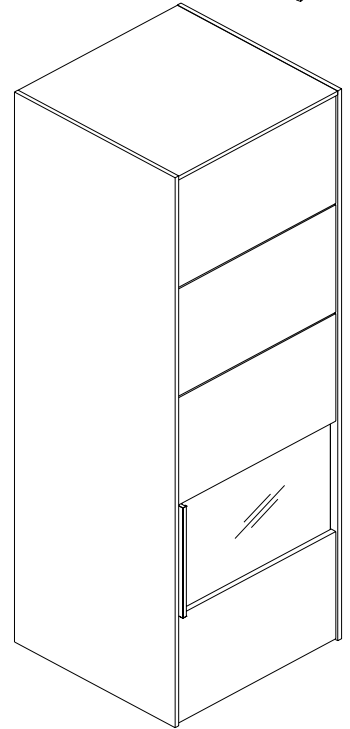

**Type 152**

Sehr geehrte Kundin, sehr geehrter Kunde,

Das beigefügte Wandbefestigungsmaterial (Dübel und Schrauben) eignet sich nur für festes Mauerwerk (z.B. Beton- oder Ziegelwände). Für andere Wandaufbauten sind eventuell Spezialdübel und andere Schrauben notwendig. Ziehen Sie gegebenenfalls eine Fachkraft zurate. Technische Änderungen vorbehalten.

Dear customer,

the provided mounting material (dowels and screws) can only be used with solid masonry (e.g. concrete or brick walls). For other wall constructions special dowels and screws are needed. Please consider an expert in these cases. Leaving technical changes.

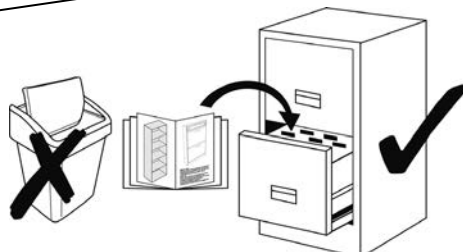
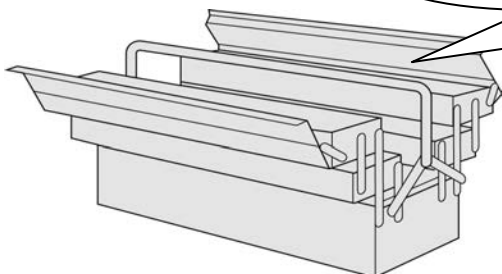
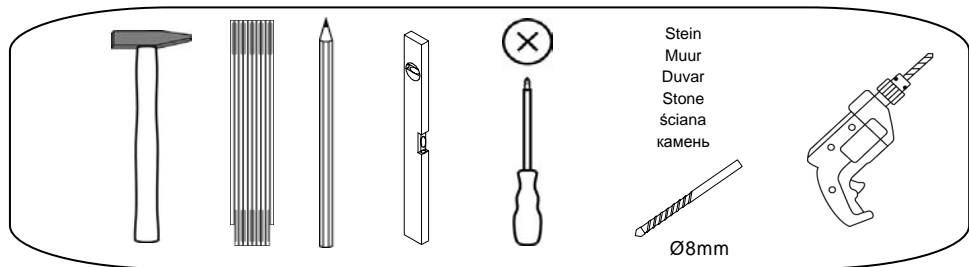
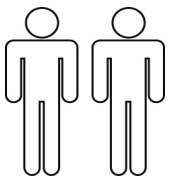



## Type 151

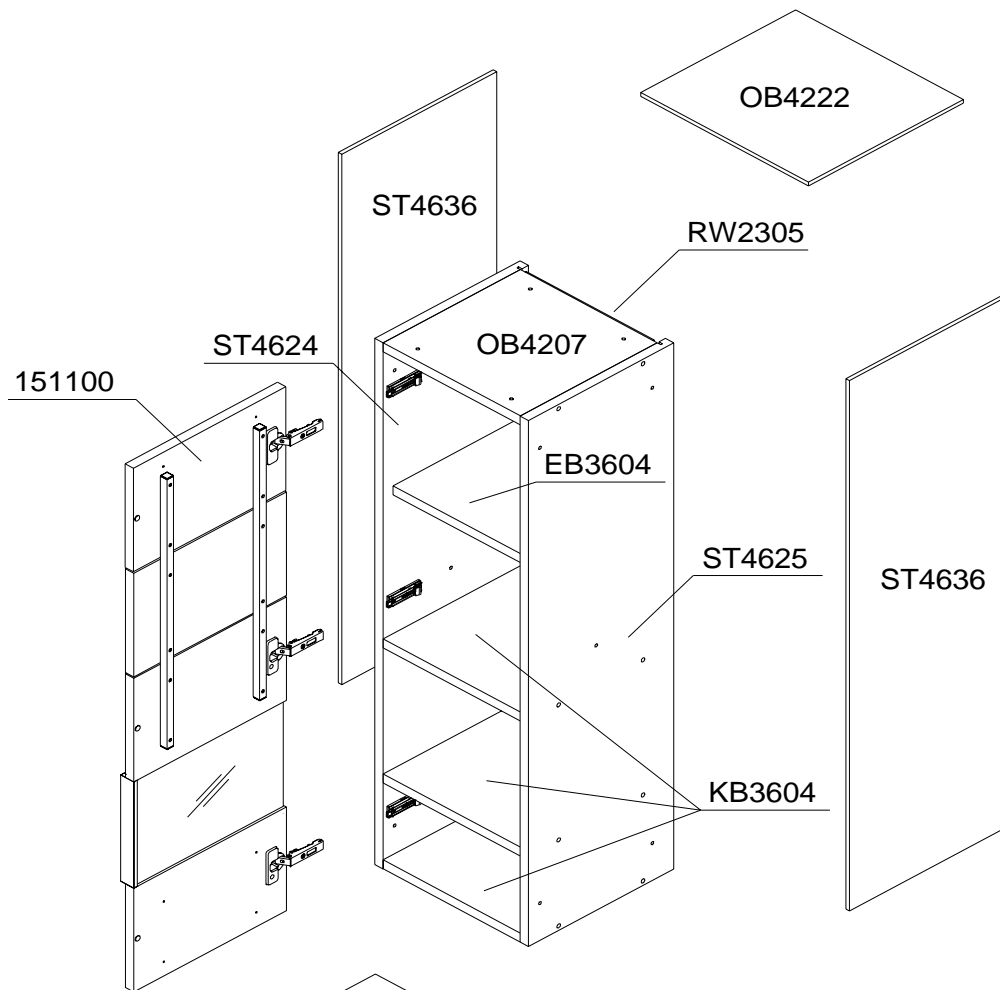

## Type 152

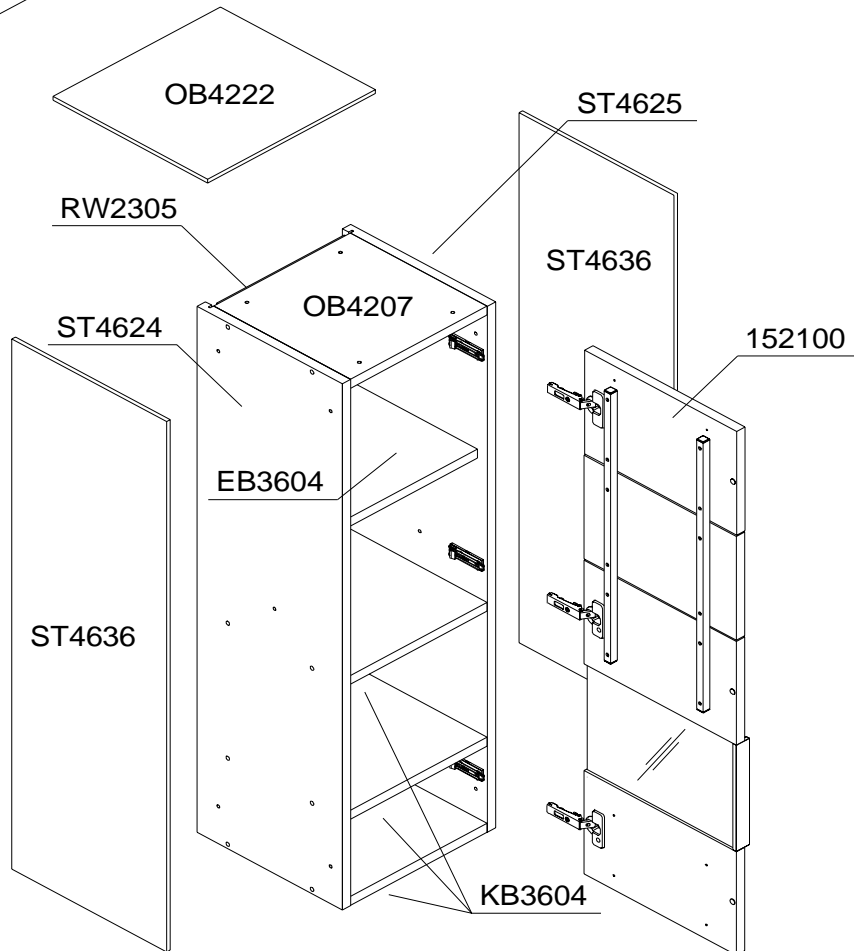

## Beschlagteile Typ 151-152

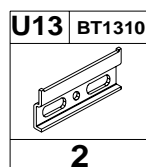
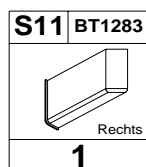
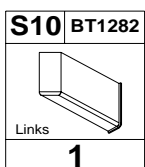
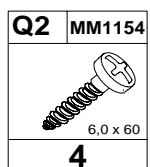

Demontage:  
Dismounting:



1.A.

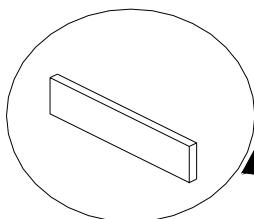

Type 151

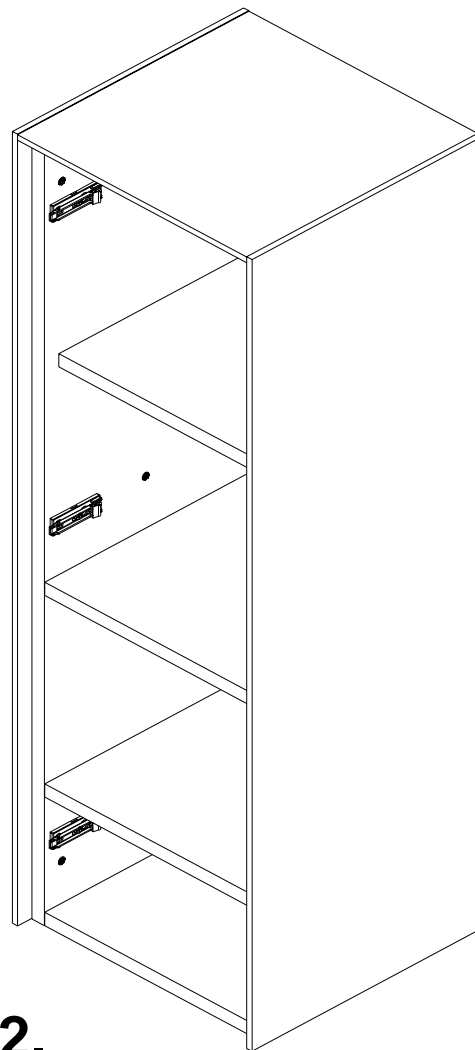

2.

B.

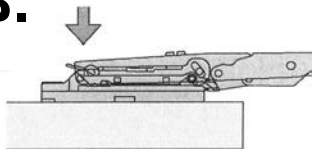

Das Lösen des Bandarmes von der Montage  
Druck auf die beiden mit Pfeil bezeichneten

C.

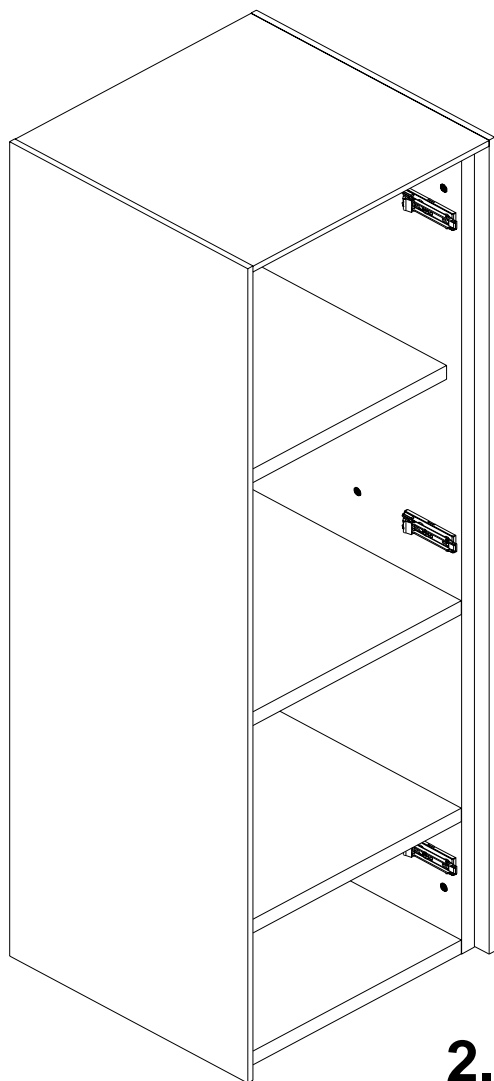
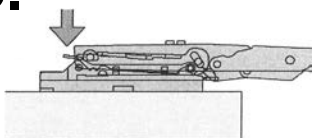

2.

Type 152

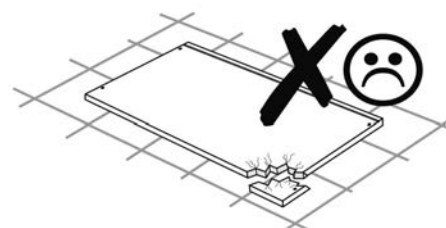
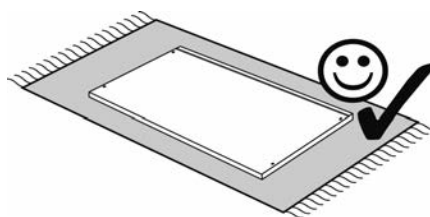

# Q-Media

Power-LED SET -warm weiss-

 **Musterring**

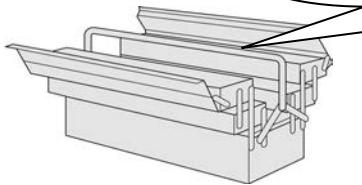
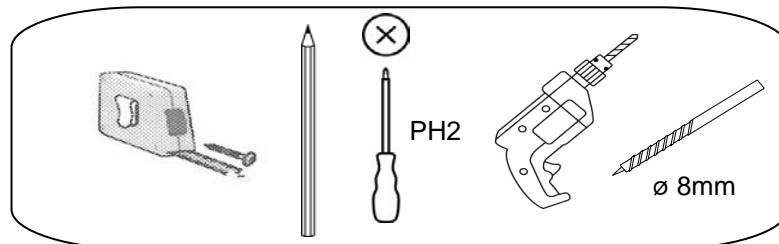
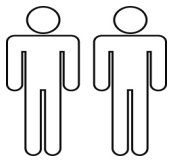
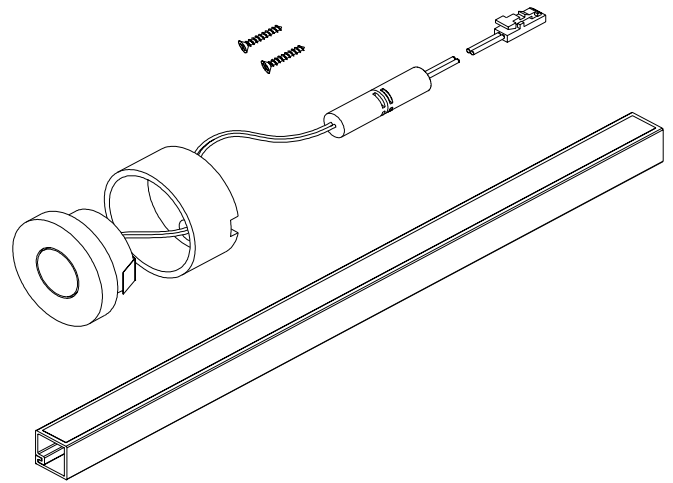

35 cm

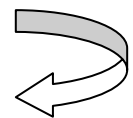
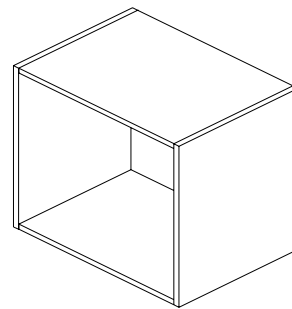
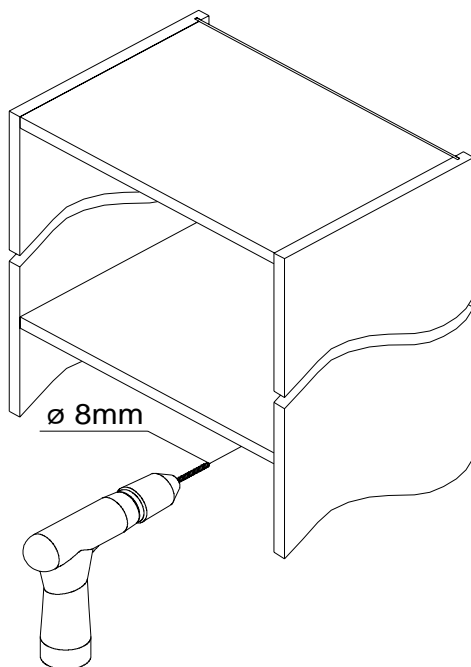

60 cm

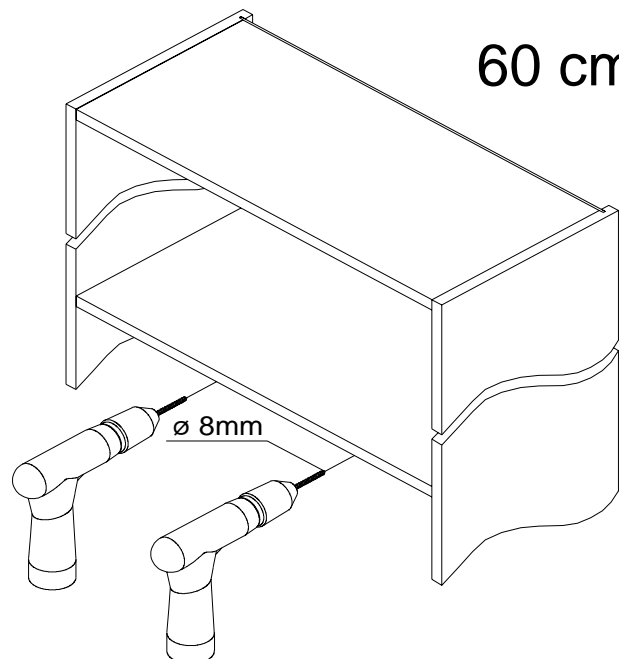

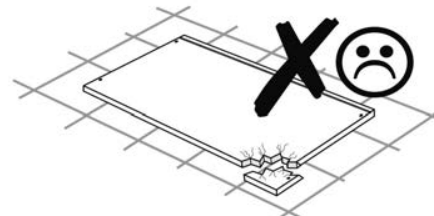
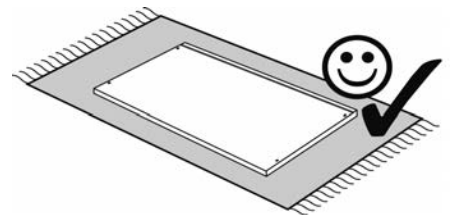
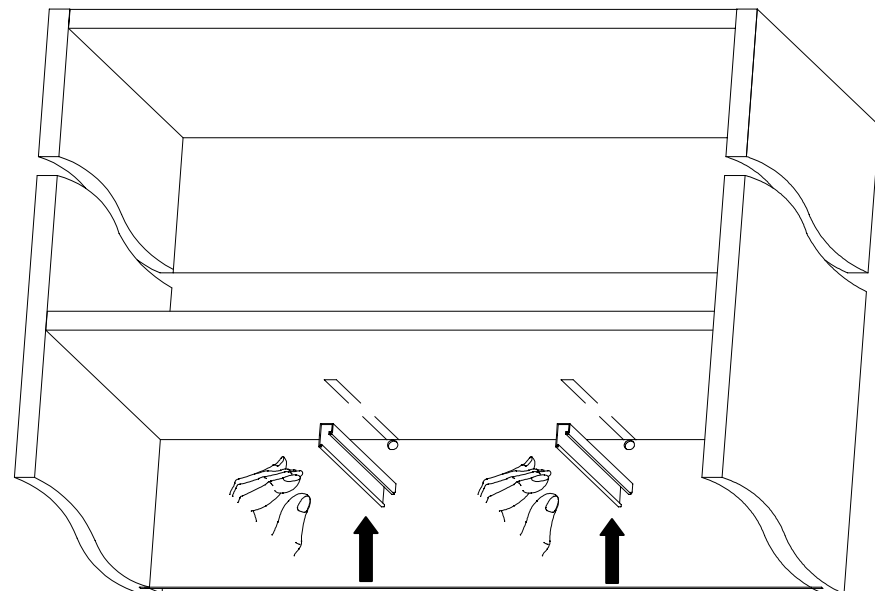
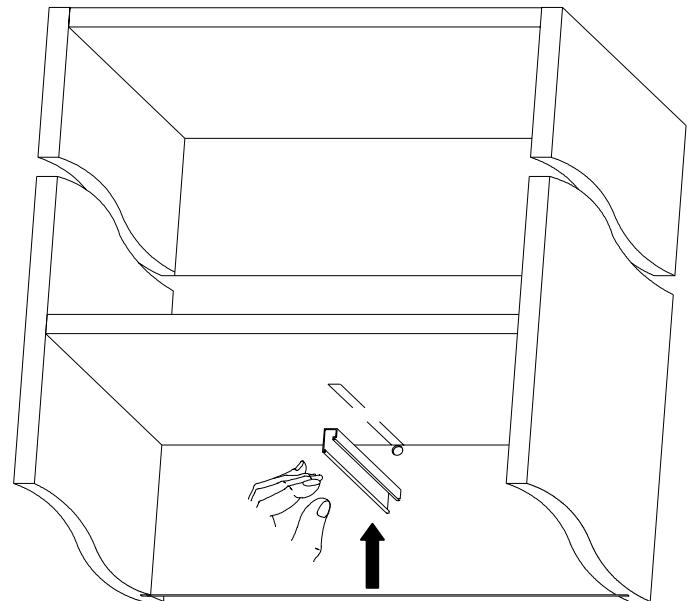
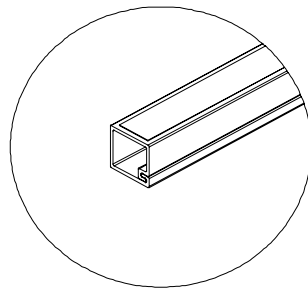
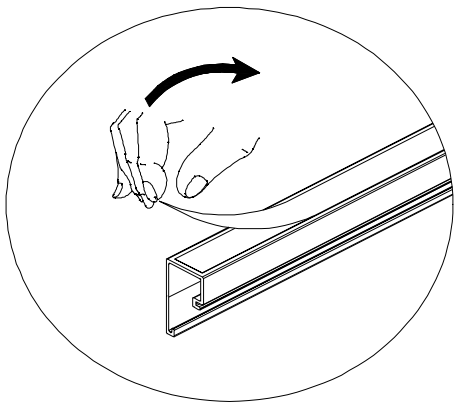
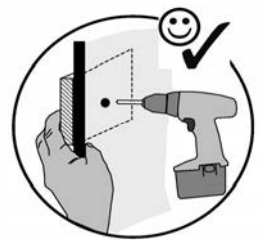
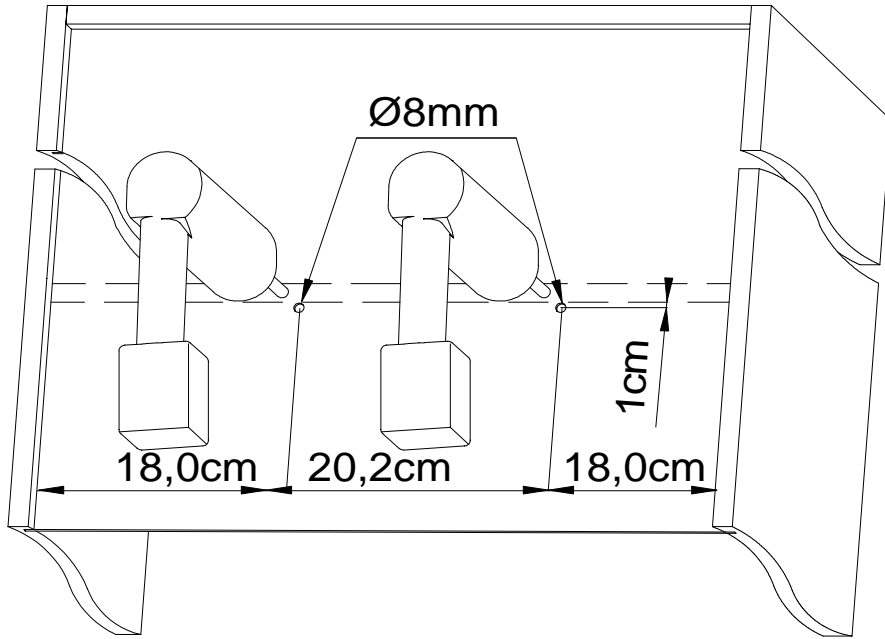
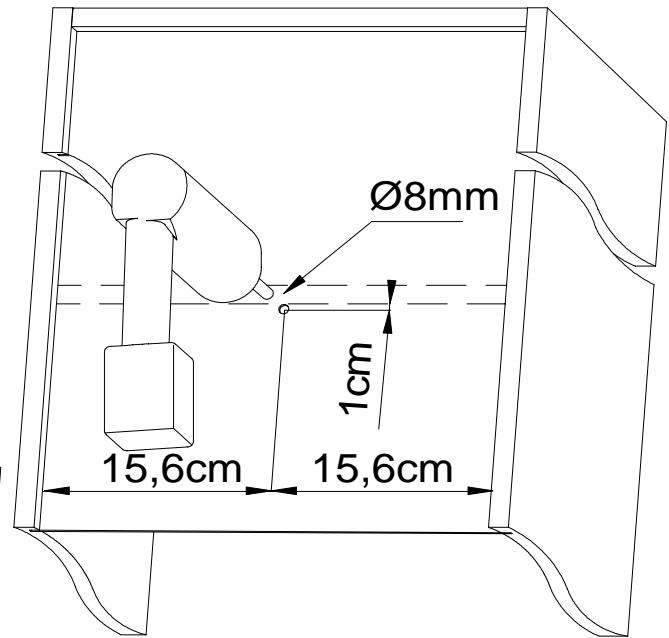
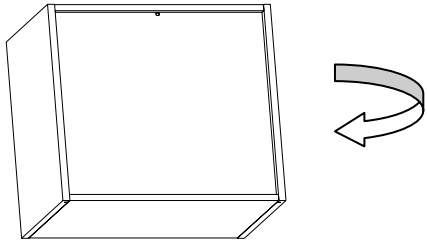

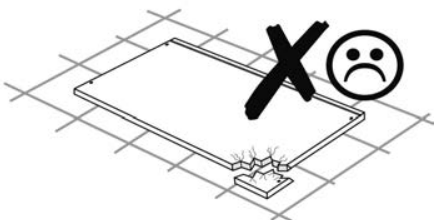
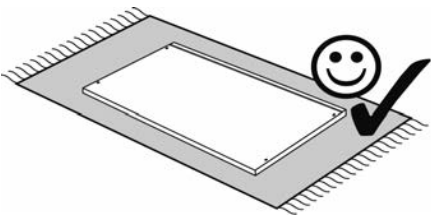
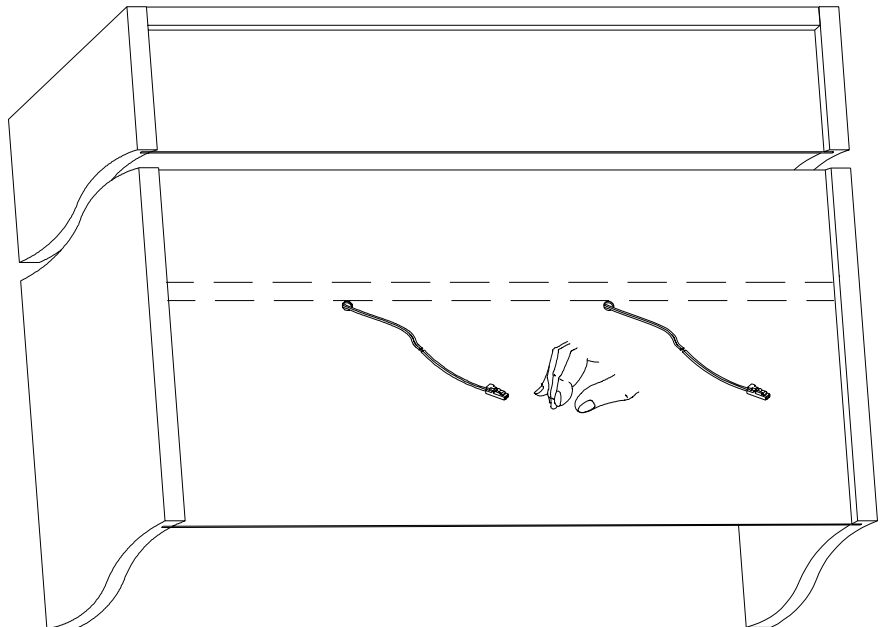
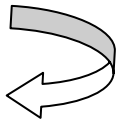
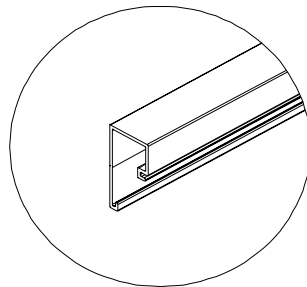
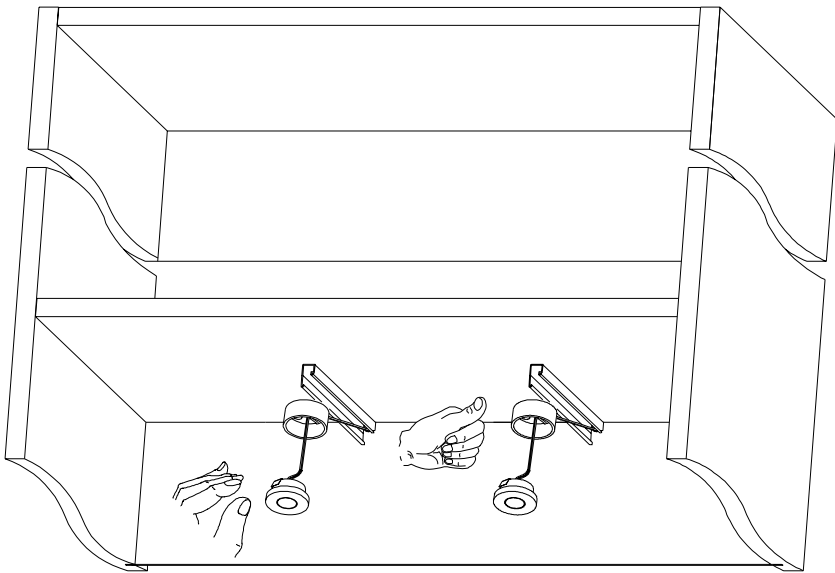
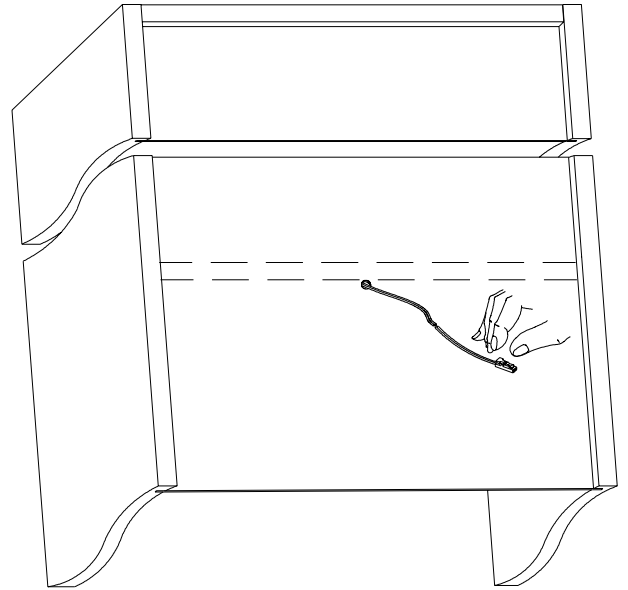
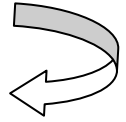
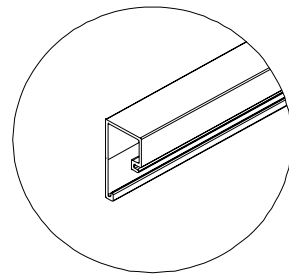
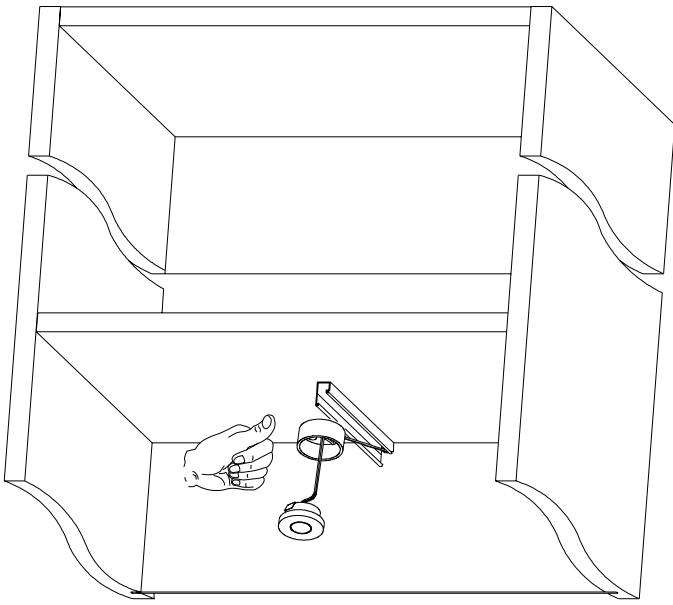

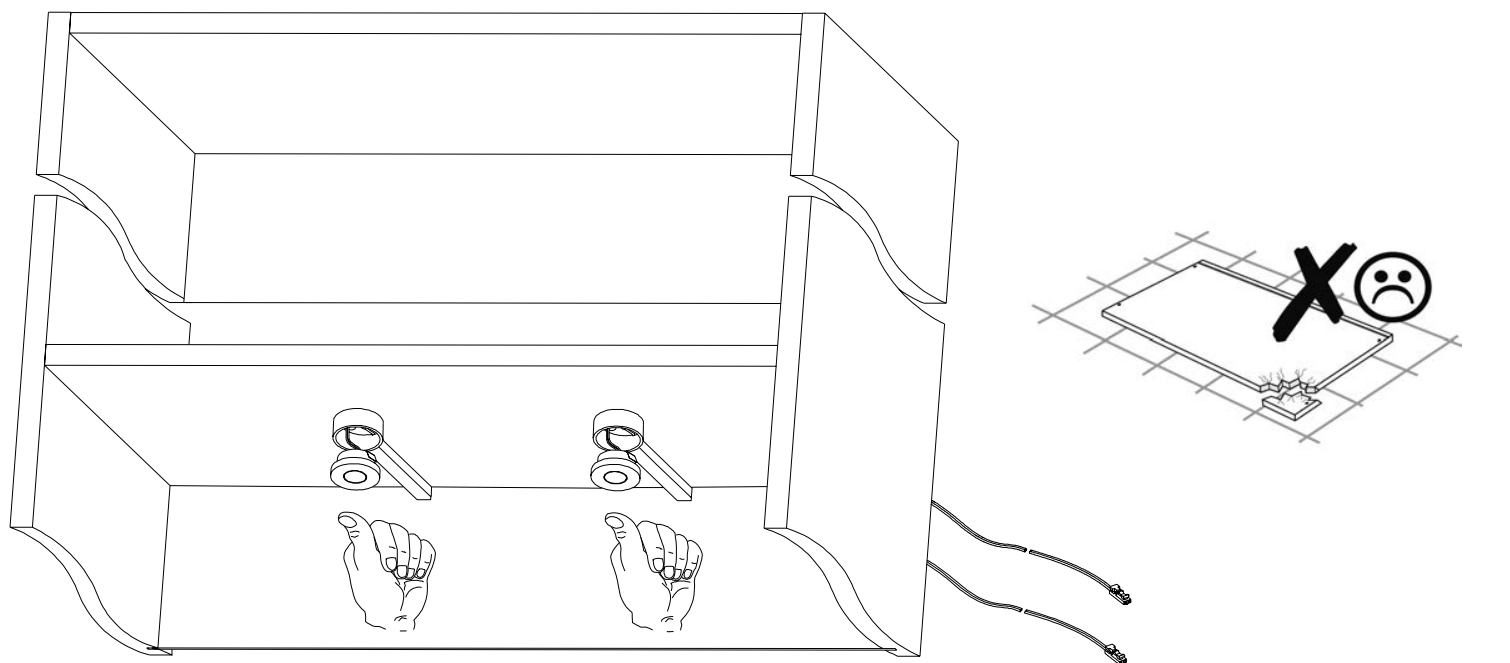
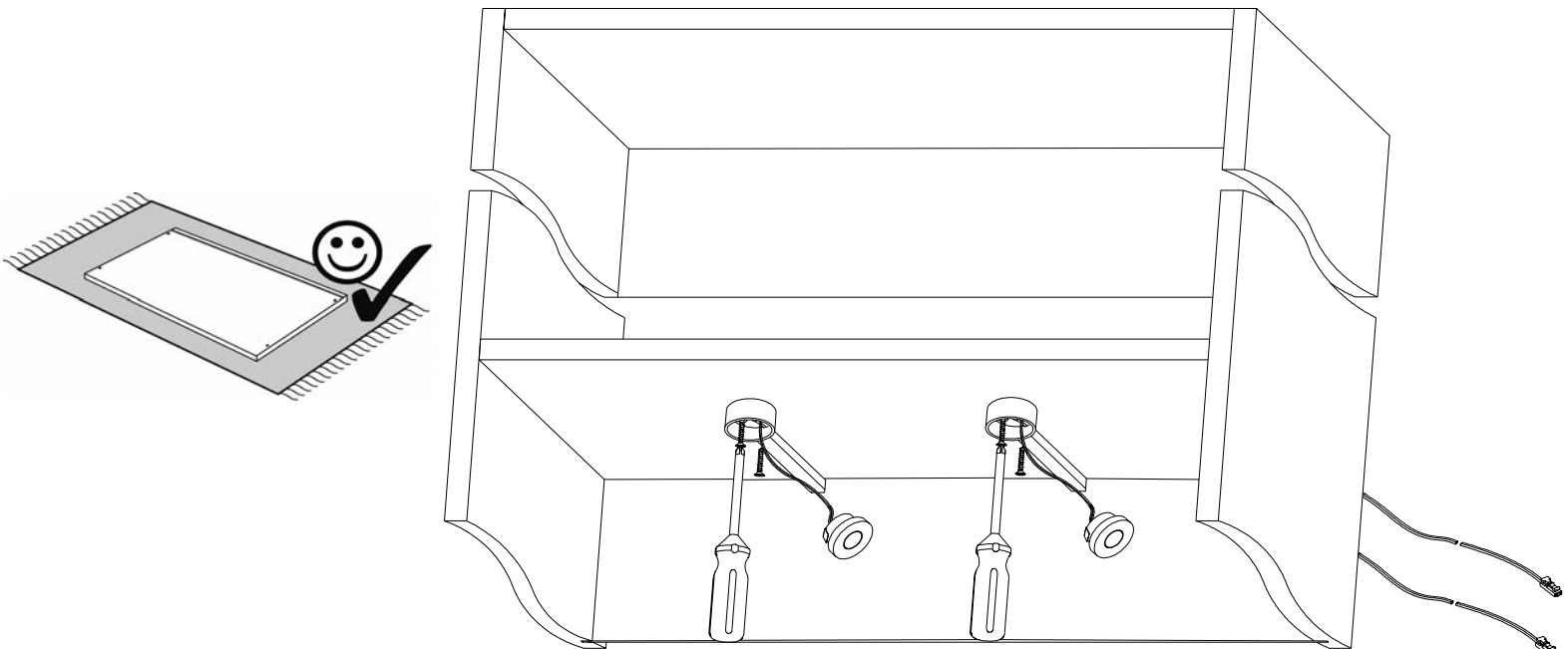
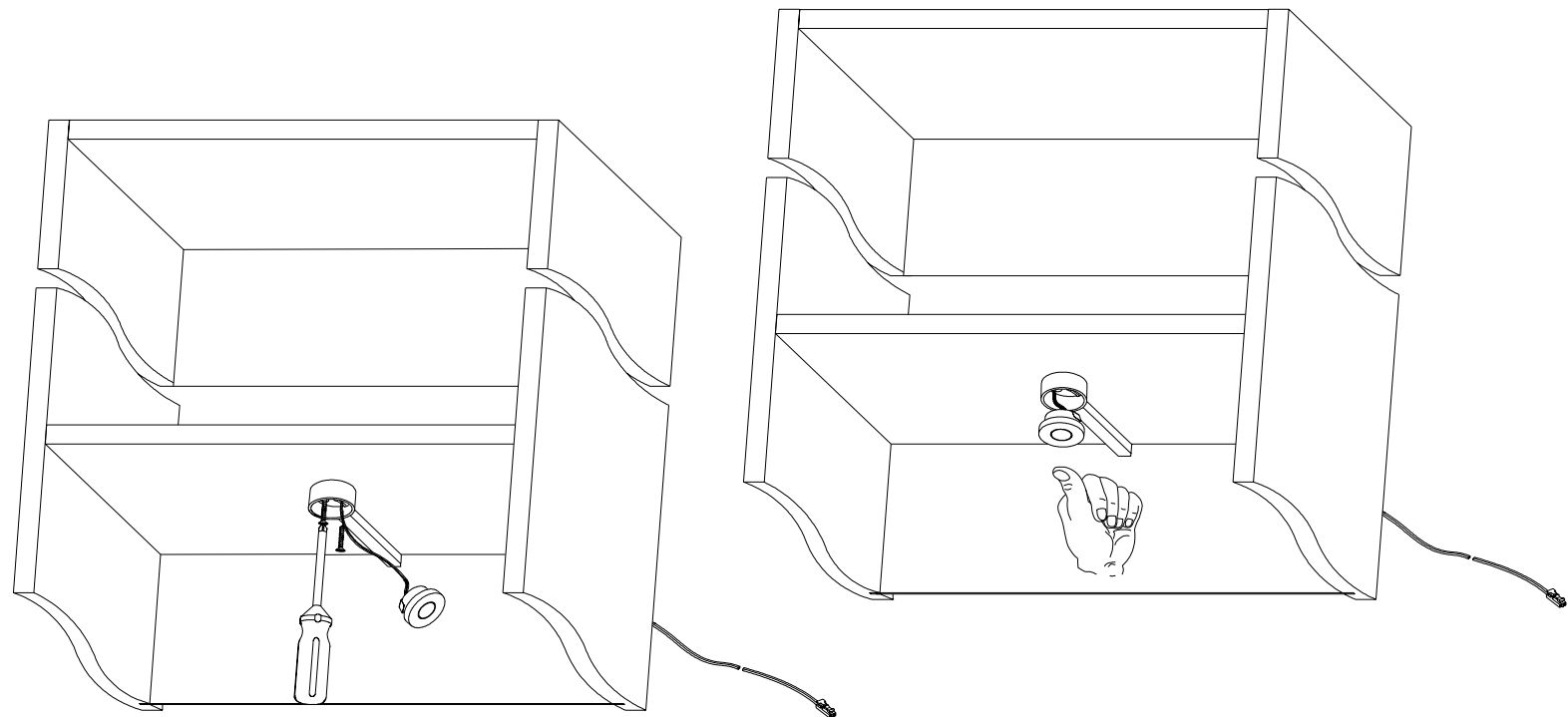

185 cm

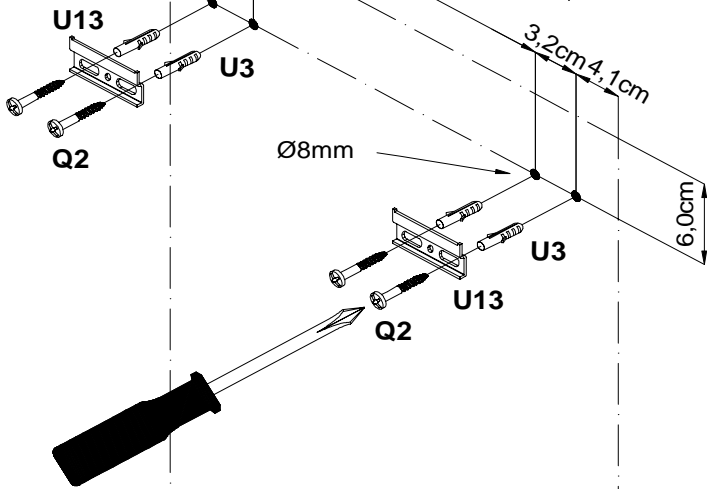

Ø8mm

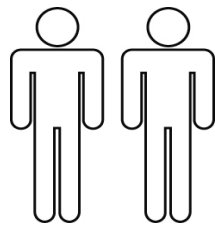
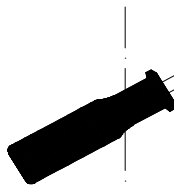

Type 151/152

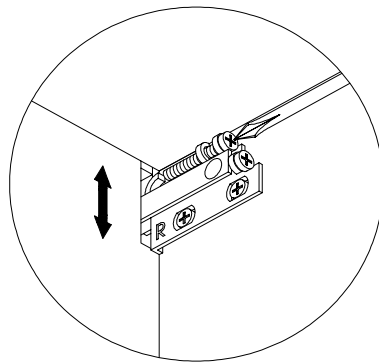
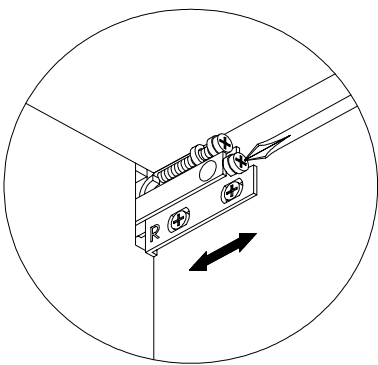

Ausrichten des Hängeschrankes  
 durch die Stellschrauben am  
 Aufhängebeschlag:  
 Adjustment of the wall cupboard  
 with set-screws on the fitting:

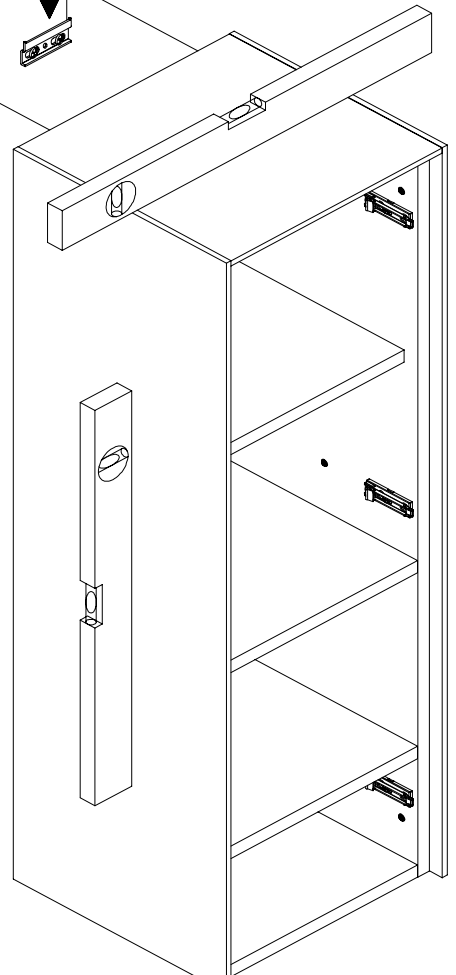
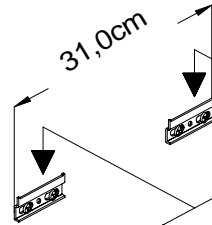
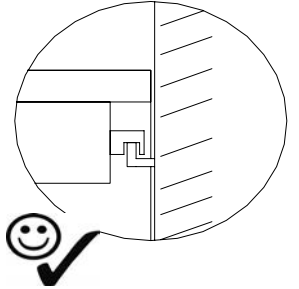
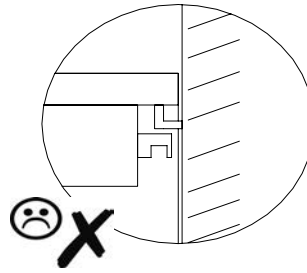
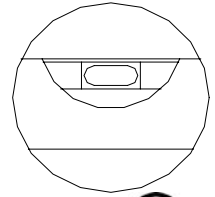
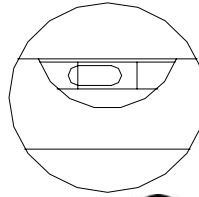
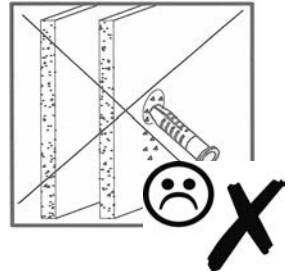
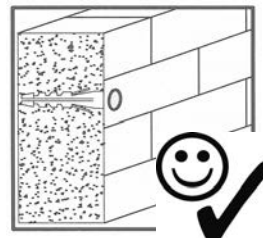
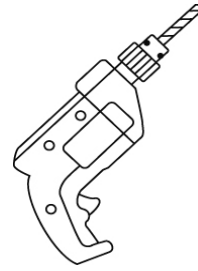
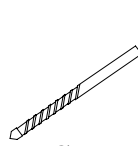

Die beiden mit Pfeil bezeichneten Punkte ir

# 1.A.

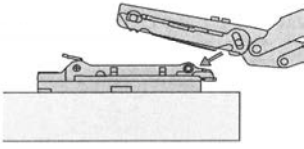

Eine leichte Drehung ausführen

# B.

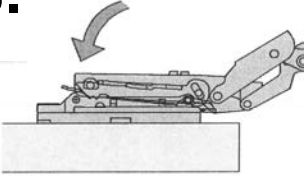

und leicht andrücken.

# C.

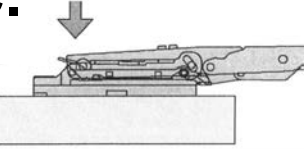

Das Lösen des Bandarmes von der Montage  
Druck auf die beiden mit Pfeil bezeichneten

# D.

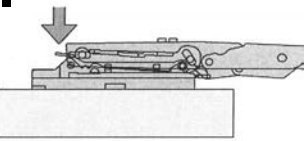

## Montage: Assembly:

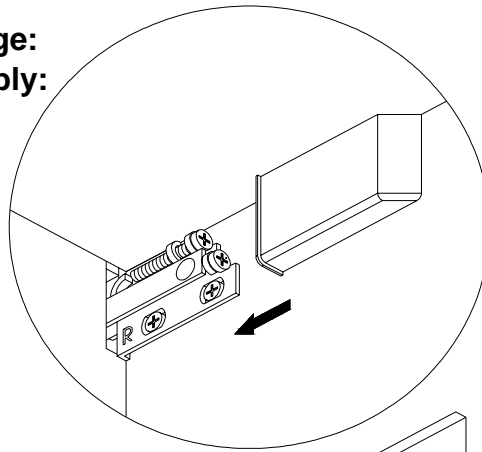

# 4.

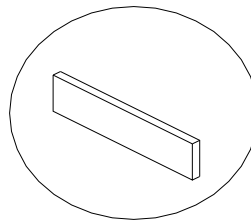

## Type 151

# 5.

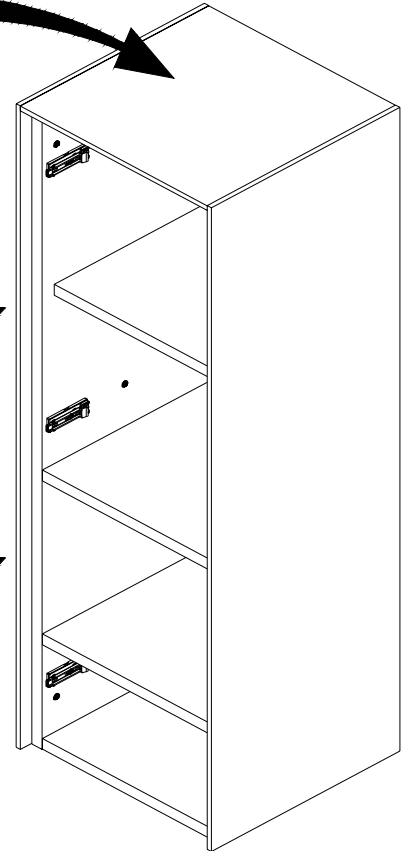

## Demontage: Dismounting:

## Verstellung der Tür: Adjustment of the door:

### Height adjustment:

Eine Höhenverstellung der Tür von  $\pm 2$  mm ist mittels Exzenter möglich, ohne jegliche Schrauben lösen zu müssen.

# 2.

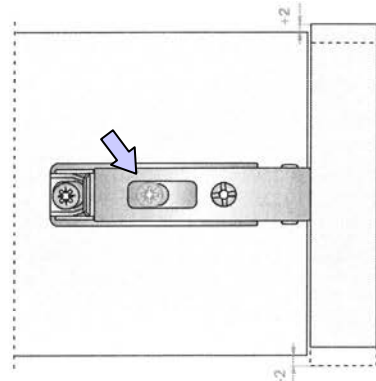
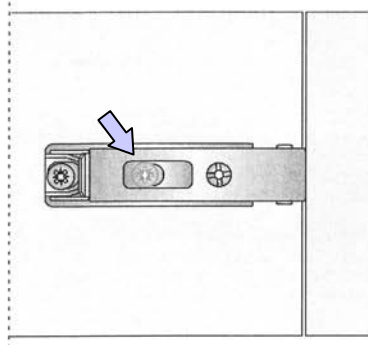
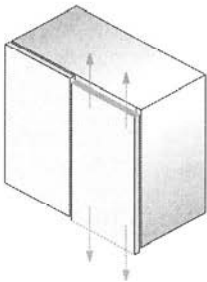

### Depth adjustment:

Eine Tiefenverstellung der Tür von -0,5 mm bis zu +2,8 mm ist mittels Exzenter möglich, ohne jegliche Schrauben lösen zu müssen.

# 3.

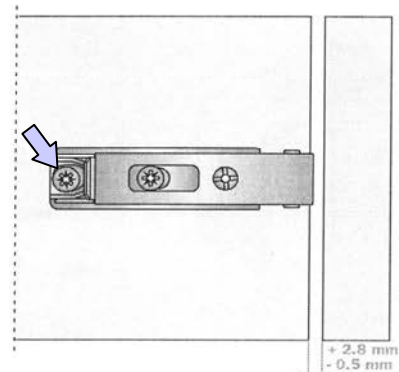
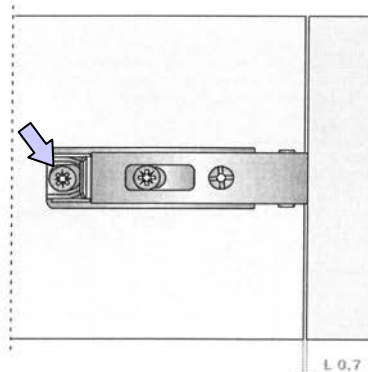
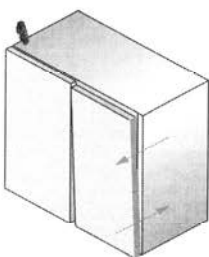



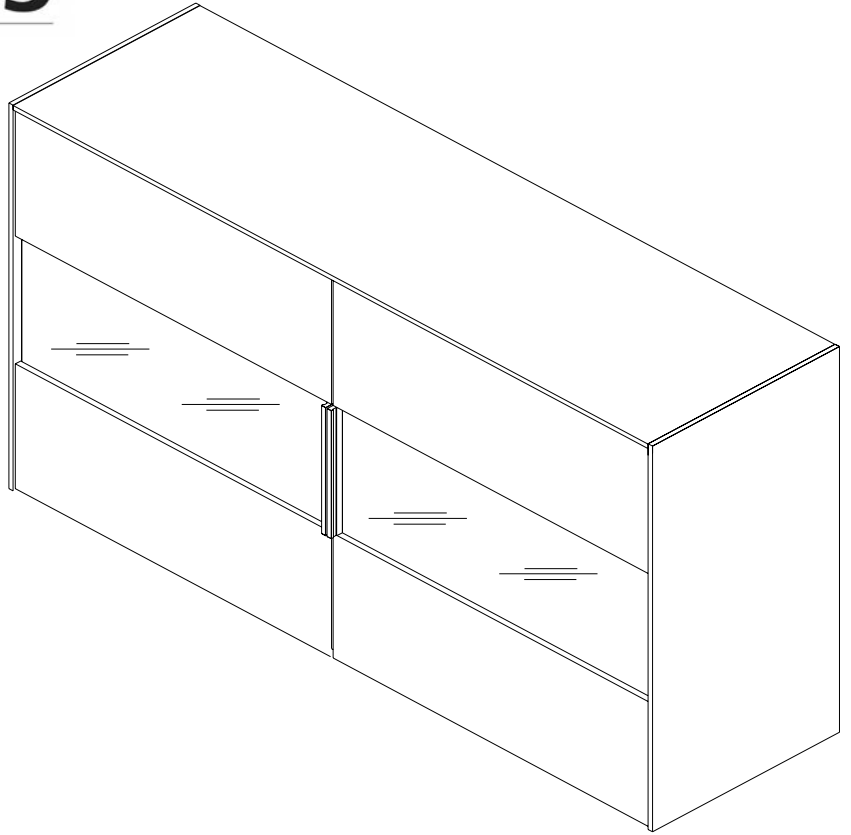

Type 732

Sehr geehrte Kundin, sehr geehrter Kunde,

Das beigefügte Wandbefestigungsmaterial (Dübel und Schrauben) eignet sich nur für festes Mauerwerk (z.B. Beton- oder Ziegelwände). Für andere Wandaufbauten sind eventuell Spezialdübel und andere Schrauben notwendig. Ziehen Sie gegebenenfalls eine Fachkraft zurate. Technische Änderungen vorbehalten.

Dear customer,

the provided mounting material (dowels and screws) can only be used with solid masonry (e.g. concrete or brick walls). For other wall constructions special dowels and screws are needed. Please consider an expert in these cases. Leaving technical changes.

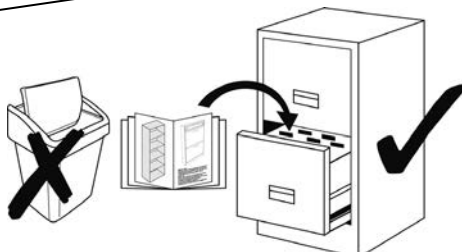
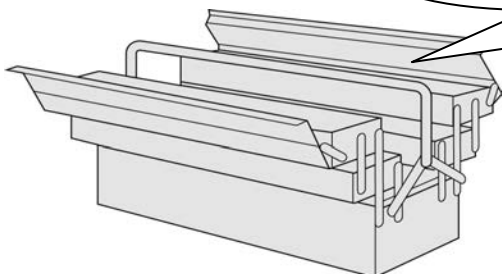
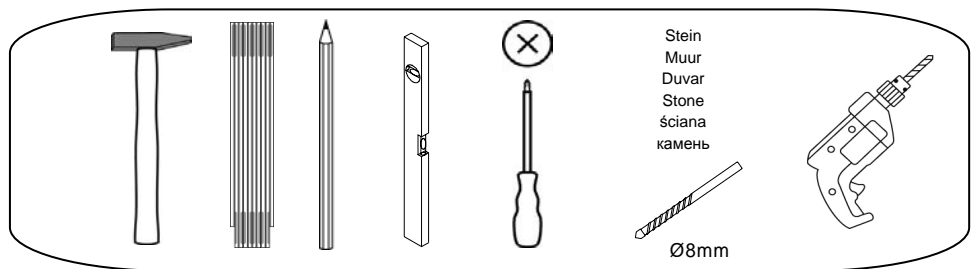
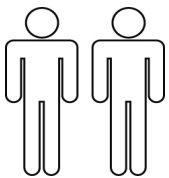

# Type 732

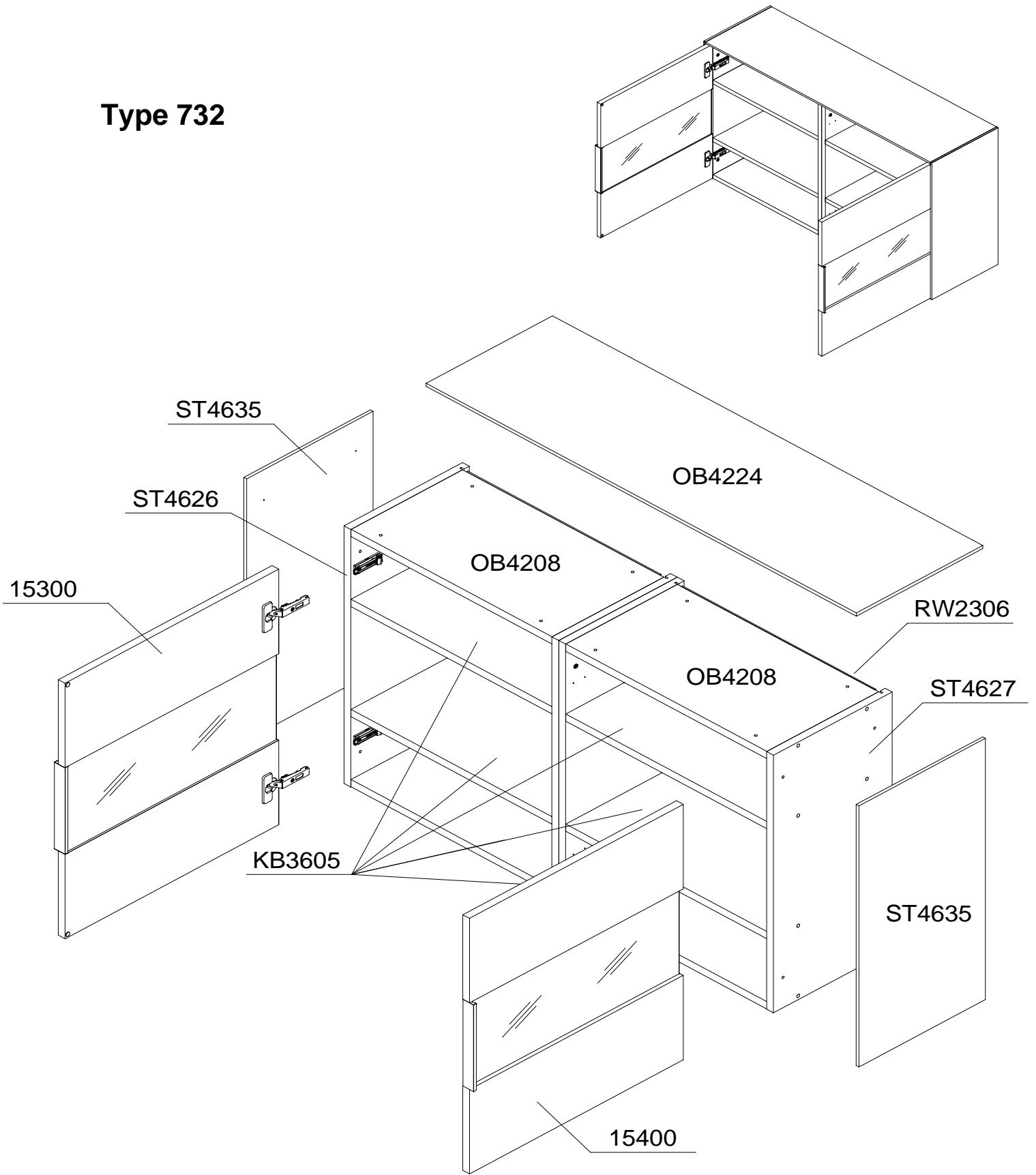

## Beschlagteile Typ 732

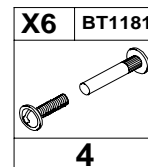
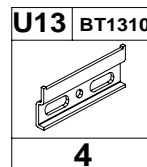
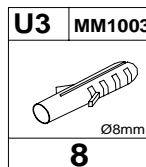
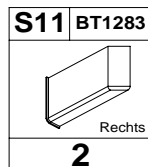
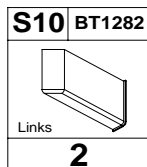
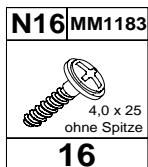
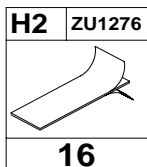

Demontage:  
Dismounting:



1.A.

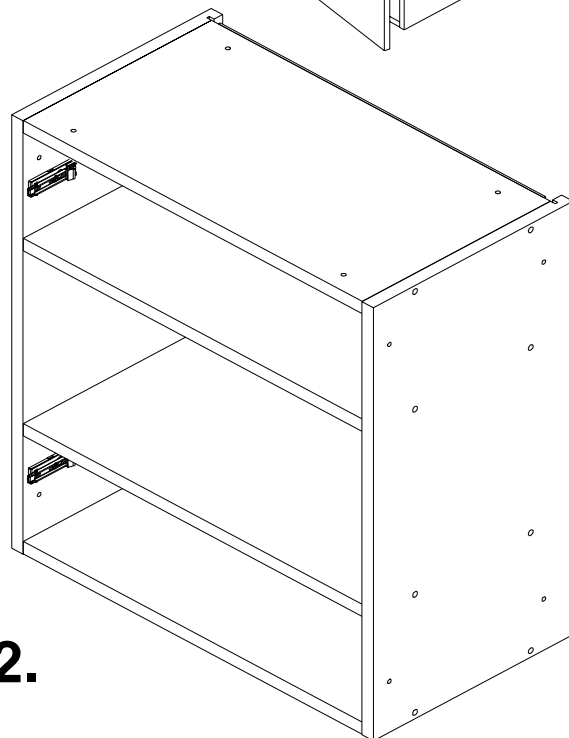
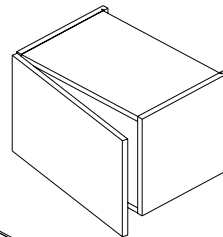
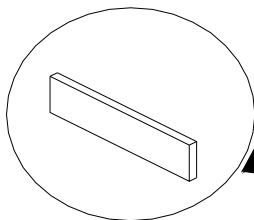

B.

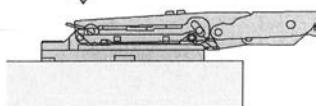

15300

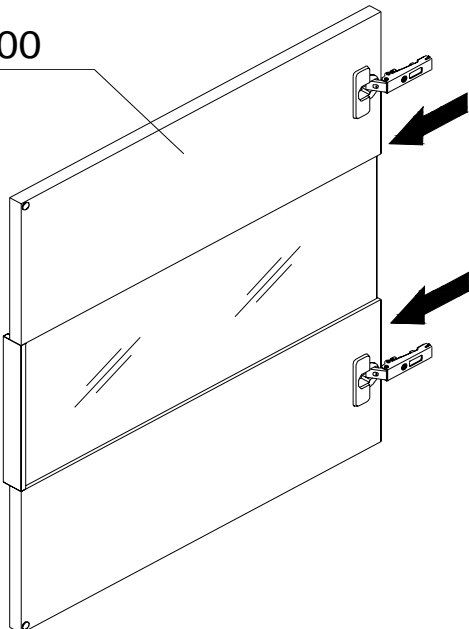

2.

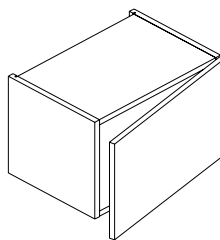

Das Lösen des Bandarmes von der Montage  
Druck auf die beiden mit Pfeil bezeichneten

C.

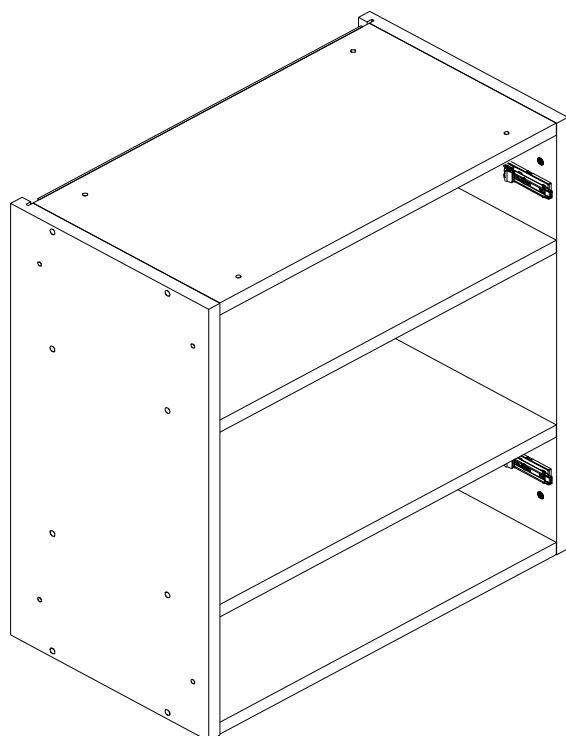
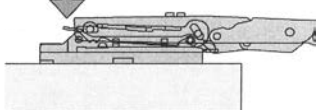

15400

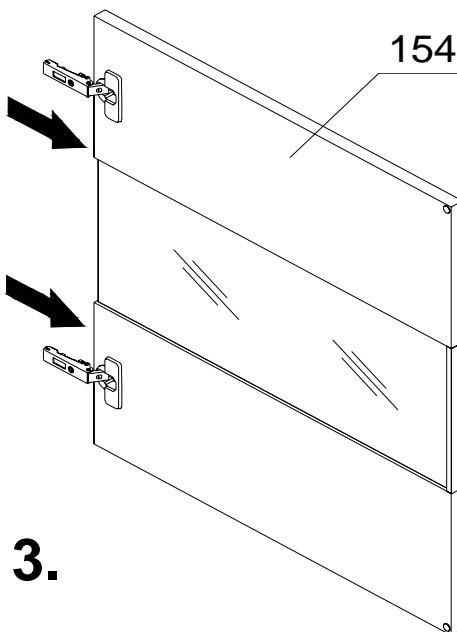

3.

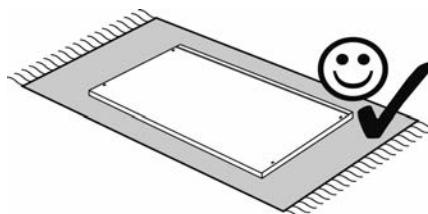
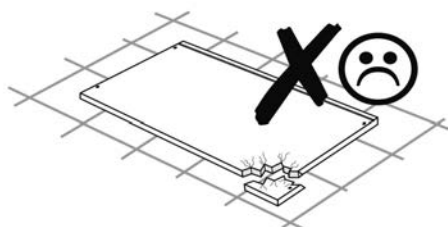

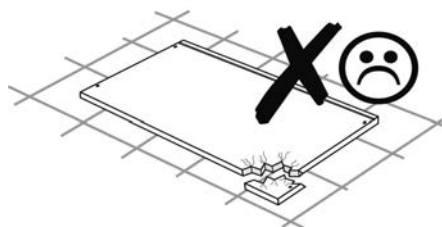
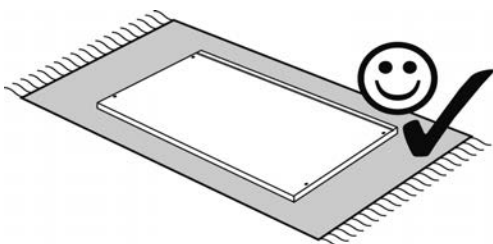
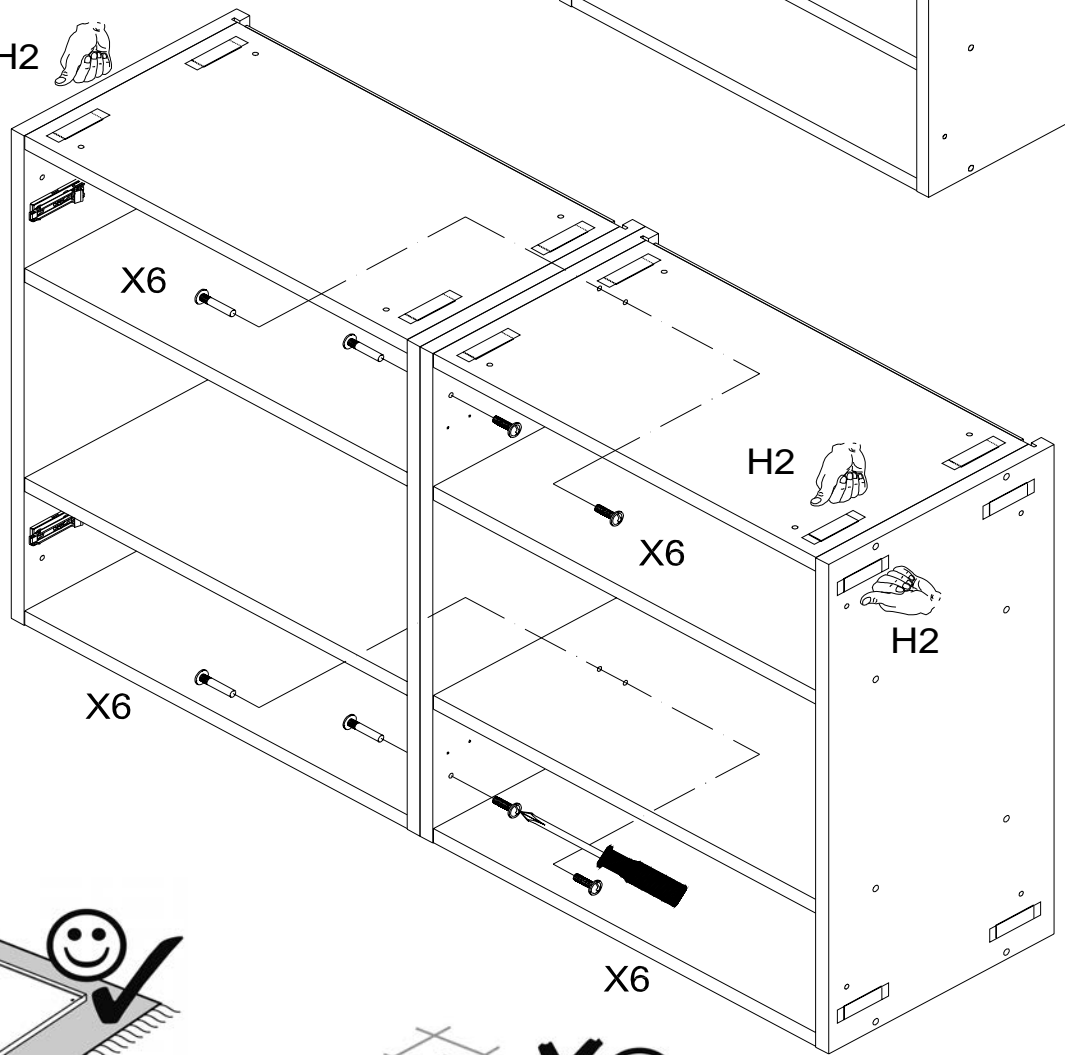
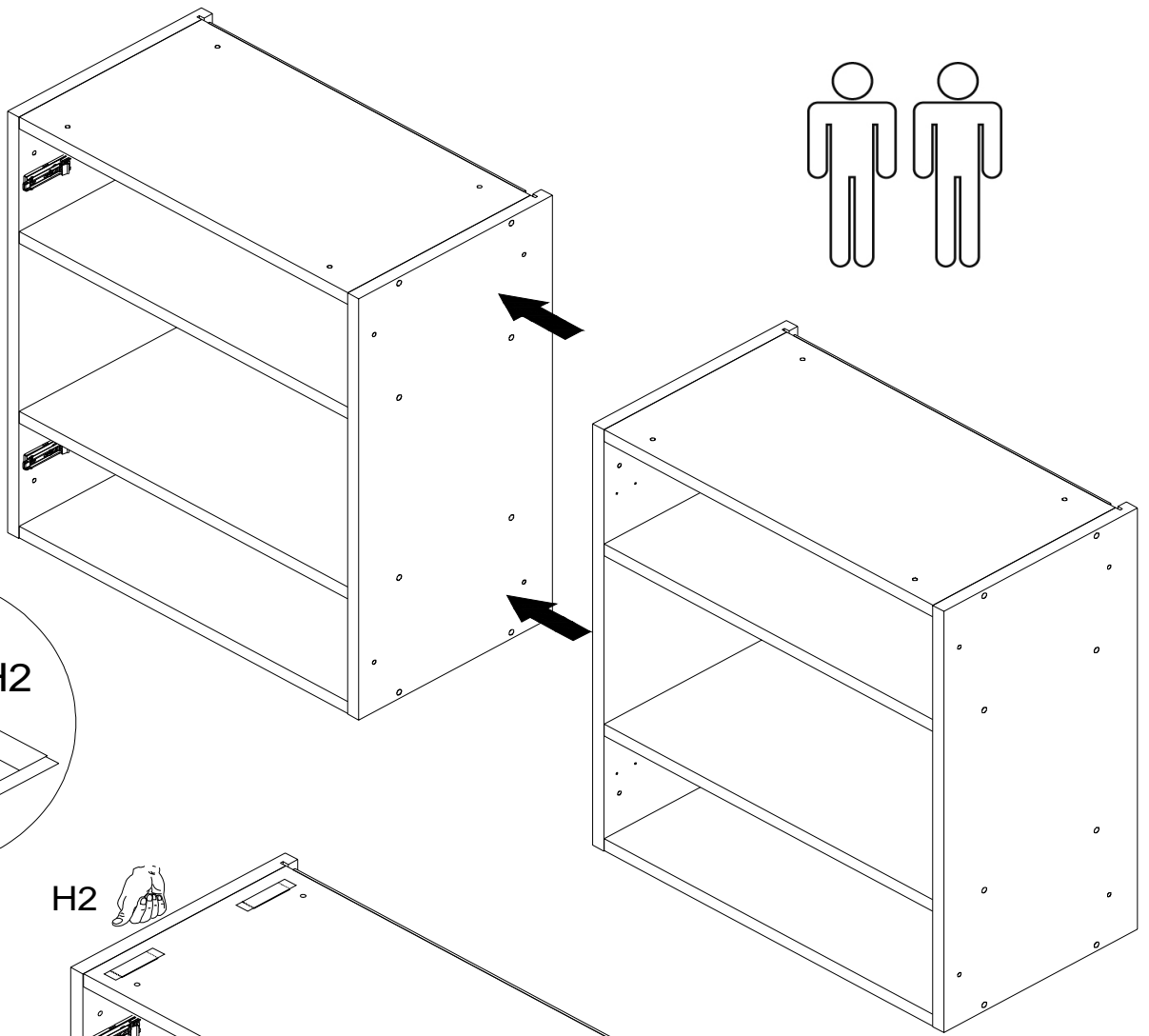
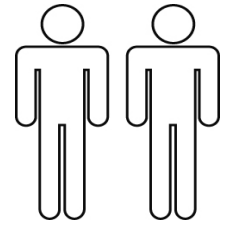

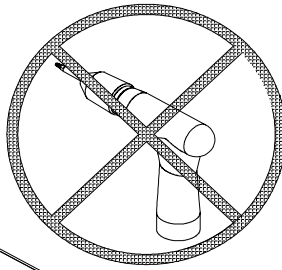

**Die Schrauben zur Befestigung der Seiten und Böden nur mit einem Handschraubendreher anziehen.  
Keinen Elektro- oder Akkuschauber verwenden.**

**Only use a hand screwdriver to attach the screws . Do not use an electric or cordless screwdriver.**

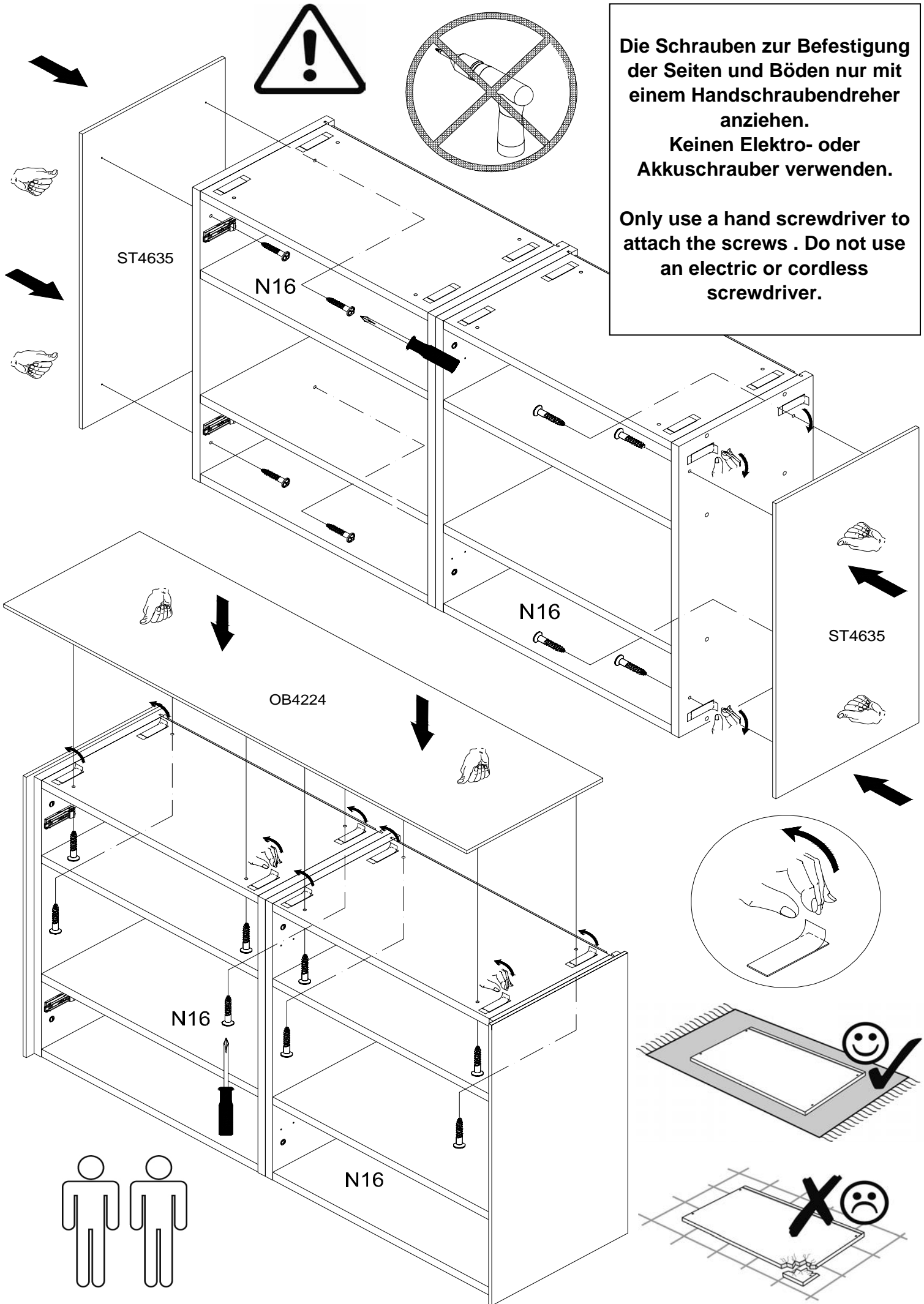

1R => 130 cm ; 2R => 155 cm ; 3R => 180 cm

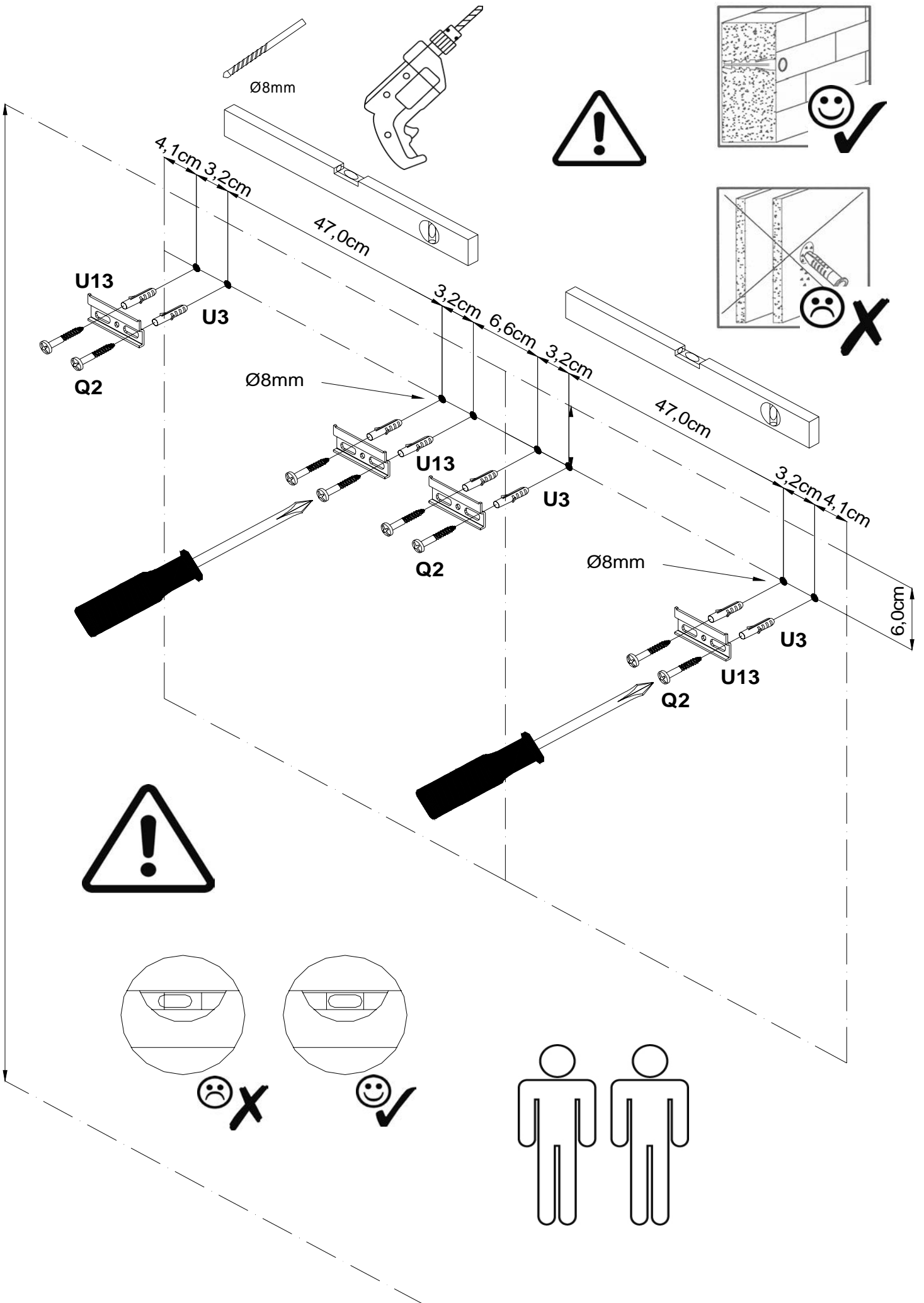

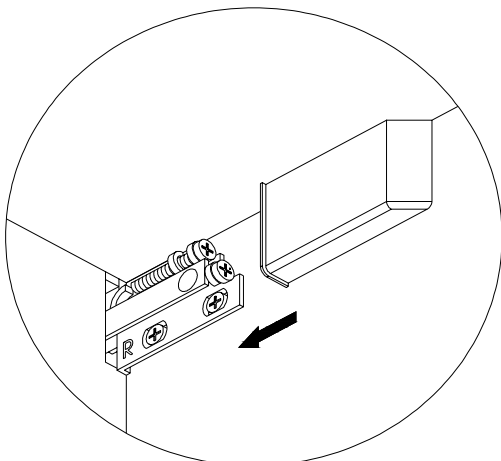
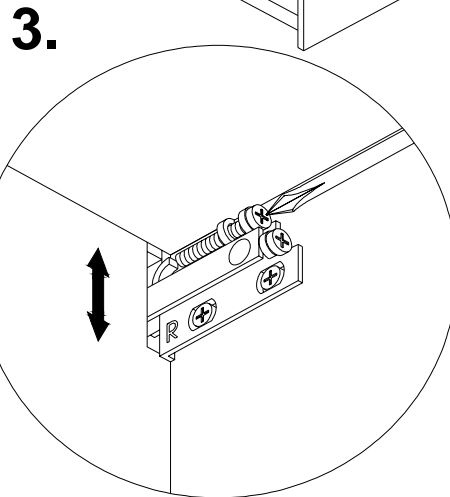
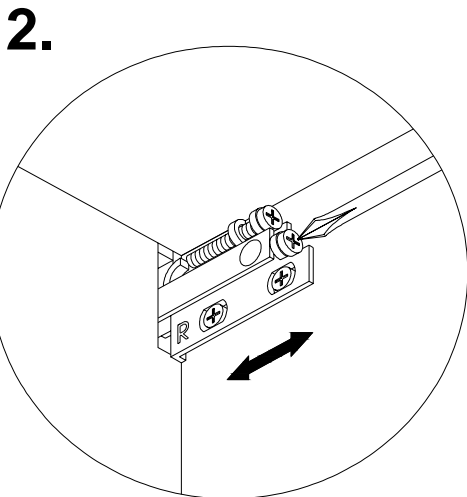
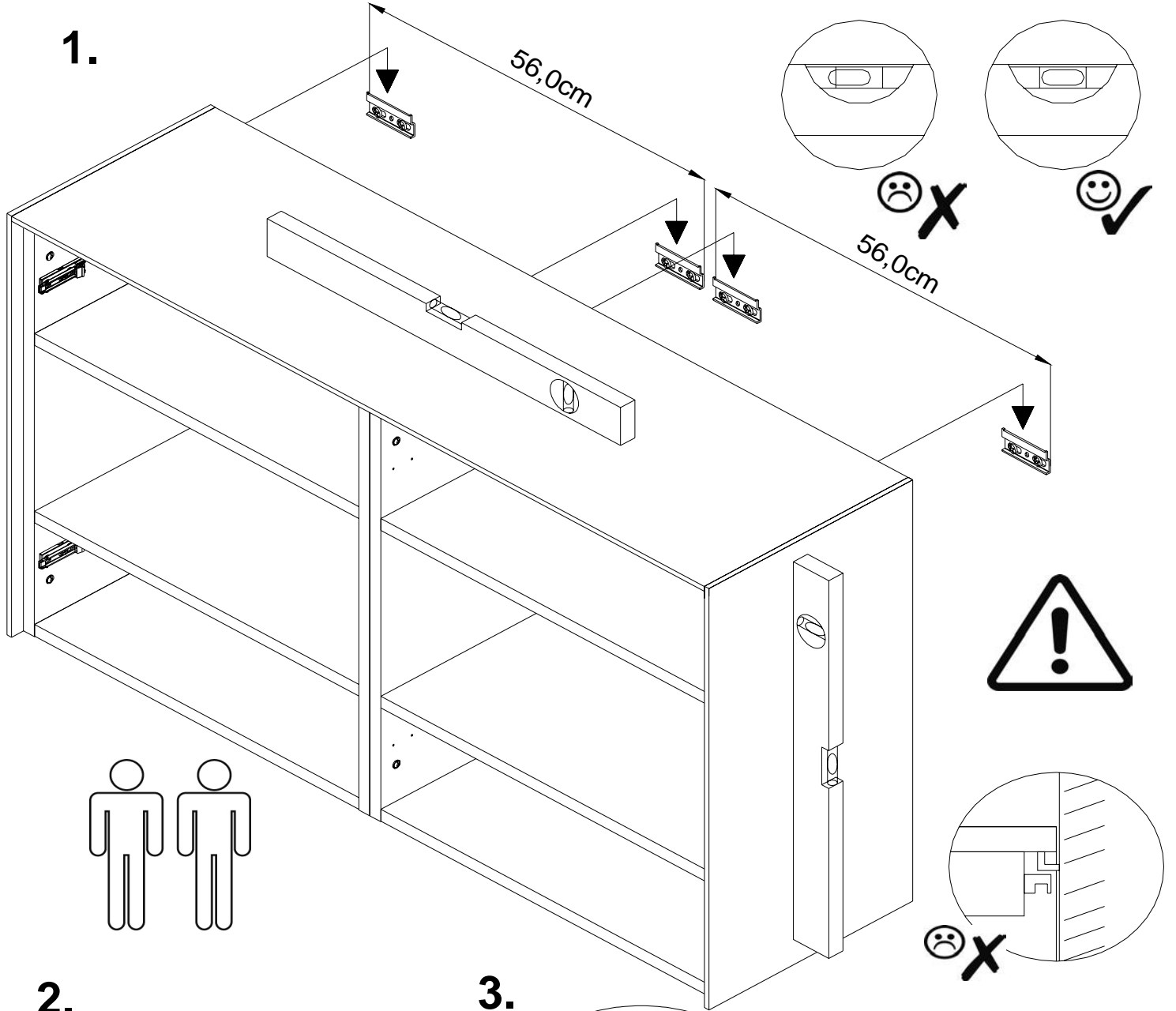

**Ausrichten des Hängeschrankes durch die Stellschrauben am Aufhängebeslag:**  
**Adjustment of the wall cupboard with set-screws on the fitting:**



Die beiden mit Pfeil bezeichneten Punkte ir

# 1.A.

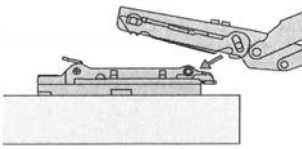

Eine leichte Drehung ausführen

# B.

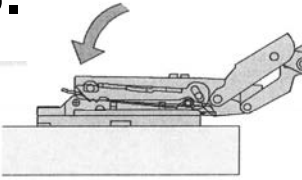

und leicht andrücken.

# C.

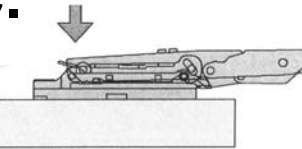

Das Lösen des Bandarmes von der Montage  
Druck auf die beiden mit Pfeil bezeichneten

# D.

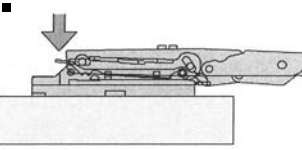

## Montage: Assembly:

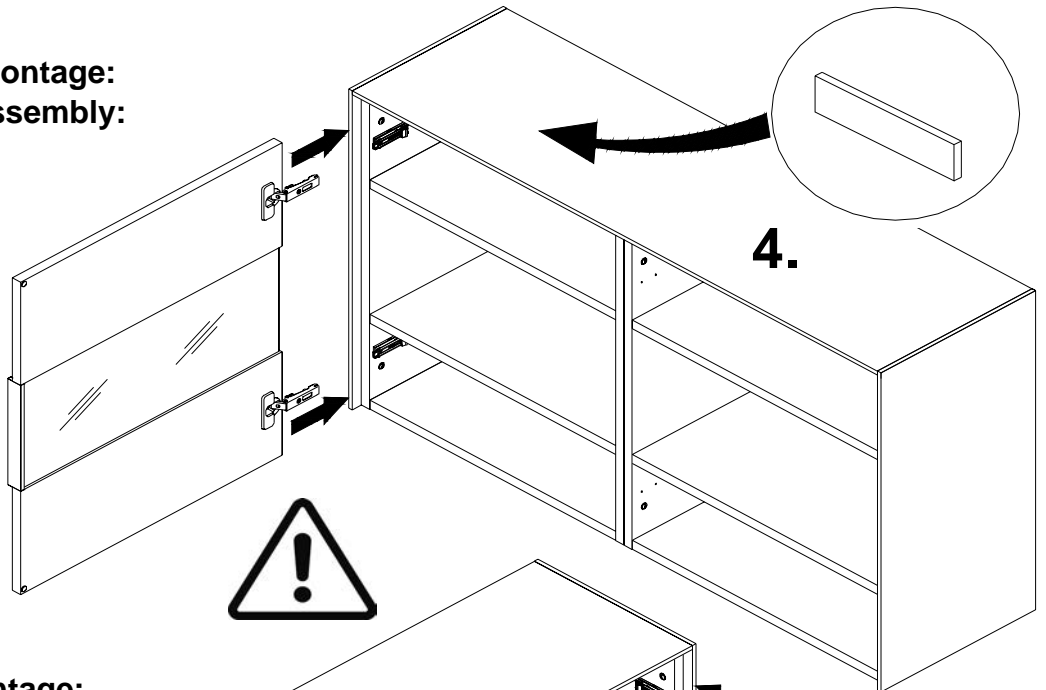

## Demontage: Dismounting:

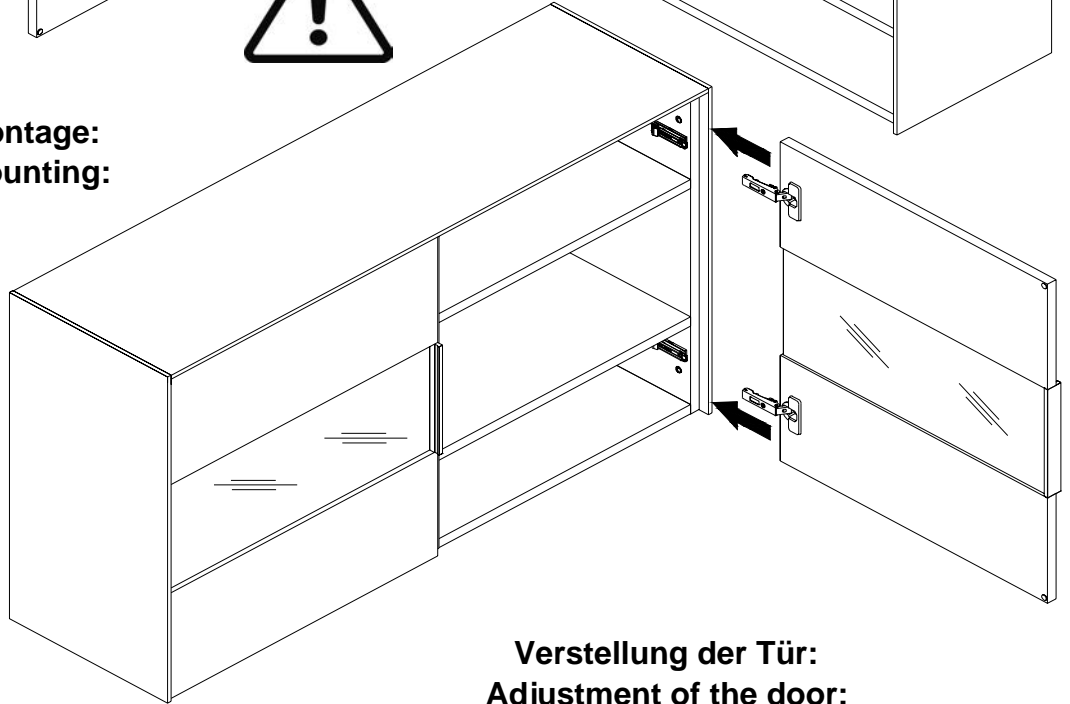

## Verstellung der Tür: Adjustment of the door:

### Height adjustment:

Eine Höhenverstellung der Tür von  $\pm 2$  mm ist mittels Exzenter möglich, ohne jegliche Schrauben lösen zu müssen.

# 2.

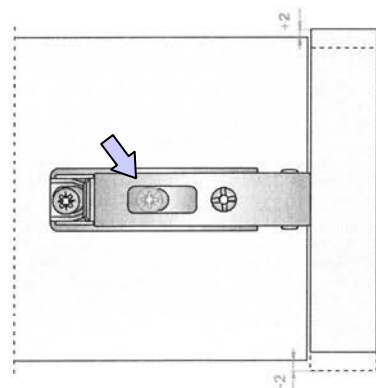
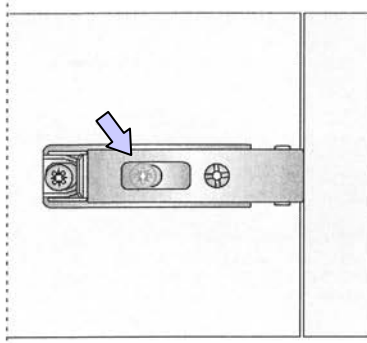
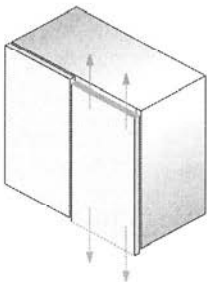

### Depth adjustment:

Eine Tiefenverstellung der Tür von  $-0,5$  mm bis zu  $+2,8$  mm ist mittels Exzenter möglich, ohne jegliche Schrauben lösen zu müssen.

# 3.

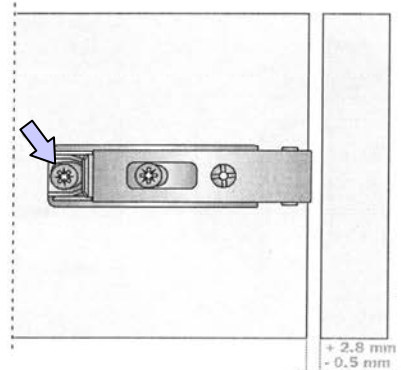
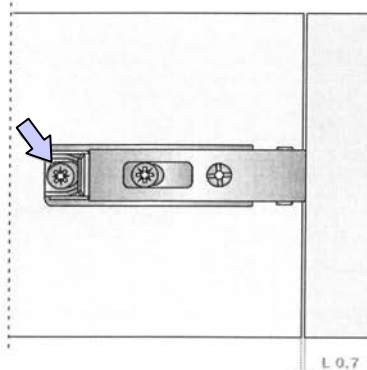
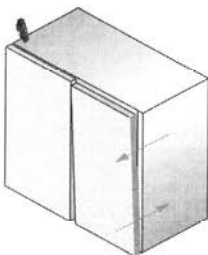





# Musterring

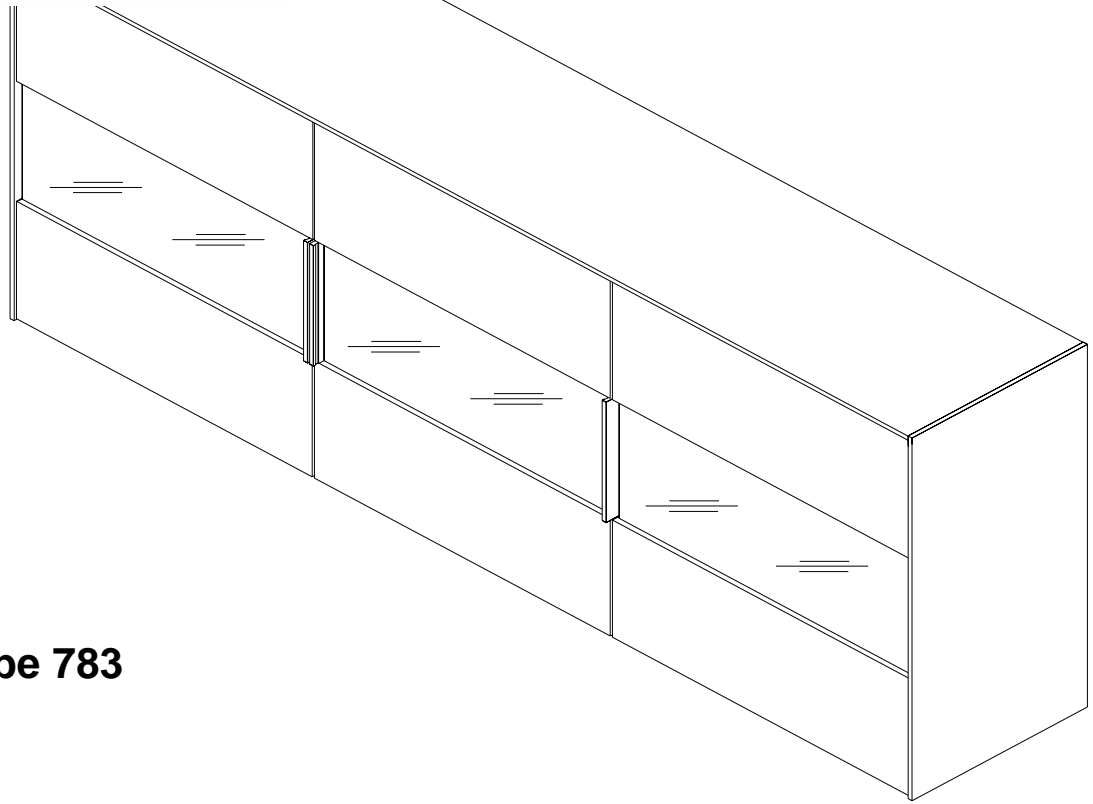

**Type 783**

Sehr geehrte Kundin, sehr geehrter Kunde,

Das beigefügte Wandbefestigungsmaterial (Dübel und Schrauben) eignet sich nur für festes Mauerwerk (z.B. Beton- oder Ziegelwände). Für andere Wandaufbauten sind eventuell Spezialdübel und andere Schrauben notwendig. Ziehen Sie gegebenenfalls eine Fachkraft zurate. Technische Änderungen vorbehalten.

Dear customer,

the provided mounting material (dowels and screws) can only be used with solid masonry (e.g. concrete or brick walls). For other wall constructions special dowels and screws are needed. Please consider an expert in these cases. Leaving technical changes.

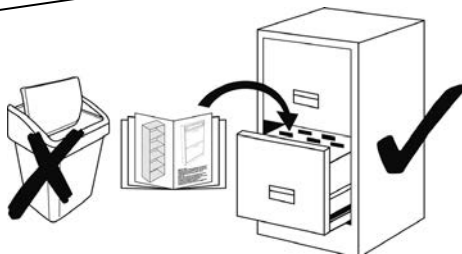
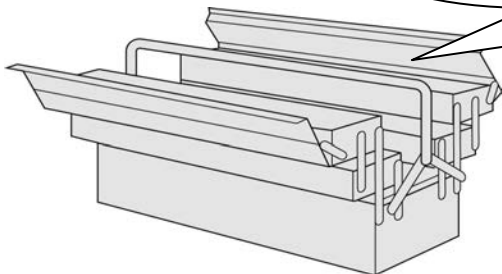
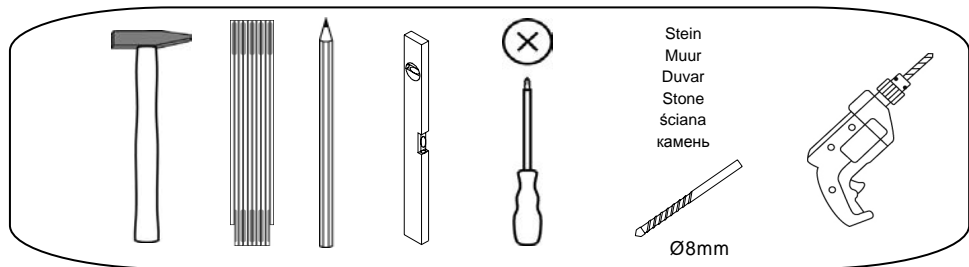
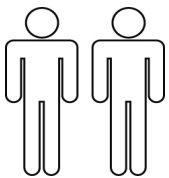

# Type 783

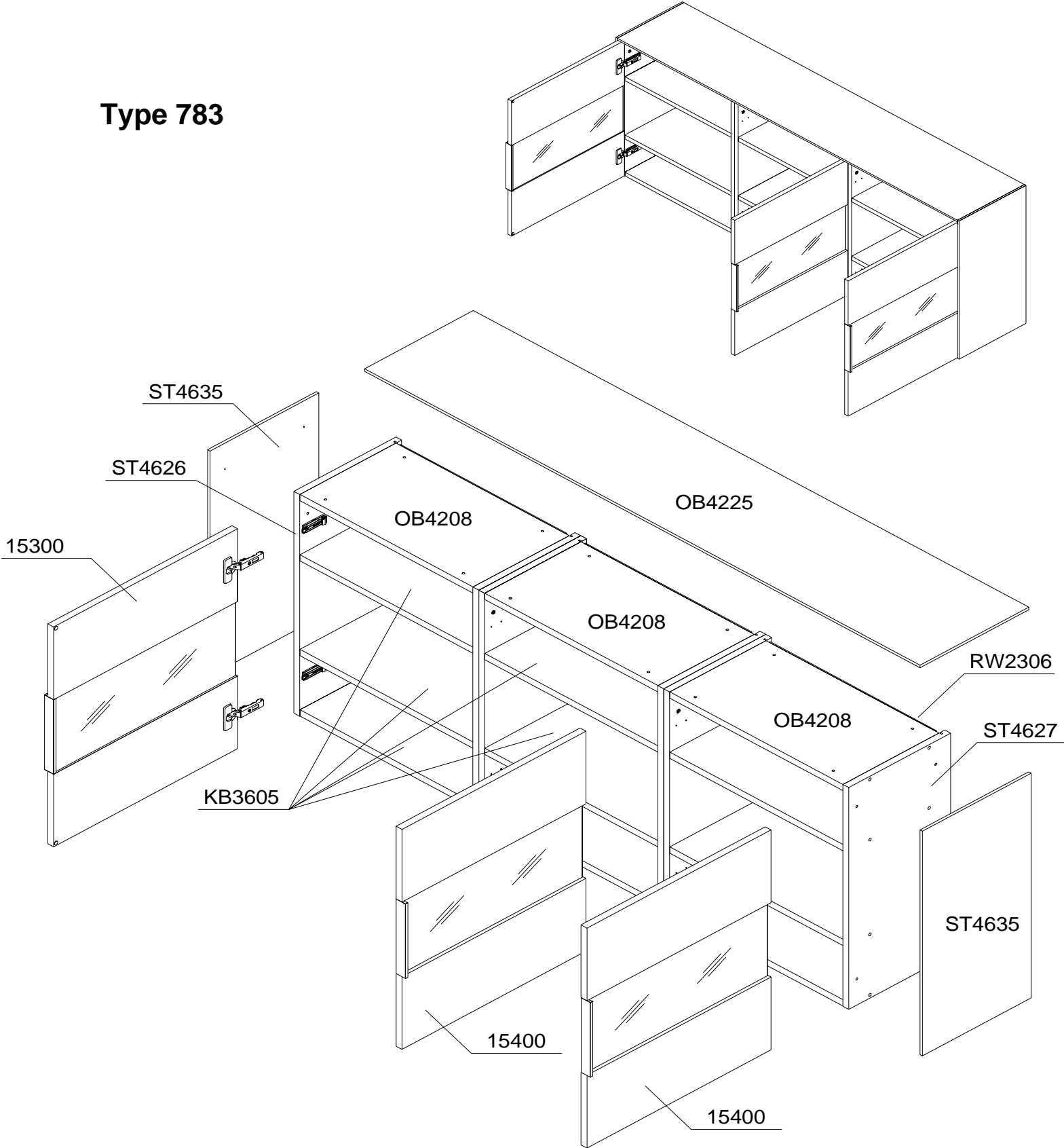

## Beschlagteile Typ 783

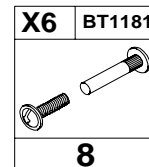
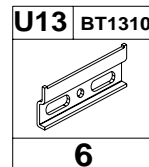
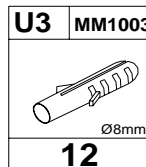
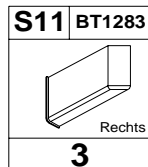
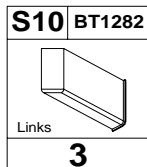
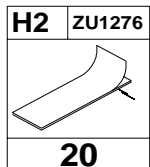

Demontage:  
Dismounting:



1.A.

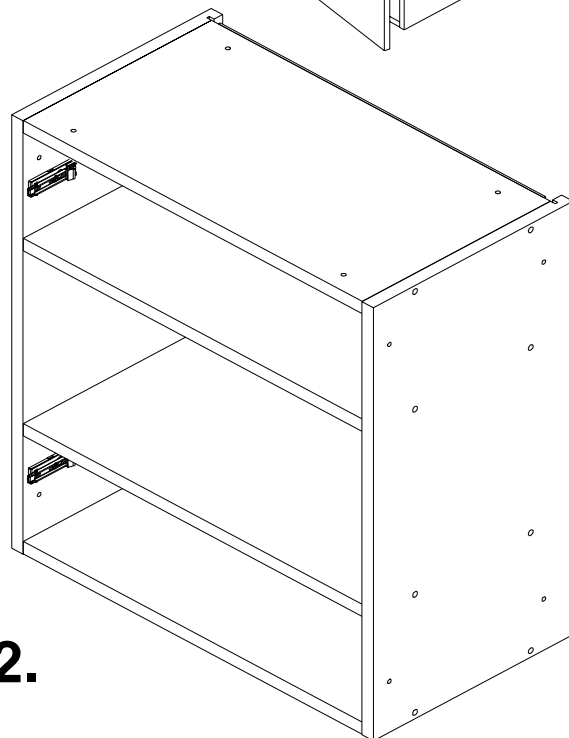
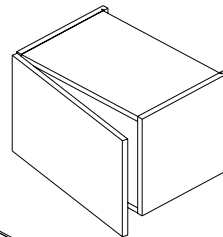
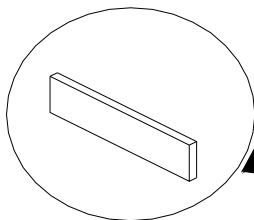

B.

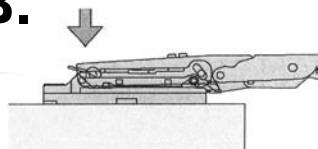

15300

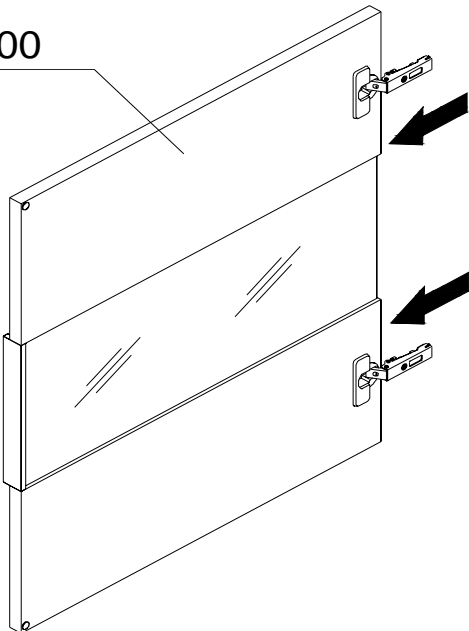

2.

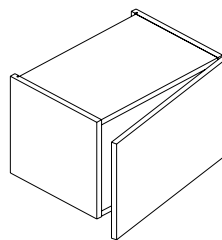

2 x

Das Lösen des Bandarmes von der Montage  
Druck auf die beiden mit Pfeil bezeichneten

C.

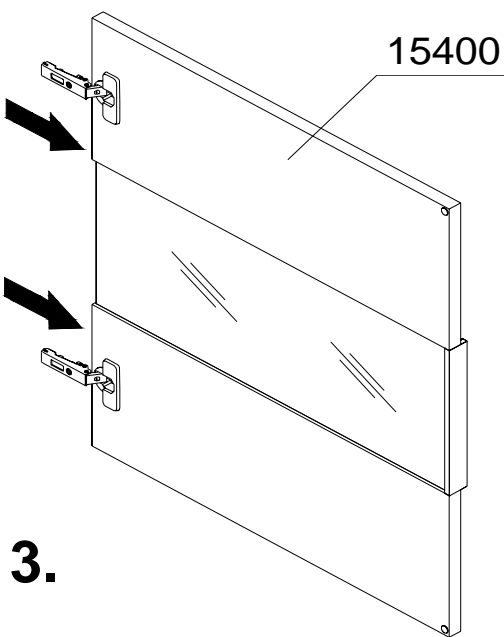
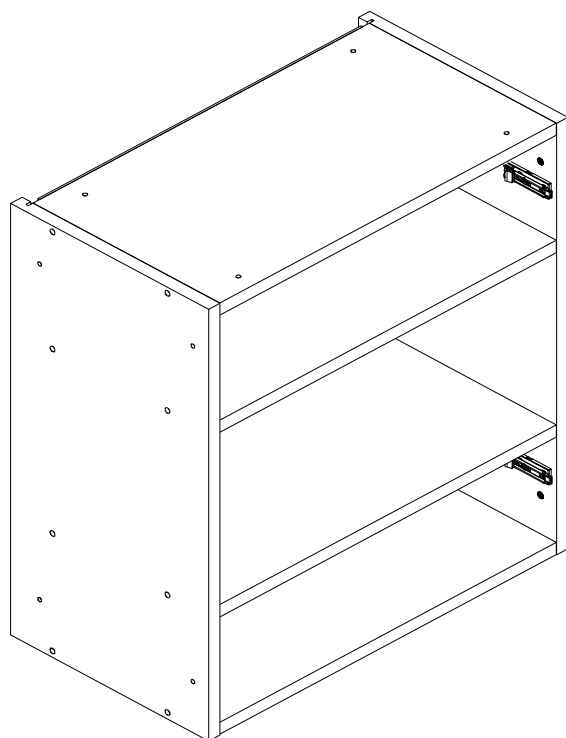
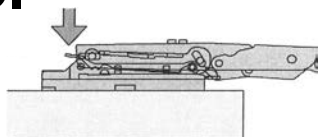

15400

3.

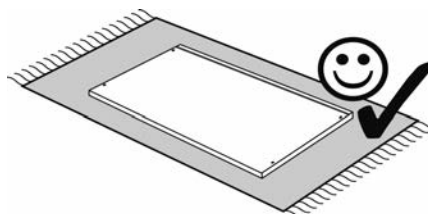
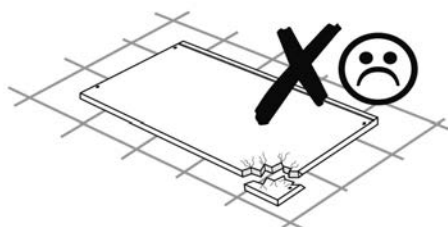

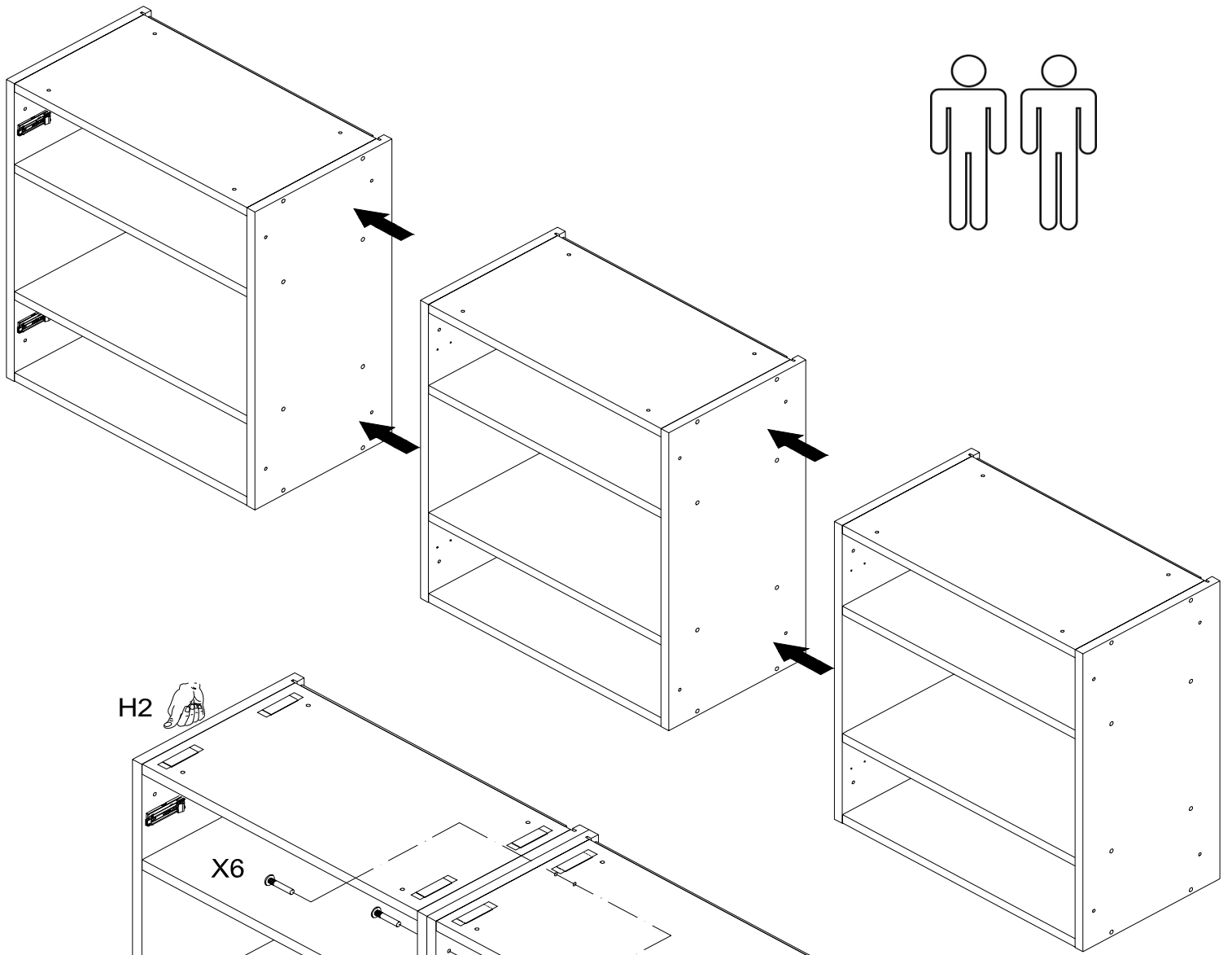

H2 

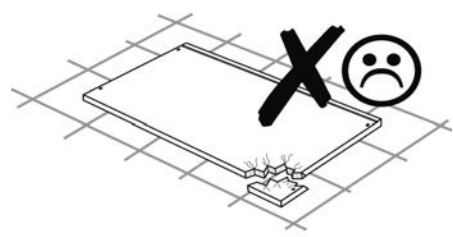
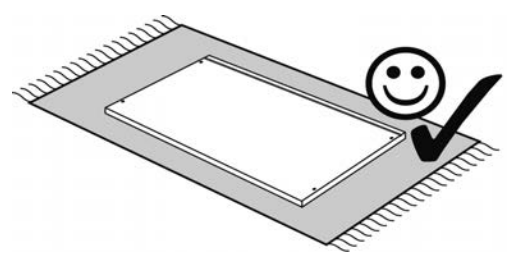
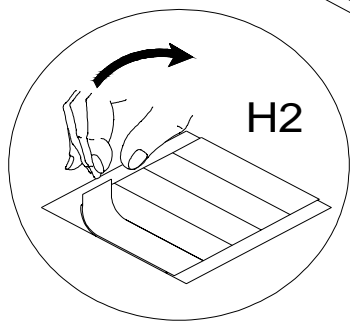
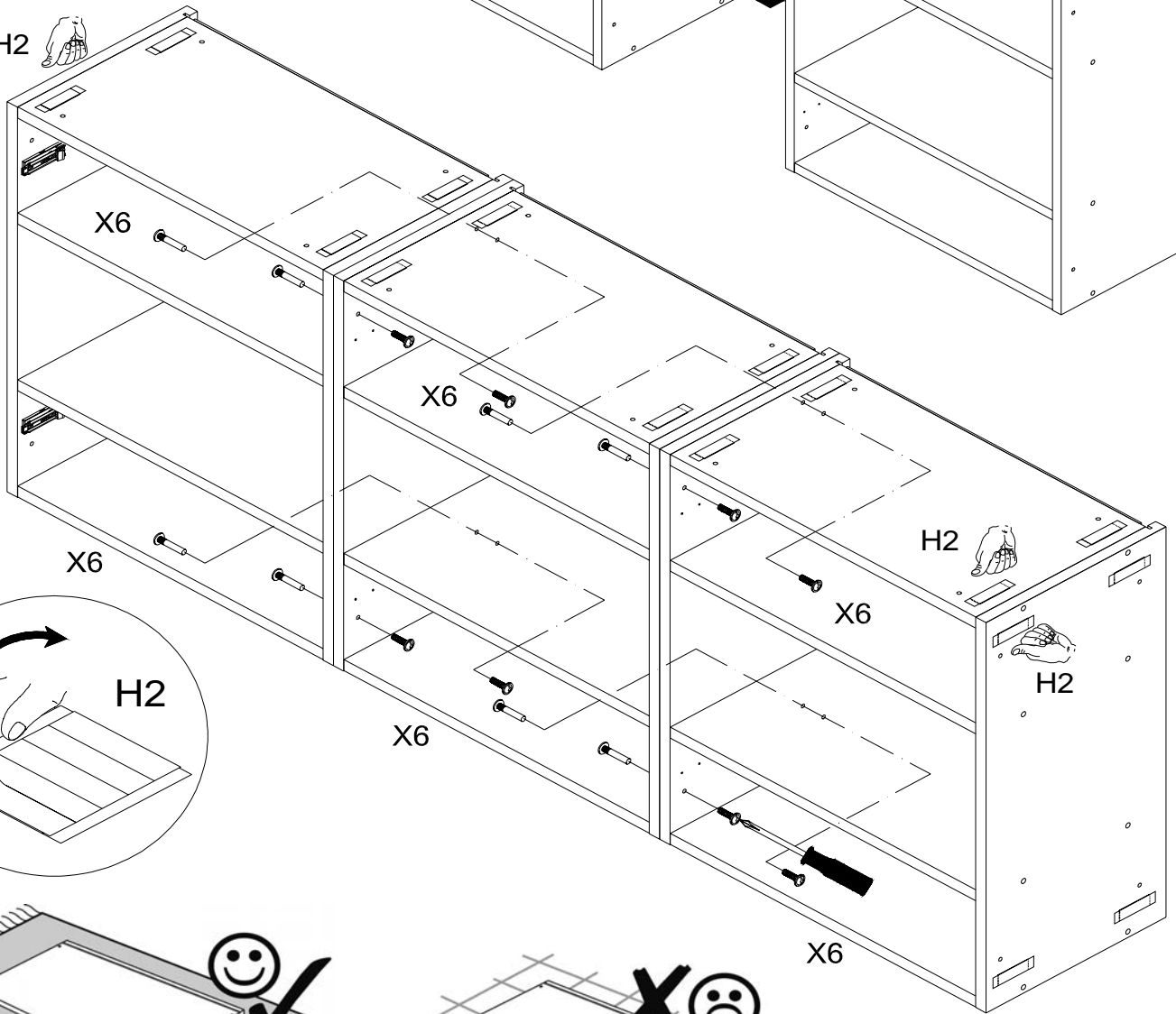

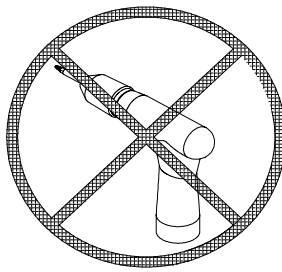

Die Schrauben zur Befestigung der Seiten und Böden nur mit einem Handschraubendreher anziehen.

Keinen Elektro- oder Akkuschauber verwenden.

Only use a hand screwdriver to attach the screws. Do not use an electric or cordless screwdriver.

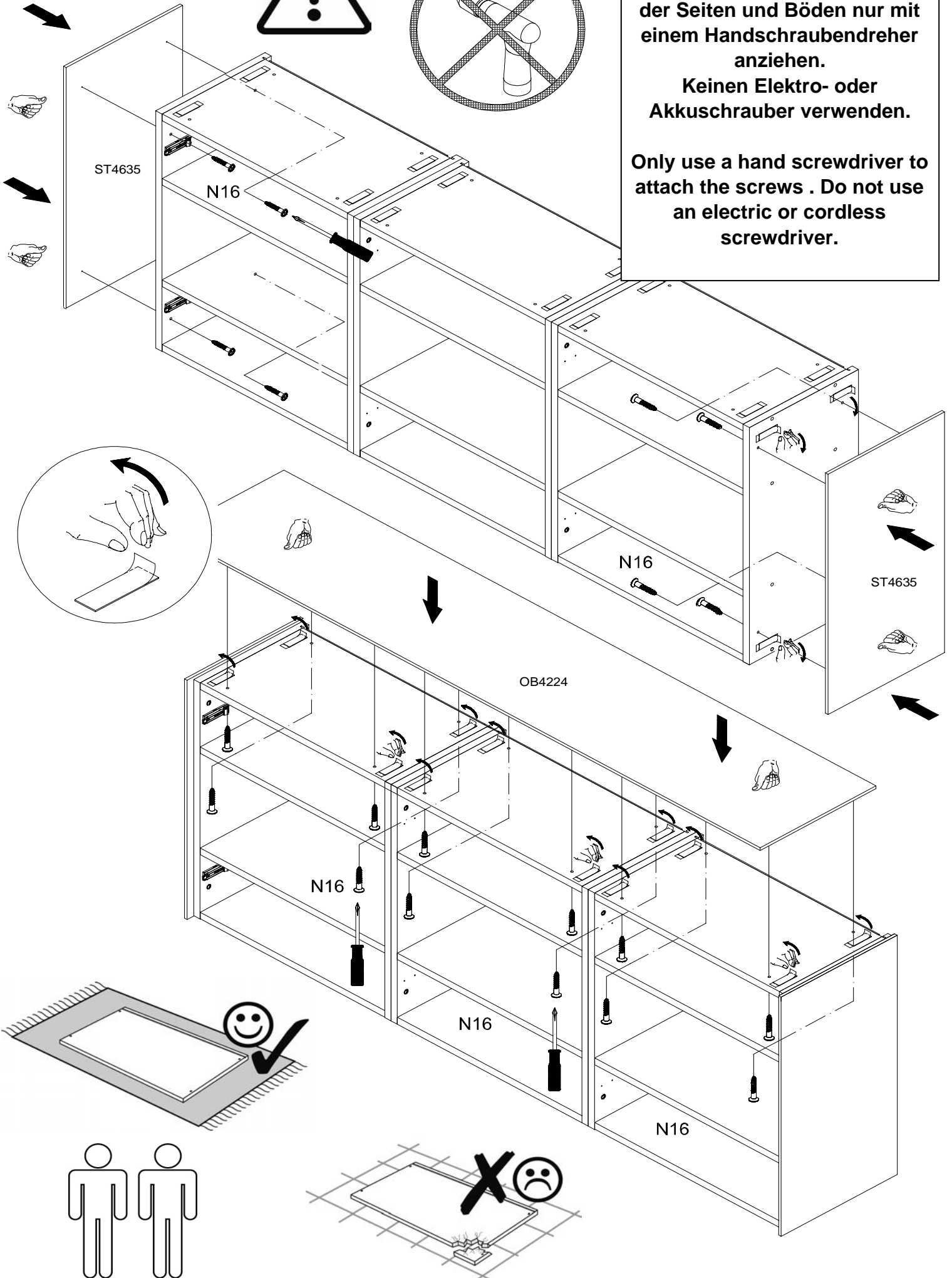

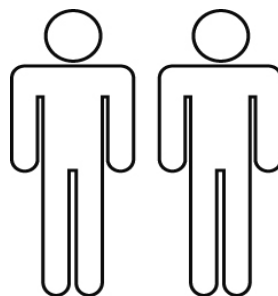
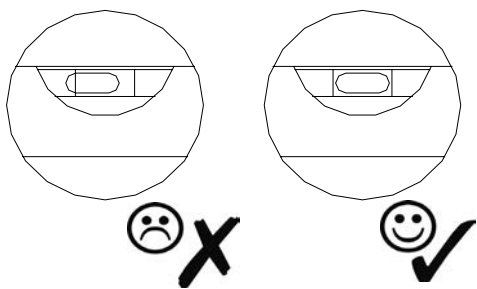
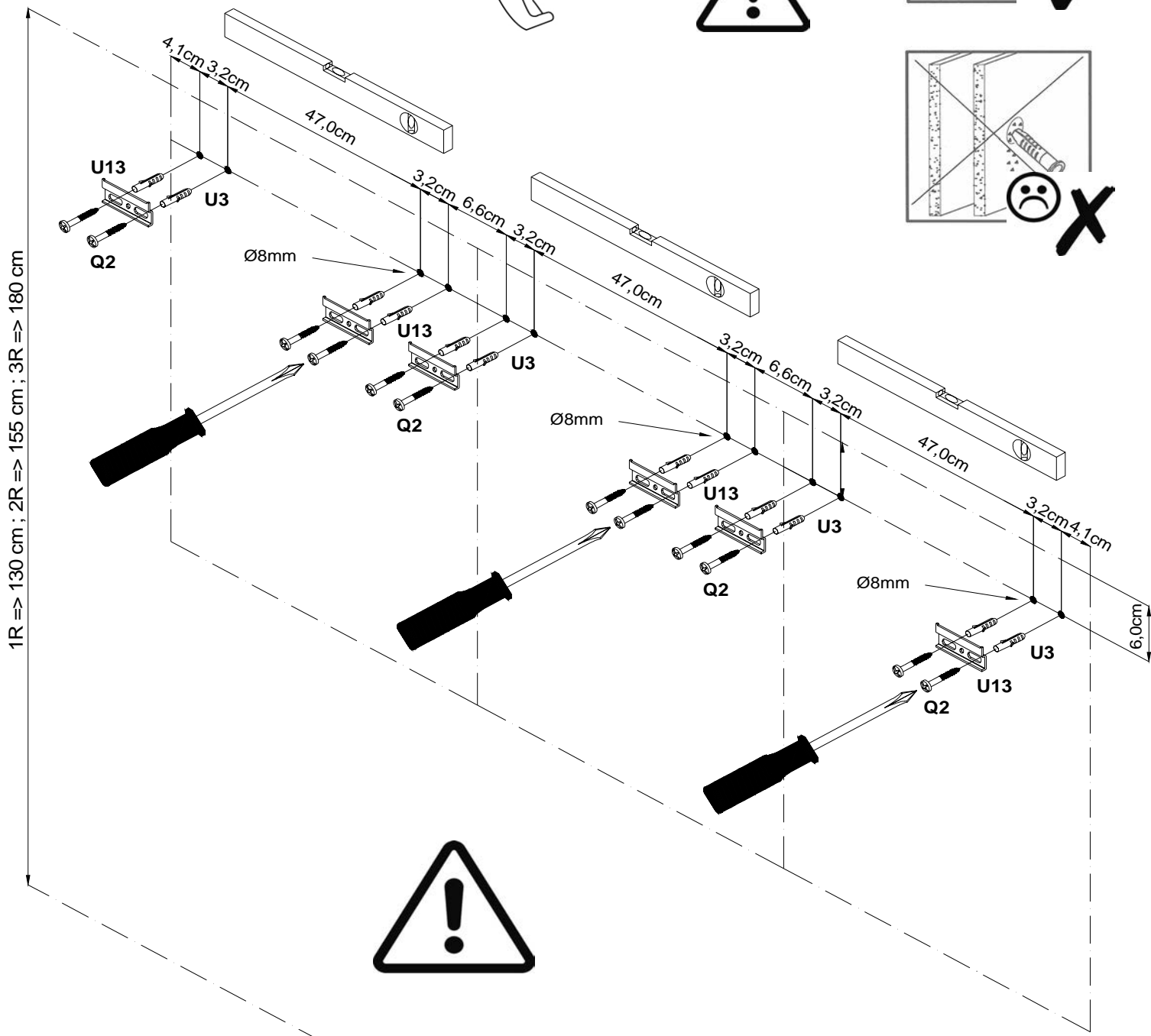
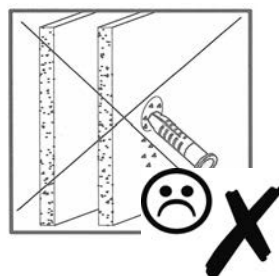
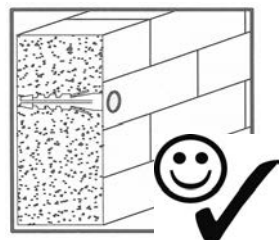
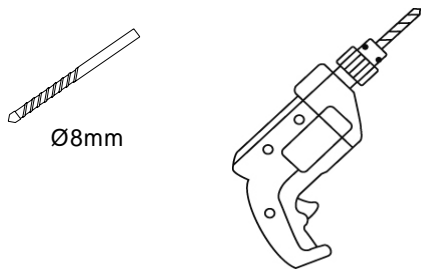

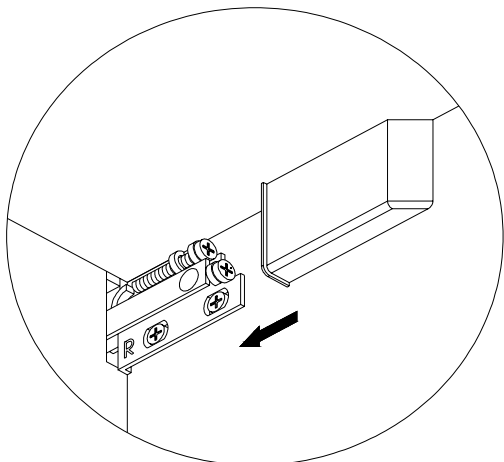
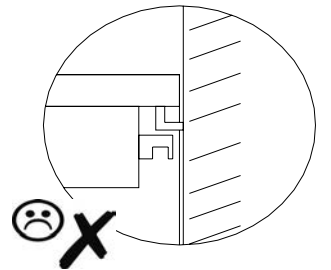
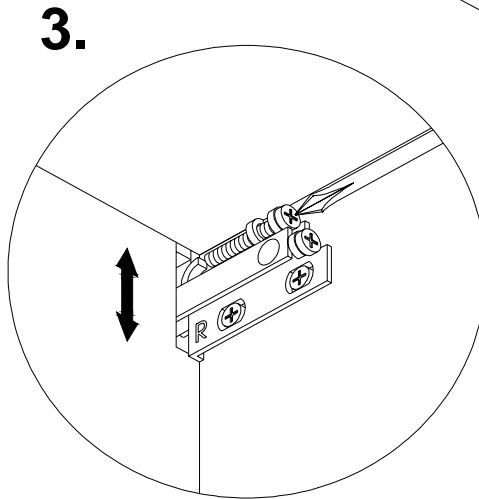
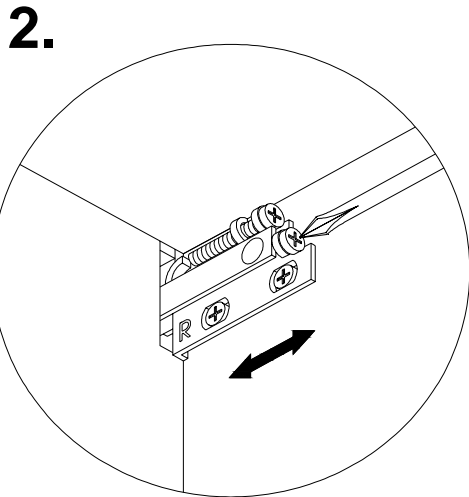
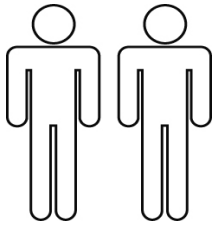
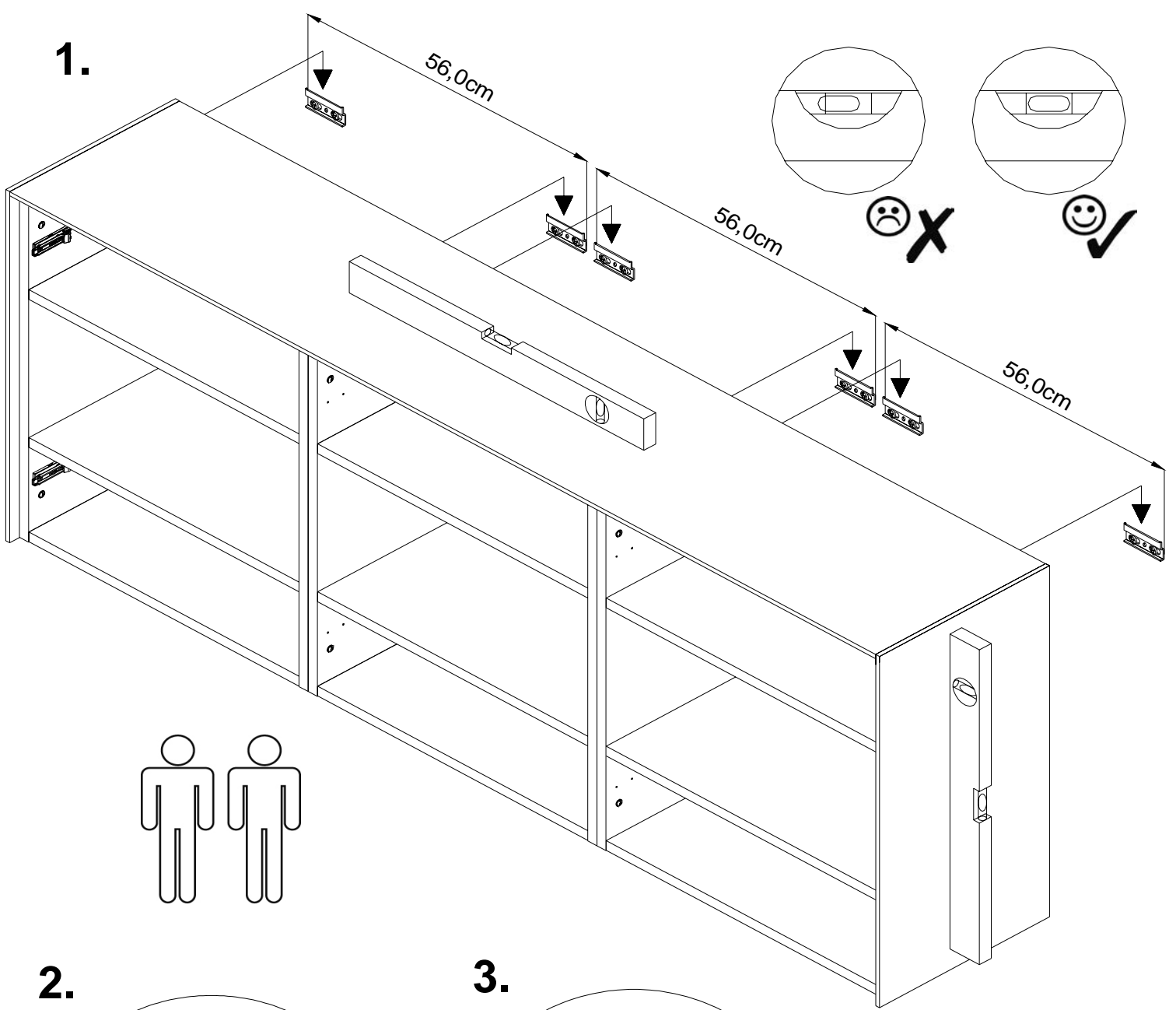

**4.**

**Ausrichten des Hängeschranks durch die Stellschrauben am Aufhängebeslag:**  
**Adjustment of the wall cupboard with set-screws on the fitting:**

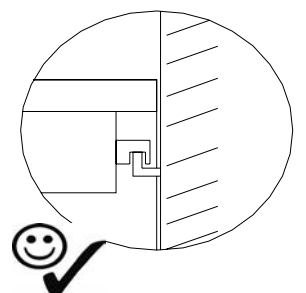

Die beiden mit Pfeil bezeichneten Punkte ir

# 1.A.

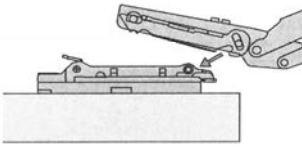

Eine leichte Drehung ausführen

# B.

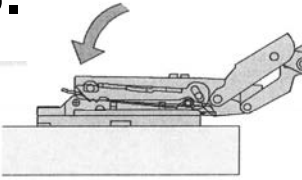

und leicht andrücken.

# C.

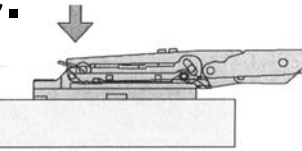

Das Lösen des Bandarmes von der Montage  
Druck auf die beiden mit Pfeil bezeichneten

# D.

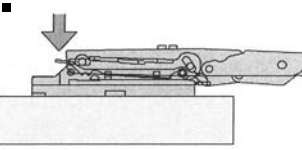

## Montage: Assembly:

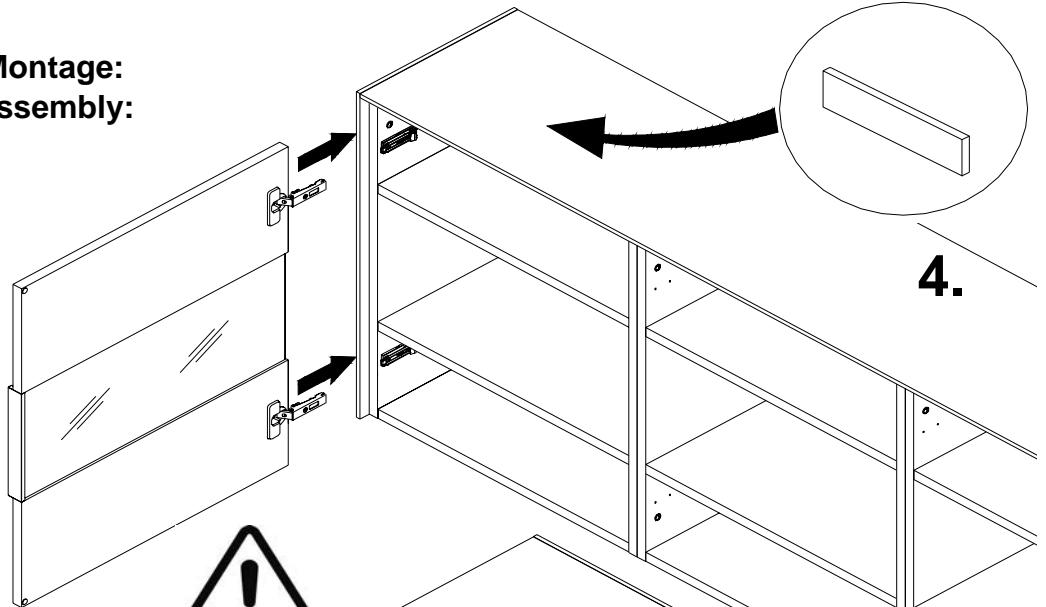

4.

## Demontage: Dismounting:

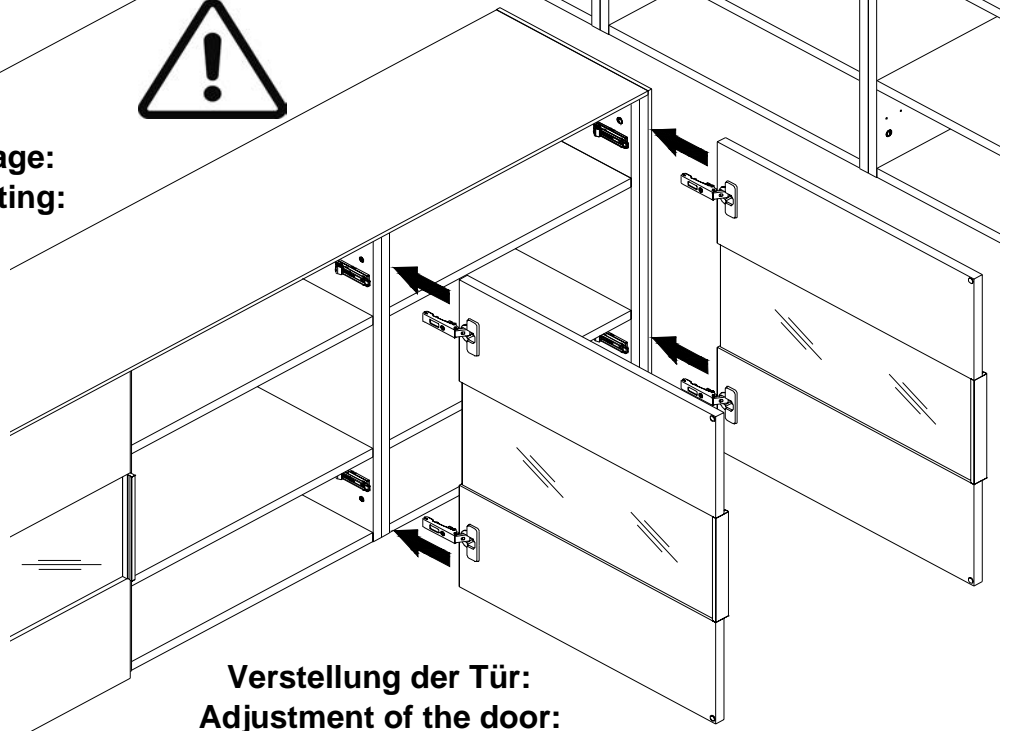

## Verstellung der Tür: Adjustment of the door:

### Height adjustment:

Eine Höhenverstellung der Tür von  $\pm 2$  mm ist mittels Exzenter möglich, ohne jegliche Schrauben lösen zu müssen.

# 2.

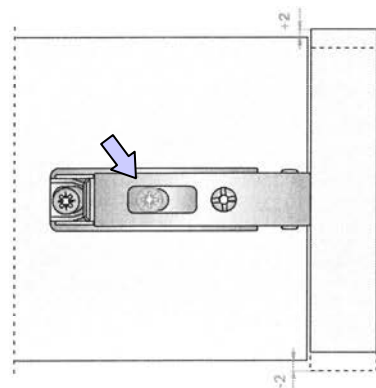
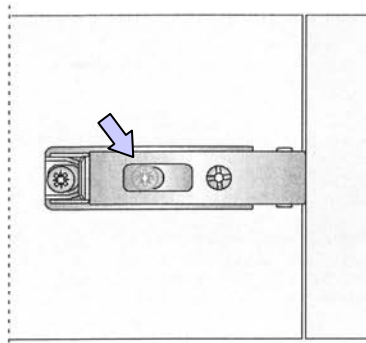
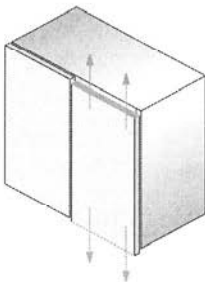

### Depth adjustment:

Eine Tiefenverstellung der Tür von -0,5 mm bis zu +2,8 mm ist mittels Exzenter möglich, ohne jegliche Schrauben lösen zu müssen.

# 3.

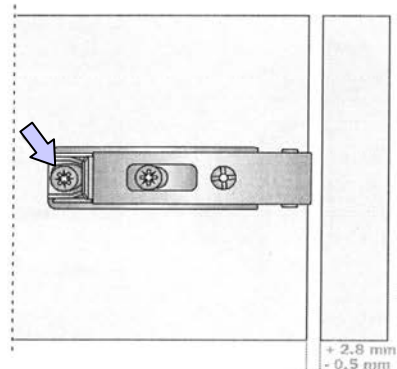
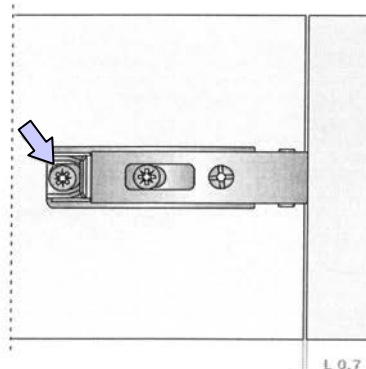
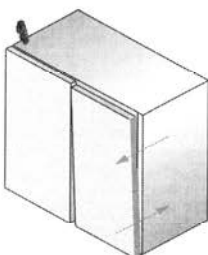



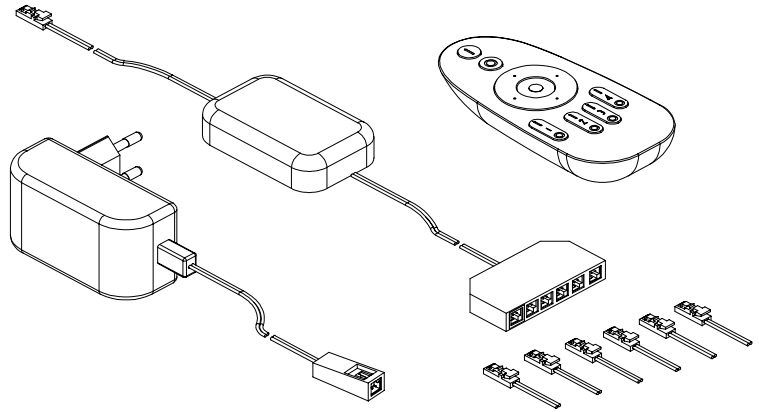

Montage:  
Assembly:

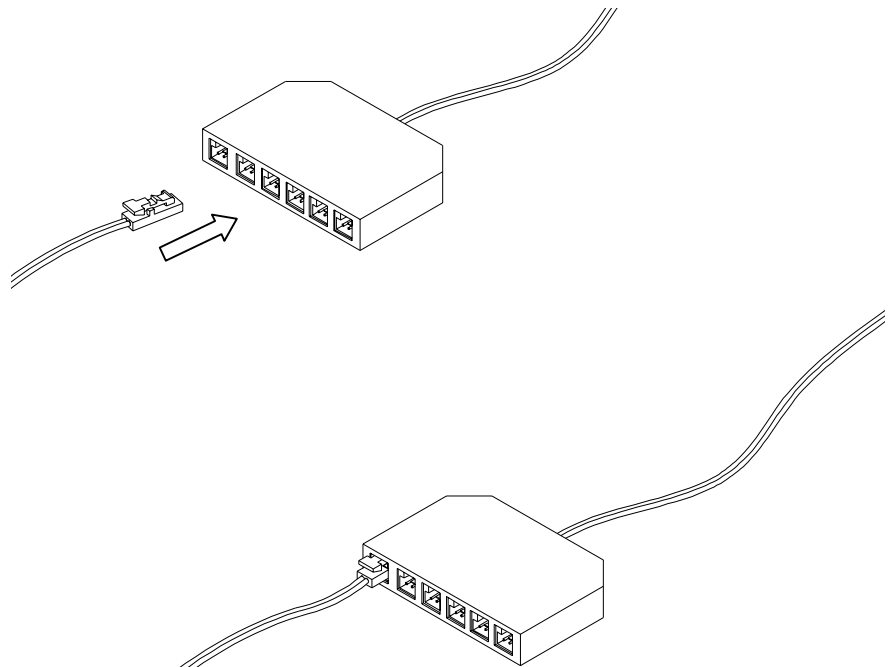
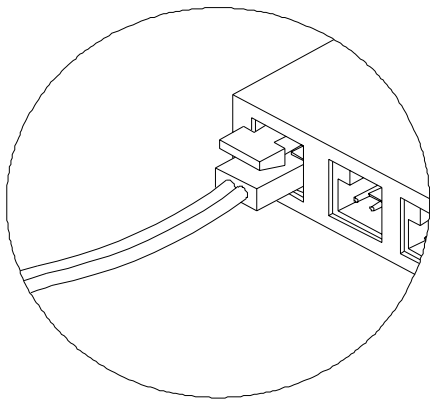
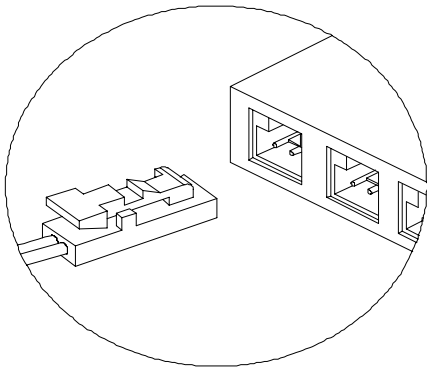

1. Schutzfolie der Batterie entfernen  
=> Inbetriebnahme !

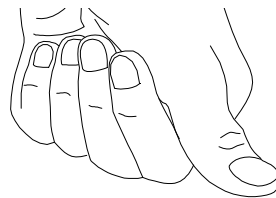

3. langer Tastendruck  
Ring oben / unten  
=> dimmen !

2. kurzer Tastendruck  
I / O => on / off !

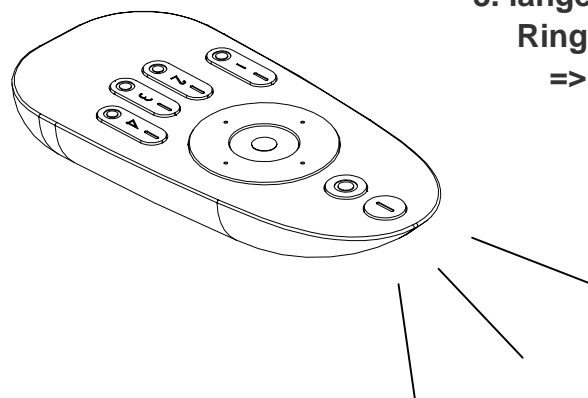

Herzlichen Glückwunsch! Sie haben sich für ein qualitativ hochwertiges, energiesparendes Beleuchtungssystem entschieden. Bei richtiger Handhabung werden Sie sehr lange Freude daran haben. Diese Anleitung bitte gut aufbewahren!



### !ACHTUNG!

Um die reibungslose Funktionsfähigkeit sicher zu stellen, wickeln Sie bitte vor Montage und Inbetriebnahme beide Zuleitungskabel vollständig ab.

### PROGRAMMIEREN

Mit diesem Steuerungssystem haben sie die Möglichkeit, Ihre Beleuchtung in bis zu 4 Kanälen zu gruppieren und zu schalten.

Um die Steuerung zu programmieren, trennen Sie bitte die Beleuchtung komplett vom Stromnetz. Warten Sie ein paar Sekunden, bis alle Geräte frei von Reststrom sind, dann schließen Sie die Beleuchtung wieder an das Stromnetz an.

Innerhalb von 3 Sekunden nach Anschließen der Beleuchtung an das Stromnetz, drücken Sie die gewünschte Kanaltaste ein Mal. Die angeschlossene Leuchte blinkt mehrmals schnell hintereinander und ist jetzt programmiert und einsatzbereit.

Auf diese Weise können Sie jede weitere Leuchte einem der 4 Kanäle zuordnen.

### TECHNISCHE ANGABEN

Typ Fernbedienung:	Vario
Spannung:	12 VDC
Schaltleistung:	60W
Primärkabel:	2m
Sekundärkabel:	2m

### EIN- / AUS

Drücken Sie die ON-Taste ein Mal, um die Beleuchtung einzuschalten. Um die Beleuchtung auszuschalten, drücken Sie die OFF-Taste ein Mal.

**ACHTUNG:** Haben Sie mehrere Beleuchtungssysteme auf eine Fernbedienung programmiert, schalten Sie einzelne Beleuchtungsgruppen auch mit den Gruppentasten.

### DIMMEN

Mittels des Bedienungsrad lässt sich Ihre Beleuchtung bis auf 20% der Leuchtkraft runterdimmen.

Drücken Sie den unteren oder linken Teil des Bedienungsrad, dimmen Sie die Beleuchtung runter. Zum Hochdimmen der Beleuchtung drücken Sie den oberen oder rechten Teil des Bedienungsrad.

Um sofort die maximale Helligkeit zu erreichen, drücken Sie die ON-Taste für 2 Sekunden. Drücken Sie die OFF-Taste für 2 Sekunden, wird sofort die niedrigste Dimmstufe eingestellt. Diese eignet sich ideal als Nachtlicht.



# Q-Media



## Inhaltsverzeichnis High-/Sideboards Vitrinen & Zubehör



Übersicht der Highboards

Seite 65 bis Seite 75

Übersicht der Sideboards

Seite 76 bis Seite 84

Übersicht der Vitrinen

Seite 85 bis Seite 92

Übersicht der Tische

Seite 93 bis Seite 97

Übersicht der Regal-/Hängeböden

Seite 98 bis Seite 100

Übersicht zum Zubehör und Erweiterungen

ab Seite 101

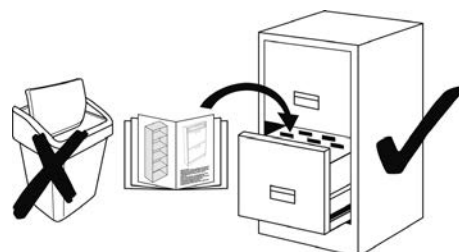
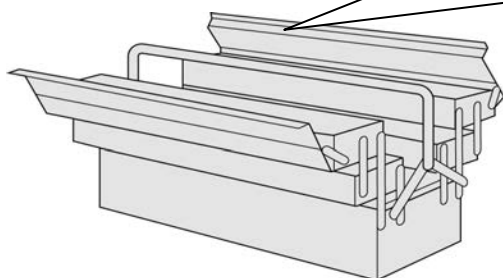
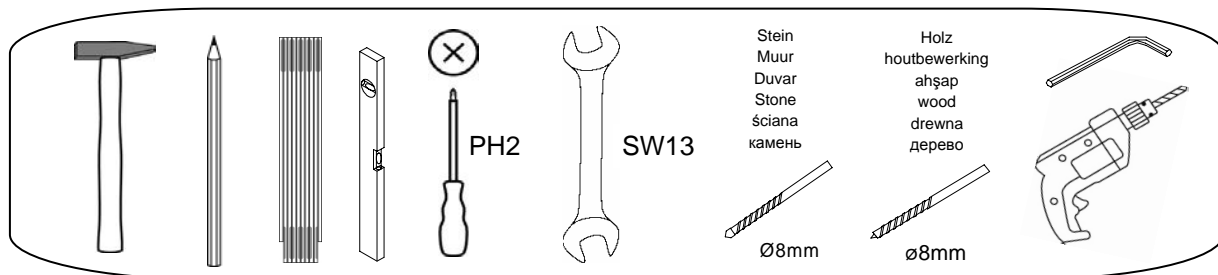
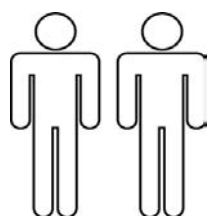

# Q-Media

## Übersicht Highboards



**Musterring**

**Type 734**

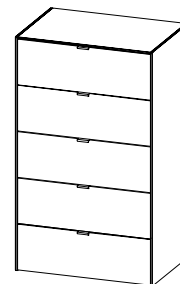

**Type 710**

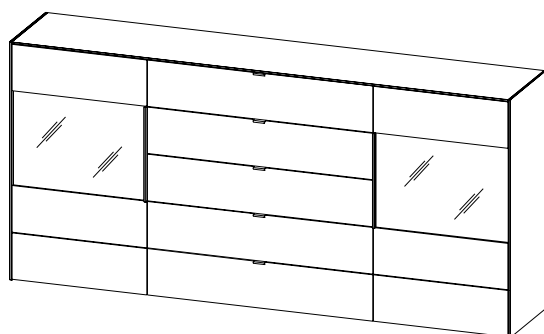

**Type 740**

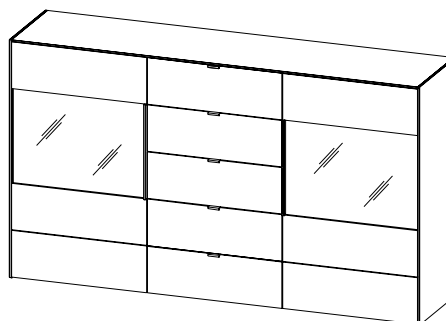

**Type 742**

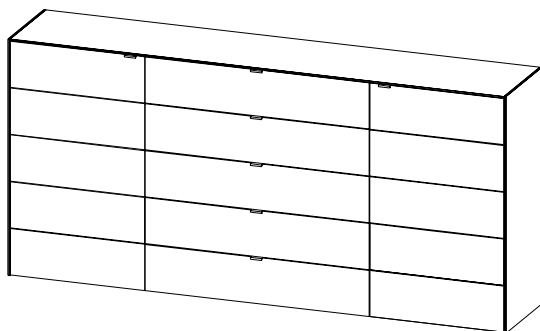

**Type 743**

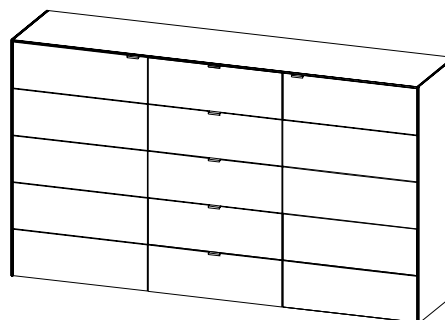

**Type 741**

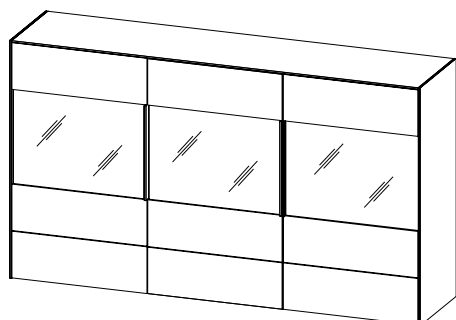

**Type 744**

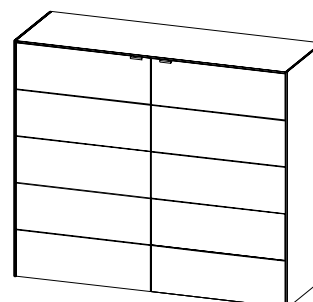



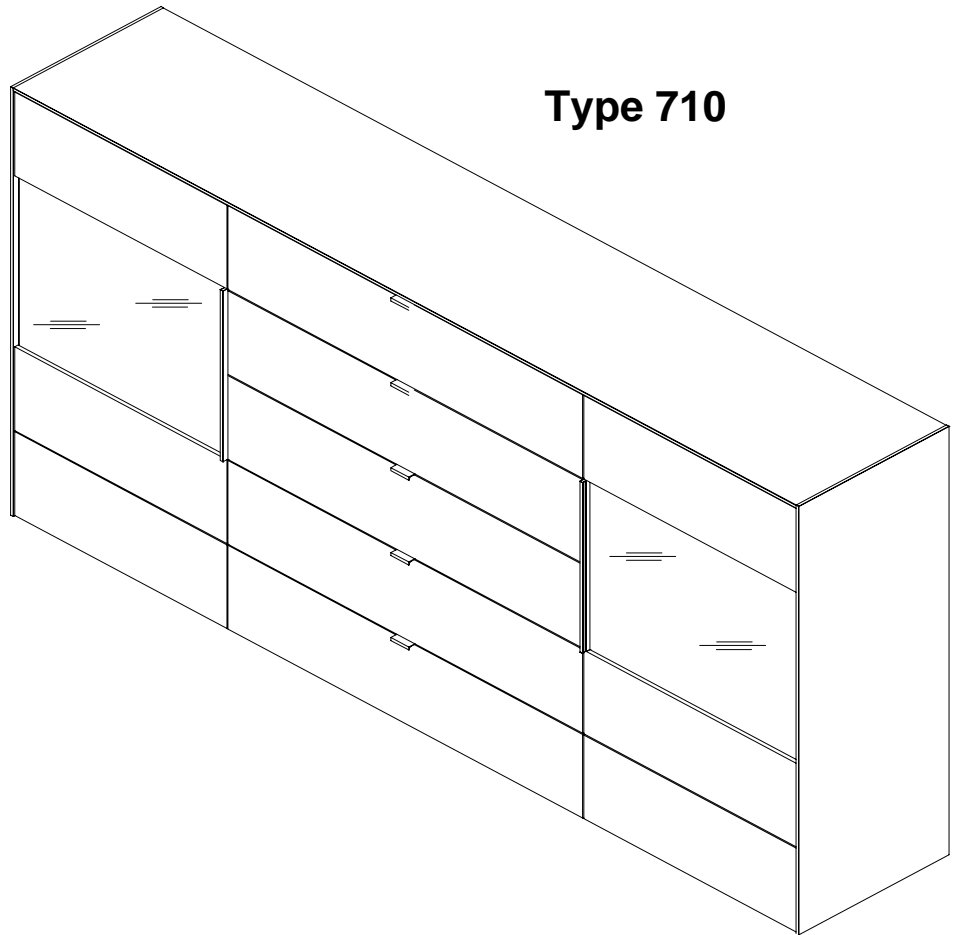

## Musterring

Beispiel  
exampel

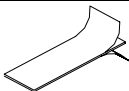
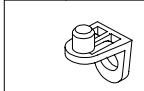
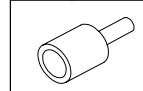
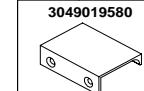

Type 710

### Beschlagteile Typ 710

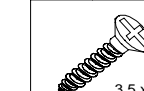
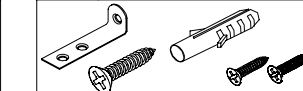
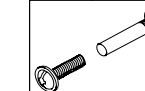
<b>H2</b> ZU1276  <b>36</b>	<b>D14</b> BT1395  <b>8</b>	<b>D15</b> BT1362  <b>8</b>	<b>M53</b> 3049019580  <b>5</b>	<b>N16</b> MM1183  4,0 x 25 ohne Spitze <b>36</b>	<b>P11</b> MM1148  3,5 x 17 <b>18</b>	<b>U5</b> MM1006  <b>3 Set</b>	<b>X6</b> BT1181  <b>16</b>
---	--	--	---	--	--	---	--

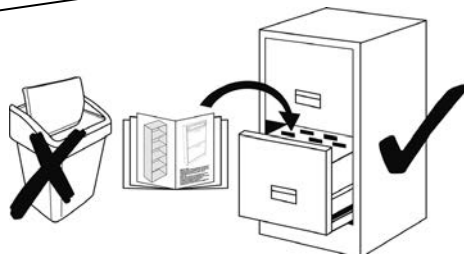
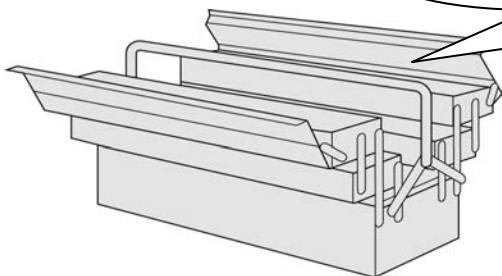
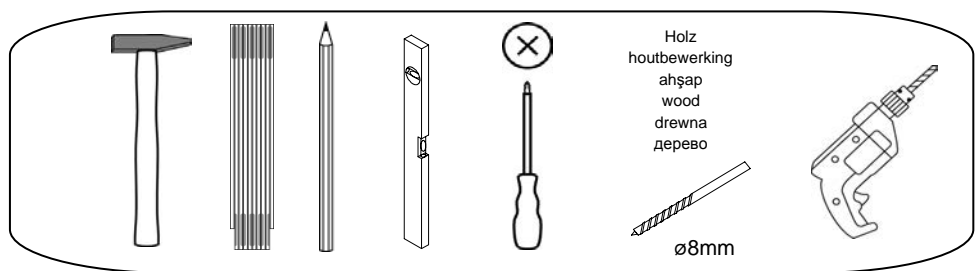
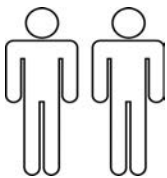

# Type 710 bestehend aus:

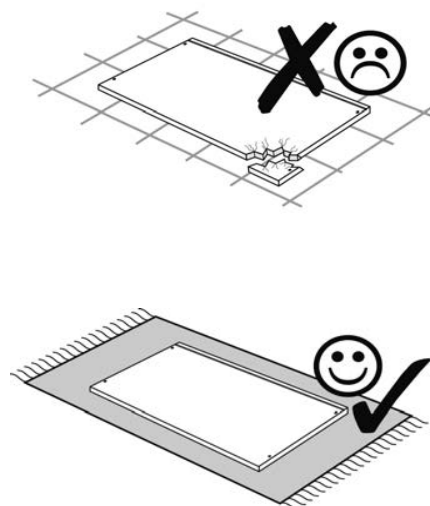
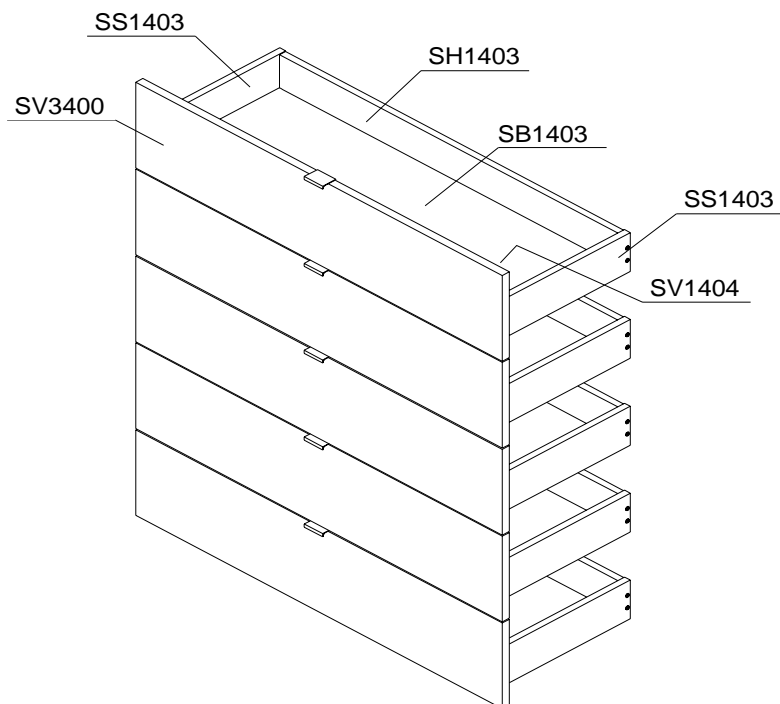
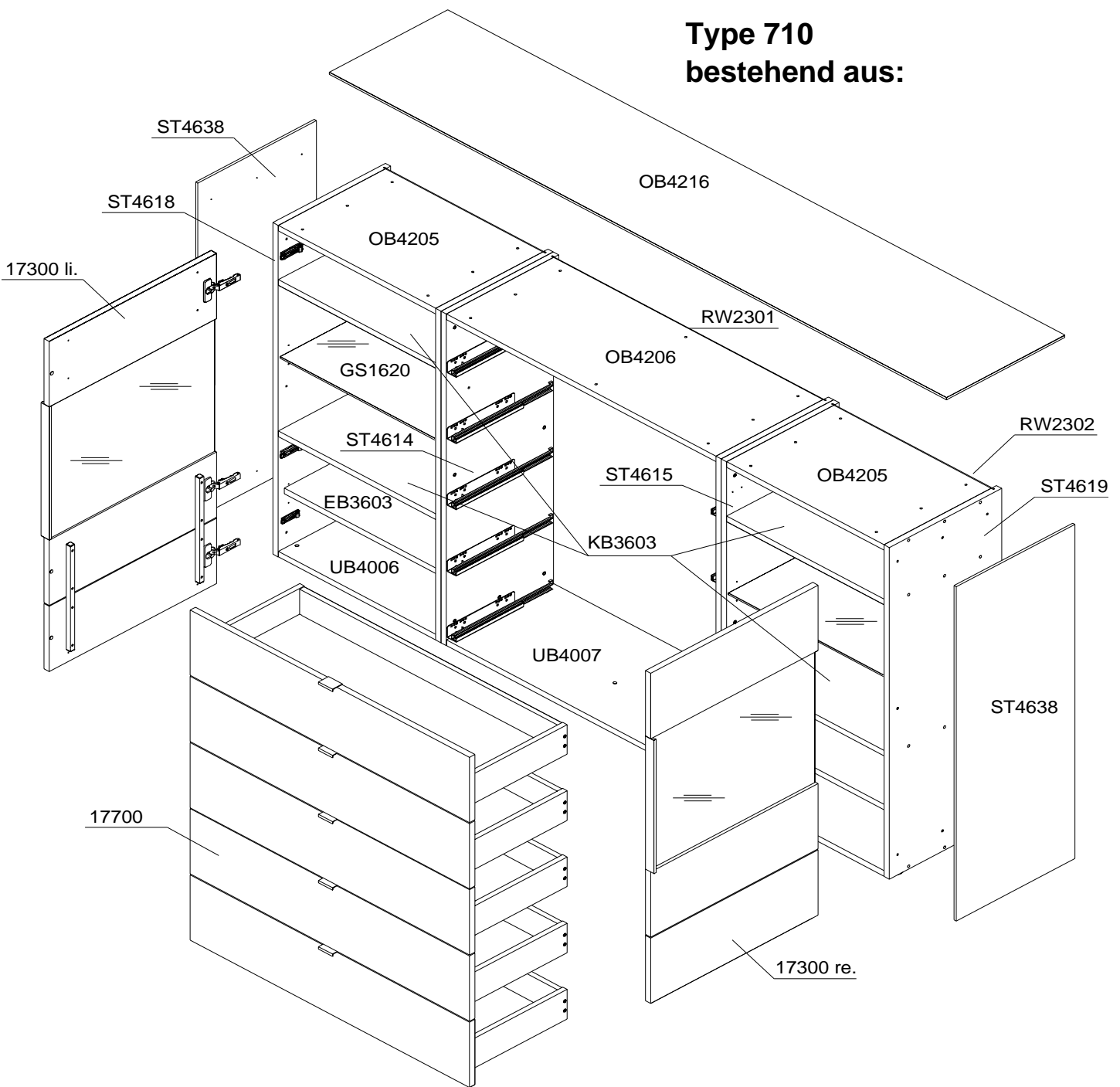

**Demontage:  
Dismounting:**

**1.A.**

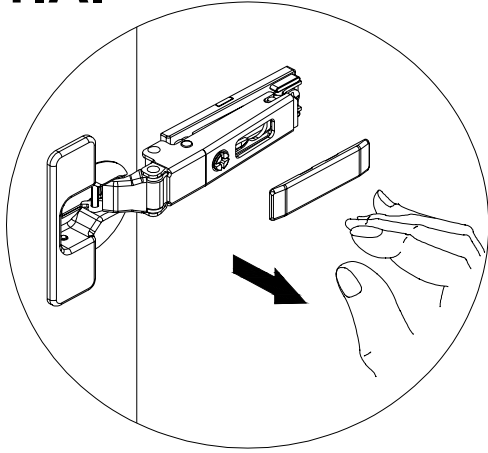

**B.**

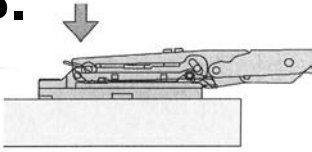

Das Lösen des Bandarmes von der Montage  
Druck auf die beiden mit Pfeil bezeichneten

**C.**

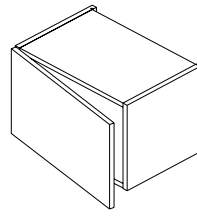
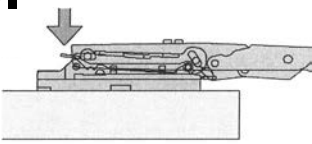

+

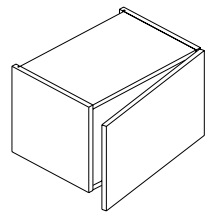

**2.**

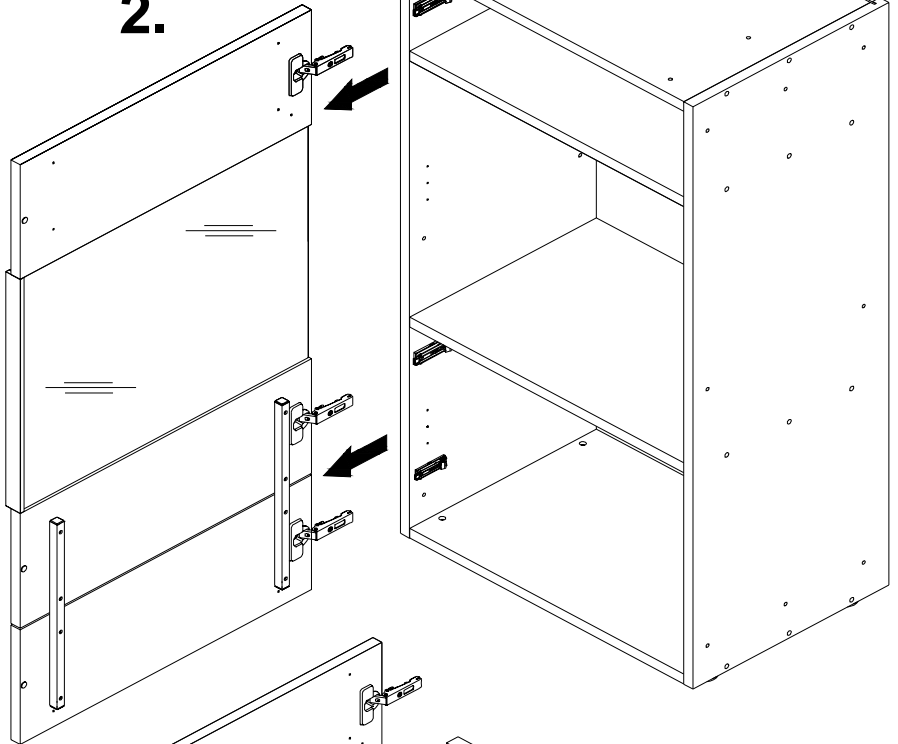

**3.**

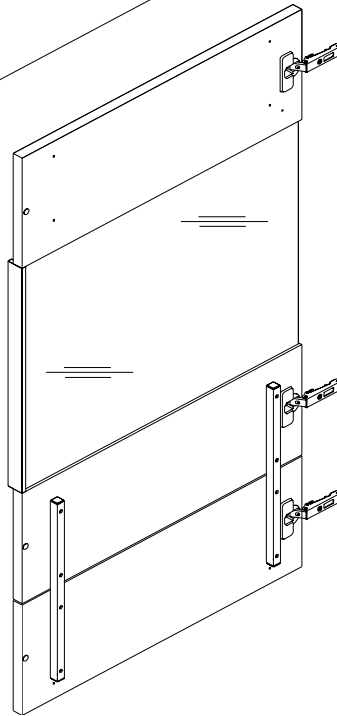
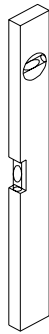
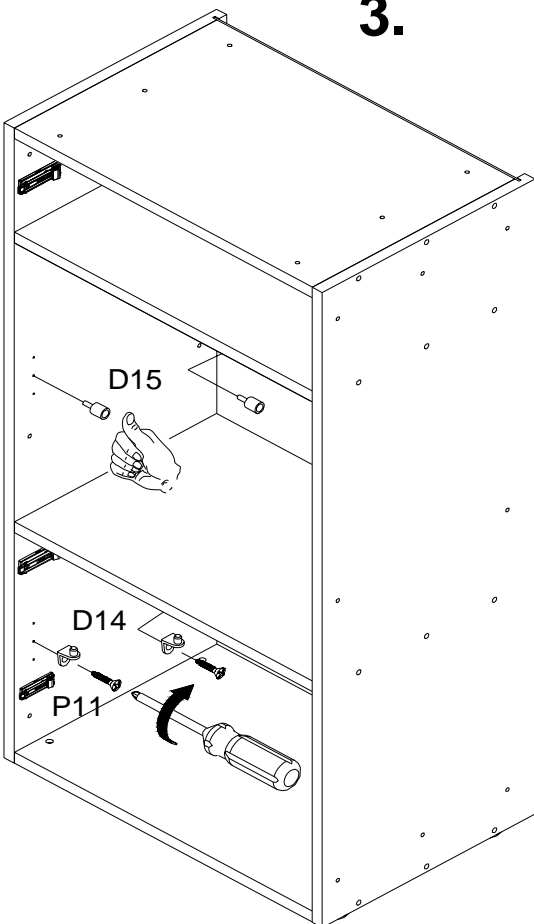

**Achtung Bruchgefahr:  
Immer vor Durchbiegung  
schützen !**

**Always protect from  
bending: Warning Danger  
of breakage !**

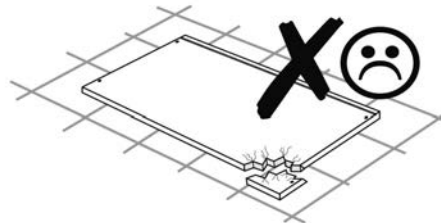
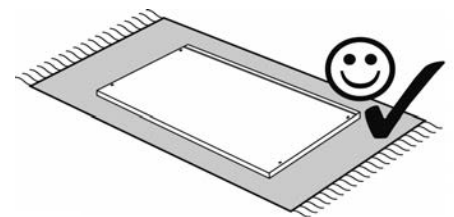
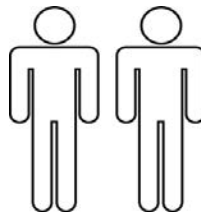

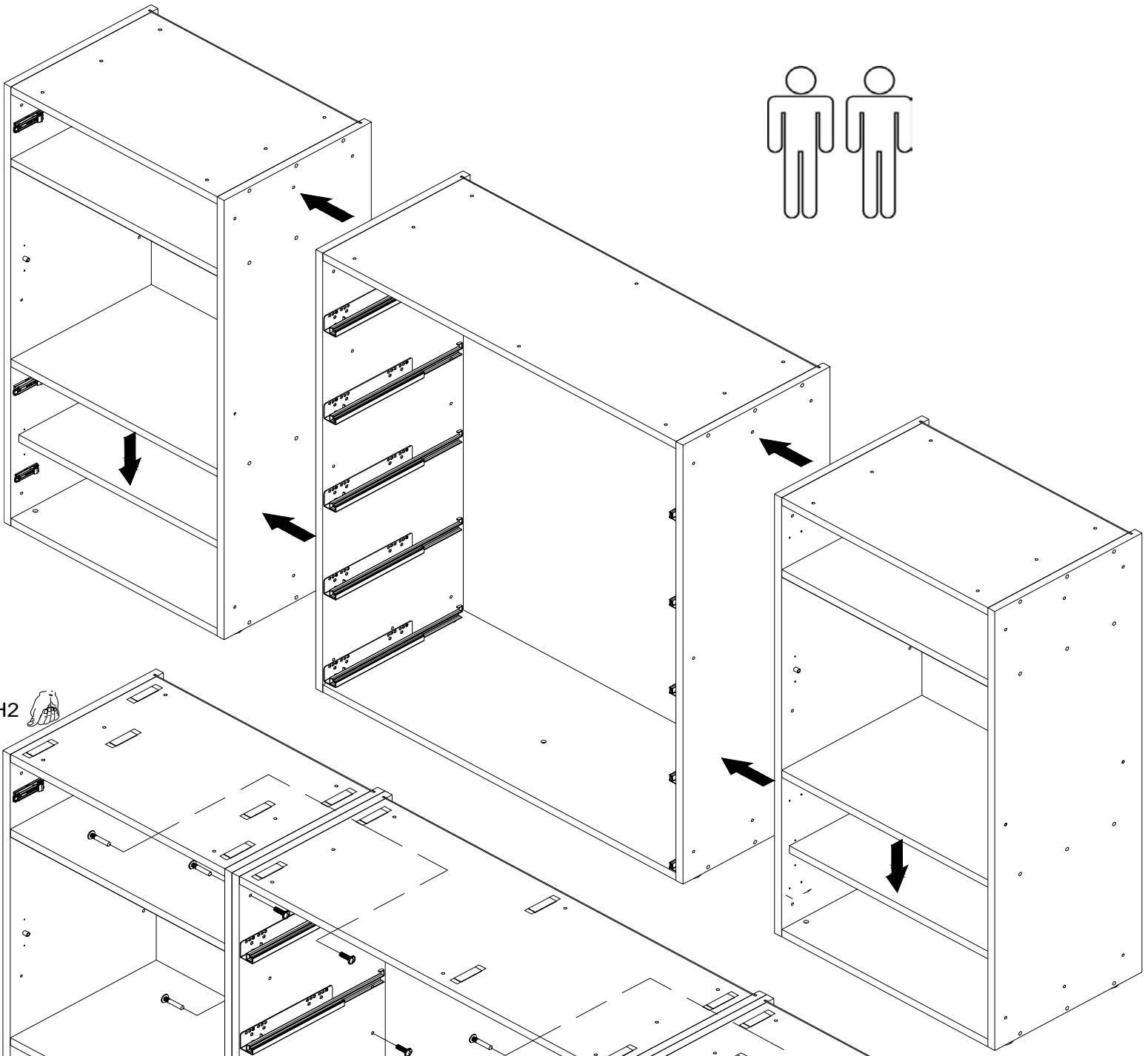
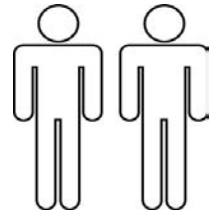

H2

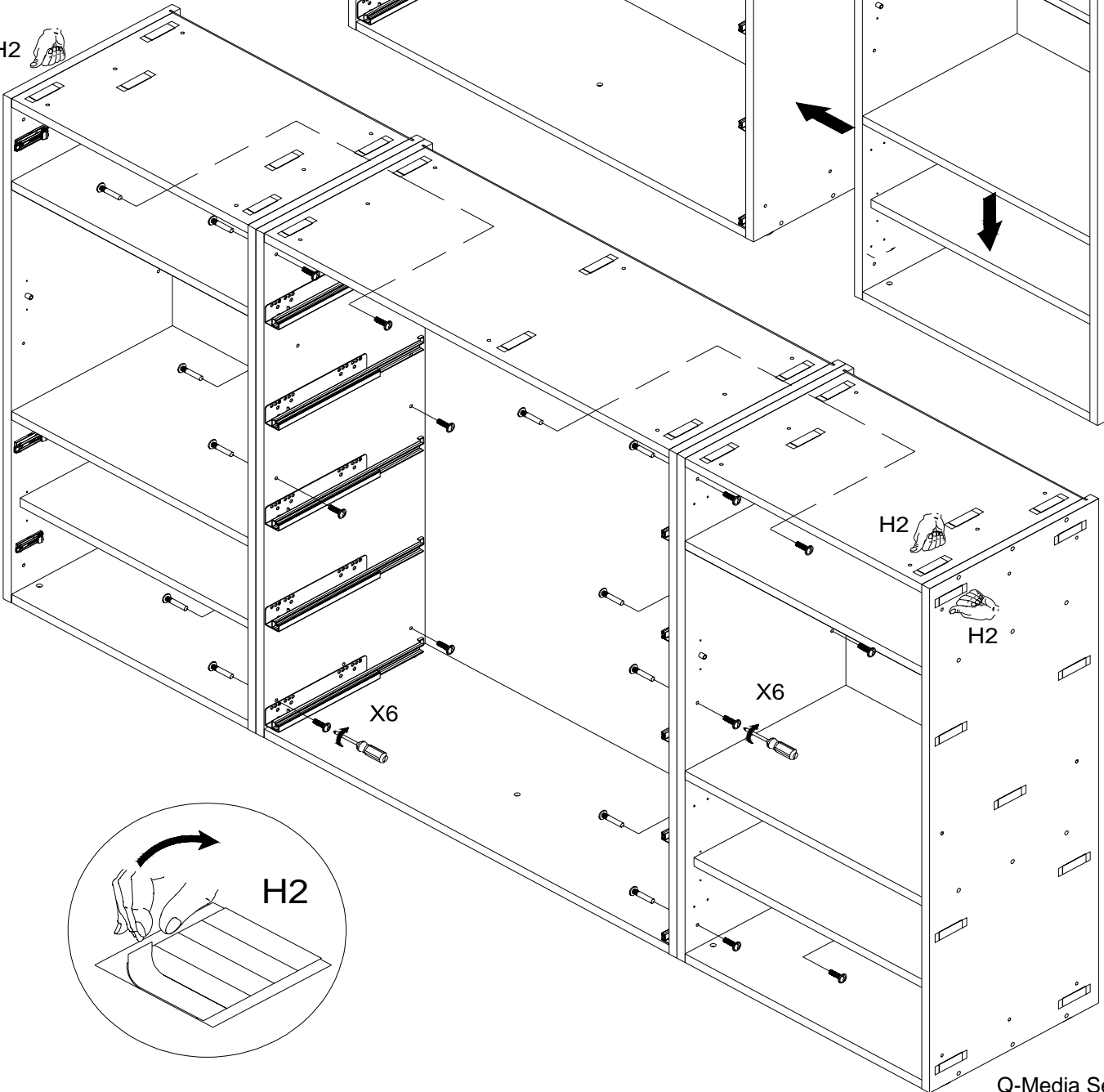

H2

X6

H2

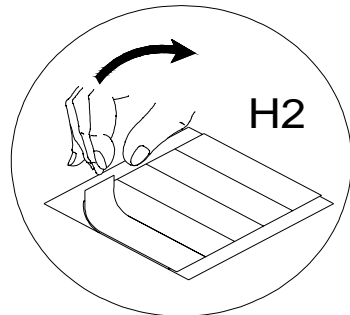

H2



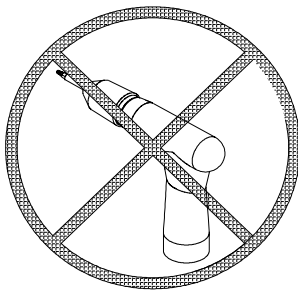

Die Schrauben zur Befestigung  
der Seiten und Böden nur mit  
einem Handschraubendreher  
anziehen.

Keinen Elektro- oder  
Akkuschrauber verwenden.

Only use a hand screwdriver to  
attach the screws. Do not use  
an electric or cordless  
screwdriver.

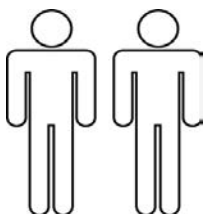
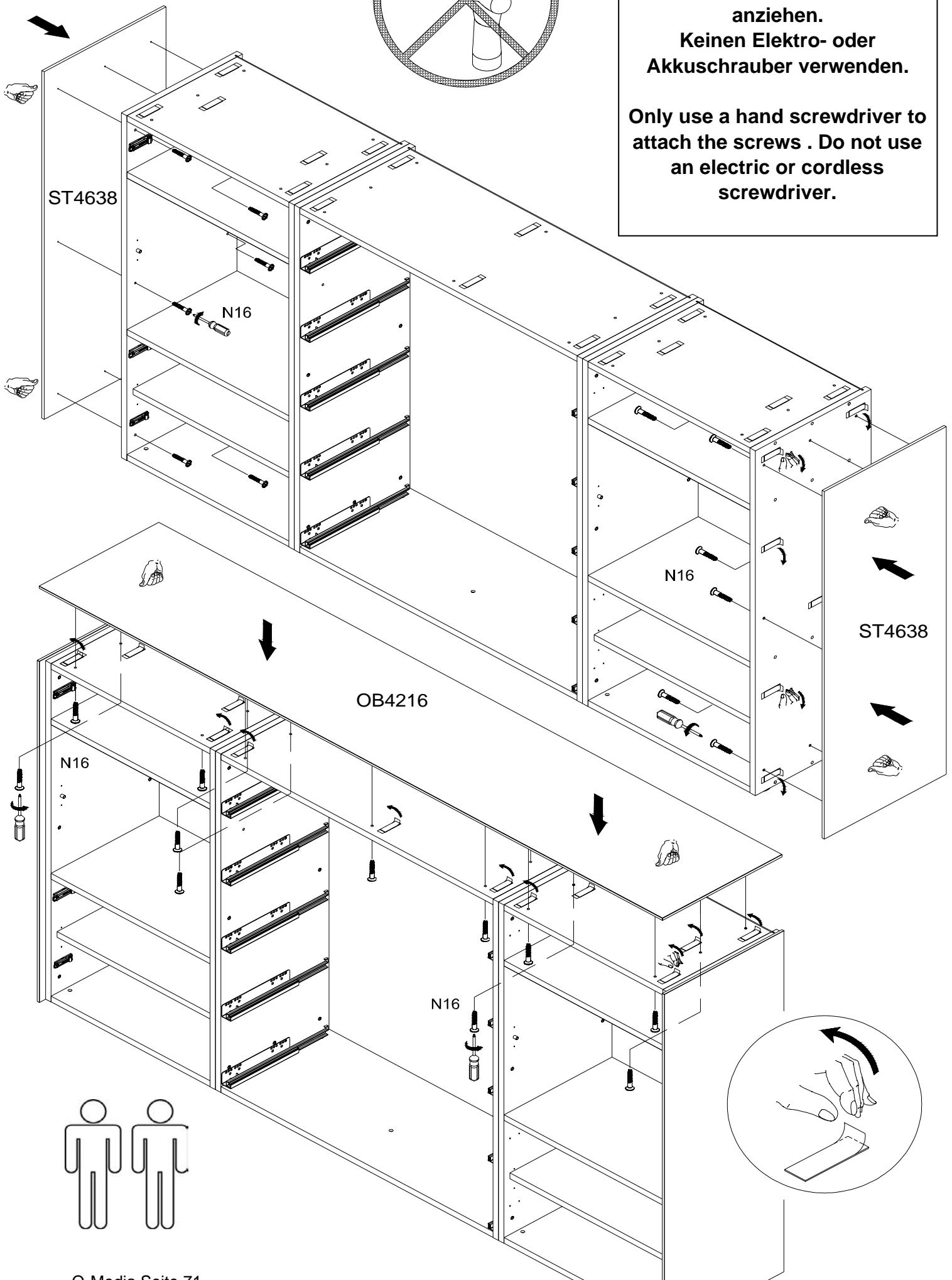

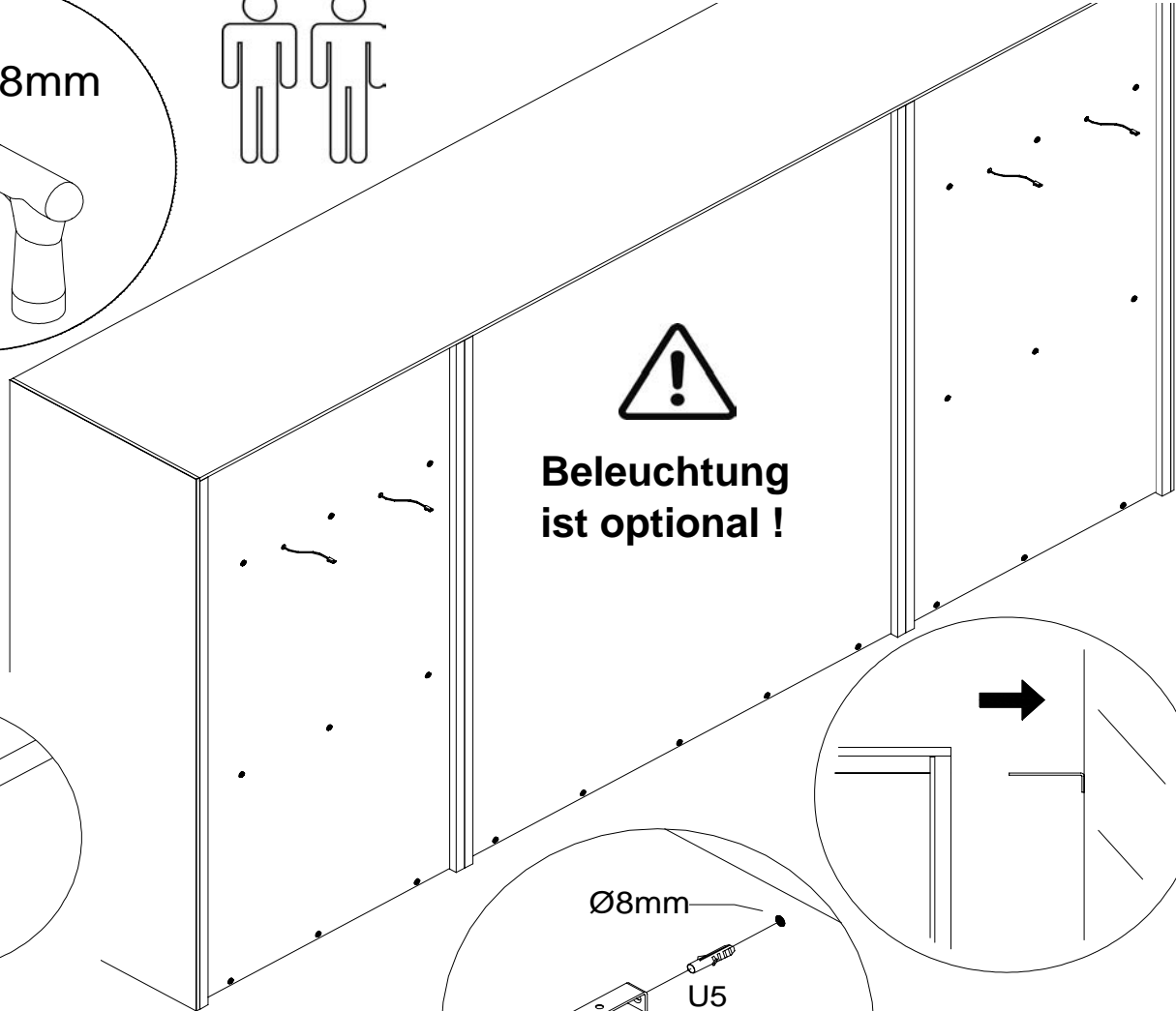
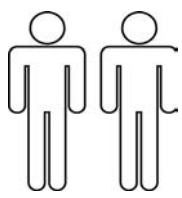
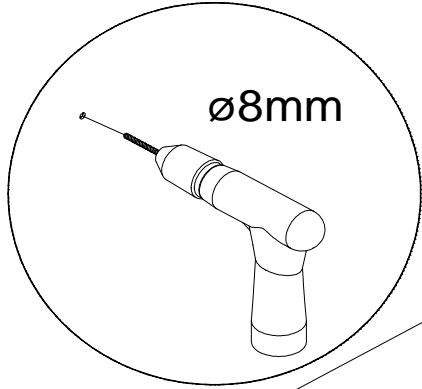

**Beleuchtung  
ist optional !**

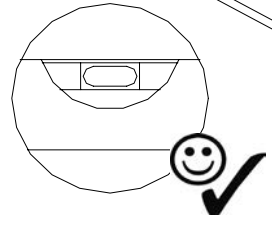
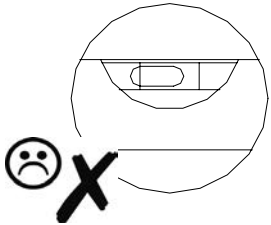
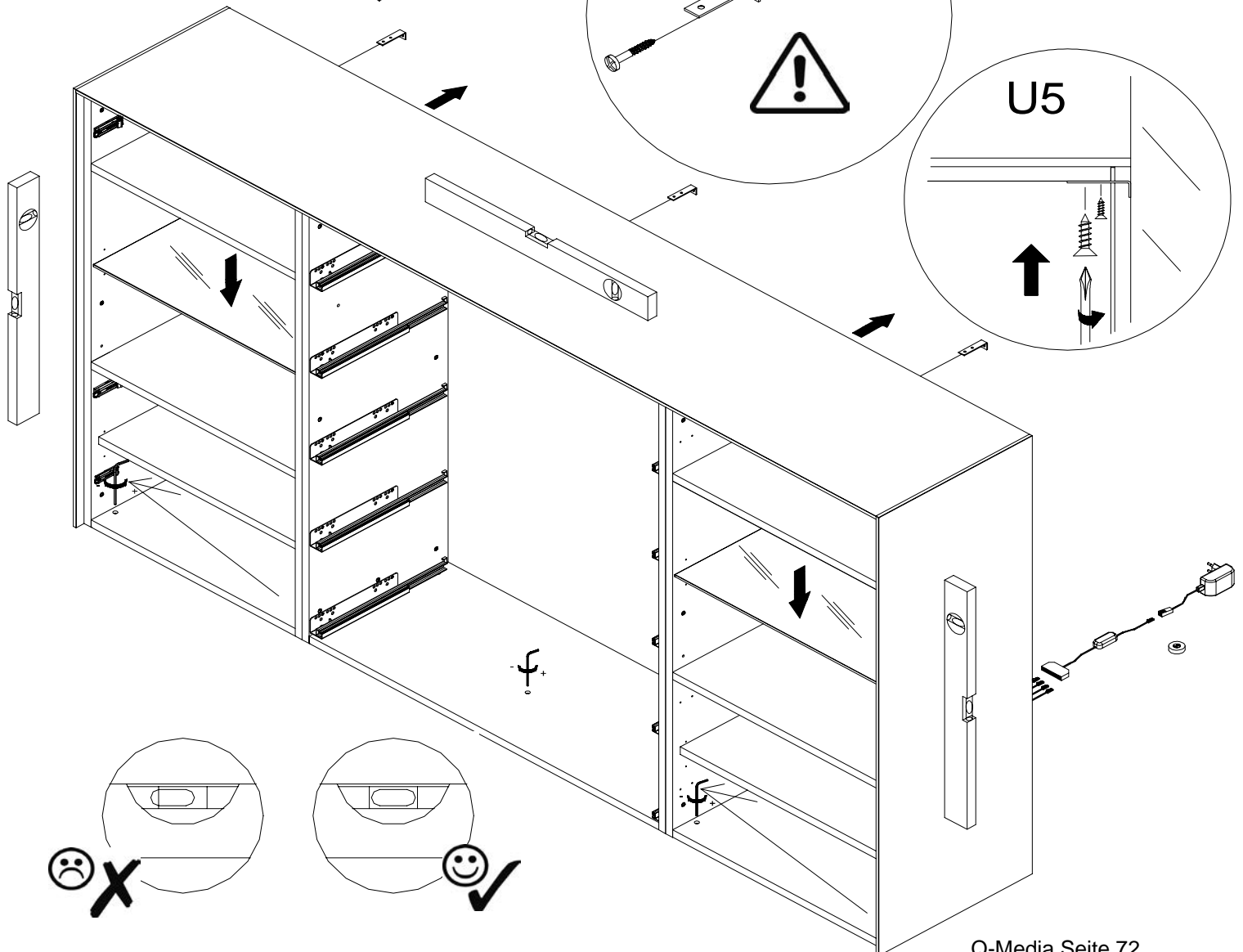
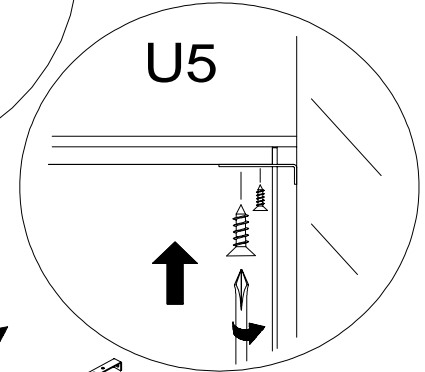
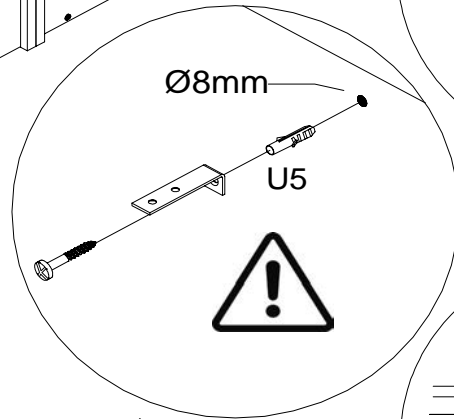
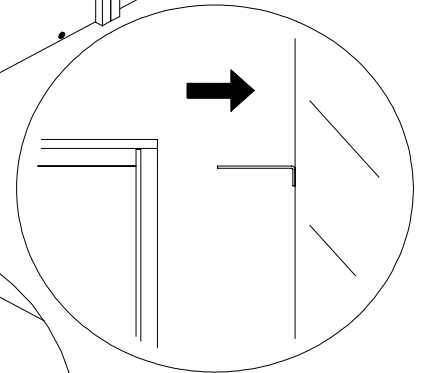
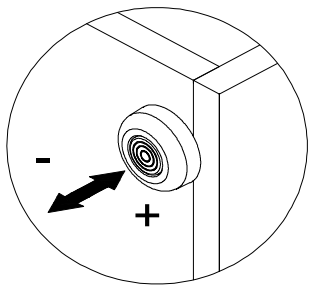

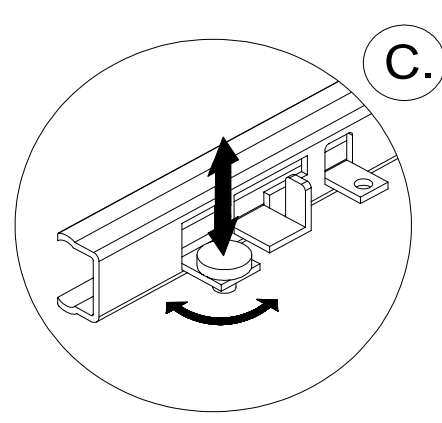
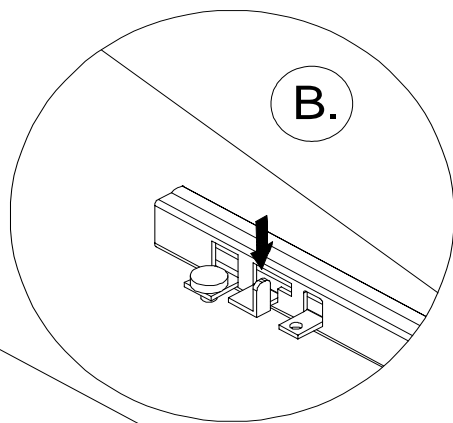
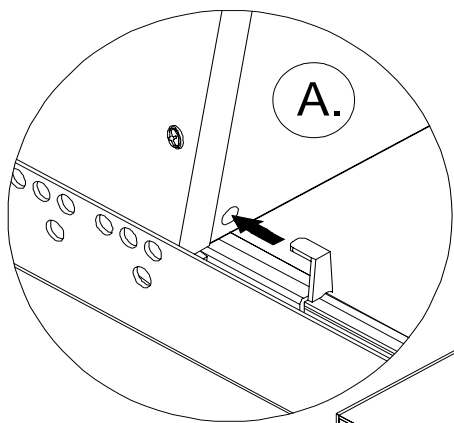

**Verstellung der Schübe:  
Adjustment of the Drawer:**

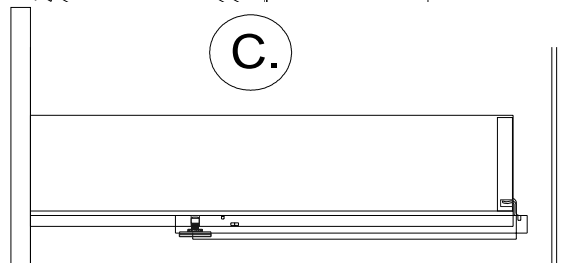
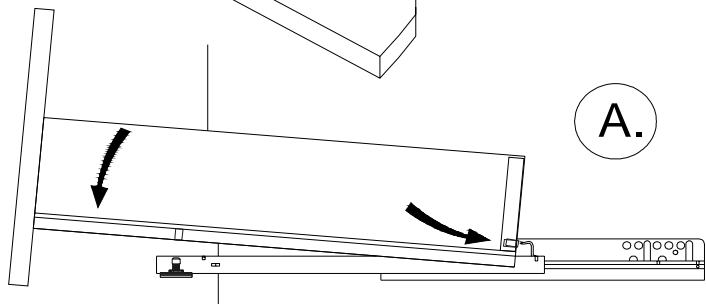
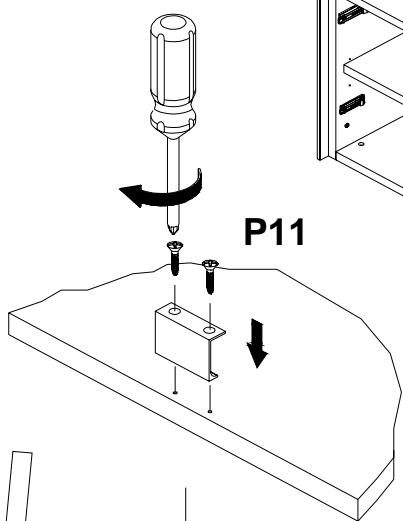

**B.**

**Montage:  
Assembly:**

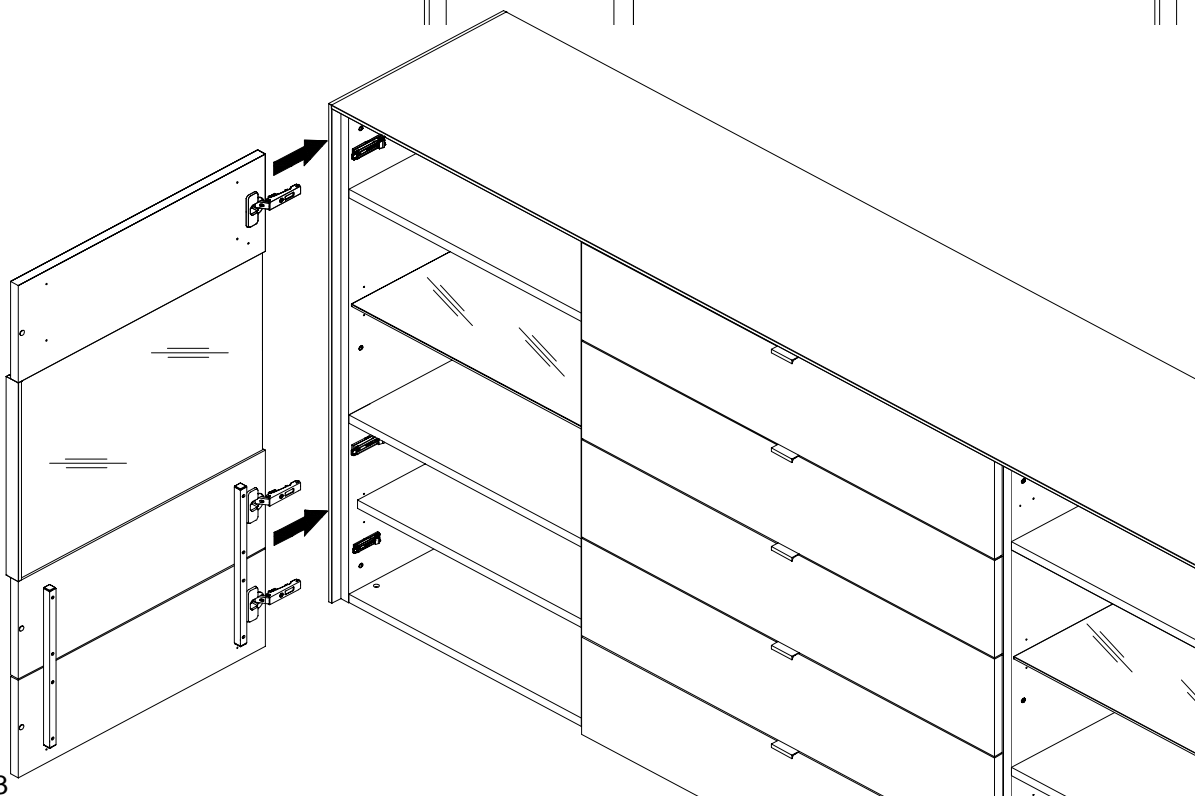
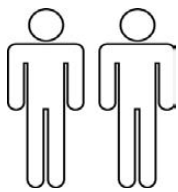

**Montage:  
Assembly:**

Die beiden mit Pfeil bezeichneten Punkte in

**2. A.**

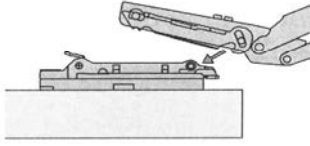

Eine leichte Drehung ausführen

**B.**

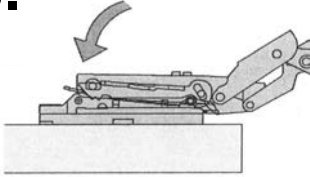

und leicht andrücken.

**C.**

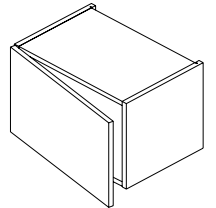
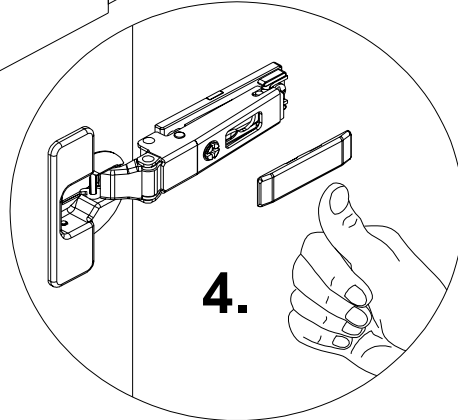
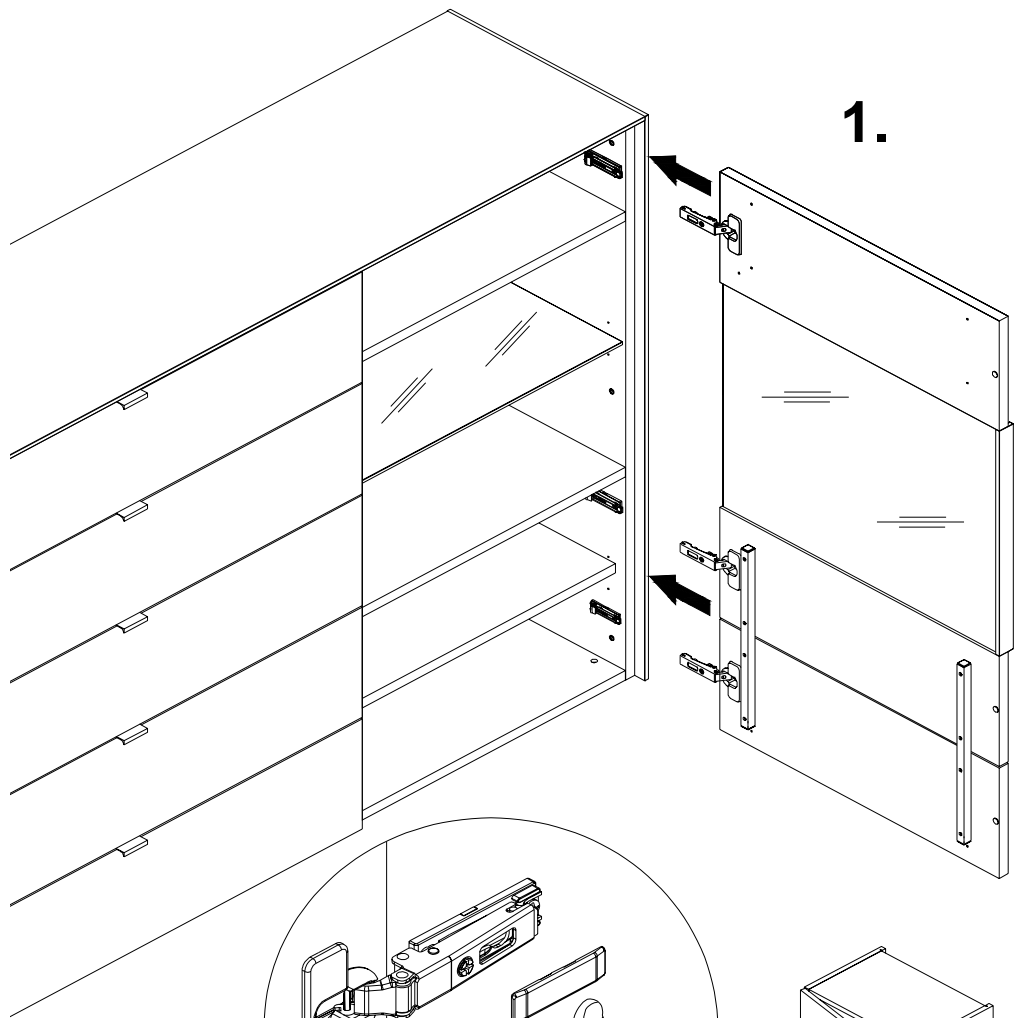
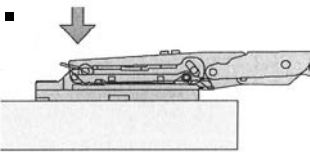

+

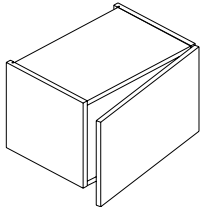

**3.**

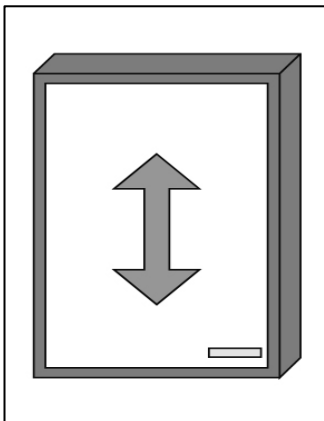
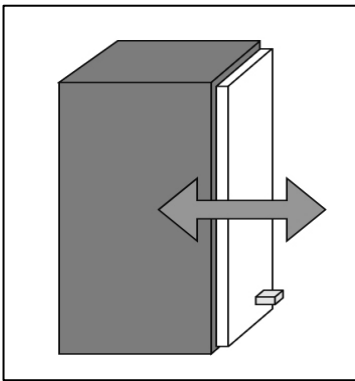
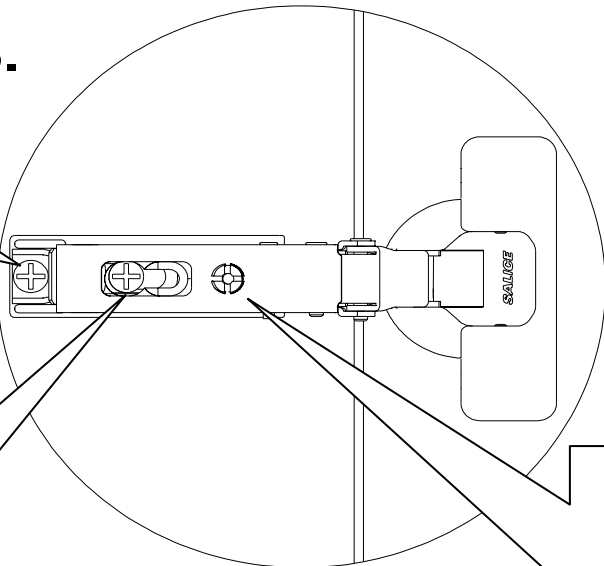

**Verstellung der Tür:  
Adjustment of the door:**

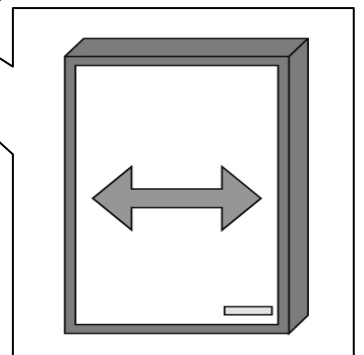

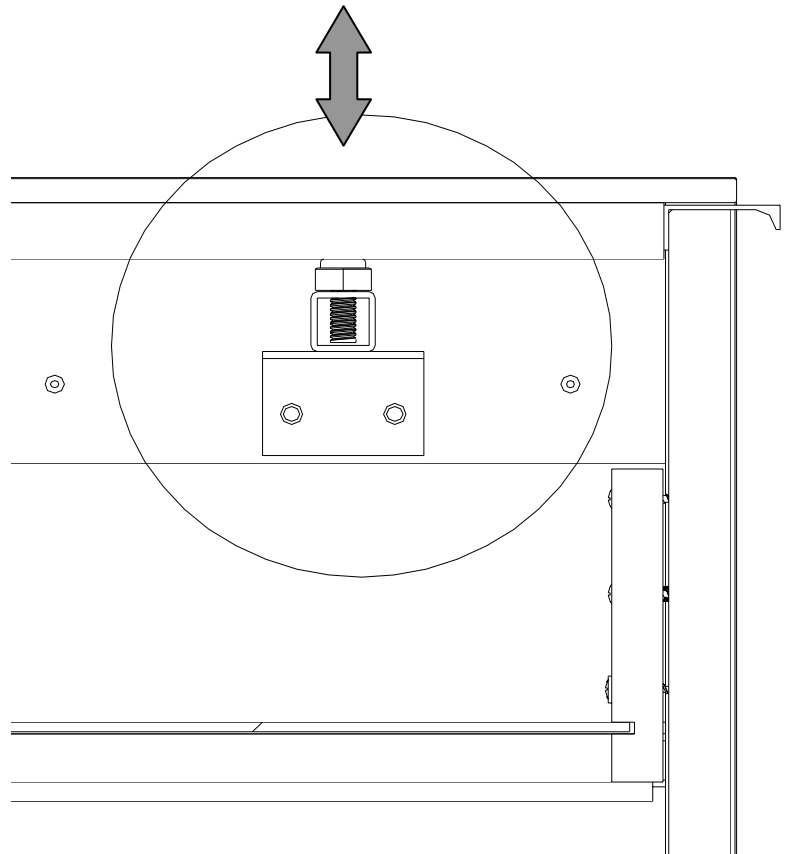
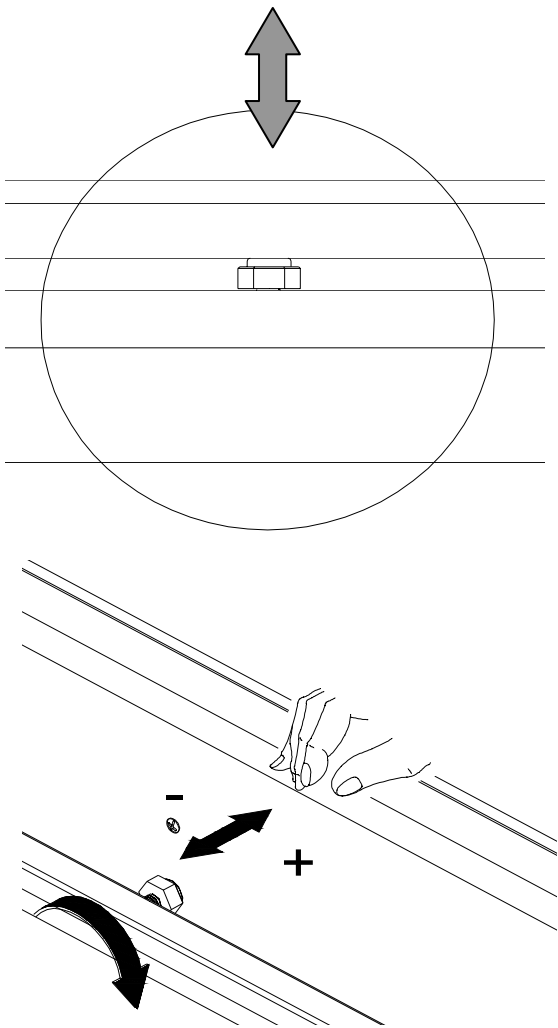

**Montage - Tipps zur Installation !**

**Assembly tips for the installation!**

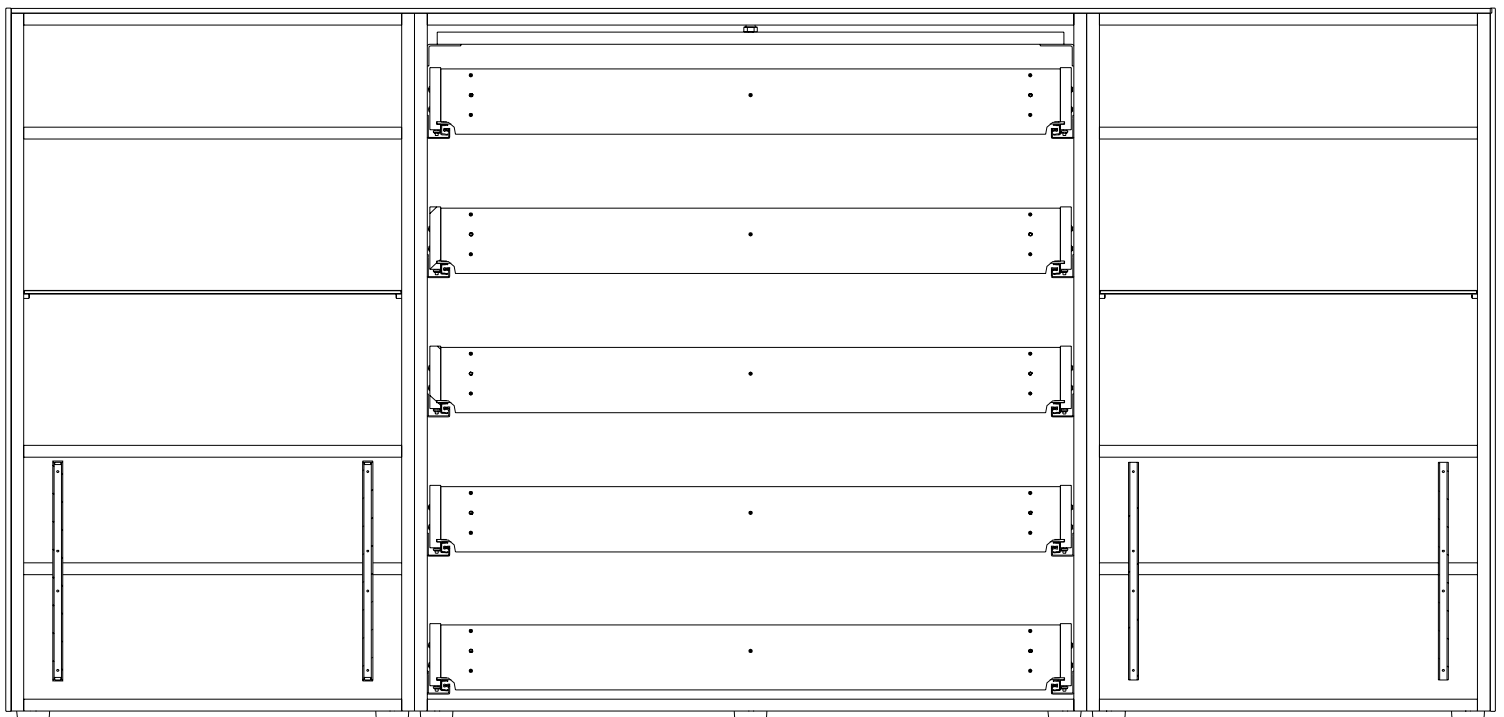

# Q-Media

## Übersicht Sideboards



**Musterring**

**Type 745**

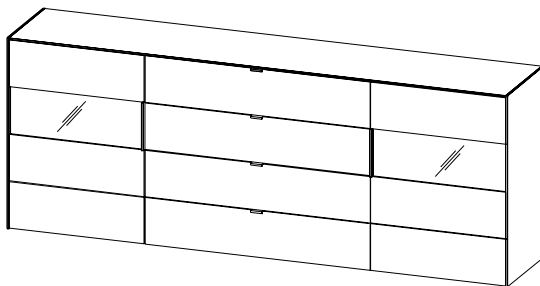

**Type 709**

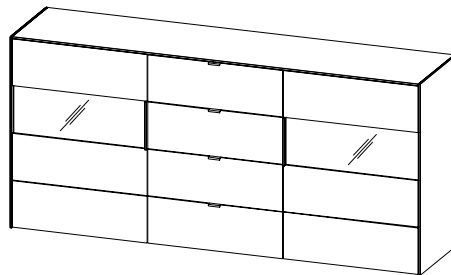

**Type 746**

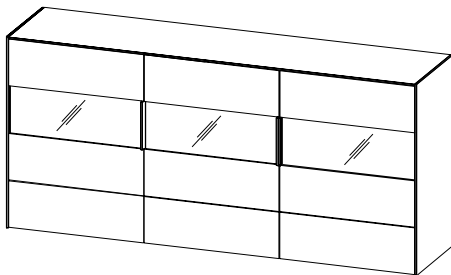

**Type 747**

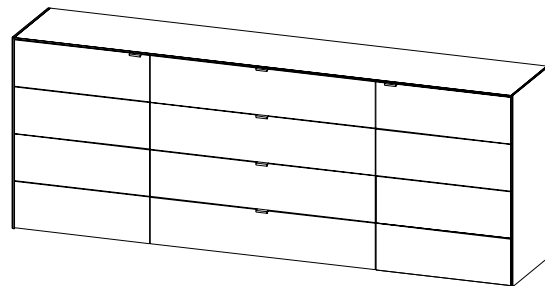

**Type 748**

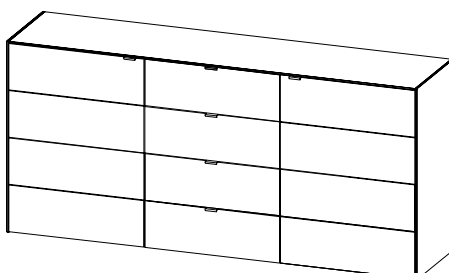

**Type 749**

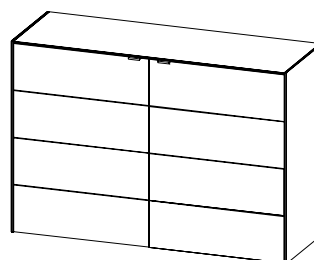



# Musterring

Beispiel  
exampel



Type 709

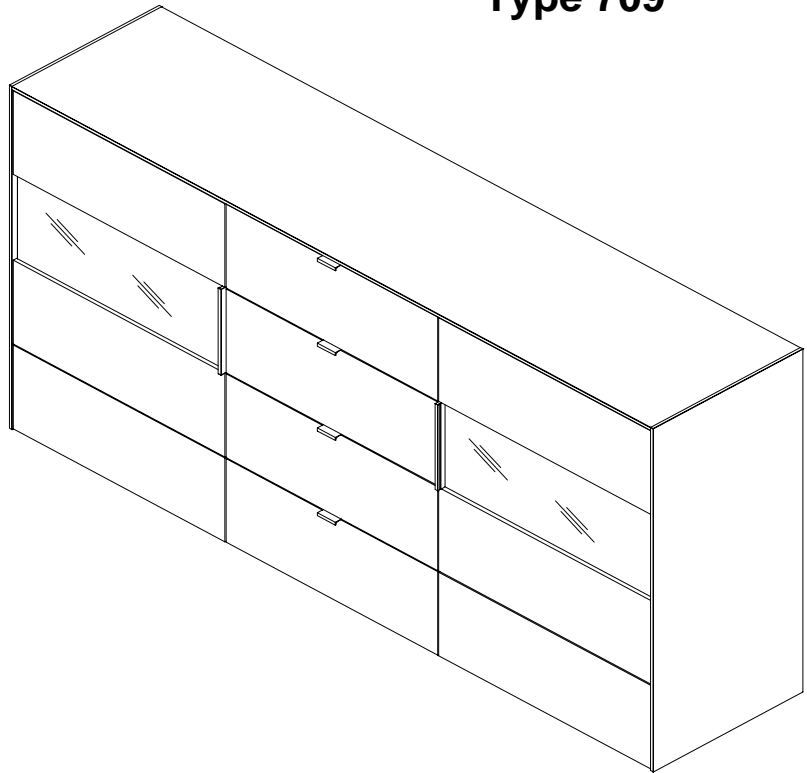

### Beschlagteile Typ 709

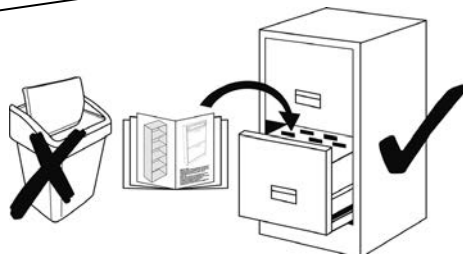
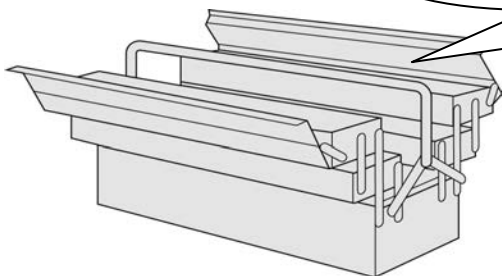
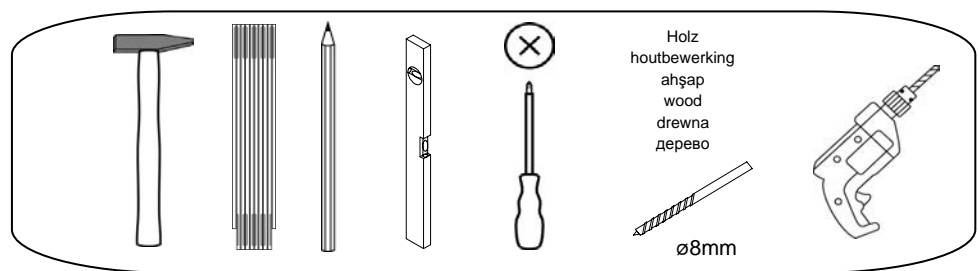
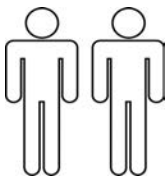
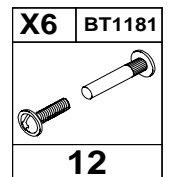
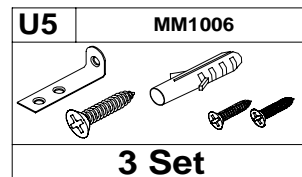
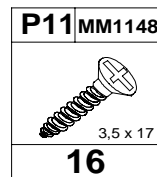
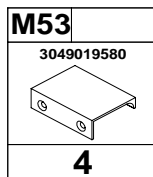
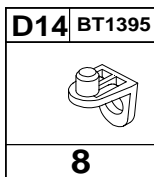
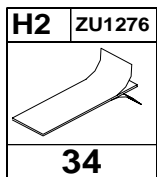

# Type 709 bestehend aus:

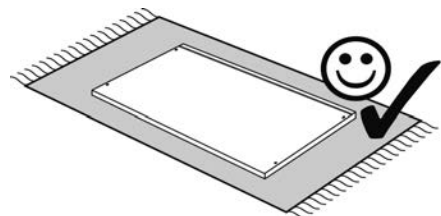
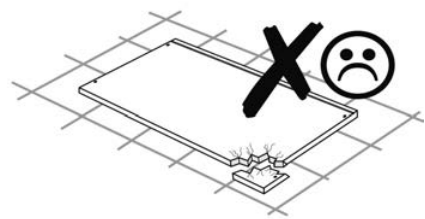
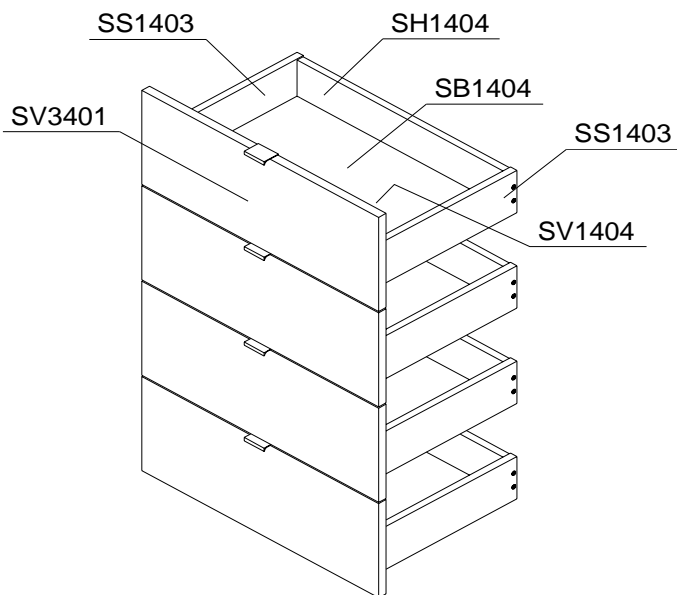
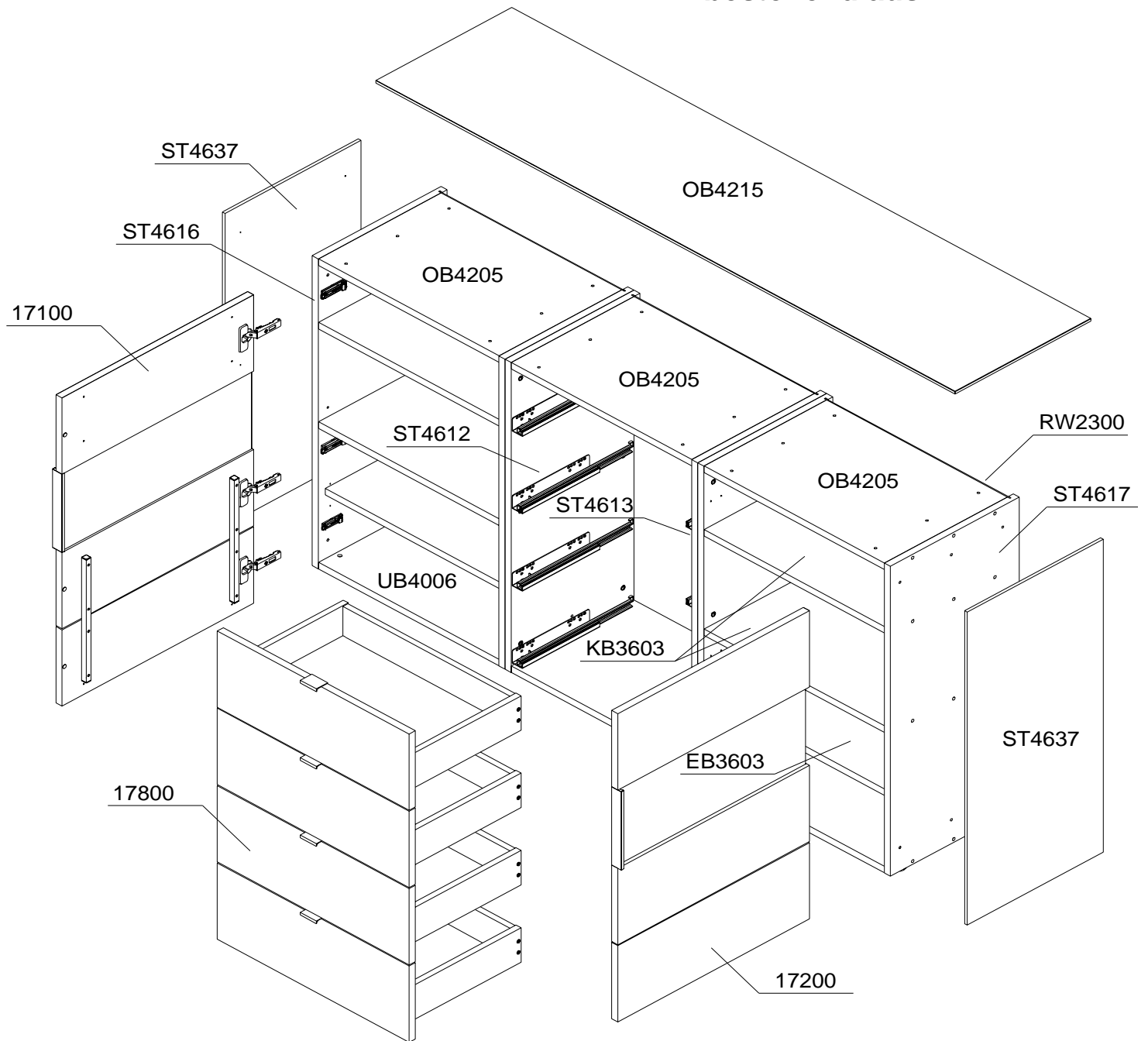



**Demontage:  
Dismounting:**

**1.A.**

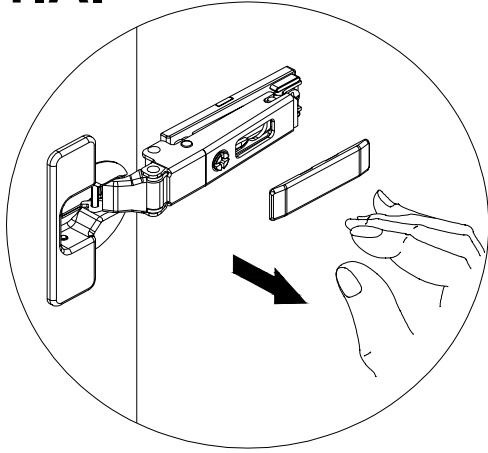

**B.**

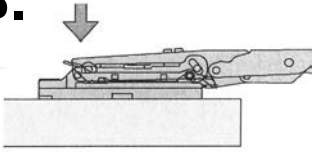

Das Lösen des Bandarmes von der Montage  
Druck auf die beiden mit Pfeil bezeichneten

**C.**

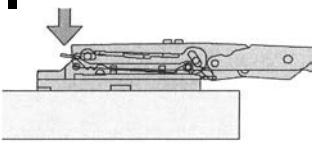

**3.**

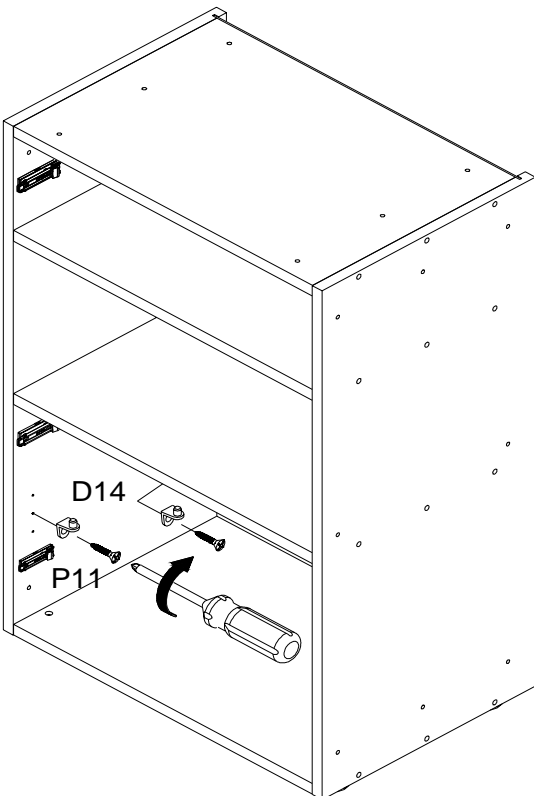

**2.**

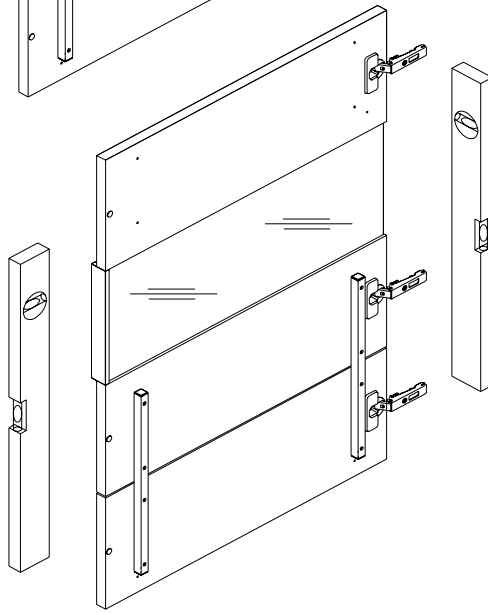
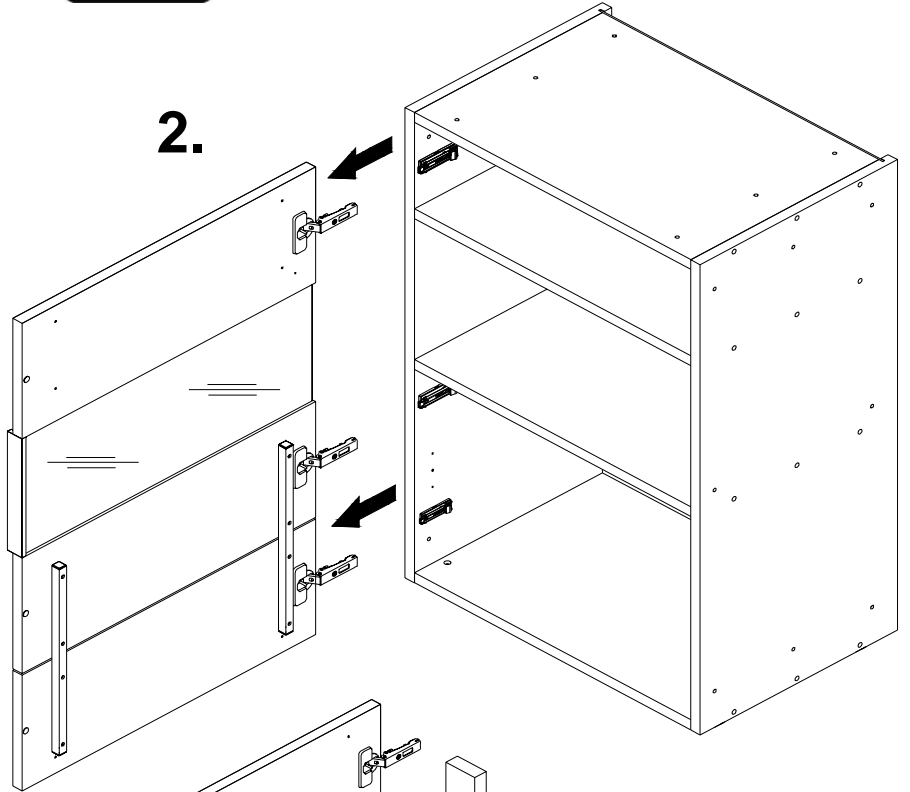

**Achtung Bruchgefahr:  
Immer vor Durchbiegung  
schützen !**

**Always protect from  
bending: Warning Danger  
of breakage !**

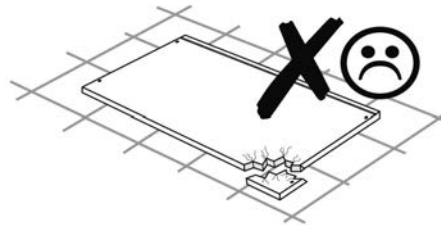
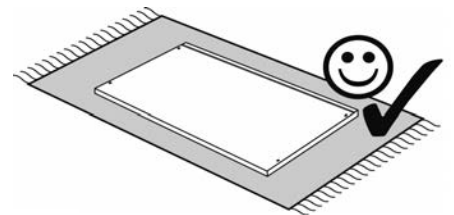
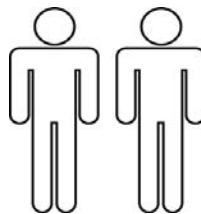

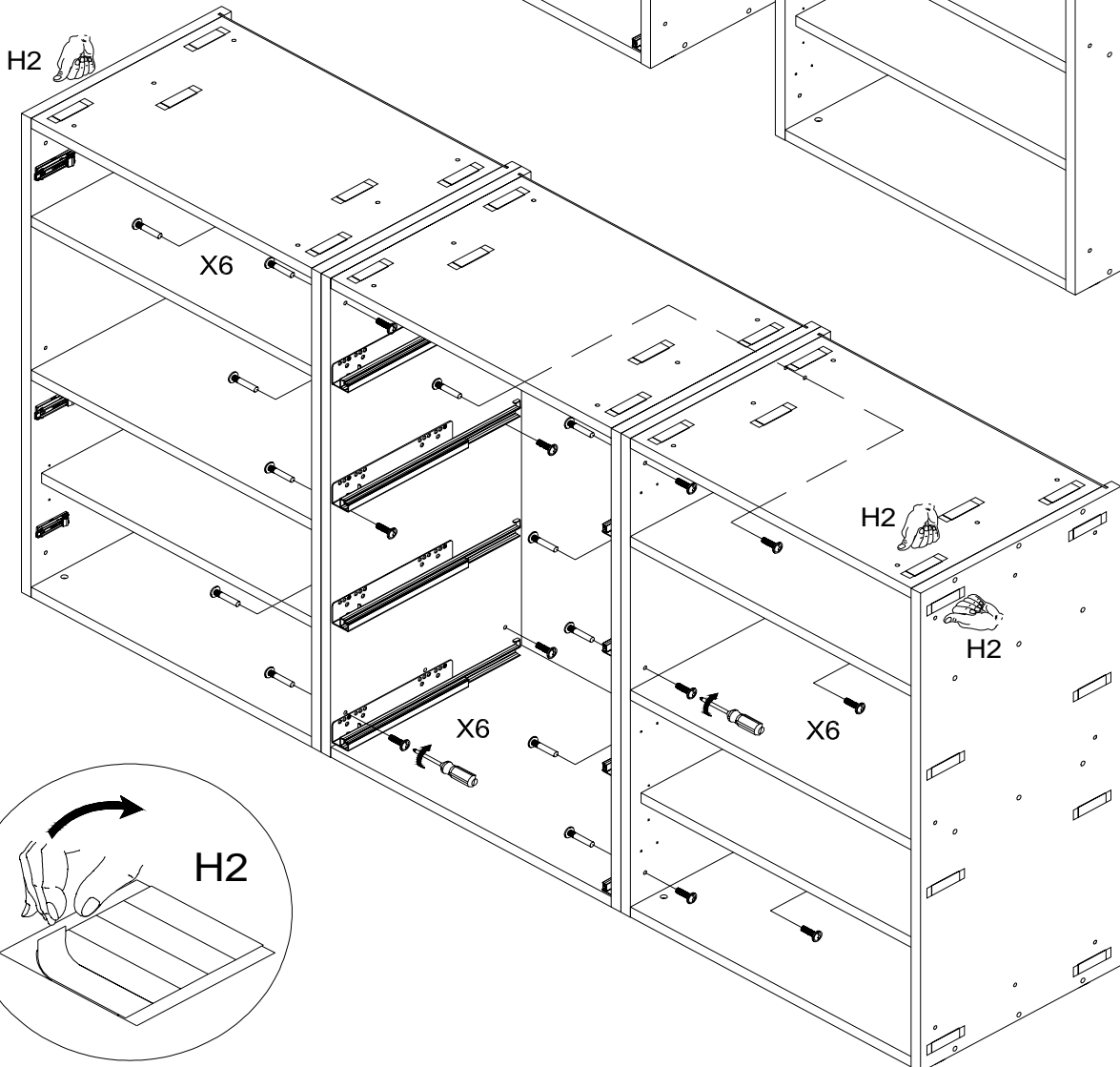
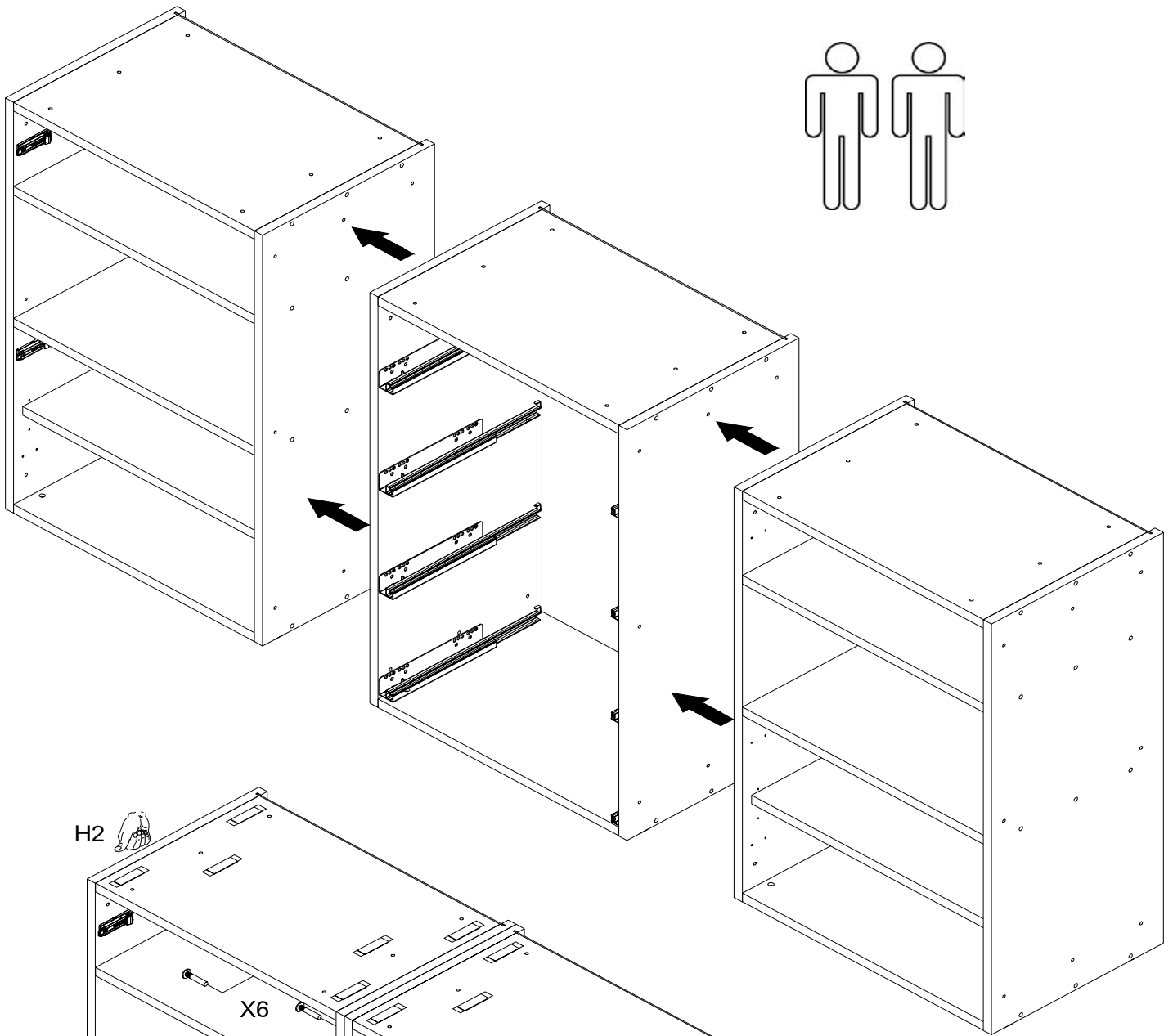

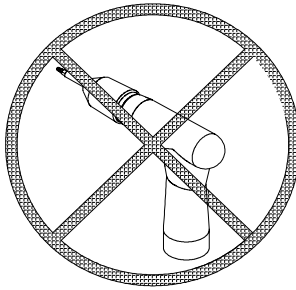

Die Schrauben zur Befestigung  
der Seiten und Böden nur mit  
einem Handschraubendreher  
anziehen.

Keinen Elektro- oder  
Akkuschrauber verwenden.

Only use a hand screwdriver to  
attach the screws . Do not use  
an electric or cordless  
screwdriver.

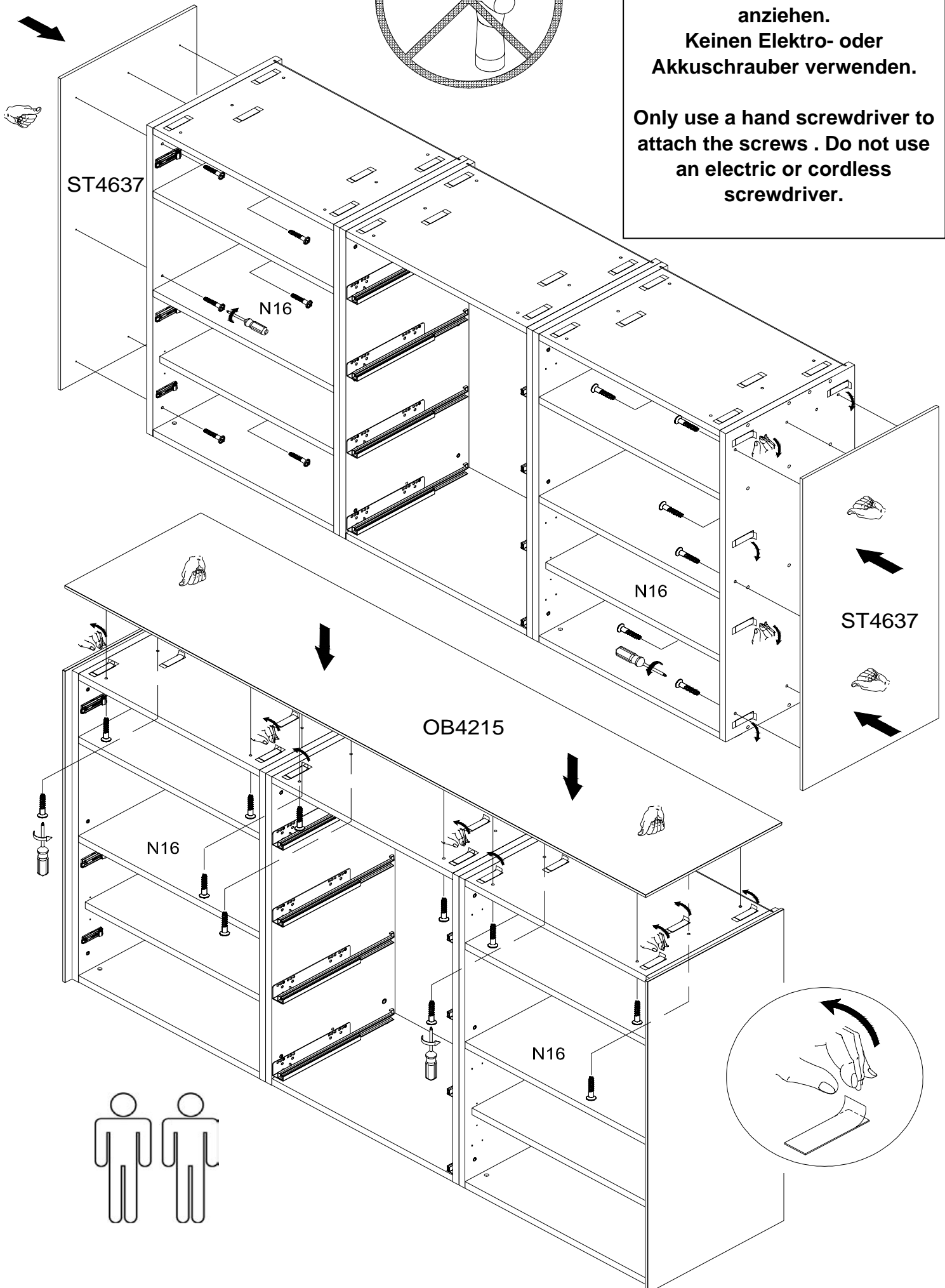

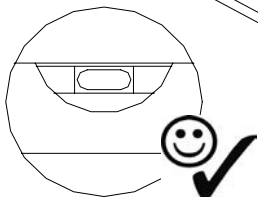
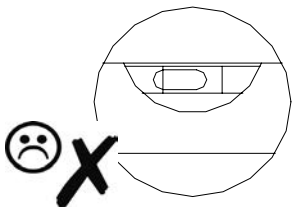
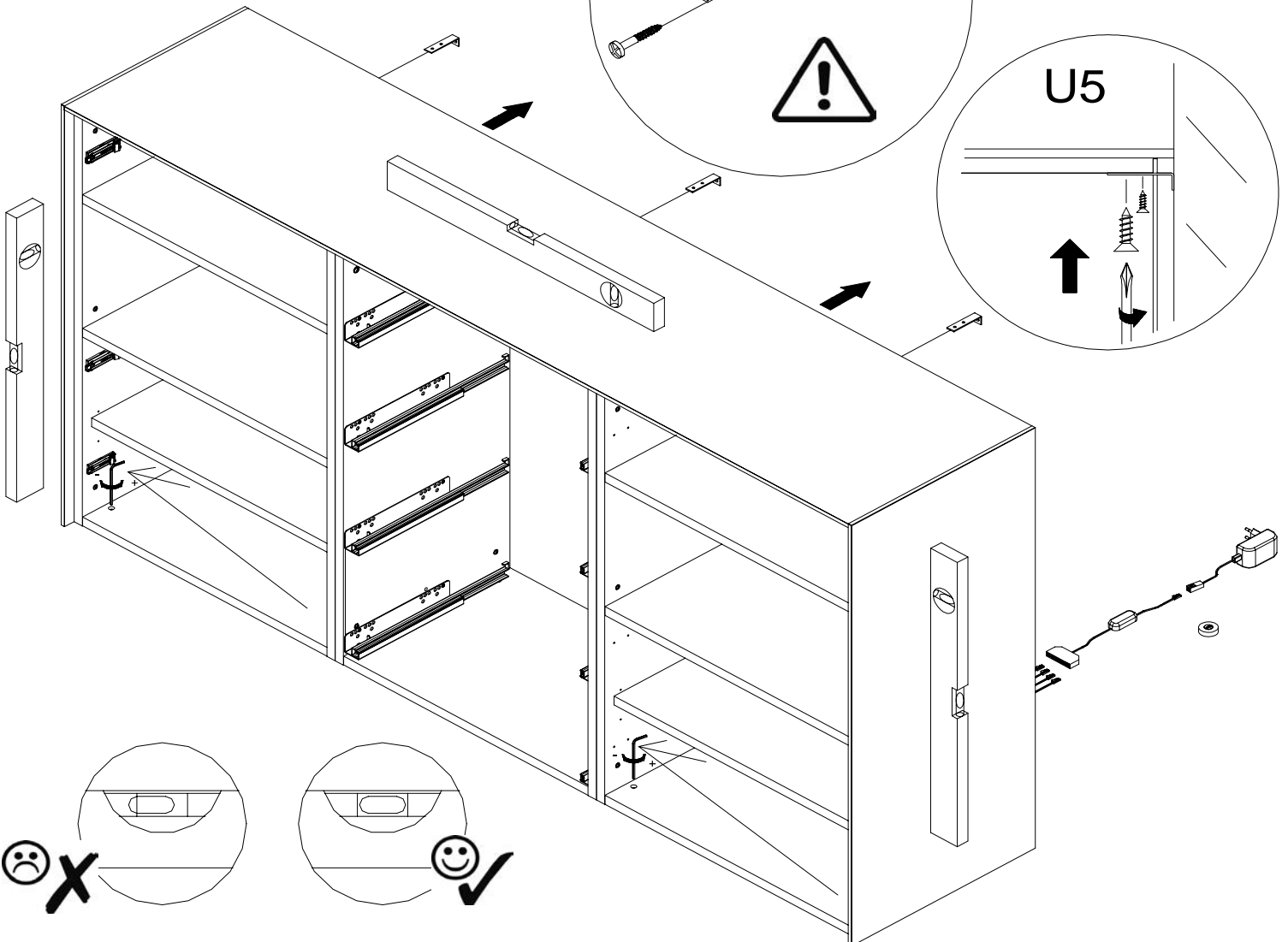
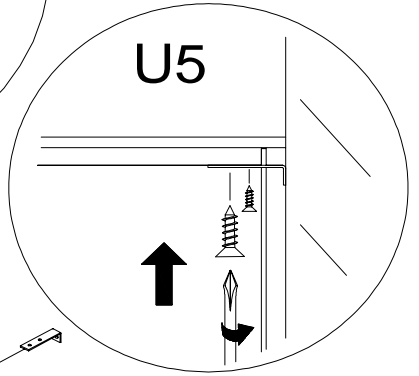
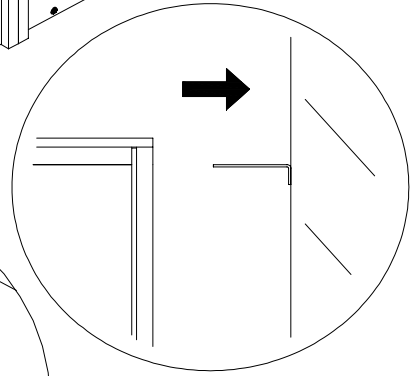
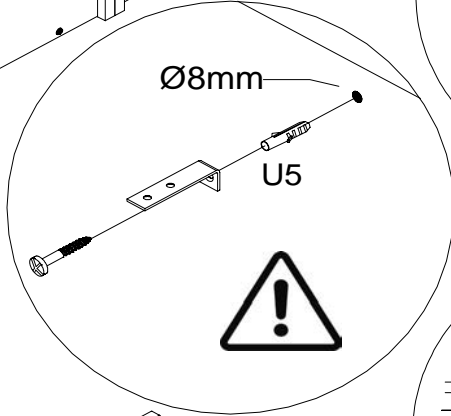
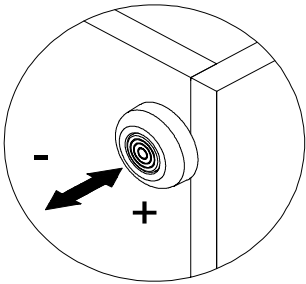
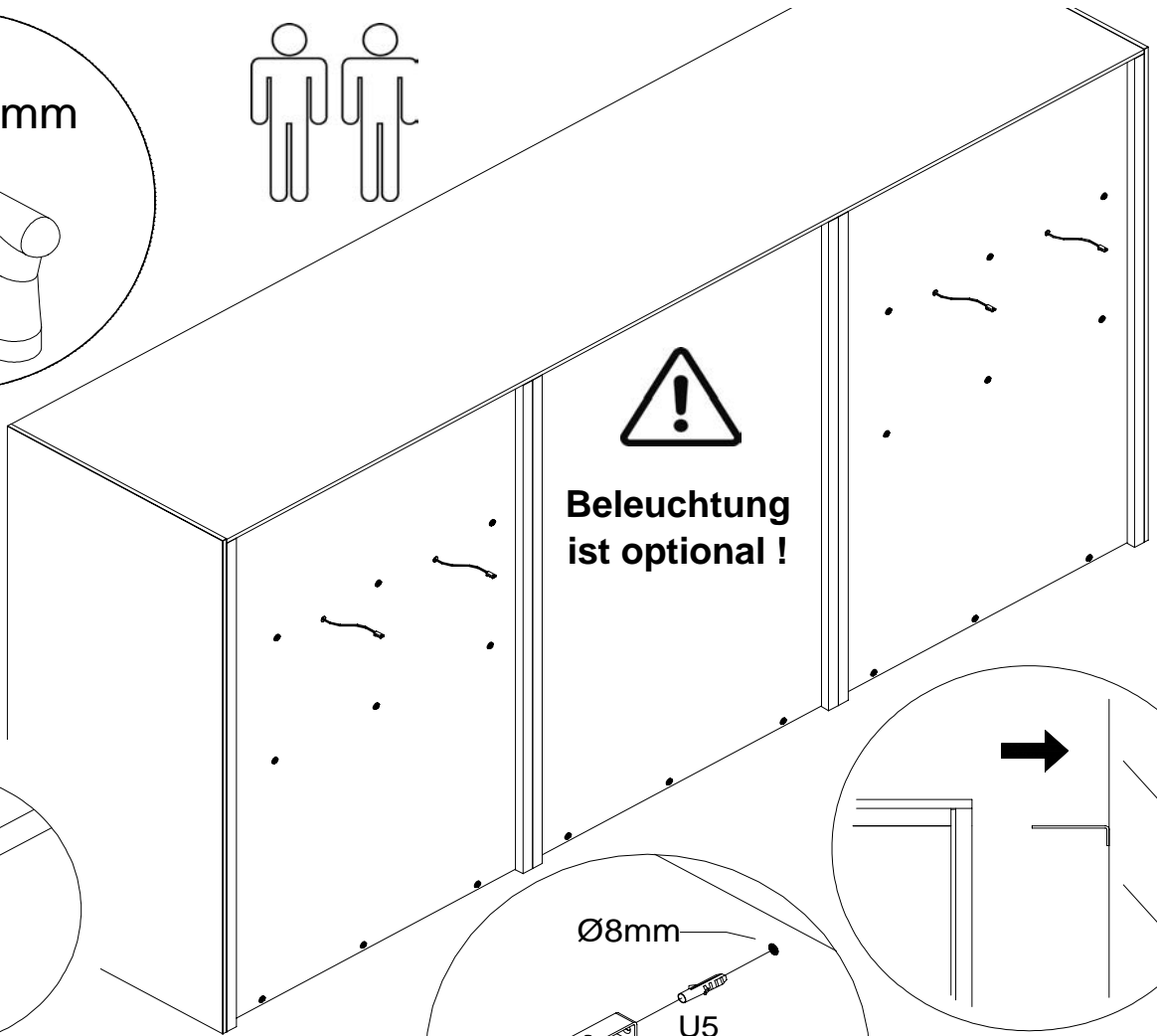
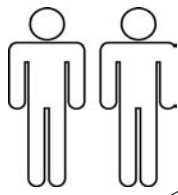
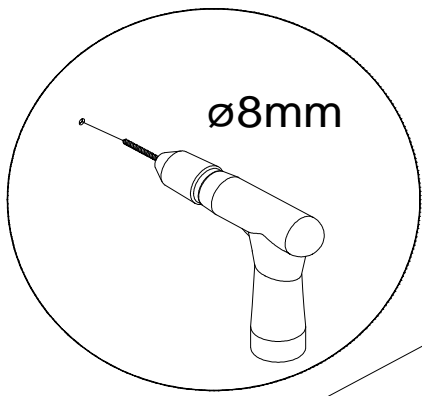

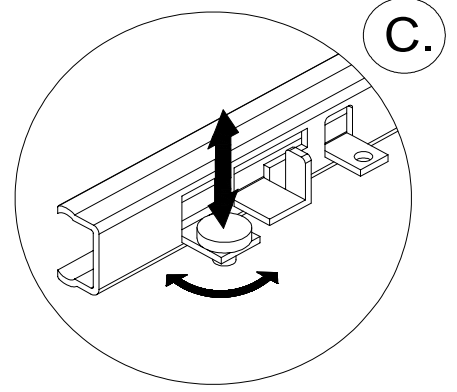
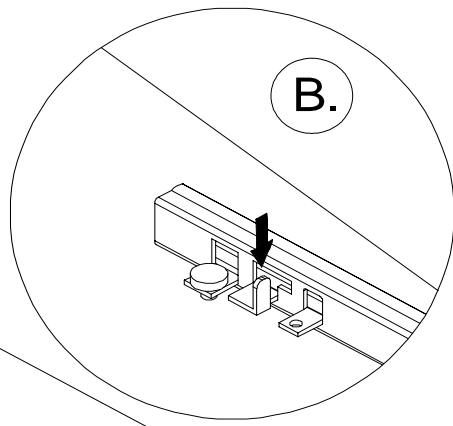
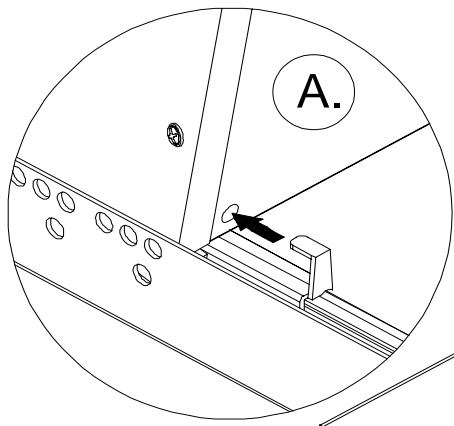

**Verstellung der Schübe:  
Adjustment of the Drawer:**

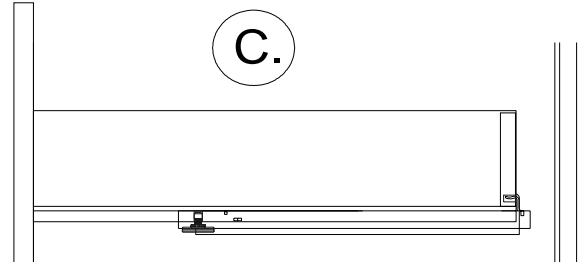
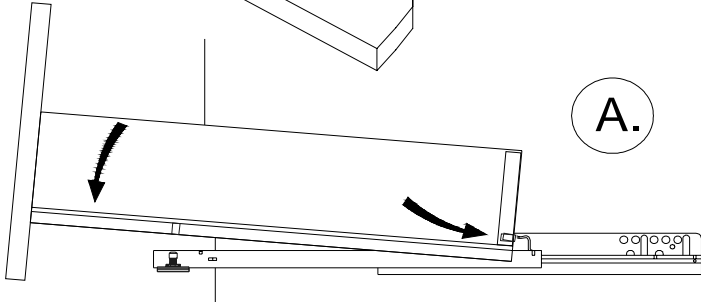
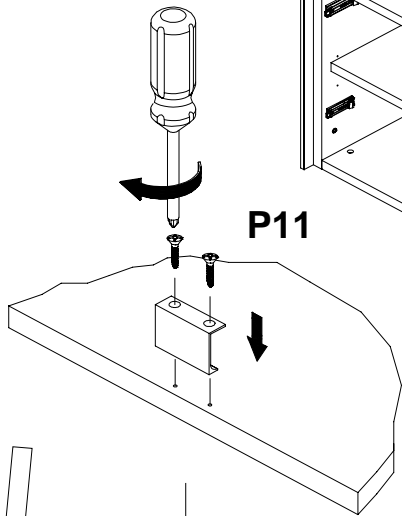
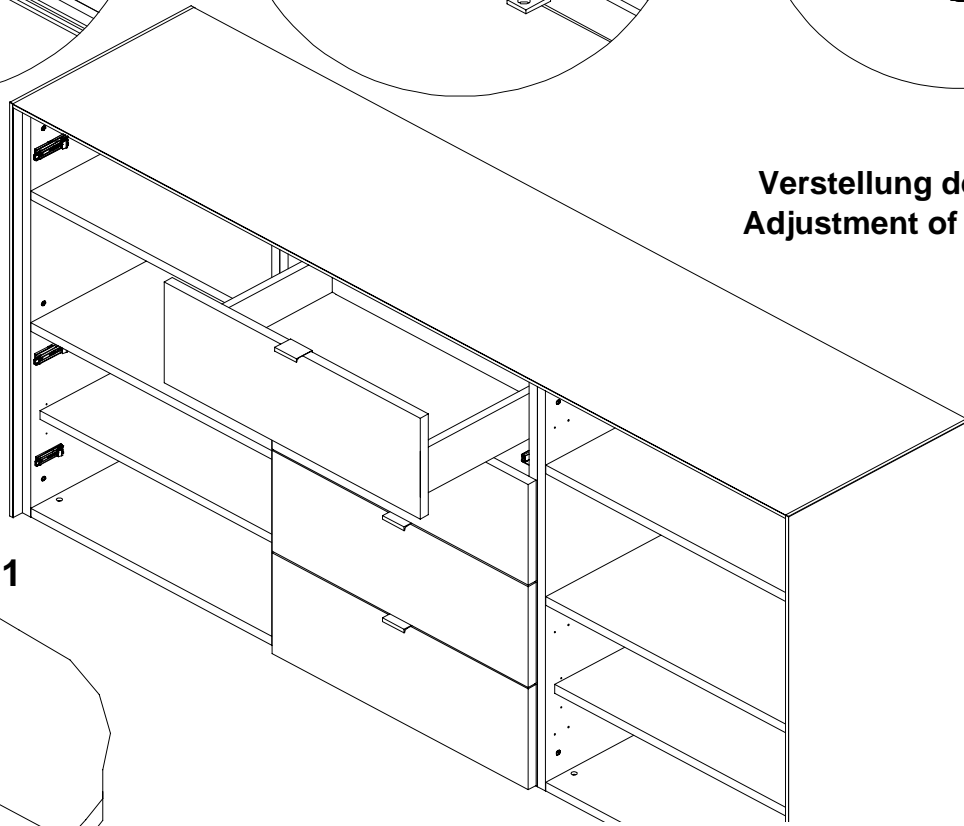

**B.**

**Montage:  
Assembly:**

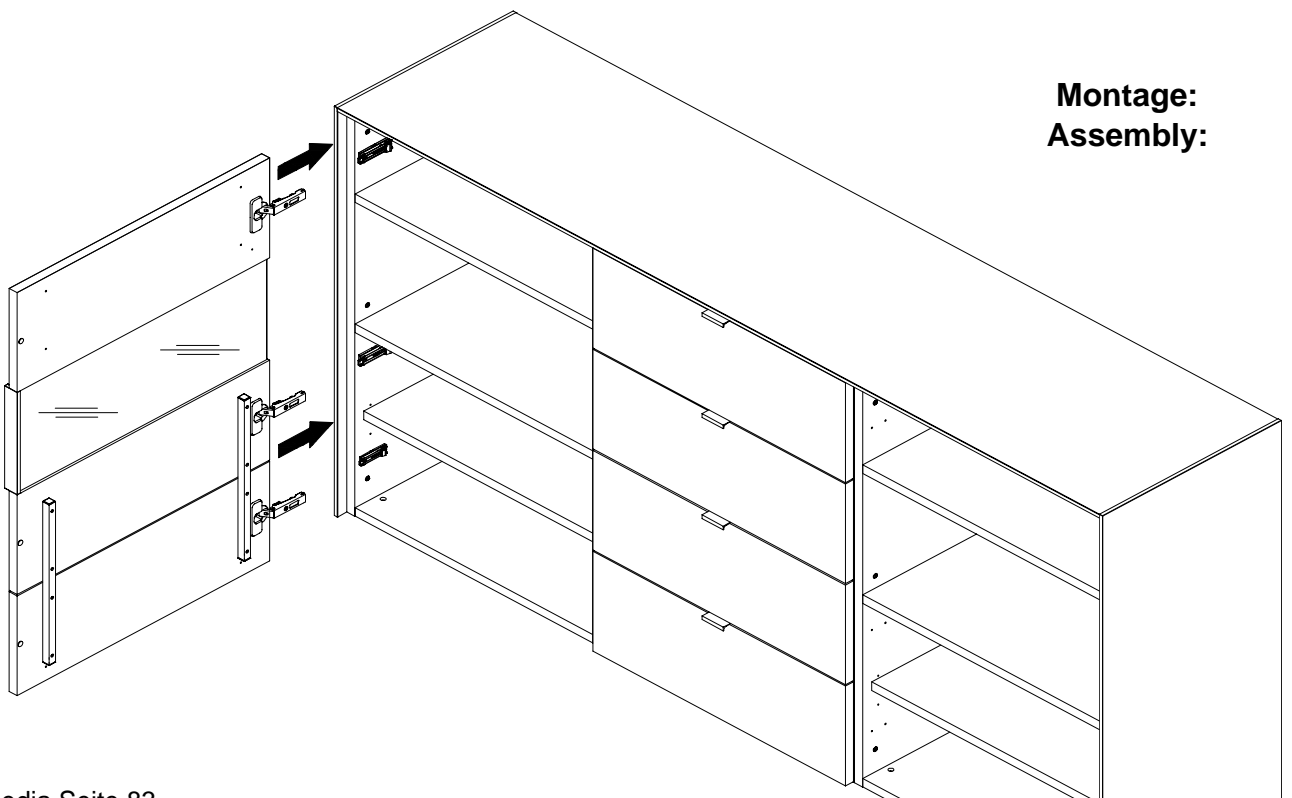

# Montage: Assembly:

Die beiden mit Pfeil bezeichneten Punkte in

## 2. A.

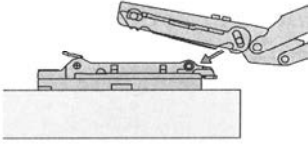

Eine leichte Drehung ausführen

## B.

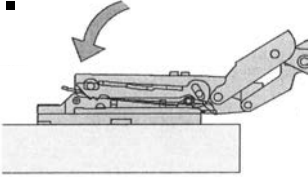

und leicht andrücken.

## C.

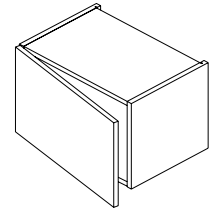
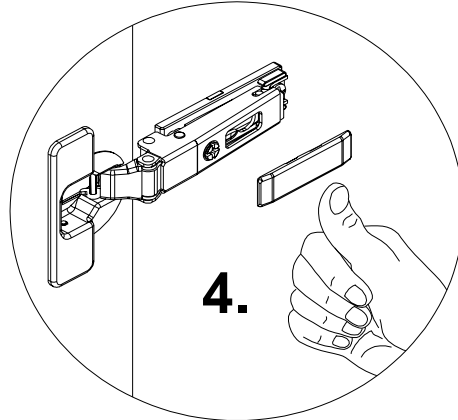
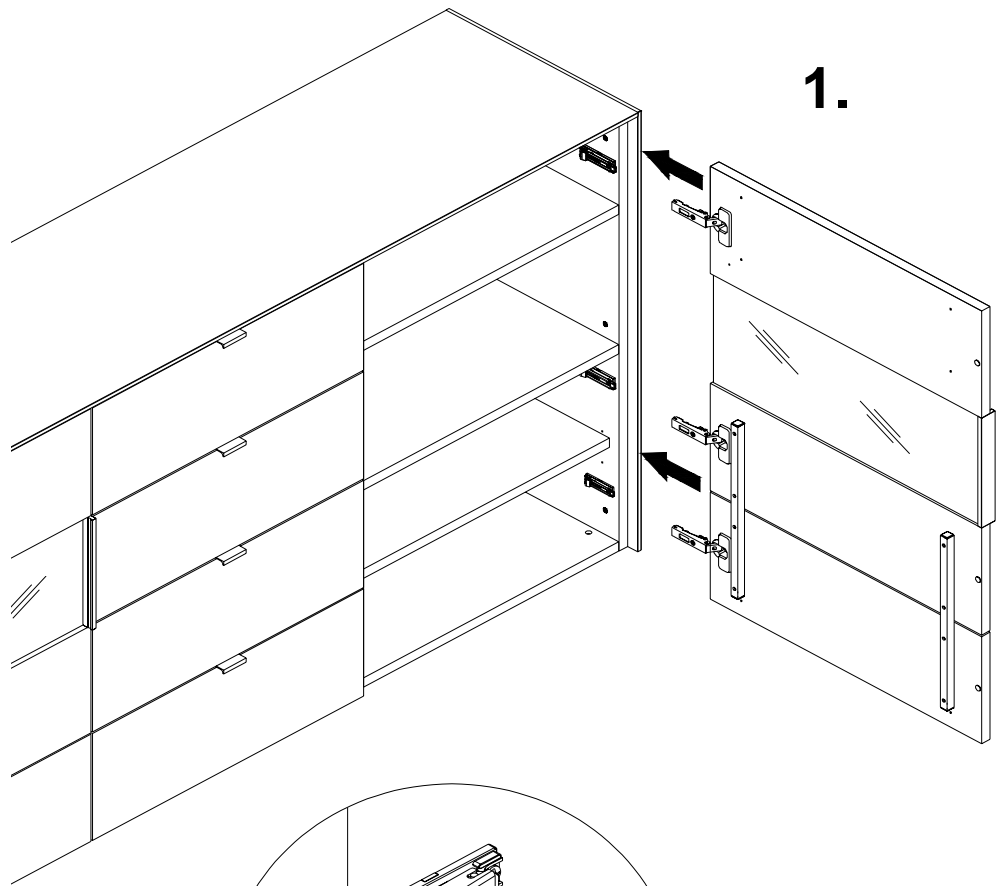
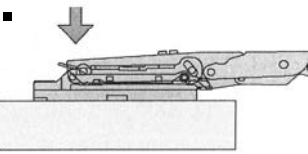

+

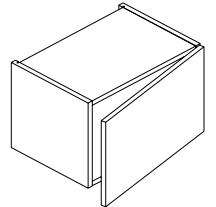

## 3.

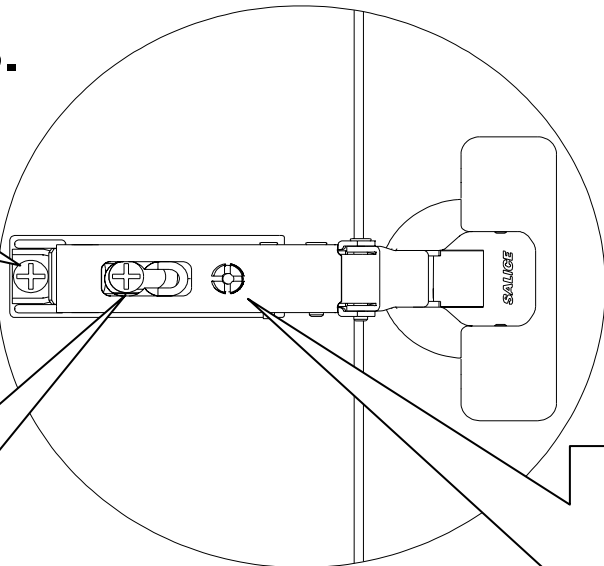

Verstellung der Tür:  
Adjustment of the door:

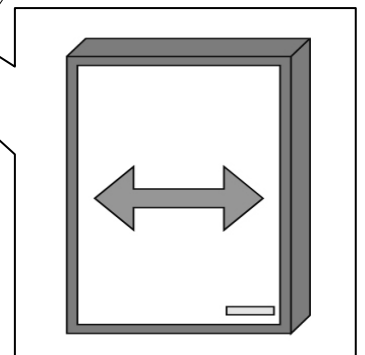
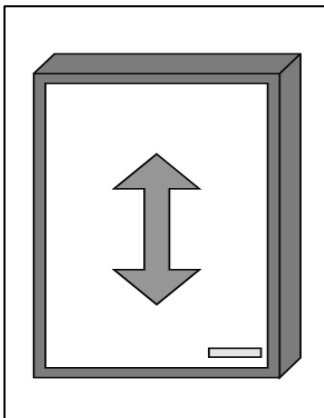
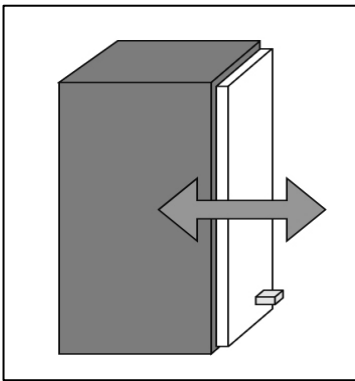

# Q-Media

## Übersicht Vitrinen



**Musterring**

**Type 181**

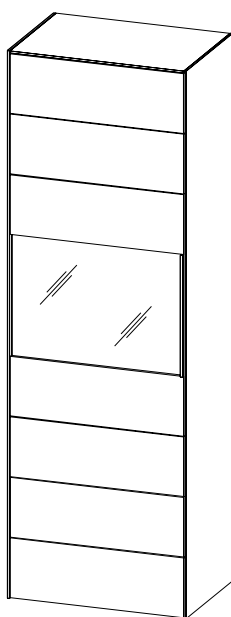

**Type 182**

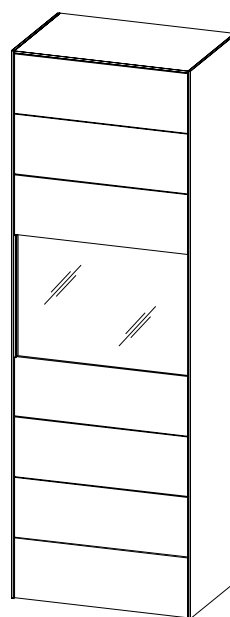

**Type 713**

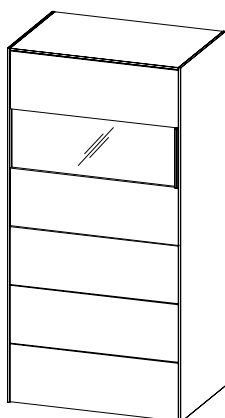

**Type 714**

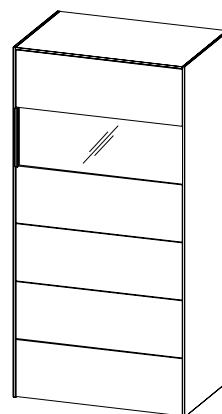



# Musterring



**Beispiel  
exampel**

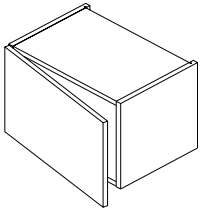

**Type 181**

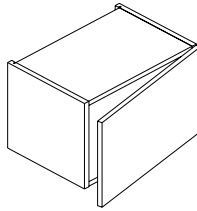

**Type 182**

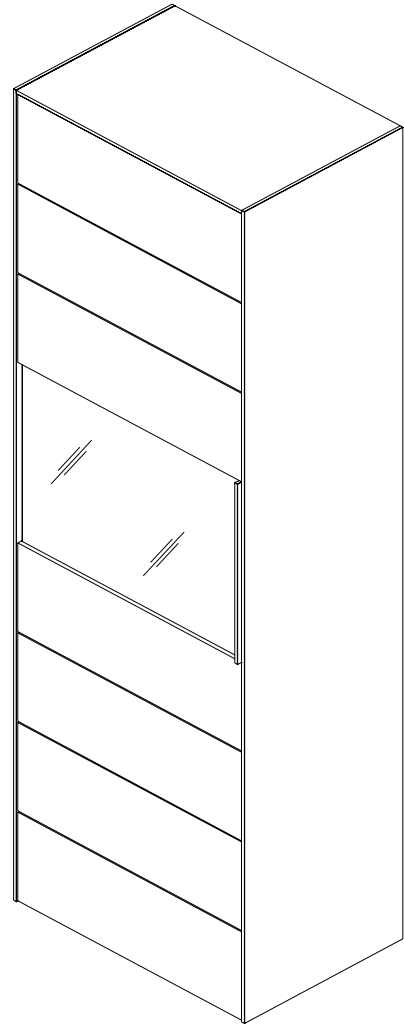

**Sehr geehrte Kundin, sehr geehrter Kunde,**

Das beigefügte Wandbefestigungsmaterial (Dübel und Schrauben) eignet sich nur für festes Mauerwerk (z.B. Beton- oder Ziegelwände). Für andere Wandaufbauten sind eventuell Spezialdübel und andere Schrauben notwendig. Ziehen Sie gegebenenfalls eine Fachkraft zurate. Technische Änderungen vorbehalten.

**Dear customer,**

the provided mounting material (dowels and screws) can only be used with solid masonry (e.g. concrete or brick walls). For other wall constructions special dowels and screws are needed. Please consider an expert in these cases. Leaving technical changes.

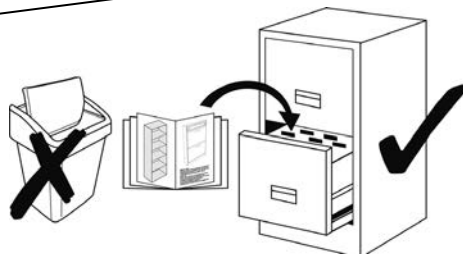
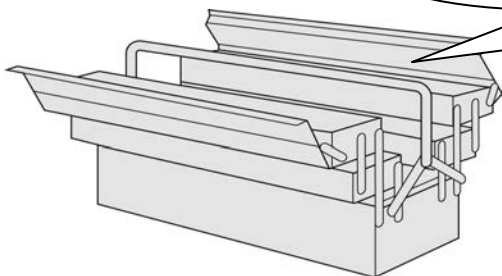
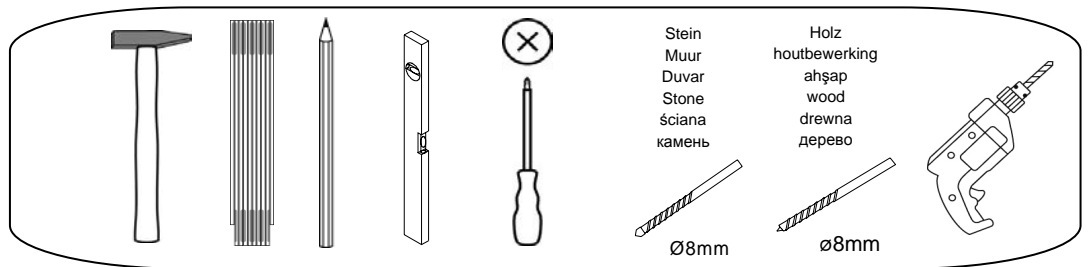
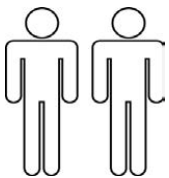



# Beschlagteile Typ 181/182

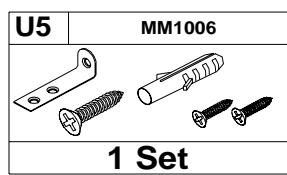
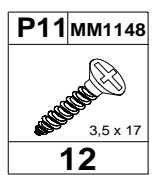
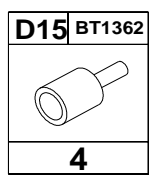
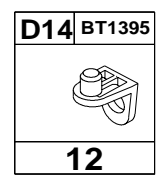

## Type 181

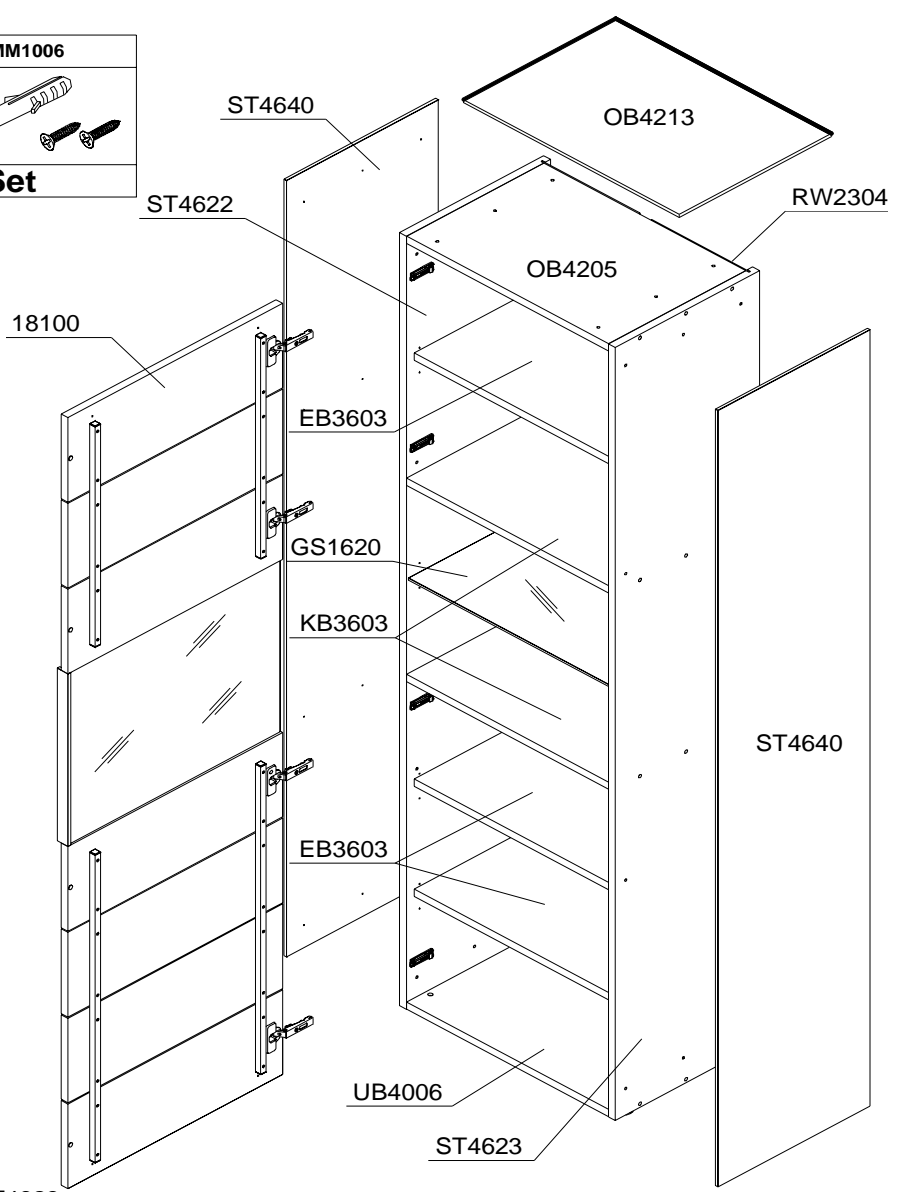

## Type 182

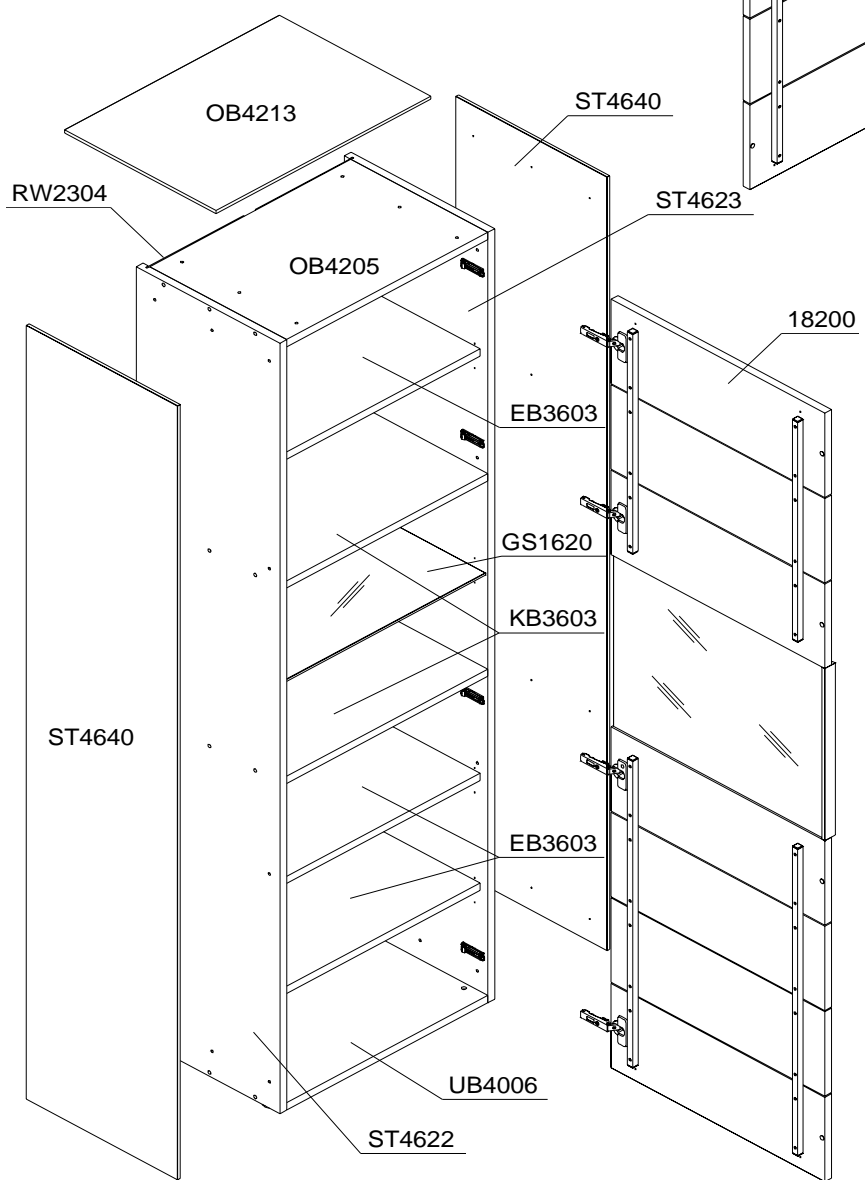

Demontage:  
Dismounting:

1.A.

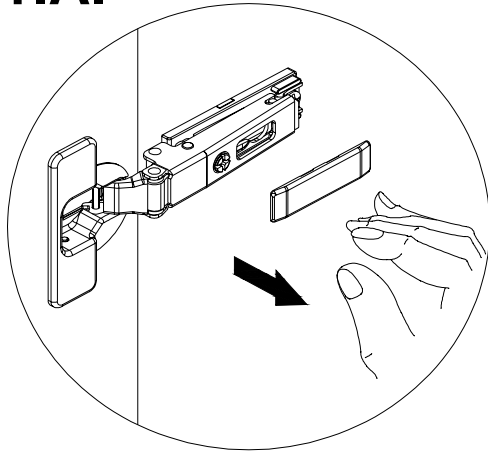

B.

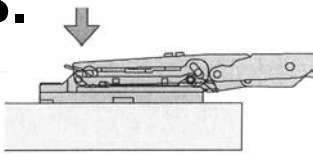

Das Lösen des Bandarmes von der Montage  
Druck auf die beiden mit Pfeil bezeichneten

C.

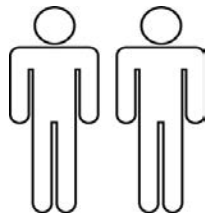
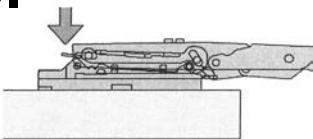

Type 181  
+  
Type 182

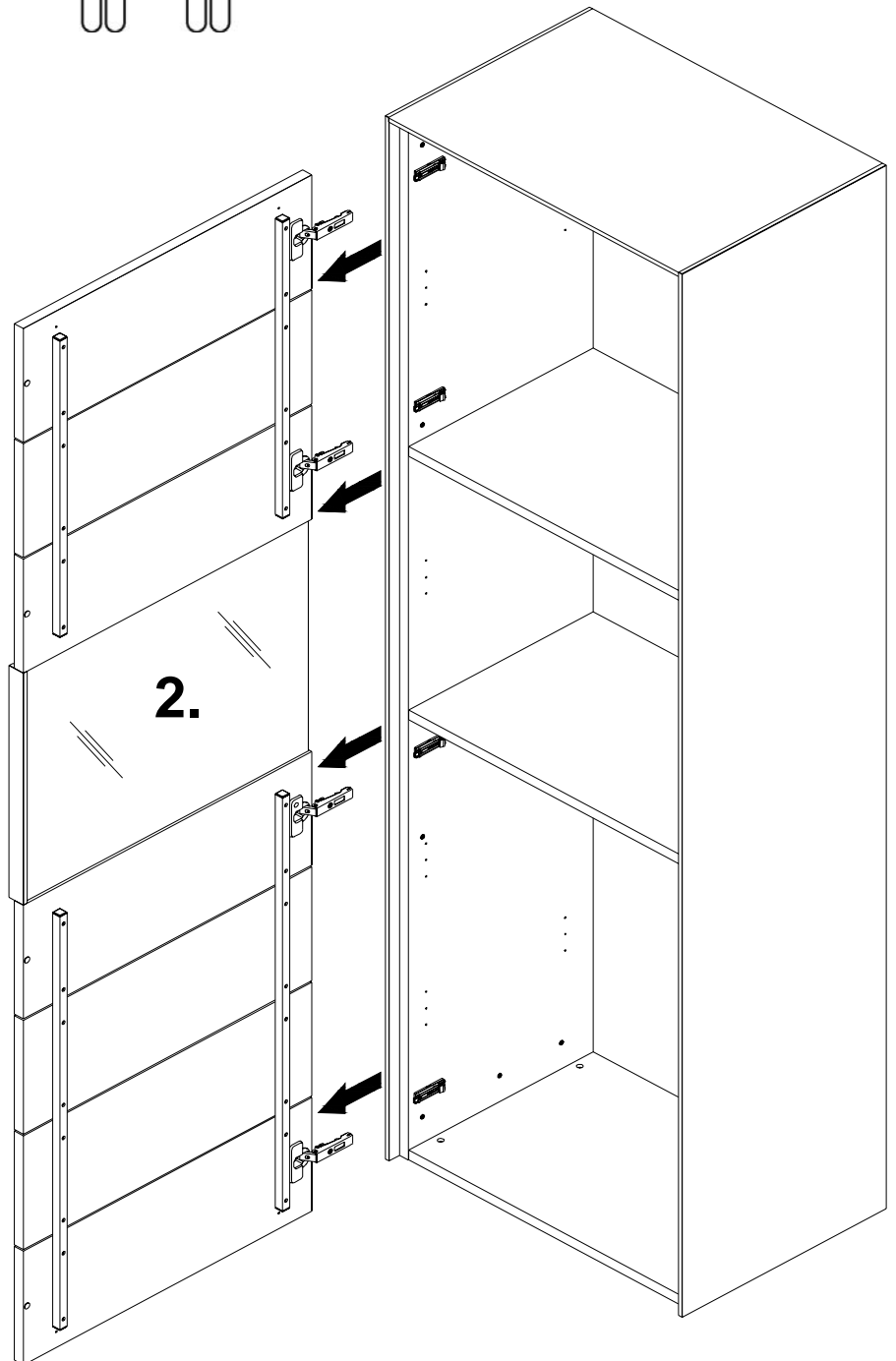

**Achtung Bruchgefahr:  
Immer vor Durchbiegung  
schützen !**

**Always protect from  
bending: Warning Danger  
of breakage !**

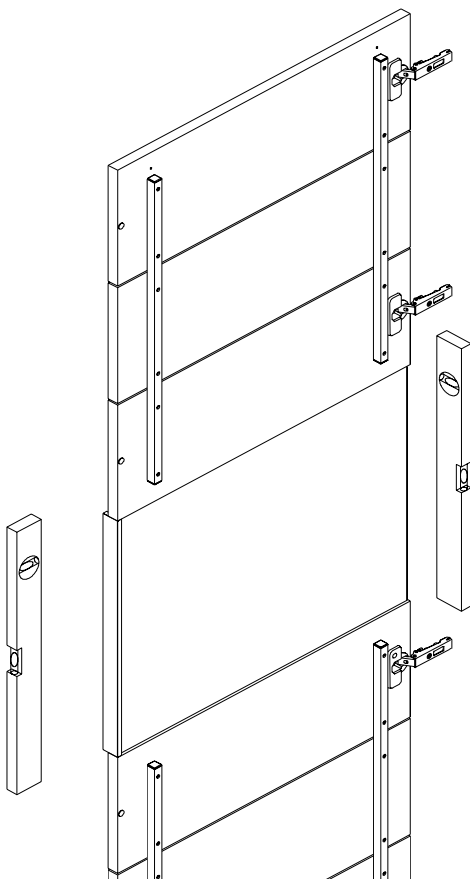
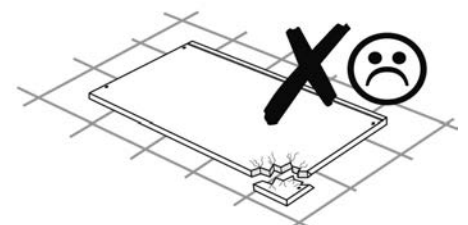
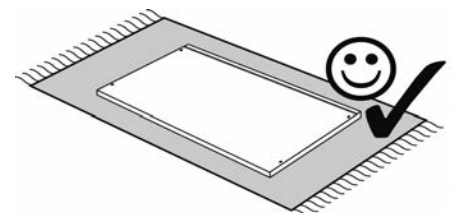

**Type 181**

**+**

**Type 182**

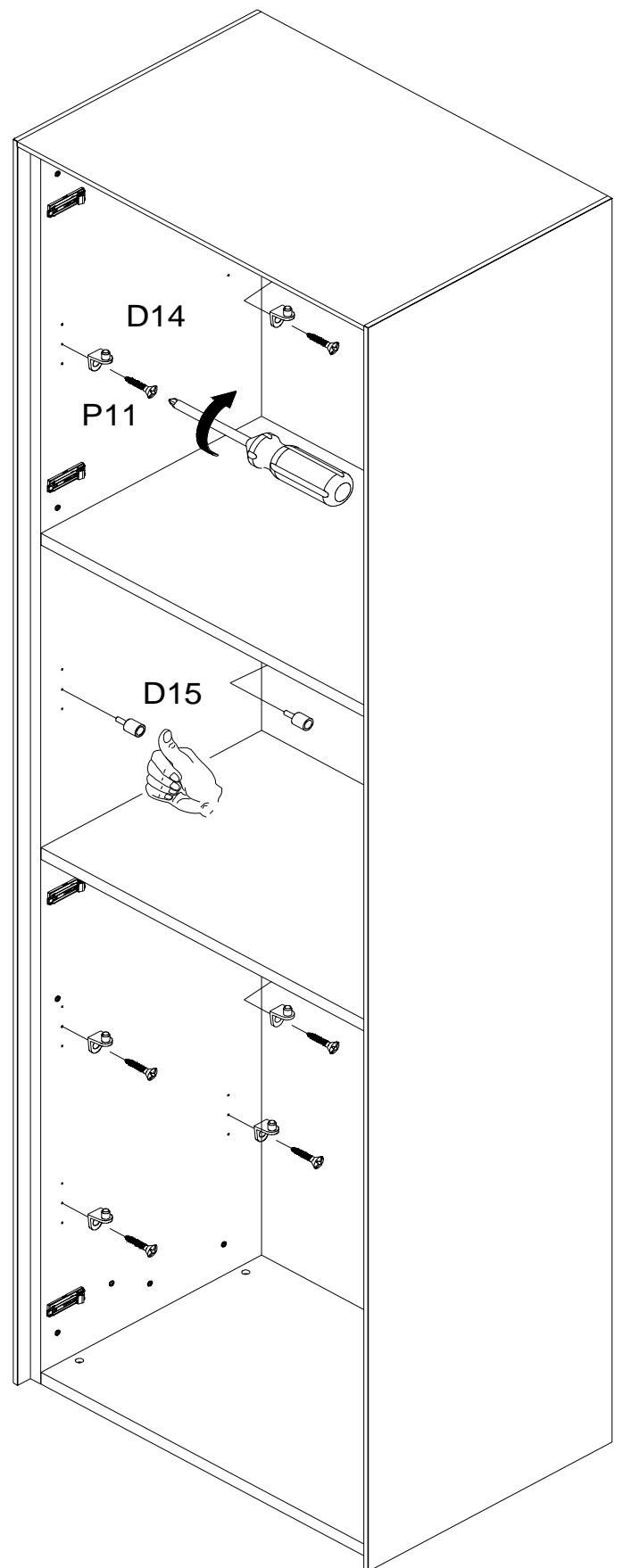
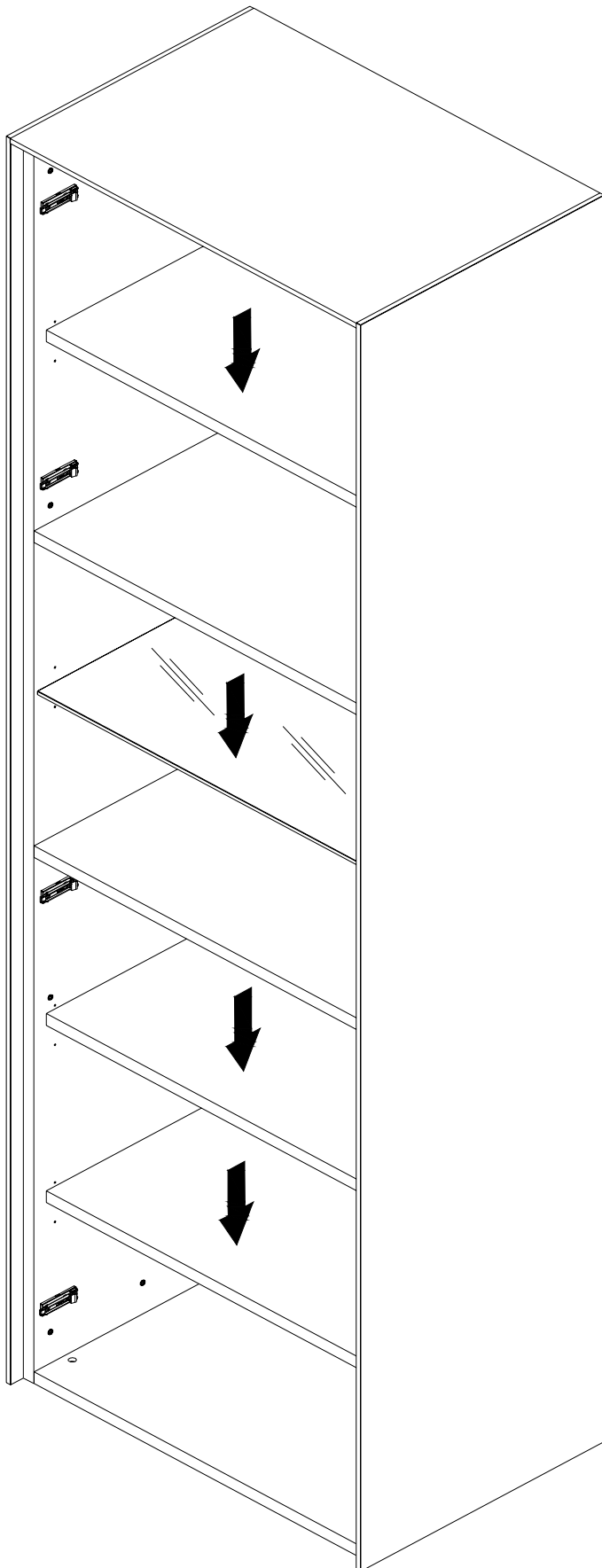

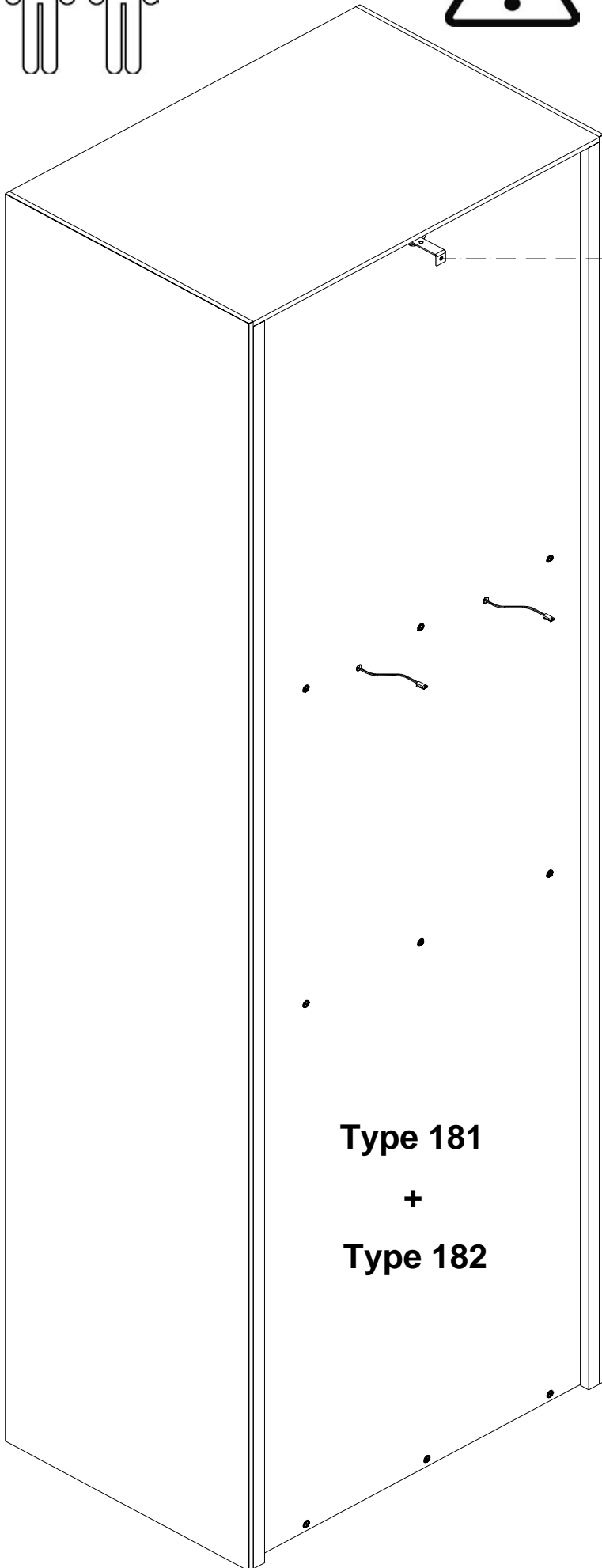
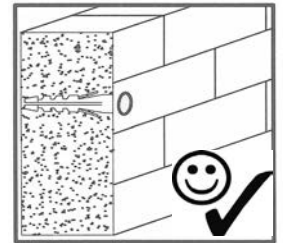
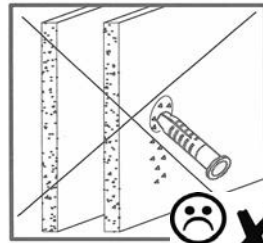
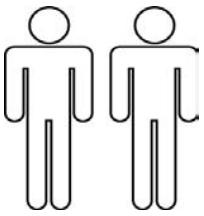

**Type 181  
+  
Type 182**

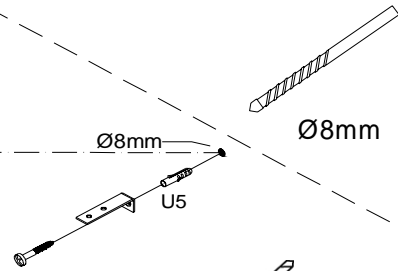

Ø8mm

Ø8mm

U5

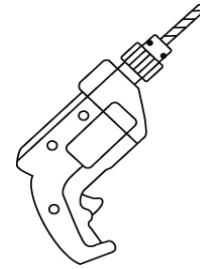

**Beleuchtung  
ist optional !**

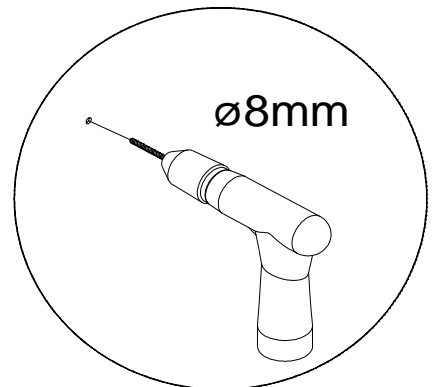

Ø8mm

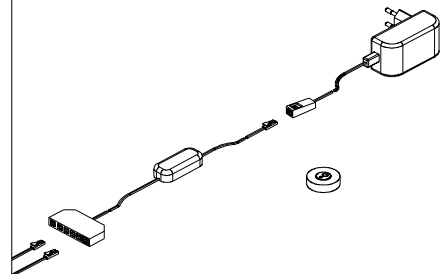
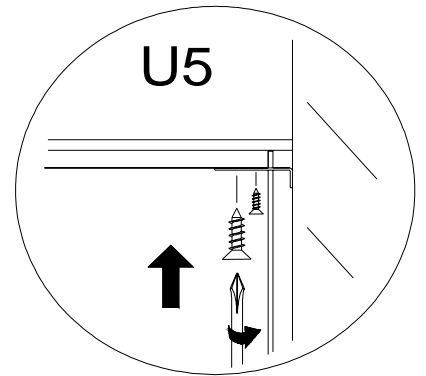
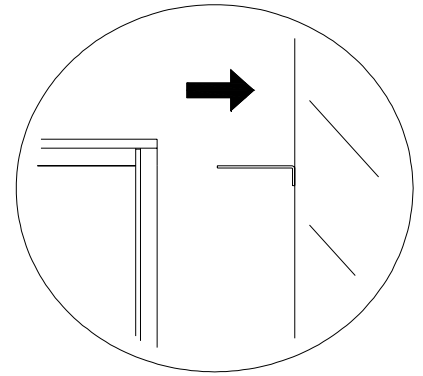
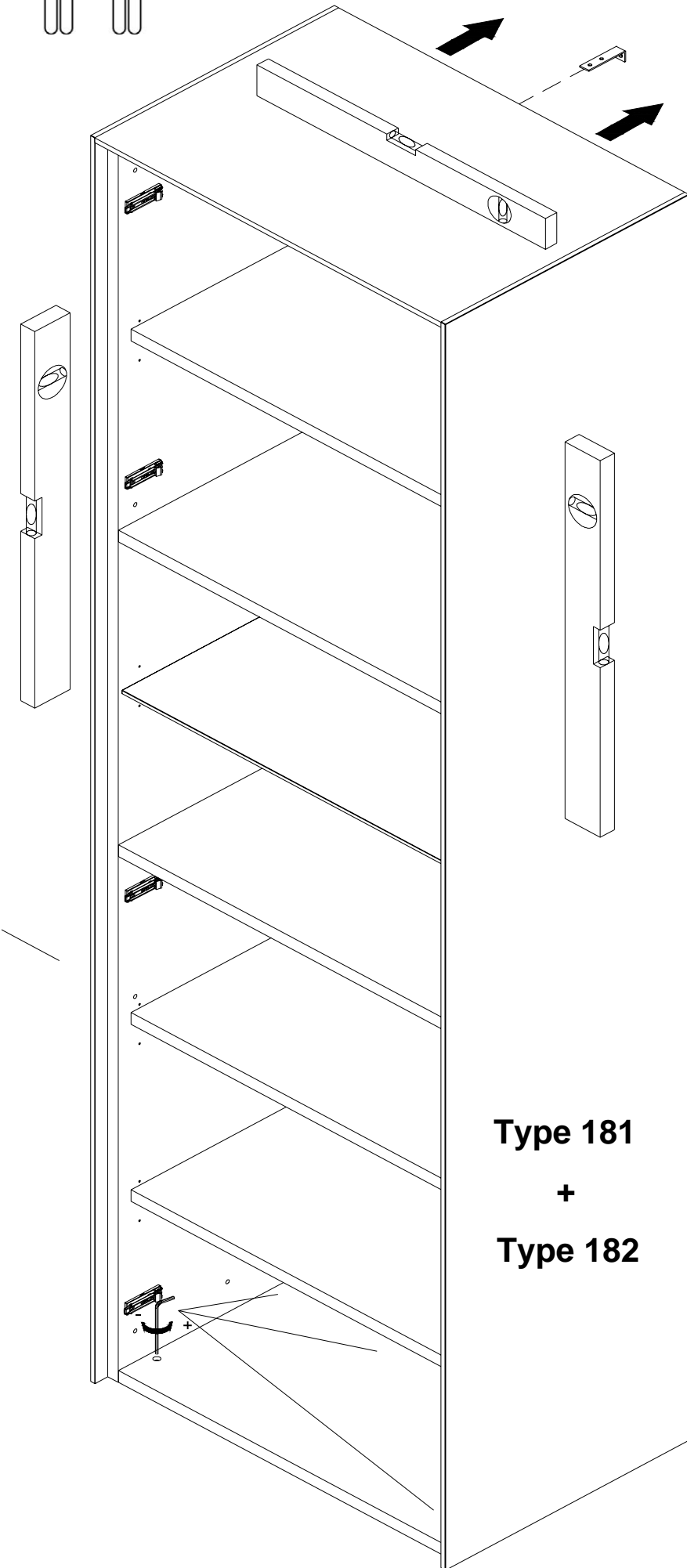
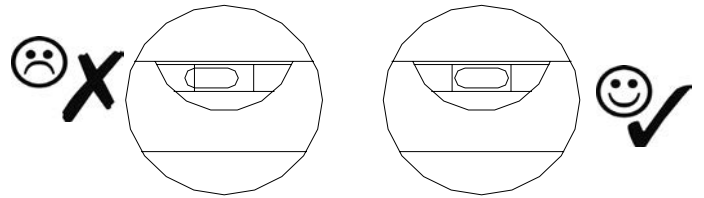
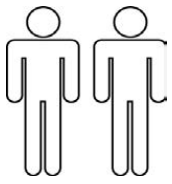

**Beleuchtung ist optional !**



**Type 181  
+  
Type 182**

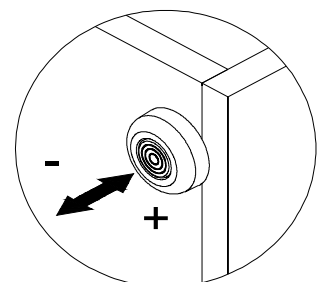
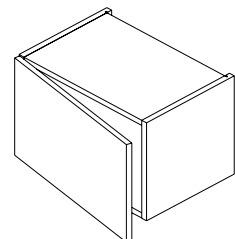

# Montage: Assembly:

Die beiden mit Pfeil bezeichneten Punkte in

## 2. A.

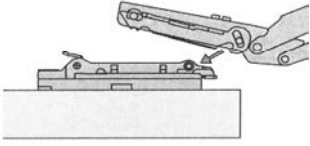

Eine leichte Drehung ausführen

## B.

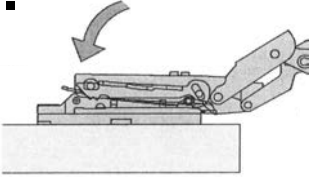

und leicht andrücken.

## C.

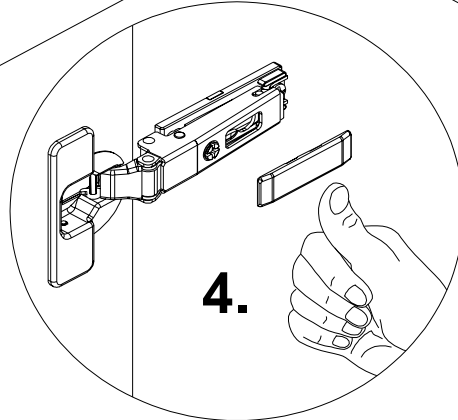
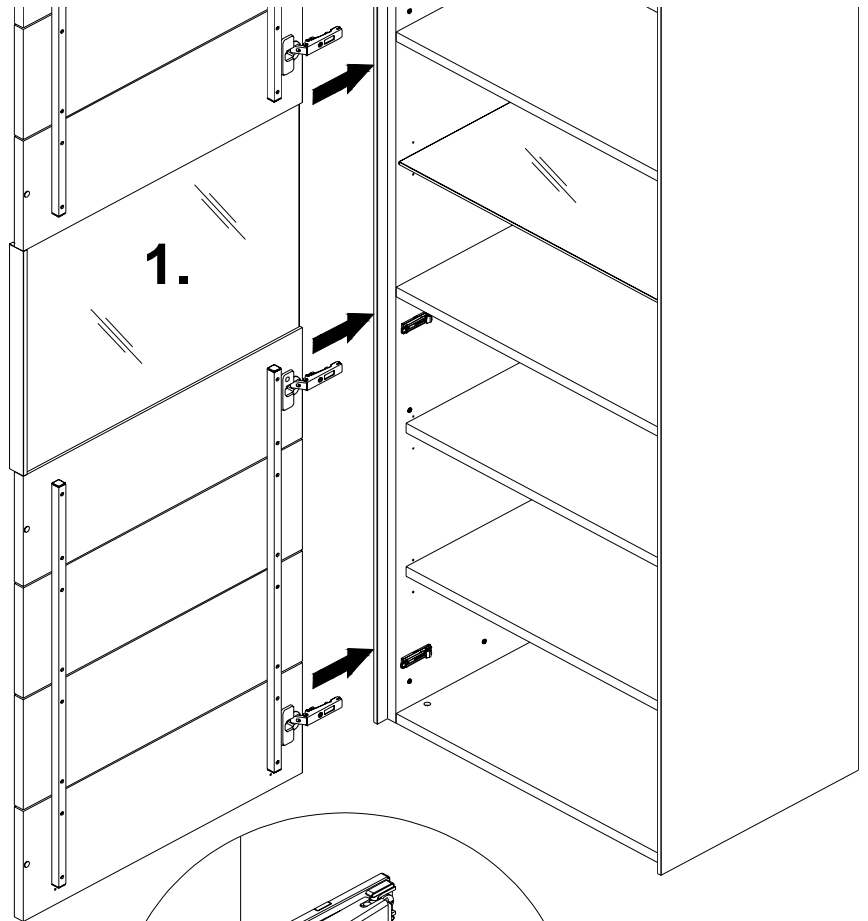
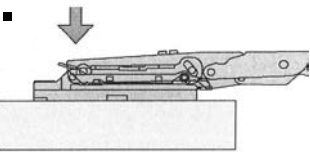

Type 181  
+  
Type 182

## 3.

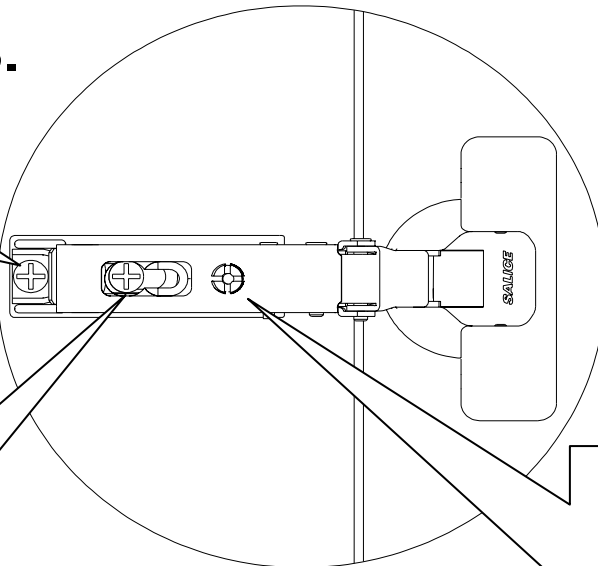

Verstellung der Tür:  
Adjustment of the door:

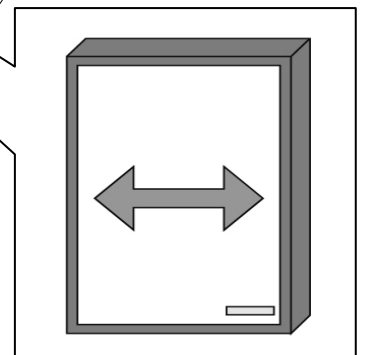
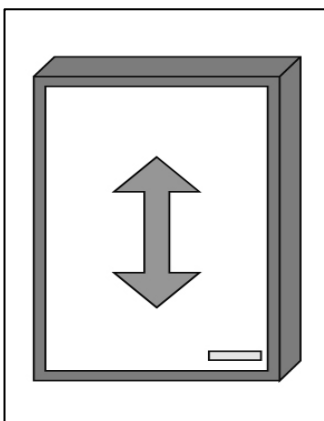
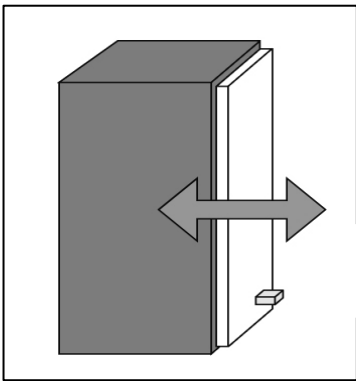

# Q-Media

Couchtisch  
Couchtable



**Type 620**

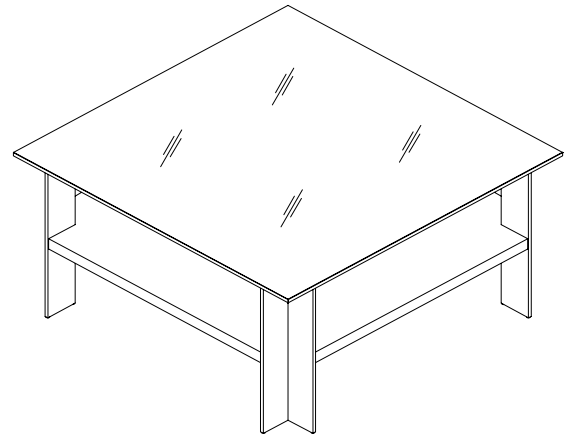

**Type 621**

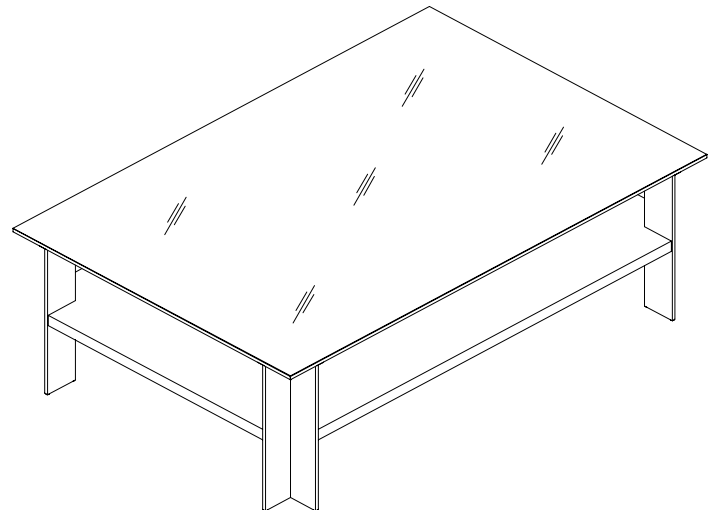

**Beschlag / Fitting / Montaža / Felszerelés / Montaj / Vybavení / Vybavenie /  
Ugradnja / Фитинги / Uydurma / Adattamento:**

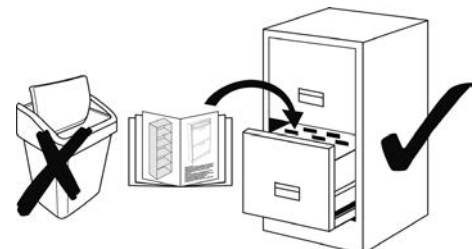
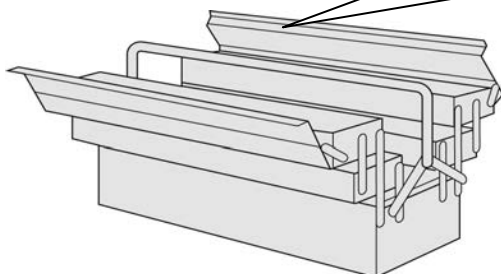
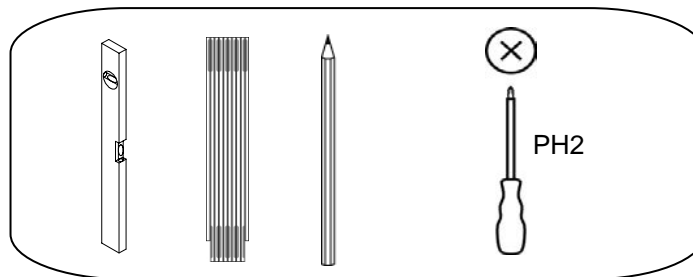
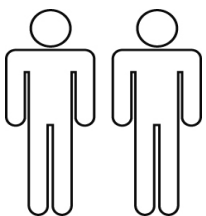

## Type 620

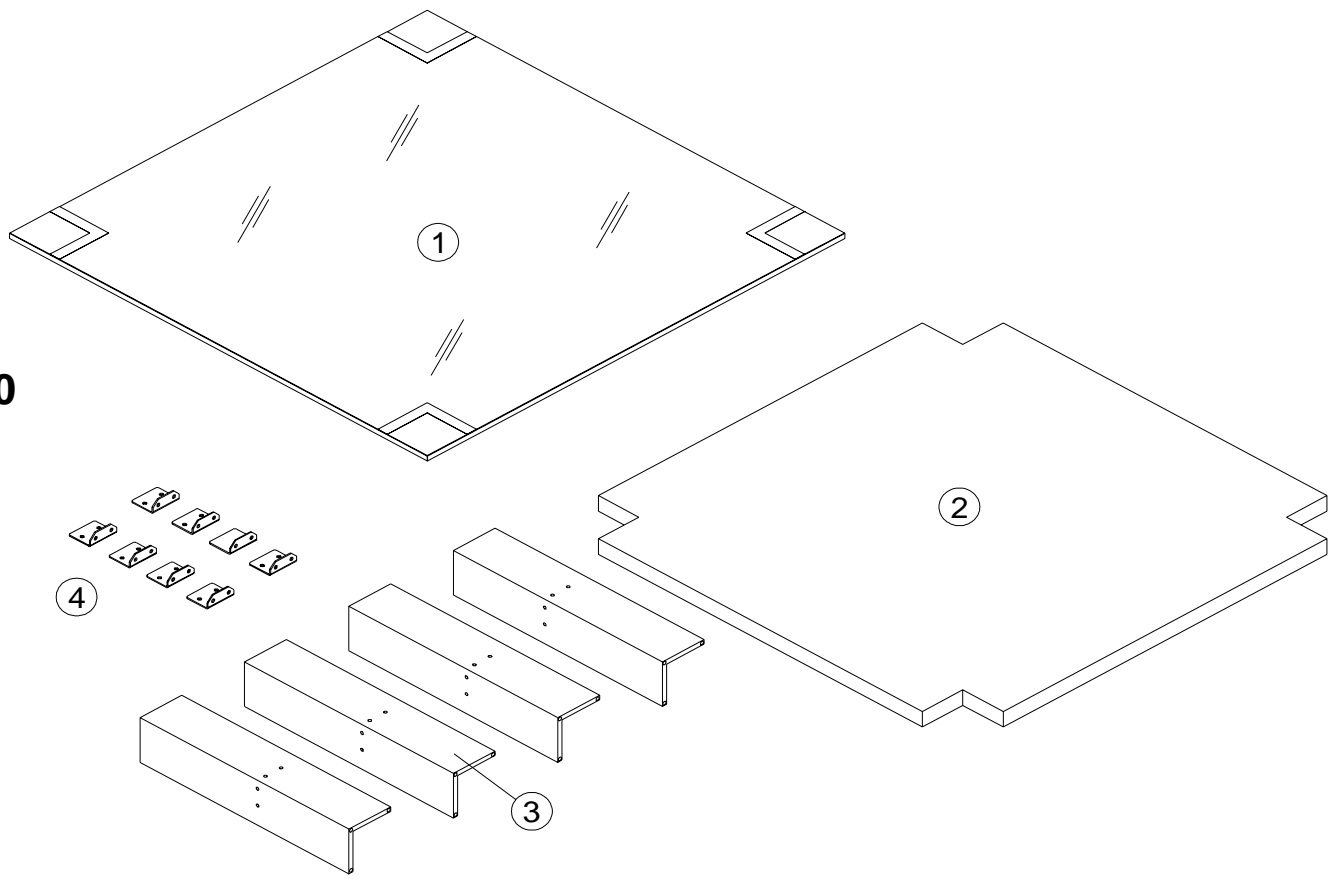

## Type 621

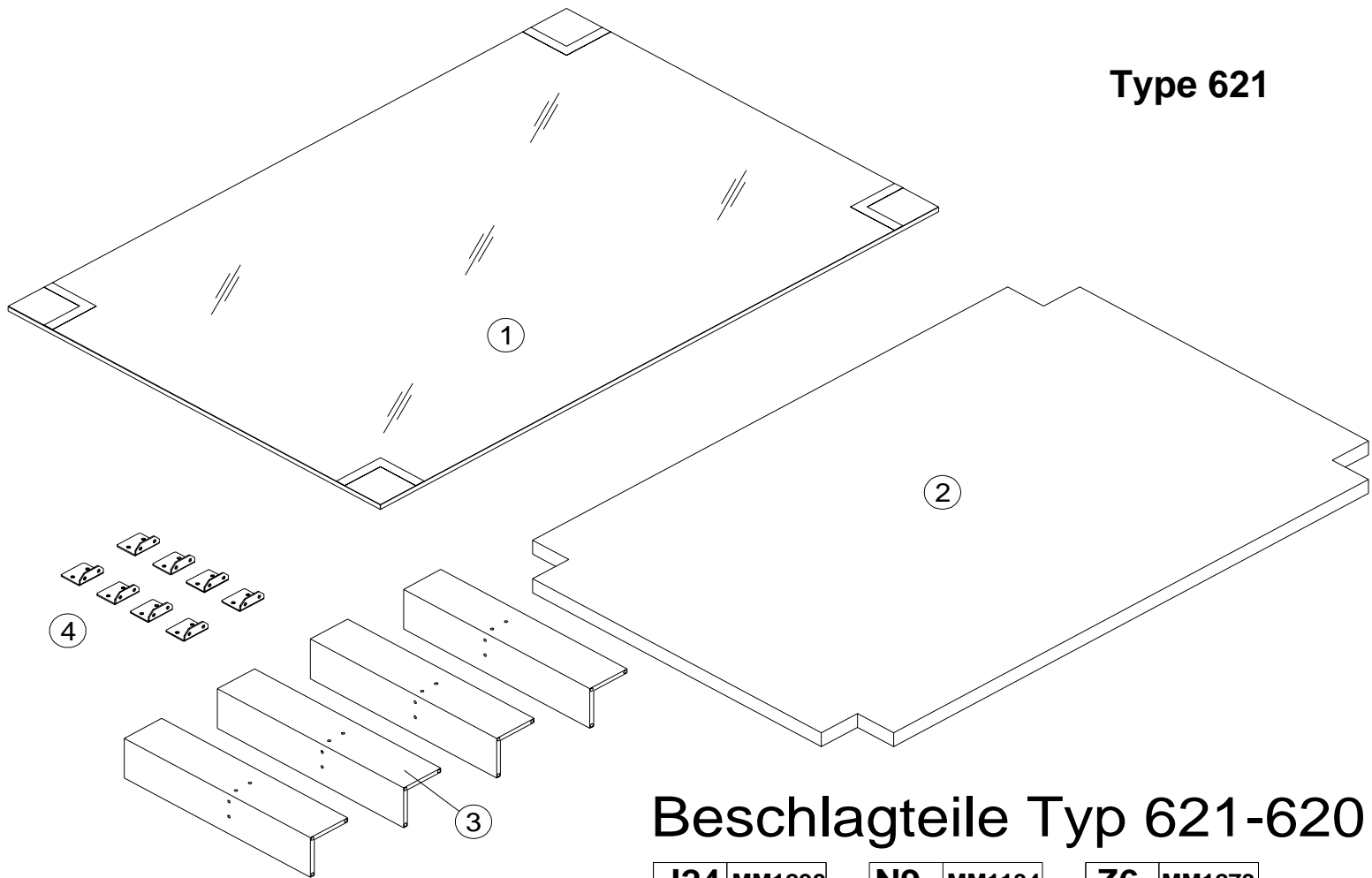

## Beschlagteile Typ 621-620

<b>J24</b>	<b>MM1290</b>
 M5 x 8	
<b>16</b>	

<b>N9</b>	<b>MM1134</b>
 4,0 x 15	
<b>16</b>	

<b>Z6</b>	<b>MM1273</b>
	
<b>24</b>	



Type 621 /  
620

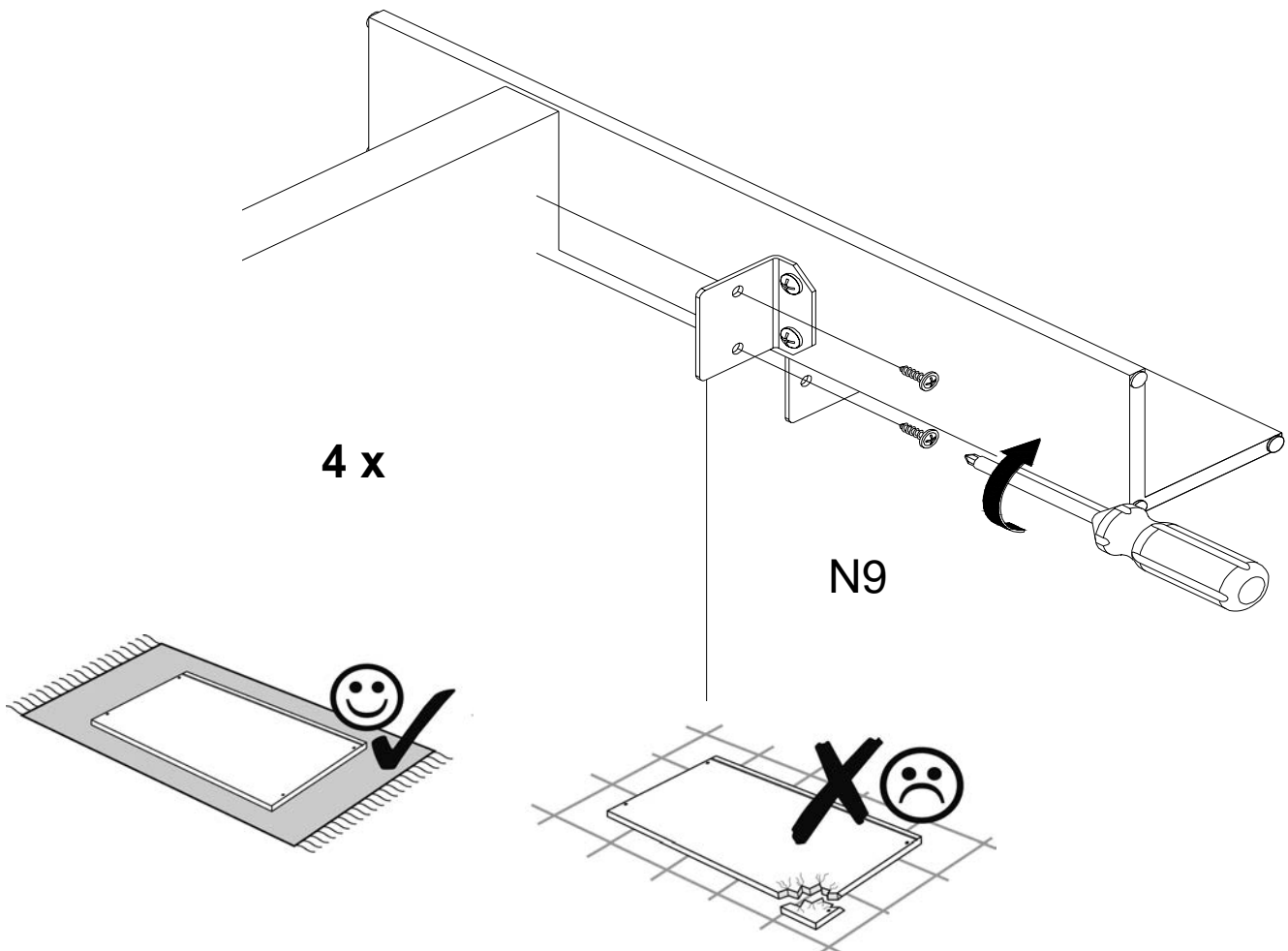
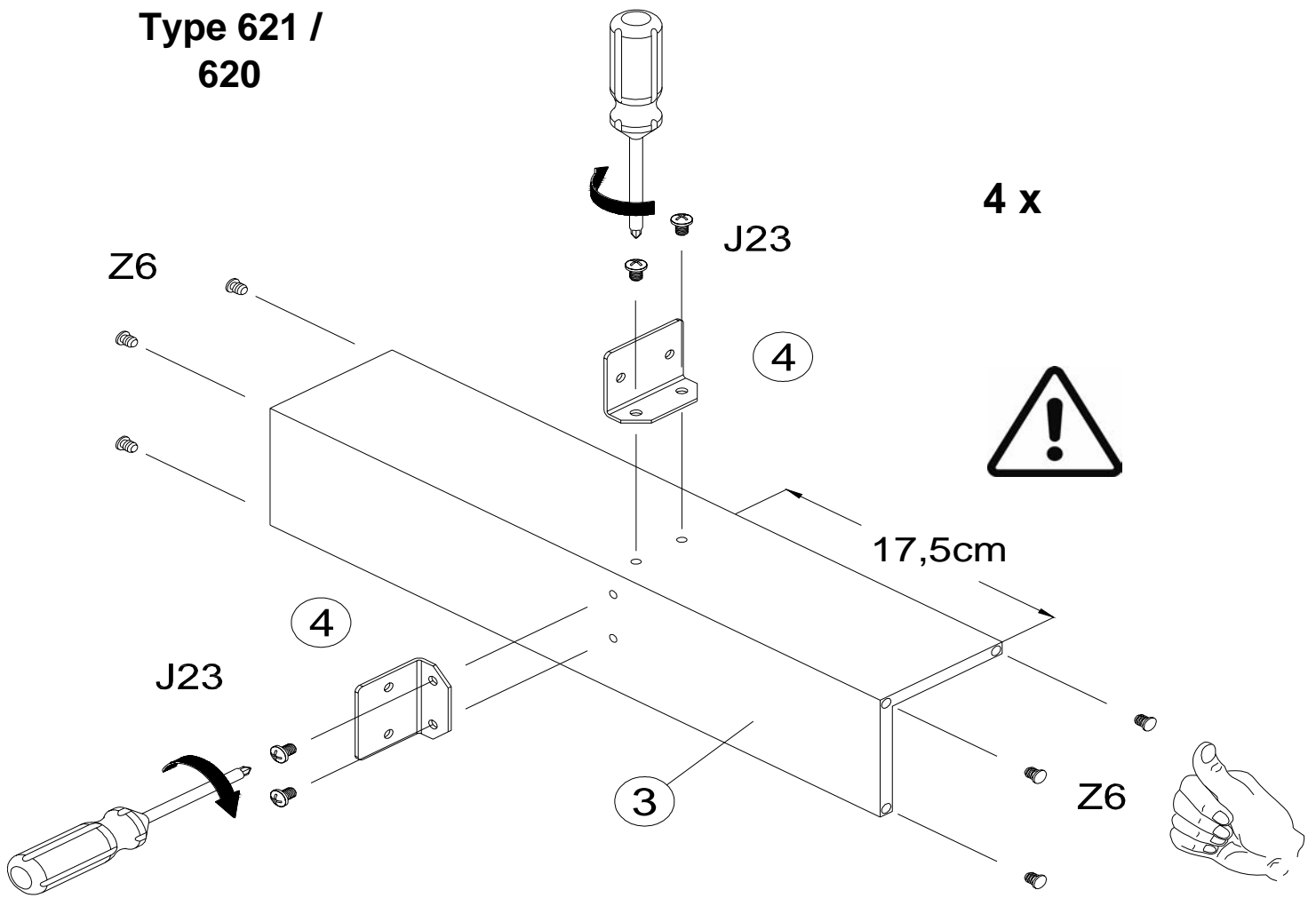

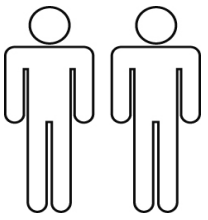

# Type 621

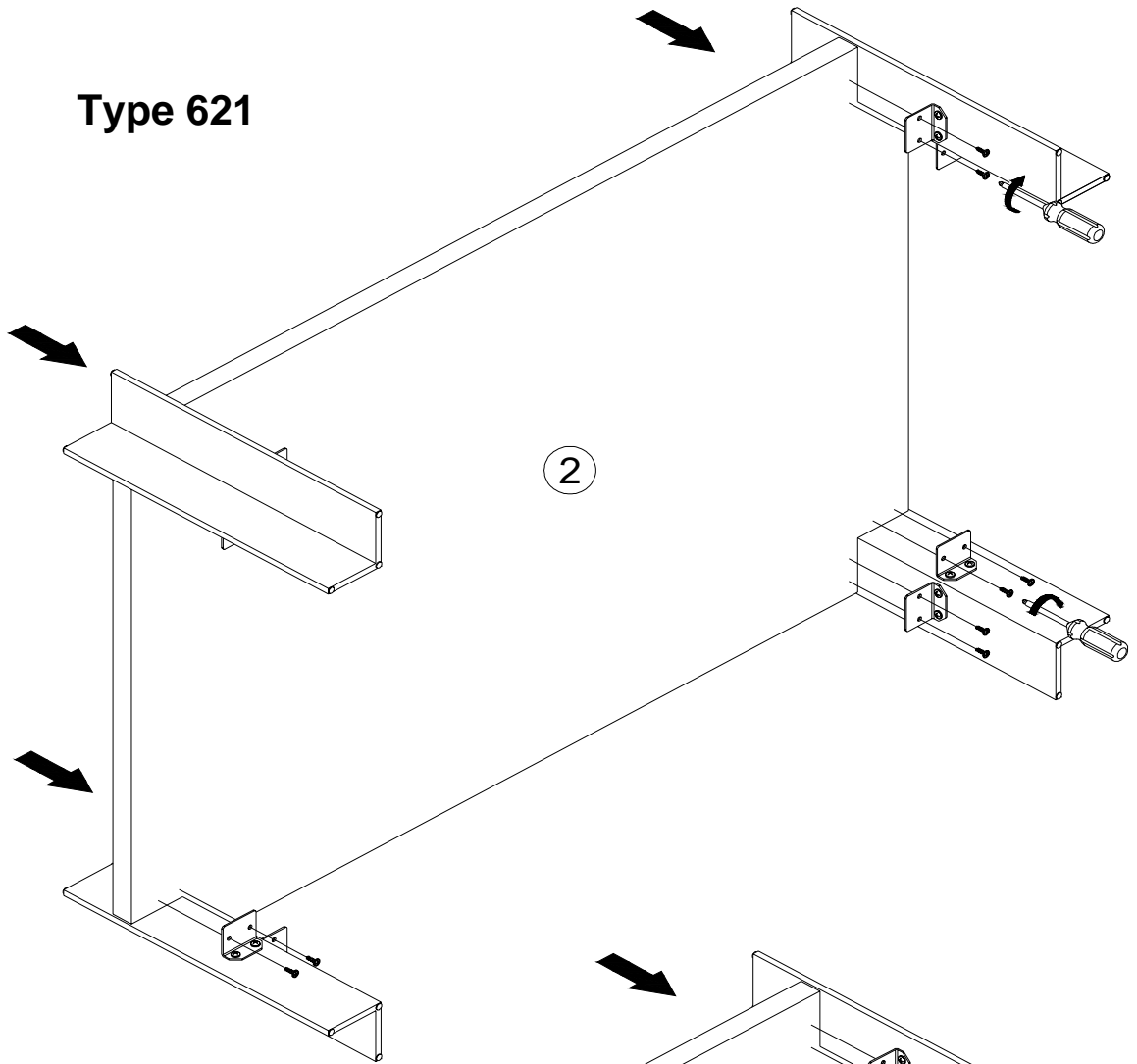

# Type 620

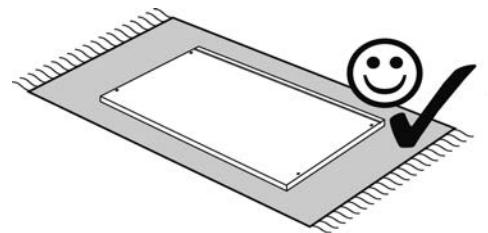
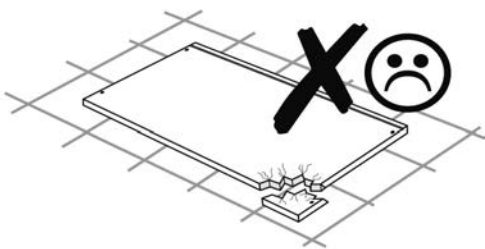
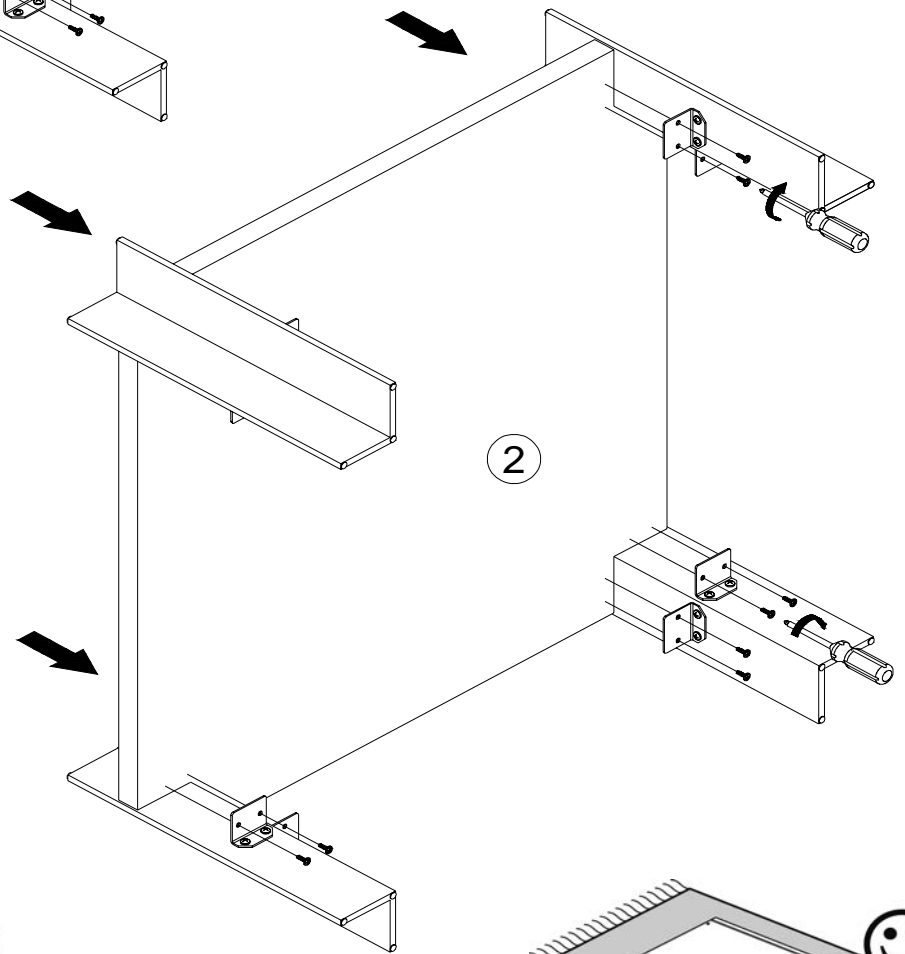

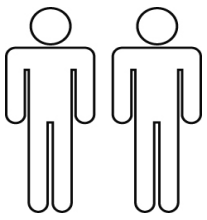

# Type 621

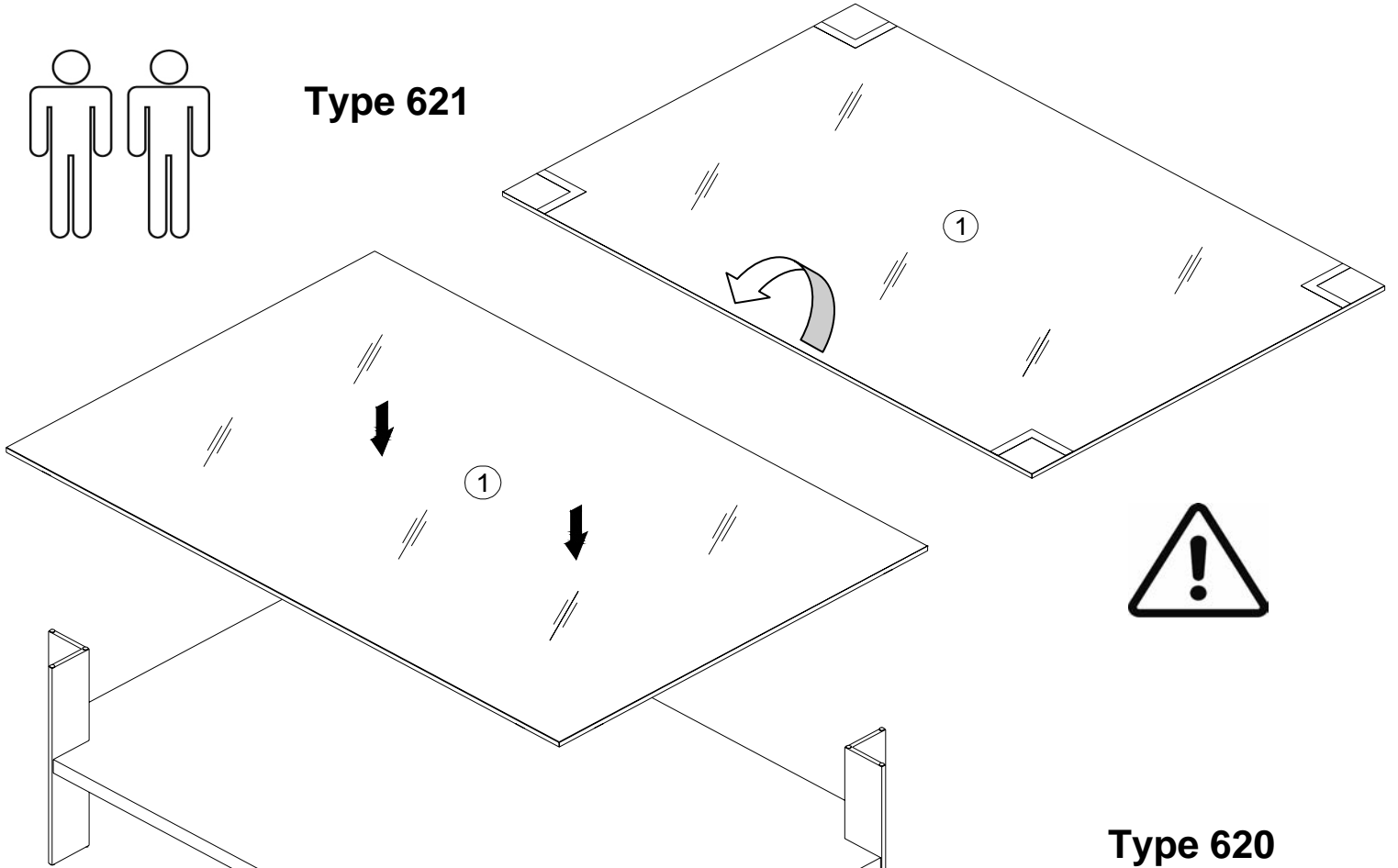

# Type 620

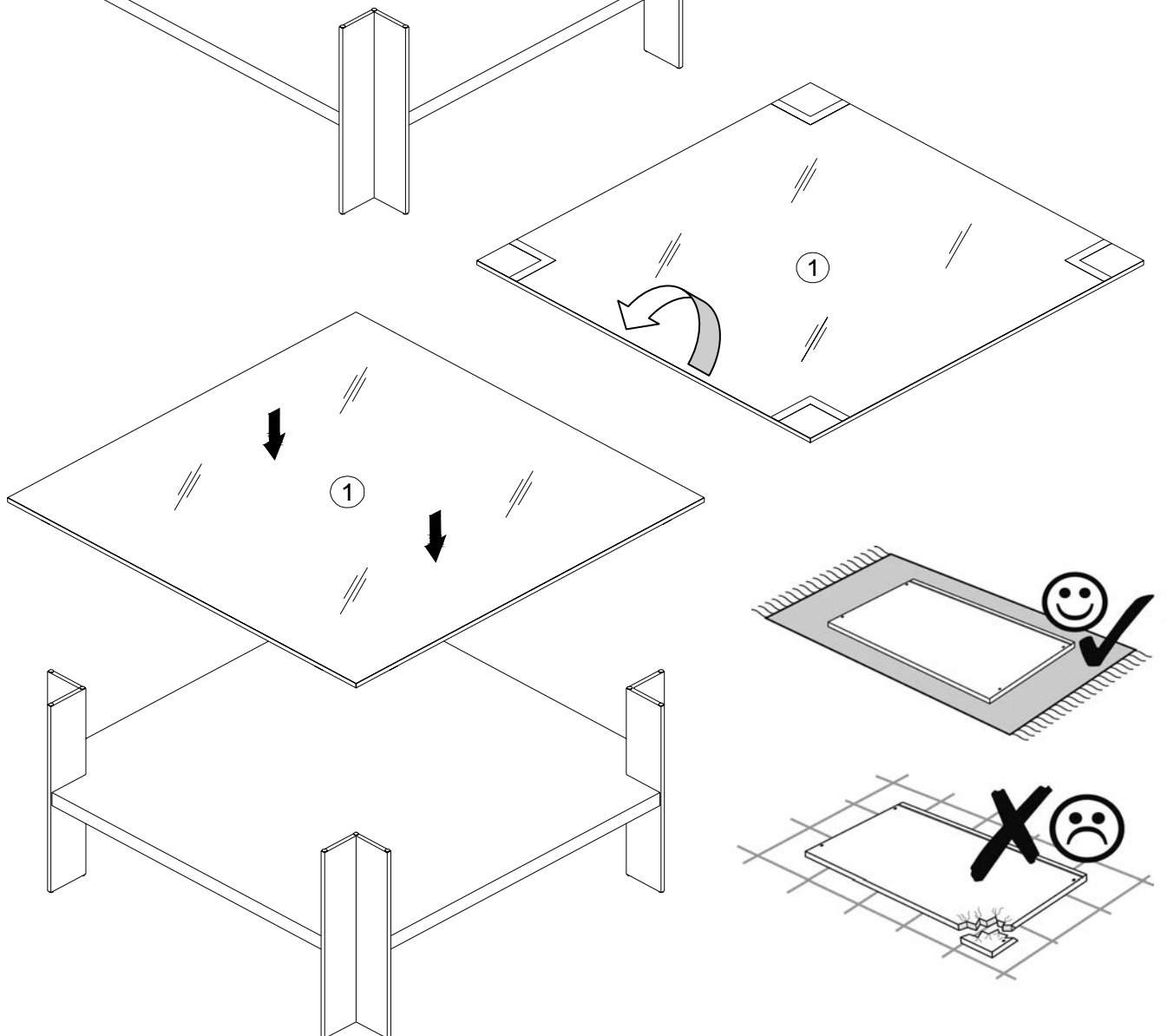

# Q-Media



## Musterring

### Hängeböden

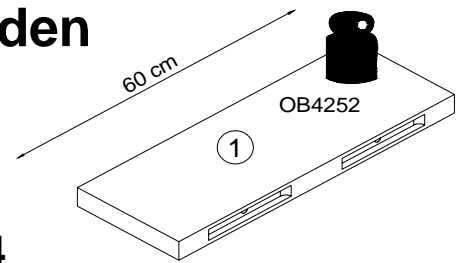

Type 624

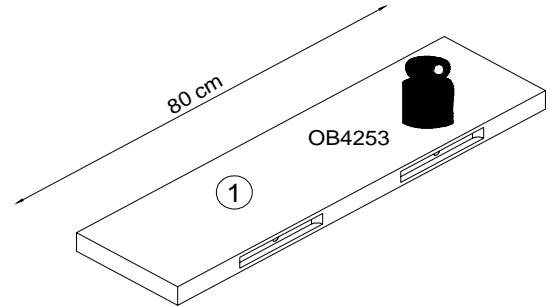

Type 625

2 x Beschlag-  
Set BB4429



max. 5kg

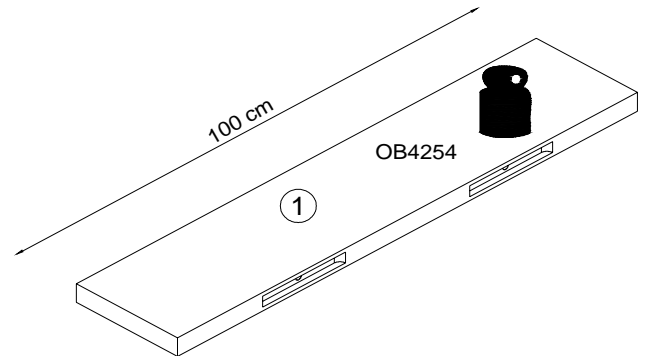
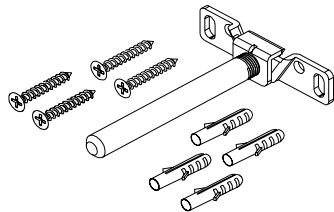

Type 626

Sehr geehrte Kundin, sehr geehrter Kunde,

Das beigefügte Wandbefestigungsmaterial (Dübel und Schrauben) eignet sich nur für festes Mauerwerk (z.B. Beton- oder Ziegelwände). Für andere Wandaufbauten sind eventuell Spezialdübel und andere Schrauben notwendig. Ziehen Sie gegebenenfalls eine Fachkraft zurate. Technische Änderungen vorbehalten.

Dear customer,

the provided mounting material (dowels and screws) can only be used with solid masonry (e.g. concrete or brick walls). For other wall constructions special dowels and screws are needed. Please consider an expert in these cases. Leaving technical changes.

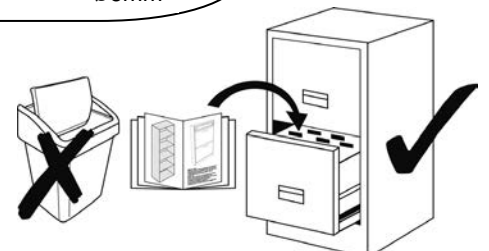
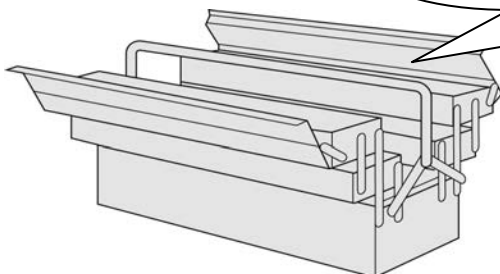
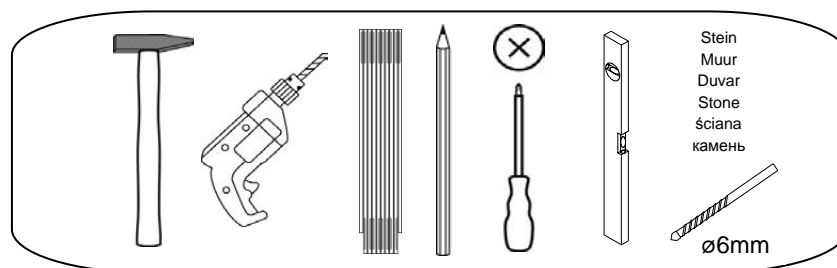
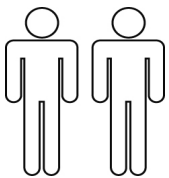

## Bohrungen markieren Mark boreholes

### Type 624

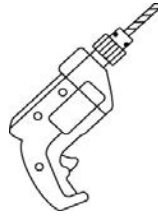
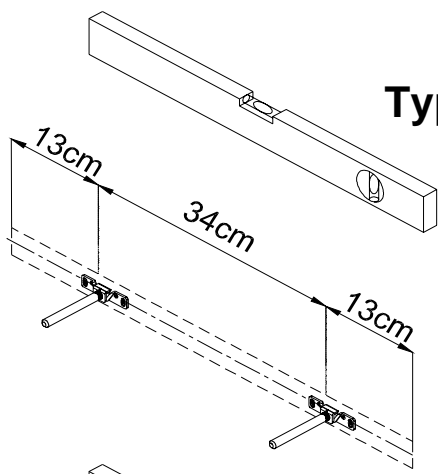

Das mitgelieferten Dübel und Schrauben sind nur für Massivwände geeignet.

Bitte vor der Montage die Wand auf ihre Eigenschaften überprüfen.

The provided mounting material (dowels and screws) can only be used with solid masonry

(e.g. concrete or brick walls). For other wall constructions special dowels and screws are needed.

### Type 625

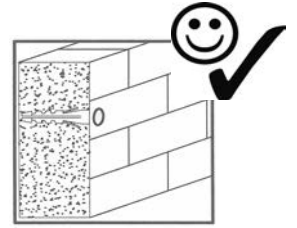
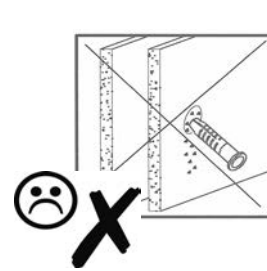
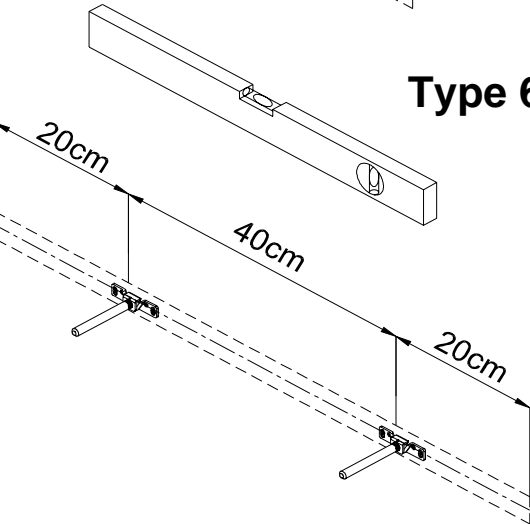

### Type 626

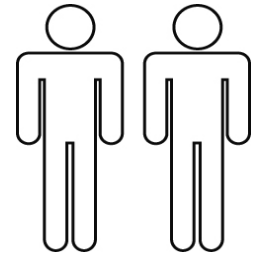
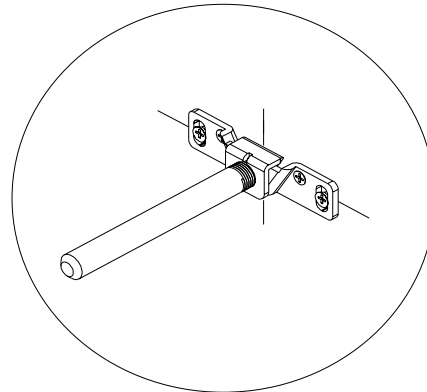
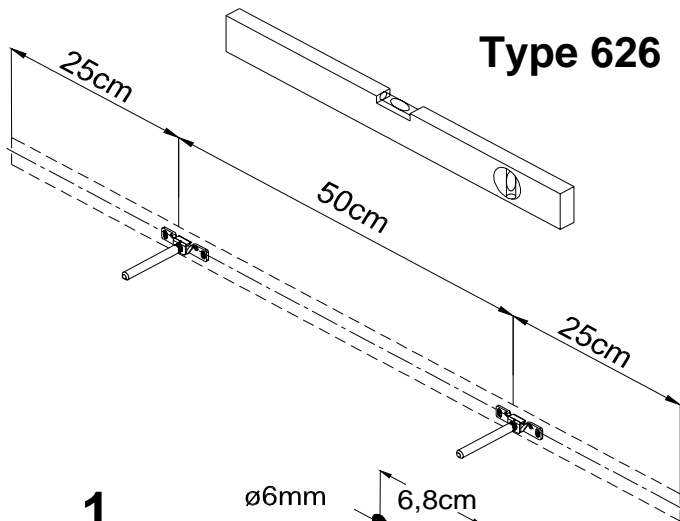

1.

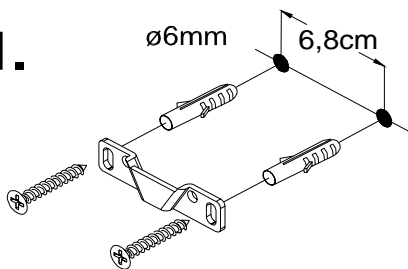

2.

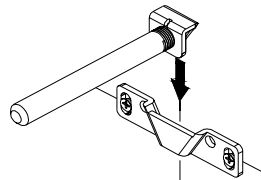

Verstellung:  
Adjustment:

3.

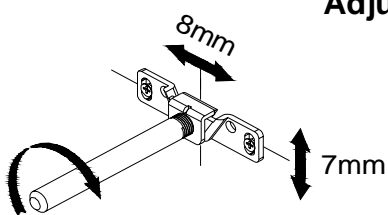

4.

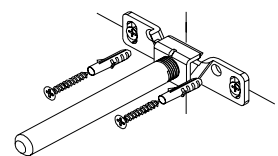

Neigungsverstellung:  
Angle adjustment:

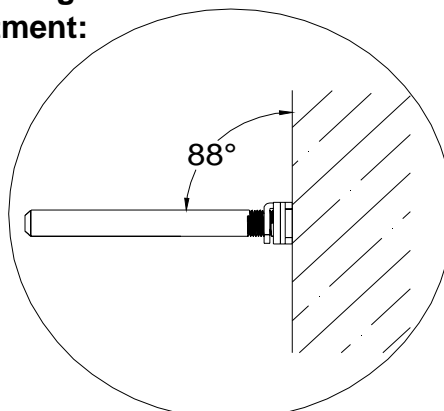

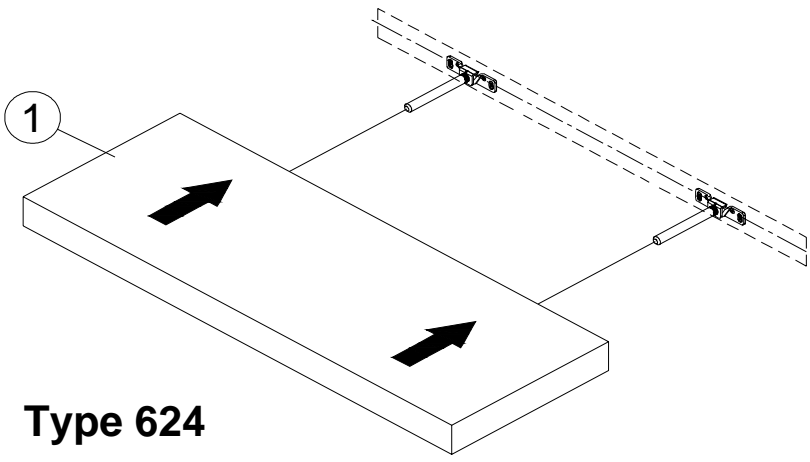

**Type 624**

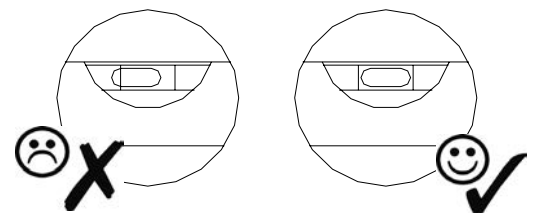

**Die max. Belastung des Steckbodens beträgt 5kg.  
Die Last auf der gesamten Breite des Bodens verteilen.  
Keine Punktlast.**

**The maximum load of the shelf is 5kg.  
The load needs to be deployed on the whole width of the shelf. No point load.**

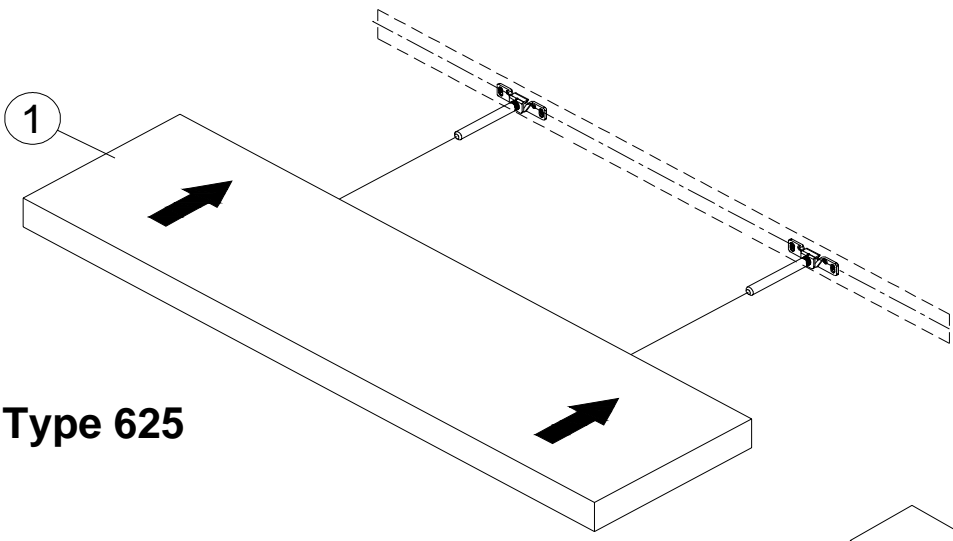

**Type 625**

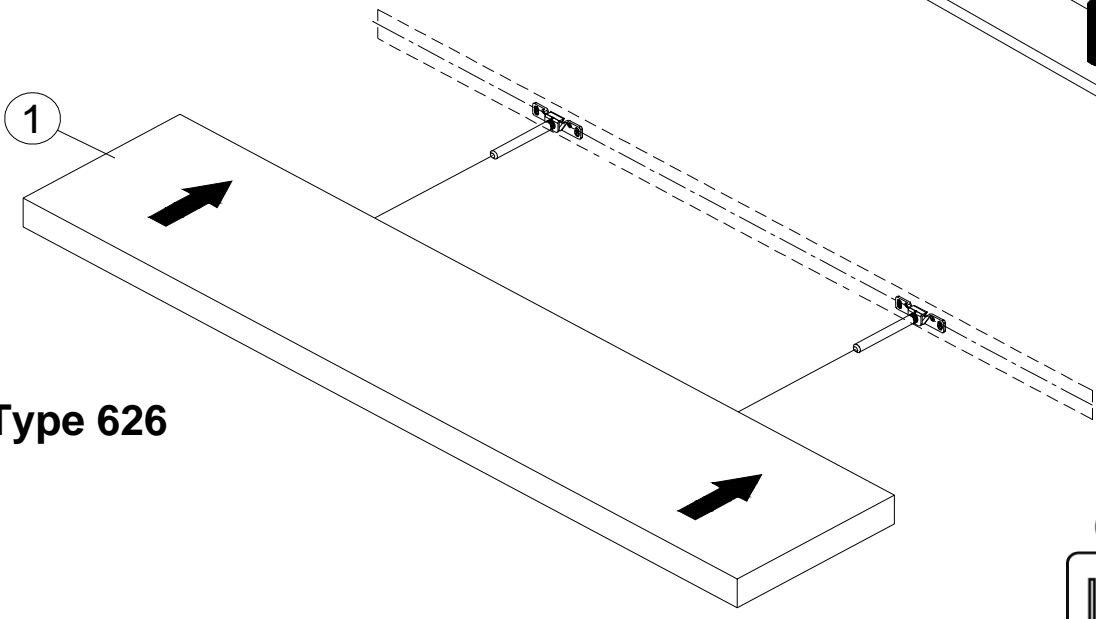
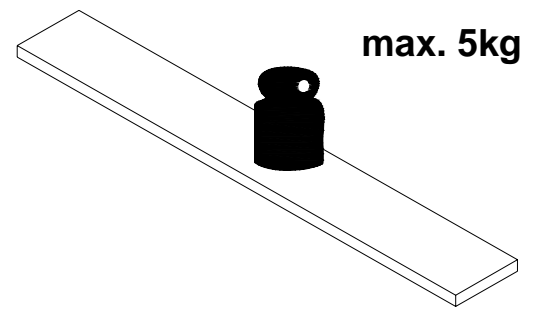

**Type 626**

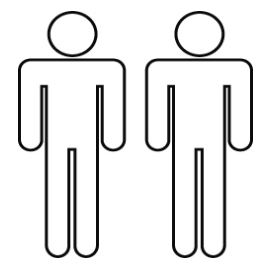

# Q-Media

## TV-Halterung Fullmotion

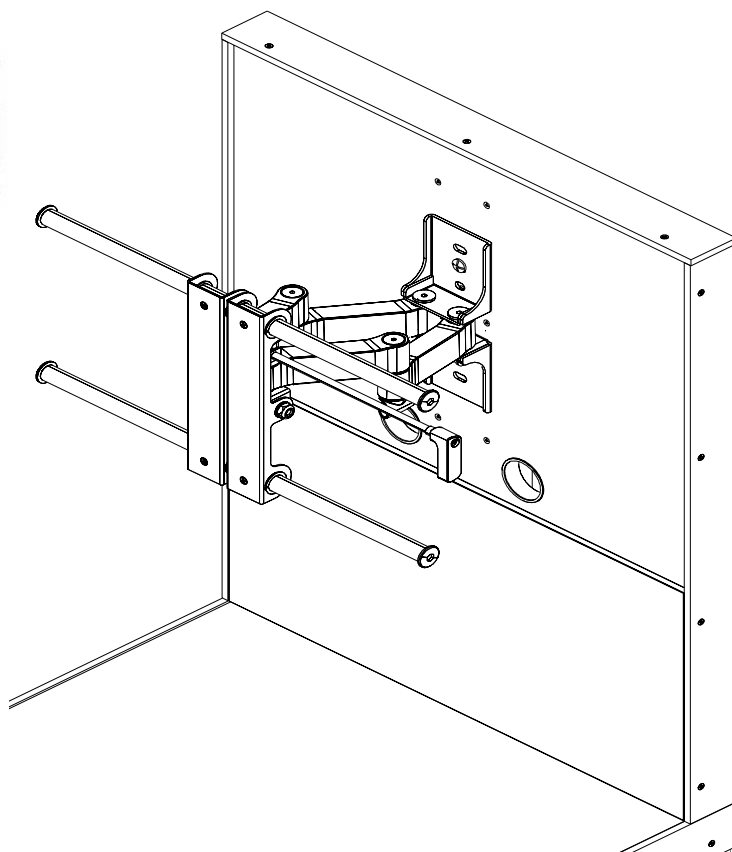

Beschlag / Fitting / Montaža / Felszerelés / Montaj / Vybavení / Vybavenie /  
Ugradnja / Фитинги / Uydurma / Adattamento:

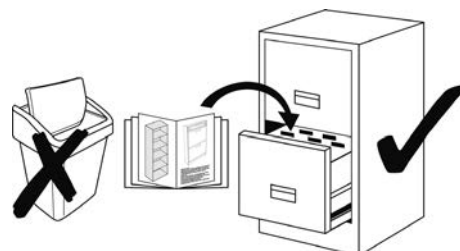
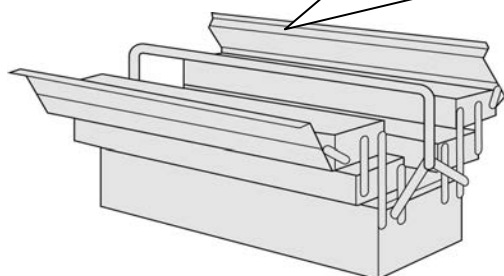
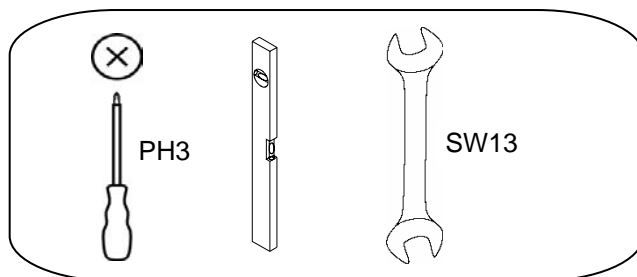
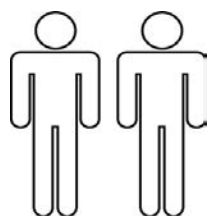
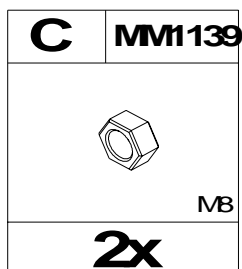
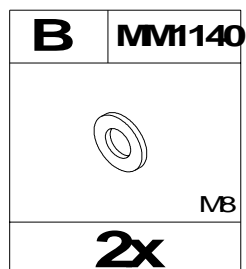
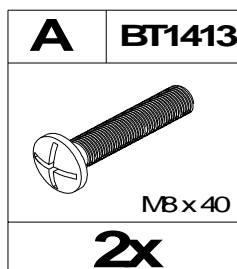

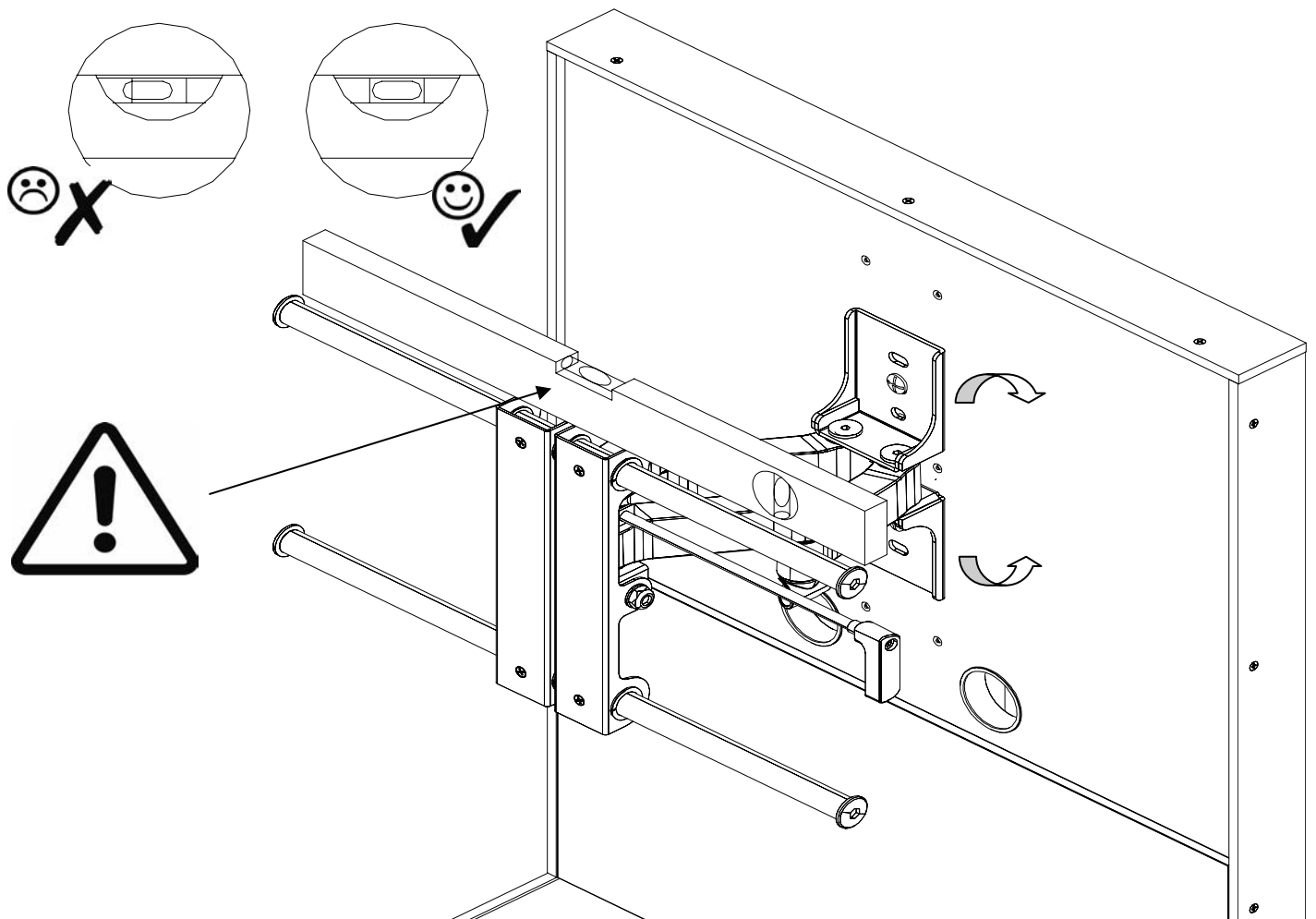
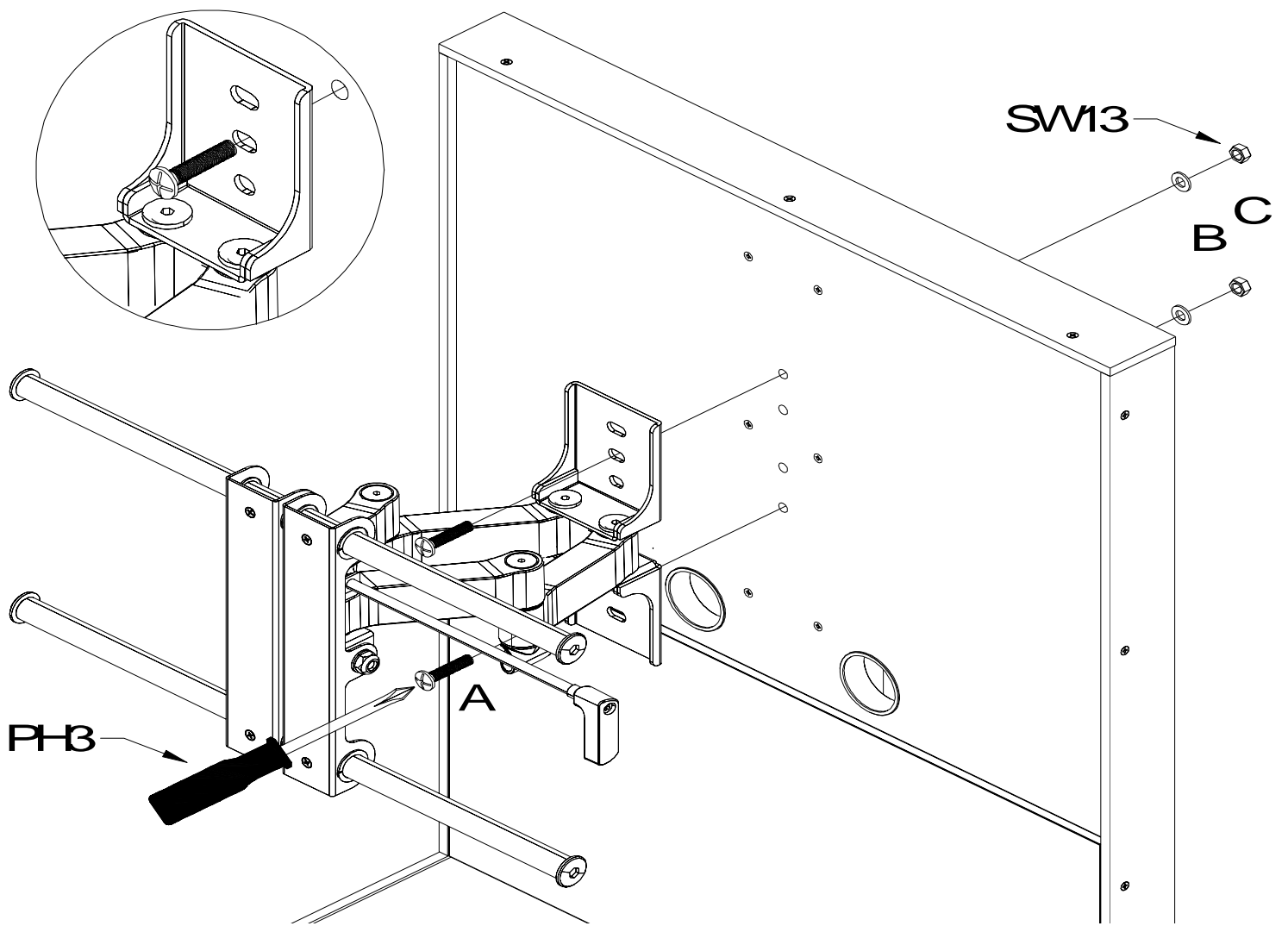



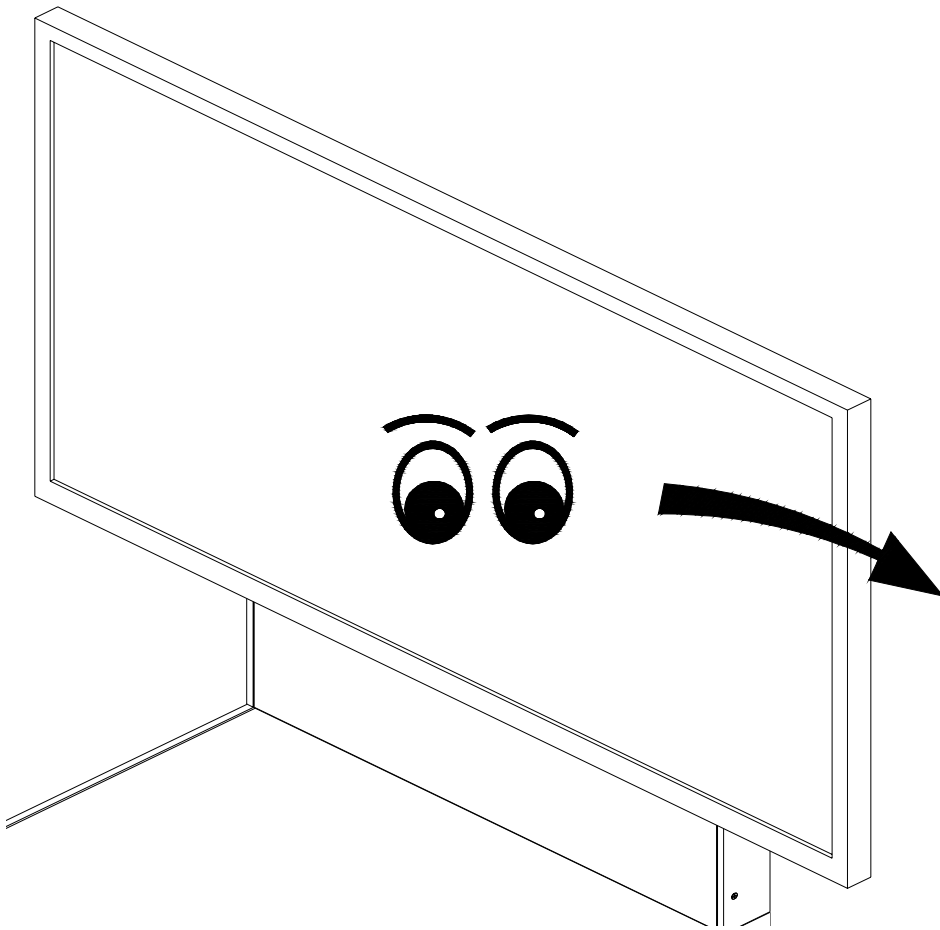

**TV Wandhalterung**  
**TV Wall Bracket**



**00108730**  
**00108744**

# Q-Media

## TV-Halterung starr

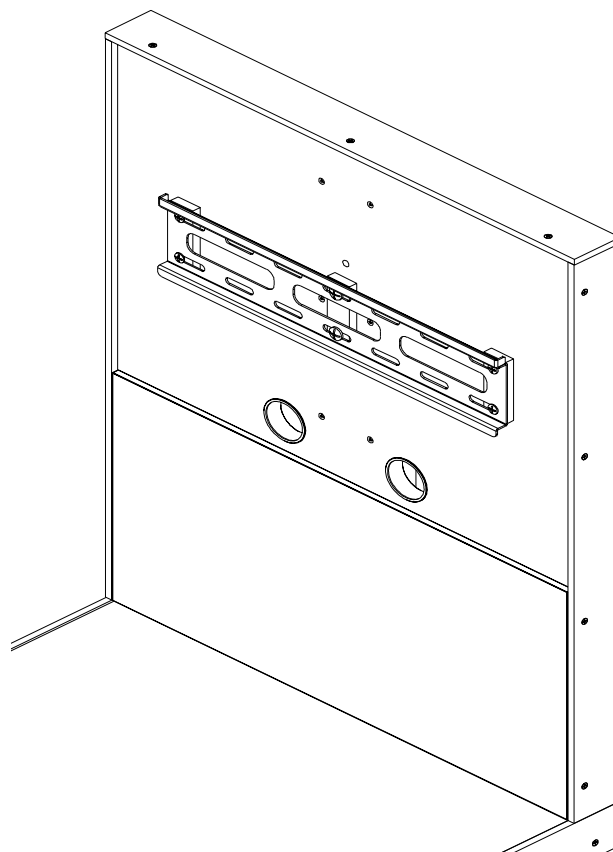

Beschlag / Fitting / Montaža / Felszerelés / Montaj / Vybavení / Vybavenie /  
Ugradnja / Фитинги / Uydurma / Adattamento:

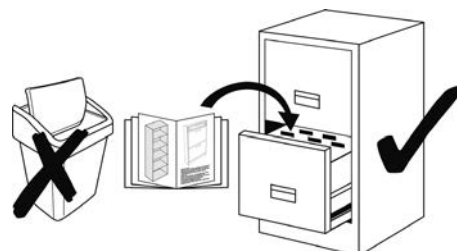
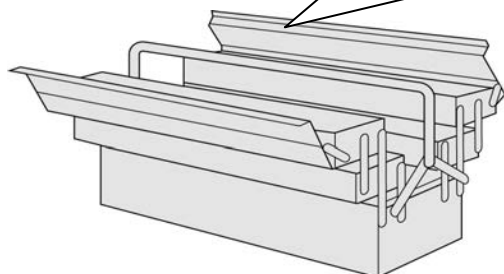
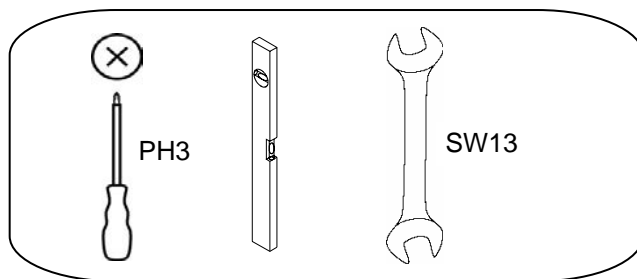
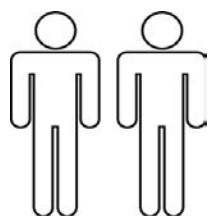
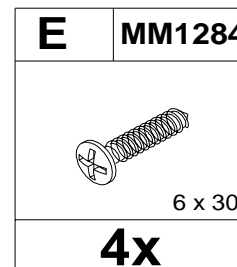
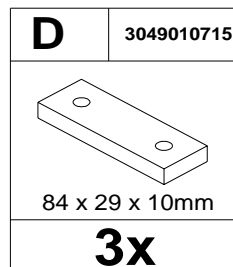
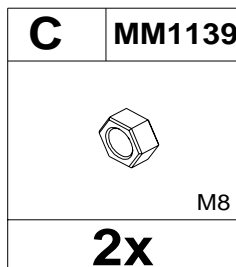
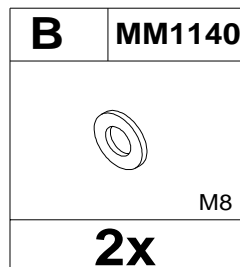
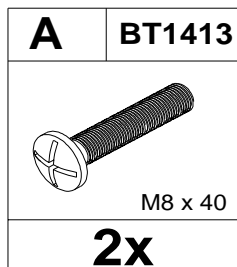

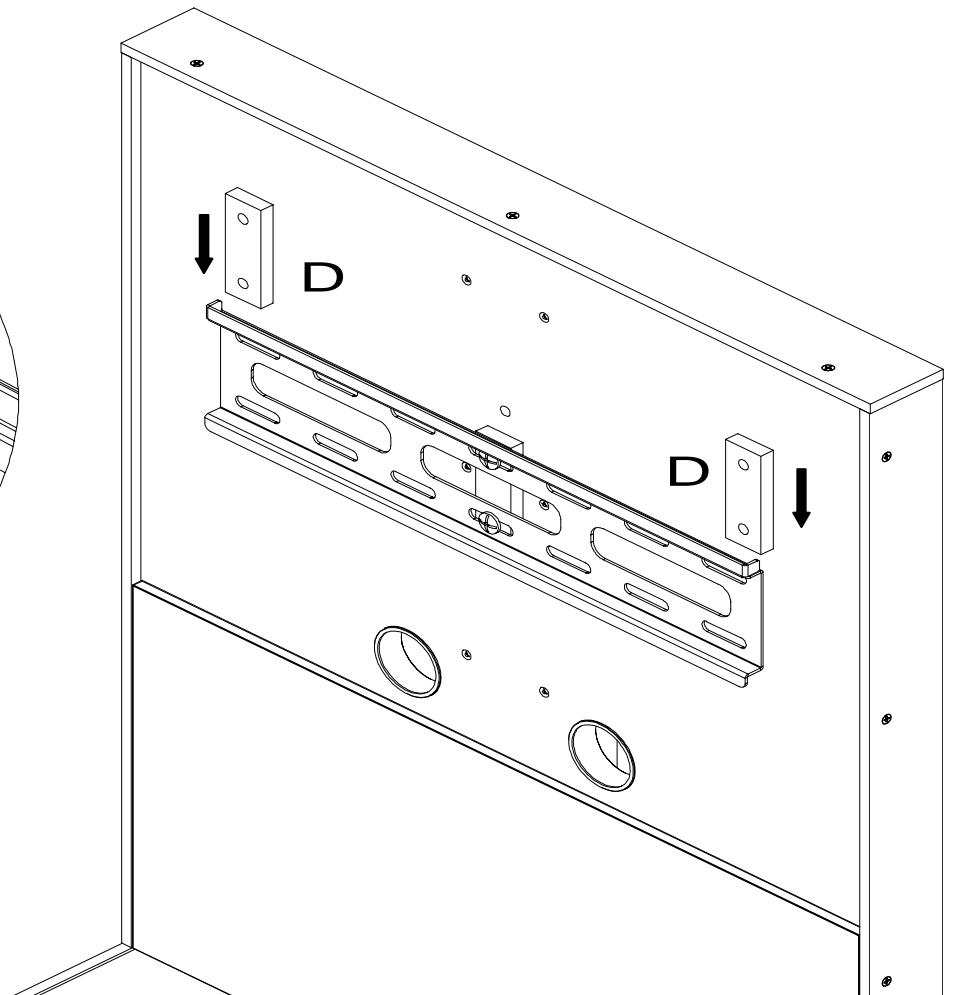
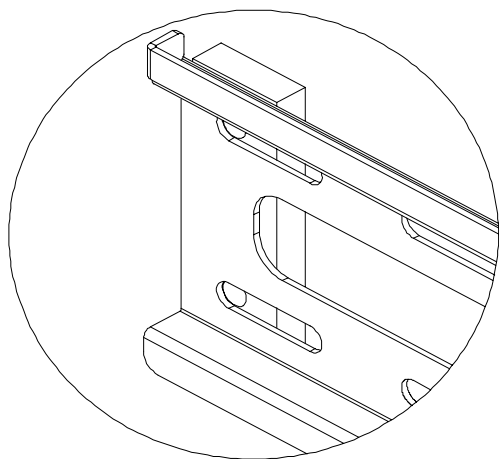
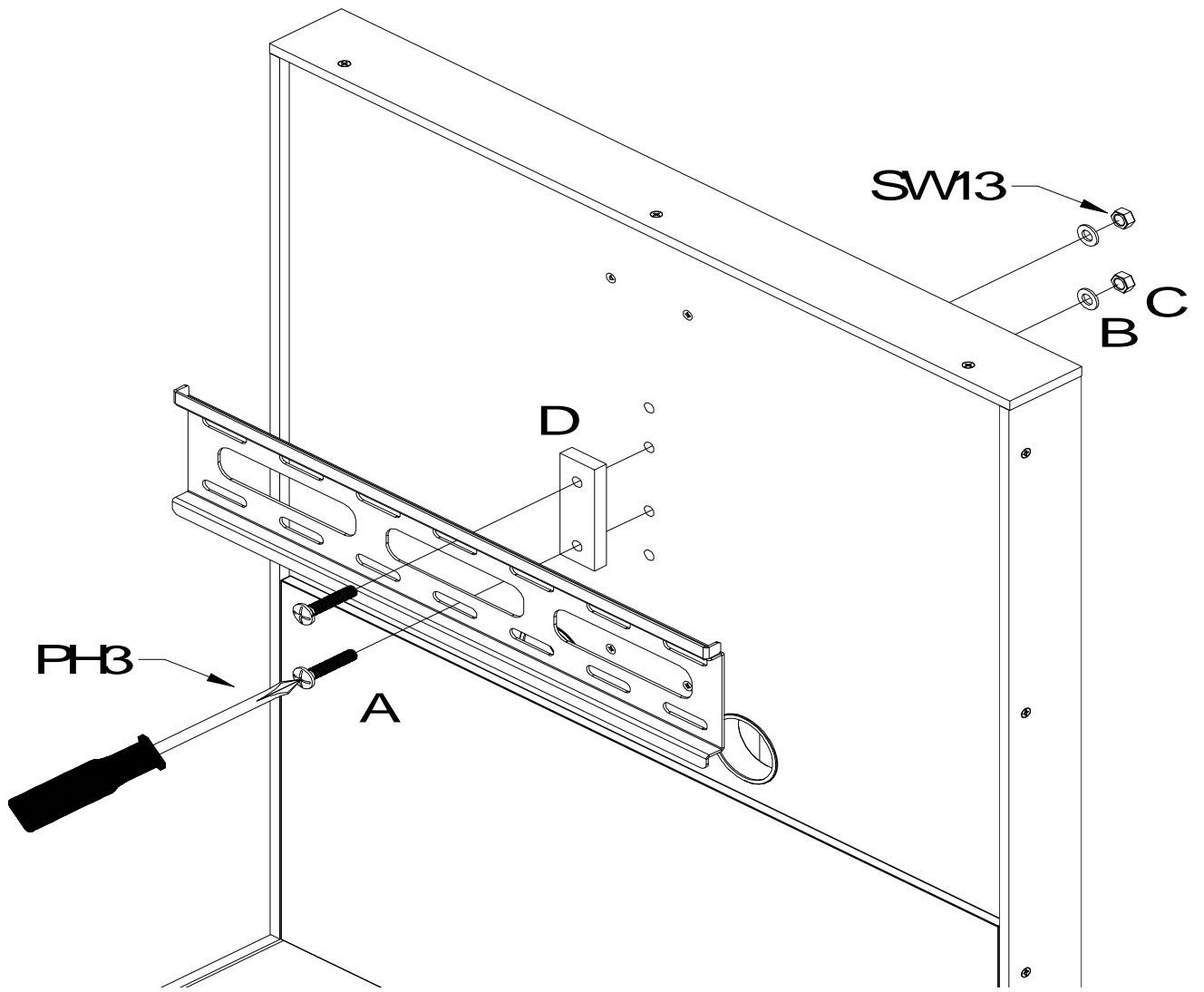



PH3

E

E

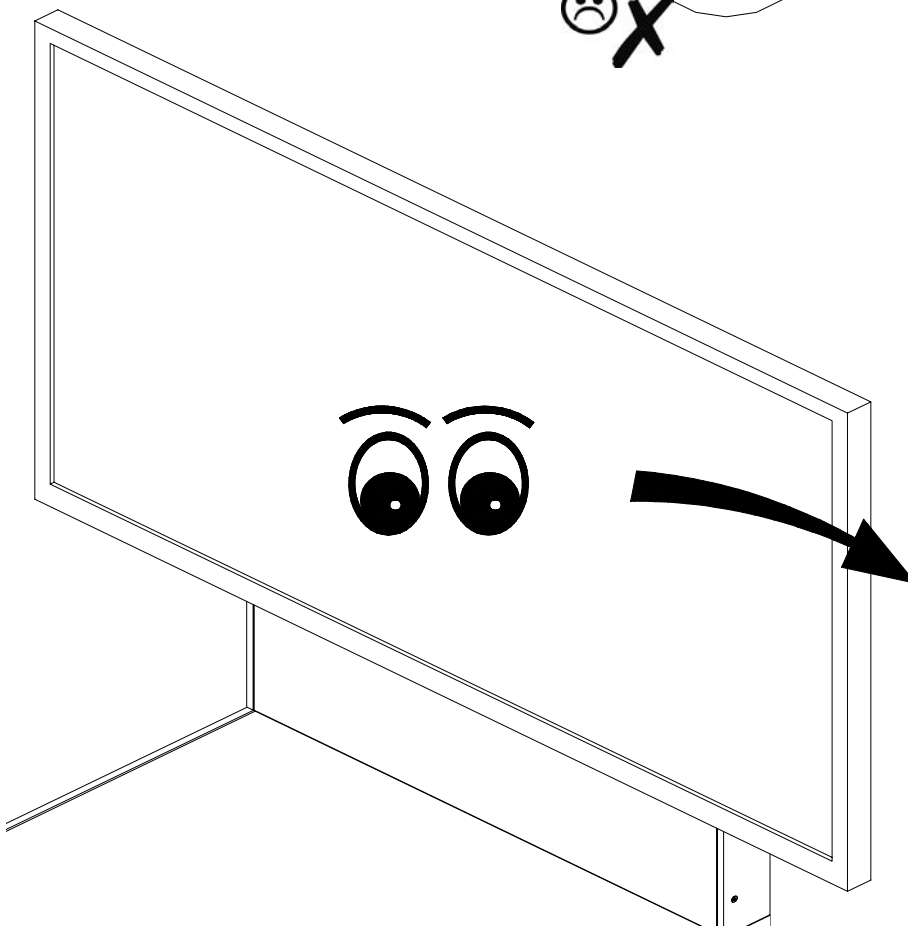
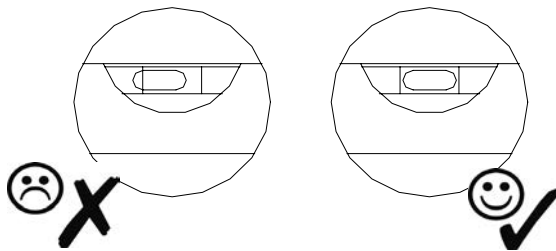

**TV Wandhalterung**  
**Wall Bracket**



00108770  
00108771

# Q-Media

## Soundbarhalterung



# Musterring



Nur für VESA 400 x 400  
Only for VESA 400 x 400

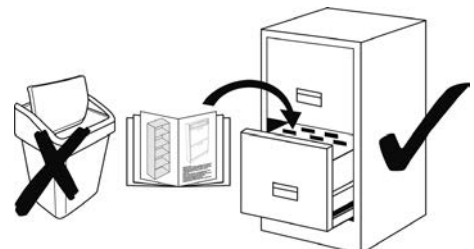
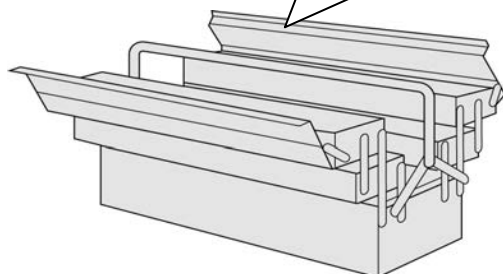
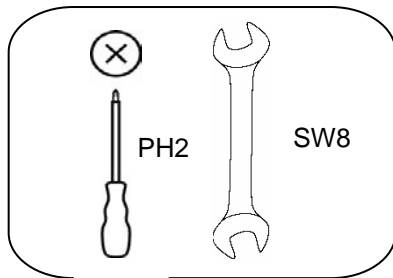
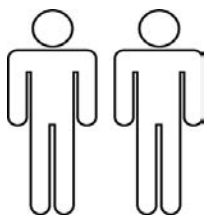
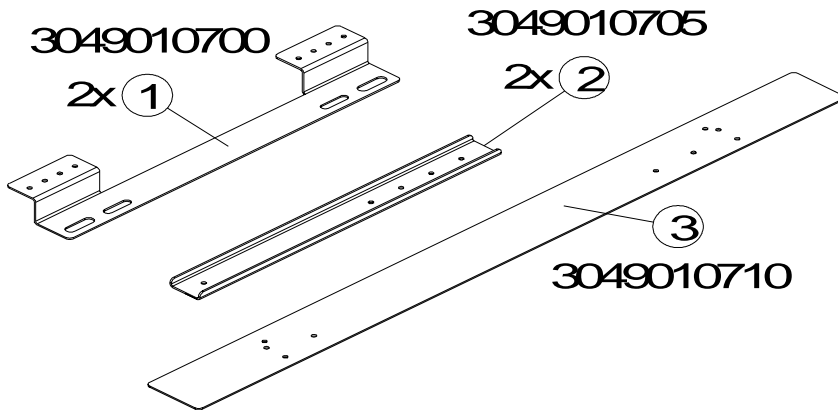
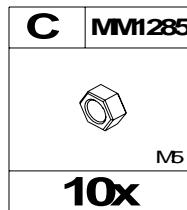
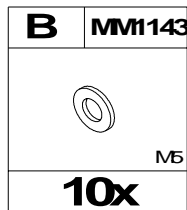
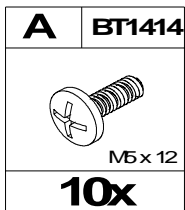
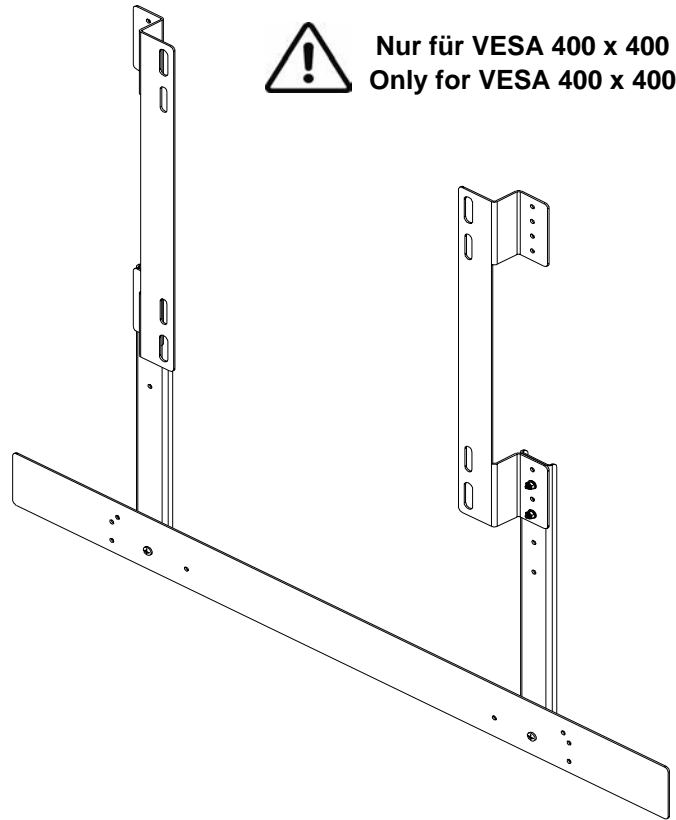

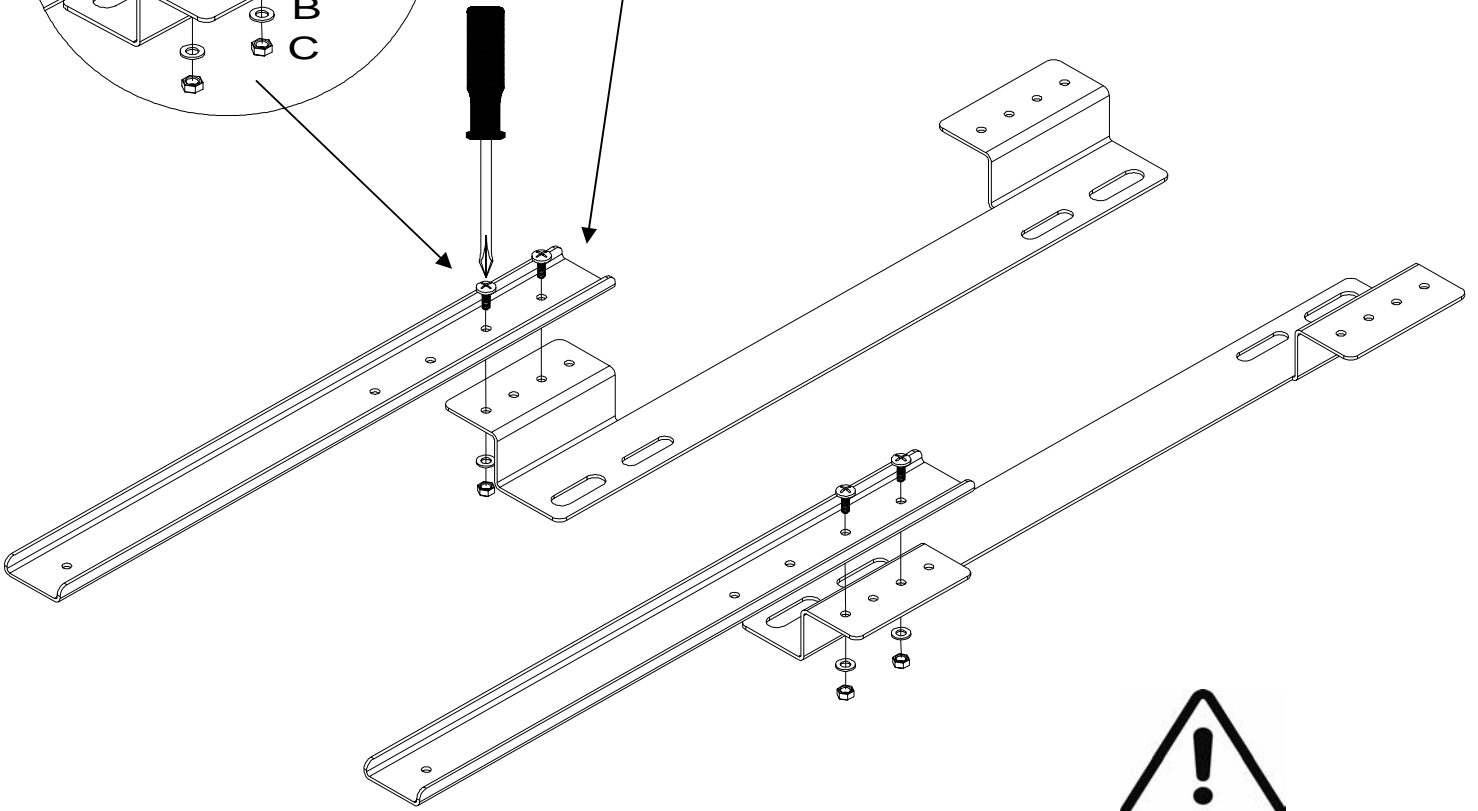
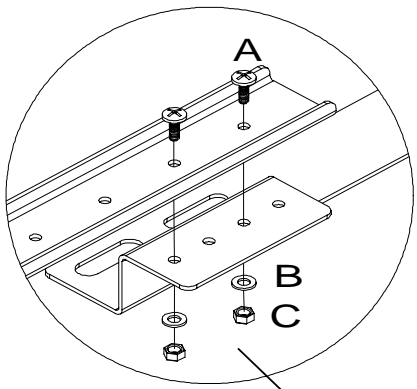
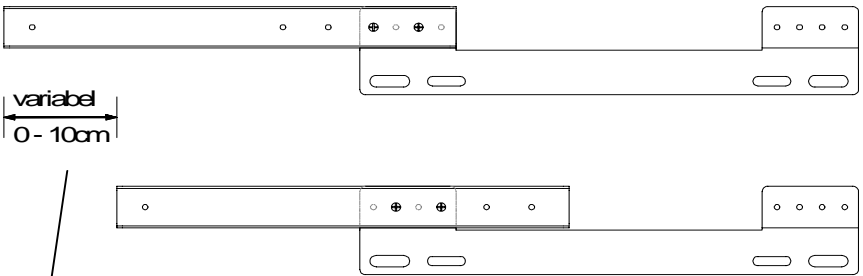

**Nur für VESA 400 x 400**  
**Only for VESA 400 x 400**

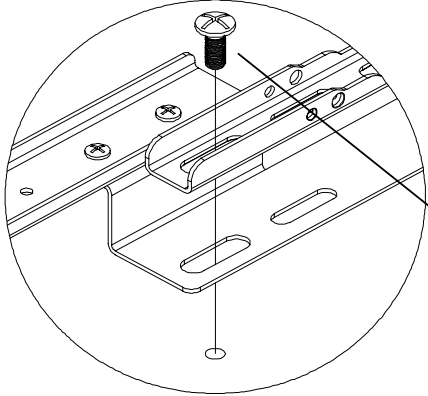
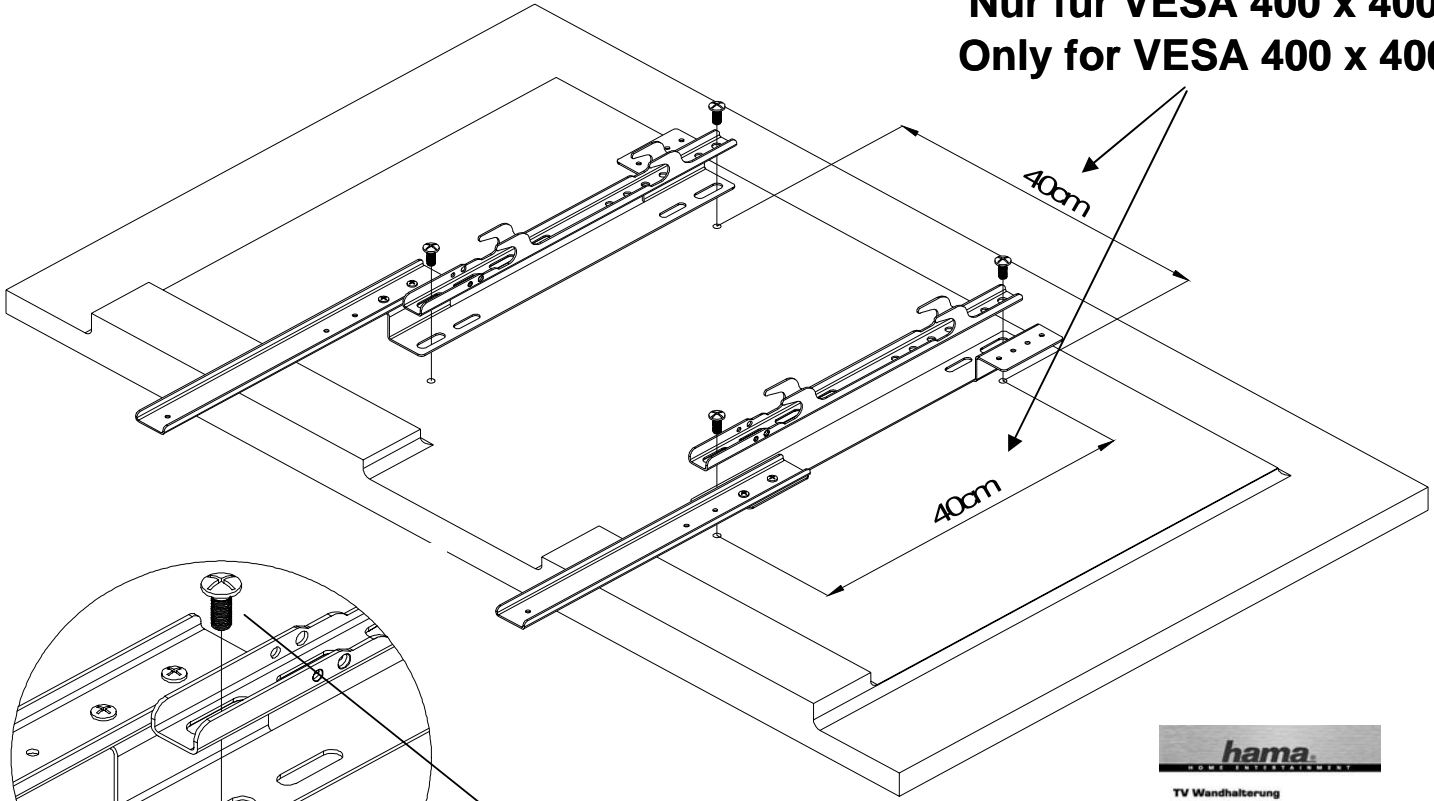

Schraube / Screw

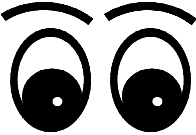

TV Wandhalterung  
TV Wall Bracket



00108730  
00108744

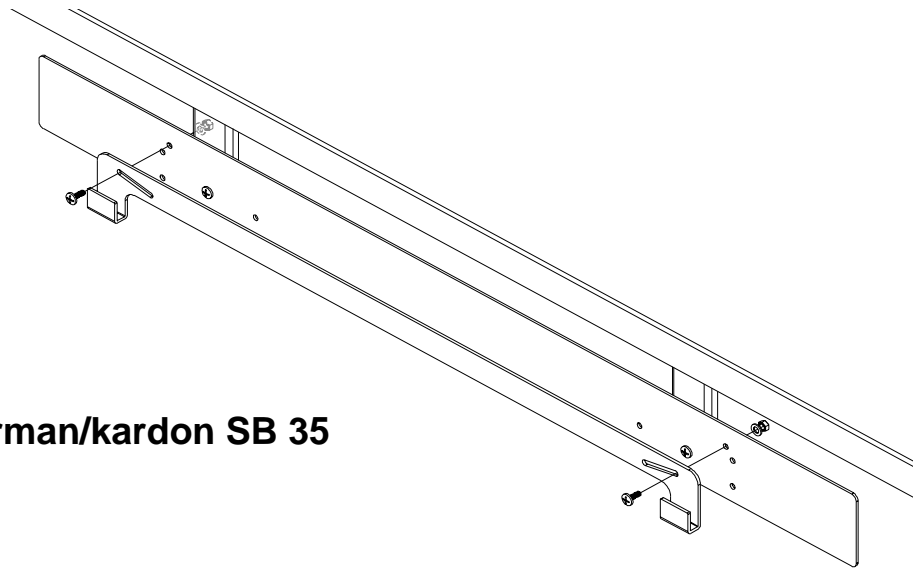
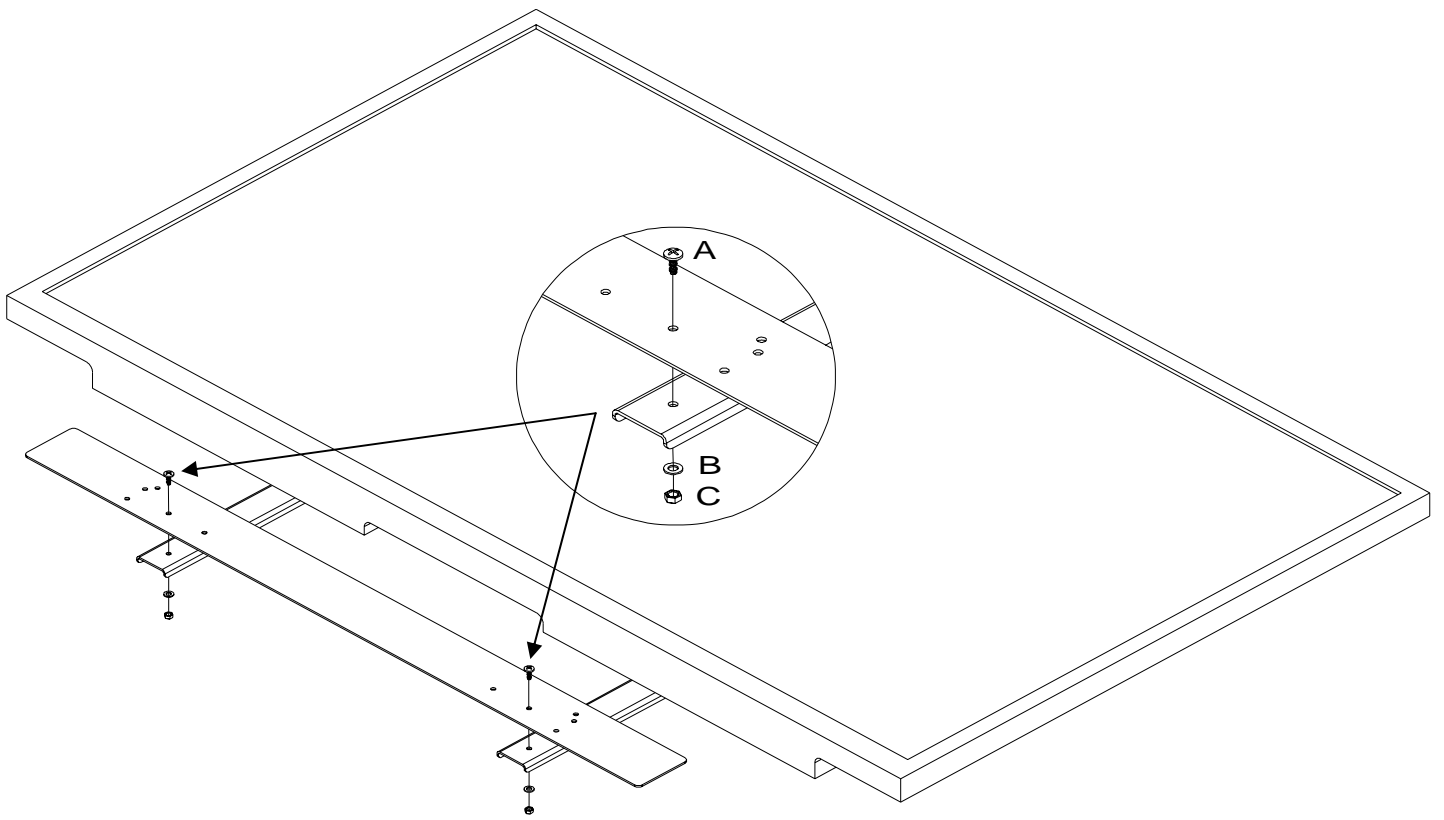

**Beispiel / example: harman/kardon SB 35**

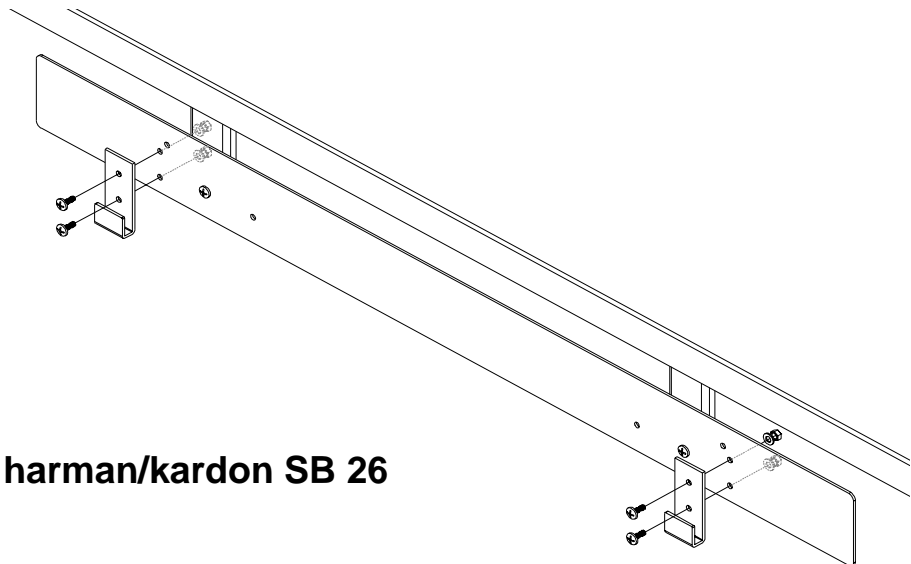

**Beispiel / example: harman/kardon SB 26**

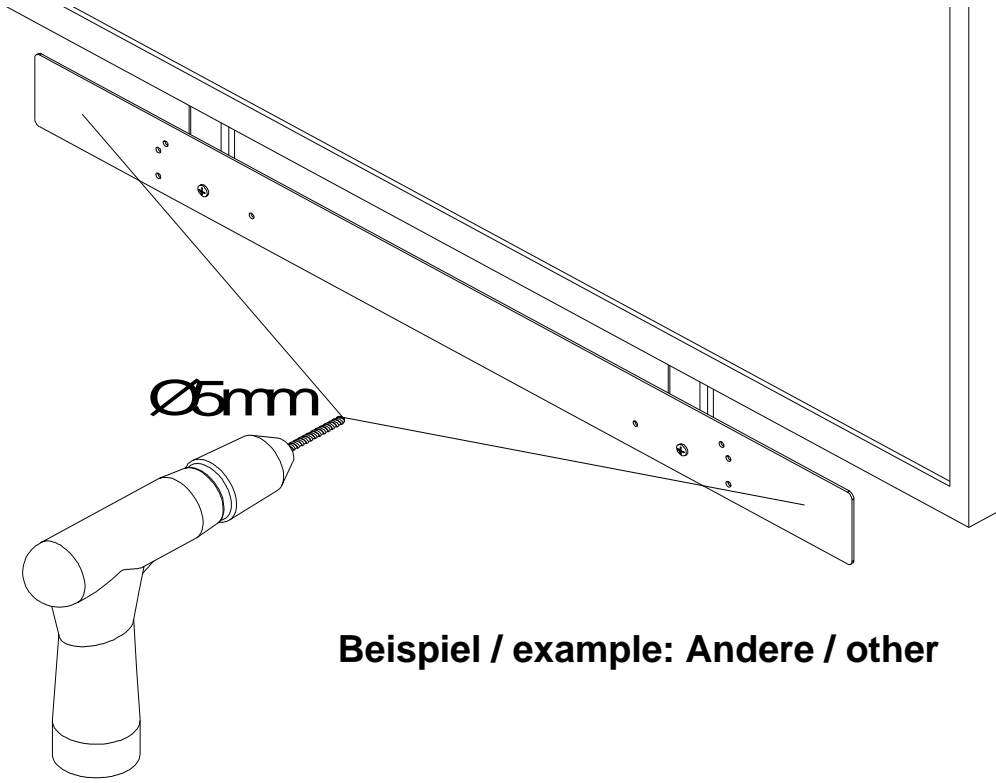

Beispiel / example: Andere / other

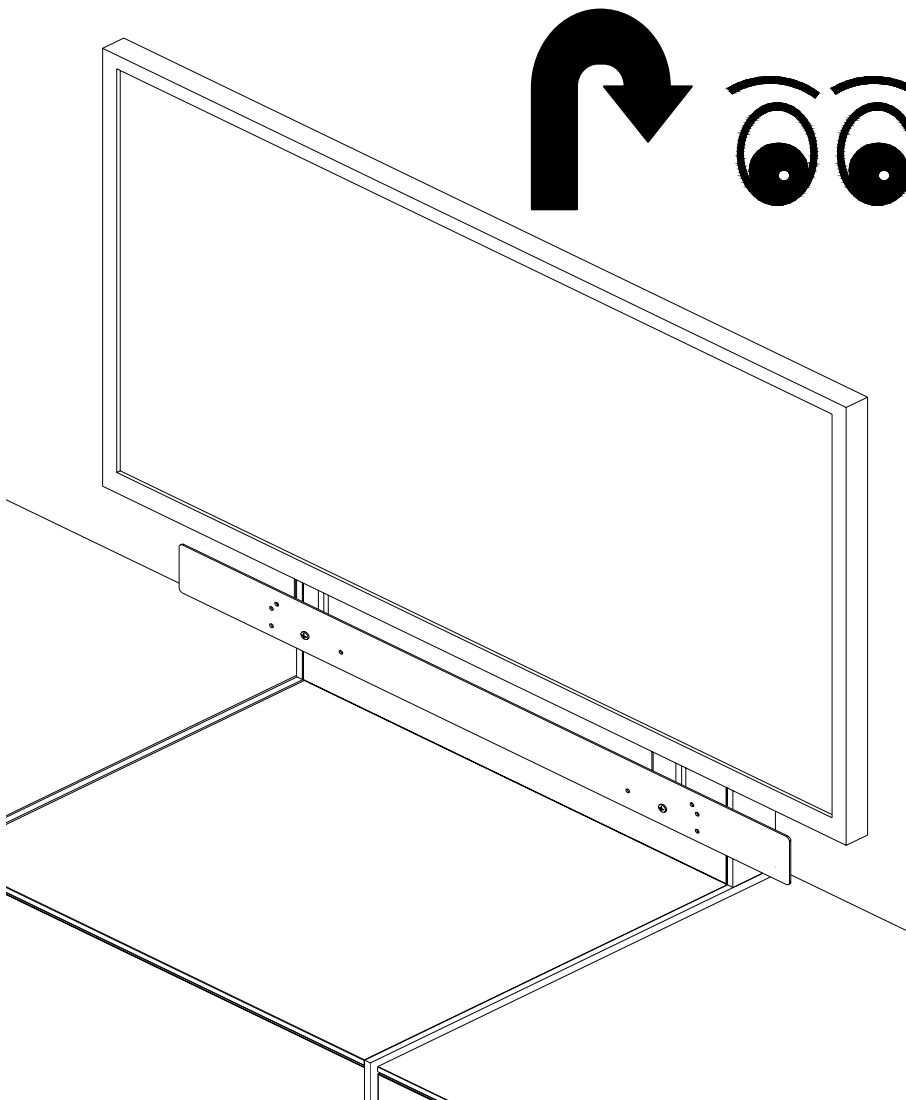

TV Wandhalterung  
TV Wall Bracket



00108730  
00108744



# Fußgestell Typ 670

# Q-Media



# Musterring

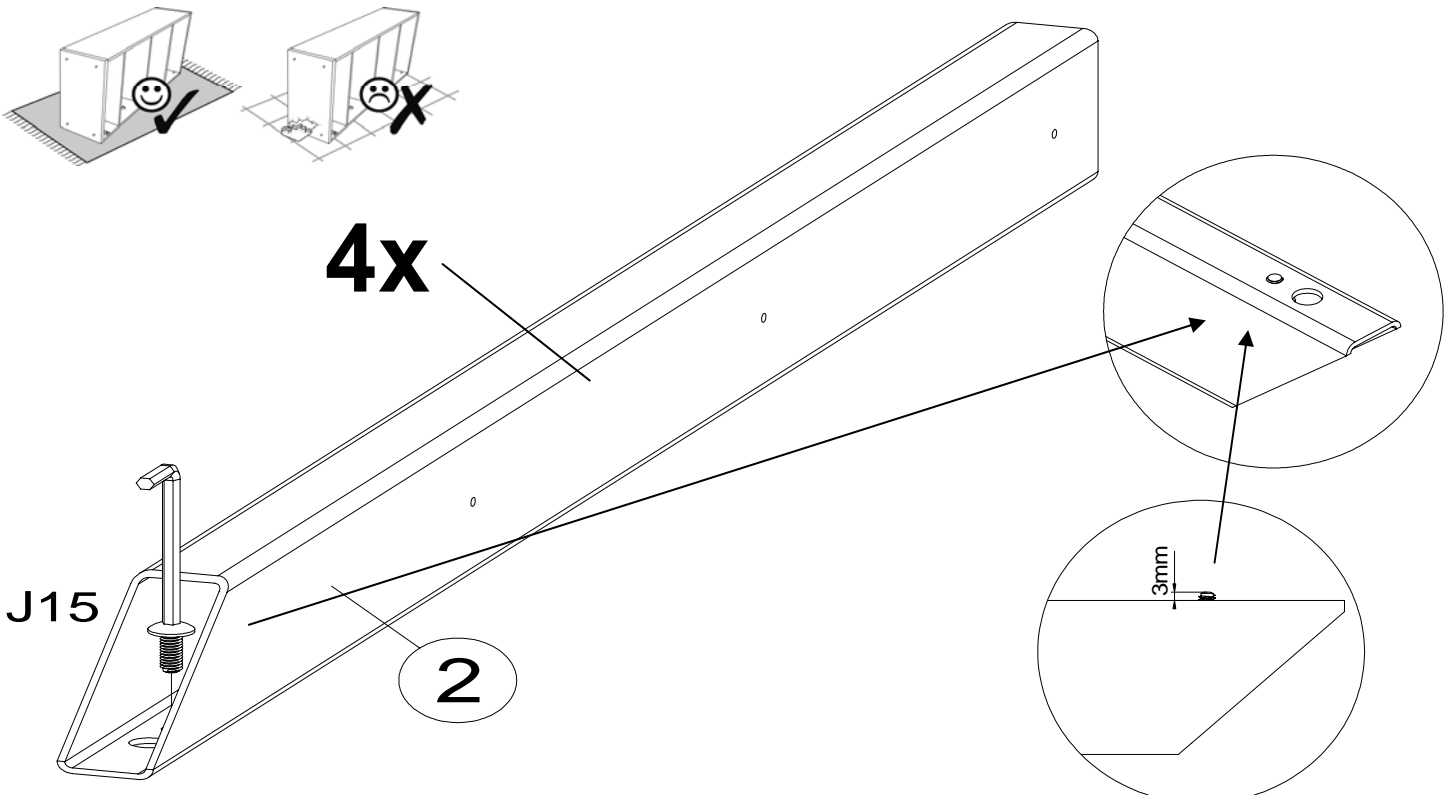
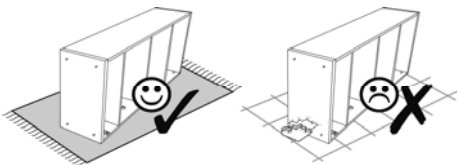
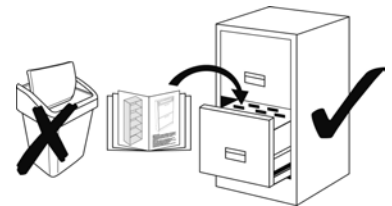
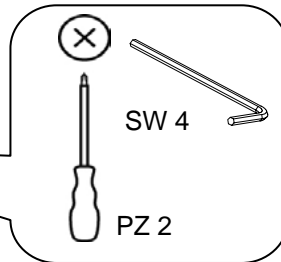
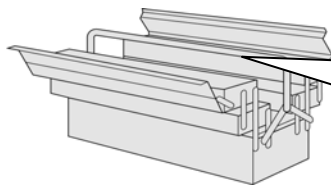
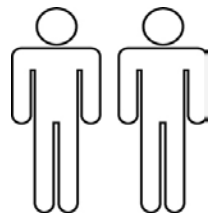
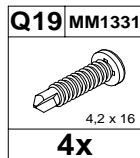
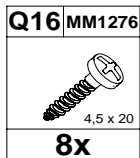
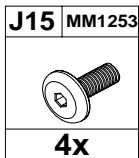
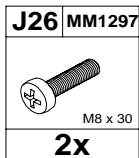
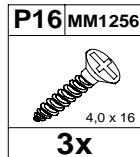
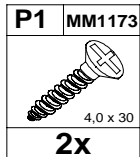
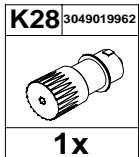
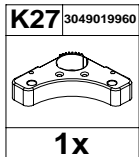
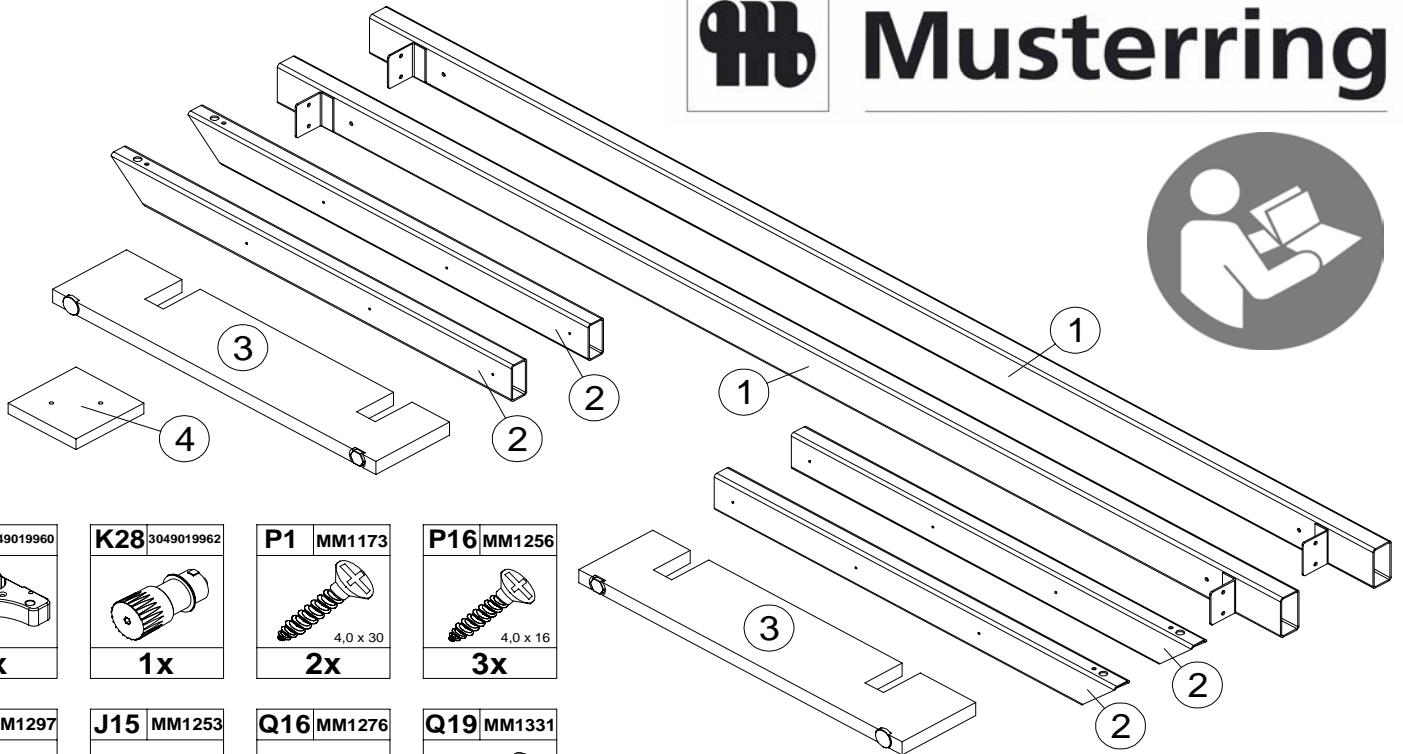

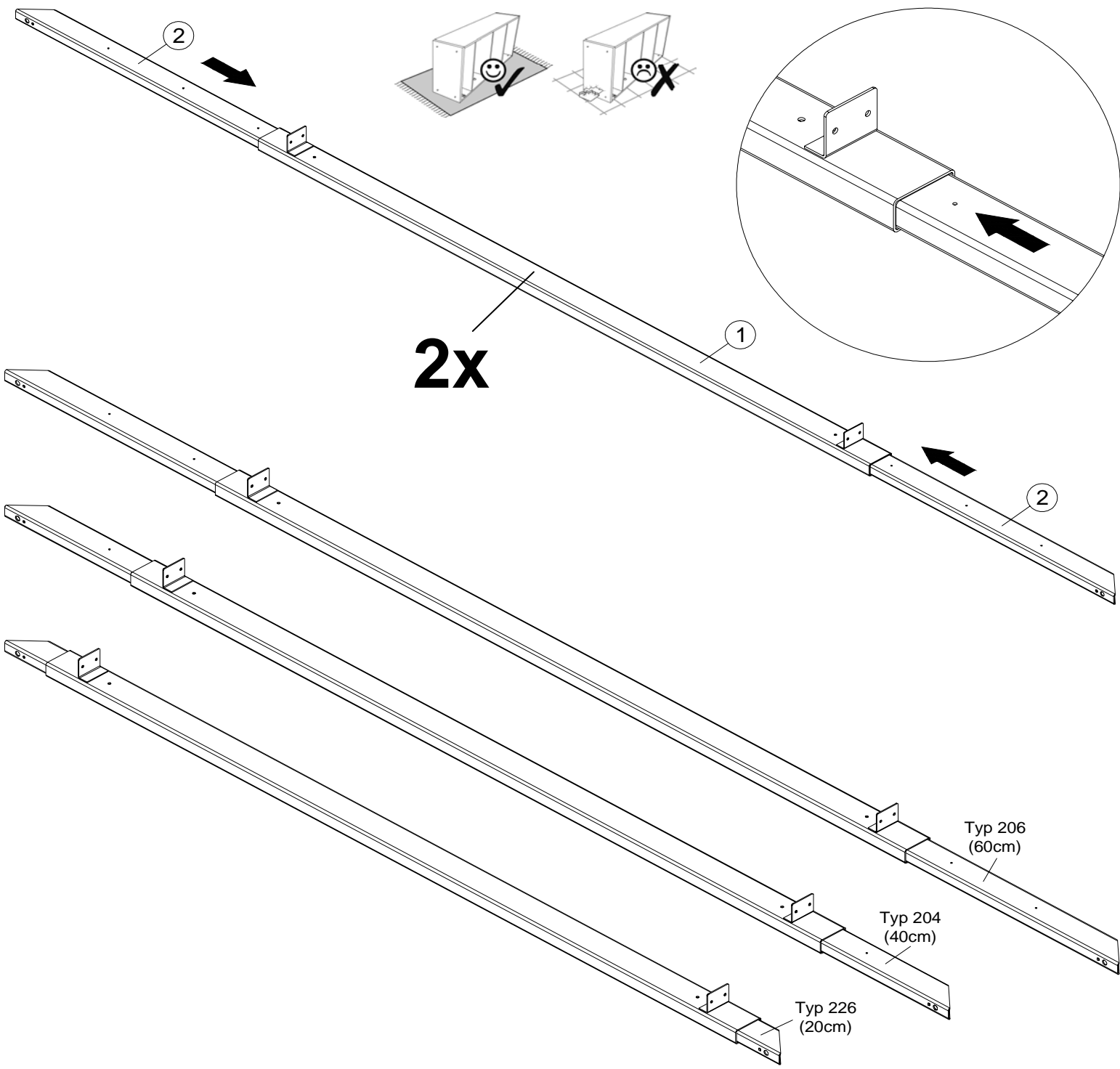

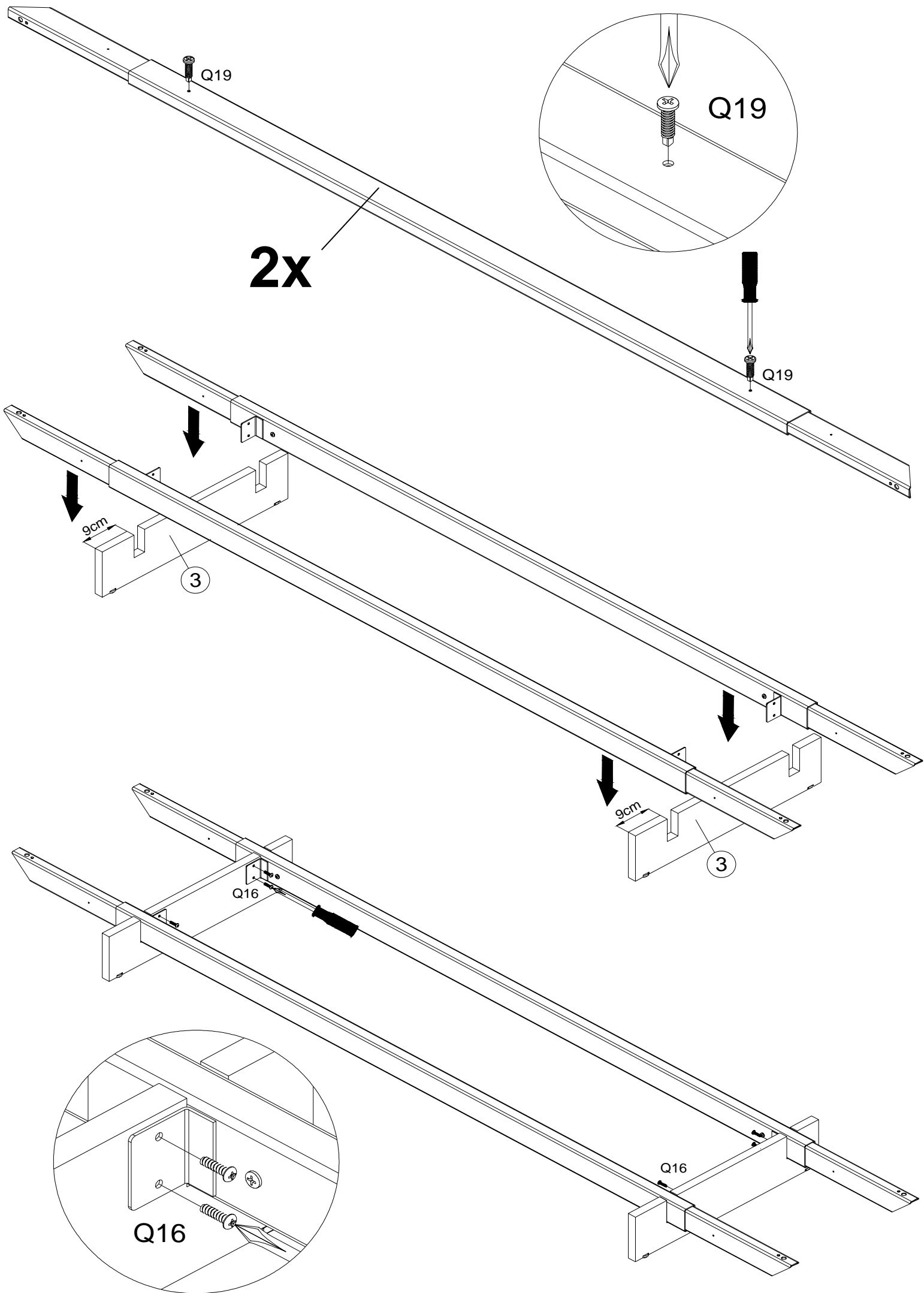

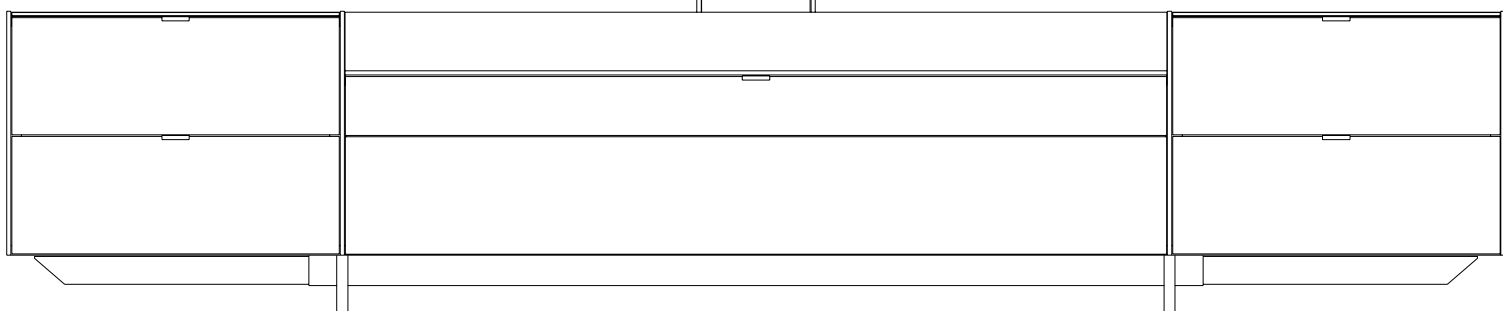
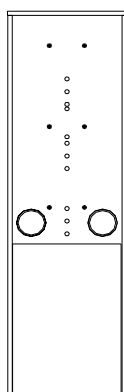
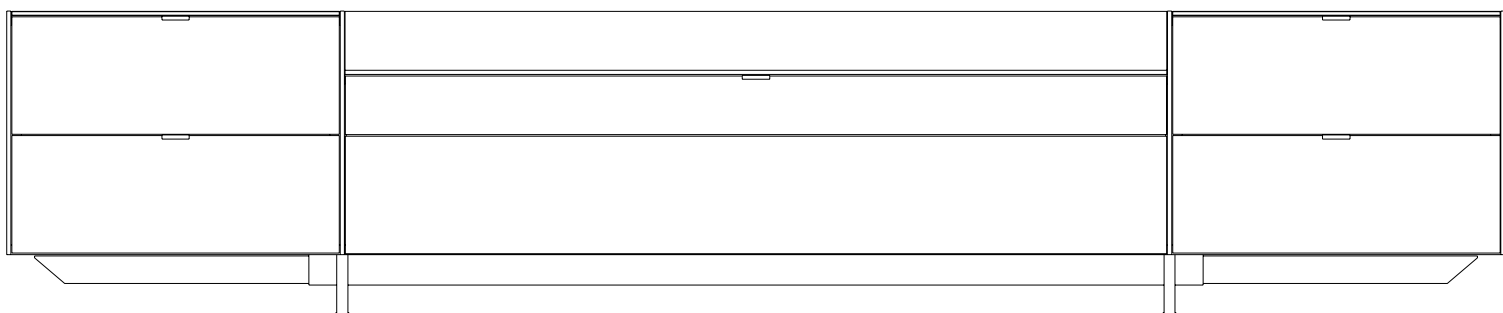
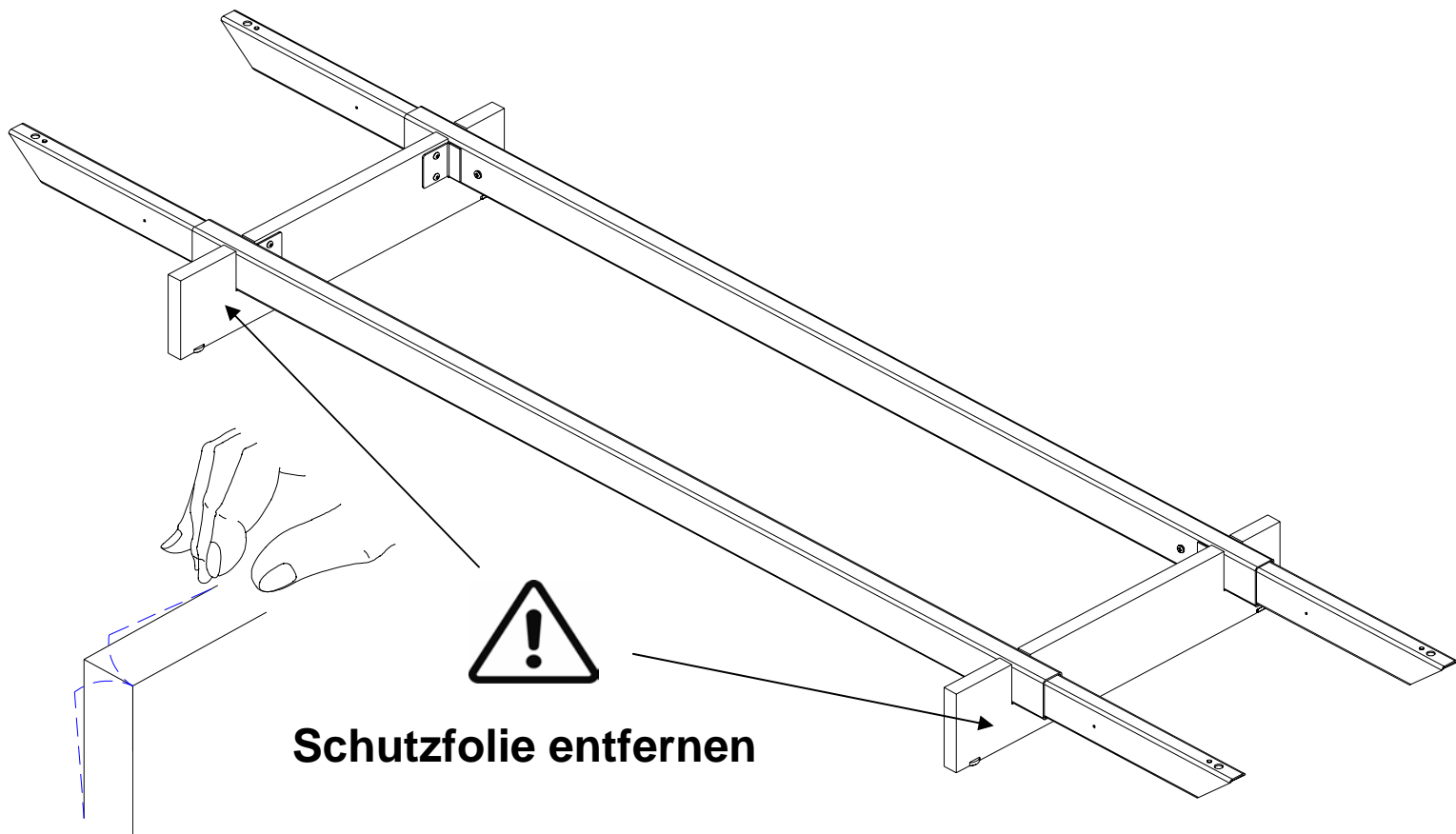

# Q-Media

## Vorschlagskombinationen 724 / 725 / 727

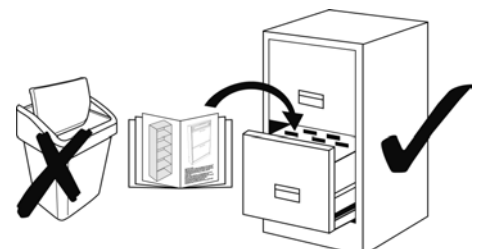
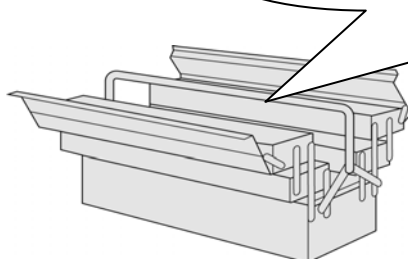
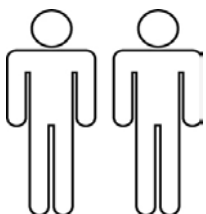
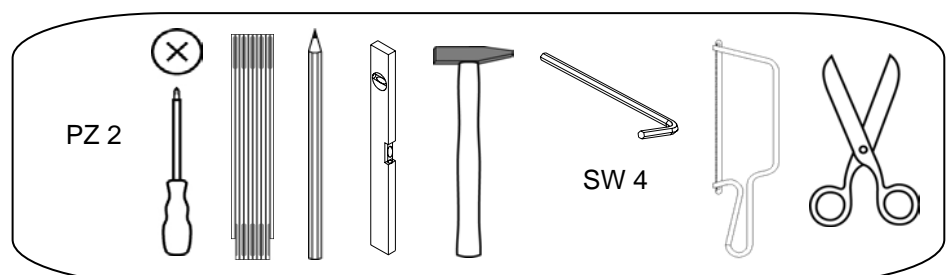
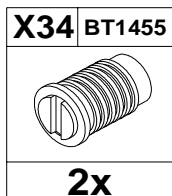
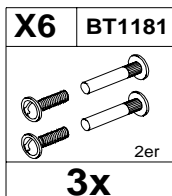
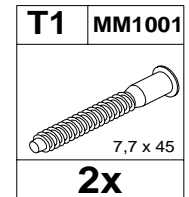
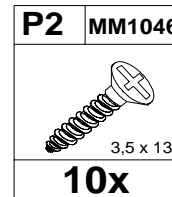
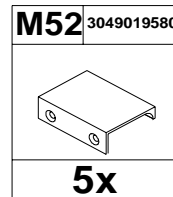
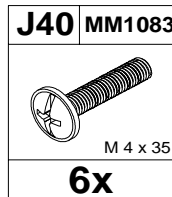
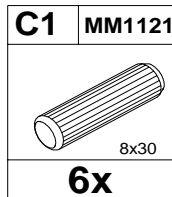
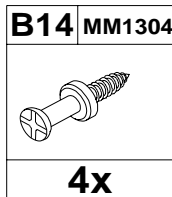
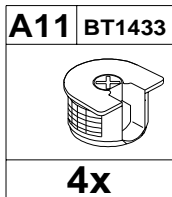
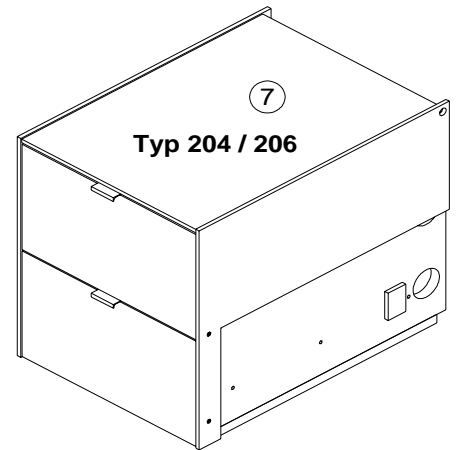
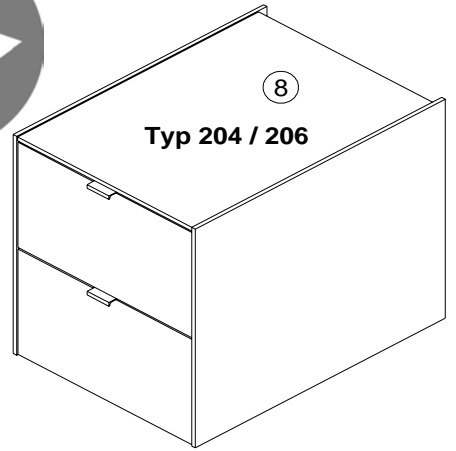
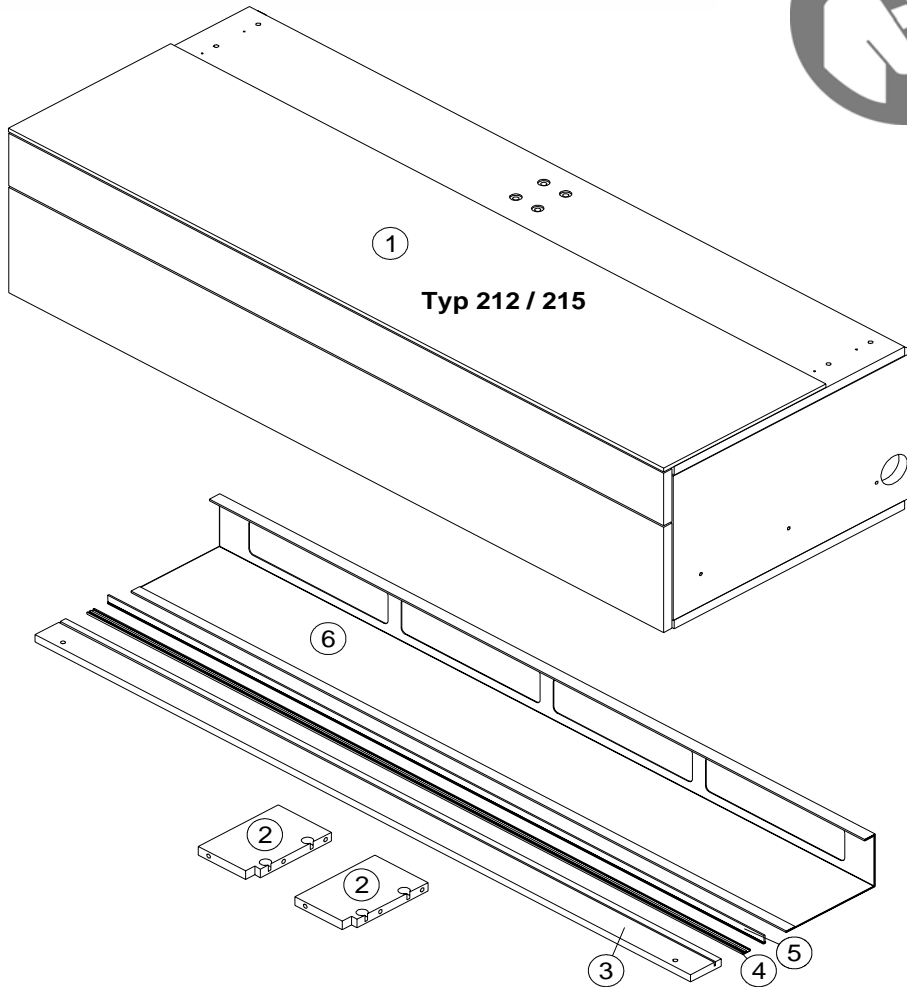

Ohne optionales TV-Panel:

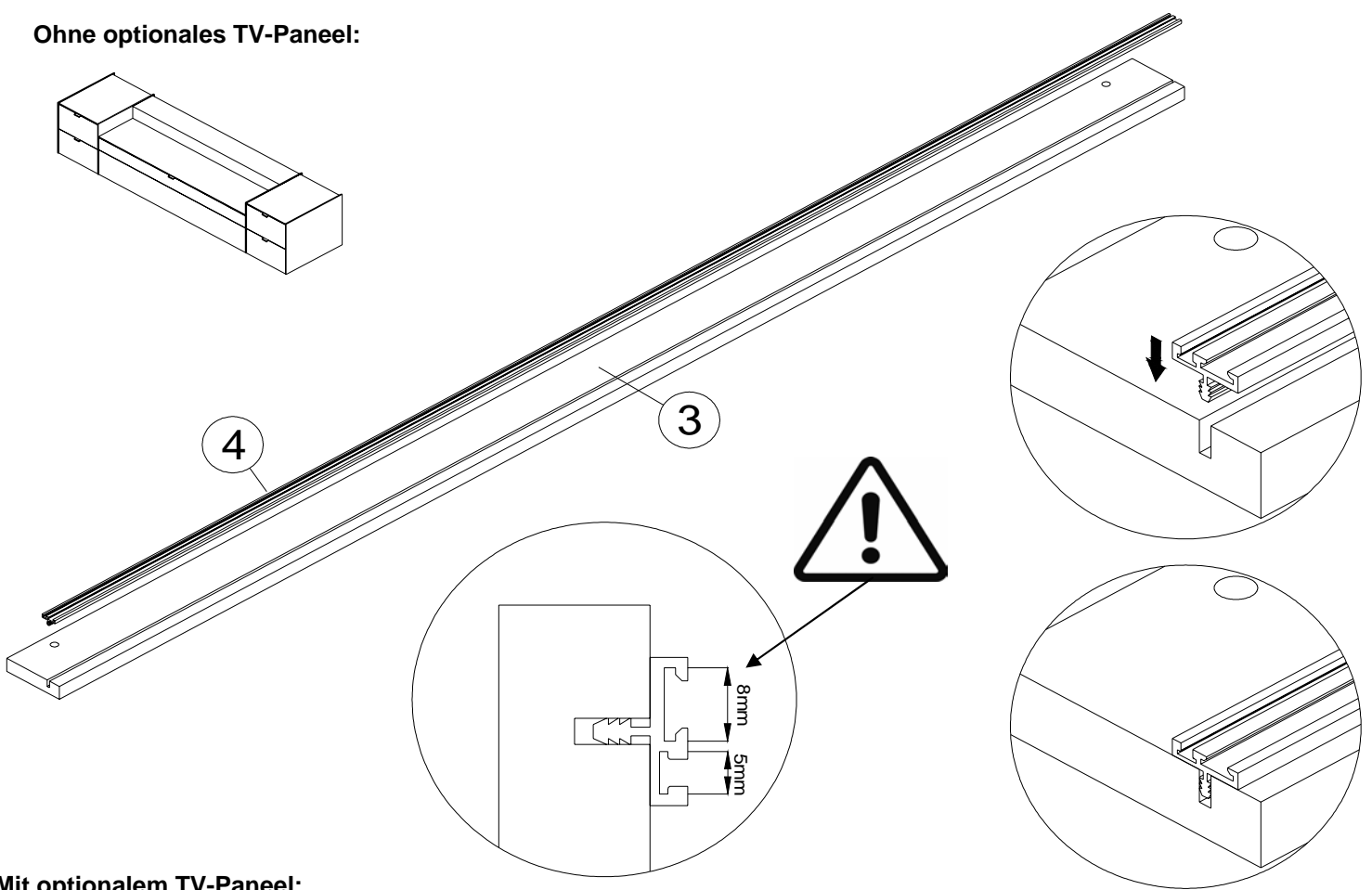

Mit optionalem TV-Panel:

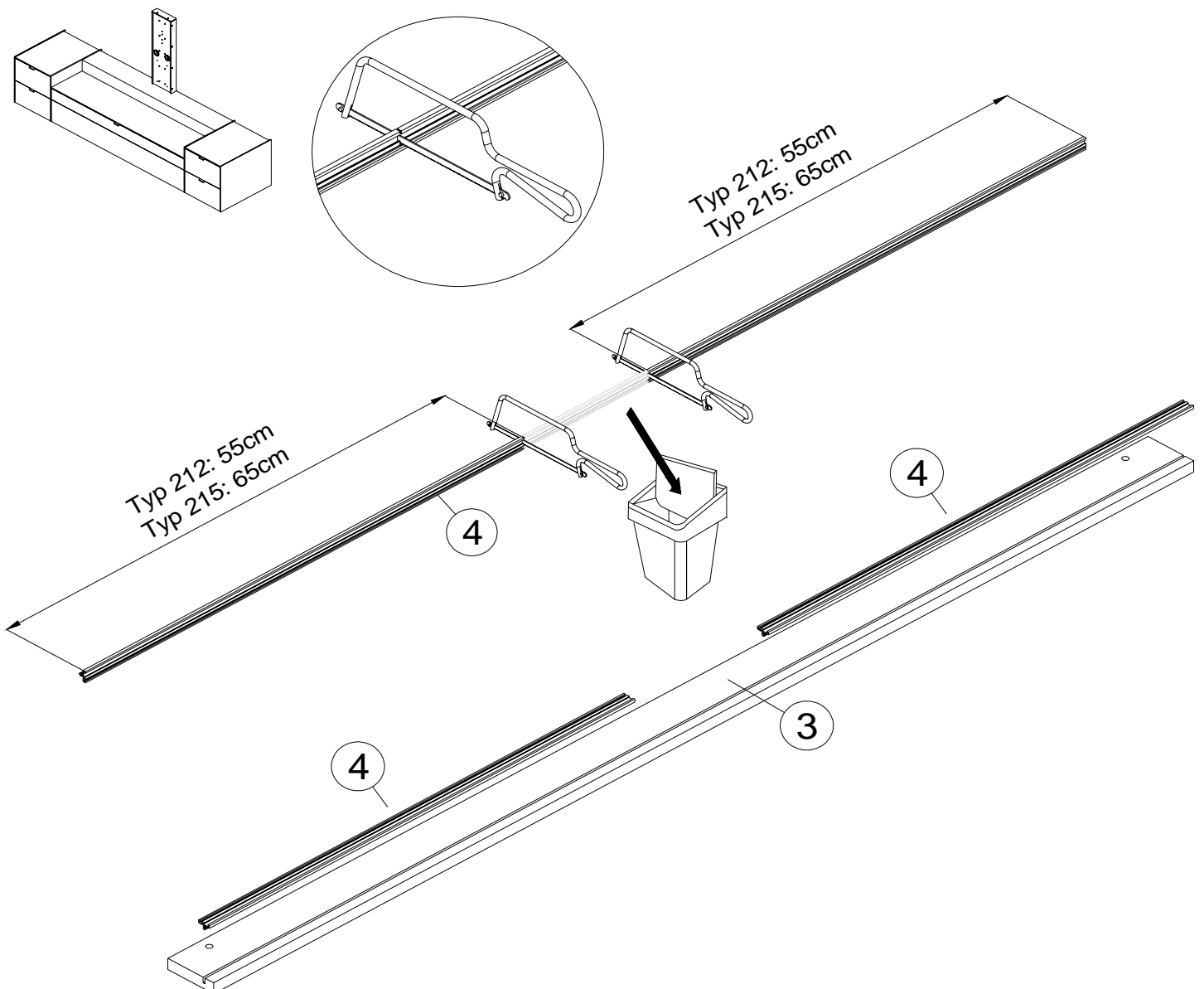

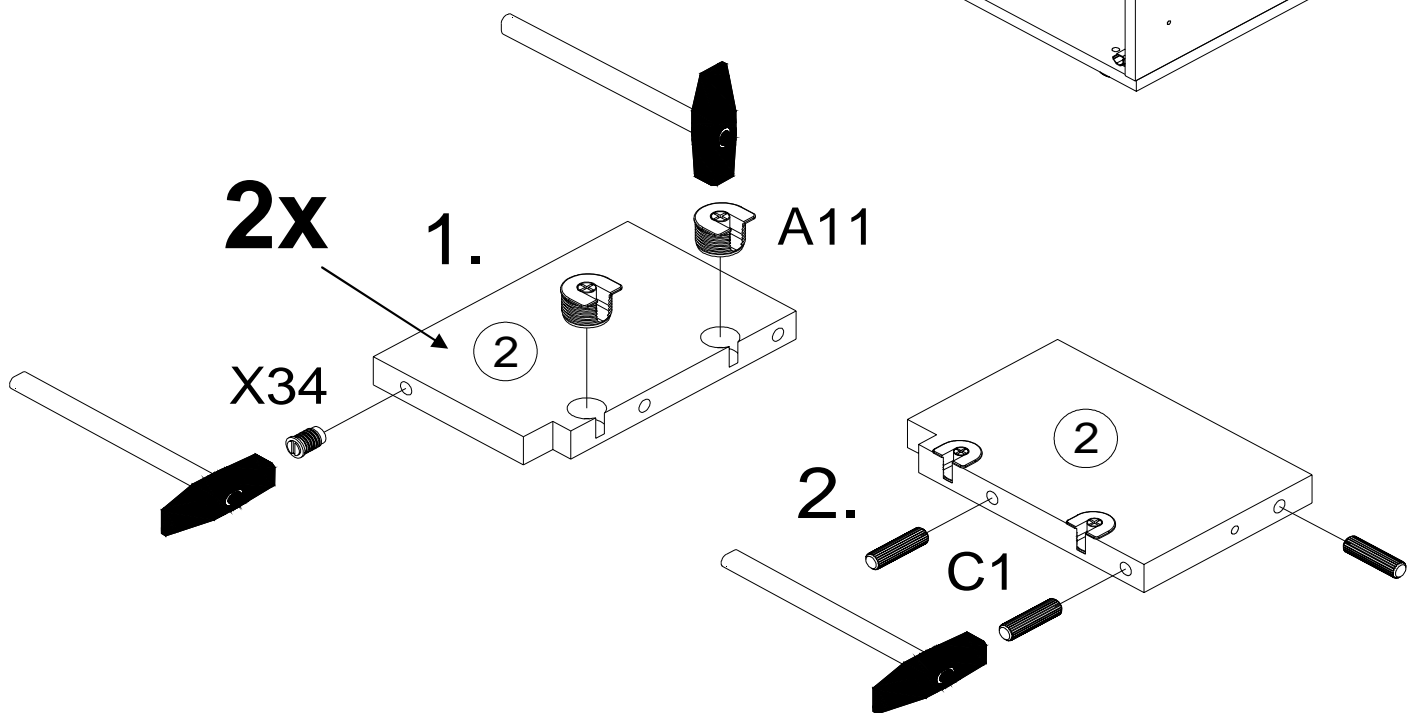
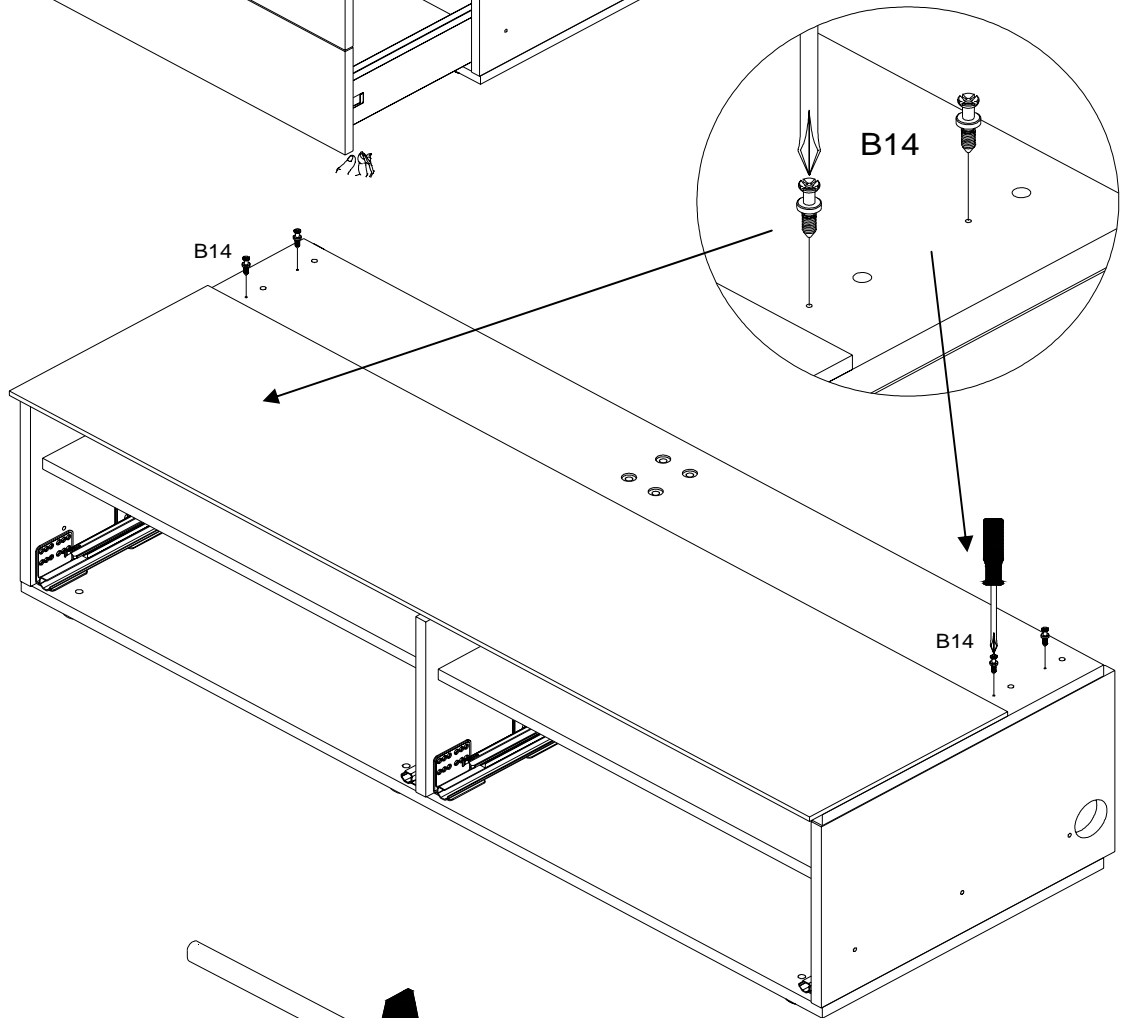
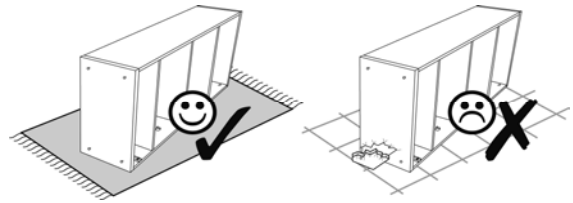
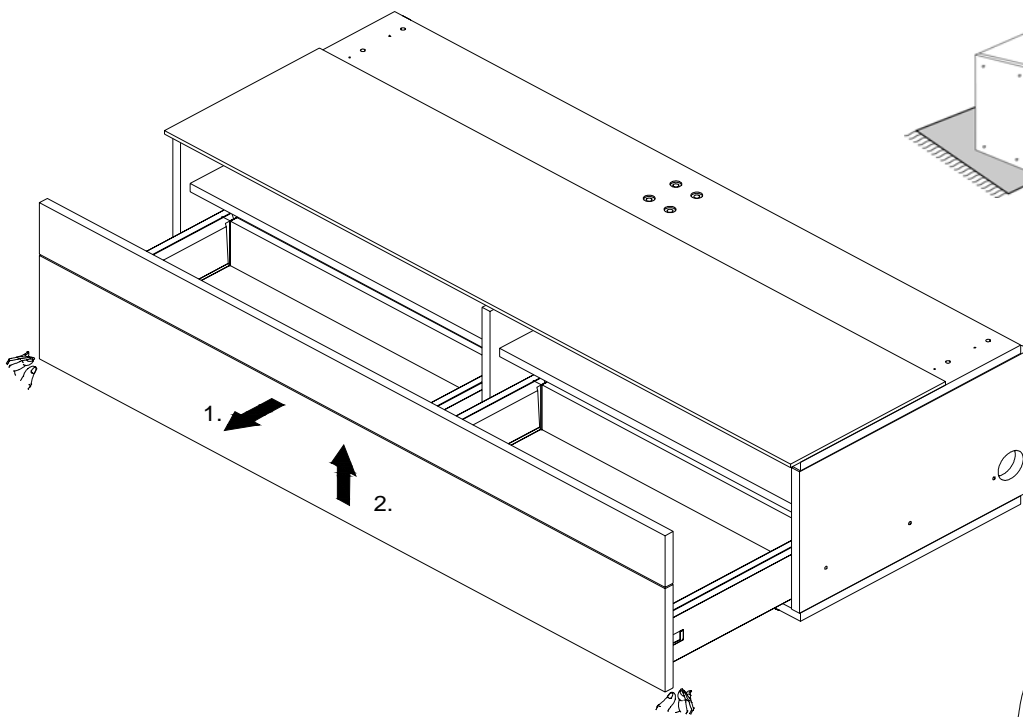

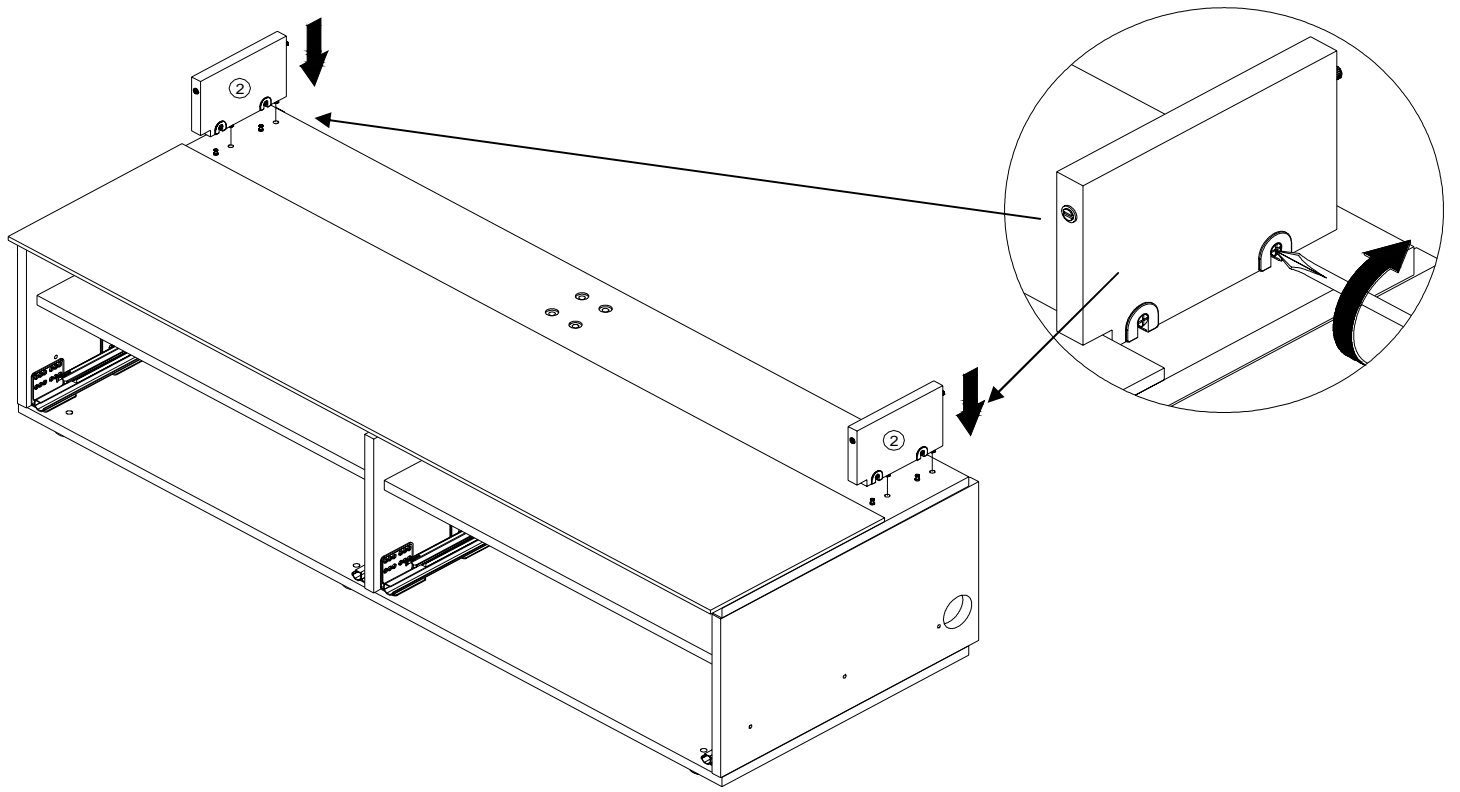

**Ohne optionales TV-Panel:**

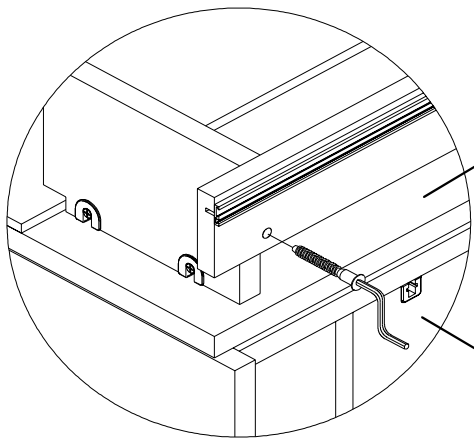
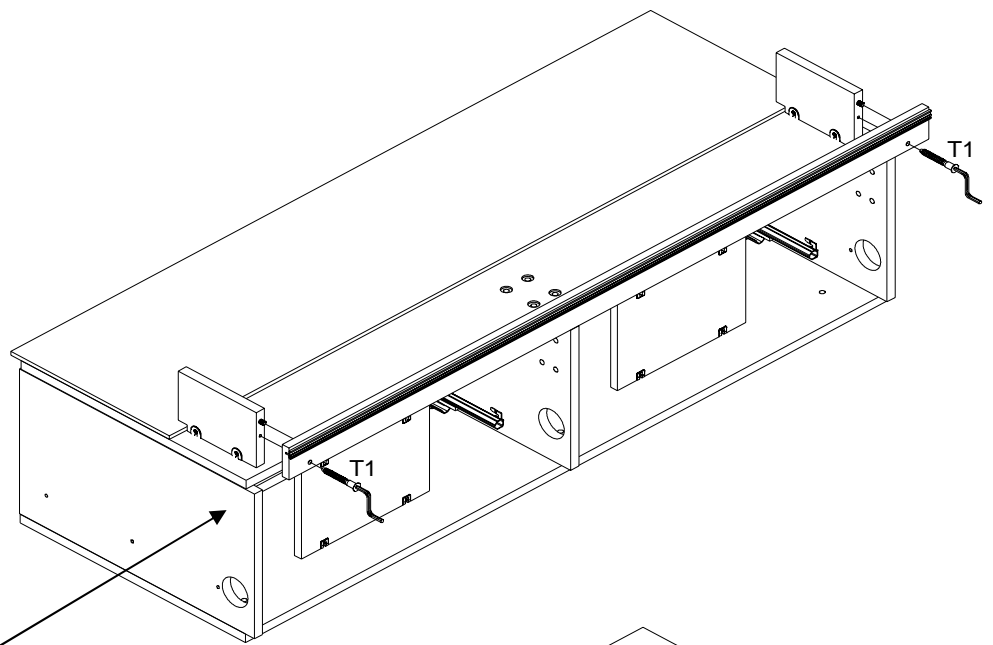
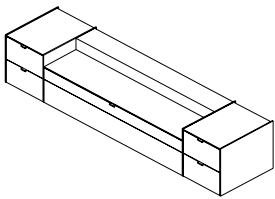

**Mit optionalem TV-Panel:**

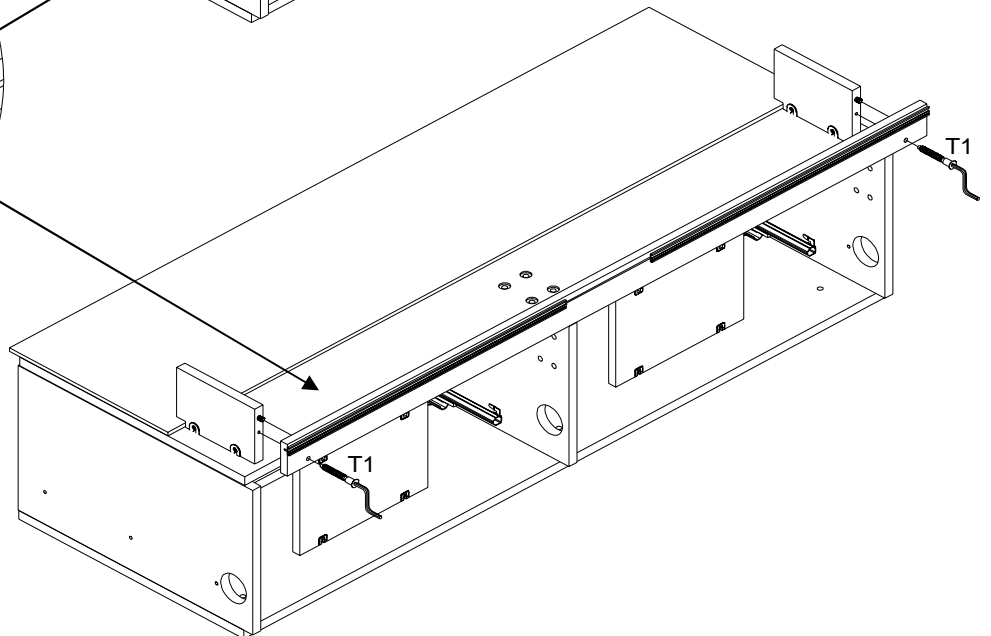
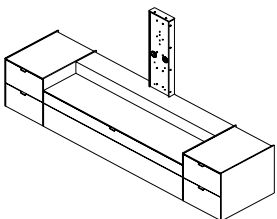



**Ohne optionales TV-Panel:**

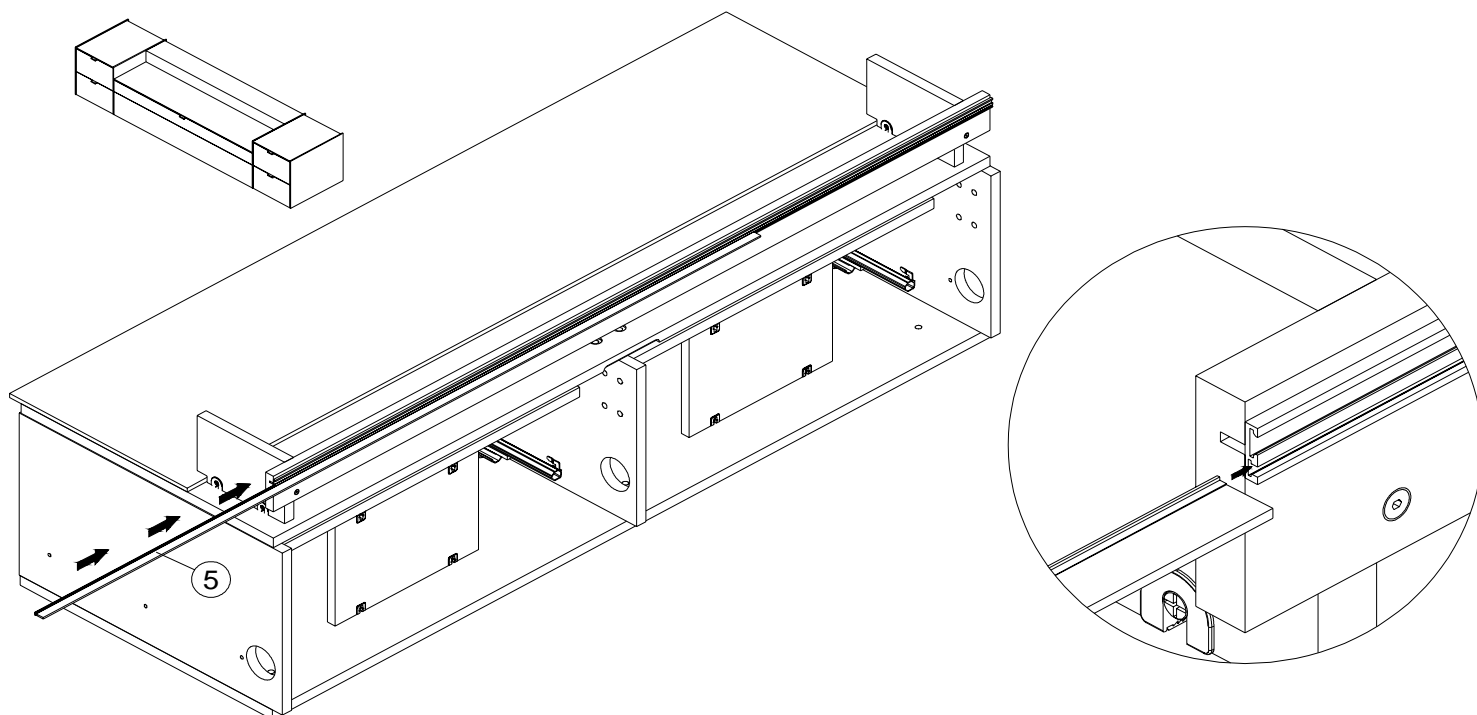

**Mit optionalem TV-Panel:**

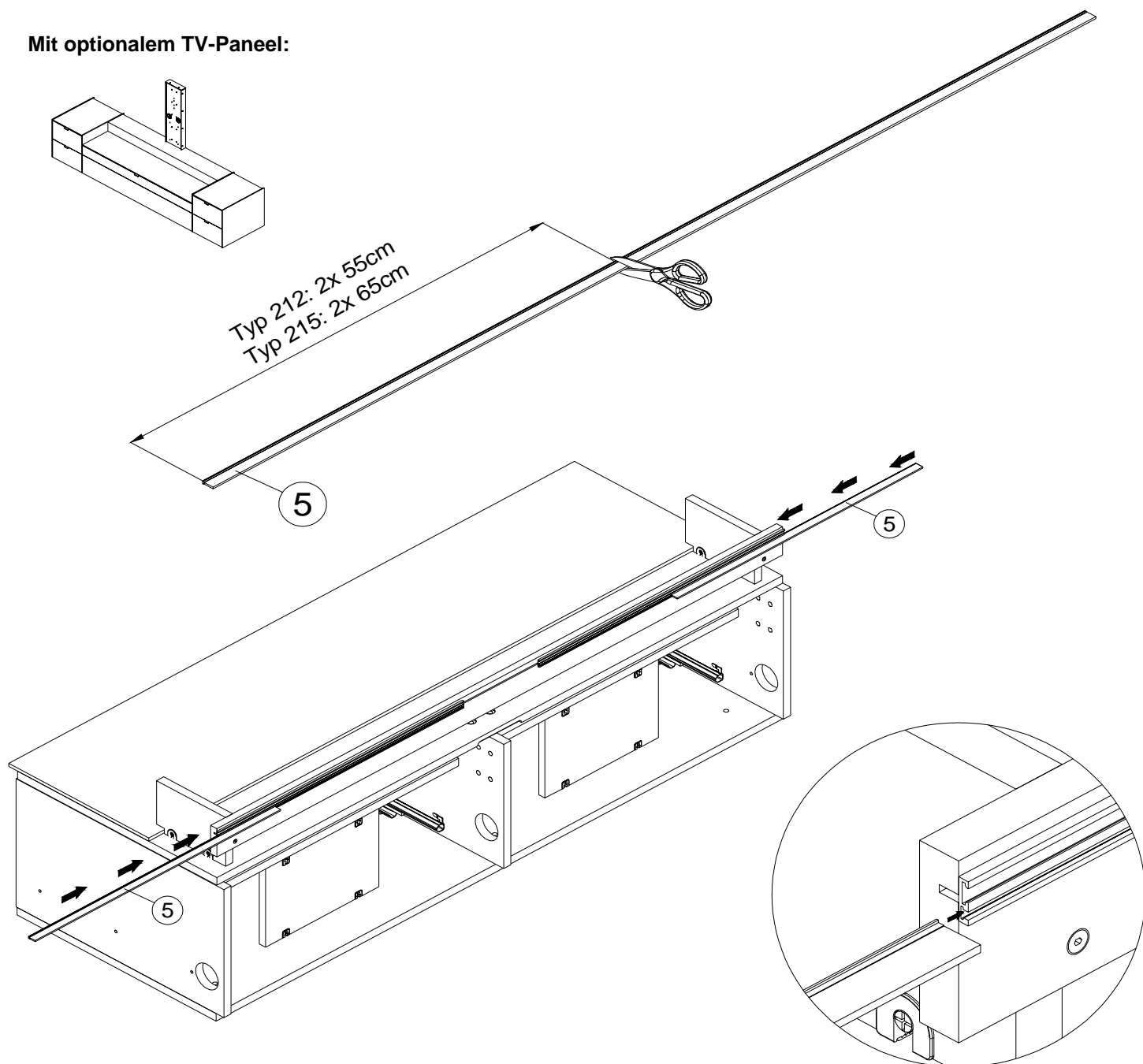

# Beleuchtung optional !

Ohne optionales TV-Panel:

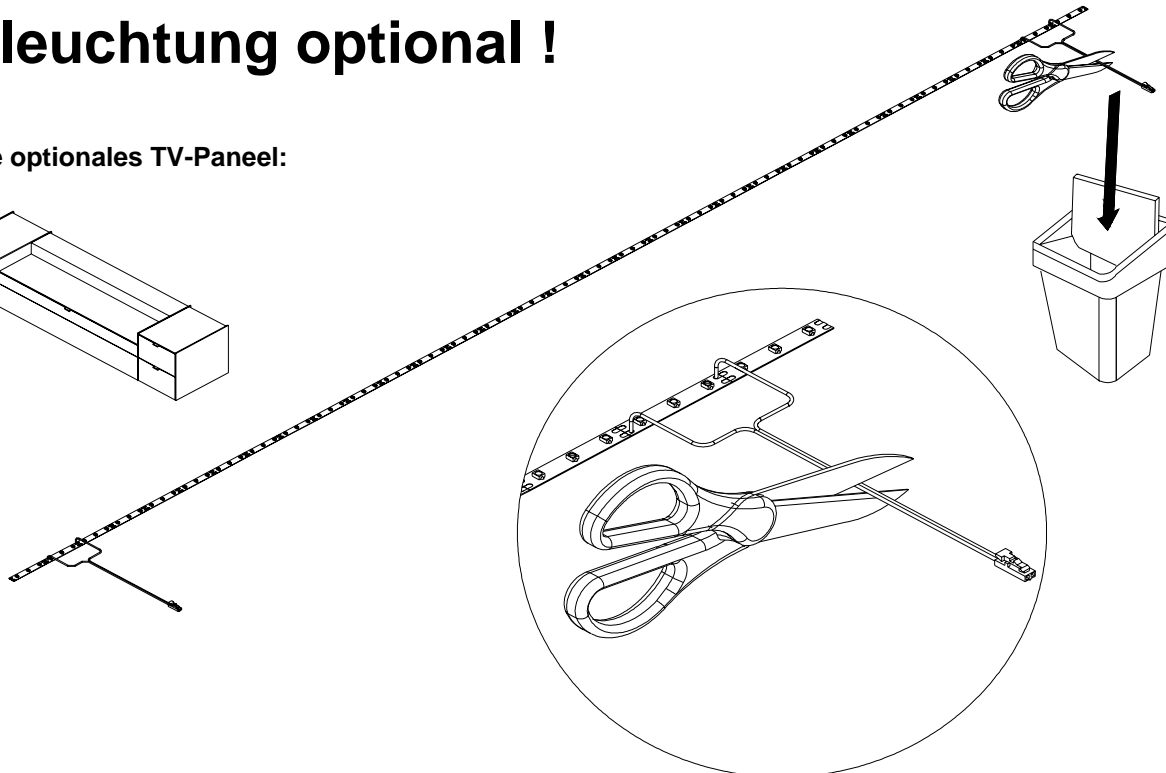
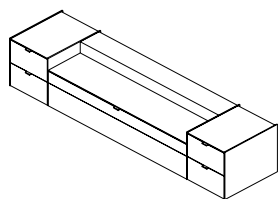

Mit optionalem TV-Panel:

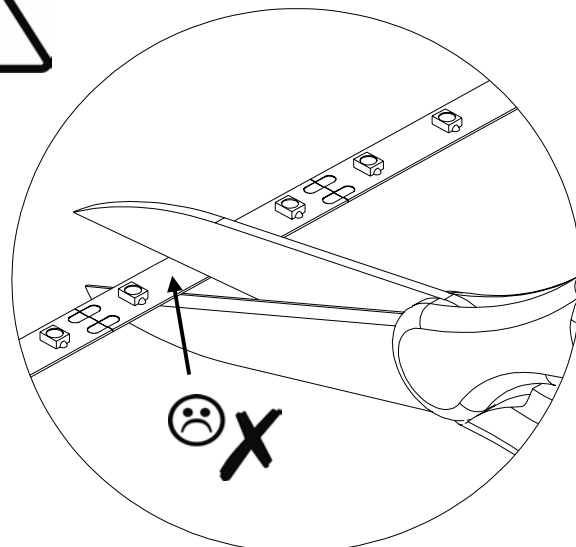
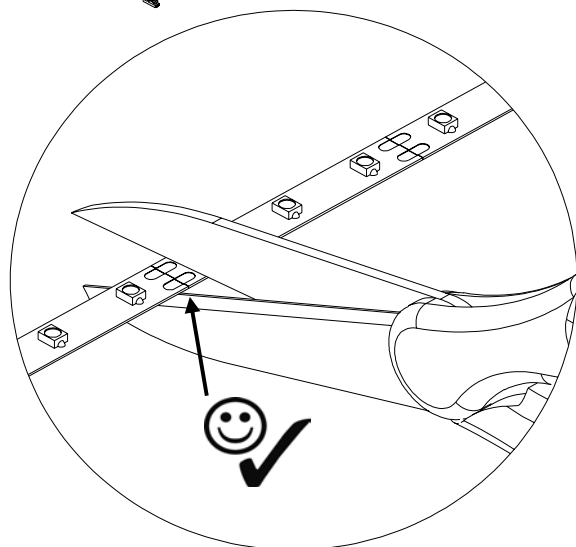
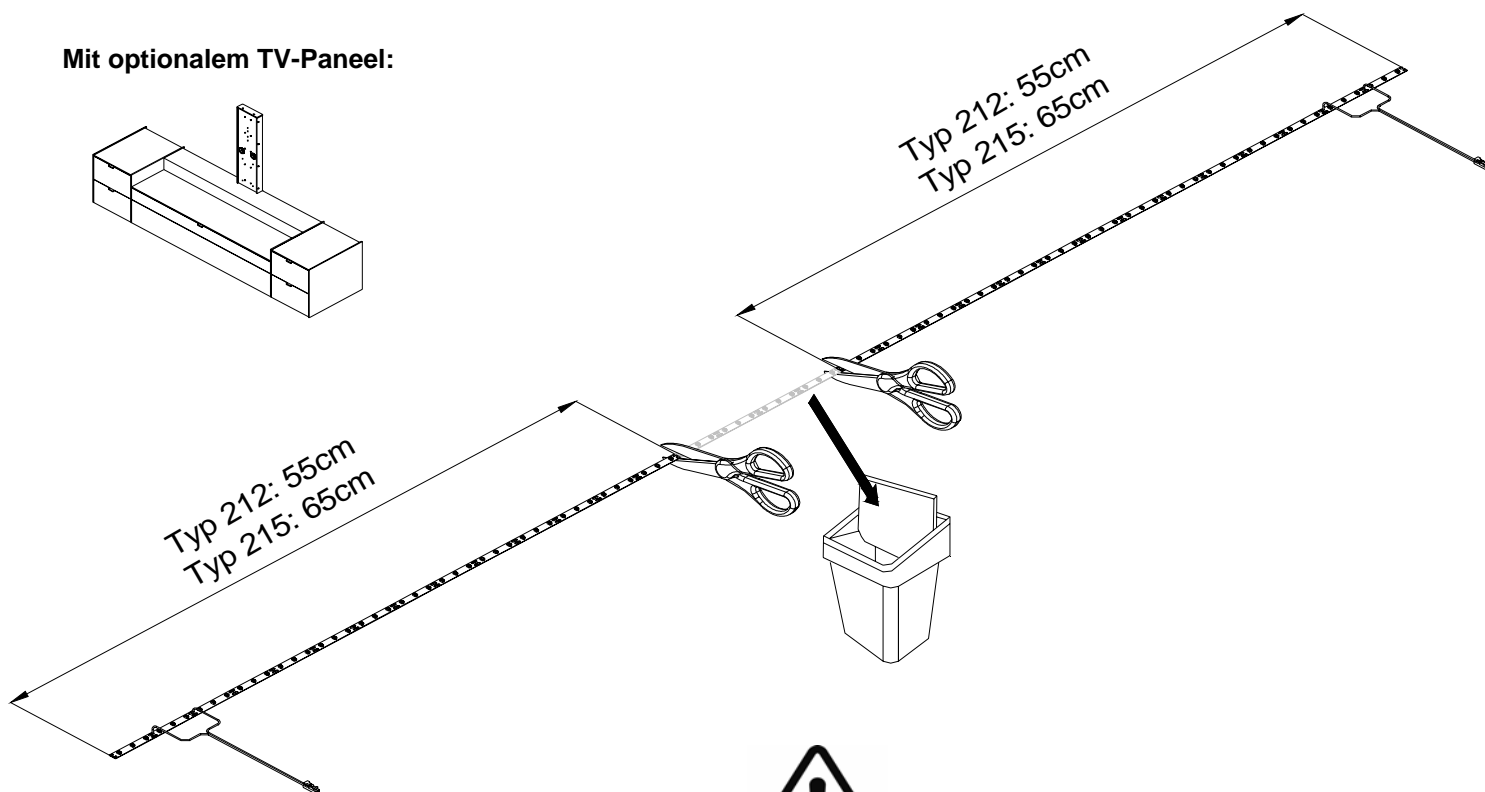
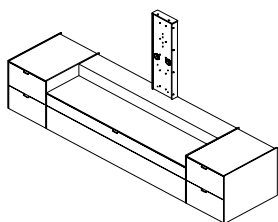

# Beleuchtung optional !

Nicht knicken!  
Do not bend!



**Nicht** die Schutzfolie vom  
Klebeband entfernen  
**Do not** remove protectiv foil  
from the adhesive tape

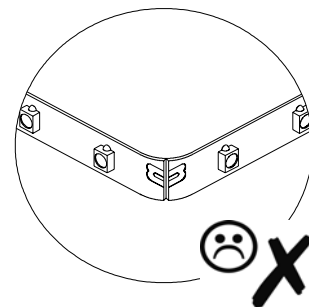
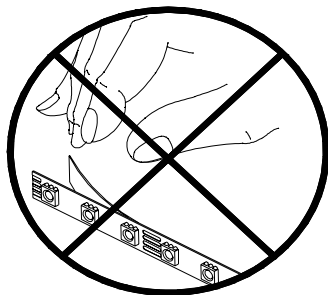

Ohne optionales TV-Paneel:

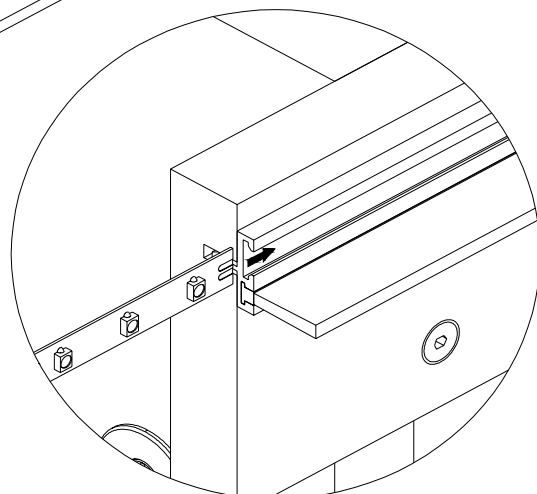
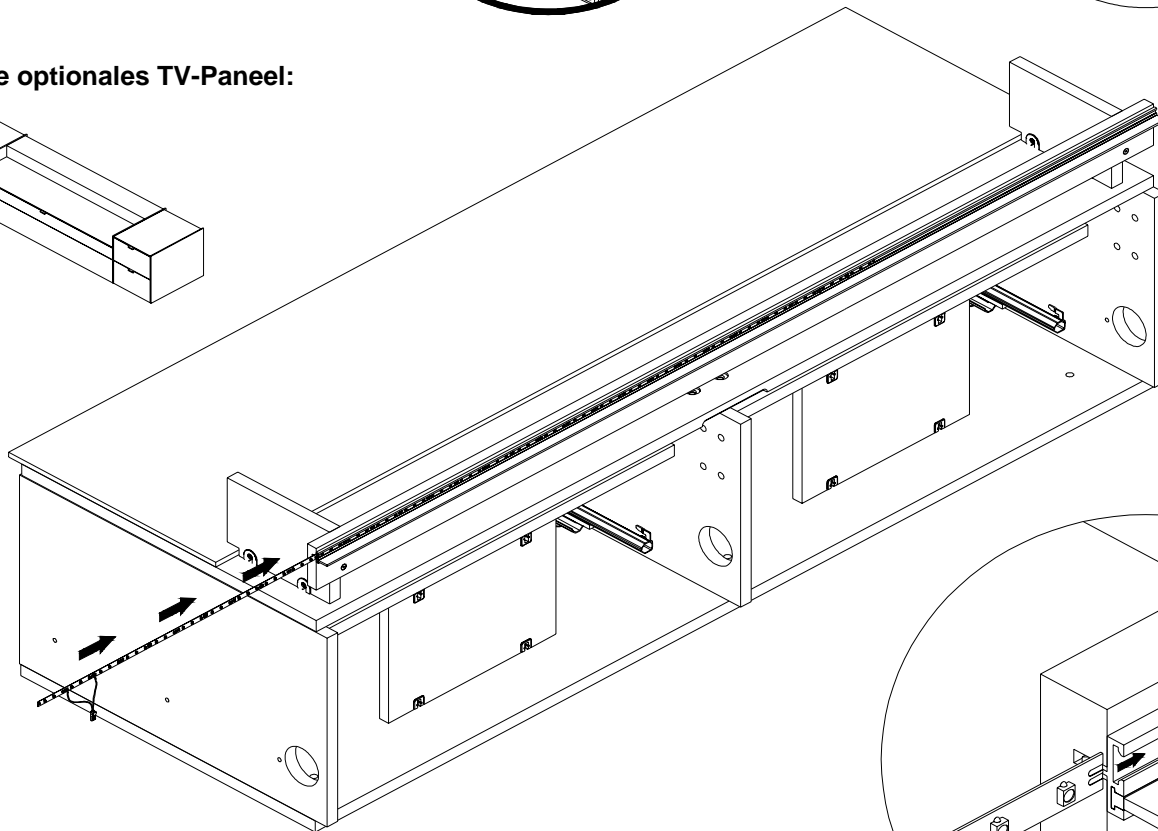
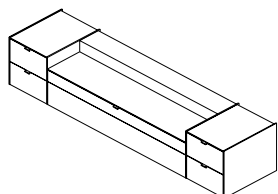

Mit optionalem TV-Paneel:

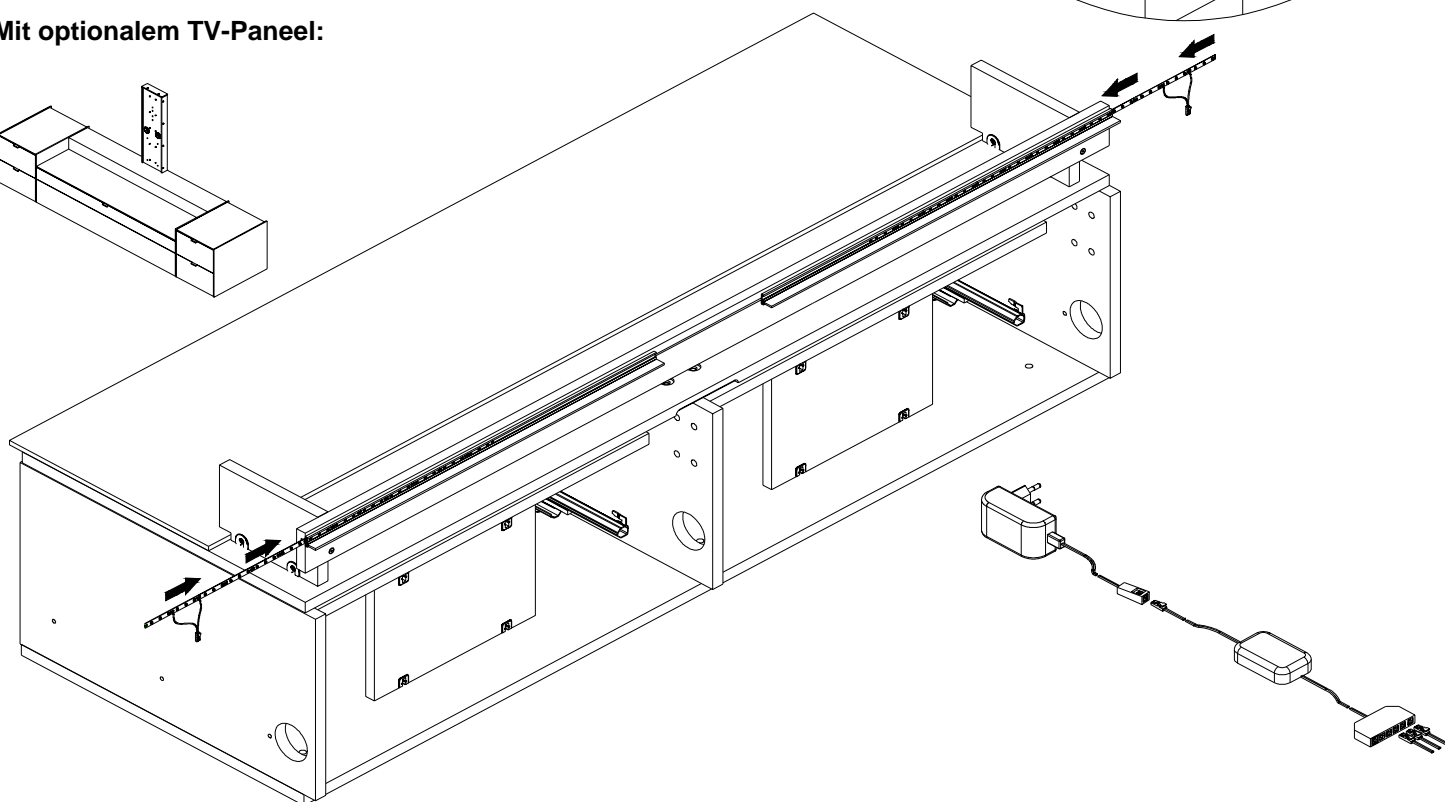
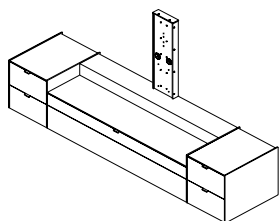

**Ohne optionales TV-Panel:**

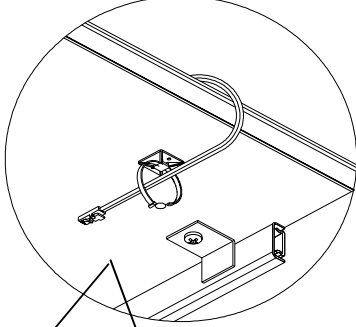
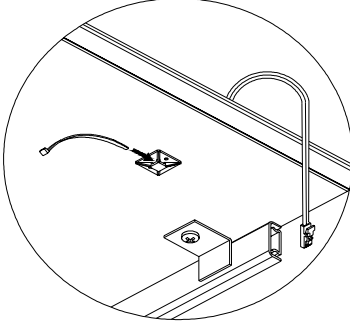
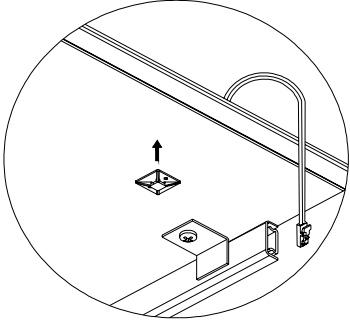
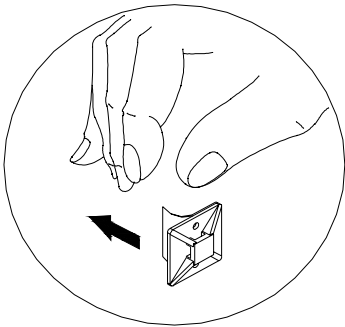
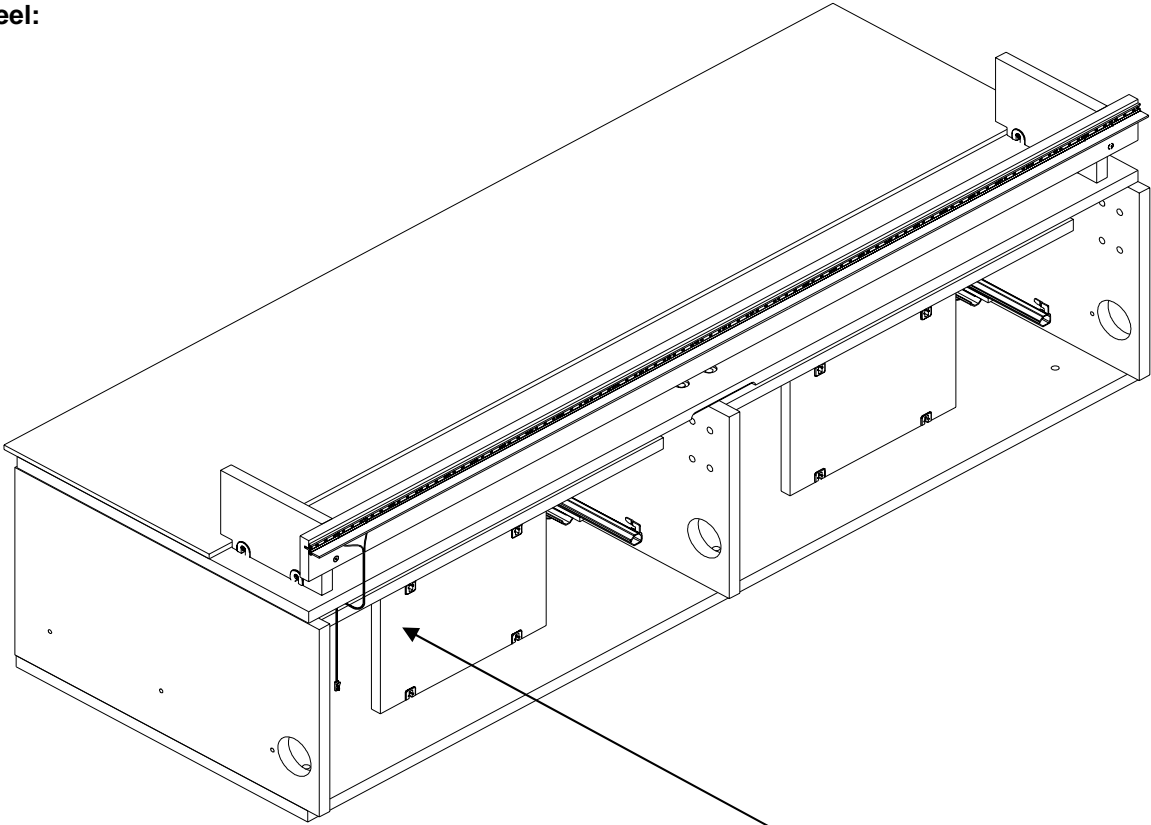
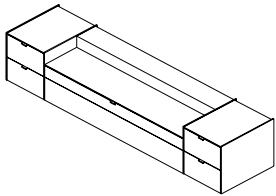

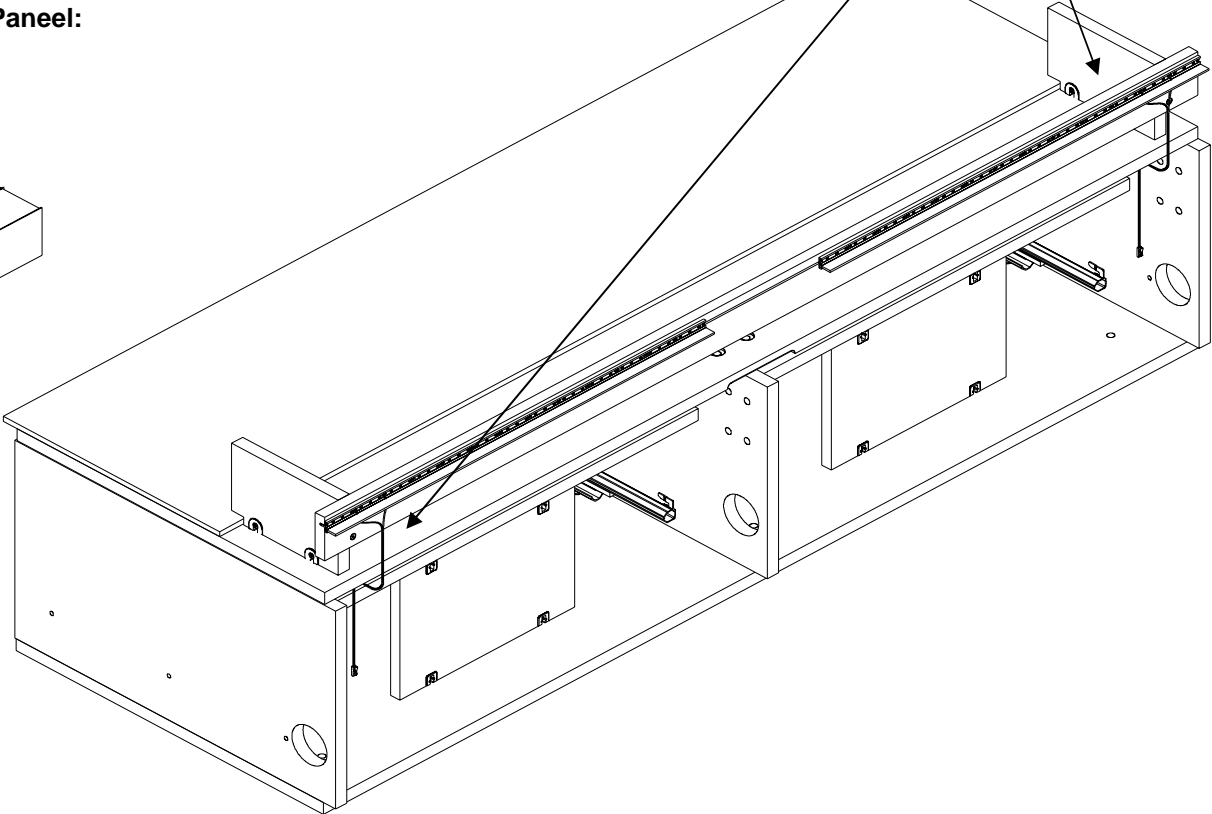
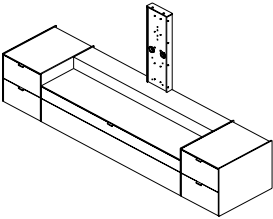

**Mit optionalem TV-Panel:**



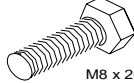

# TV-Panel optional !

<b>J22</b>	<b>BT1415</b>
	
M6 x 10	
<b>4x</b>	

<b>J23</b>	<b>BT1410</b>
	
M8 x 20	
<b>8x</b>	

<b>Q4</b>	<b>MM1014</b>
	
4,0 x 17	
<b>4x</b>	

<b>X31</b>	<b>MM1140</b>
	
M8	
<b>8x</b>	

<b>H2</b>	<b>ZU1276</b>
	
<b>4x</b>	

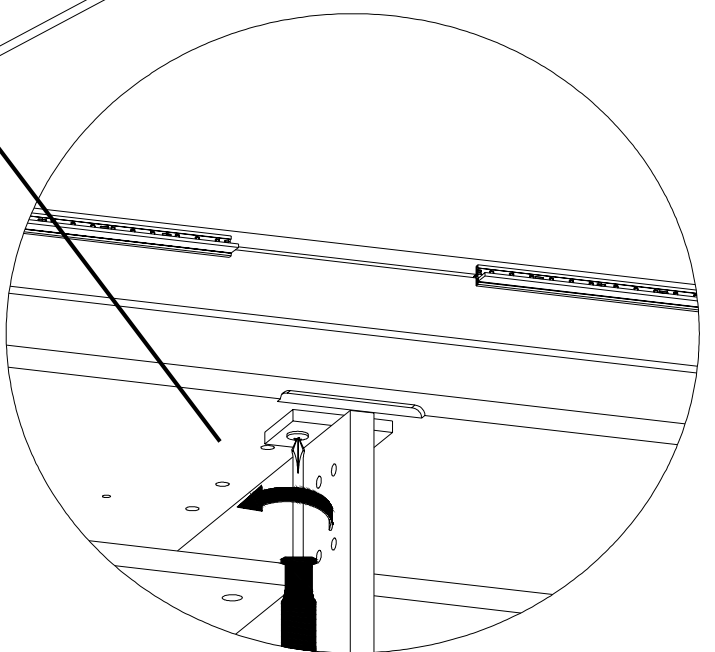
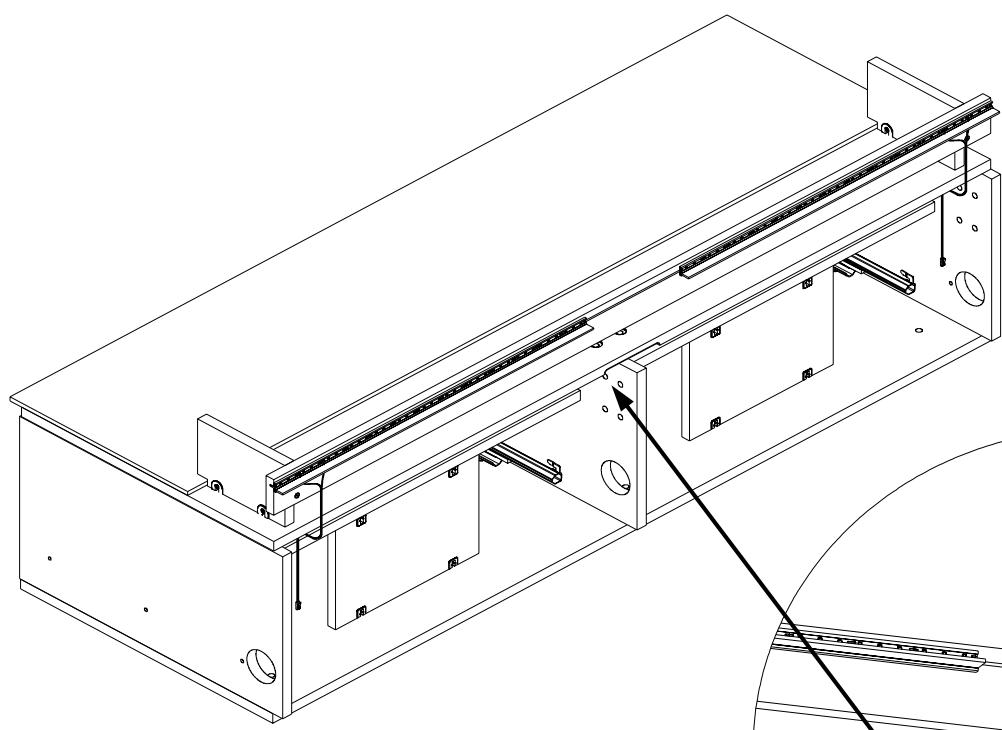
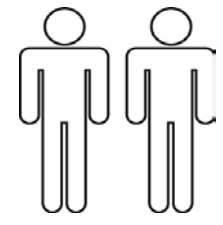
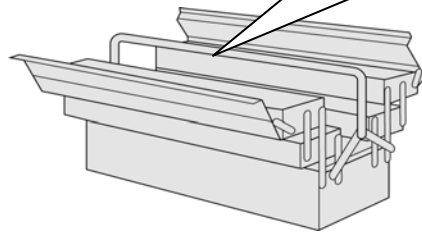
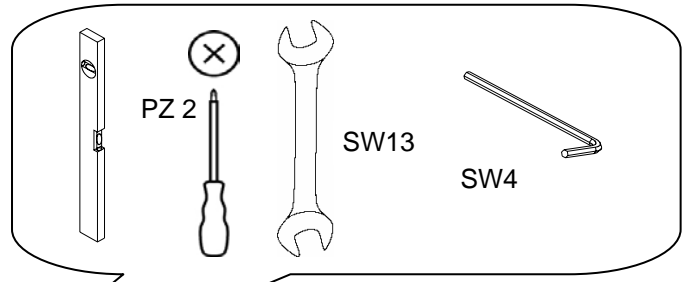
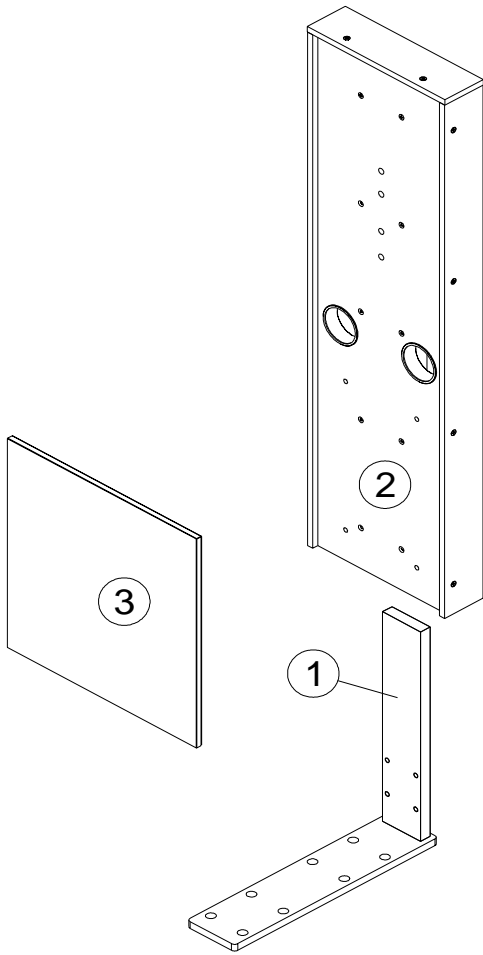

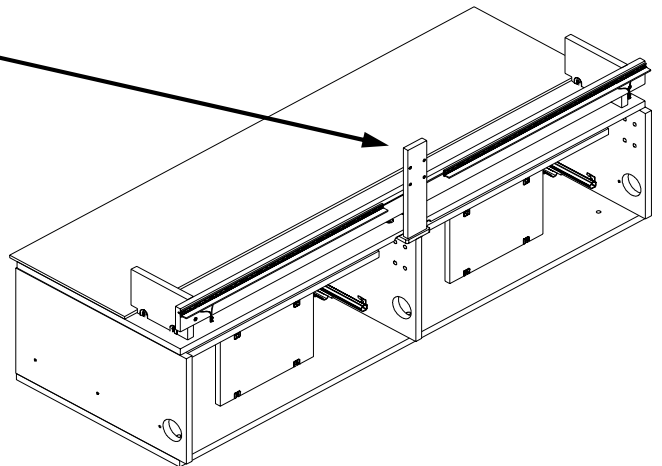
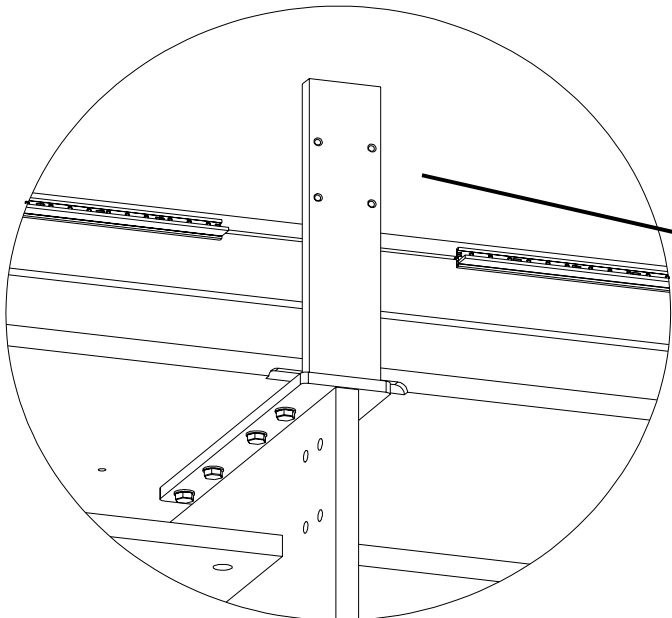
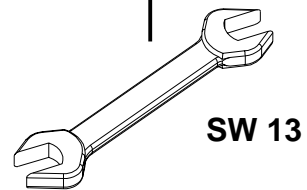
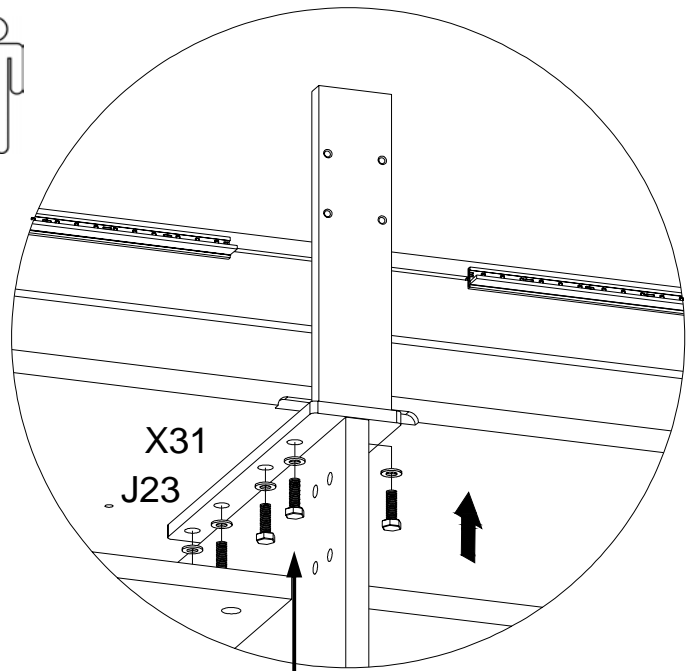
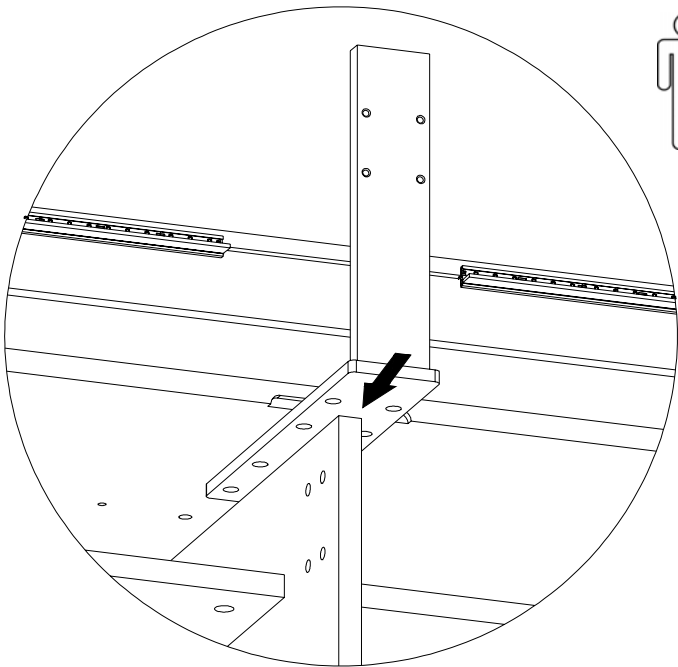
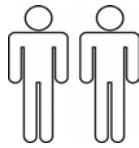
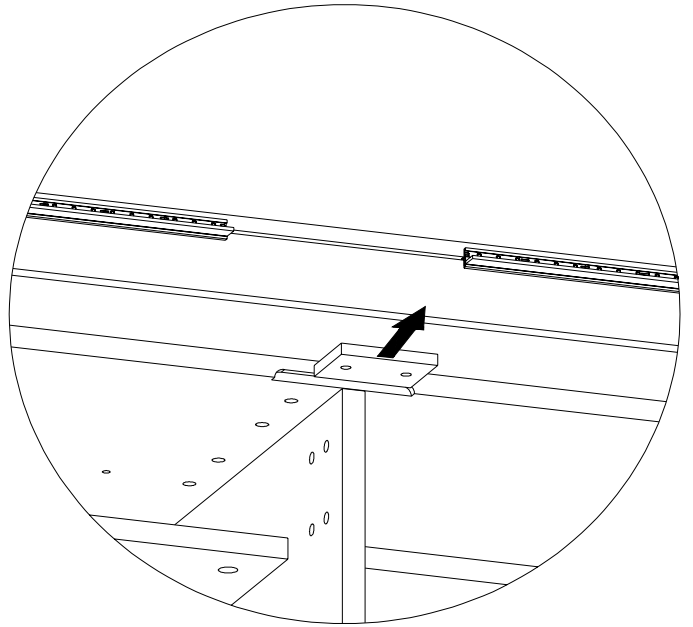
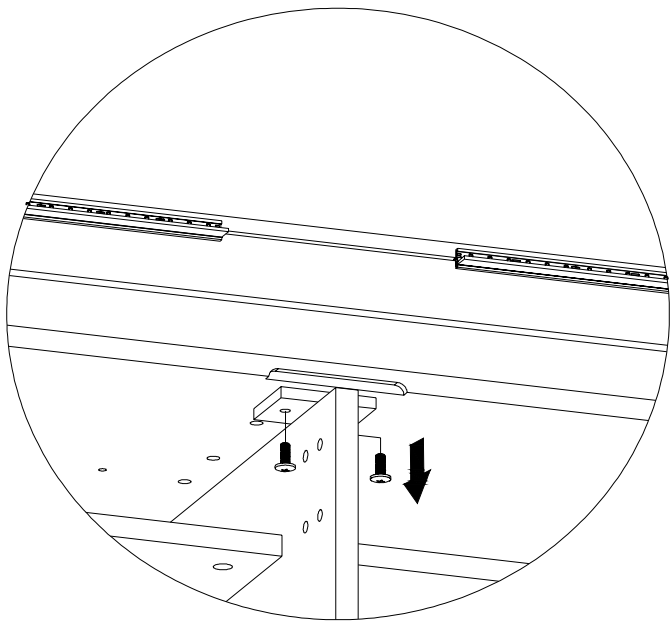

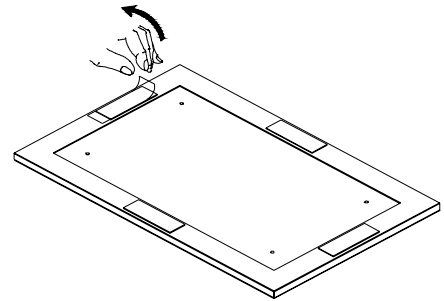
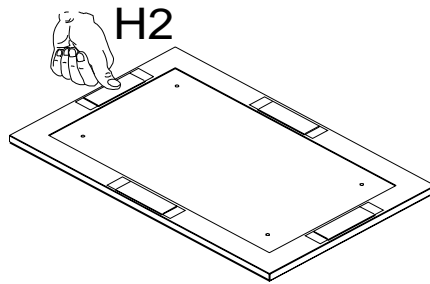
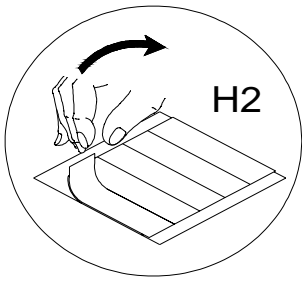

**Die Schrauben zur Befestigung  
der Rückwand nur mit einem  
Handschraubendreher anziehen.  
Keinen Elektro- oder Akkuschrauber  
verwenden.**

**Only use a hand screwdriver  
to attach the screws .  
Do not use an electric or  
cordless screwdriver.**

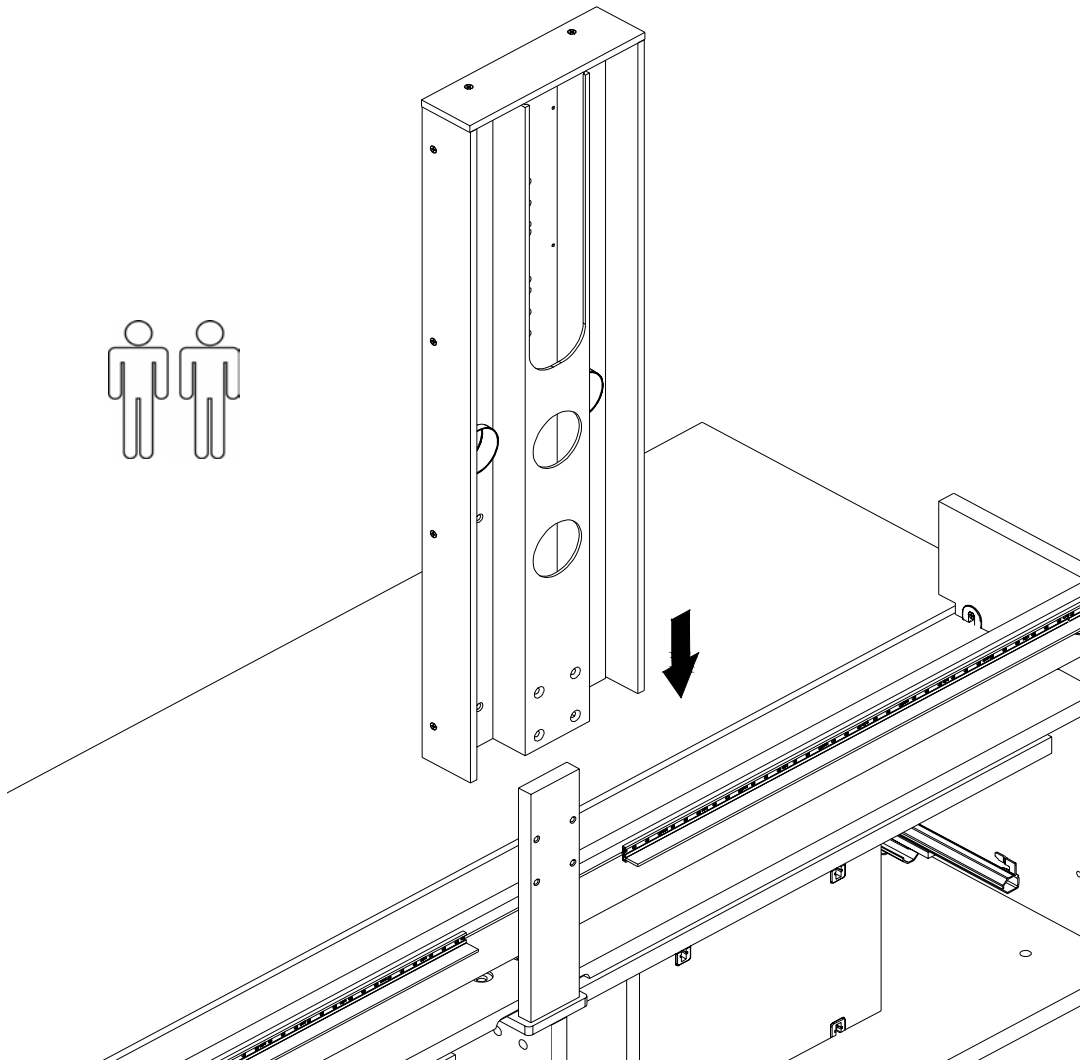
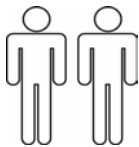
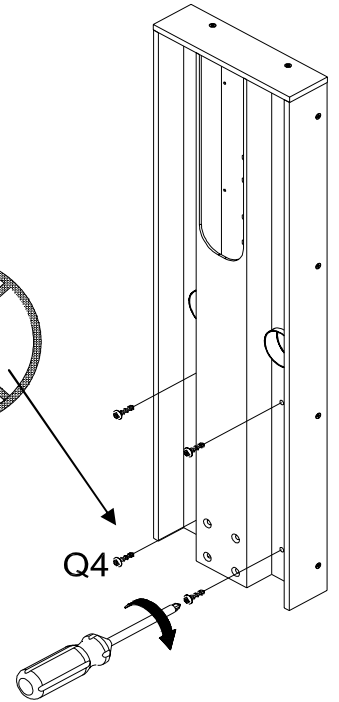
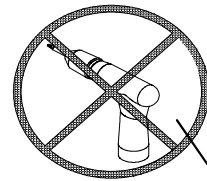
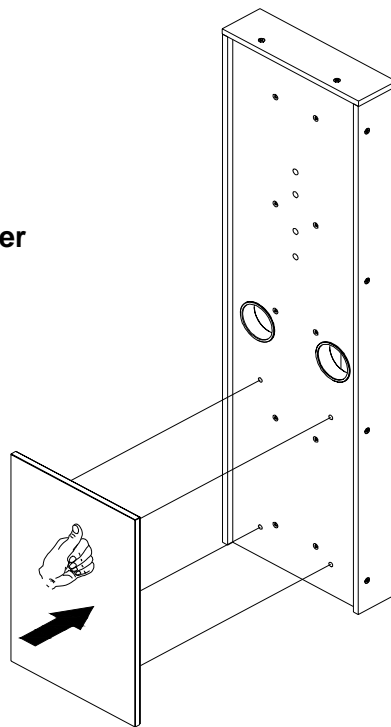

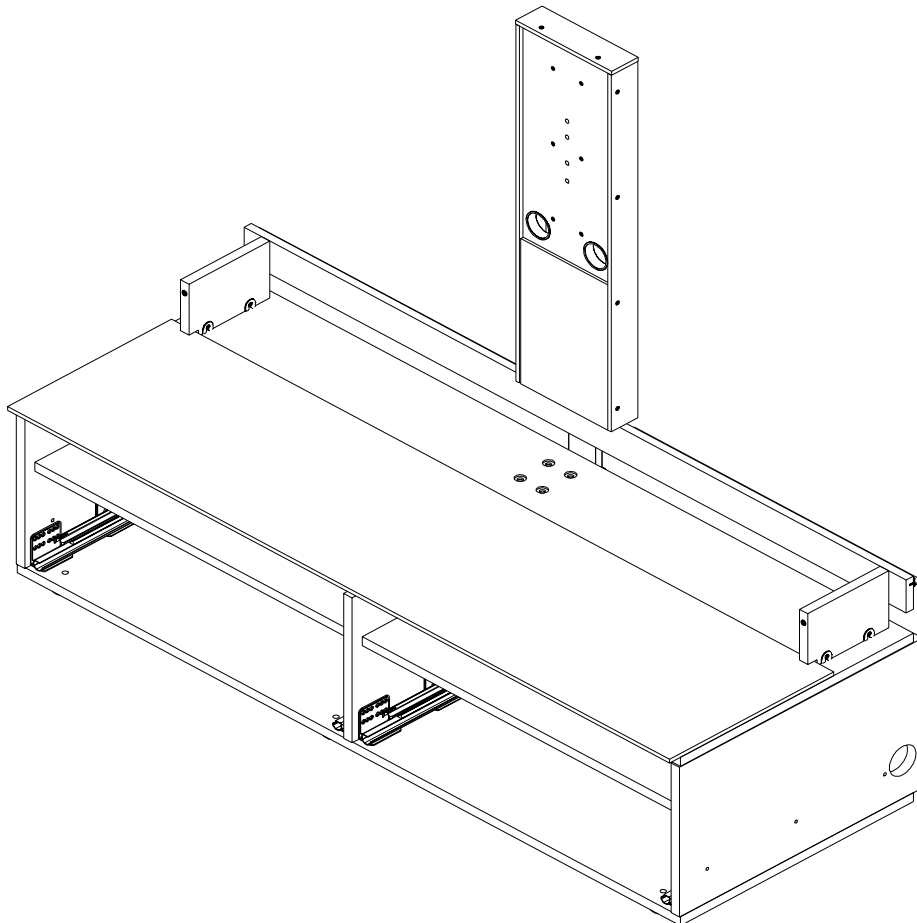
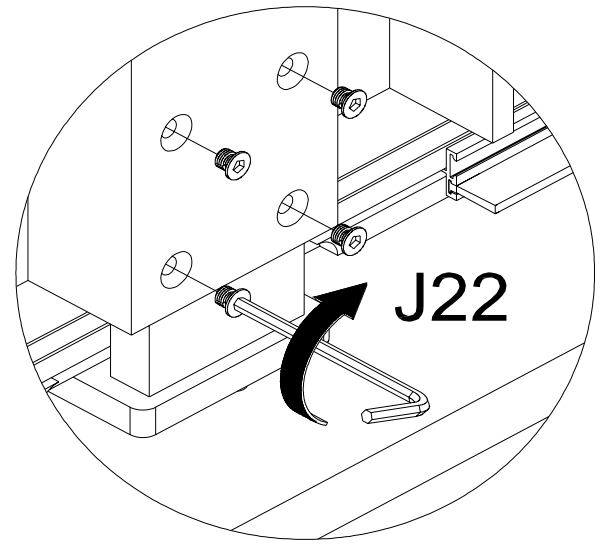
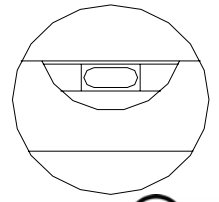
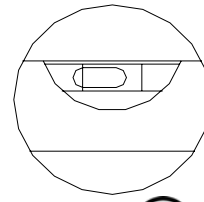
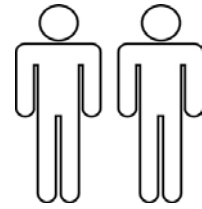
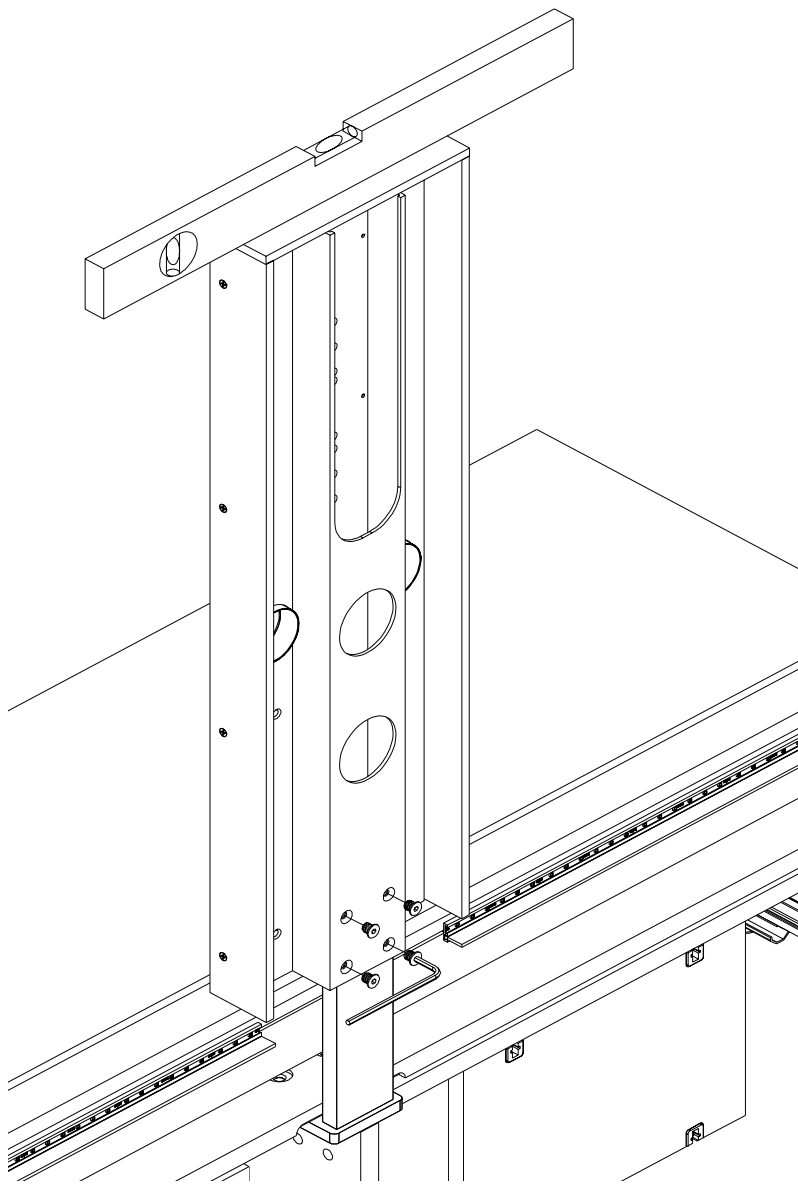



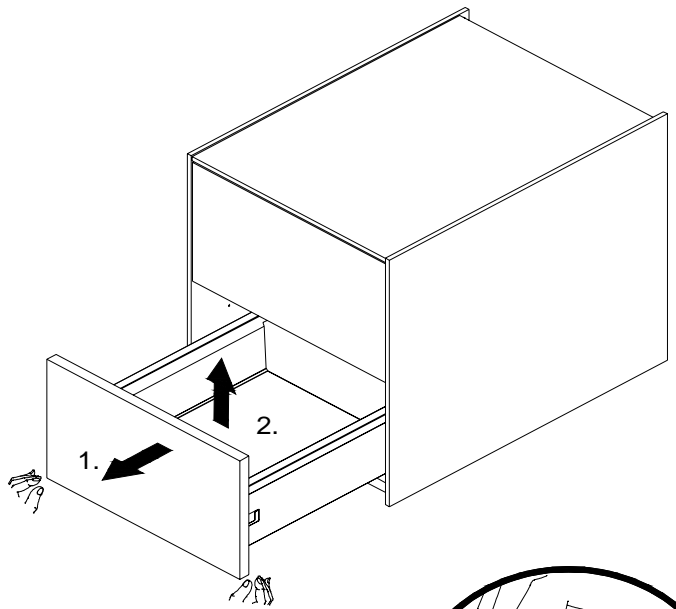
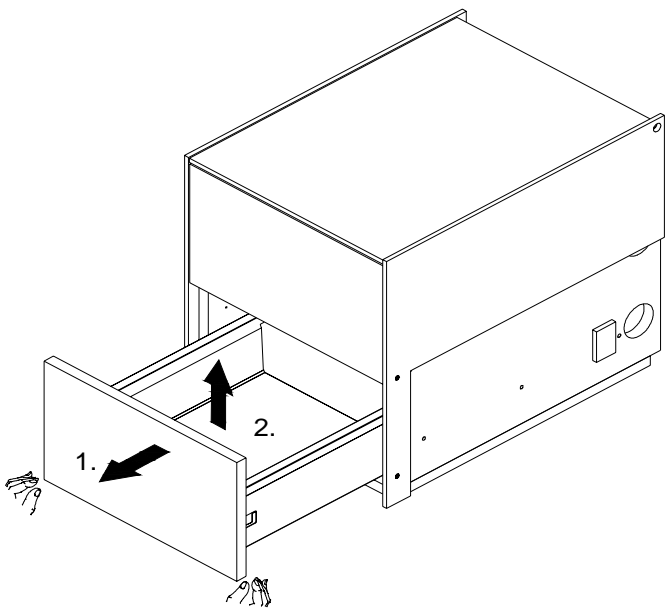

**Beleuchtung optional !**



***Nicht* die Schutzfolie vom Klebeband entfernen**  
***Do not* remove protectiv foil from the adhesive tape**

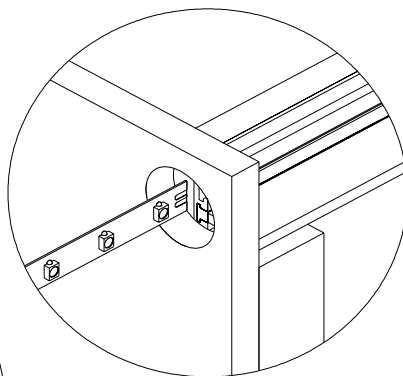
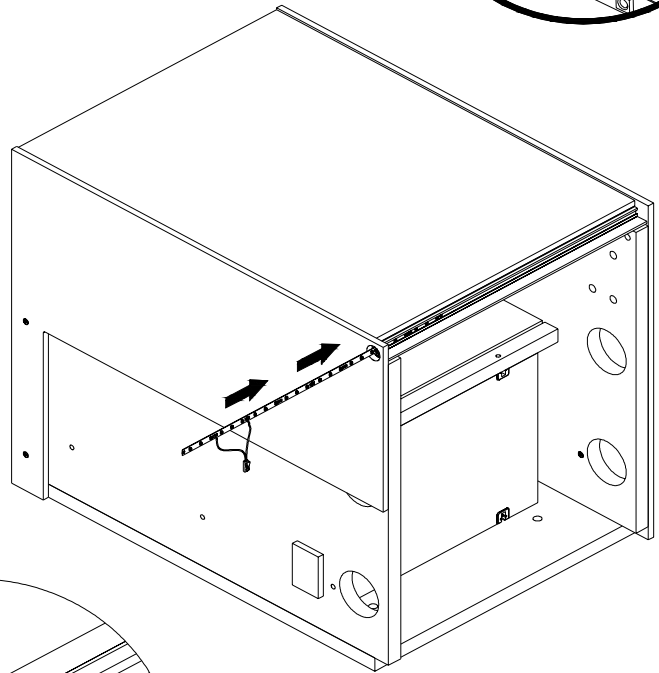
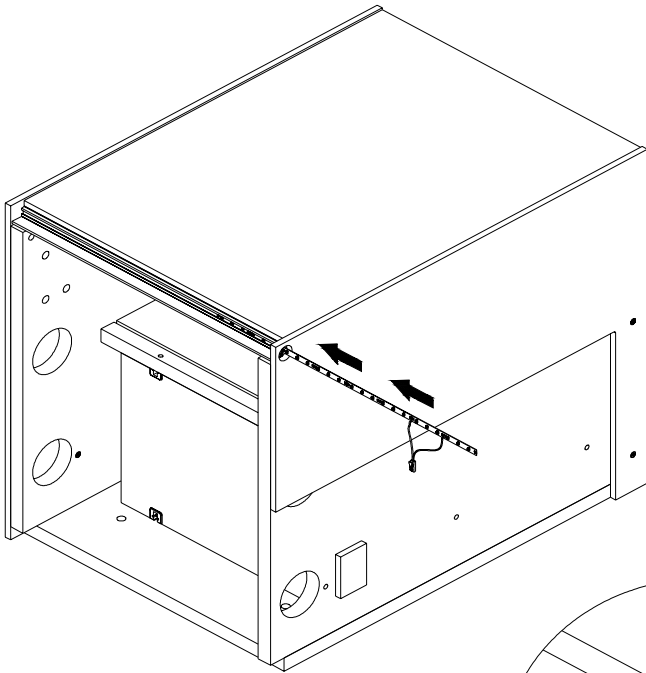
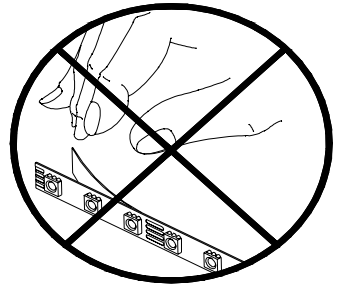

**Nicht knicken!**  
**Do not bend!**

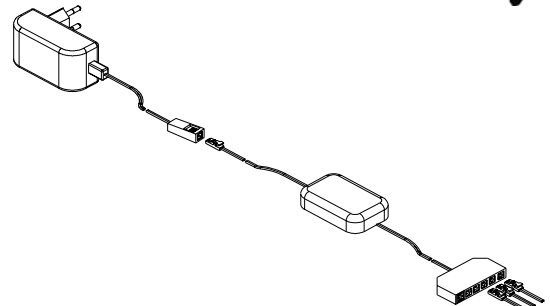
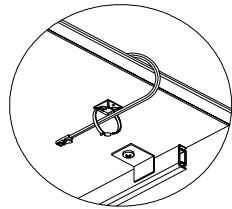
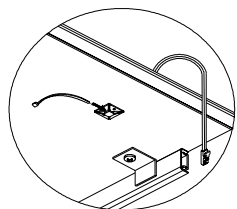
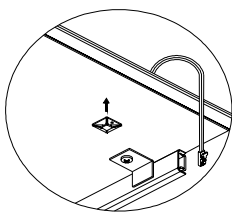
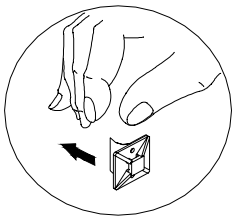
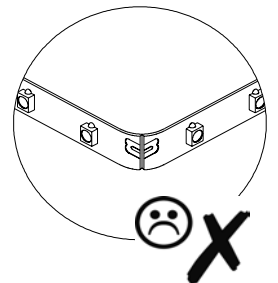

# Mögliche Montagevarianten:

## A: Auf optionalem Fußgestell

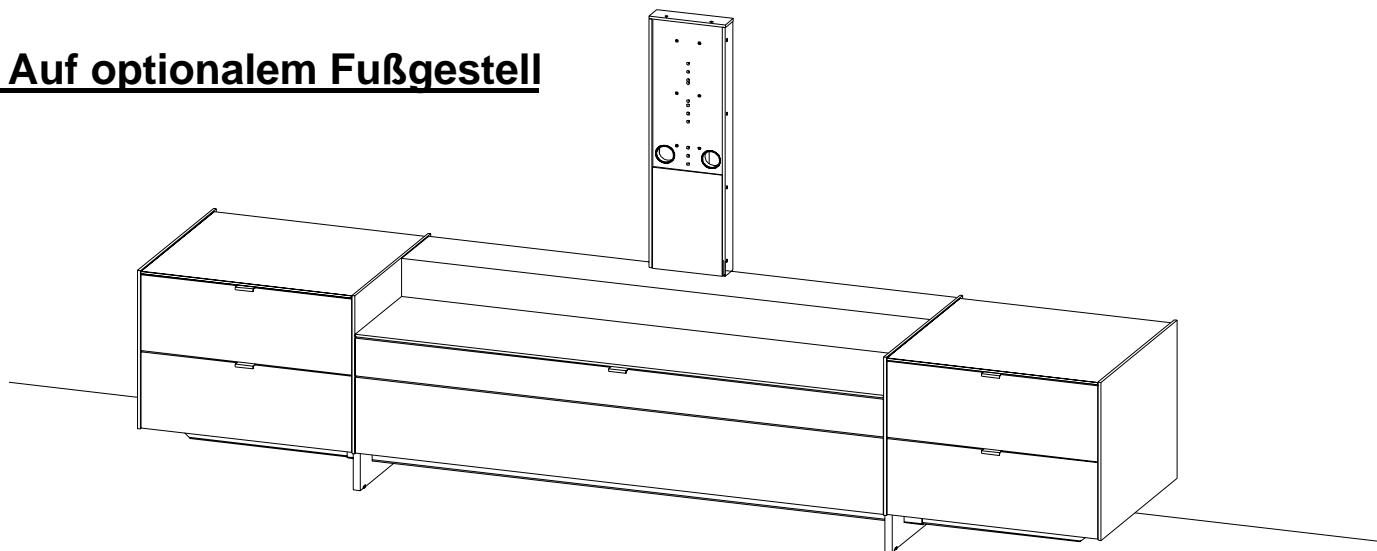

## B: Bodenstehend

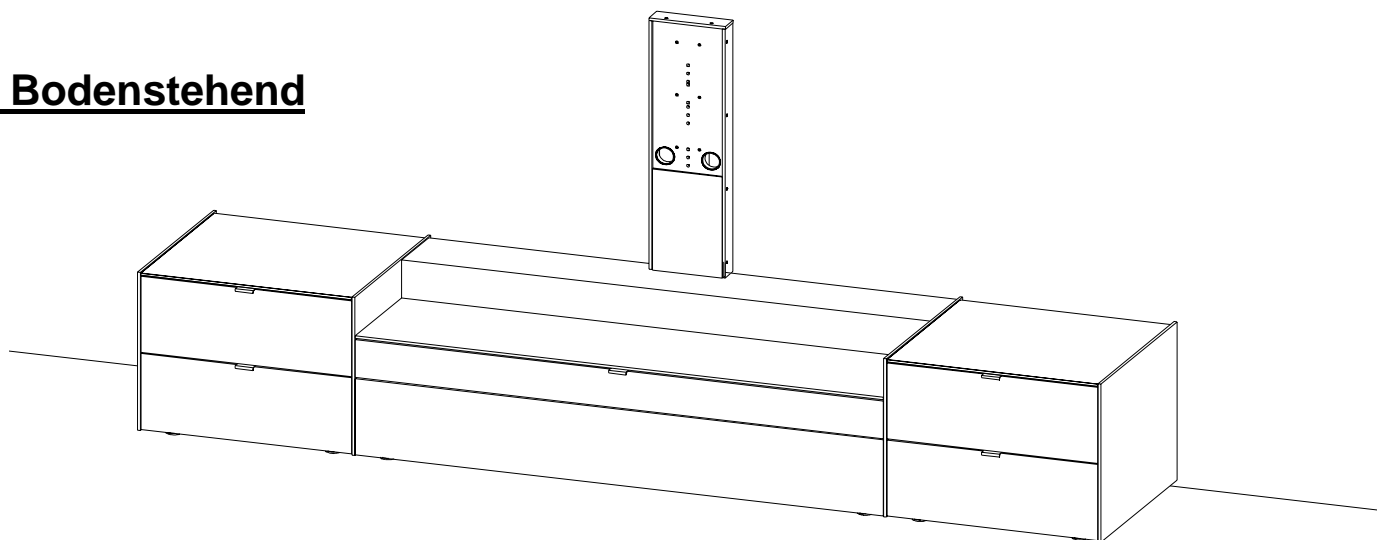

## C: Wandhängend

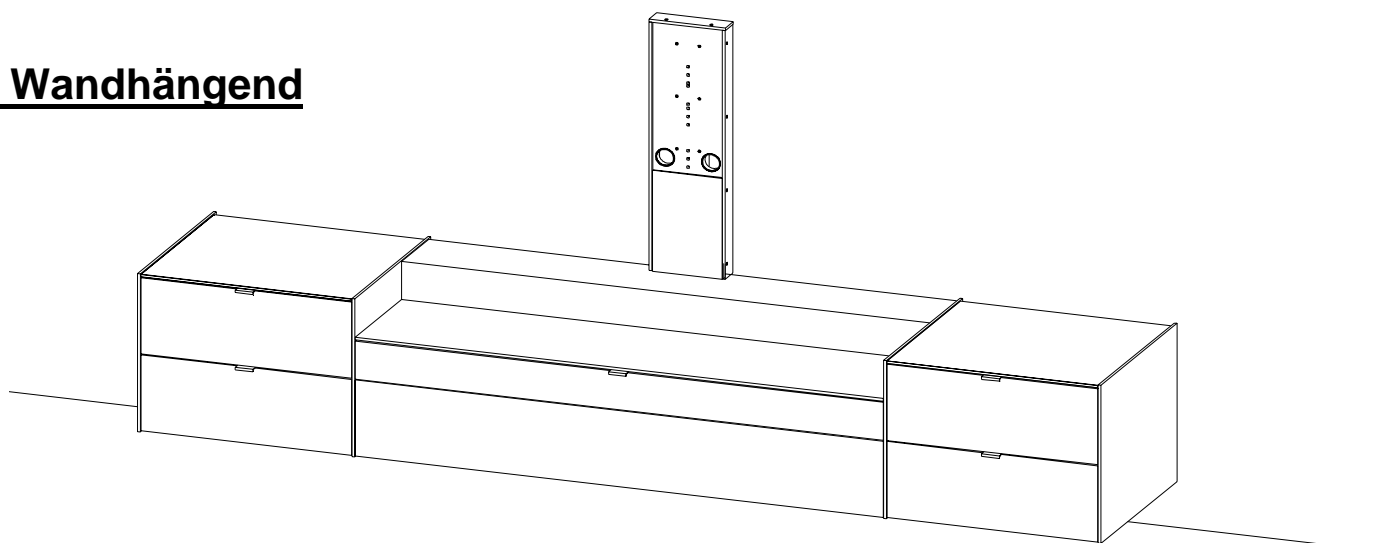

# A: Auf optionalem Fußgestell

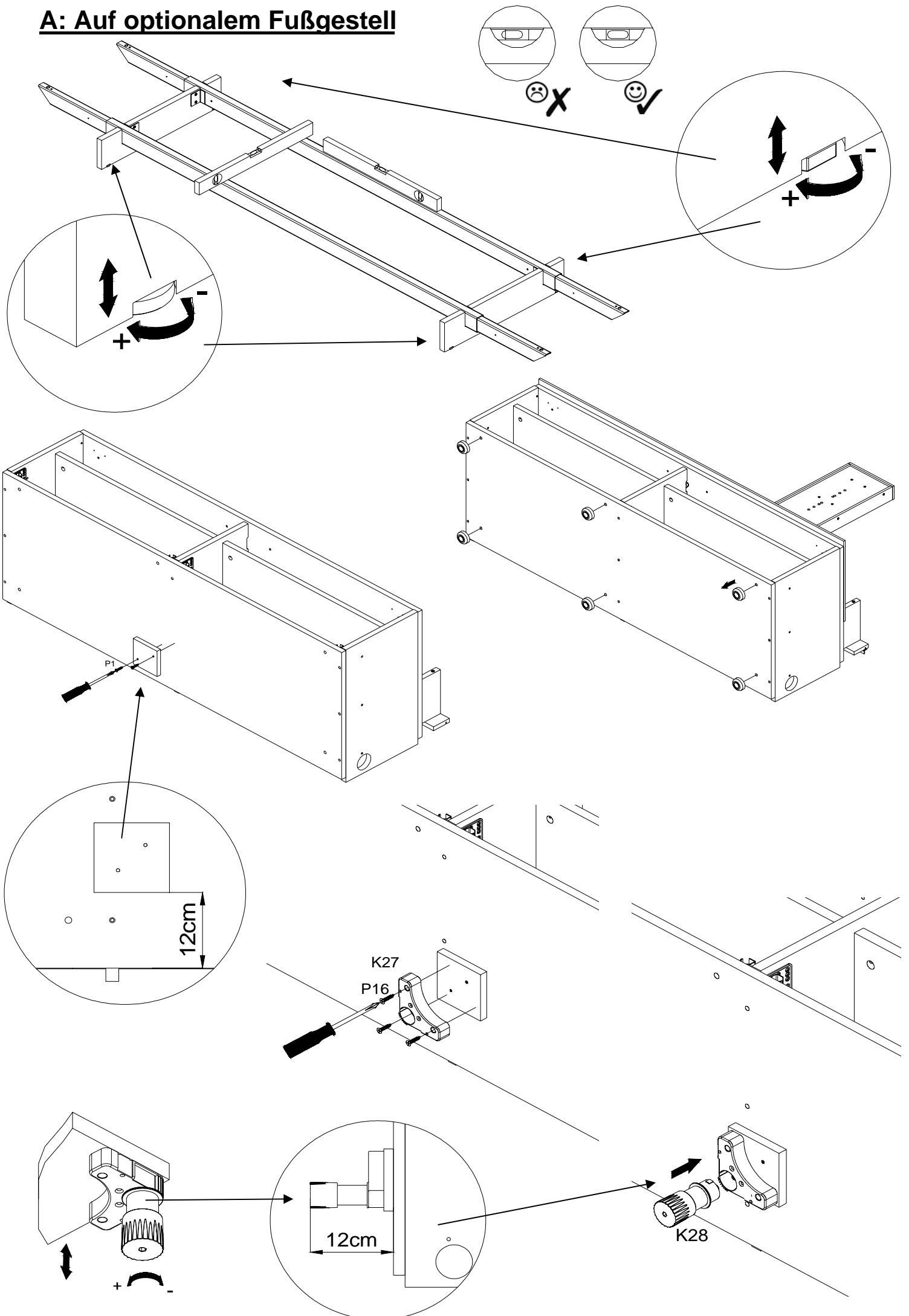

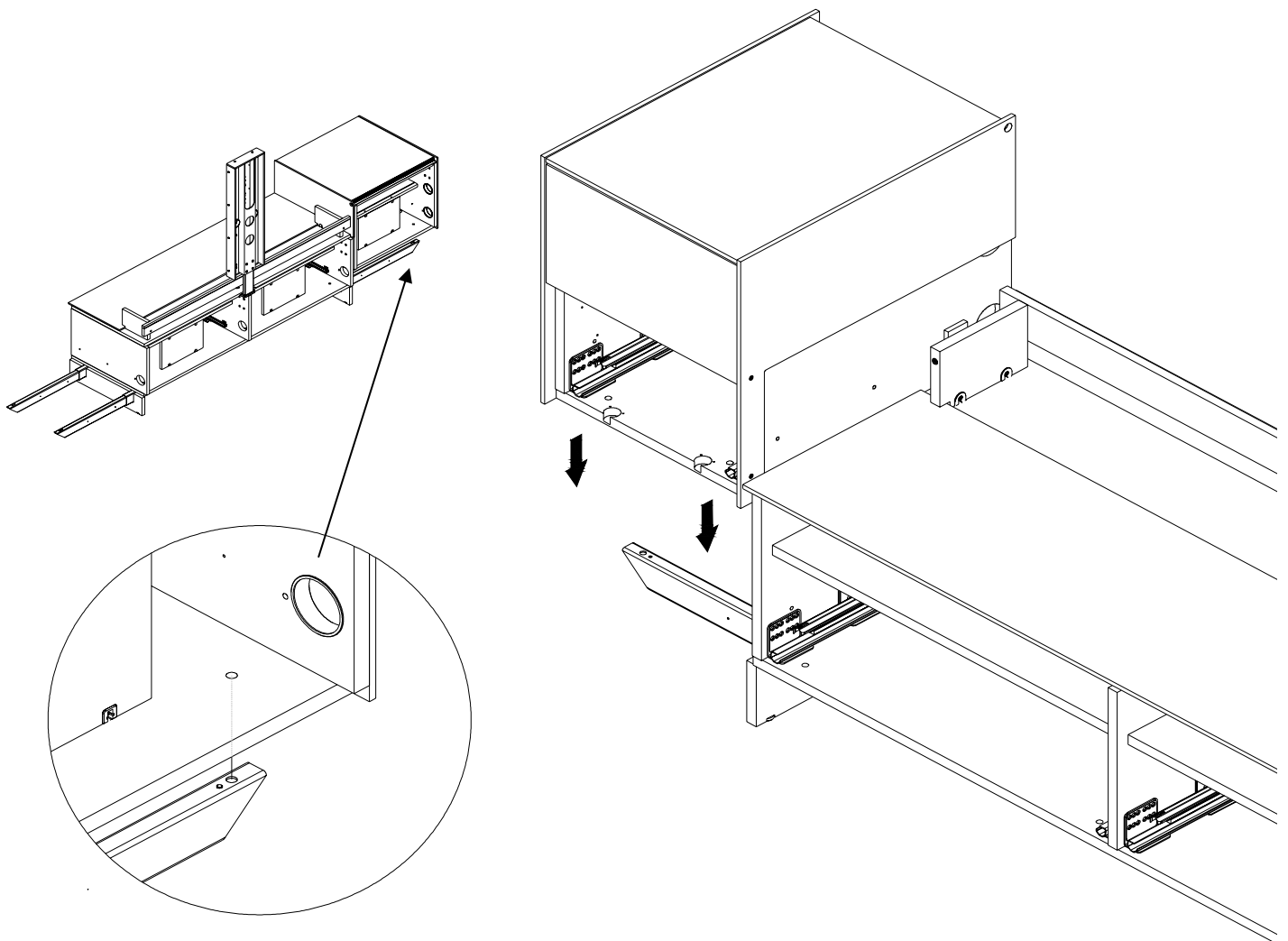
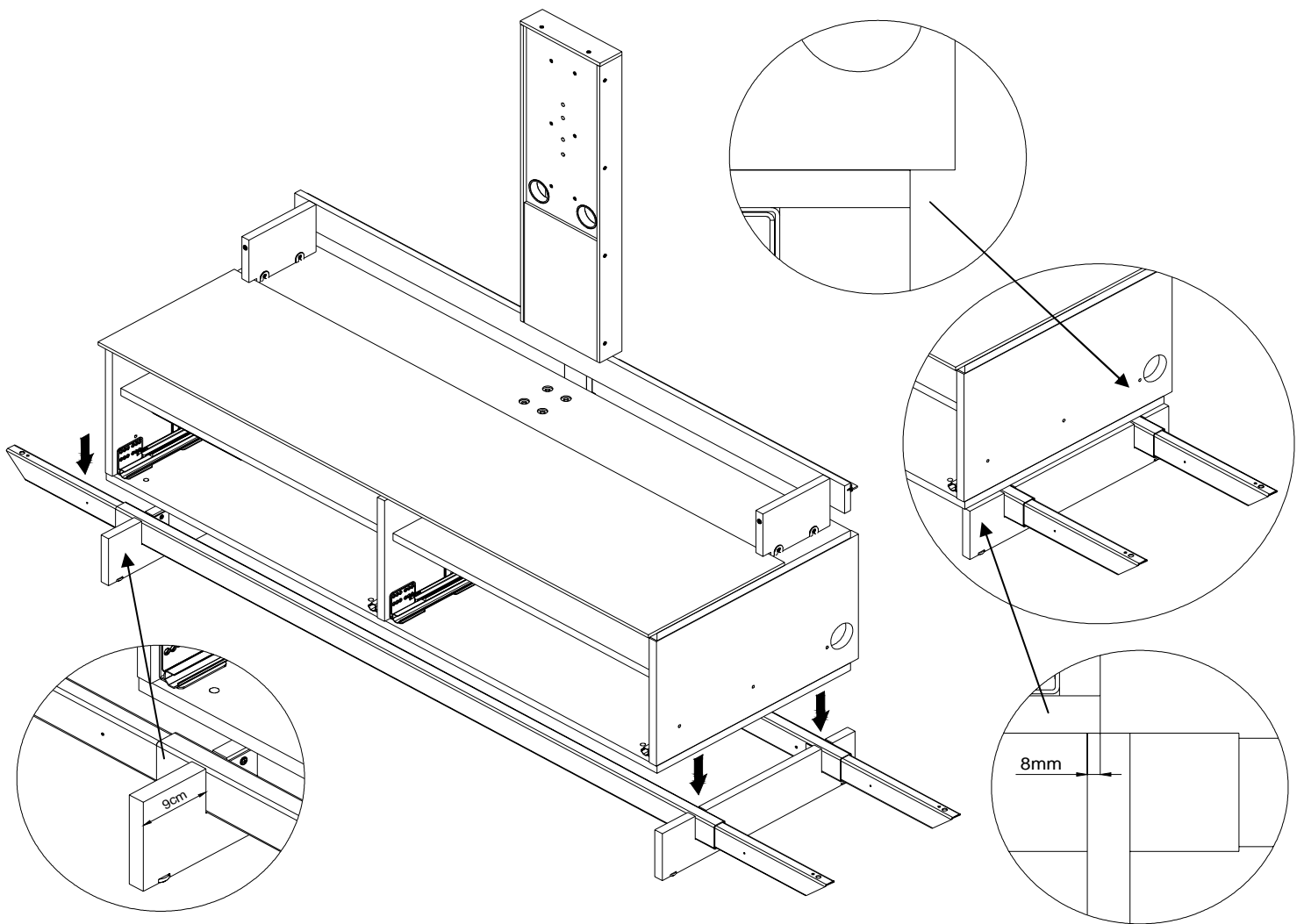

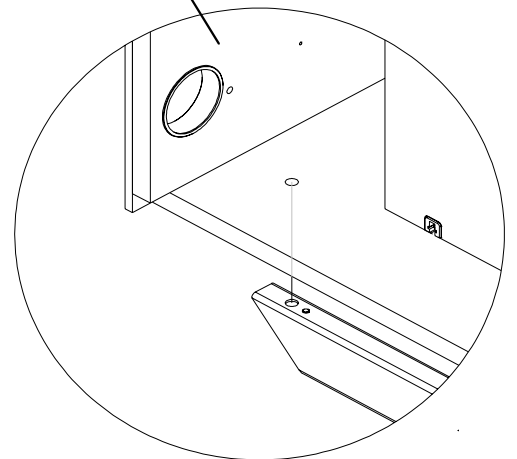
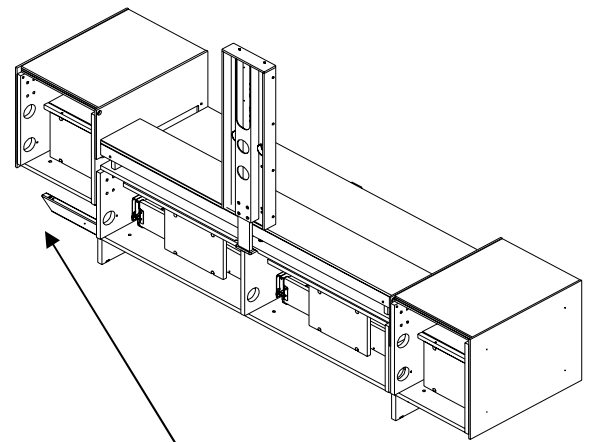
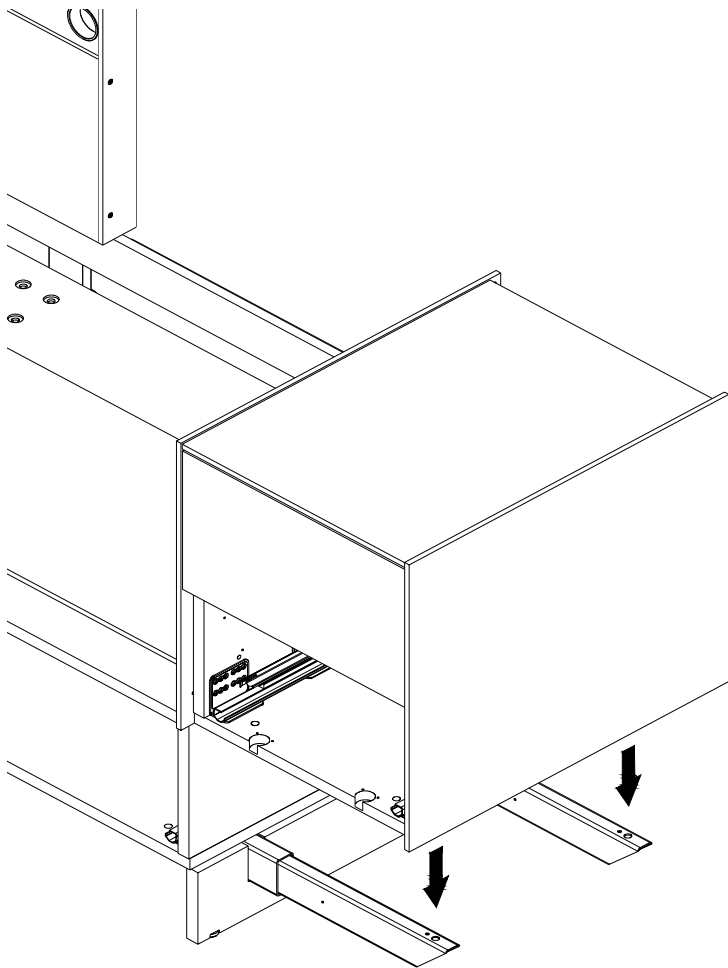
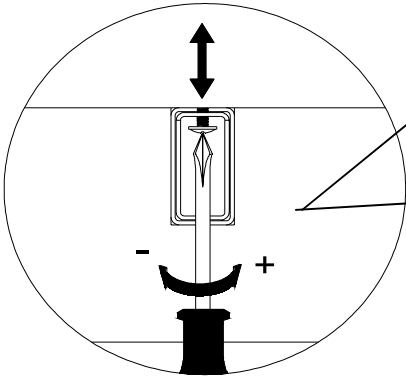
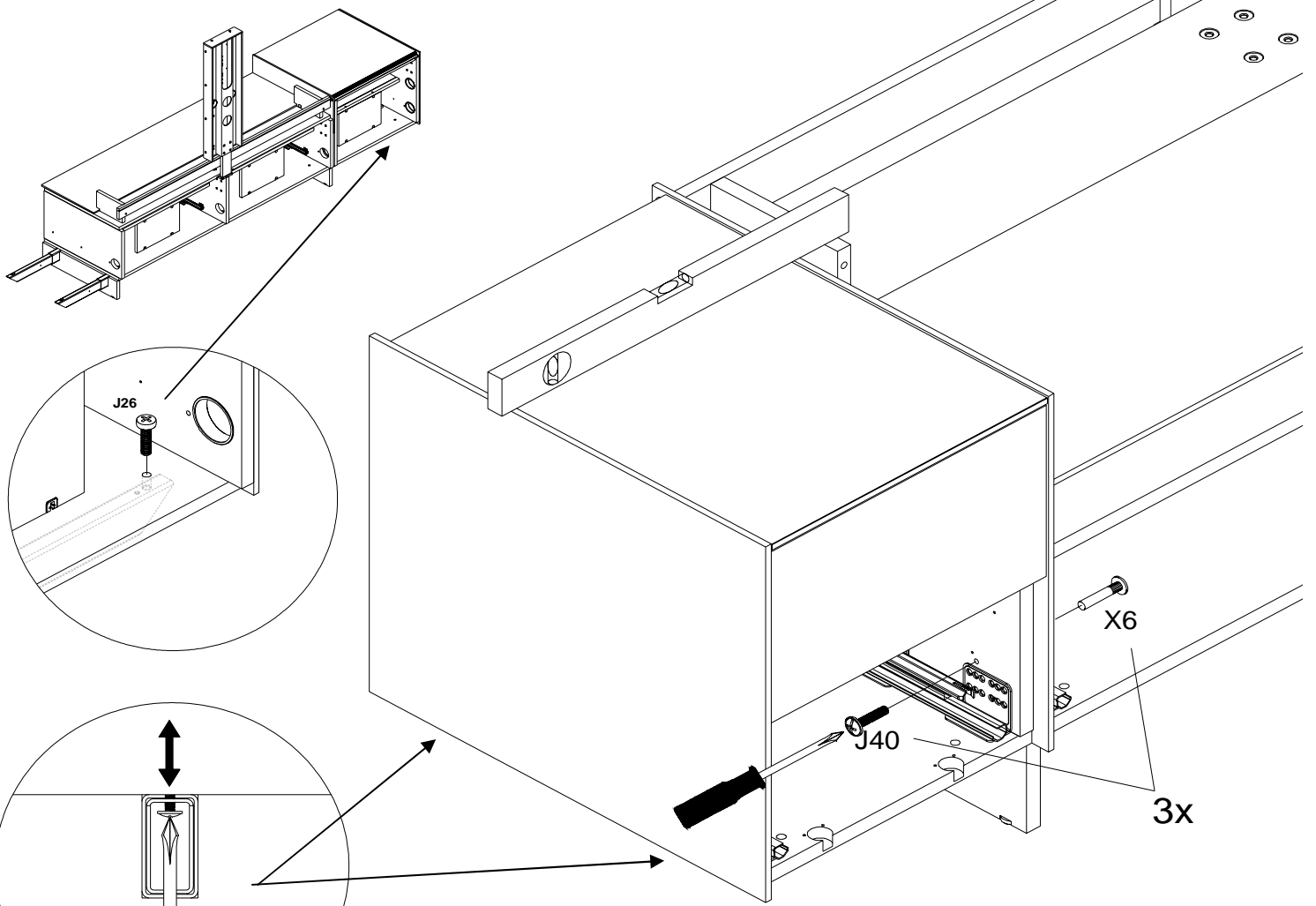

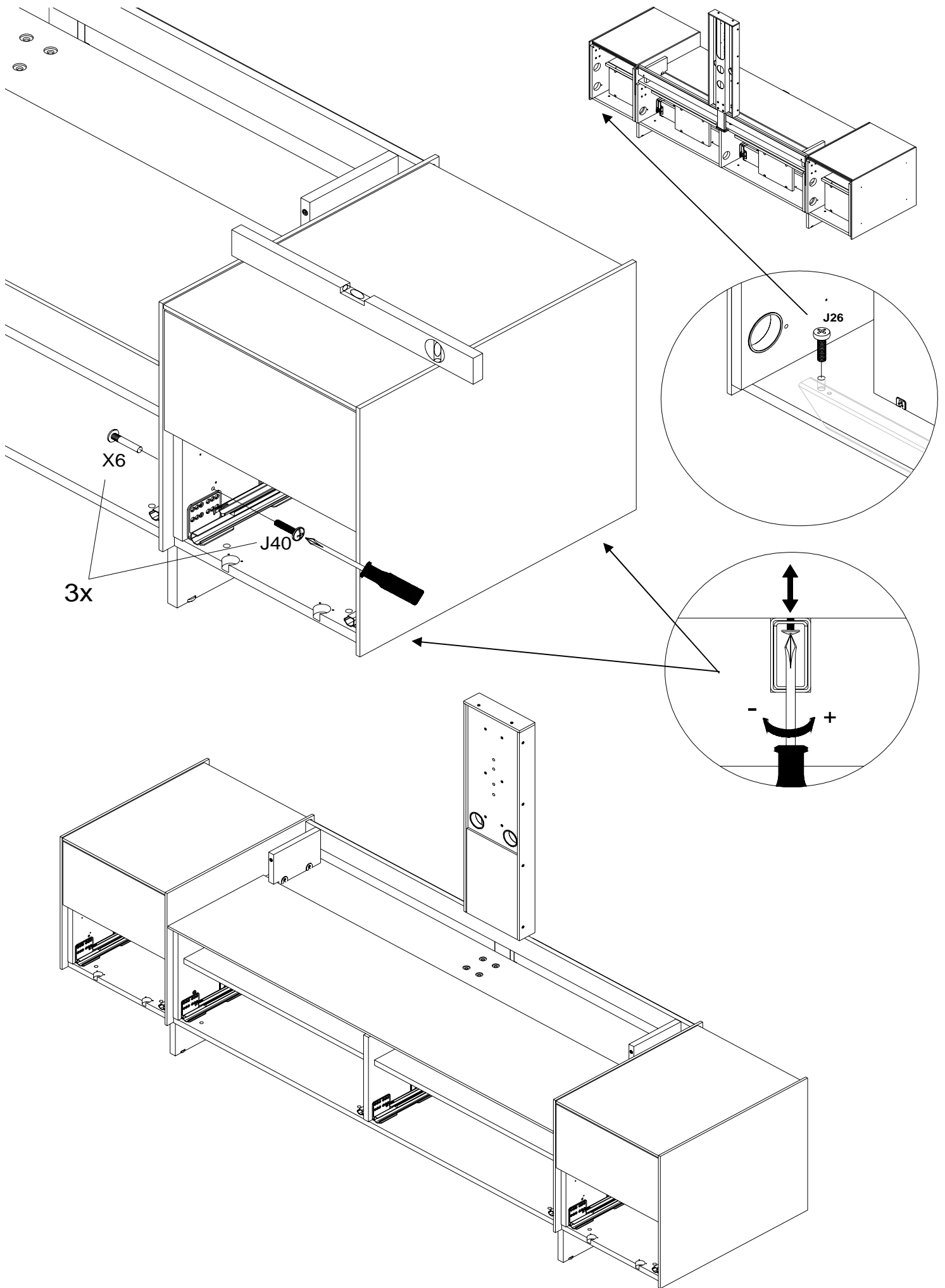

## **B: Bodenstehend**

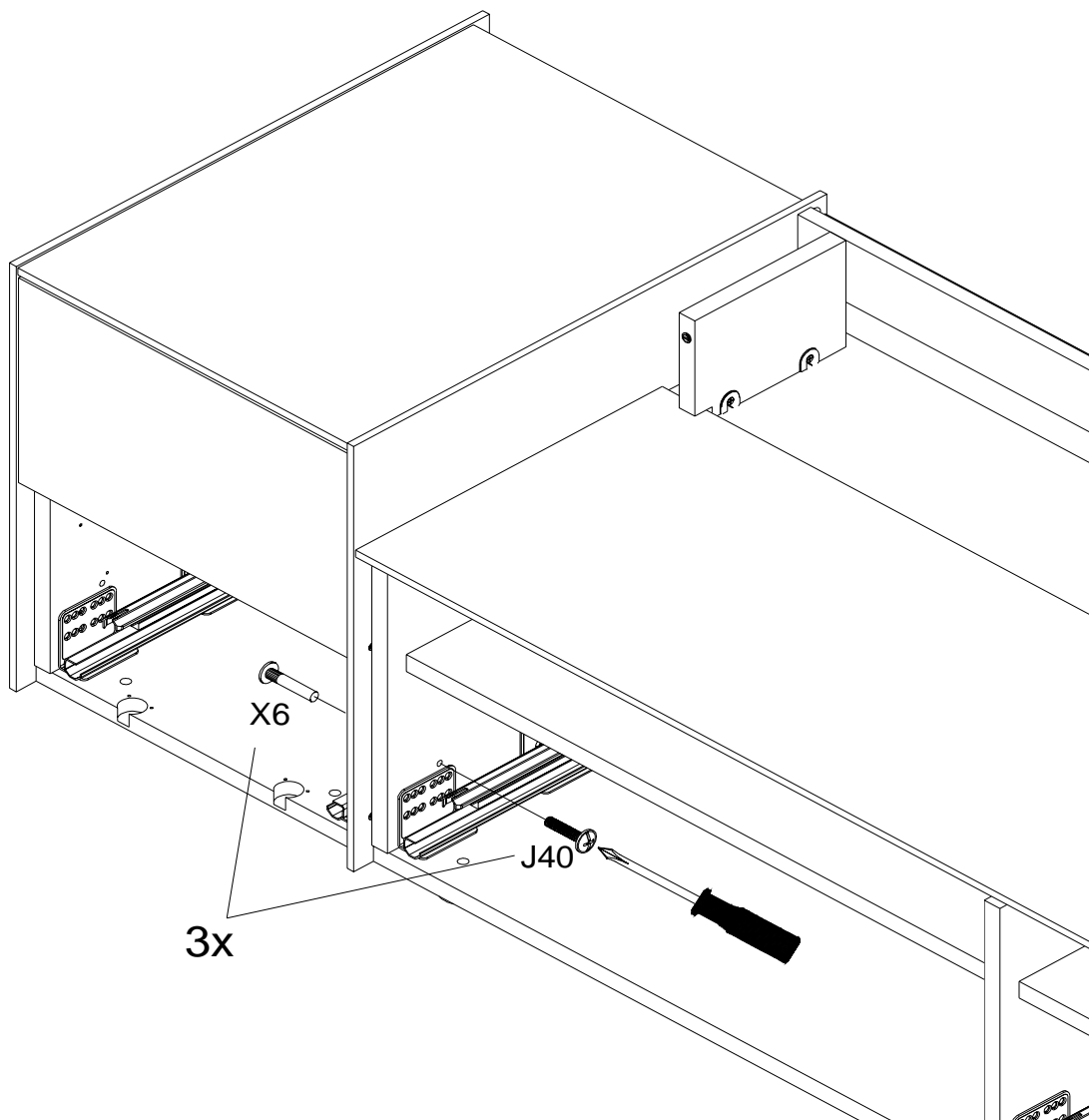
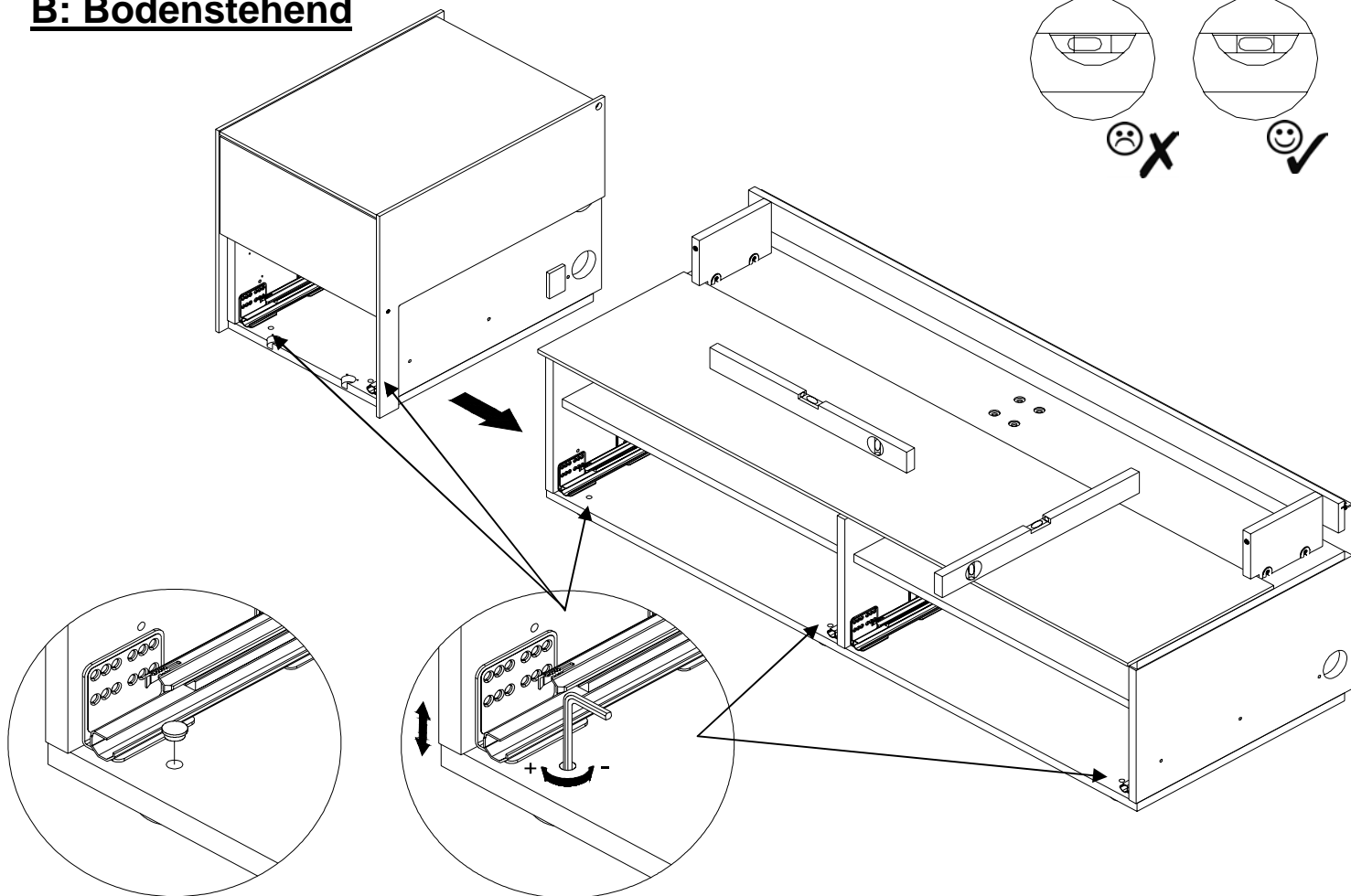
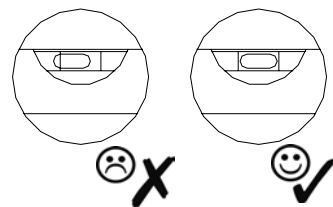

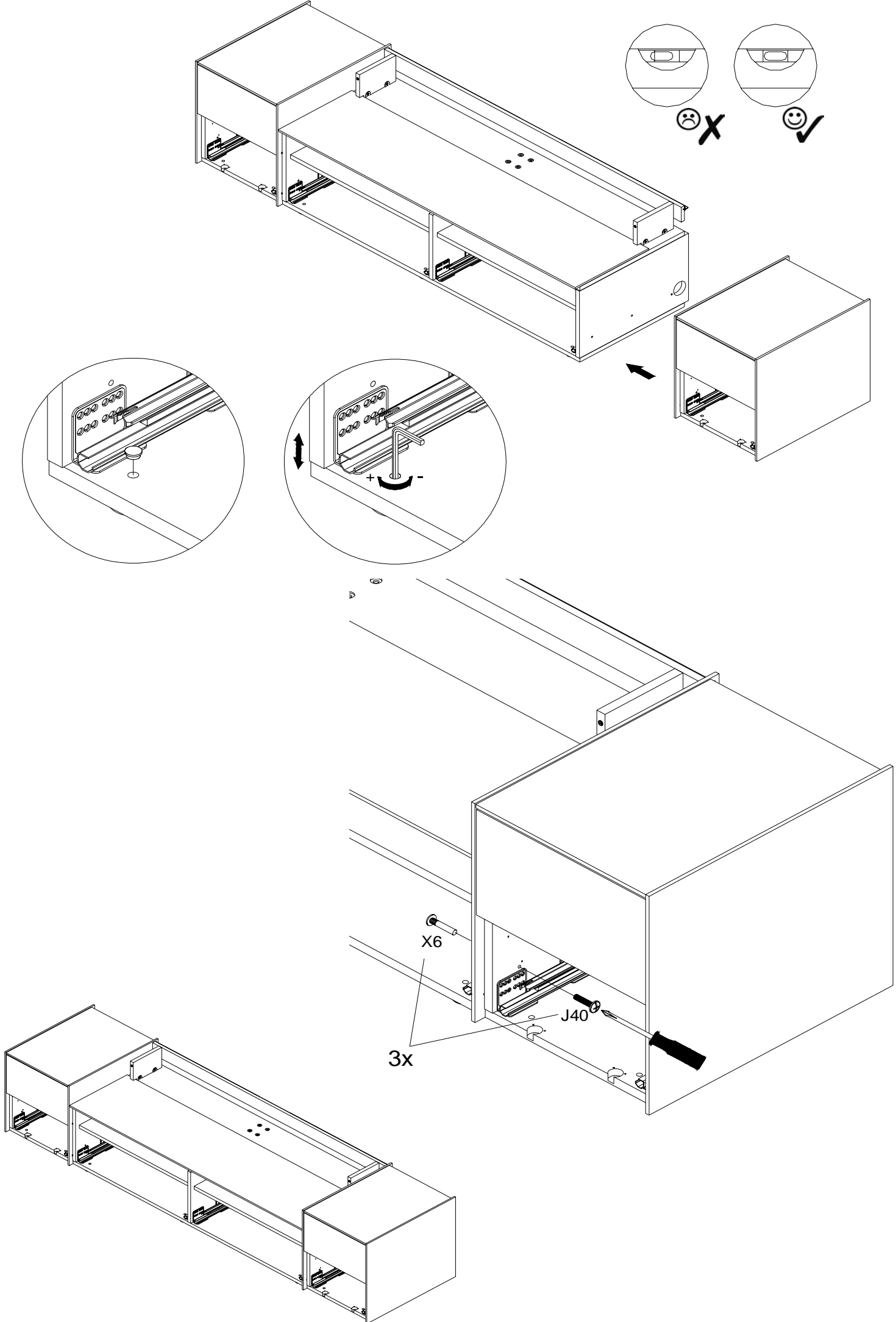



# C: Wandhängend

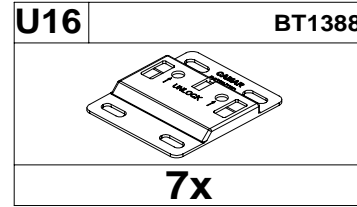
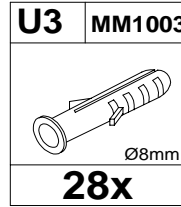
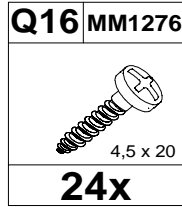
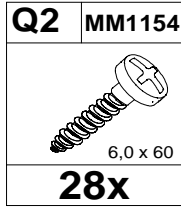
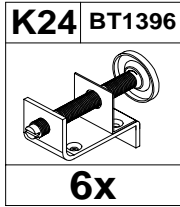

Sehr geehrte Kundin, sehr geehrter Kunde,

Das beigelegte Wandbefestigungsmaterial (Dübel und Schrauben) eignet sich nur für festes Mauerwerk (z.B. Beton- oder Ziegelwände). Für andere Wandaufbauten sind eventuell Spezialdübel und andere Schrauben notwendig. Ziehen Sie gegebenenfalls eine Fachkraft zurate. Technische Änderungen vorbehalten.

Dear customer,

the provided mounting material (dowels and screws) can only be used with solid masonry (e.g. concrete or brick walls). For other wall constructions special dowels and screws are needed. Please consider an expert in these cases.

Leaving technical changes.

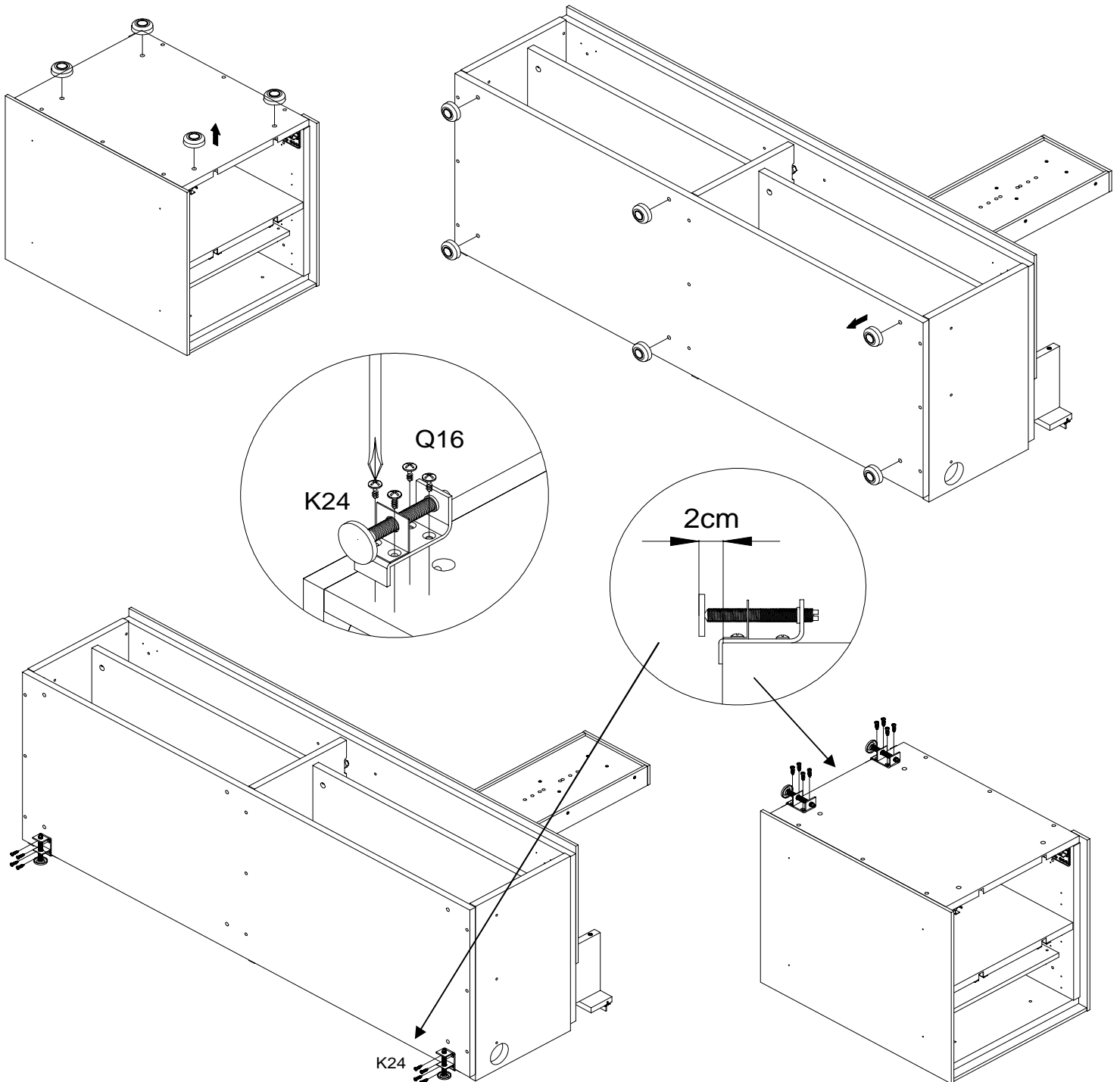

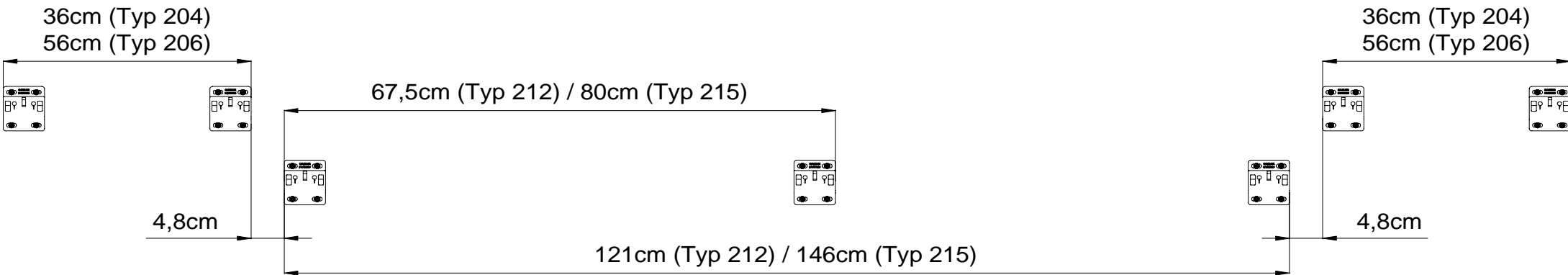
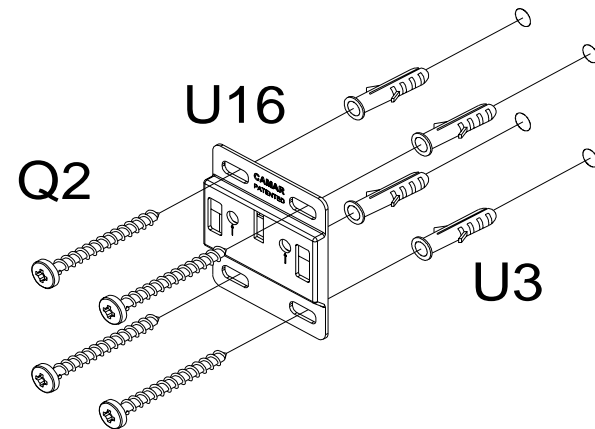
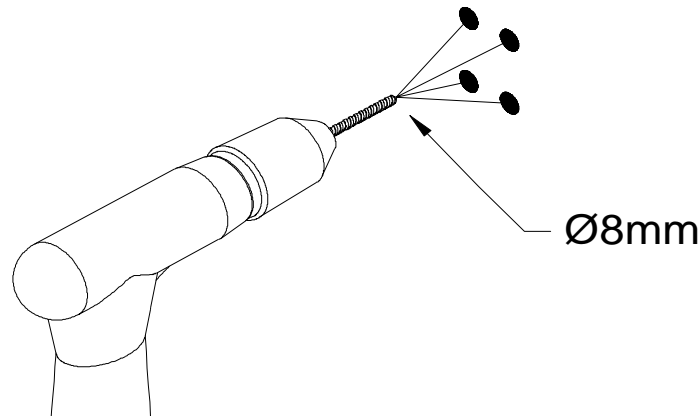
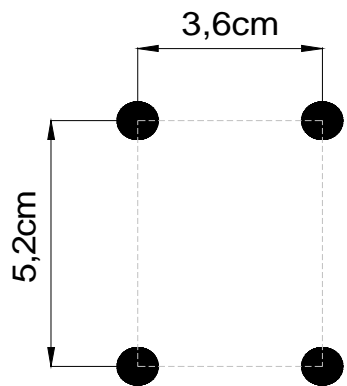
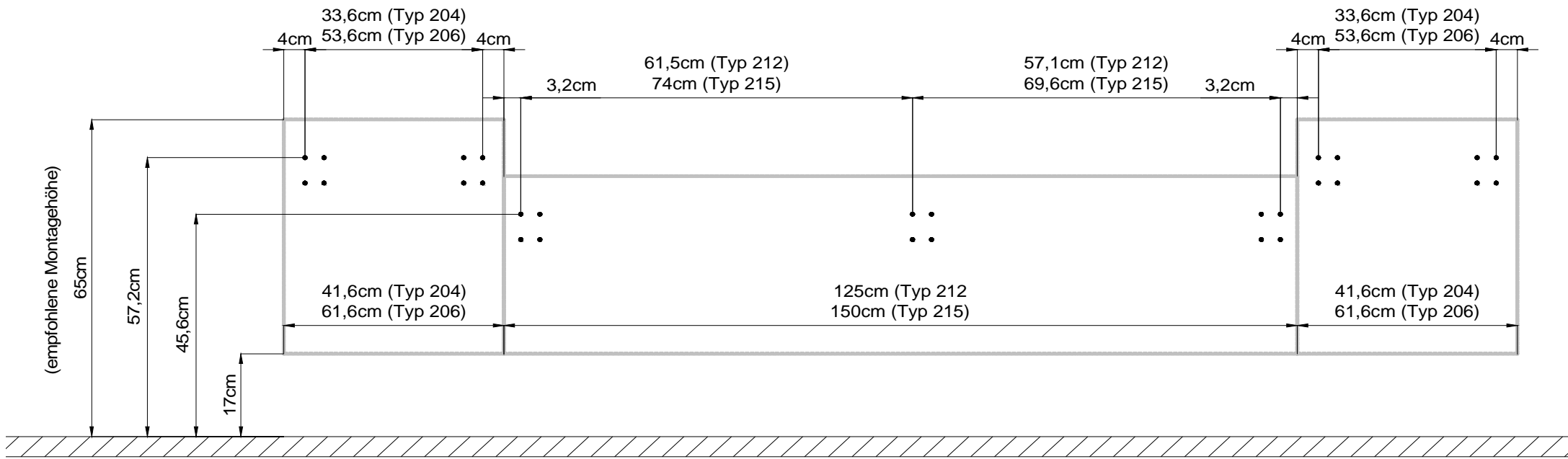

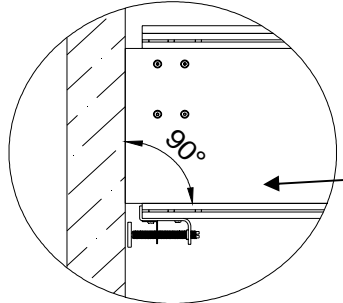
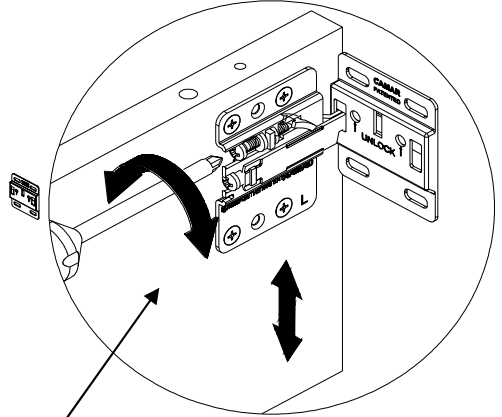
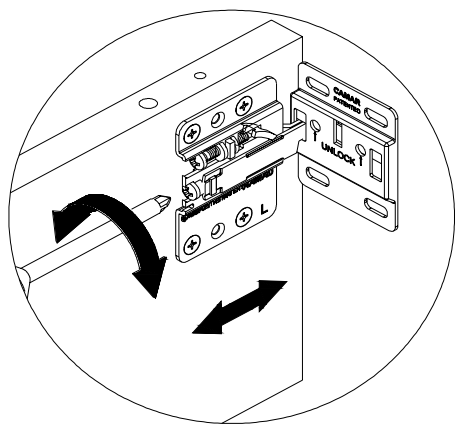
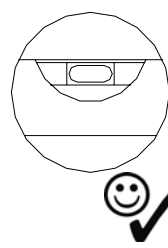
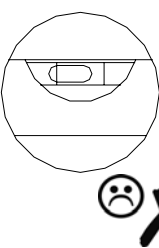
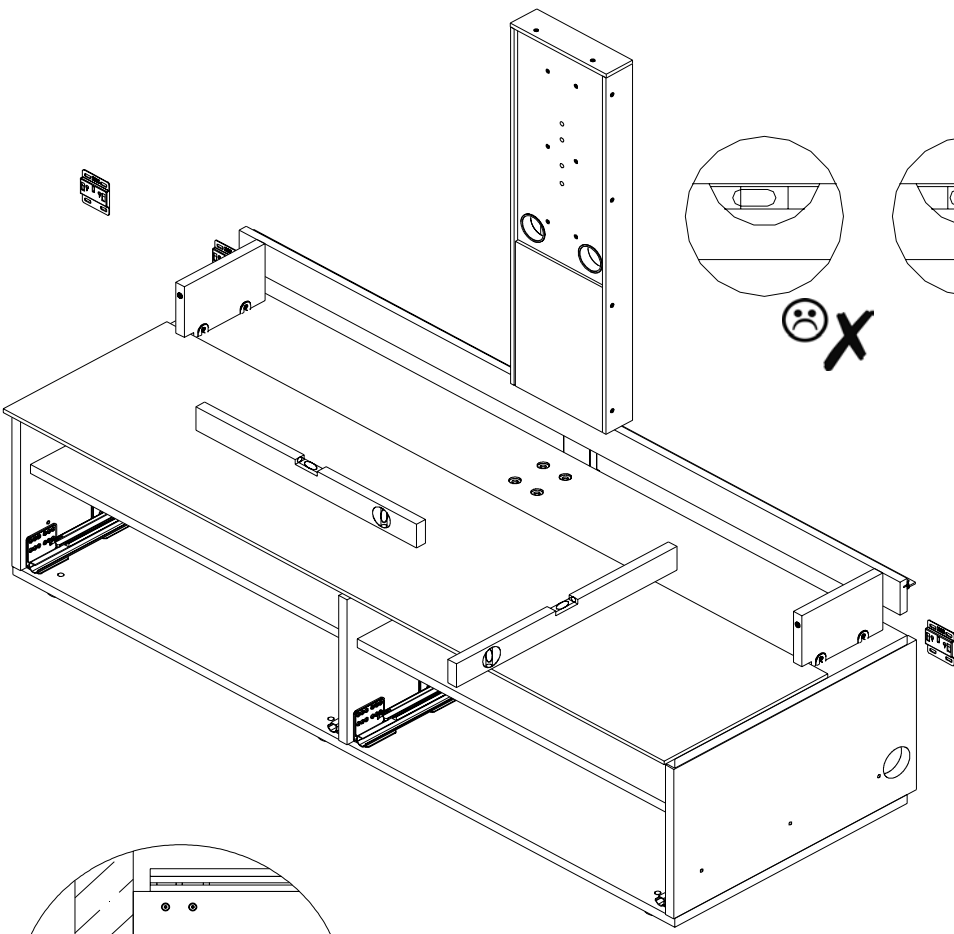
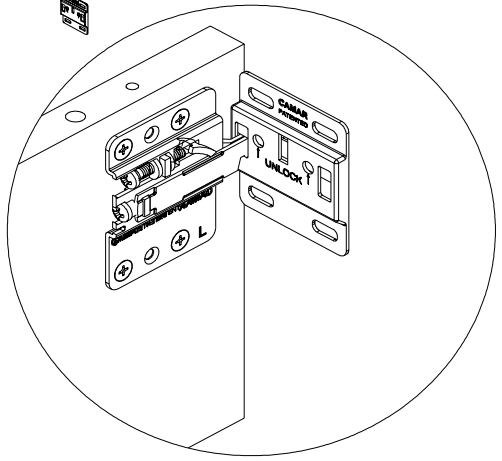
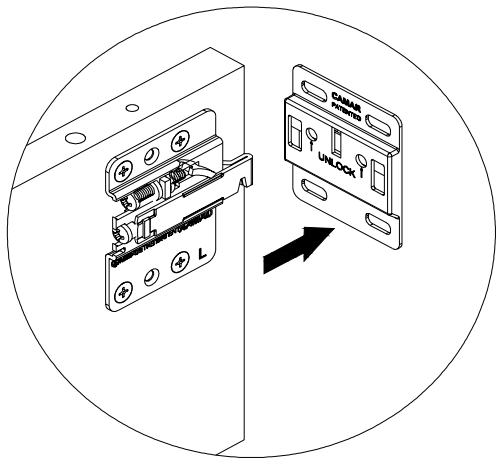
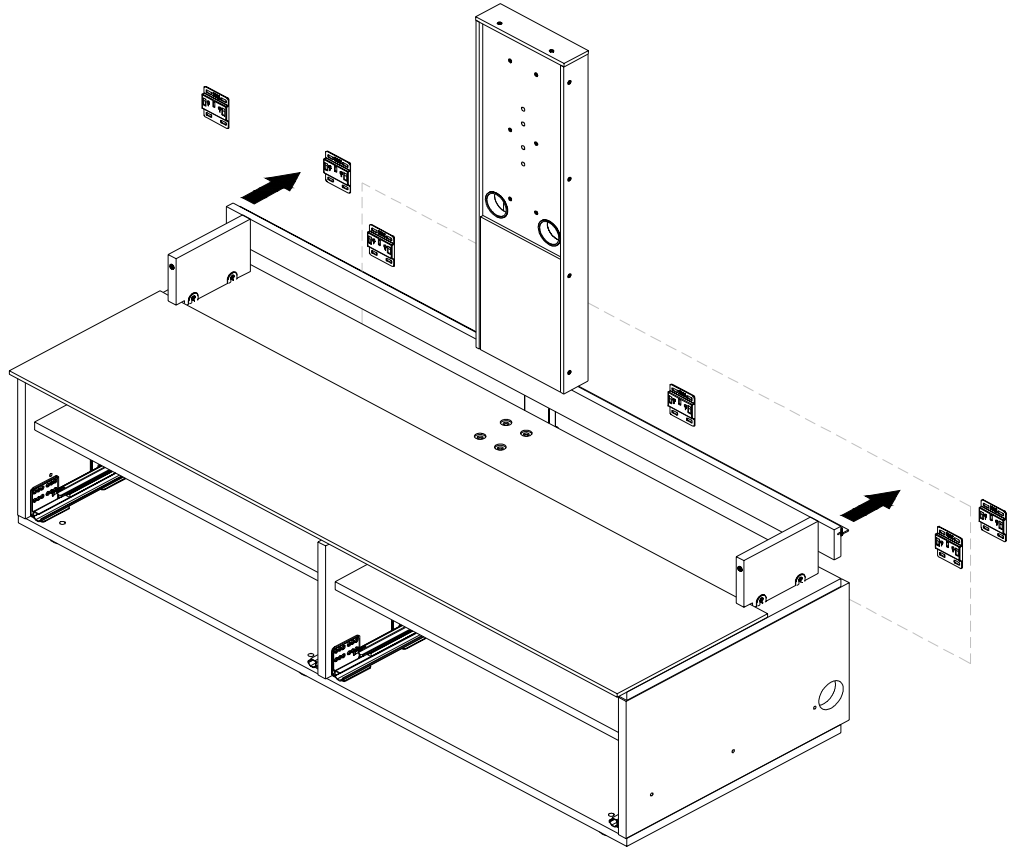

**Ausrichten des Hängeschranks durch die Stellschrauben am Aufhängebeschlag:  
Adjustment of the wall cupboard with set-screws on the fitting:**

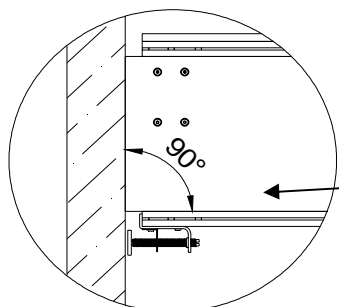
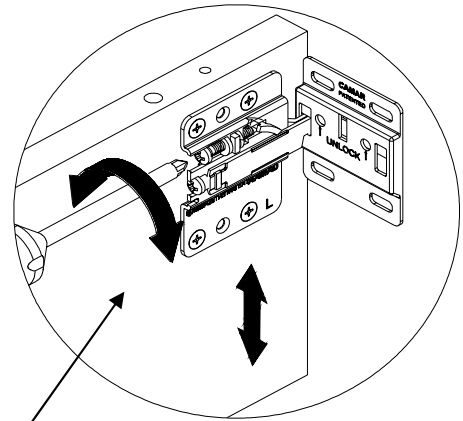
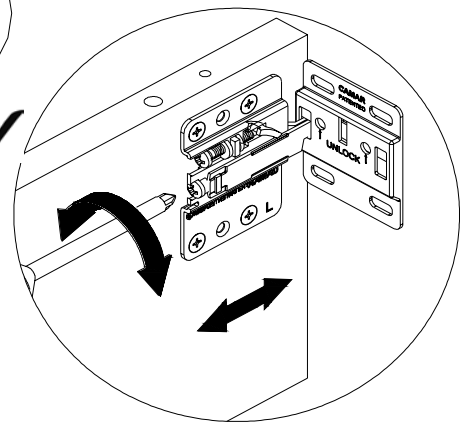
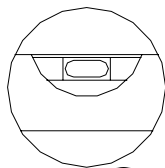
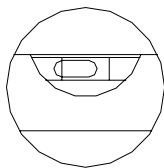
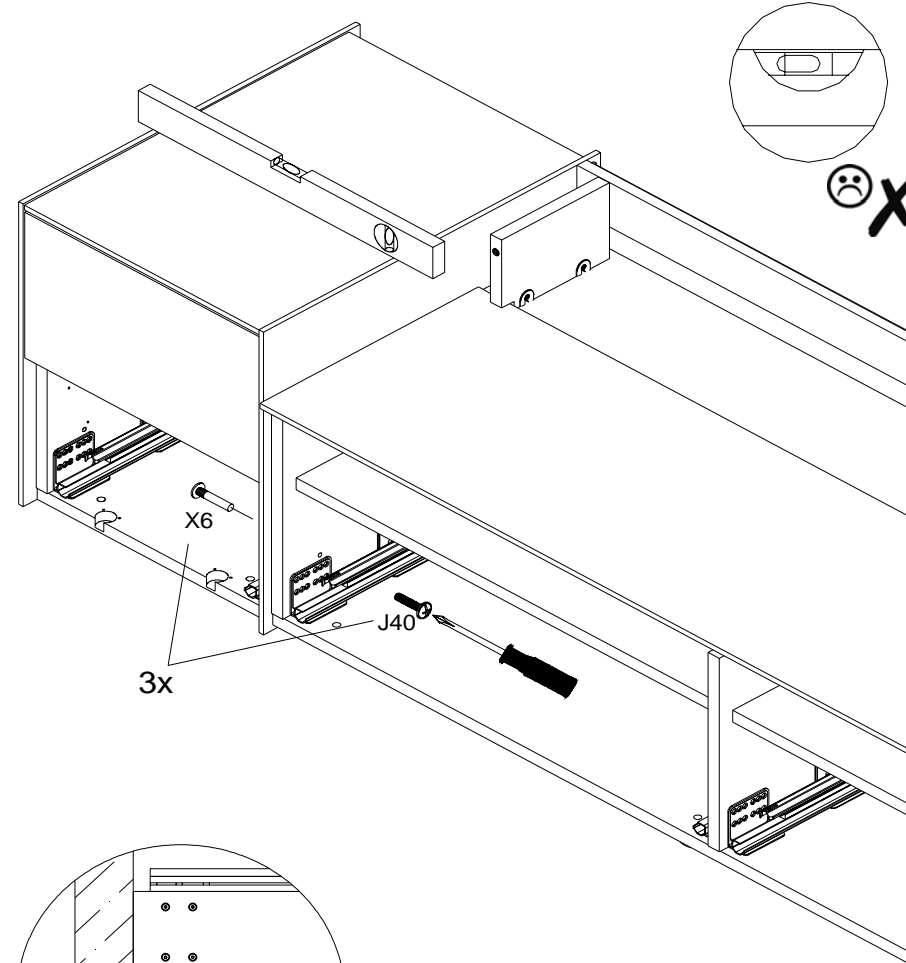
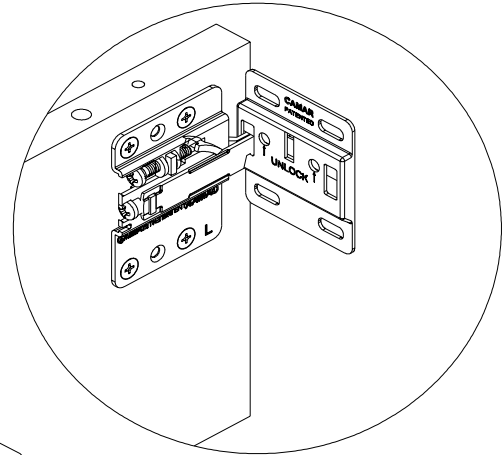
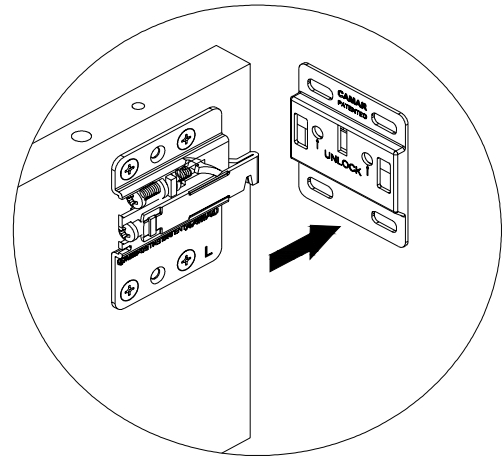
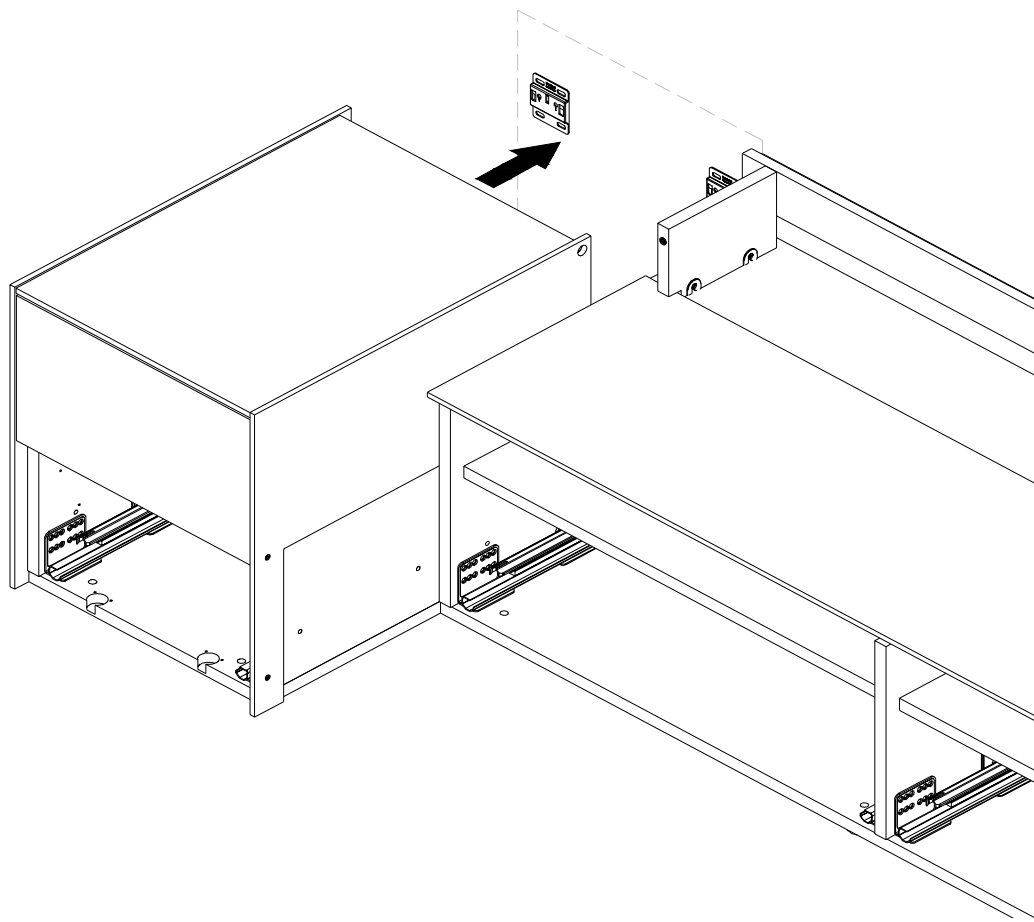

**Ausrichten des Hängeschrankes durch die Stellschrauben am Aufhängebeschlag:  
Adjustment of the wall cupboard with set-screws on the fitting:**

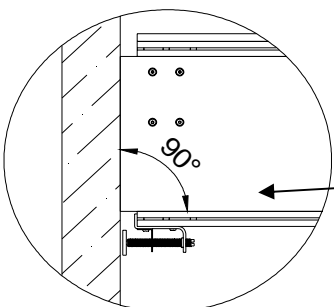
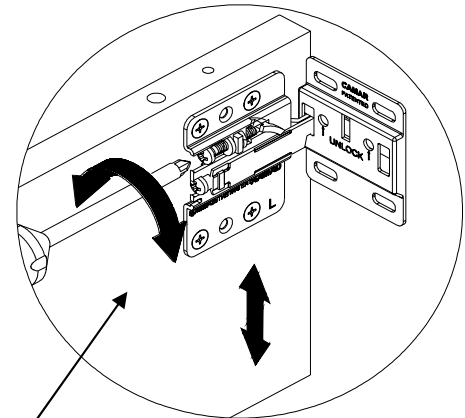
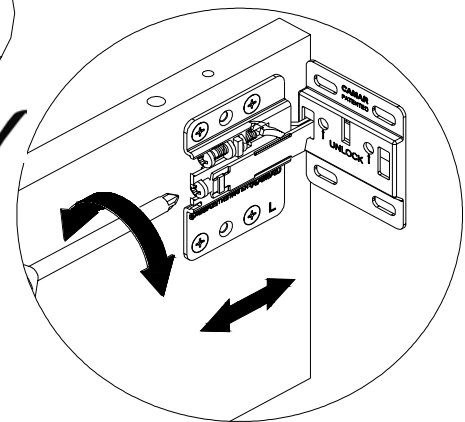
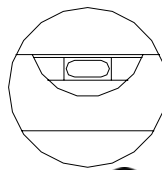
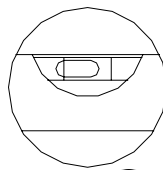
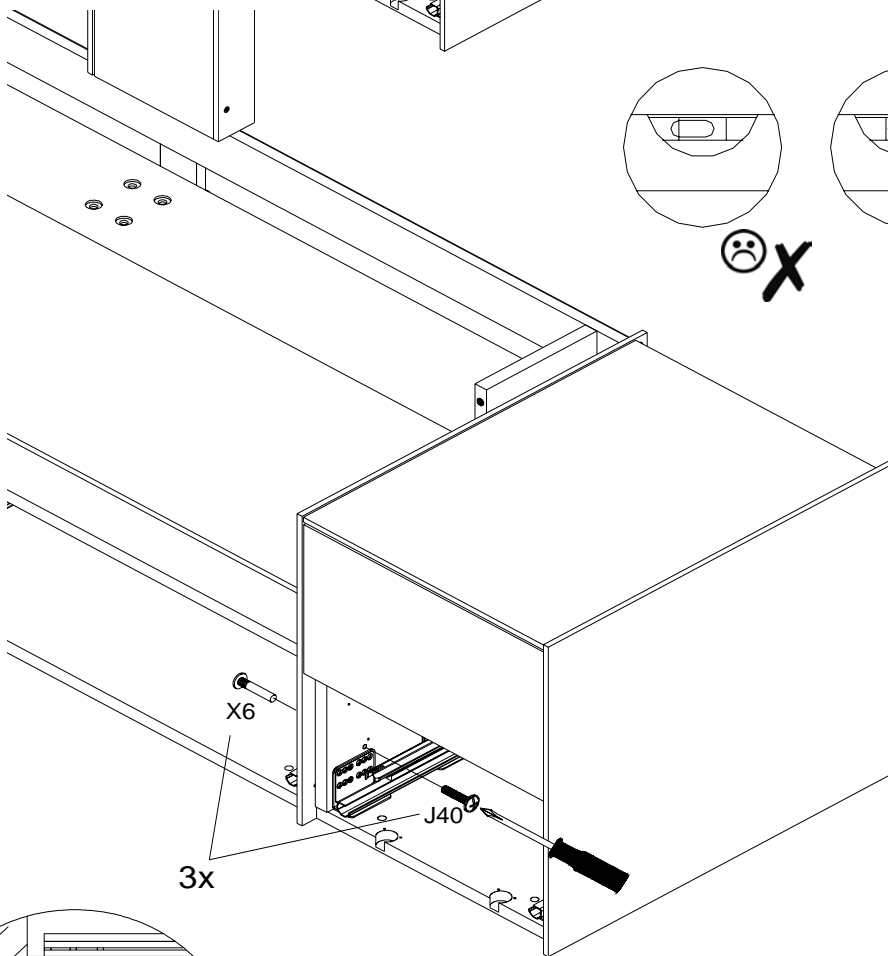
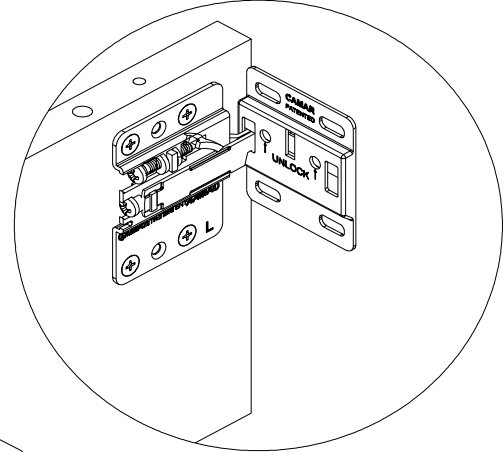
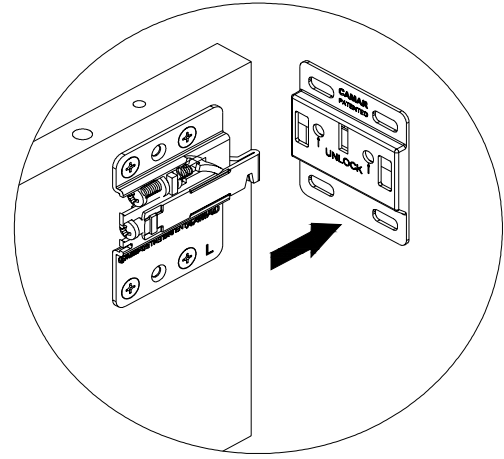
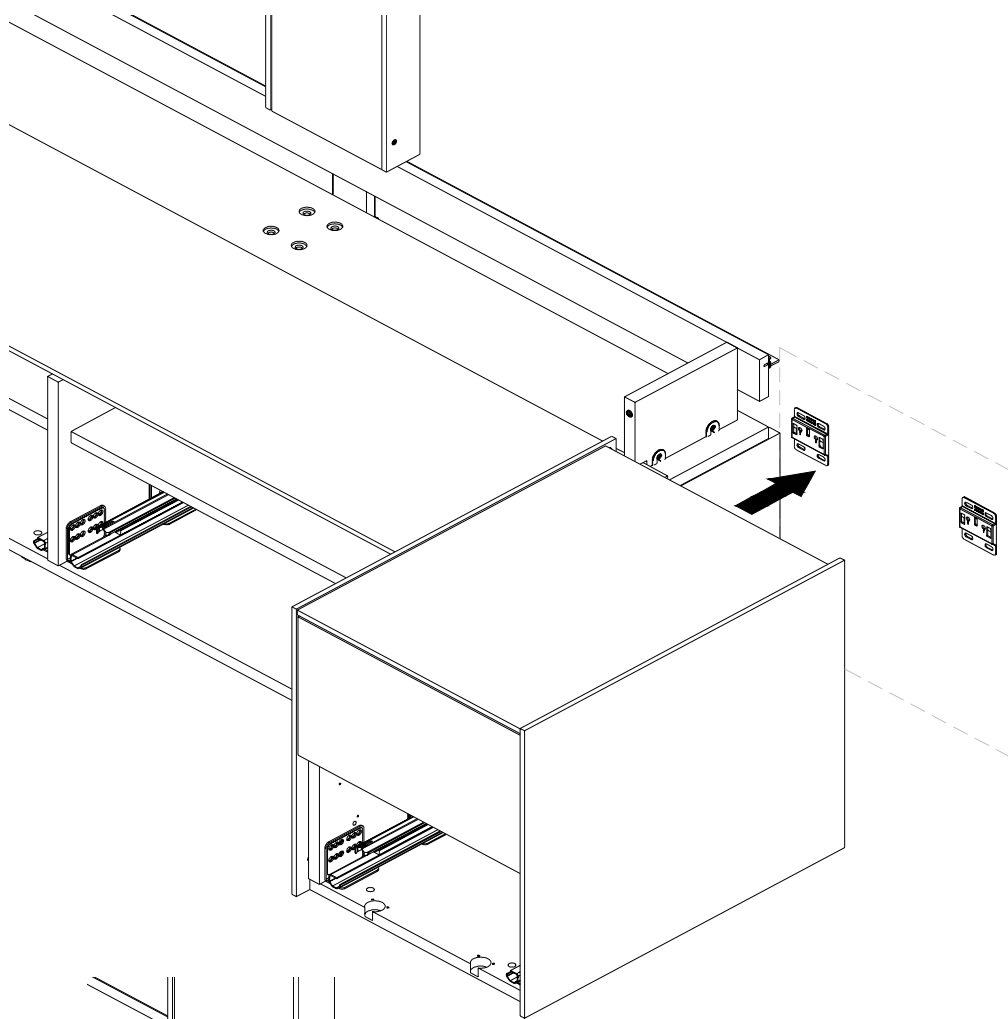

**Ausrichten des Hängeschranks durch die Stellschrauben am Aufhängebeschlag:  
Adjustment of the wall cupboard with set-screws on the fitting:**

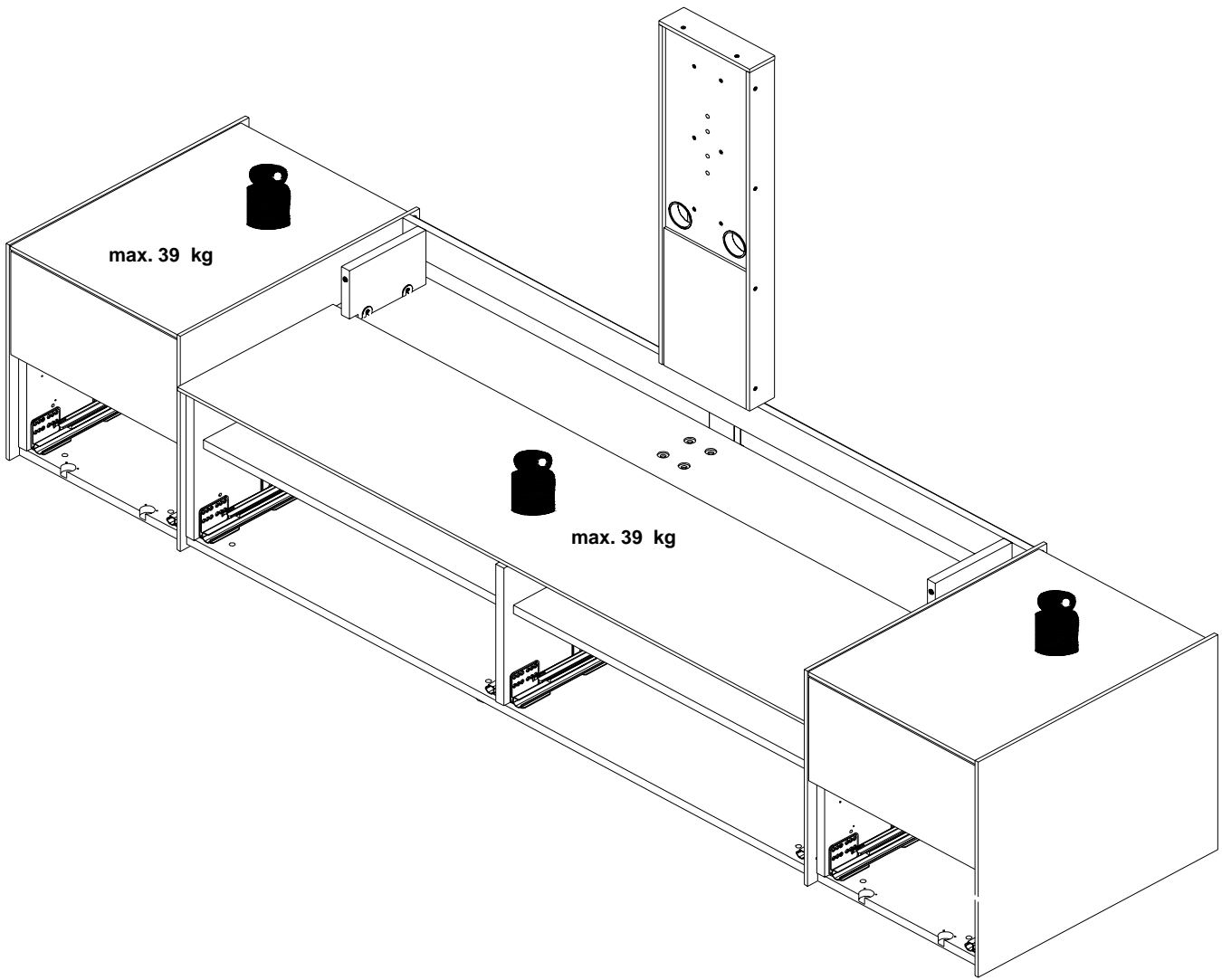

# Q-Media

## Trafo und 4-Kanal-Steuerung

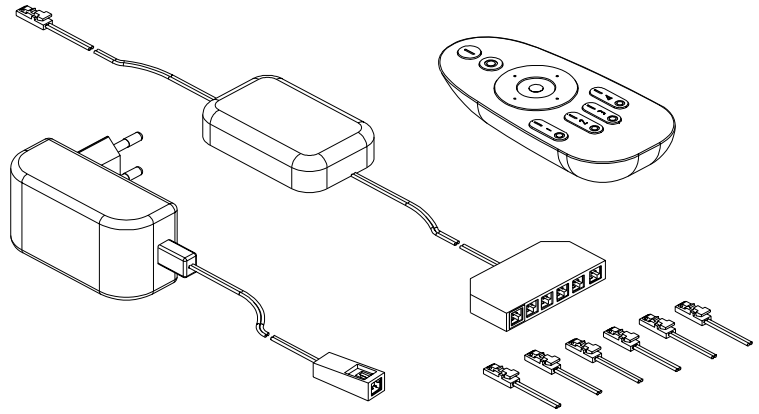

**Montage:  
Assembly:**

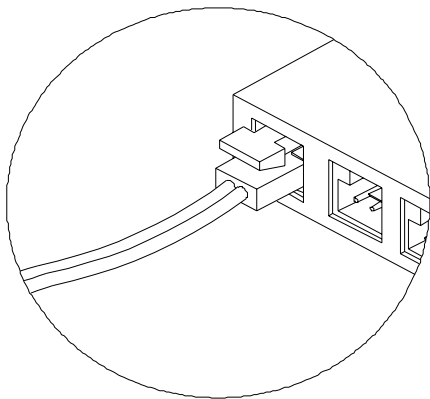
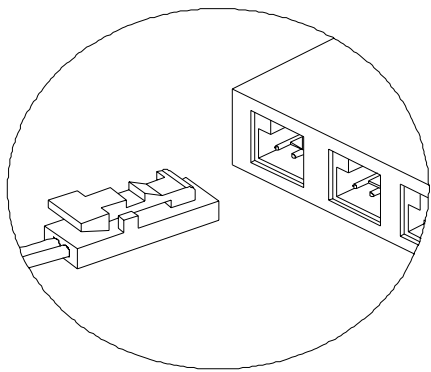

**2. kurzer Tastendruck  
I / O => on / off !**

**1. Schutzfolie der  
Batterie entfernen  
=> Inbetriebnahme !**

**3. langer Tastendruck  
Ring oben / unten  
=> dimmen !**

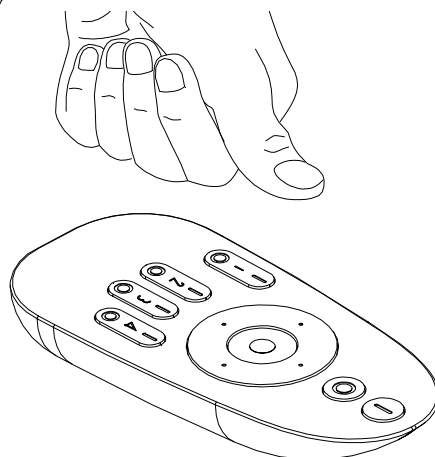

# 1-Kanal Funkfernbedienung

Herzlichen Glückwunsch! Sie haben sich für ein qualitativ hochwertiges, energiesparendes Beleuchtungssystem entschieden. Bei richtiger Handhabung werden Sie sehr lange Freude daran haben. Diese Anleitung bitte gut aufbewahren!



## !ACHTUNG!

Um die reibungslose Funktionsfähigkeit sicher zu stellen, wickeln Sie bitte vor Montage und Inbetriebnahme beide Zuleitungskabel vollständig ab.

## PROGRAMMIEREN

Mit diesem Steuerungssystem haben sie die Möglichkeit, Ihre Beleuchtung in bis zu 4 Kanälen zu gruppieren und zu schalten.

Um die Steuerung zu programmieren, trennen Sie bitte die Beleuchtung komplett vom Stromnetz. Warten Sie ein paar Sekunden, bis alle Geräte frei von Reststrom sind, dann schließen Sie die Beleuchtung wieder an das Stromnetz an.

Innerhalb von 3 Sekunden nach Anschließen der Beleuchtung an das Stromnetz, drücken Sie die gewünschte Kanaltaste ein Mal. Die angeschlossene Leuchte blinkt mehrmals schnell hintereinander und ist jetzt programmiert und einsatzbereit.

Auf diese Weise können Sie jede weitere Leuchte einem der 4 Kanäle zuordnen.

## TECHNISCHE ANGABEN

Typ Fernbedienung:	Vario
Spannung:	12 VDC
Schaltleistung:	60W
Primärkabel:	2m
Sekundärkabel:	2m

## EIN- / AUS

Drücken Sie die ON-Taste ein Mal, um die Beleuchtung einzuschalten. Um die Beleuchtung auszuschalten, drücken Sie die OFF-Taste ein Mal.

**ACHTUNG:** Haben Sie mehrere Beleuchtungssysteme auf eine Fernbedienung programmiert, schalten Sie einzelne Beleuchtungsgruppen auch mit den Gruppentasten.

## DIMMEN

Mittels des Bedienungsrad lässt sich Ihre Beleuchtung bis auf 20% der Leuchtkraft runterdimmen.

Drücken Sie den unteren oder linken Teil des Bedienungsrad, dimmen Sie die Beleuchtung runter. Zum Hochdimmen der Beleuchtung drücken Sie den oberen oder rechten Teil des Bedienungsrad.

Um sofort die maximale Helligkeit zu erreichen, drücken Sie die ON-Taste für 2 Sekunden. Drücken Sie die OFF-Taste für 2 Sekunden, wird sofort die niedrigste Dimmstufe eingestellt. Diese eignet sich ideal als Nachtlicht.



Stand: 30.11.2015



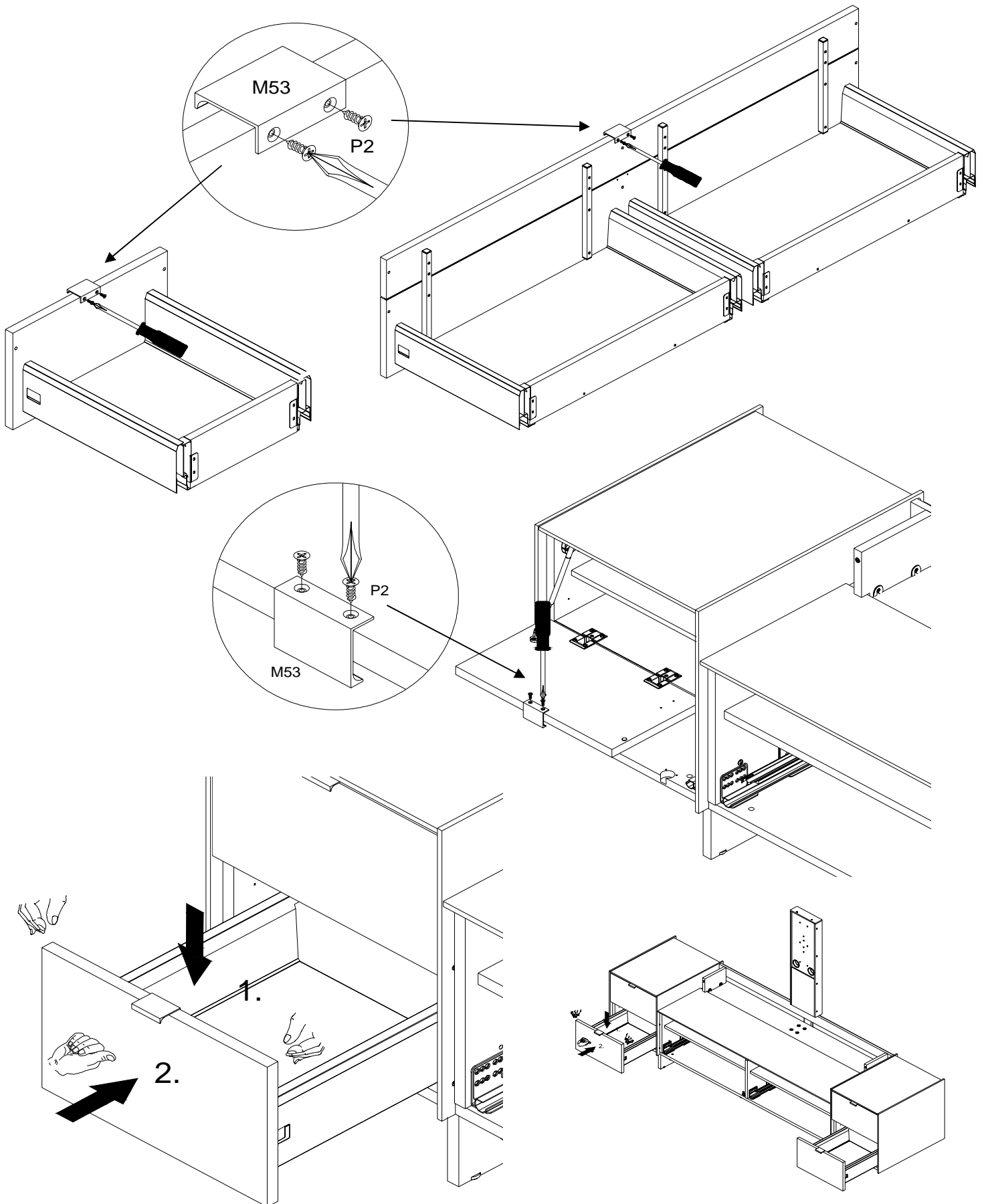

**Montagehinweis:**

Die Auszüge in den Korpus hinein schieben, wie bei geschlossener Stellung.  
 Dann den Stahl-Schubkasten auf die Auszüge legen und fest in den Schrank schieben,  
 bis das System einrastet.

**Assembly note:**

Put the Sliding statements into the cupboard as in the case of closed position.  
 Putting then the steel drawer on the statements and sliding into the cupboard tightly  
 until the system clicks in.

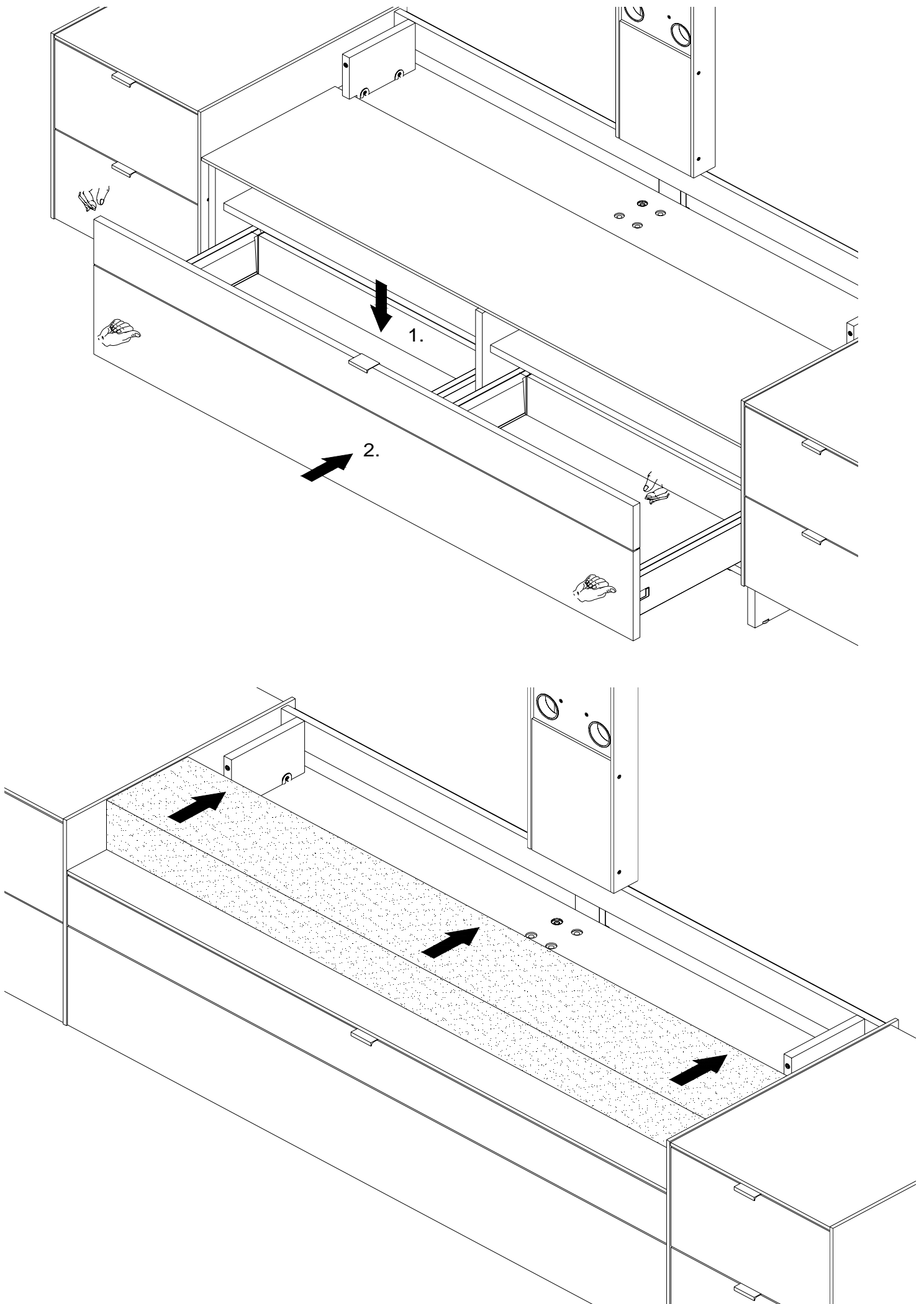

## Verschieben des Oberbodens:

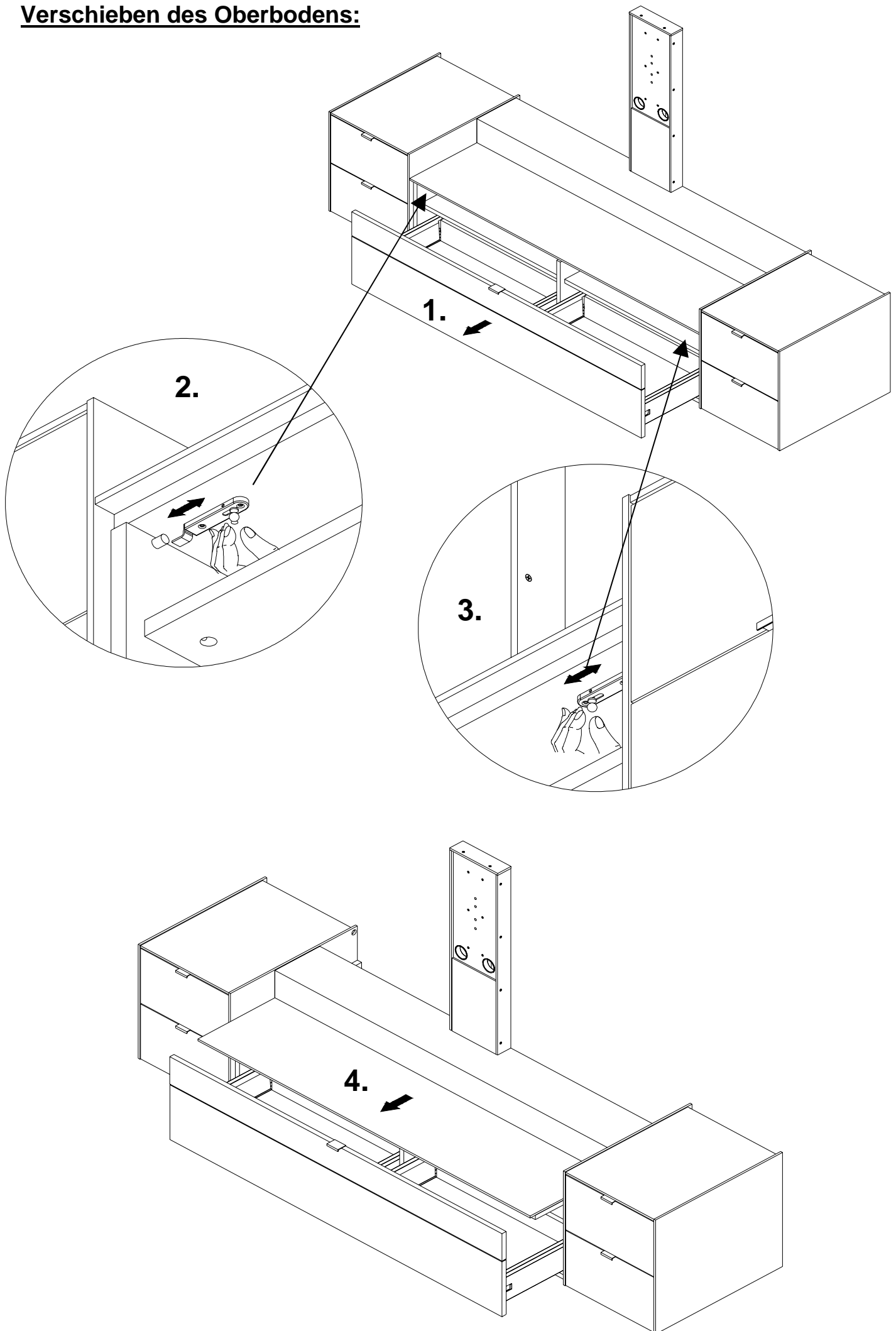

**Einstellung der Schubkästen:  
Adjustment of the drawers:**



**Verstellung der Front:  
Adjustment of the Front:**

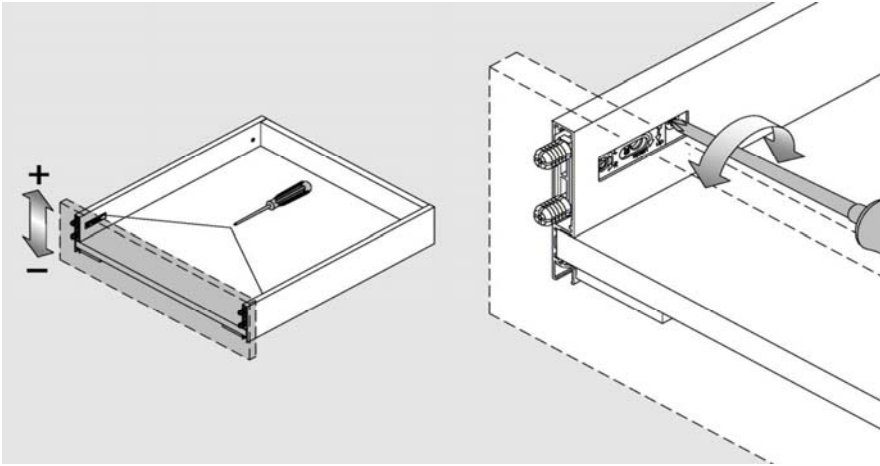

**Height**

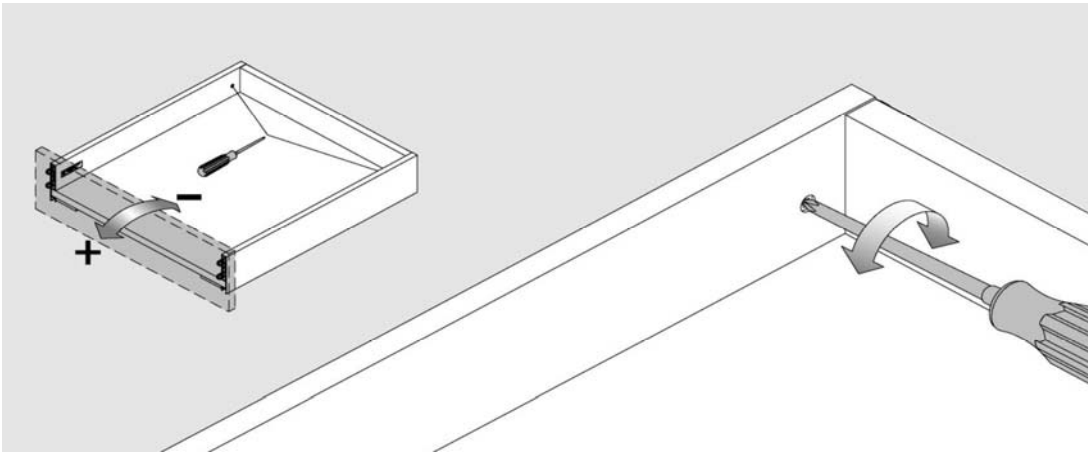

**Tipe**

**Auf beiden Seiten vornehmen/Adjust both sides/  
À faire des deux côtés/Eseguire su entrambi i lati/  
Realizar a ambos lados/Görs på båda sidorna**

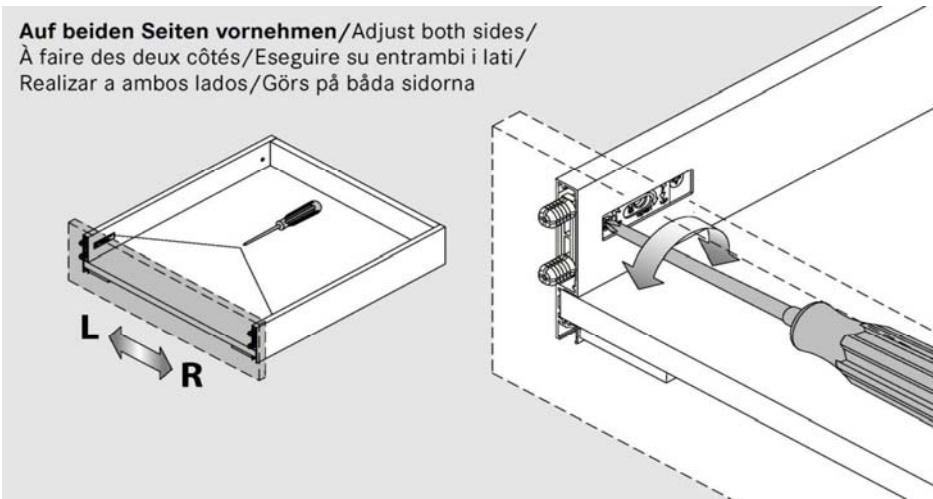

**Horizonta**

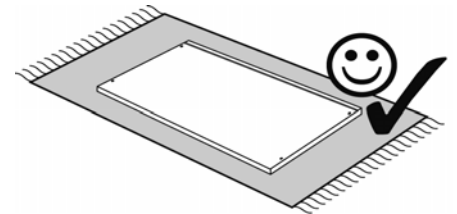

**Demontage der Front  
Dismounting of the Front**

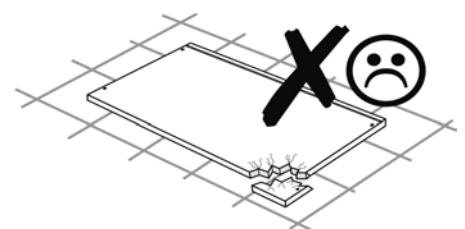
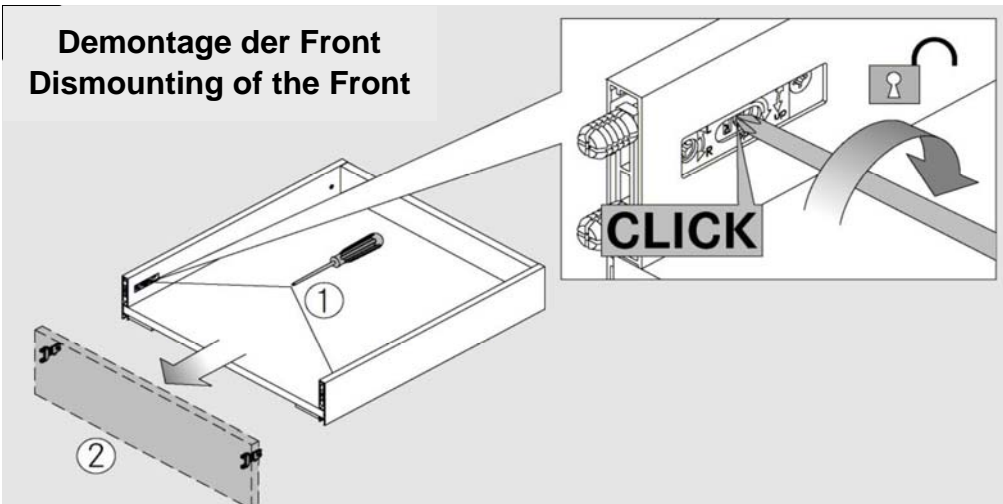

**Demontage der Klappen:**

**Dismounting the flaps:**

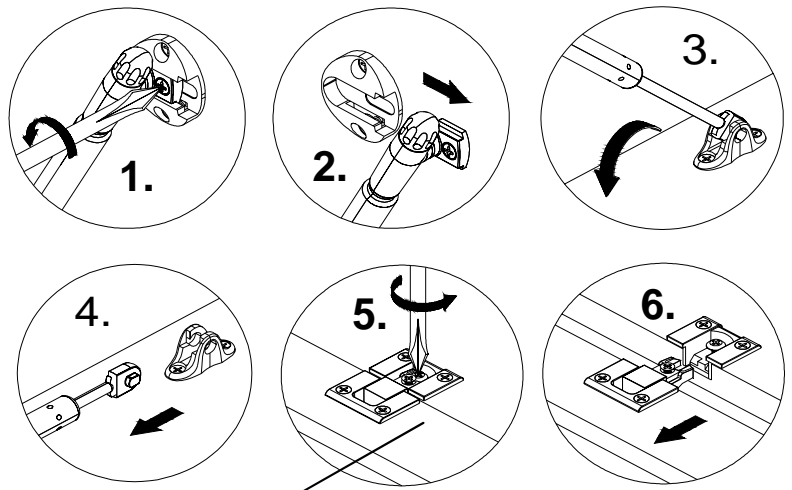
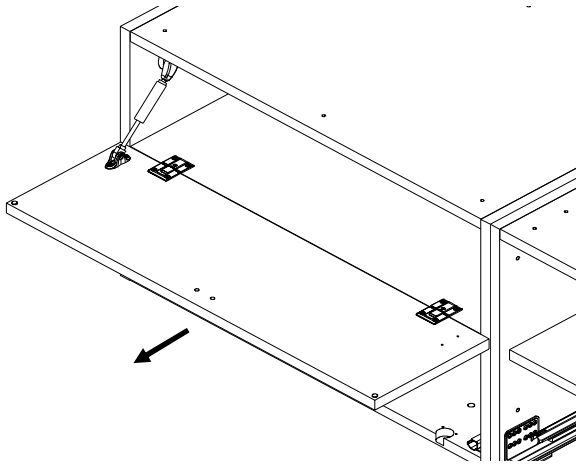

**Montage der Klappen:**

**Assembling the flaps:**

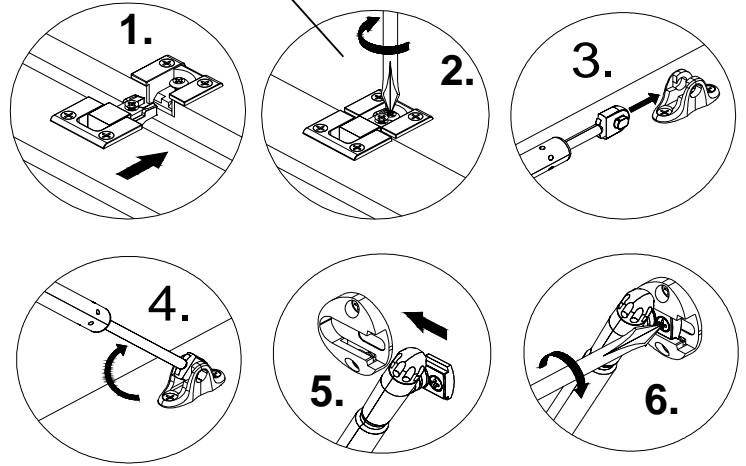
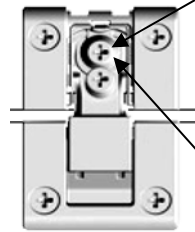
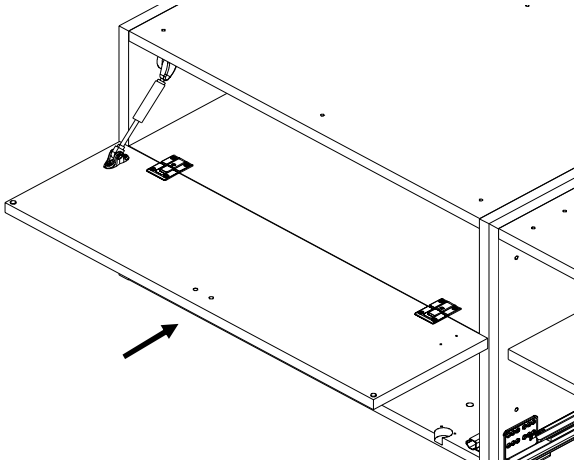

**Tiefenverstellung:  
Depth adjustment:**

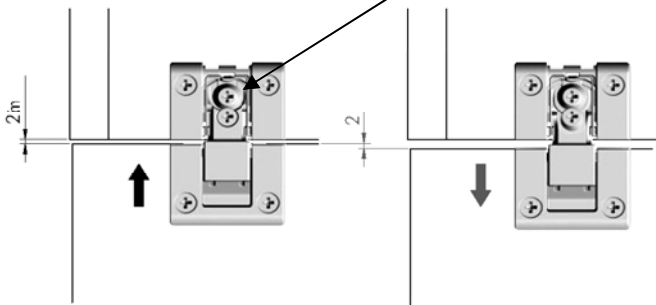

**Seitenverstellung:  
Horizontal adjustment:**

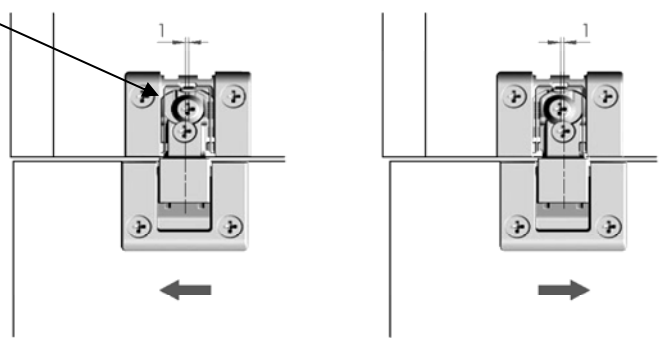

**Höheneinstellung:  
Height adjustment:**

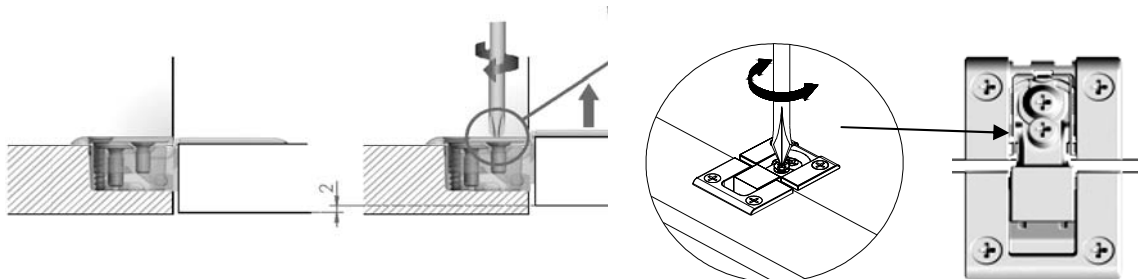

# Q-Media

Anbauelement 2R 160cm  
mit Stoffklappe und  
Schubkästen

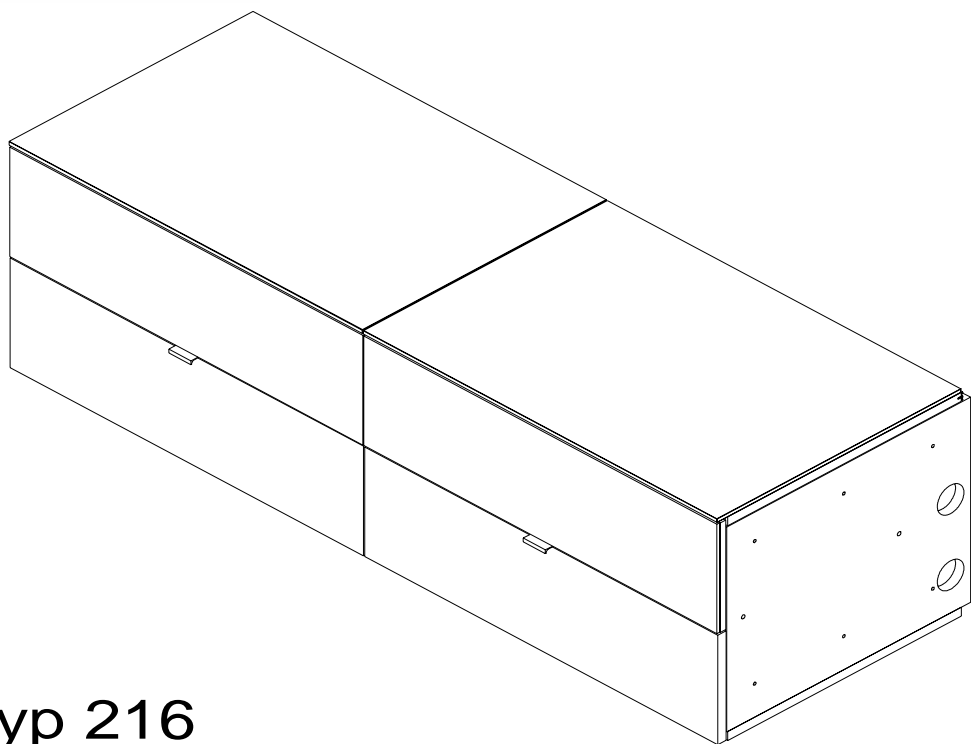

## Beschlagteile Typ 216

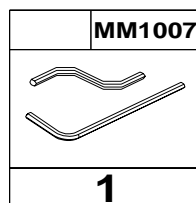
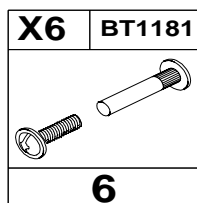
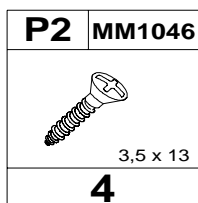
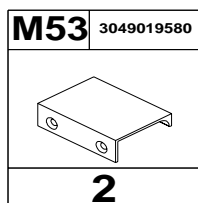

Beschlag / Fitting / Montaža / Felszerelés / Montaj / Vybavení / Vybavenie /  
Ugradnja / Фитинги / Uydurma / Adattamento:

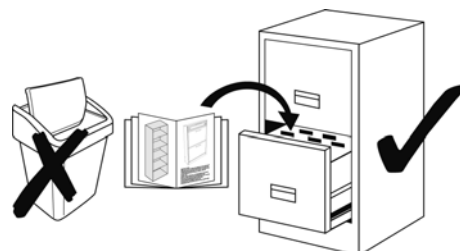
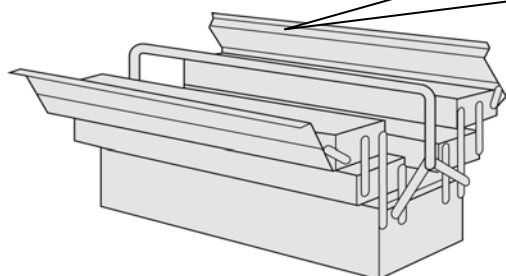
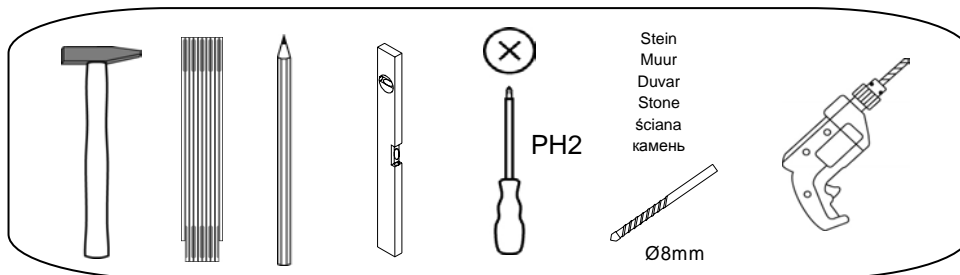
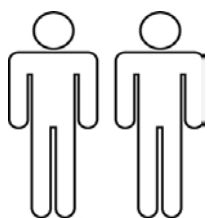

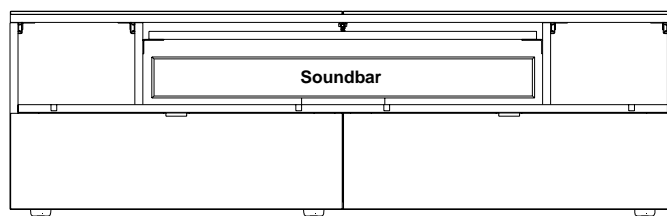

Wahlweise / optional

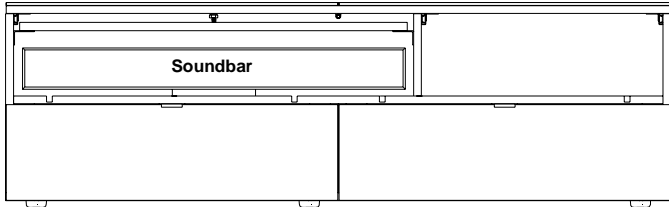

links / left

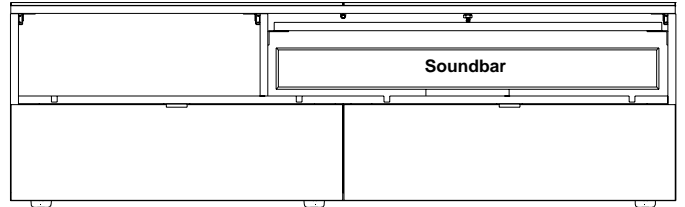

rechts / right

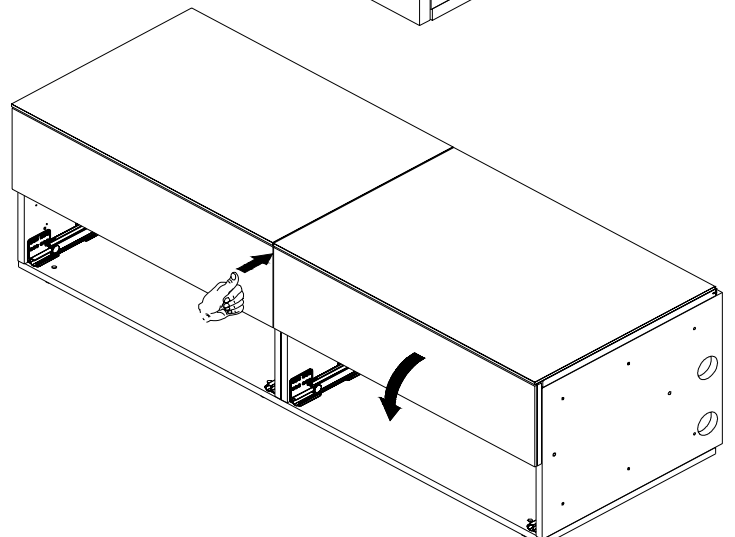
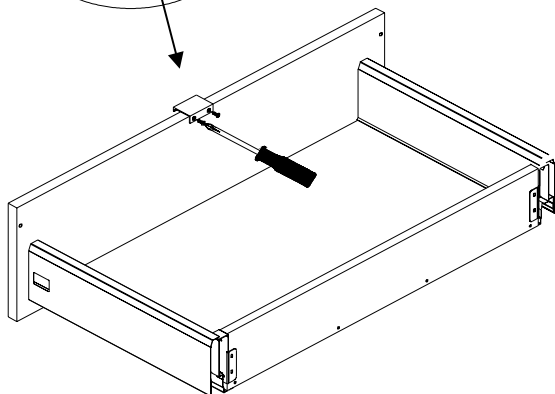
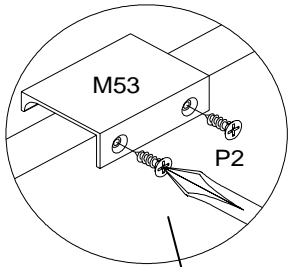
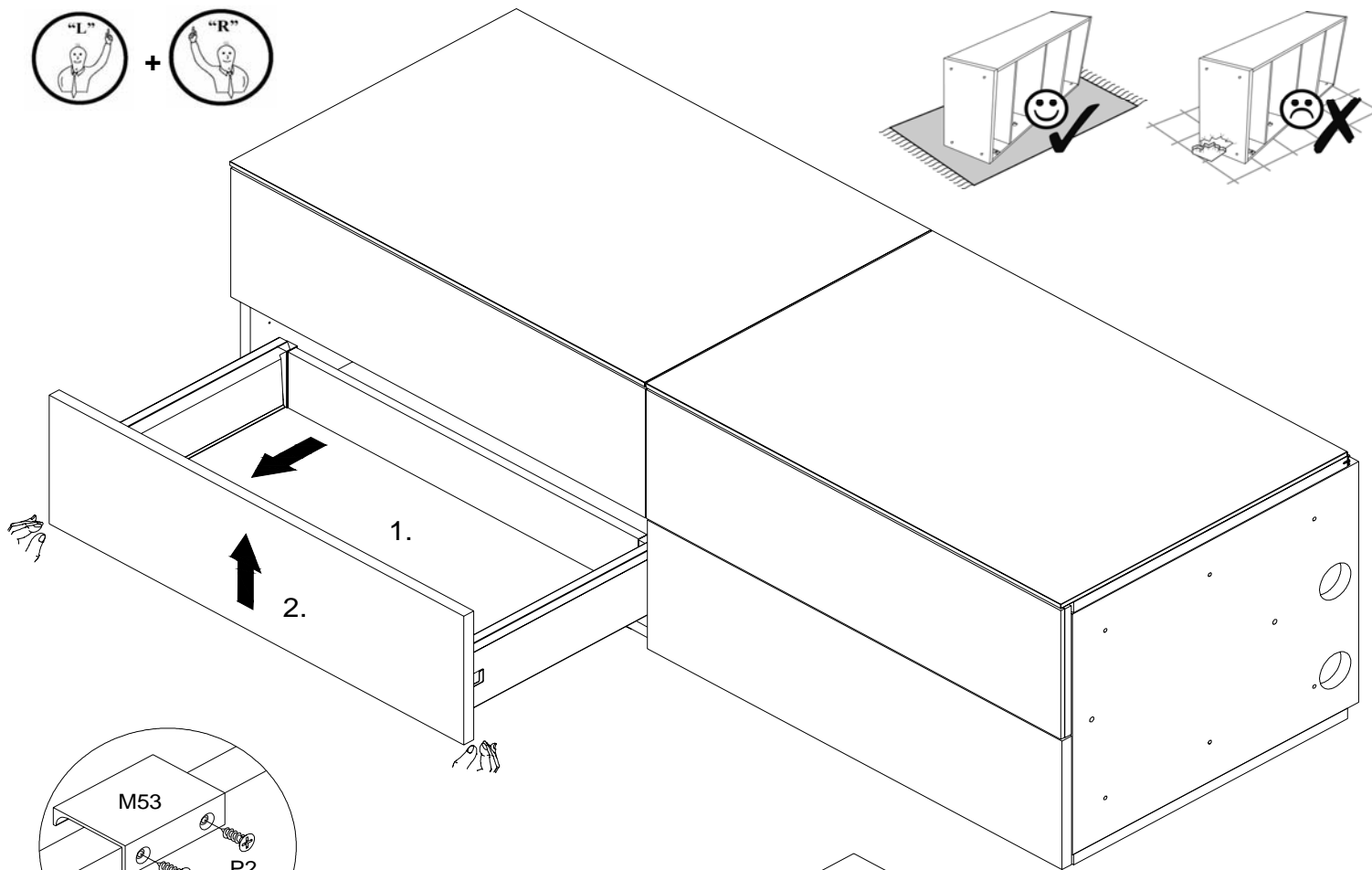
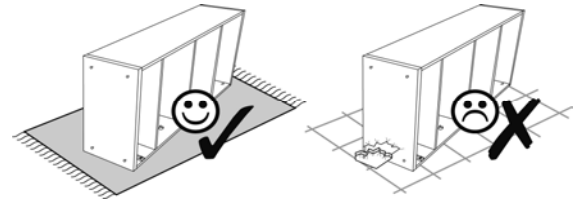
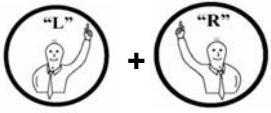

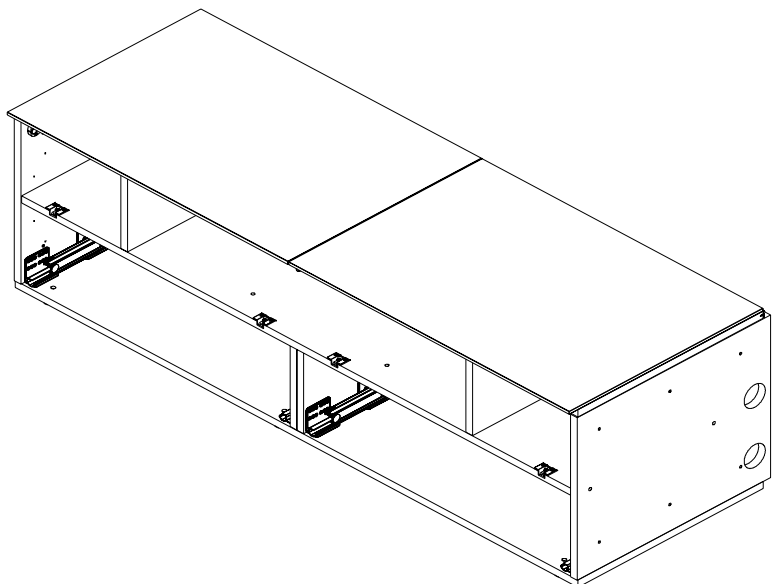
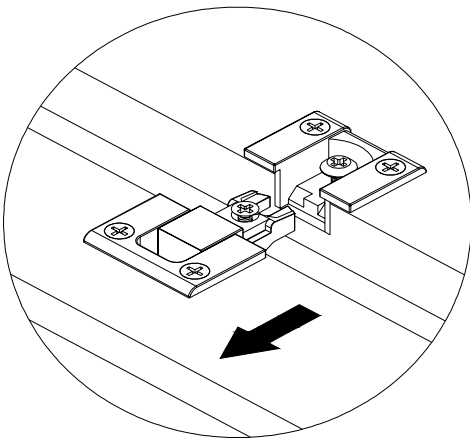
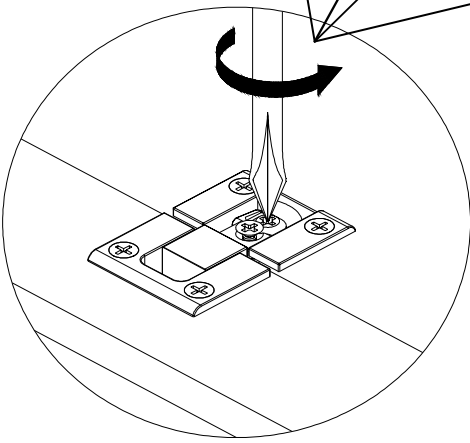
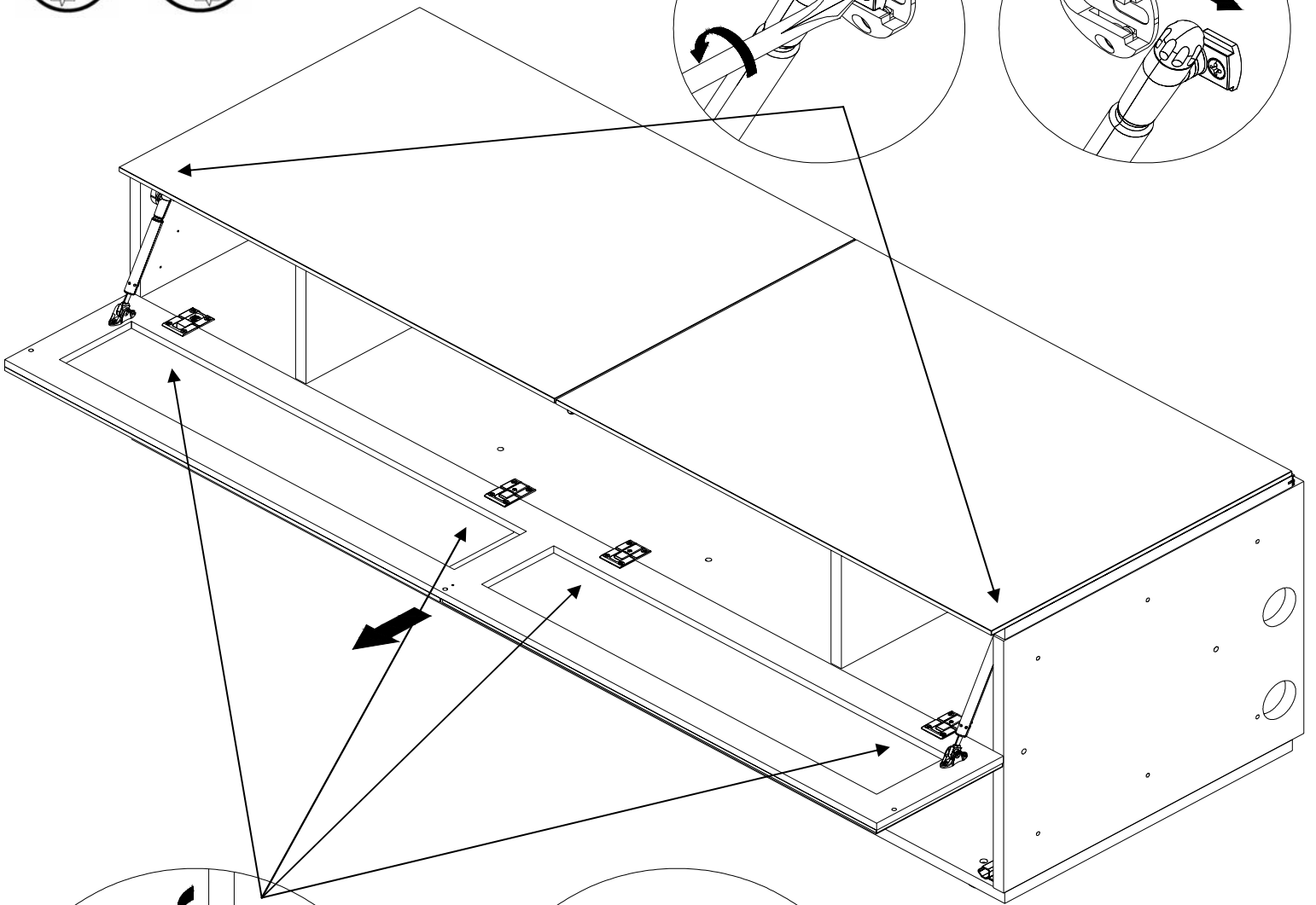
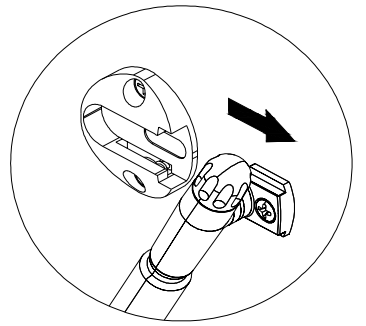
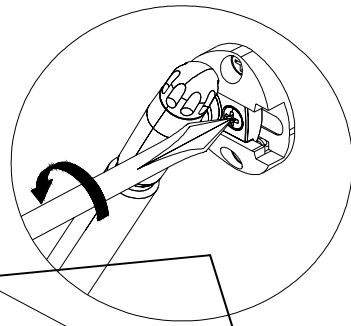
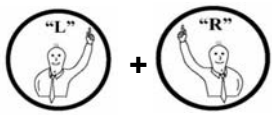



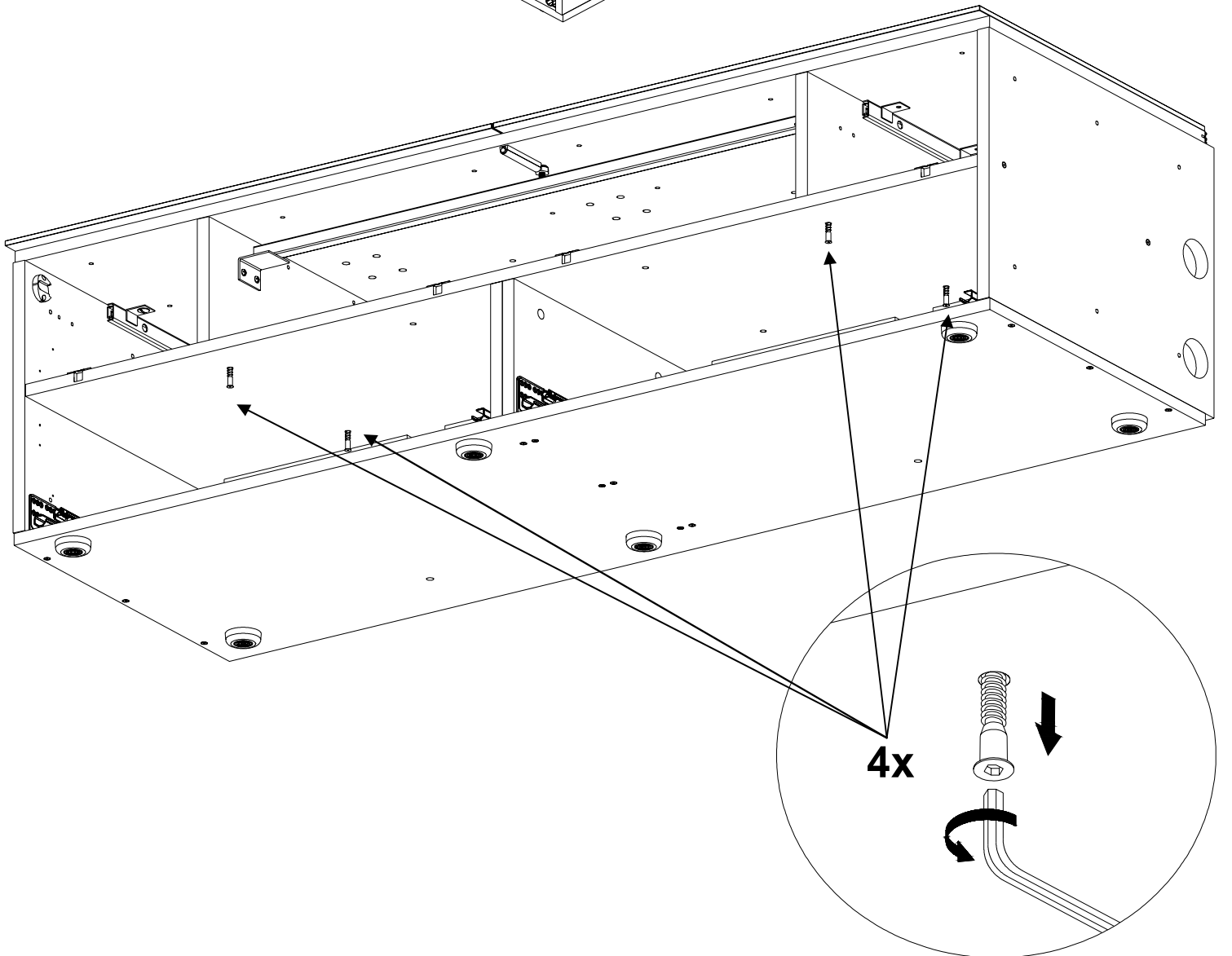
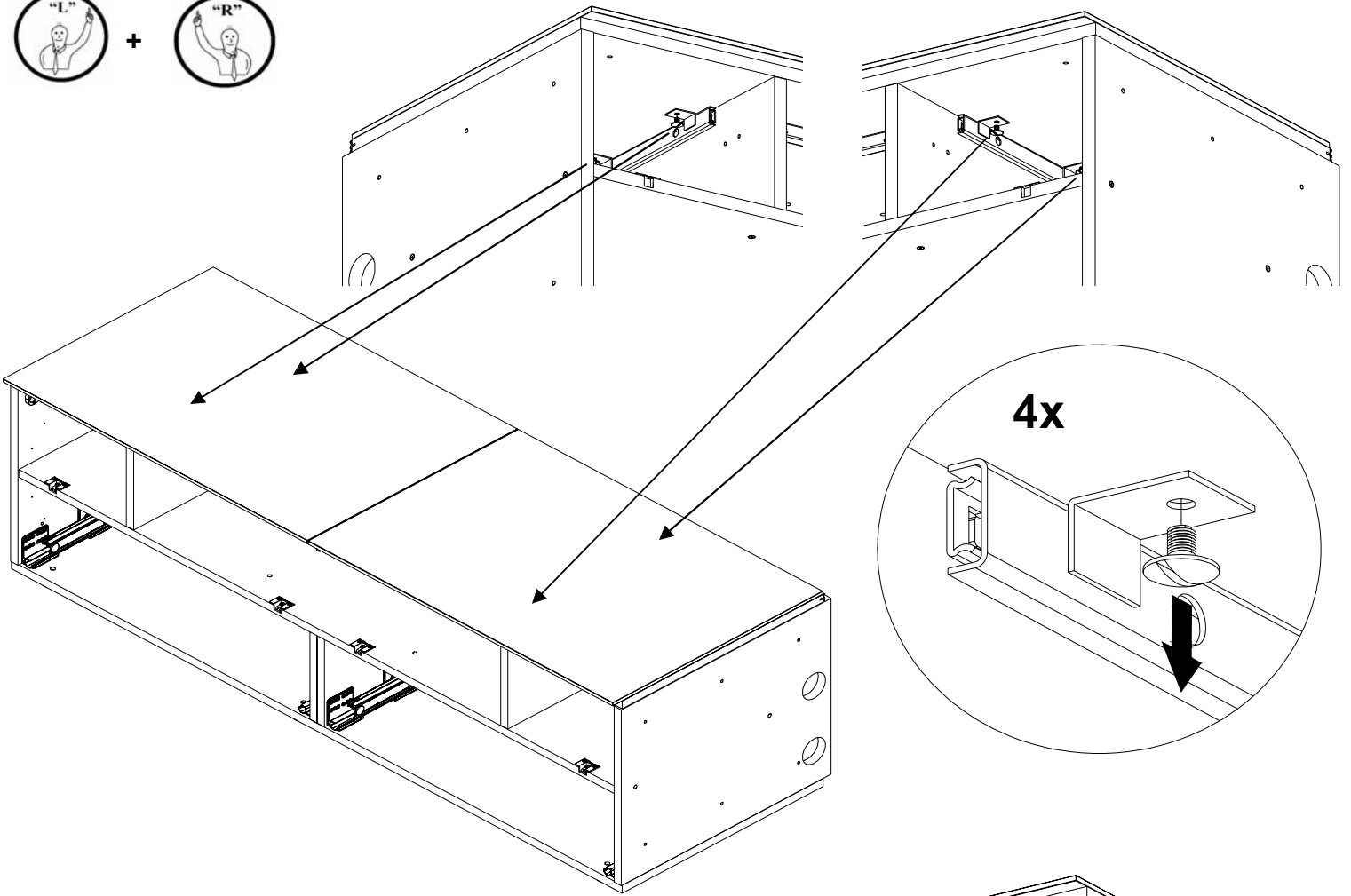
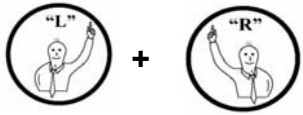

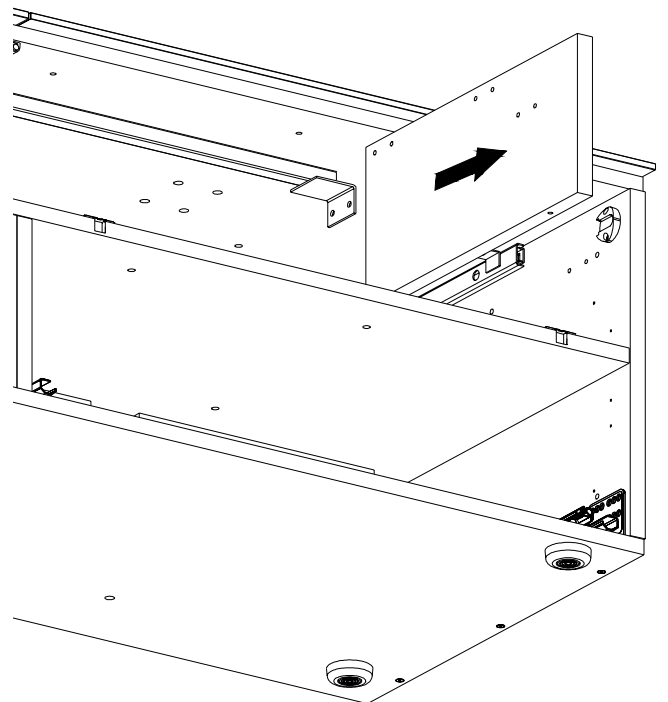
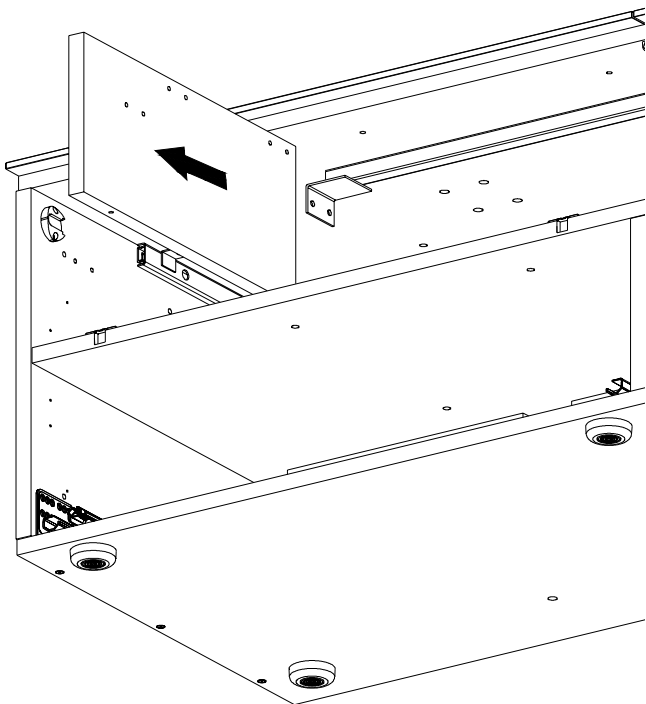
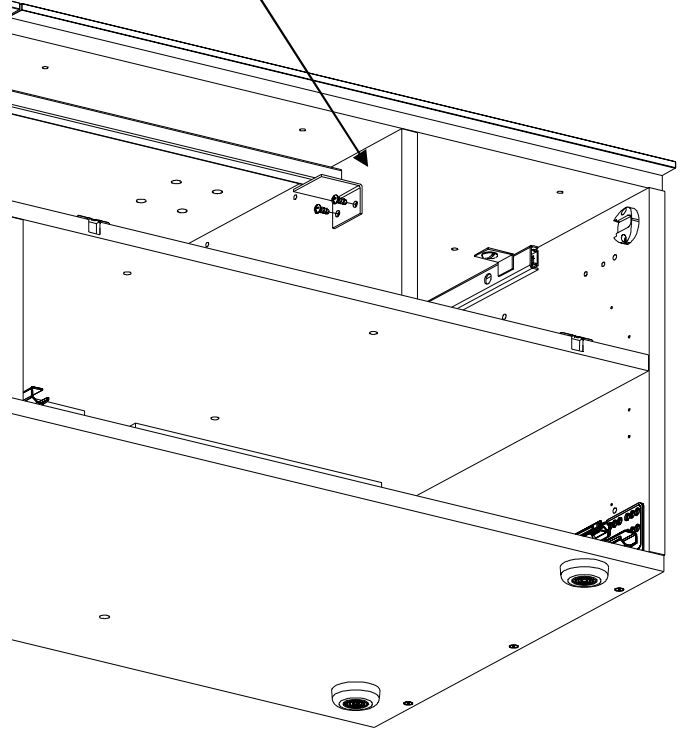
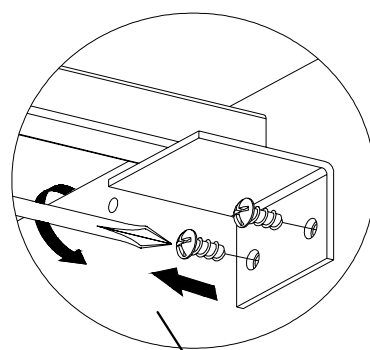
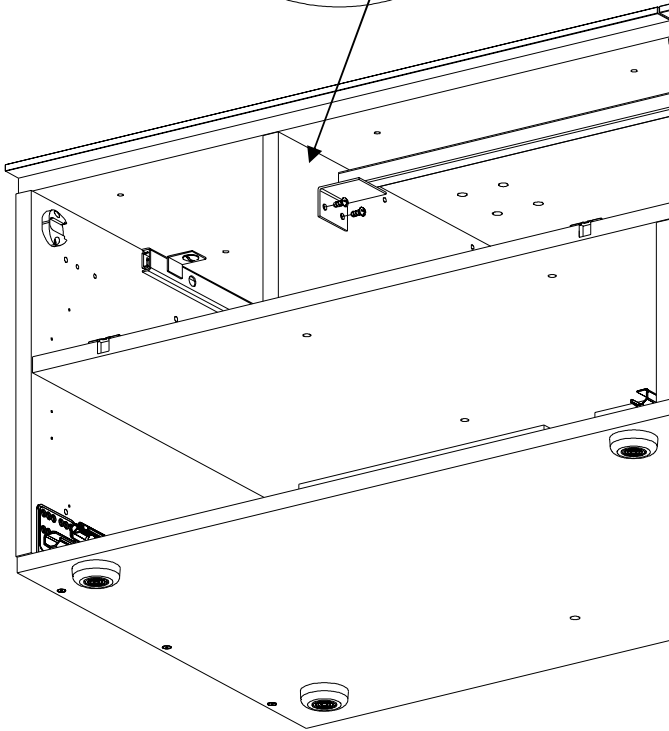
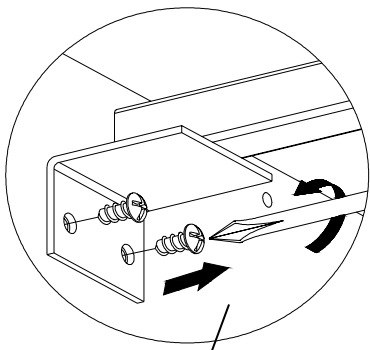

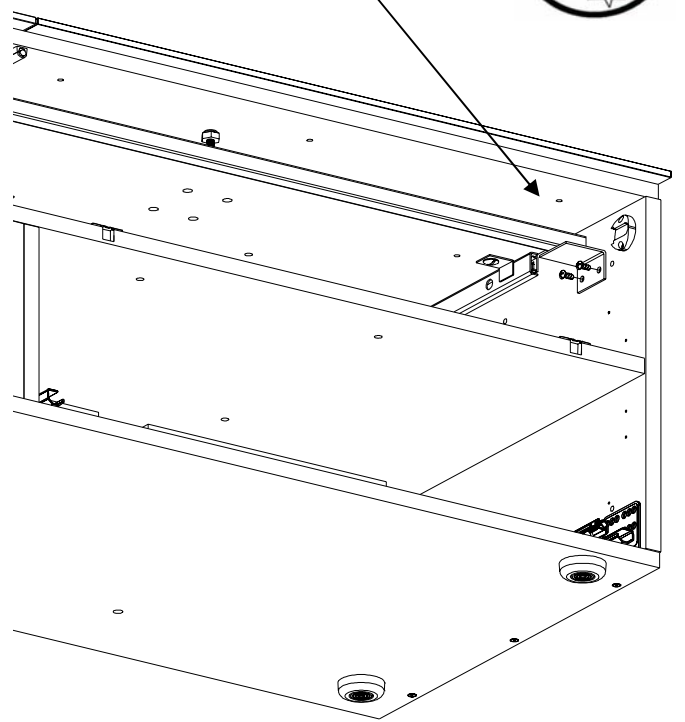
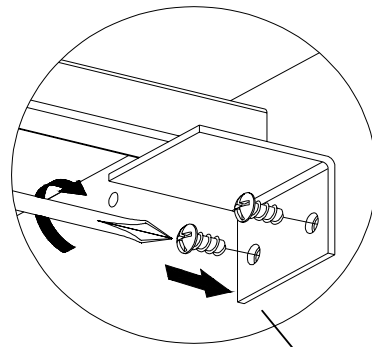
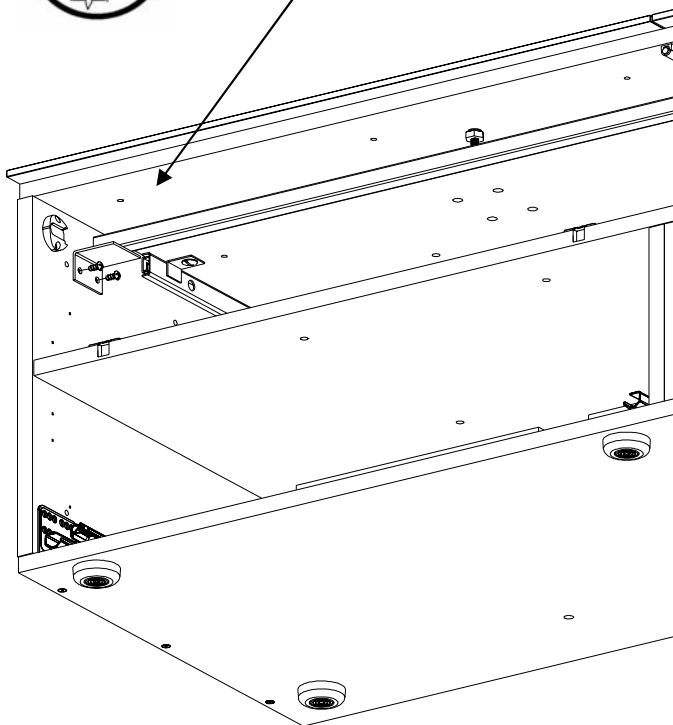
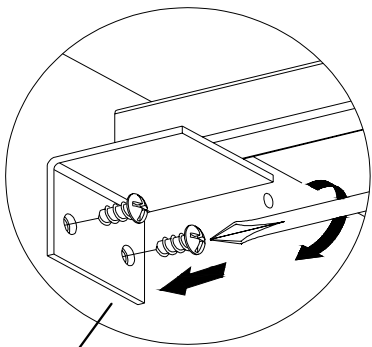
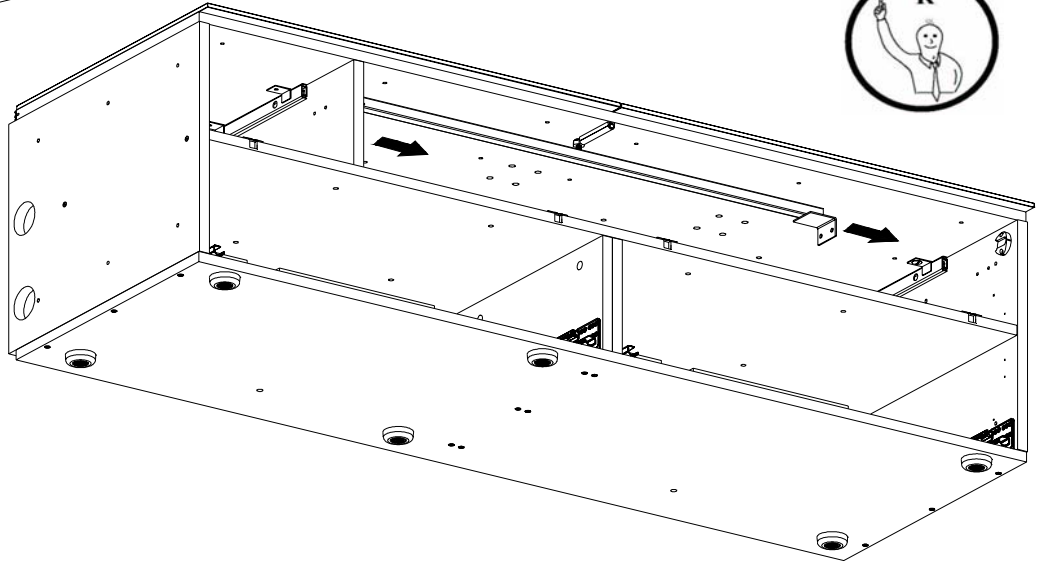
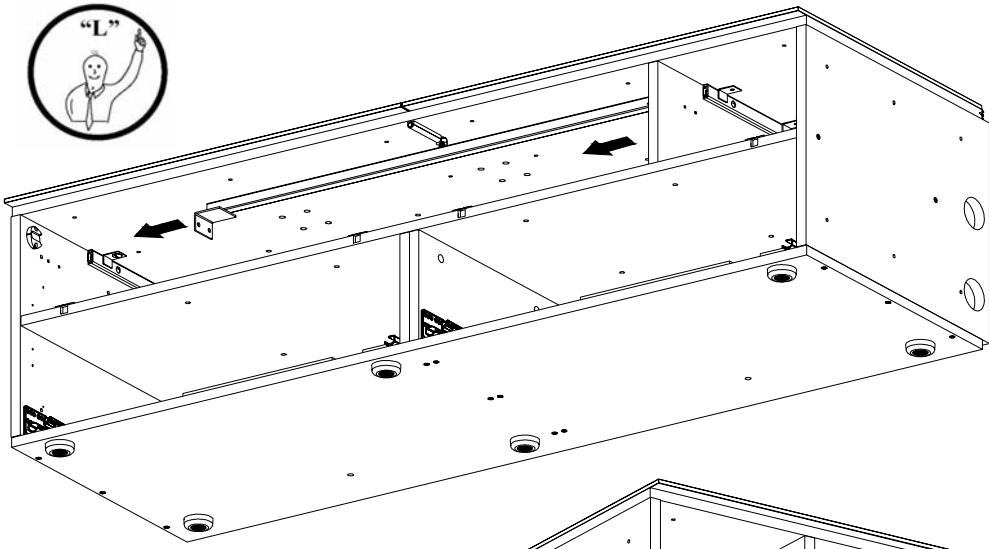

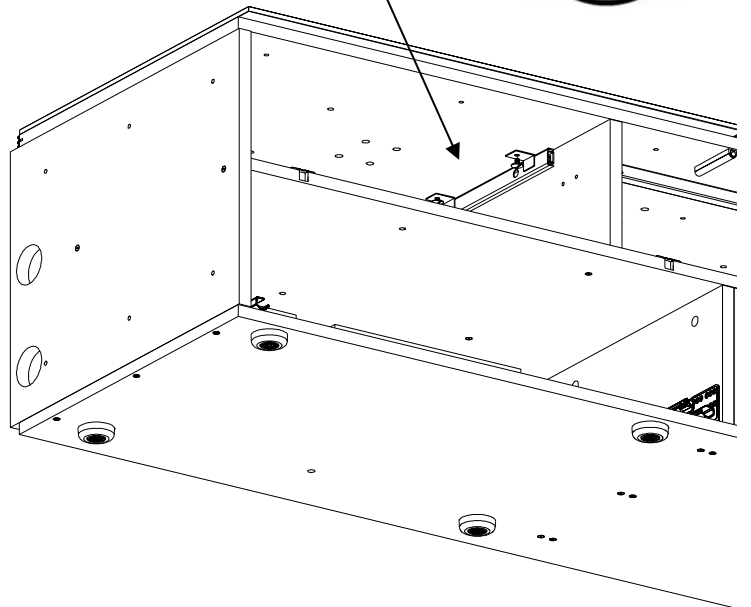
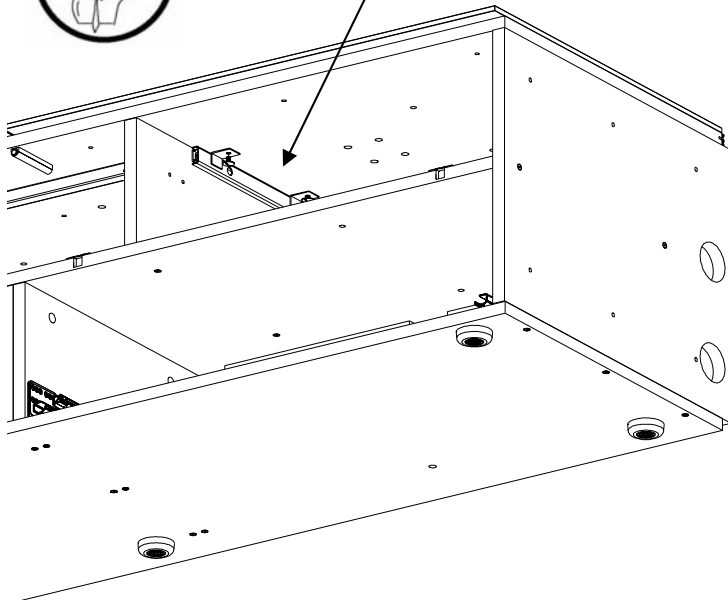
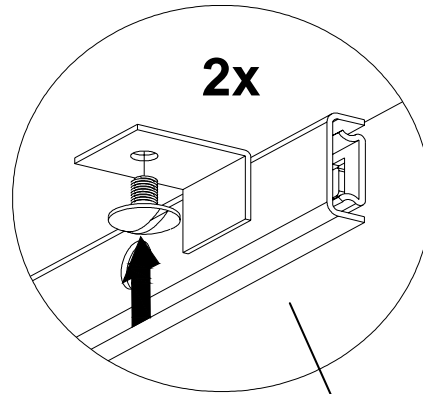
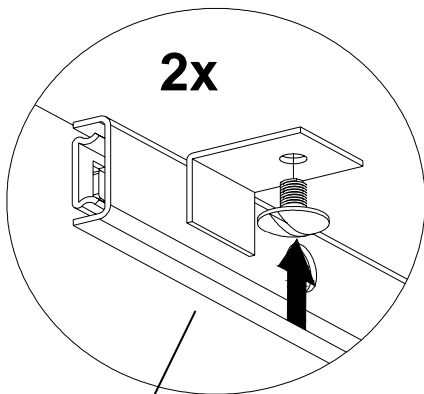
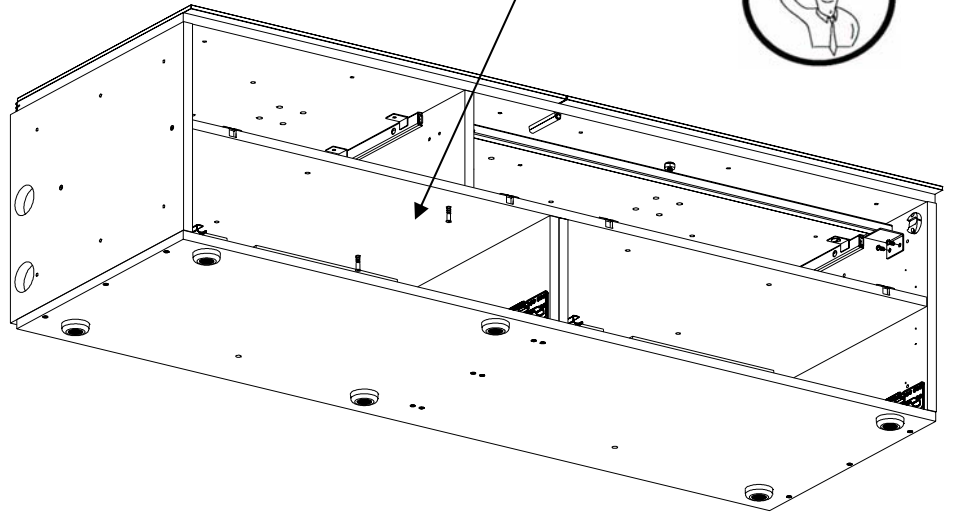
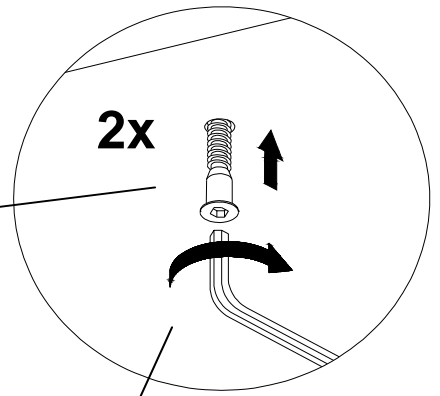
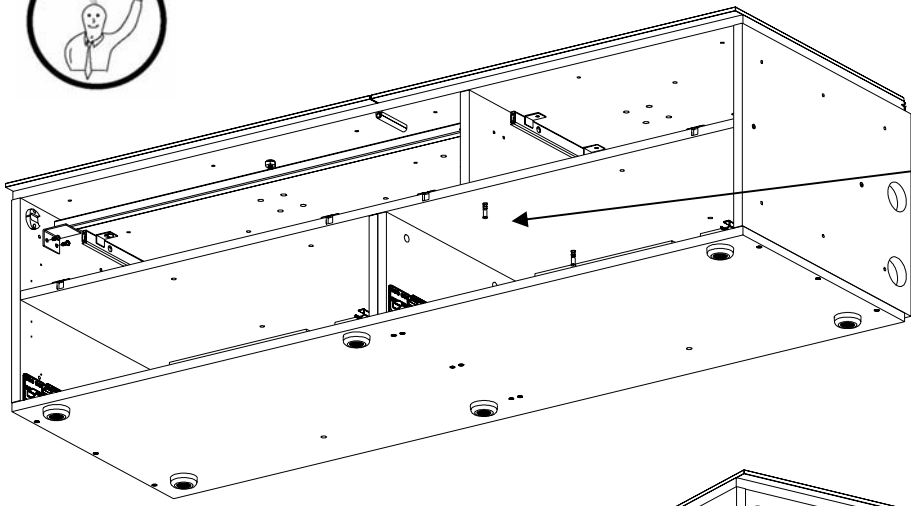

# Beschlagteile optional !

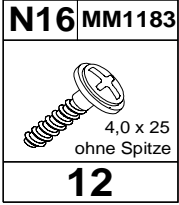

**Achtung:**  
Schrauben in  
schwarz !

**Attention:** black  
screws !

Die Schrauben zur Befestigung der Abschluss-  
seiten nur mit einem Handschraubendreher  
anziehen.  
**Keinen Elektro- oder Akkuschrauber verwenden.**

**Only use a hand screwdriver to attach the screws .  
Do not use an electric or cordless screwdriver.**

**Beispiel Art. 617:**  
**Example Art. 617:**

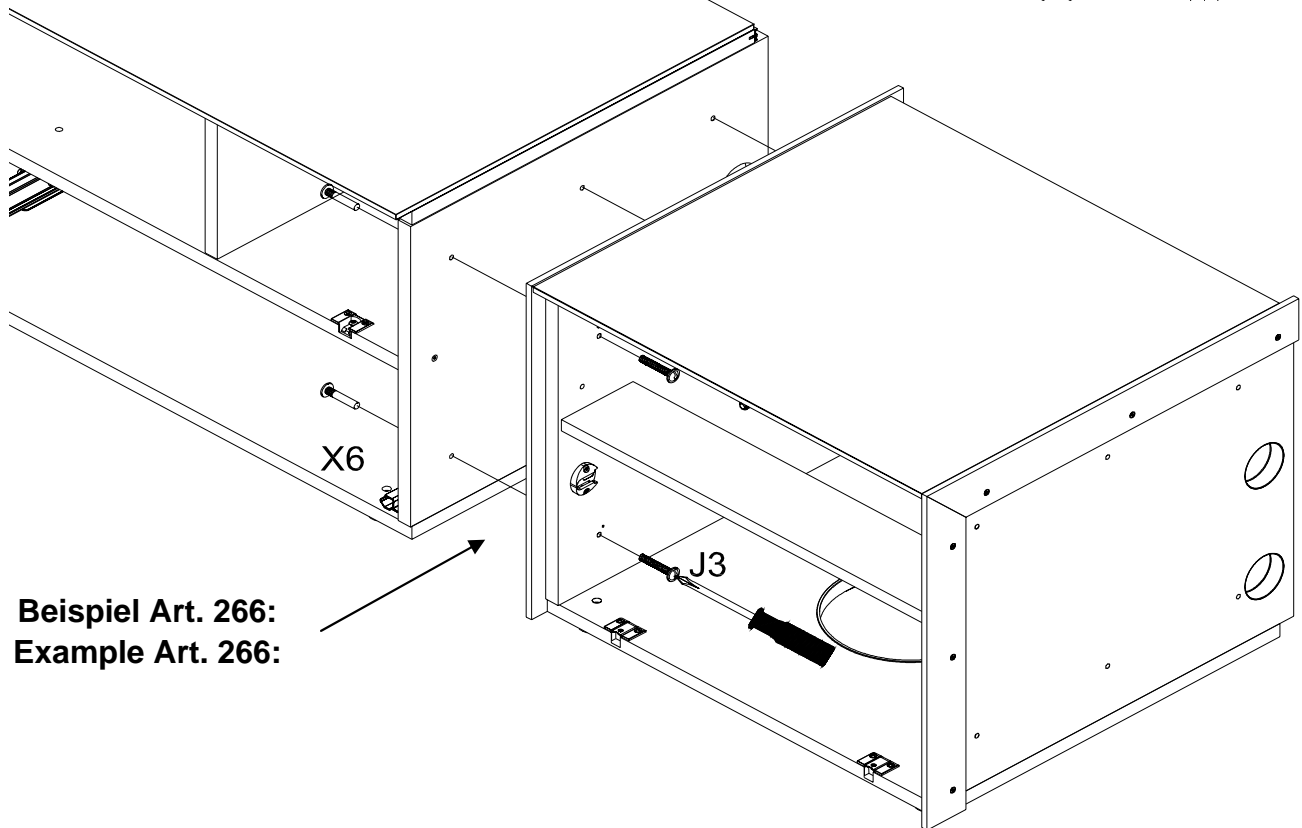
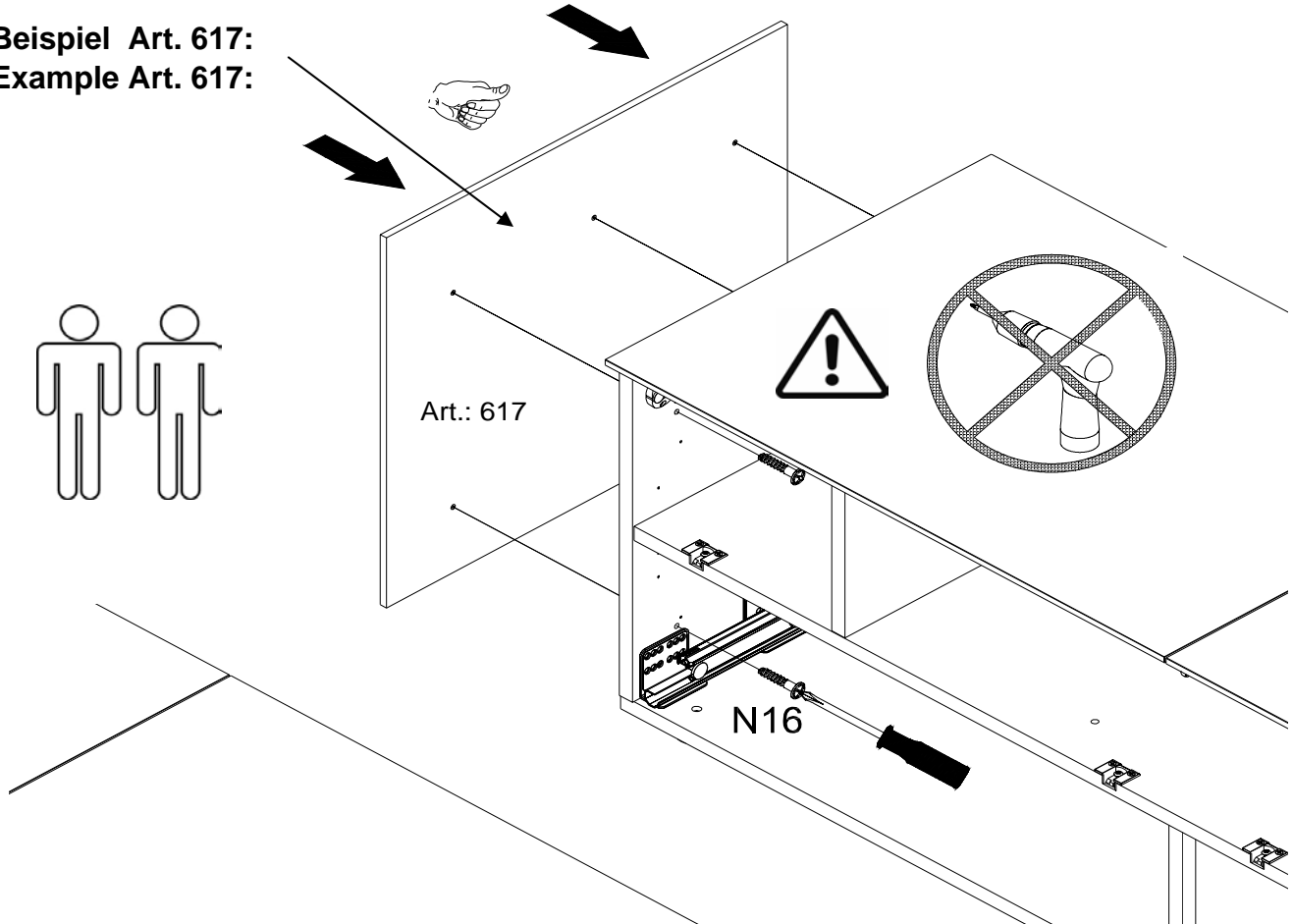
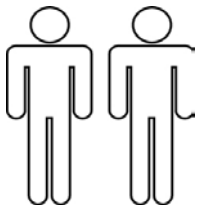

**Beispiel Art. 266:**  
**Example Art. 266:**

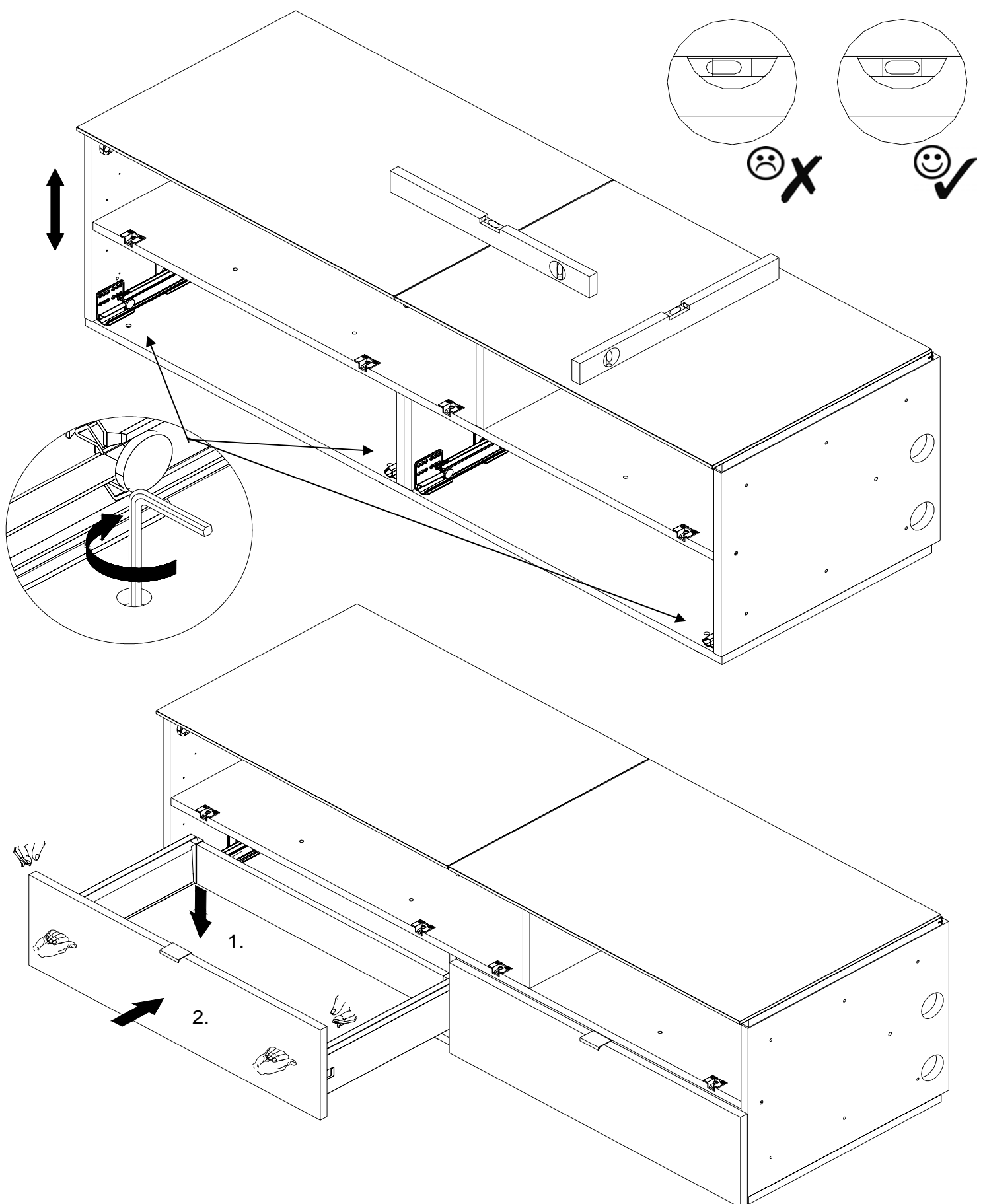

**Montagehinweis:**

Die Auszüge in den Korpus hinein schieben, wie bei geschlossener Stellung.  
 Dann den Stahl-Schubkasten auf die Auszüge legen und fest in den Schrank schieben,  
 bis das System einrastet.

**Assembly note:**

Put the Sliding statements into the cupboard as in the case of closed position.  
 Putting then the steel drawer on the statements and sliding into the cupboard tightly  
 until the system clicks in.

**Einstellung der Schubkästen:  
Adjustment of the drawers:**



**Verstellung der Front:  
Adjustment of the Front:**

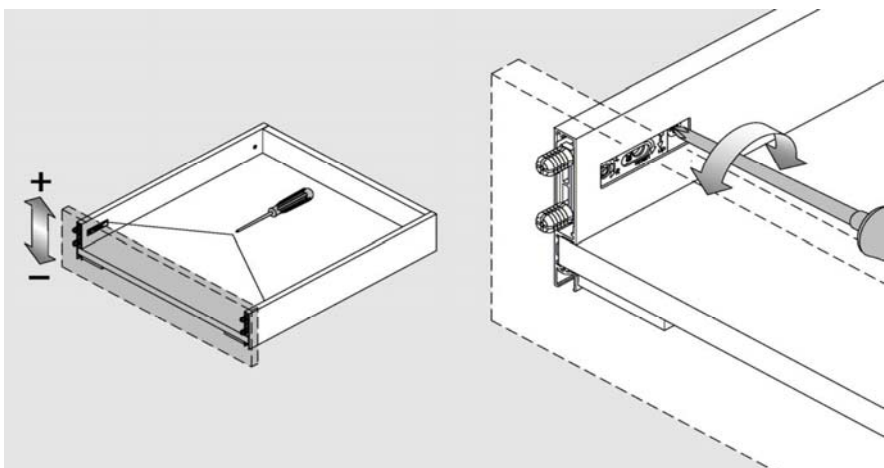

**Height**

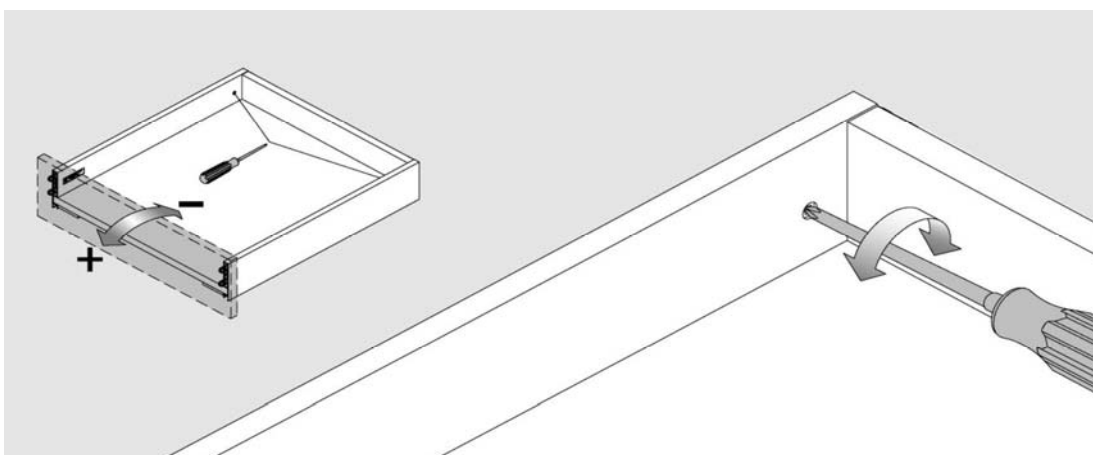

**Tipe**

**Auf beiden Seiten vornehmen/Adjust both sides/  
À faire des deux côtés/Eseguire su entrambi i lati/  
Realizar a ambos lados/Görs på båda sidorna**

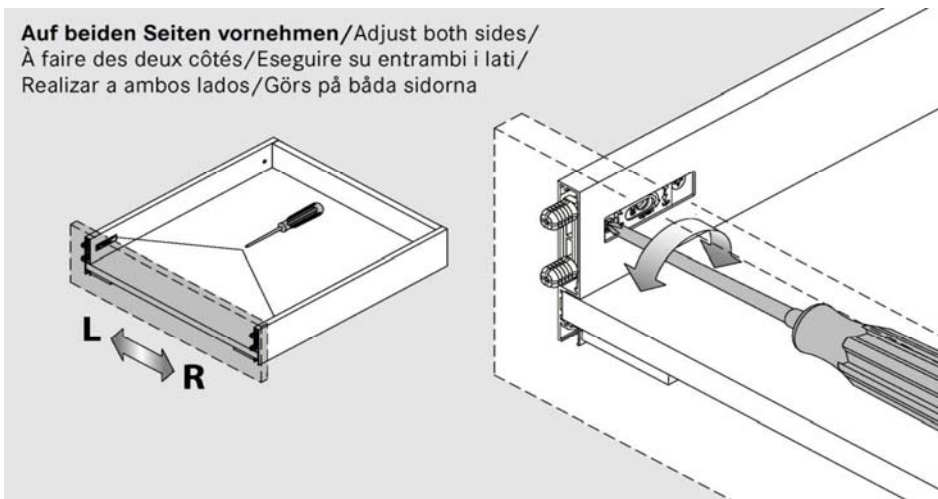

**Horizonta**

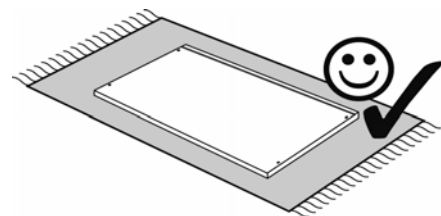

**Demontage der Front  
Dismounting of the Front**

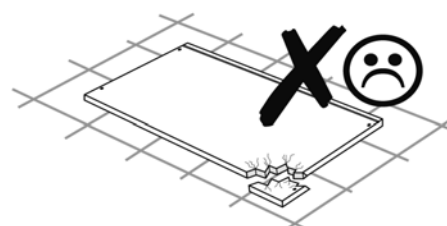
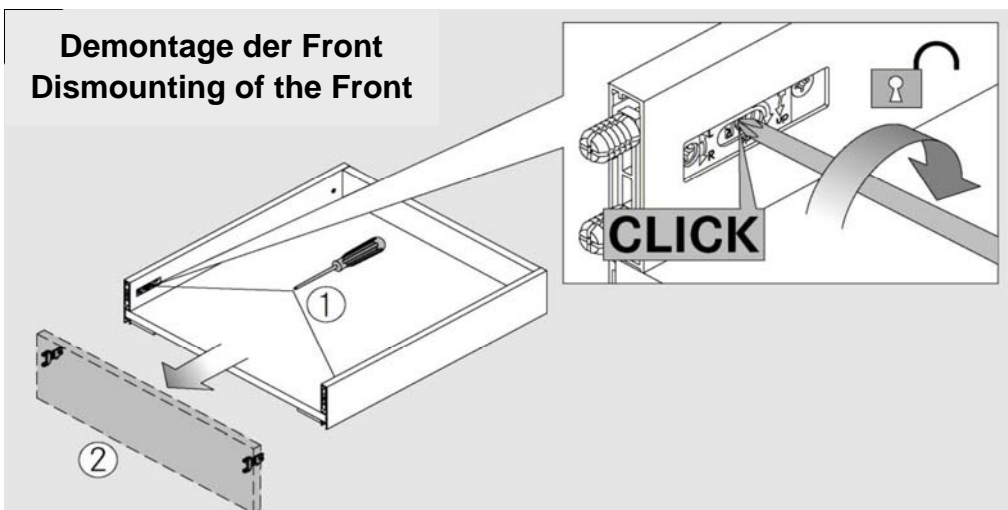

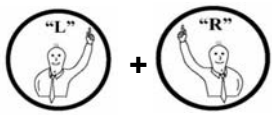

1.

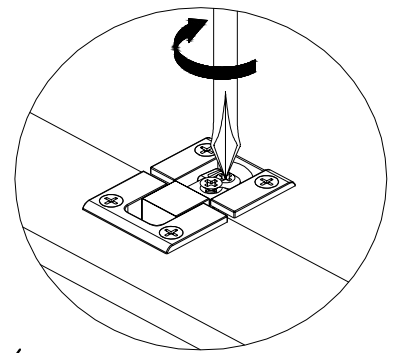
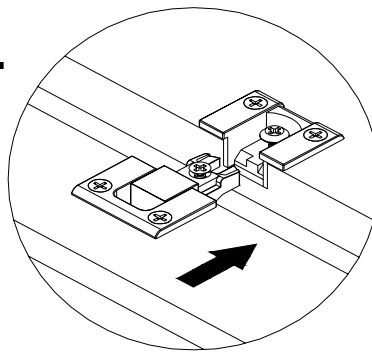

2.

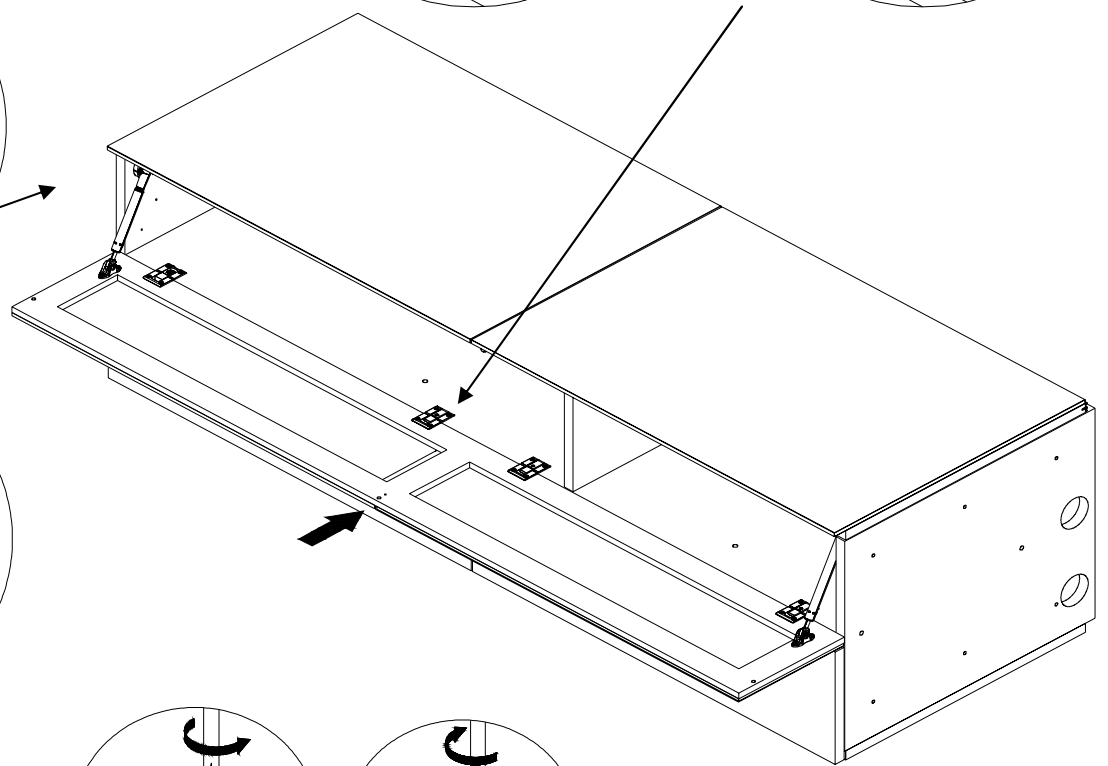
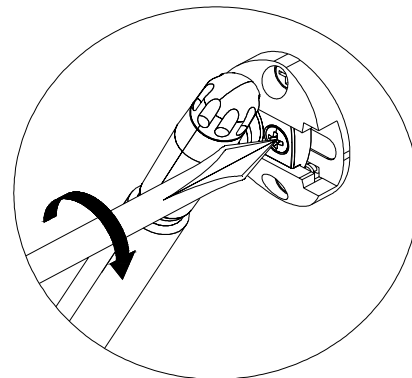
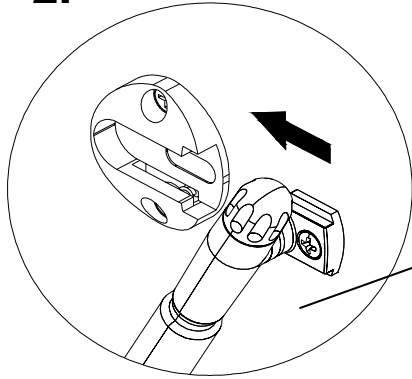

**Tiefenverstellung:**  
**Depth adjustment:**

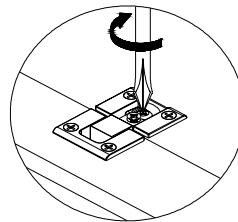
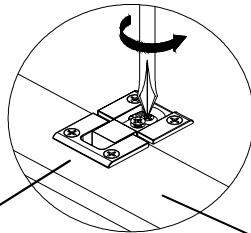

**Seitenverstellung:**  
**Horizontal adjustment:**

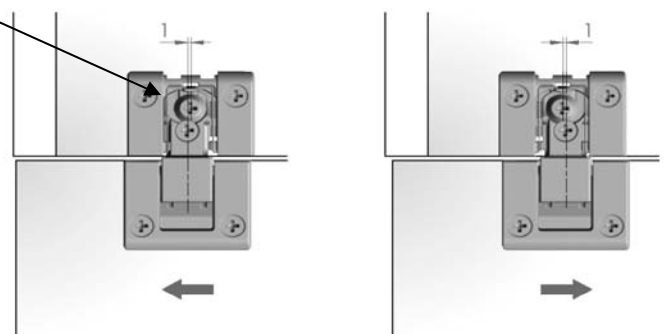
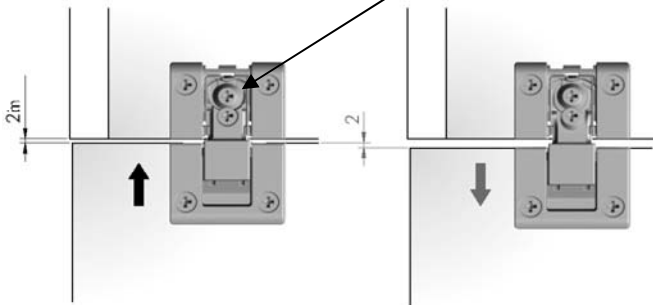

**Höheneinstellung:**  
**Height adjustment:**

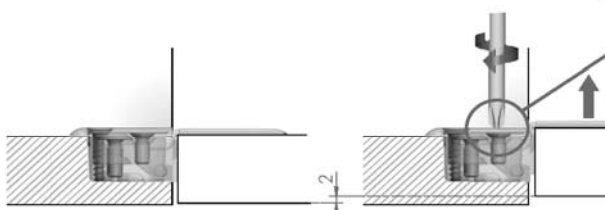
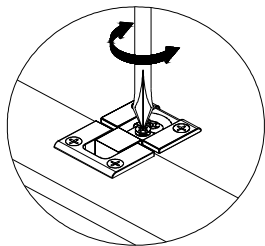

**Neigungsverstellung:**  
**Open angle adjustment:**

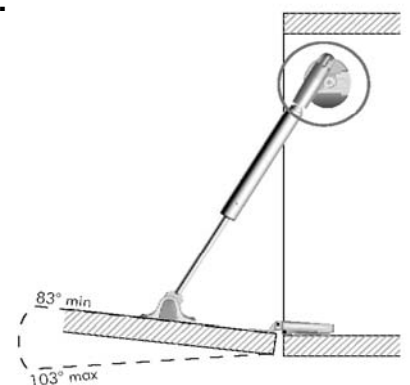
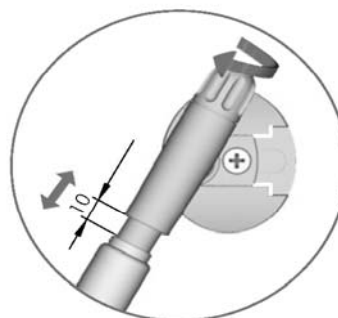



# Beleuchtung optional !

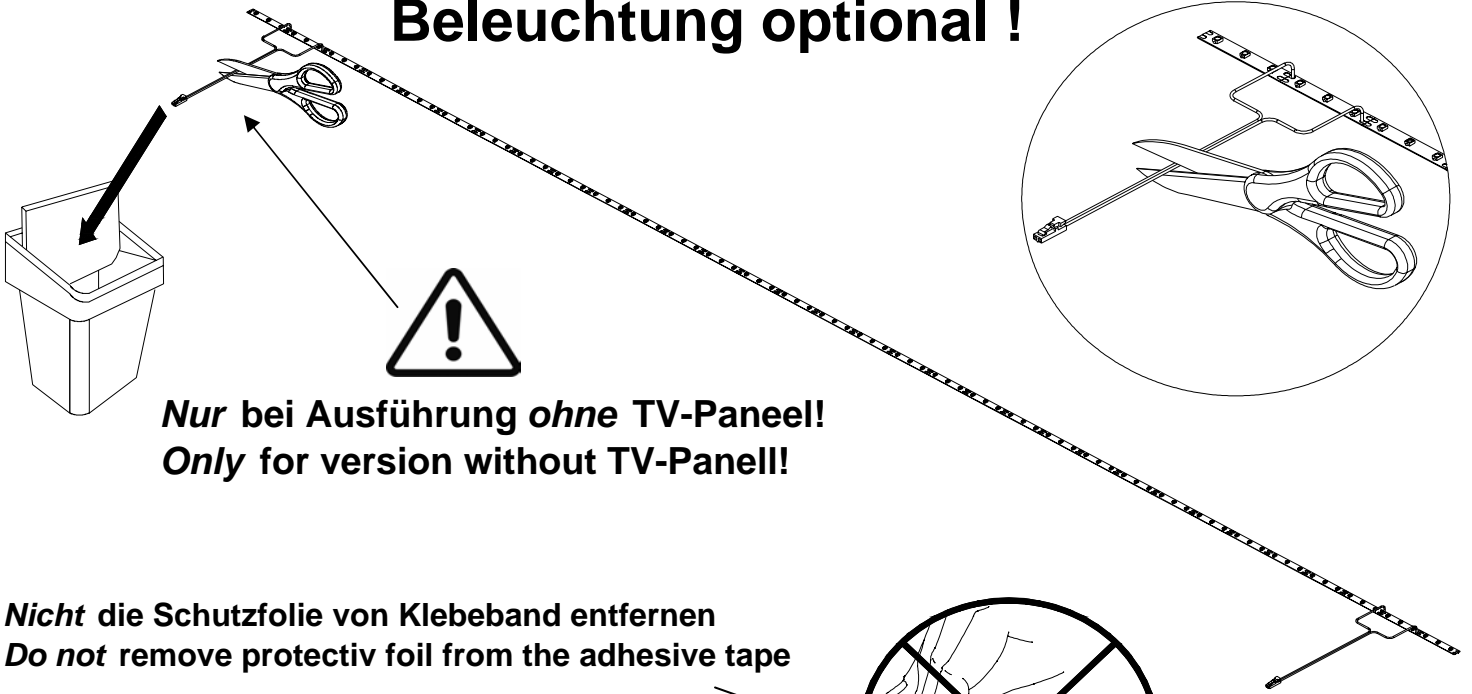

**Nur bei Ausführung ohne TV-Paneel!  
Only for version without TV-Panell!**

**Nicht die Schutzfolie von Klebeband entfernen  
Do not remove protectiv foil from the adhesive tape**

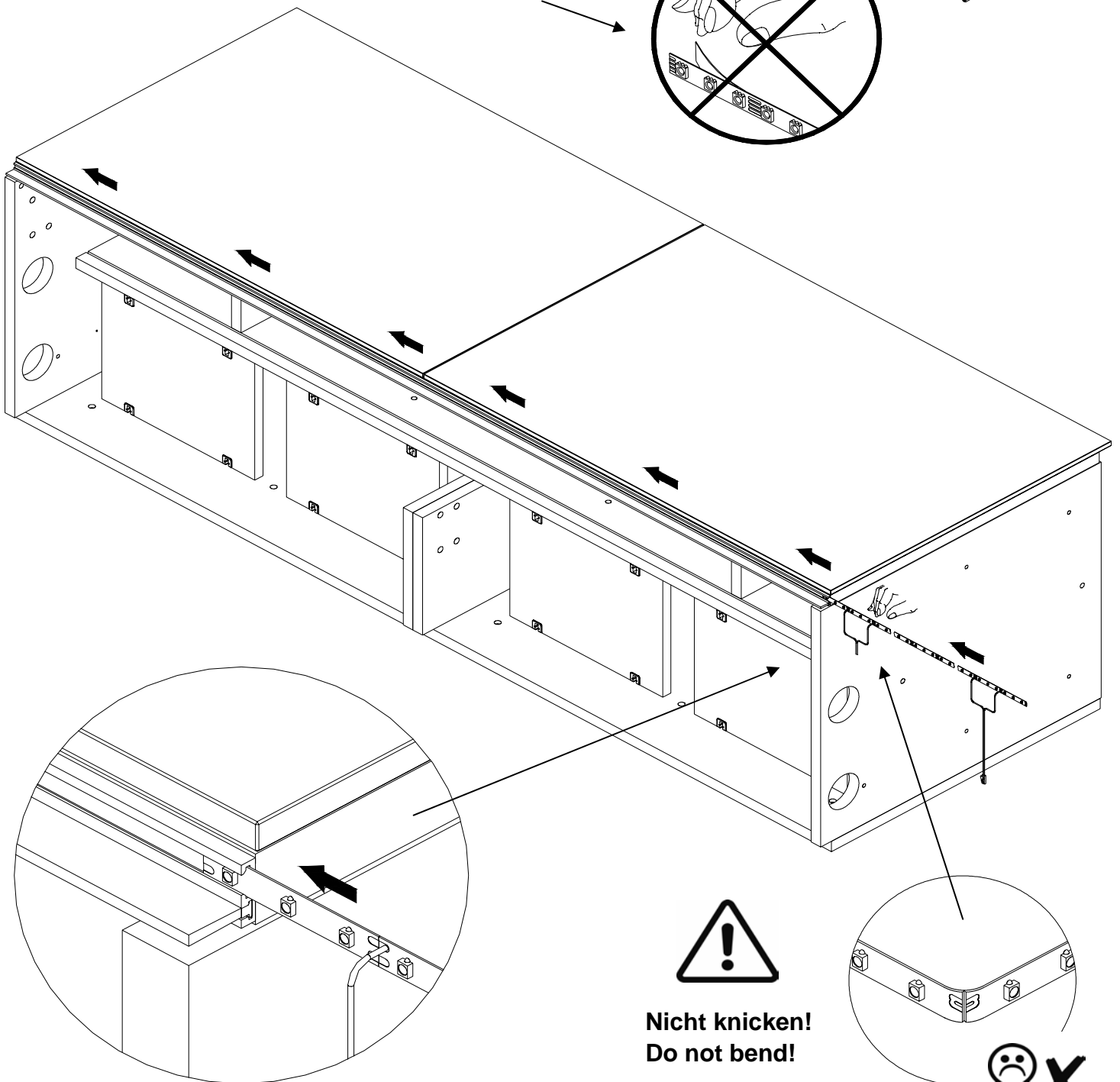

**Nicht knicken!  
Do not bend!**

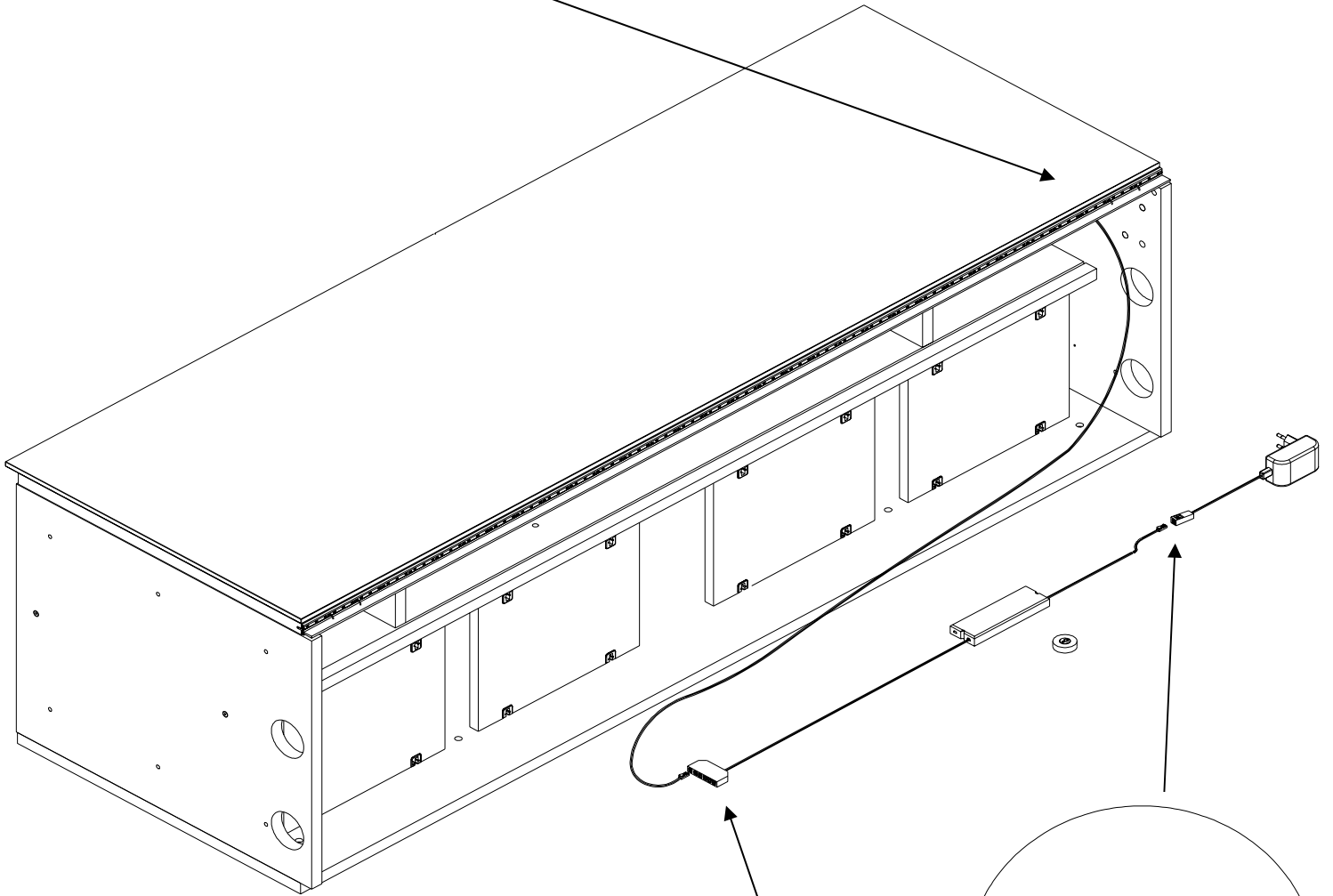
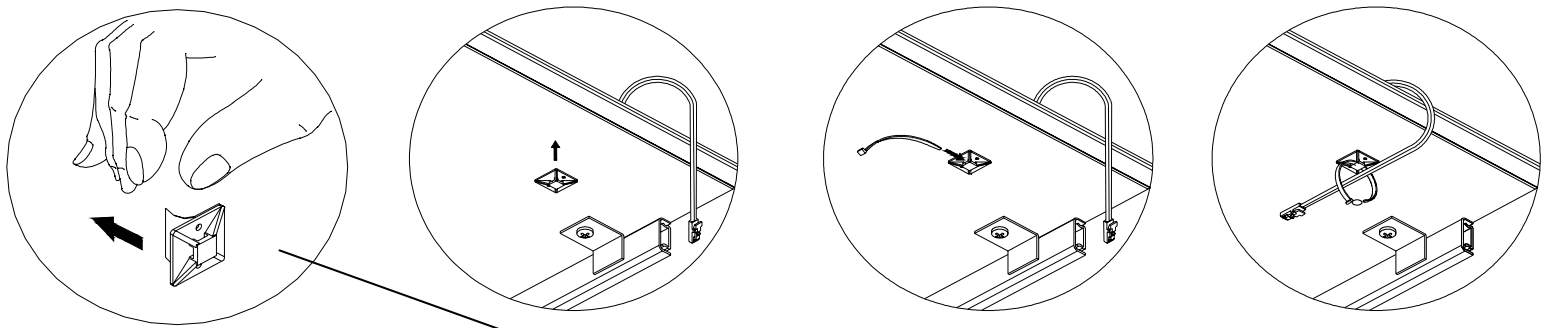

**1. Schutzfolie der Batterie entfernen  
=> Inbetriebnahme !**

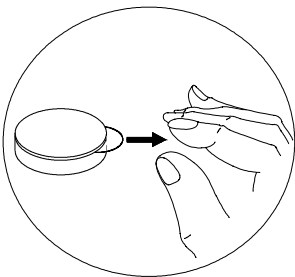
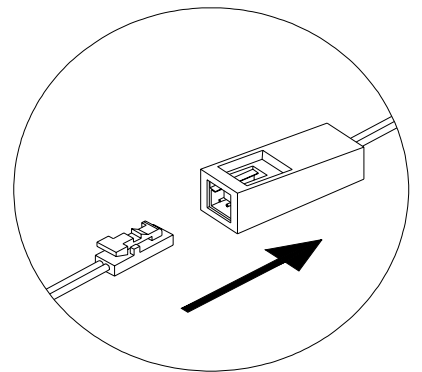
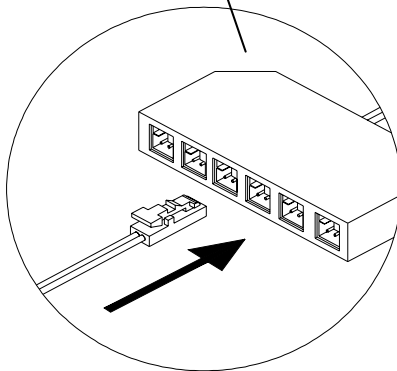

**2.: Kurzer Druck : An / Aus  
Short press: On / Off**

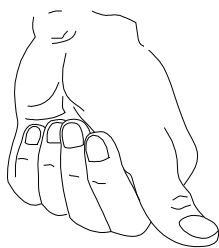

**3.: Langer Druck: Dimmer heller / dunkler  
Long press: Up / Down dimming**

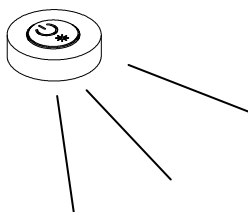

# TV-Panel optional !

Typ 192:

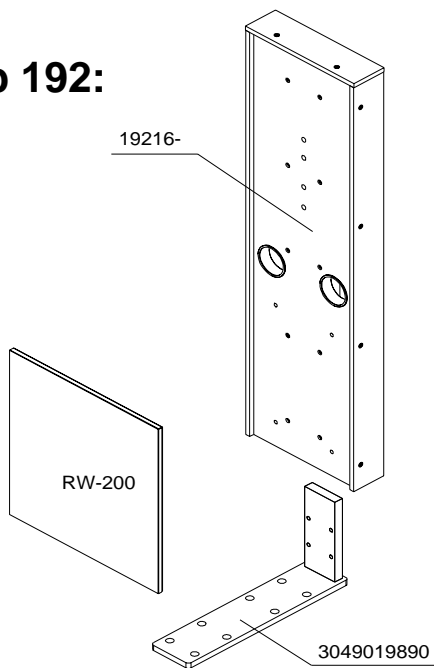

Typ 194:

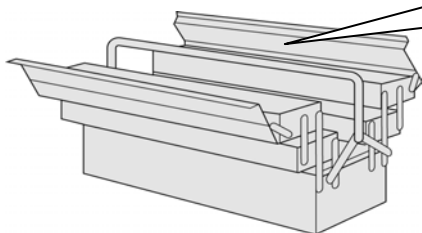
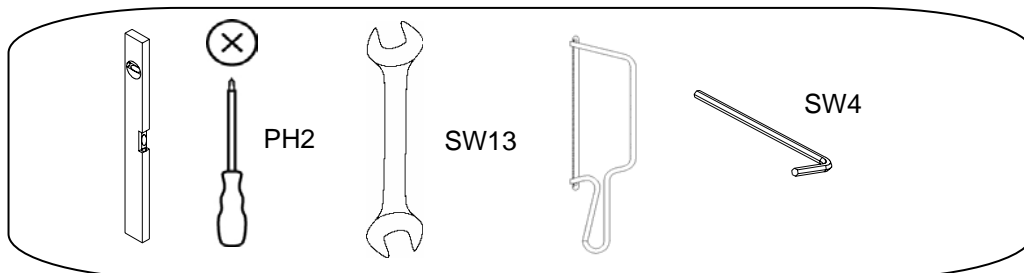
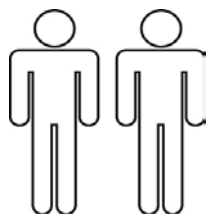
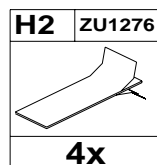
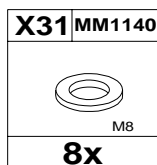
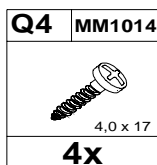
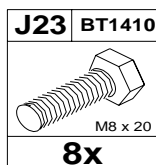
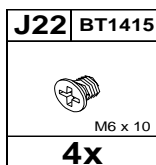
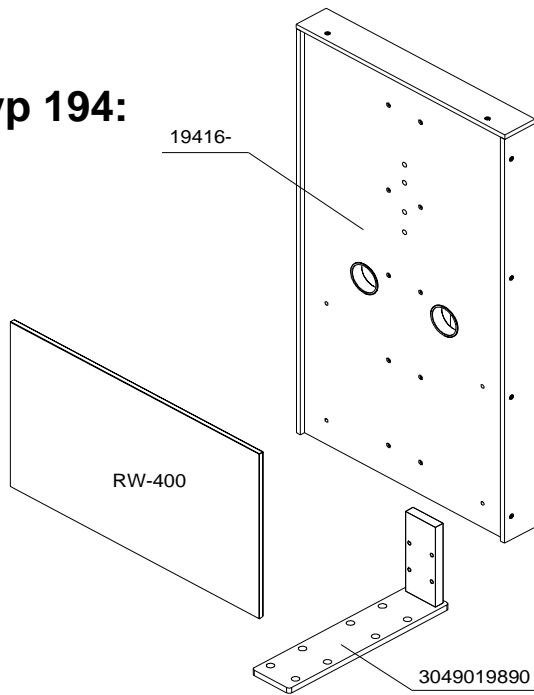

wahlweise / optional:

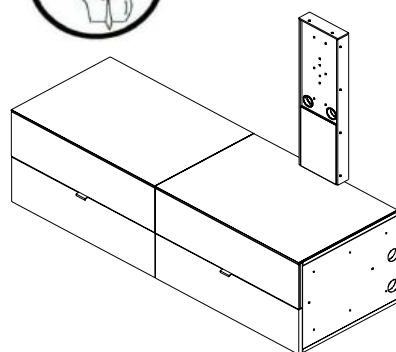
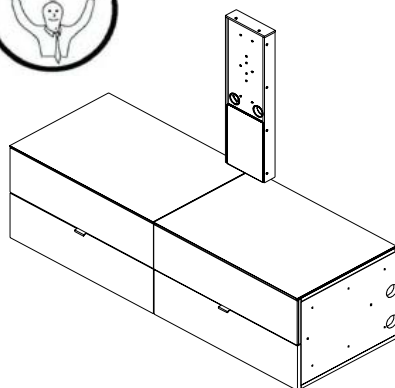
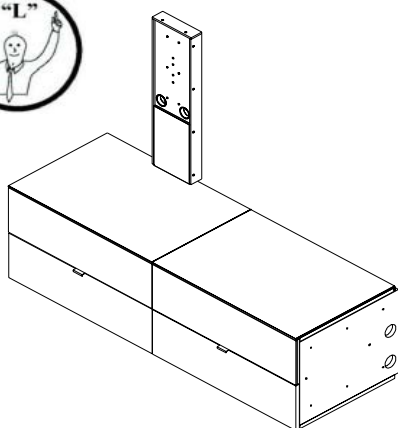

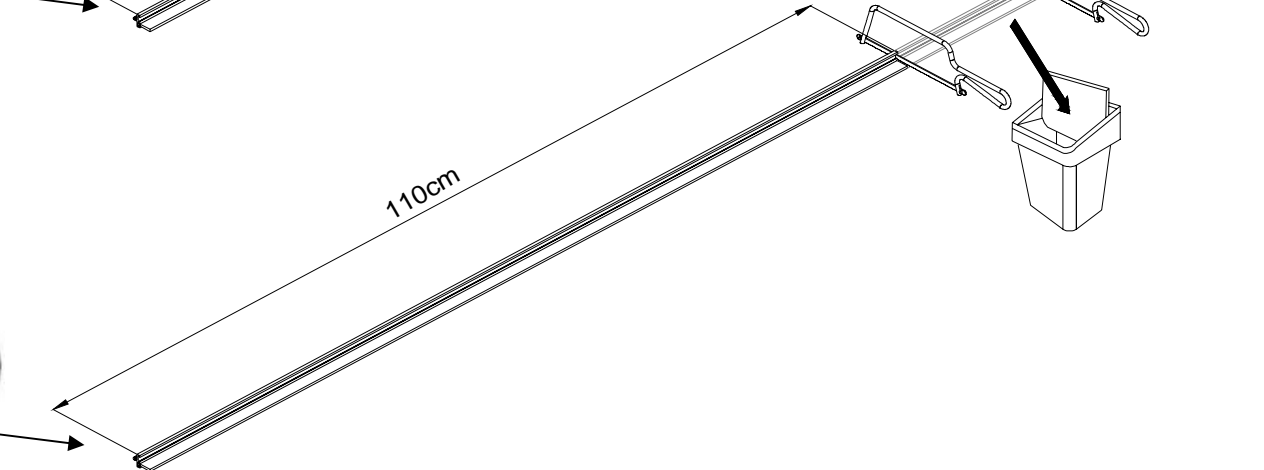
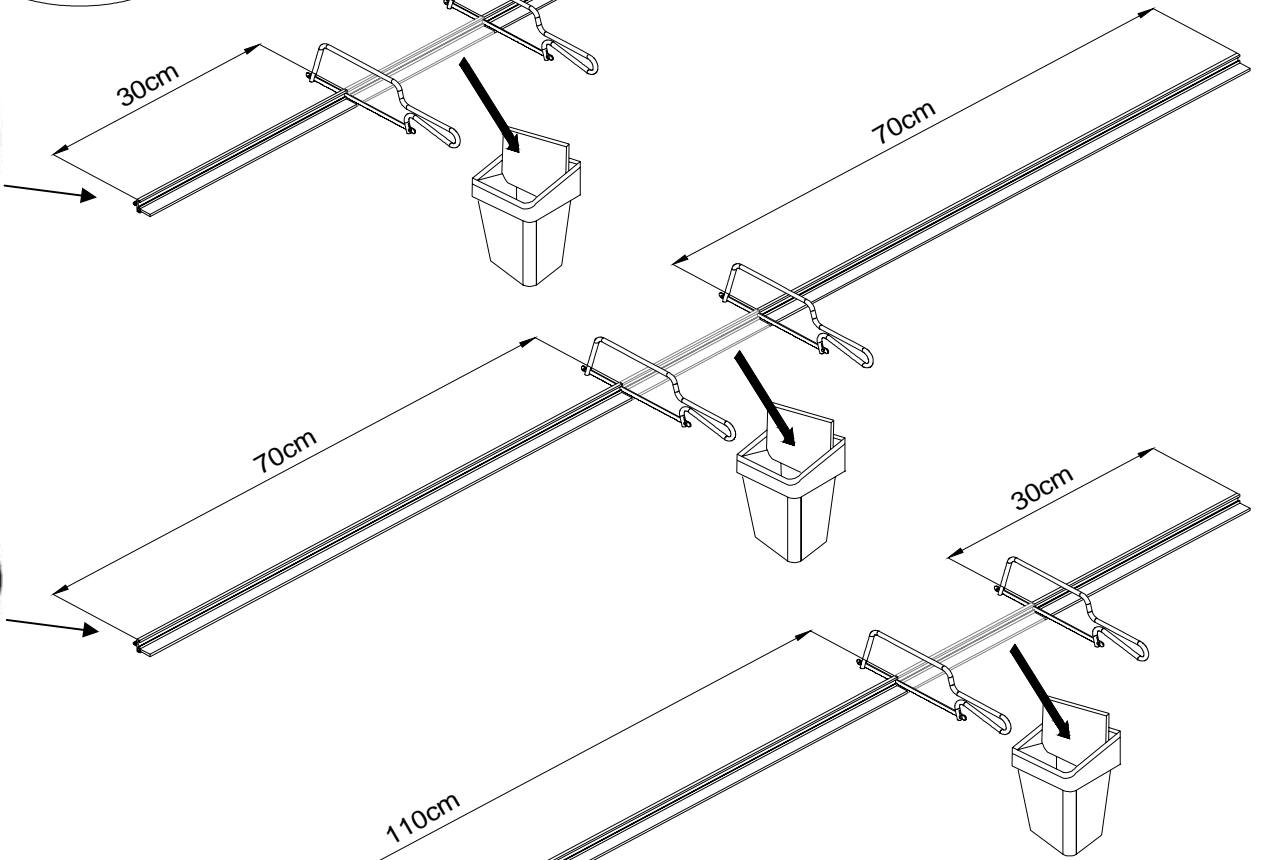
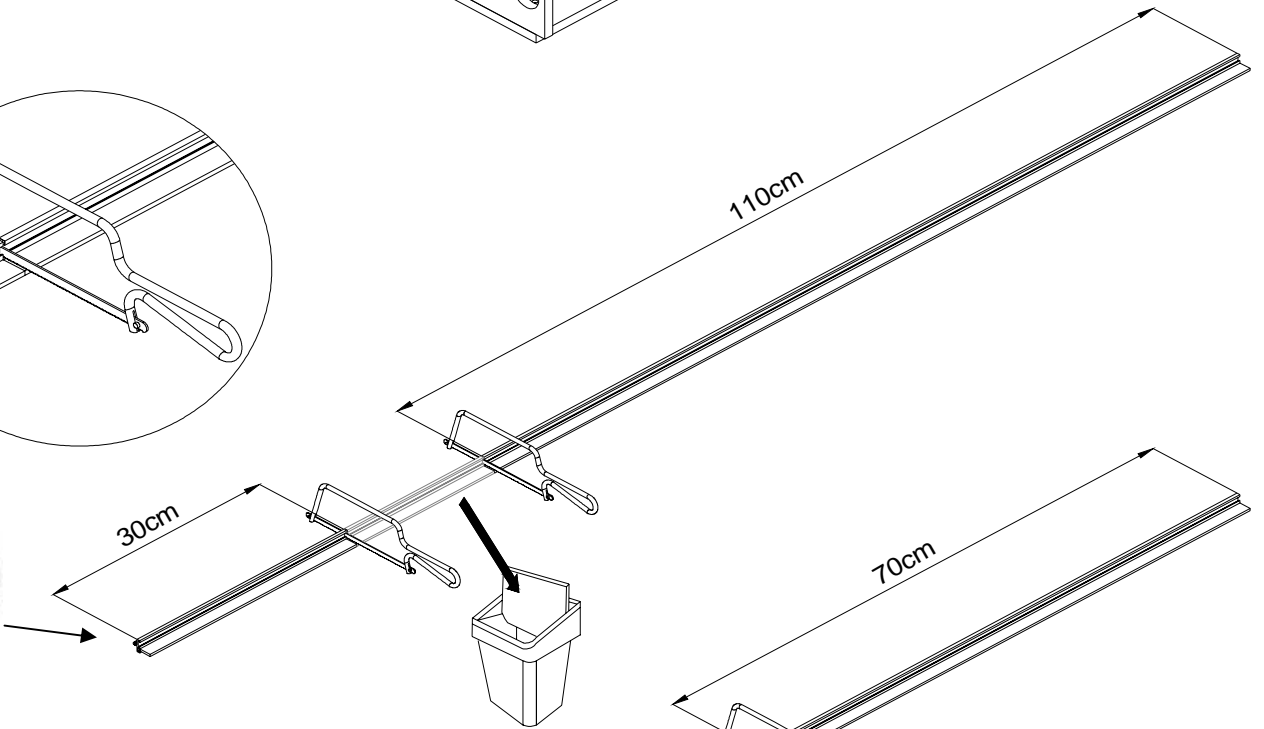
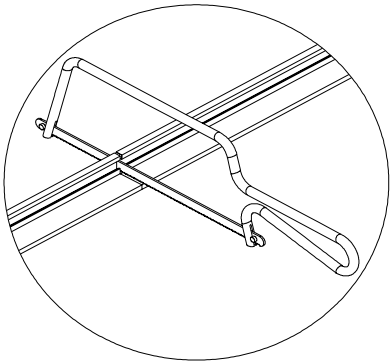
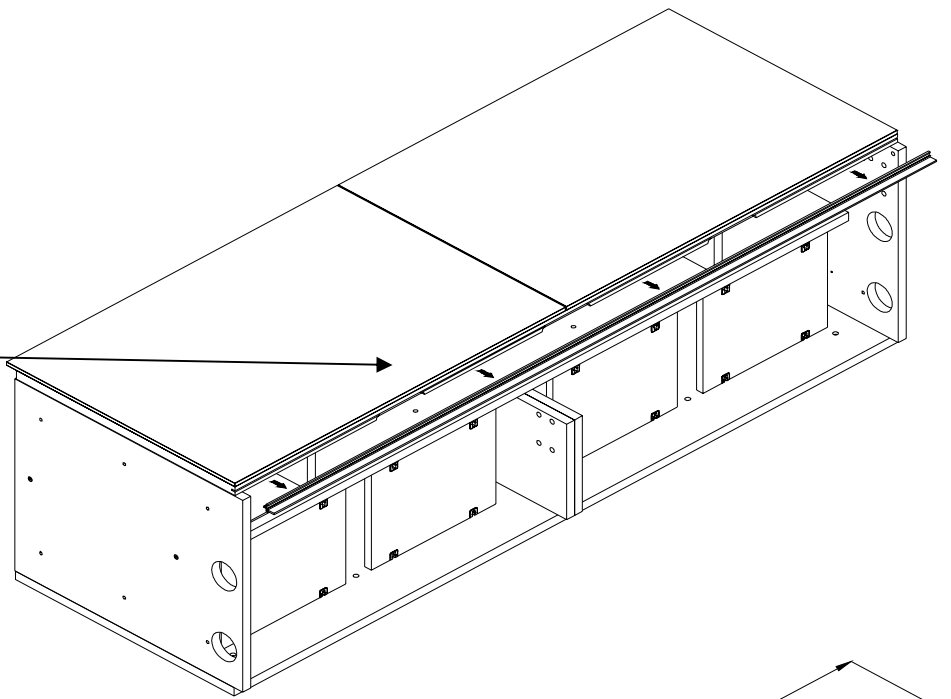
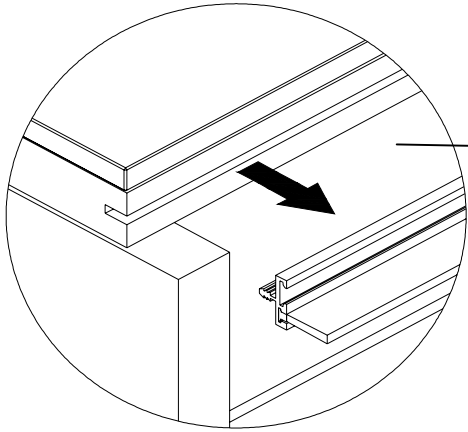

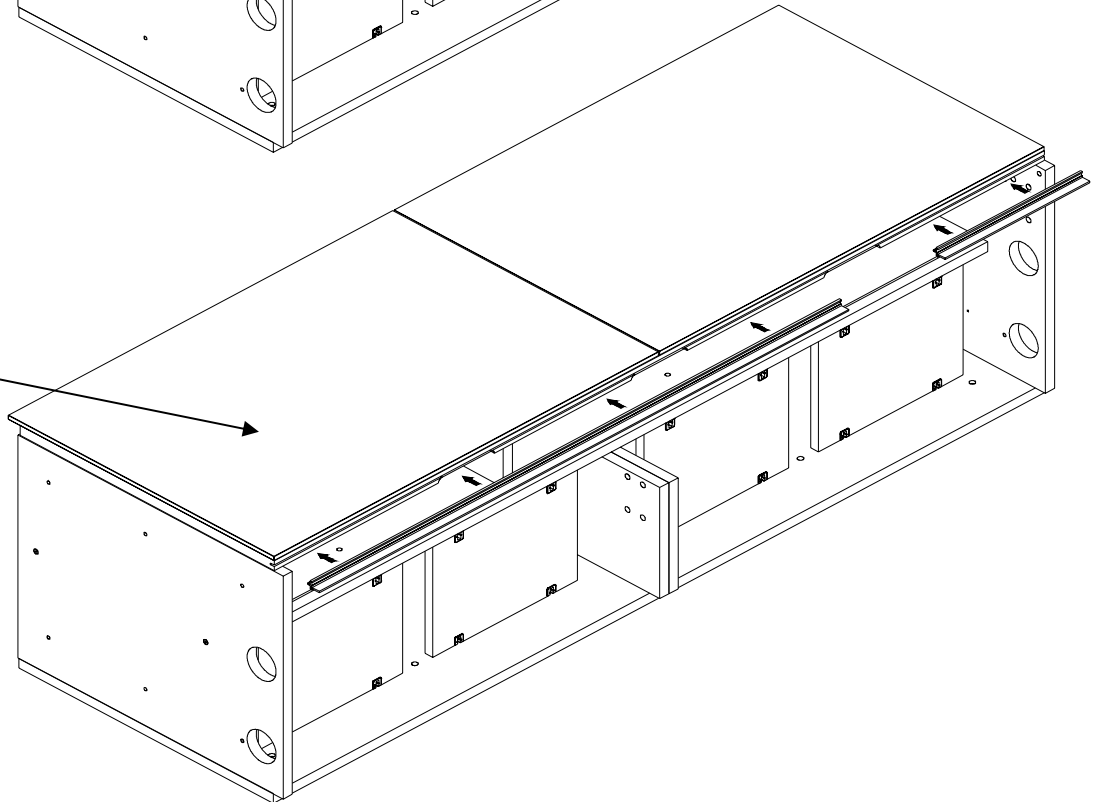
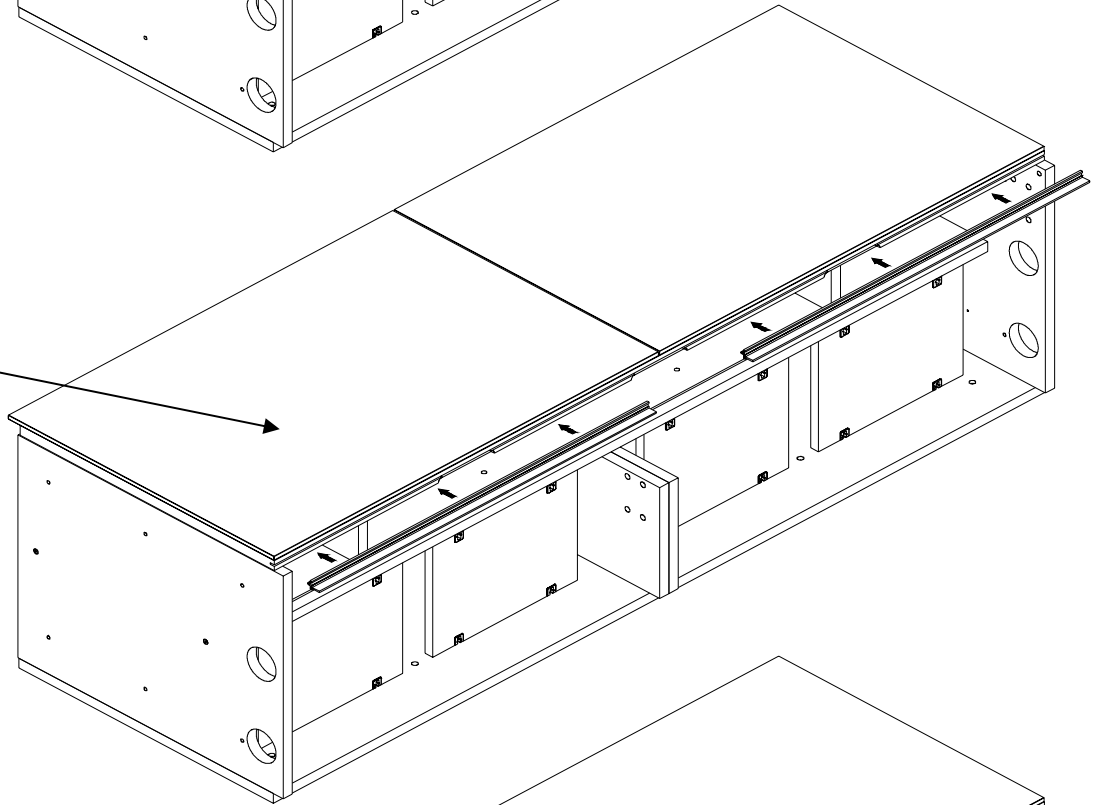
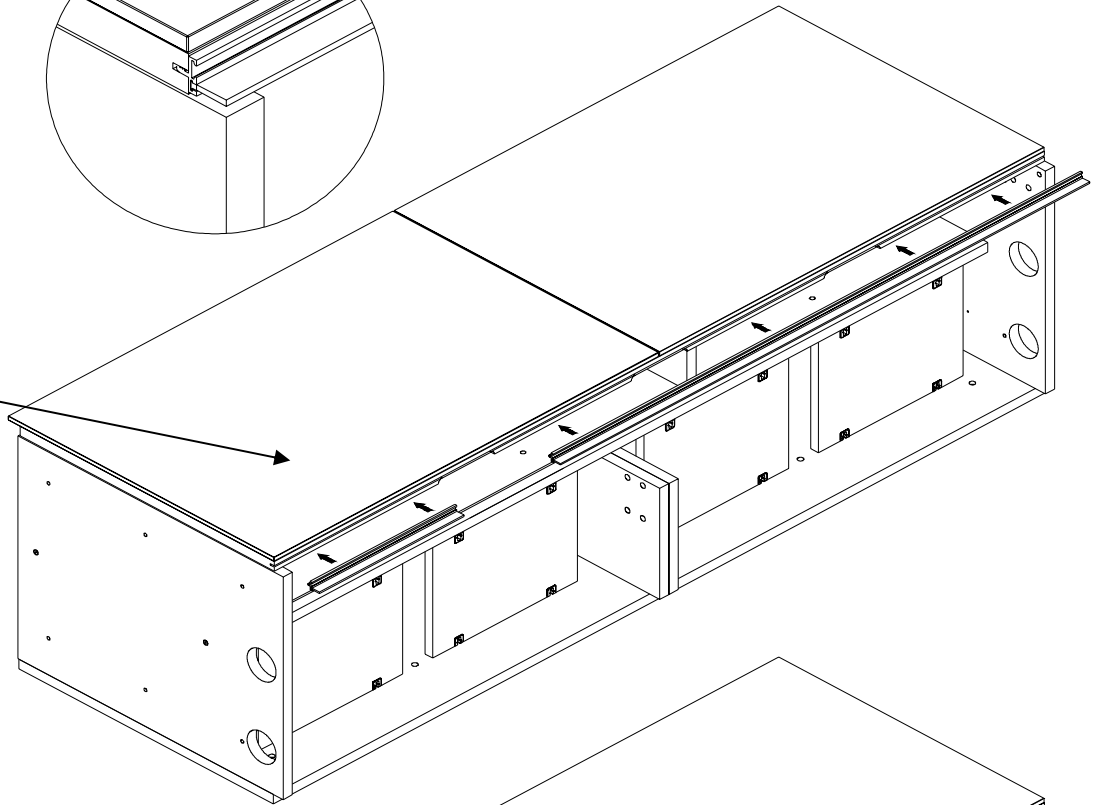
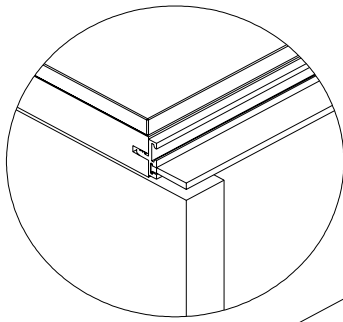
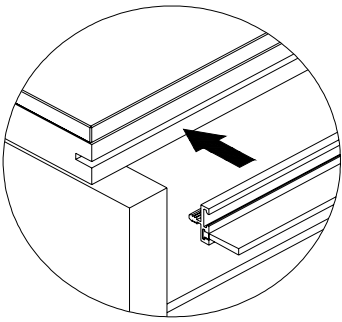

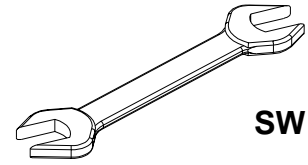
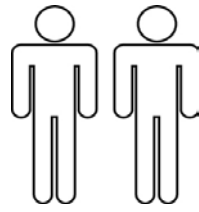
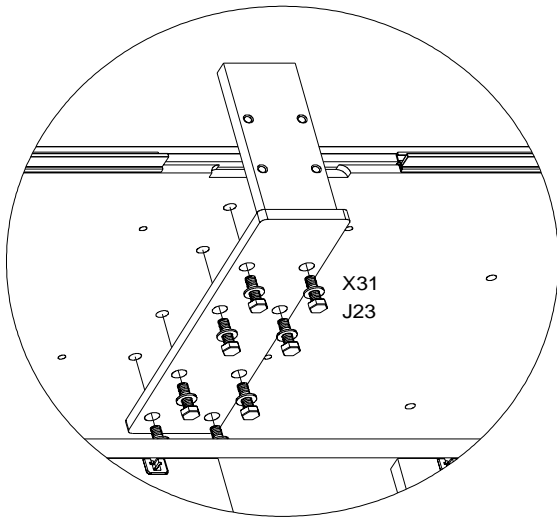

SW 13

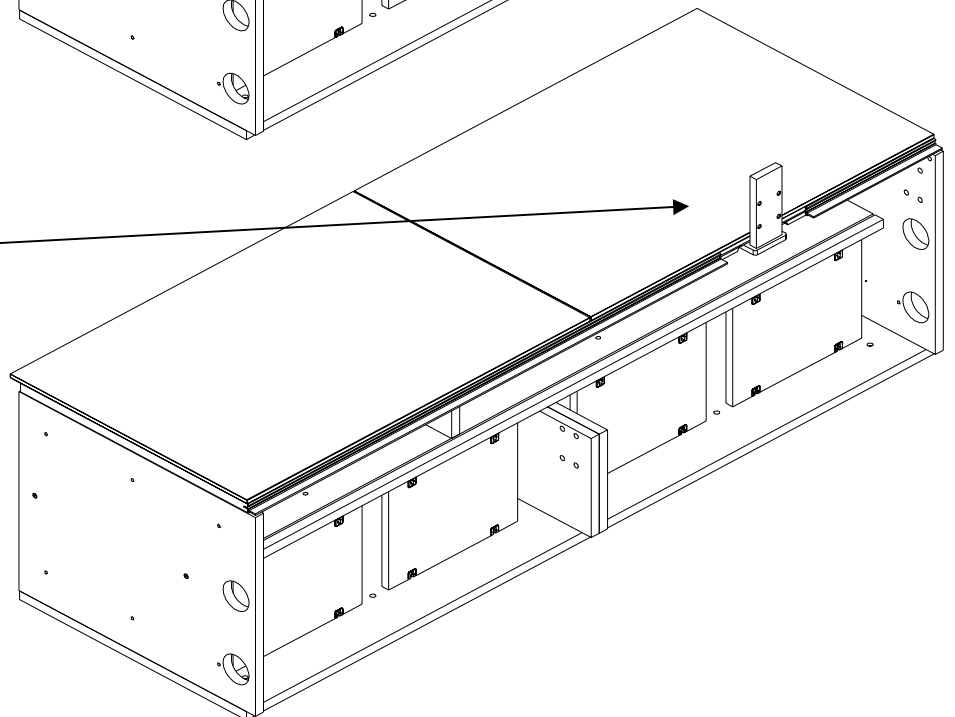
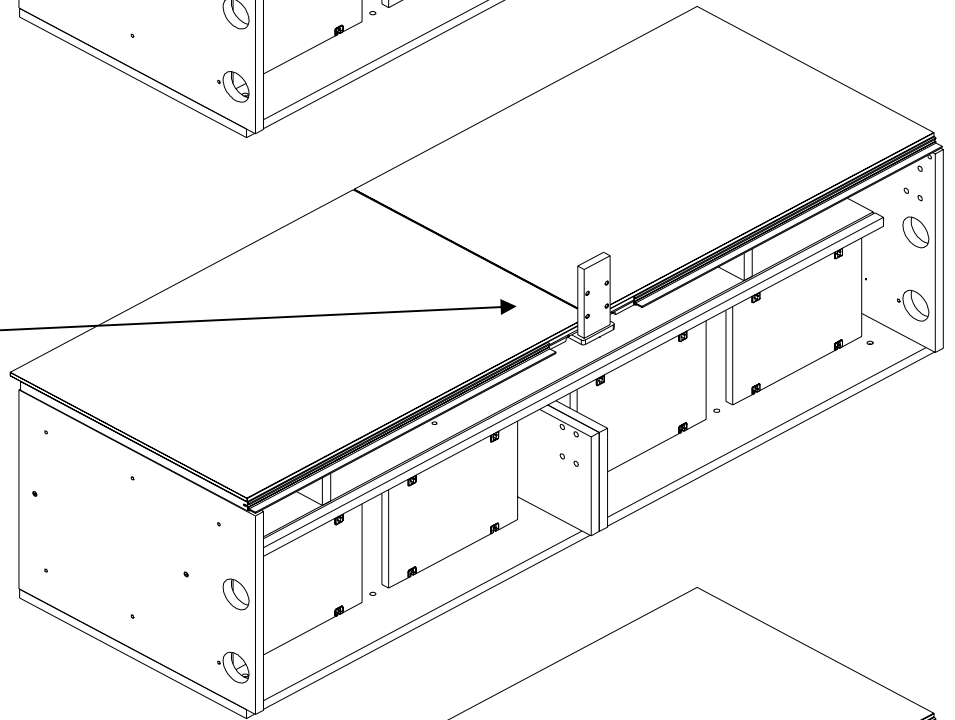
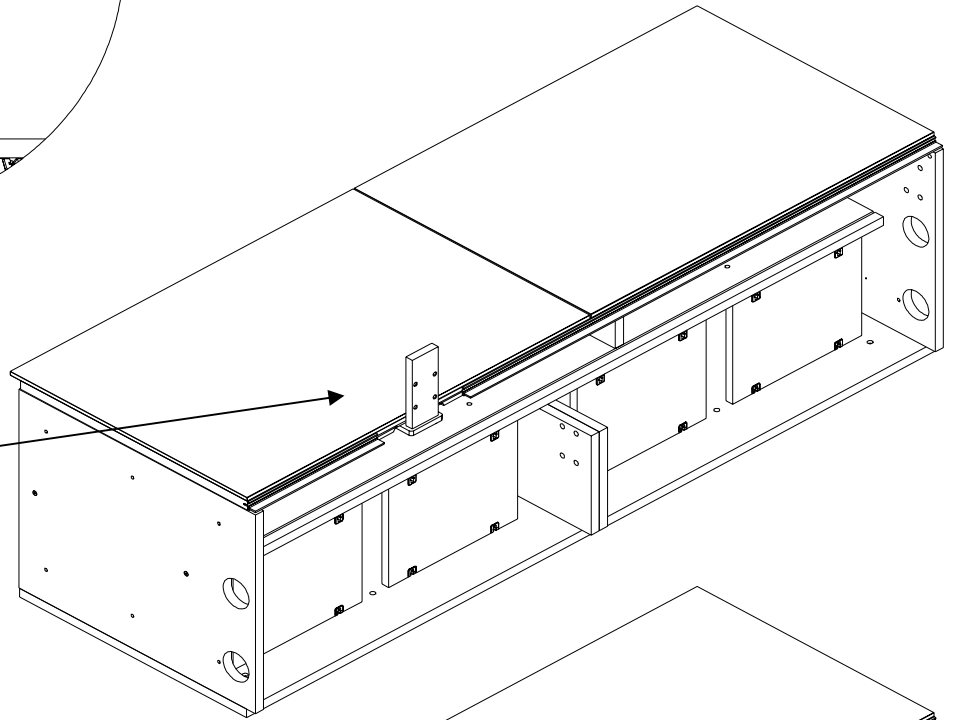

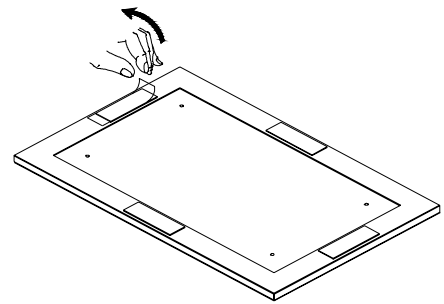
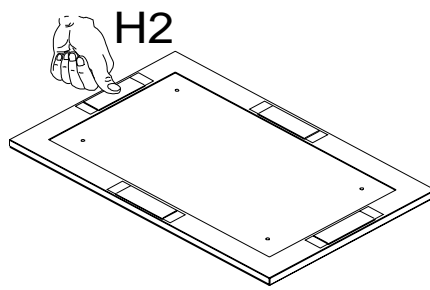
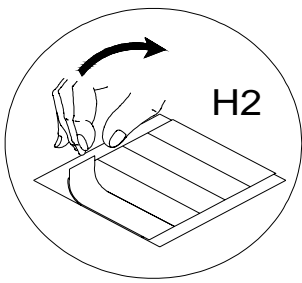

**Die Schrauben zur Befestigung  
der Rückwand nur mit einem  
Handschaubendreher anziehen.  
Keinen Elektro- oder Akkuschauber  
verwenden.**

**Only use a hand screwdriver  
to attach the screws .  
Do not use an electric or  
cordless screwdriver.**

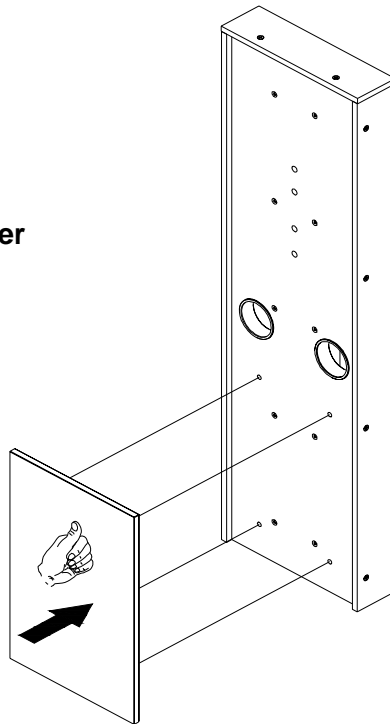

**Typ 192:**

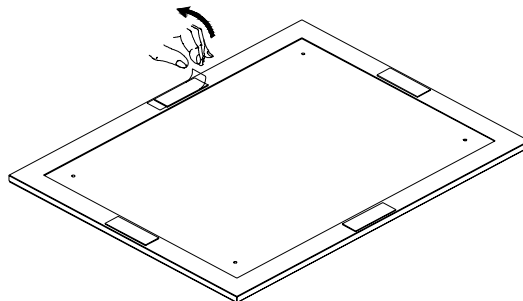
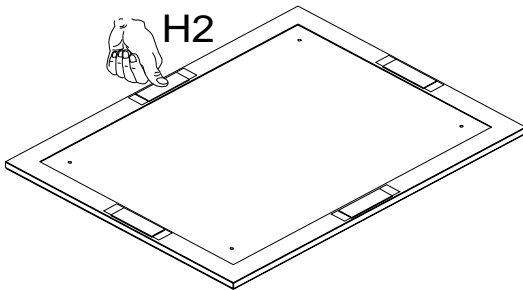
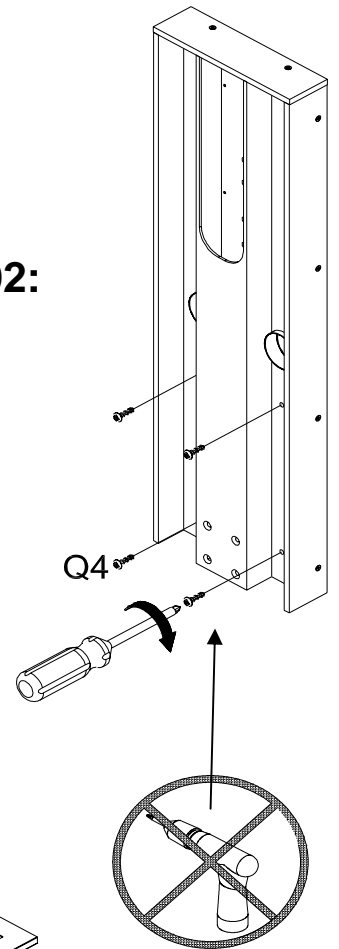

**Typ 194:**

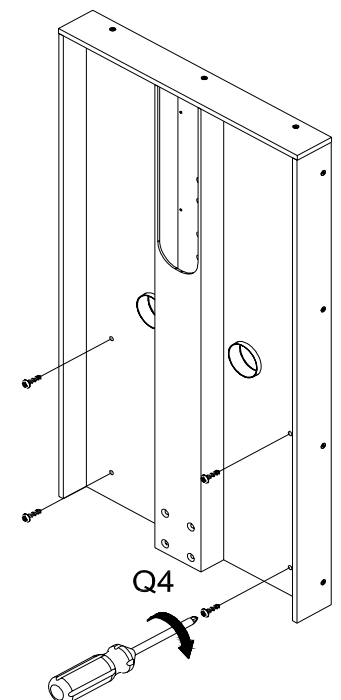
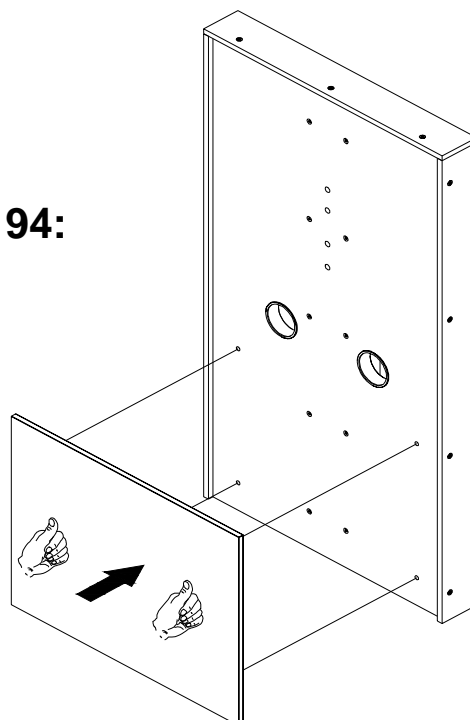



# Typ 192 + 194:

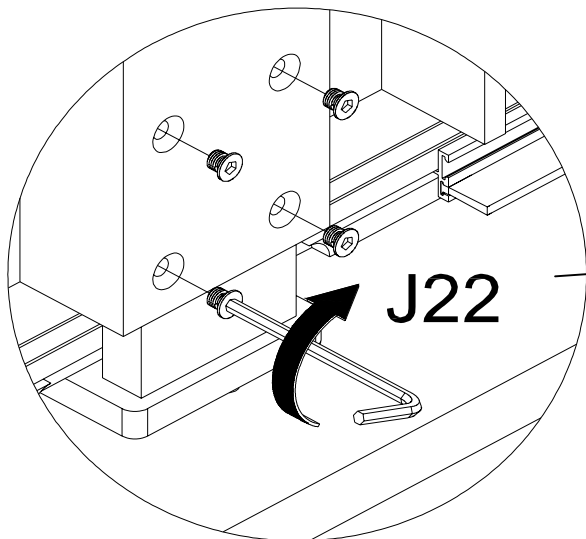
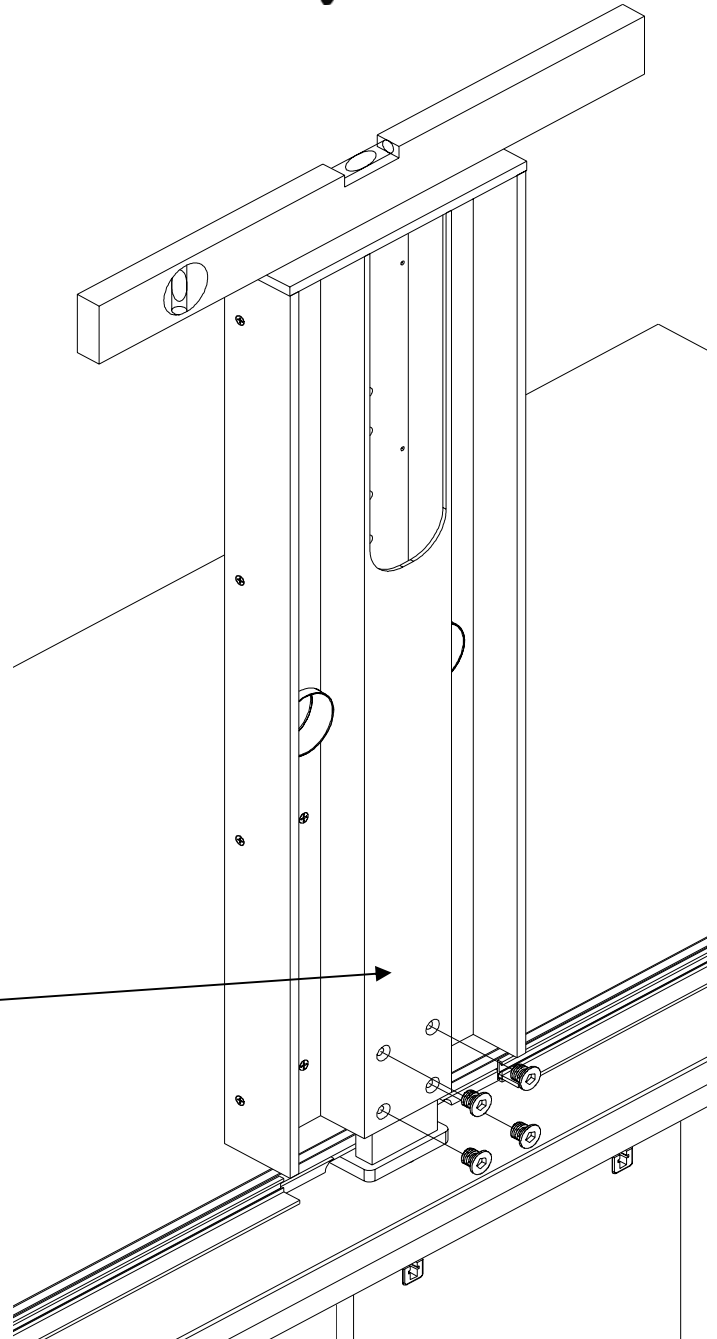
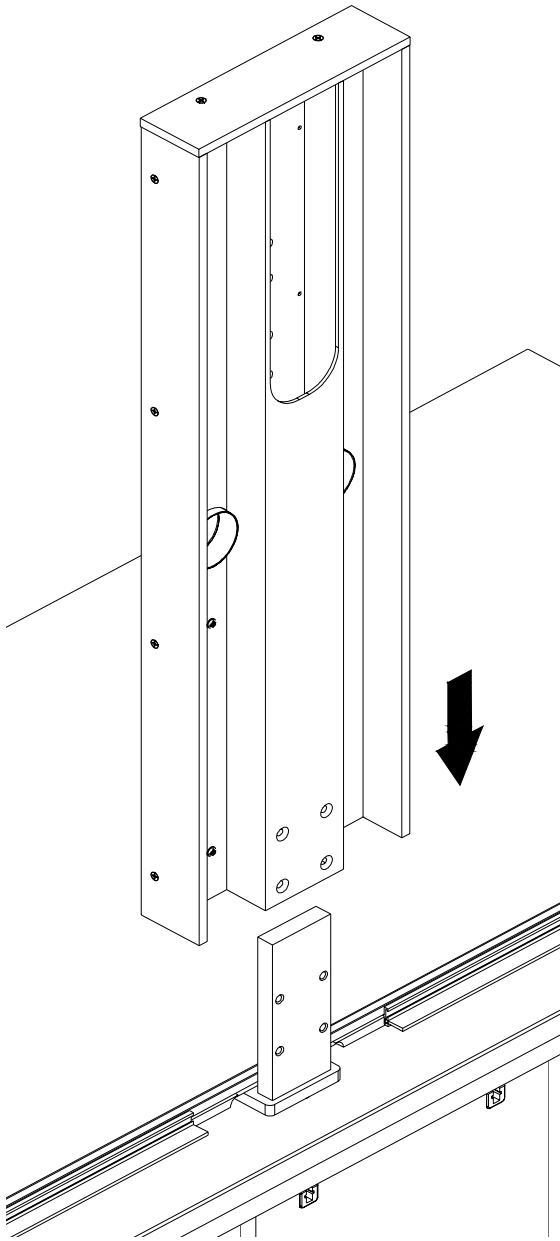
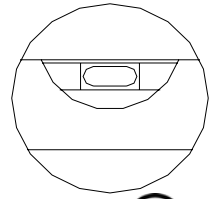
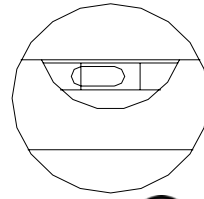
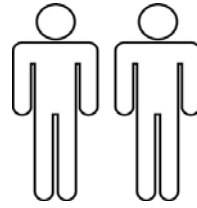



# Beleuchtung optional !

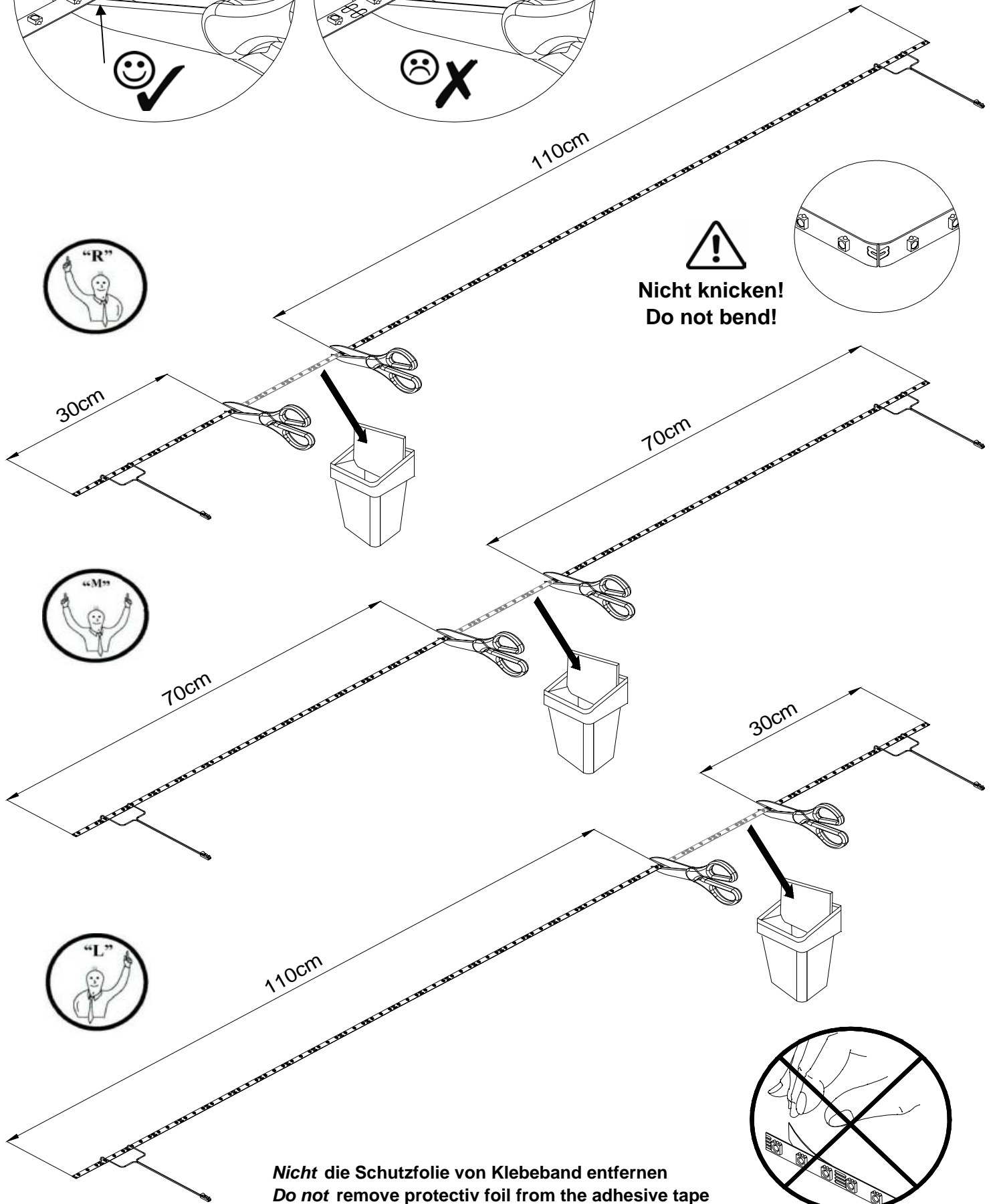
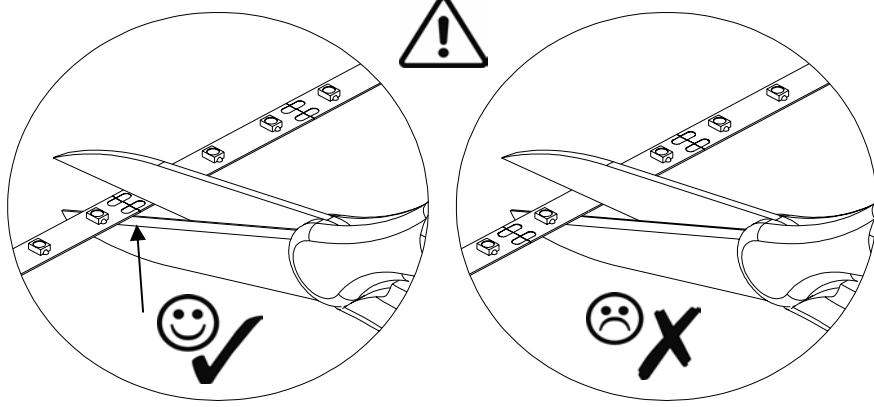

**Nicht die Schutzfolie von Klebeband entfernen  
Do not remove protectiv foil from the adhesive tape**

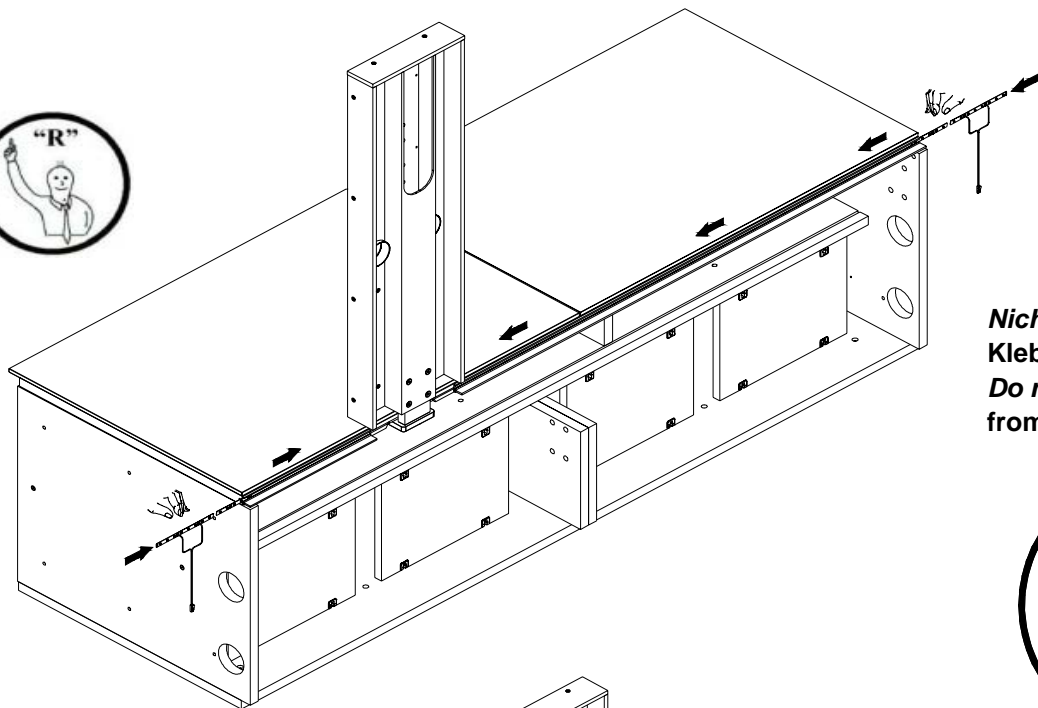

**Nicht die Schutzfolie von  
Kleband entfernen  
Do not remove protectiv foil  
from the adhesive tape**

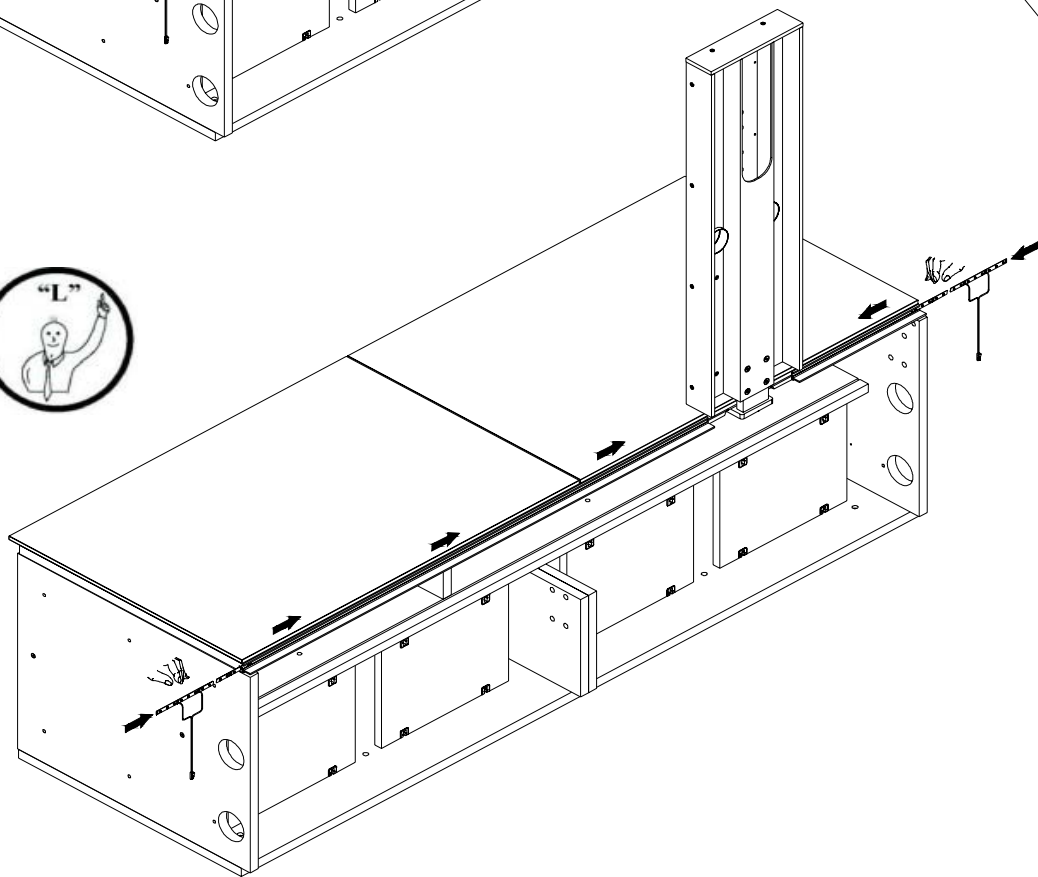
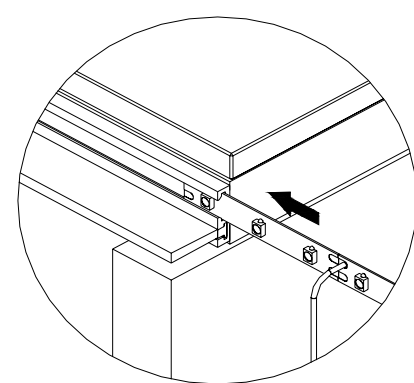
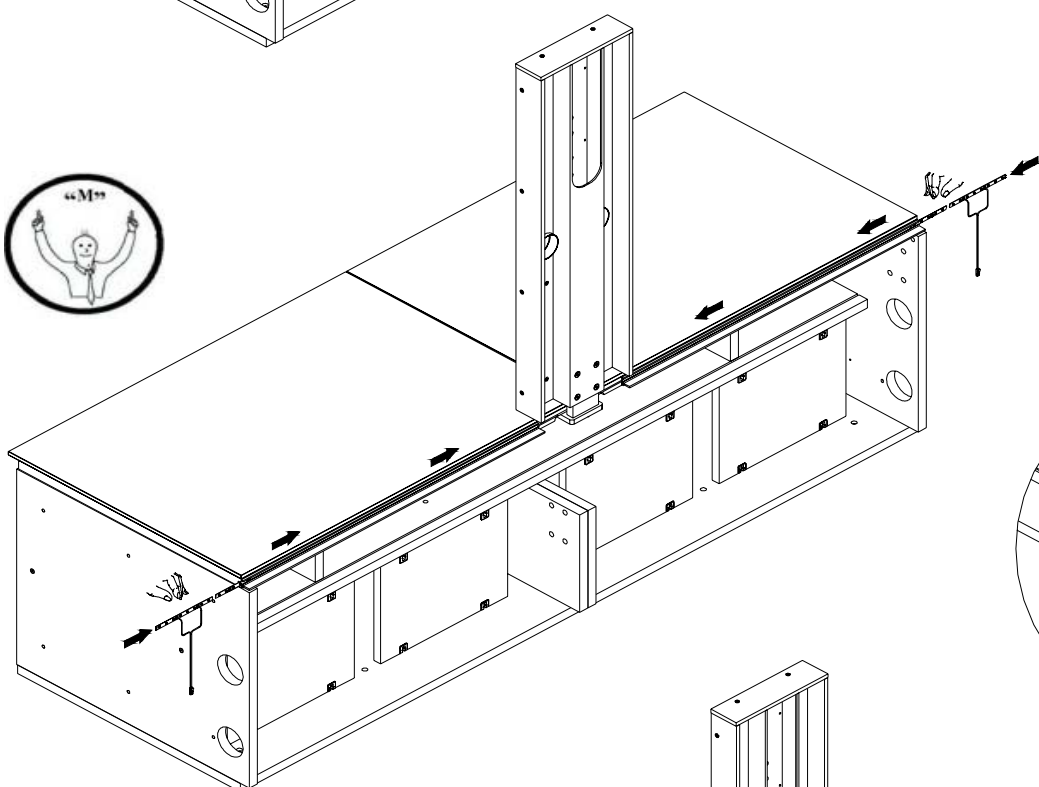
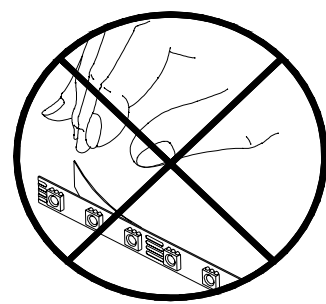

**Nicht knicken!  
Do not bend!**

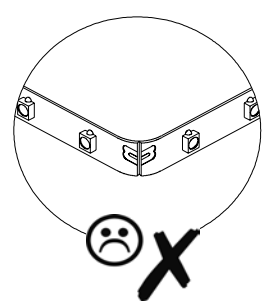

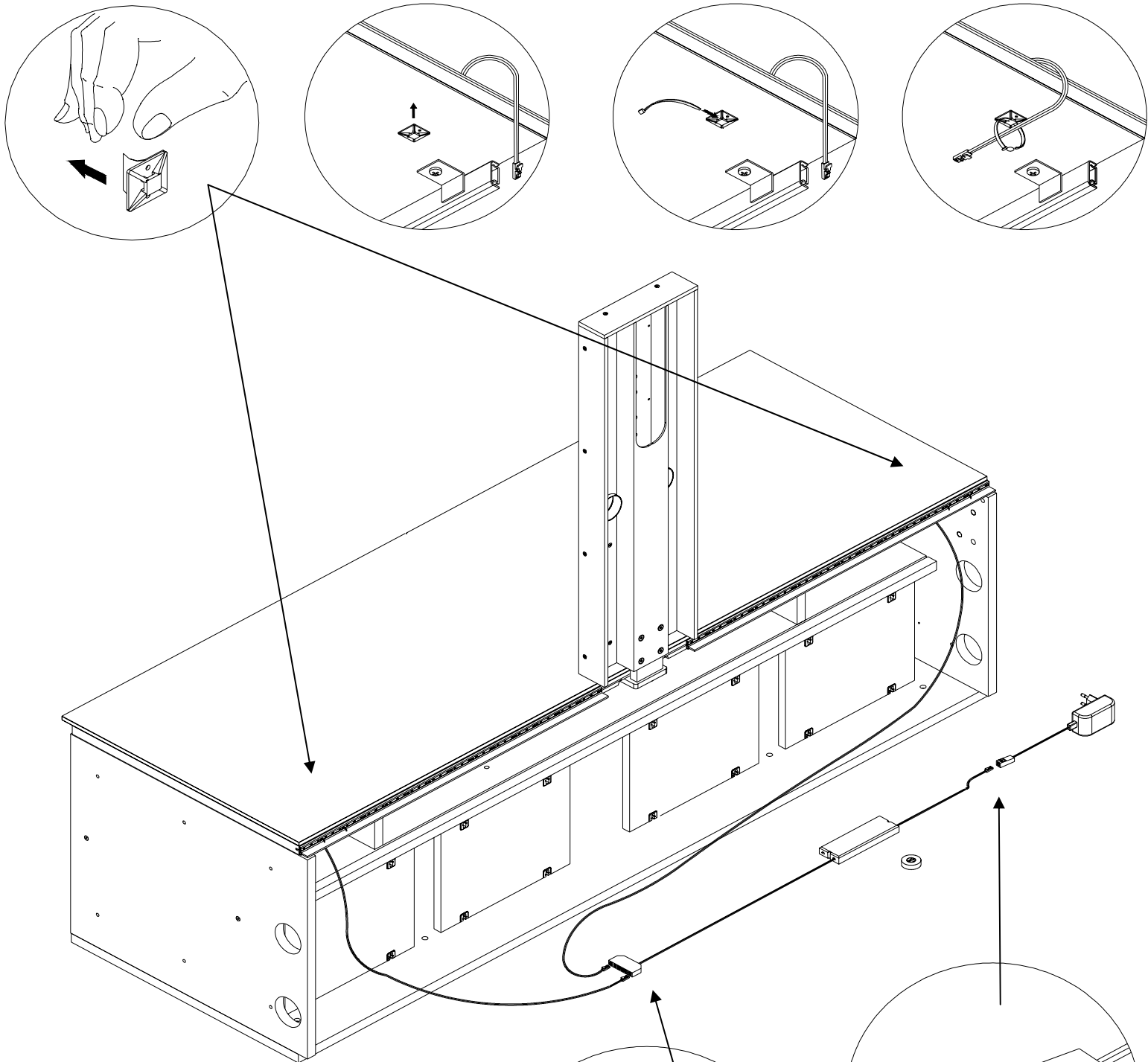

**1. Schutzfolie der Batterie entfernen  
=> Inbetriebnahme !**

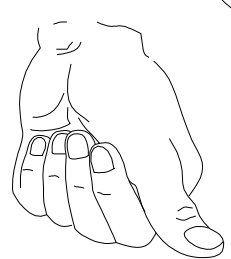
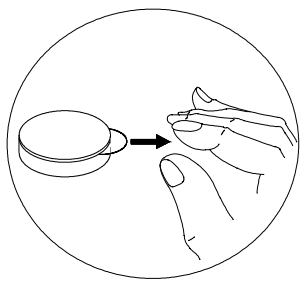
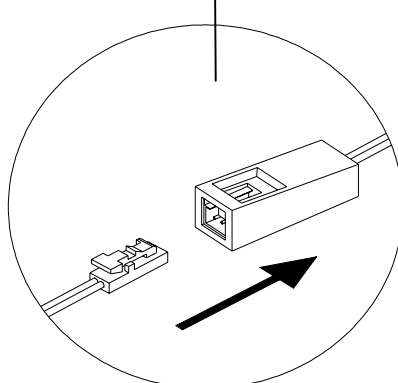
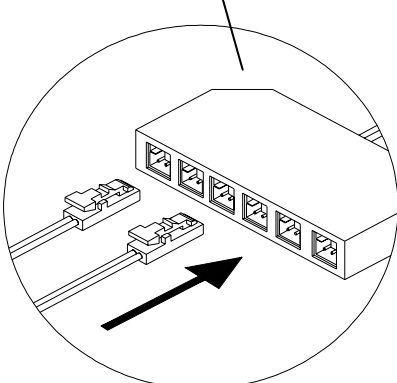

**2.: Kurzer Druck : An / Aus  
Short press: On / Off**

**3.: Langer Druck: Dimmer heller / dunkler  
Long press: Up / Down dimming**

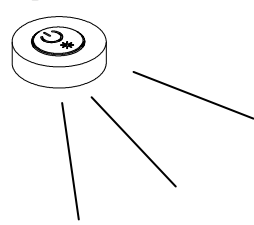

# Aufhängung optional !

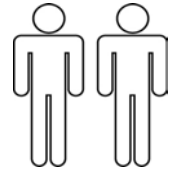
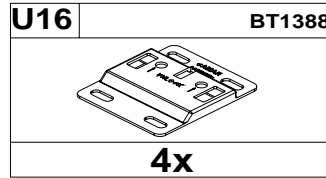
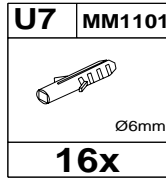
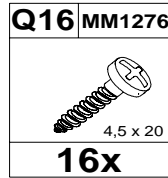
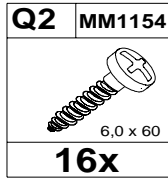
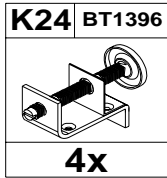

Sehr geehrte Kundin, sehr geehrter Kunde,

Das beigegefügte Wandbefestigungsmaterial (Dübel und Schrauben) eignet sich nur für festes Mauerwerk (z.B. Beton- oder Ziegelwände). Für andere Wandaufbauten sind eventuell Spezialdübel und andere Schrauben notwendig. Ziehen Sie gegebenenfalls eine Fachkraft zurate. Technische Änderungen vorbehalten.

Dear customer,

the provided mounting material (dowels and screws) can only be used with solid masonry (e.g. concrete or brick walls). For other wall constructions special dowels and screws are needed. Please consider an expert in these cases.

Leaving technical changes.

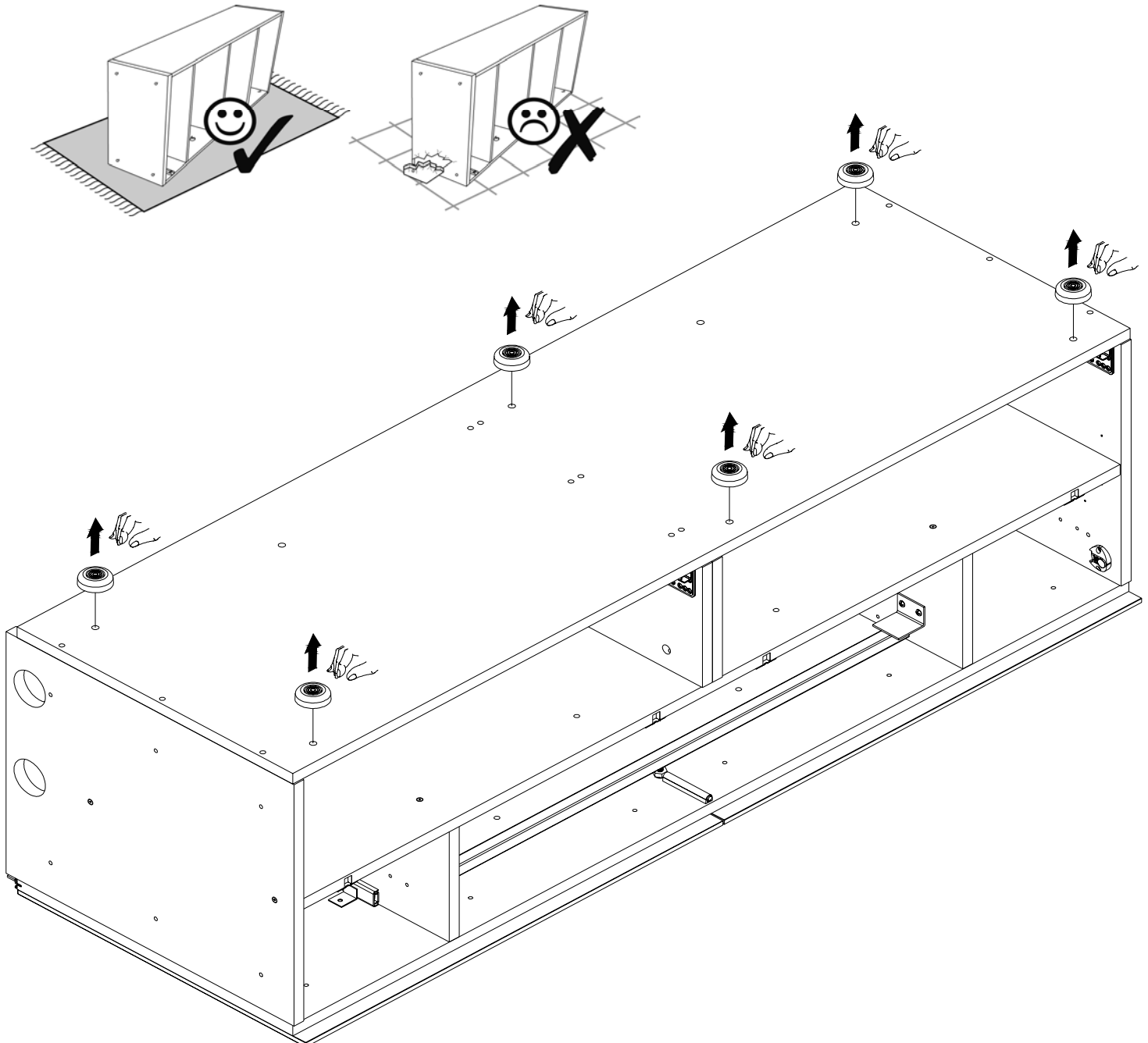

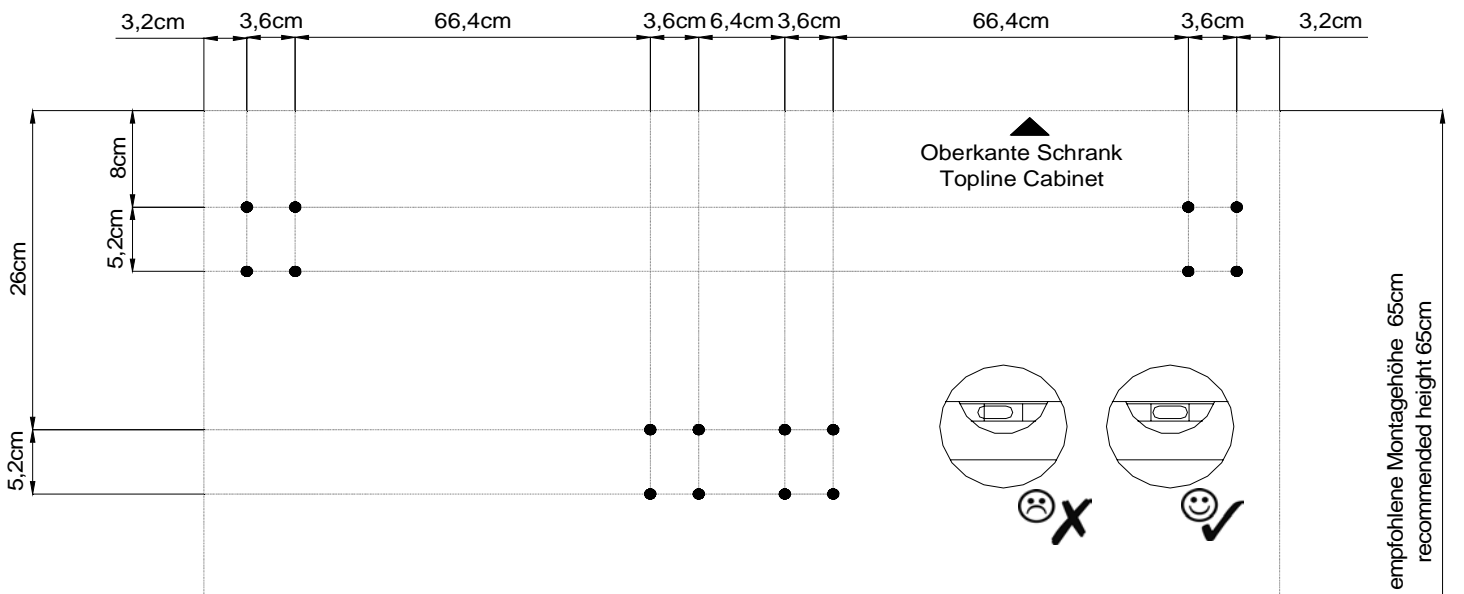
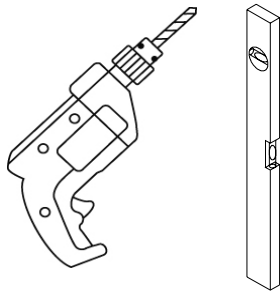
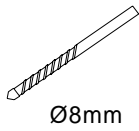
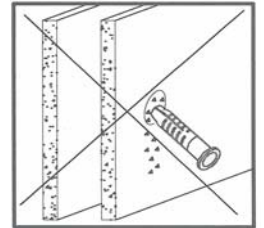
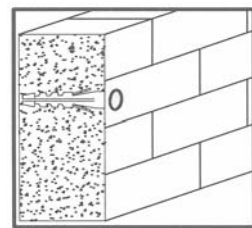
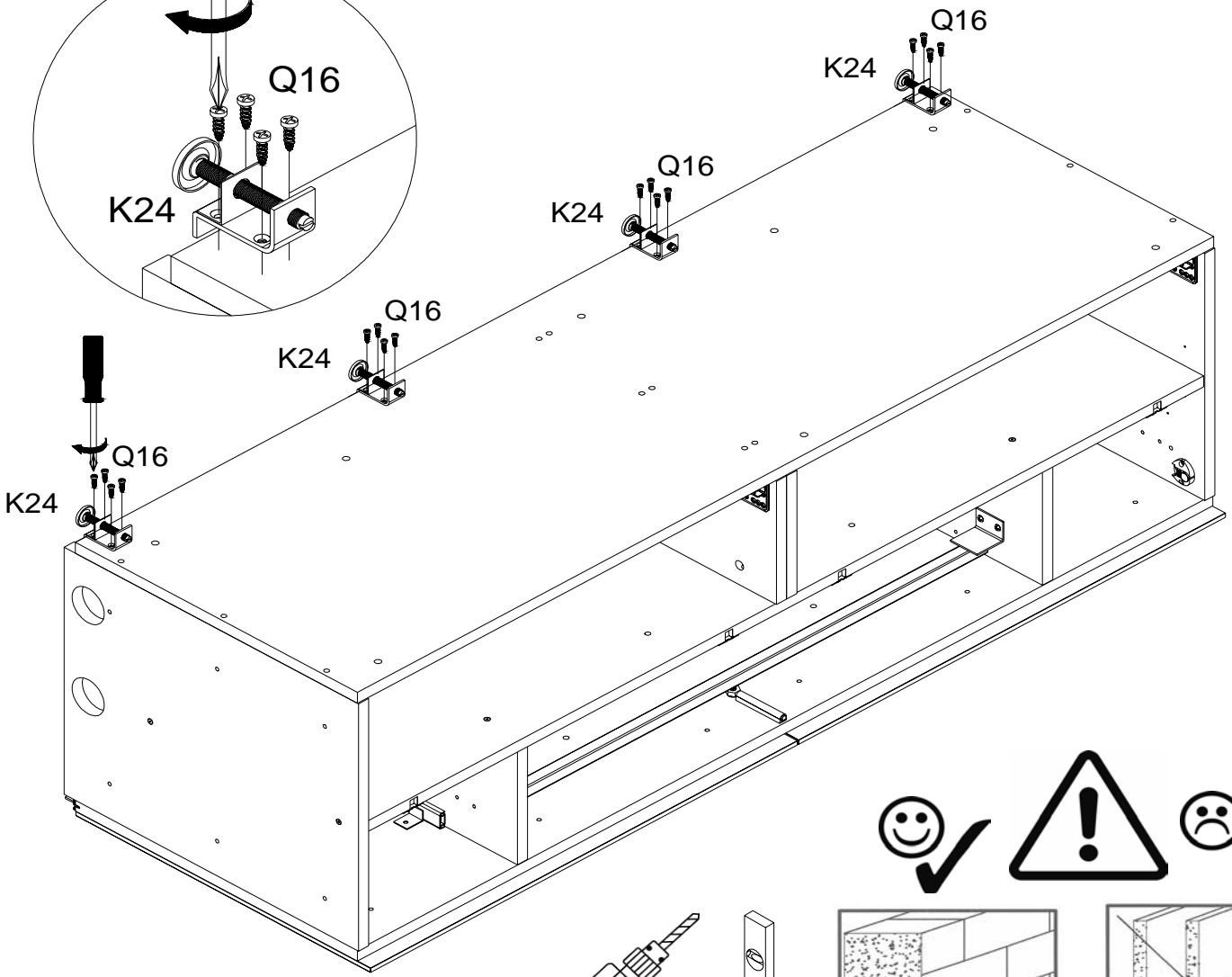
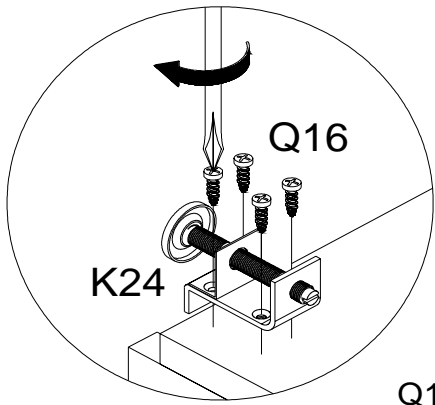

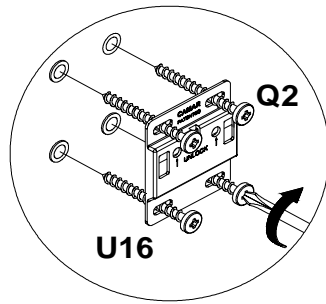
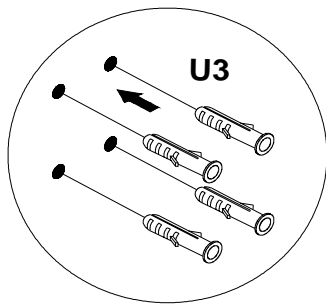

156cm

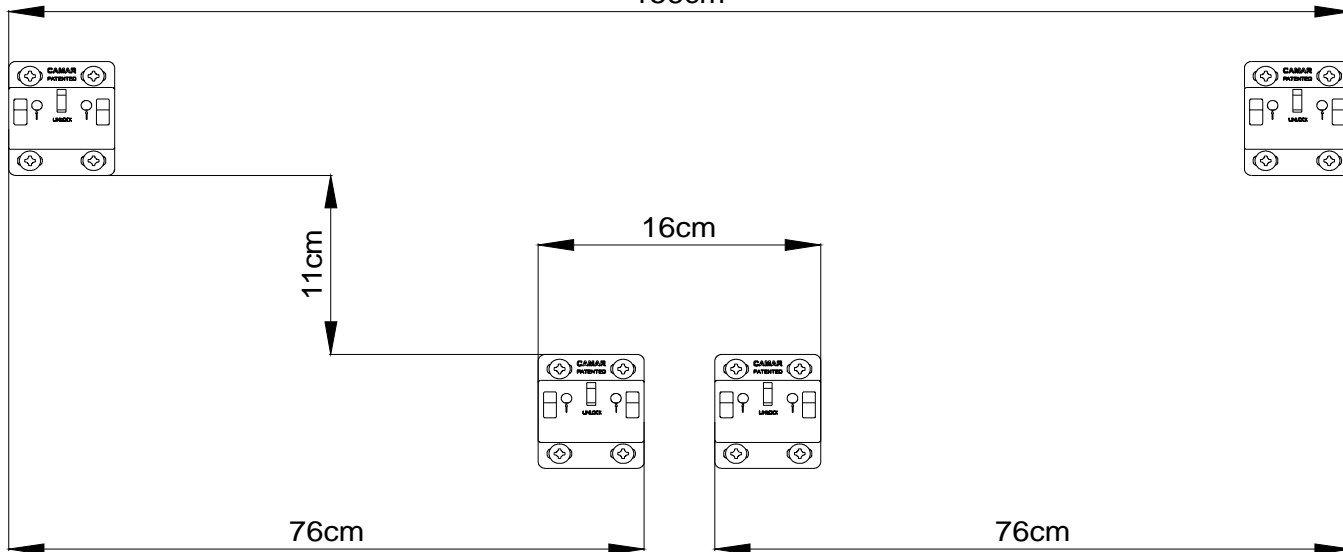

**Montage:  
Assembly:**

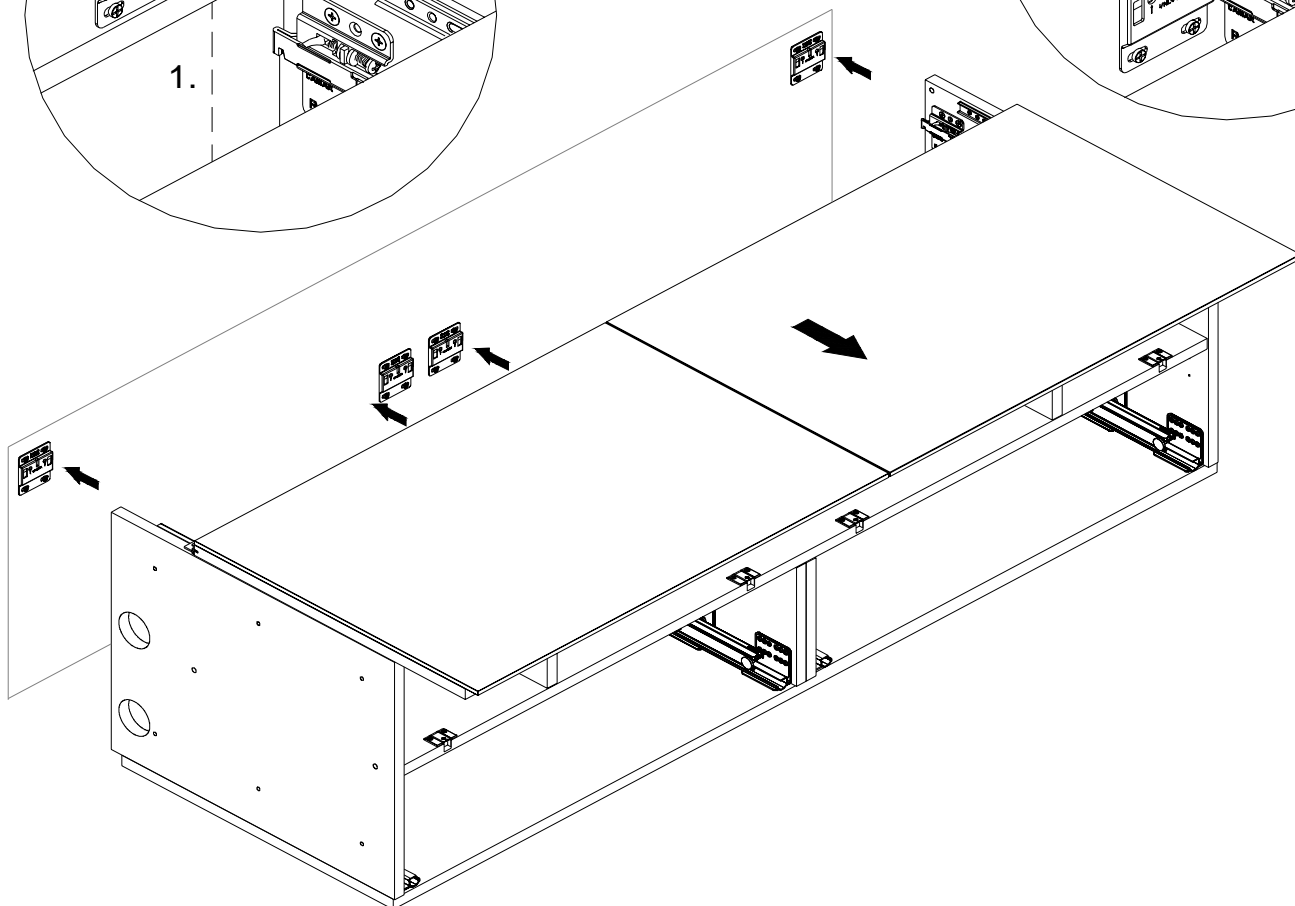
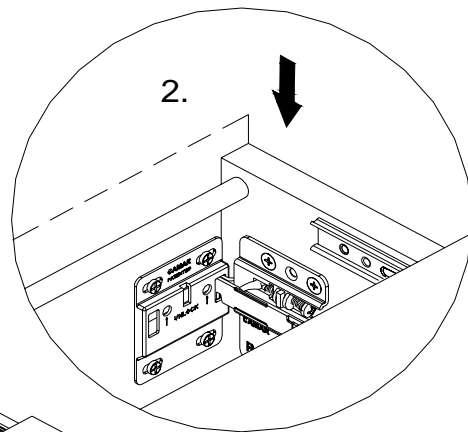
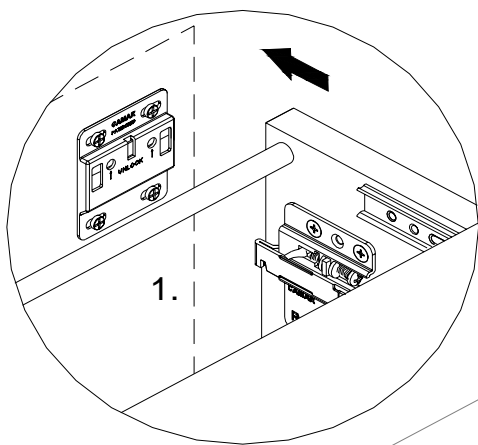
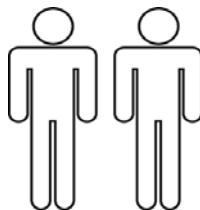

**Ausrichtung:  
Adjustment:**

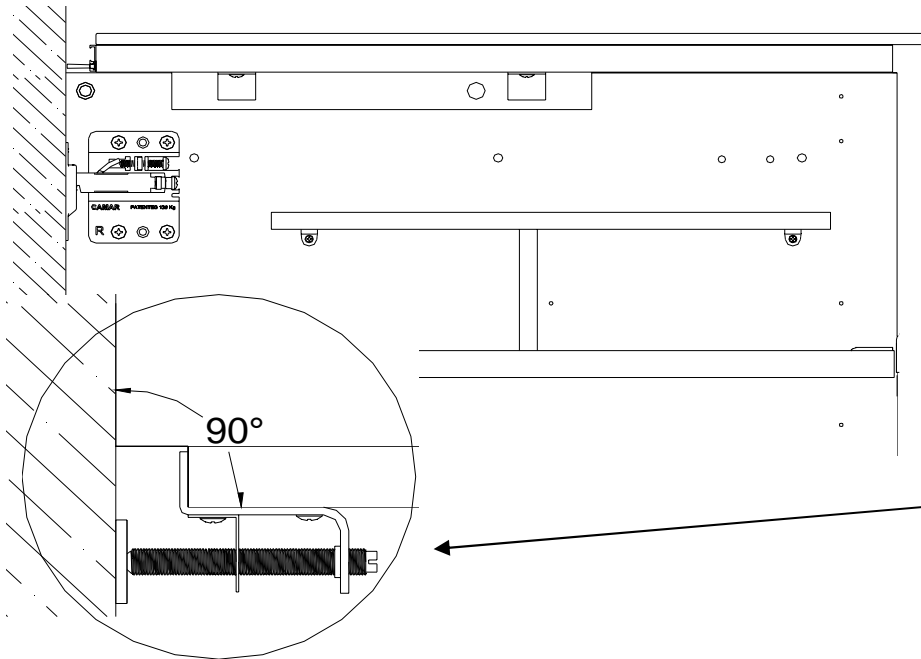
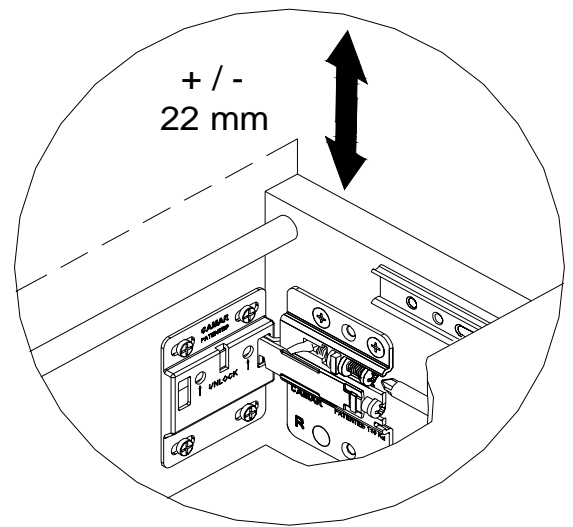
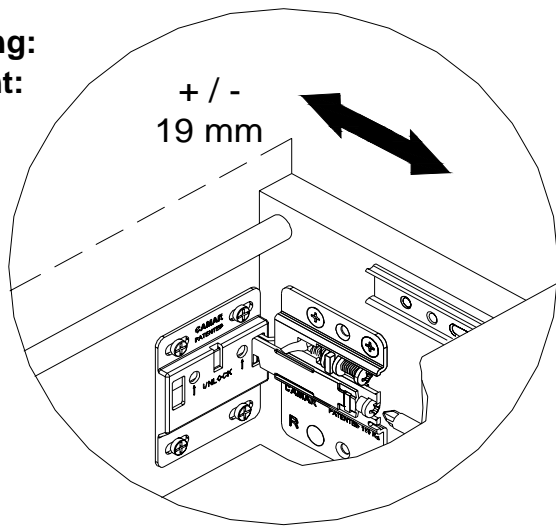

**Ausrichten des Hängeschrankes  
durch die Stellschrauben am  
Aufhängebeschlag:  
Adjustment of the wall cupboard  
with set-screws on the fitting:**

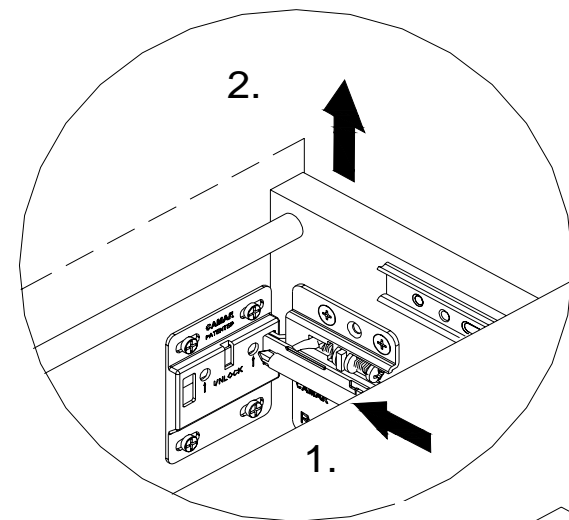

**Demontage:  
Dismounting:**

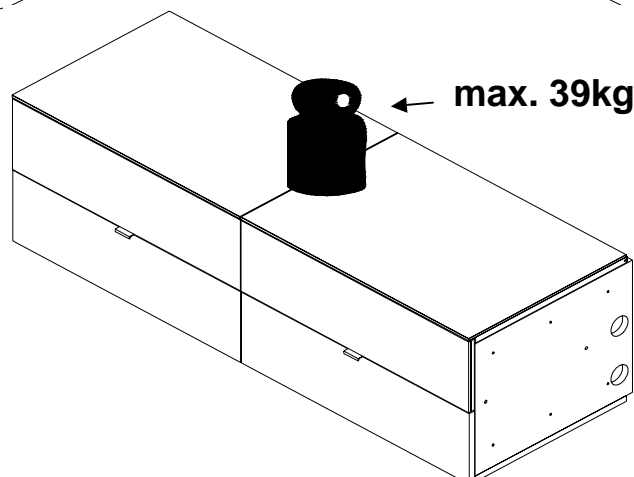
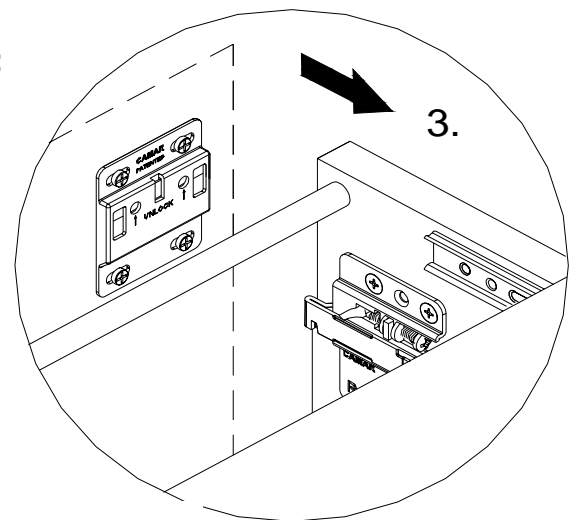
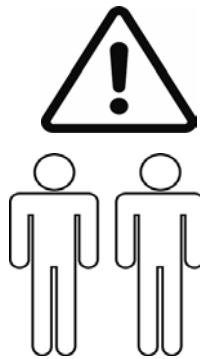

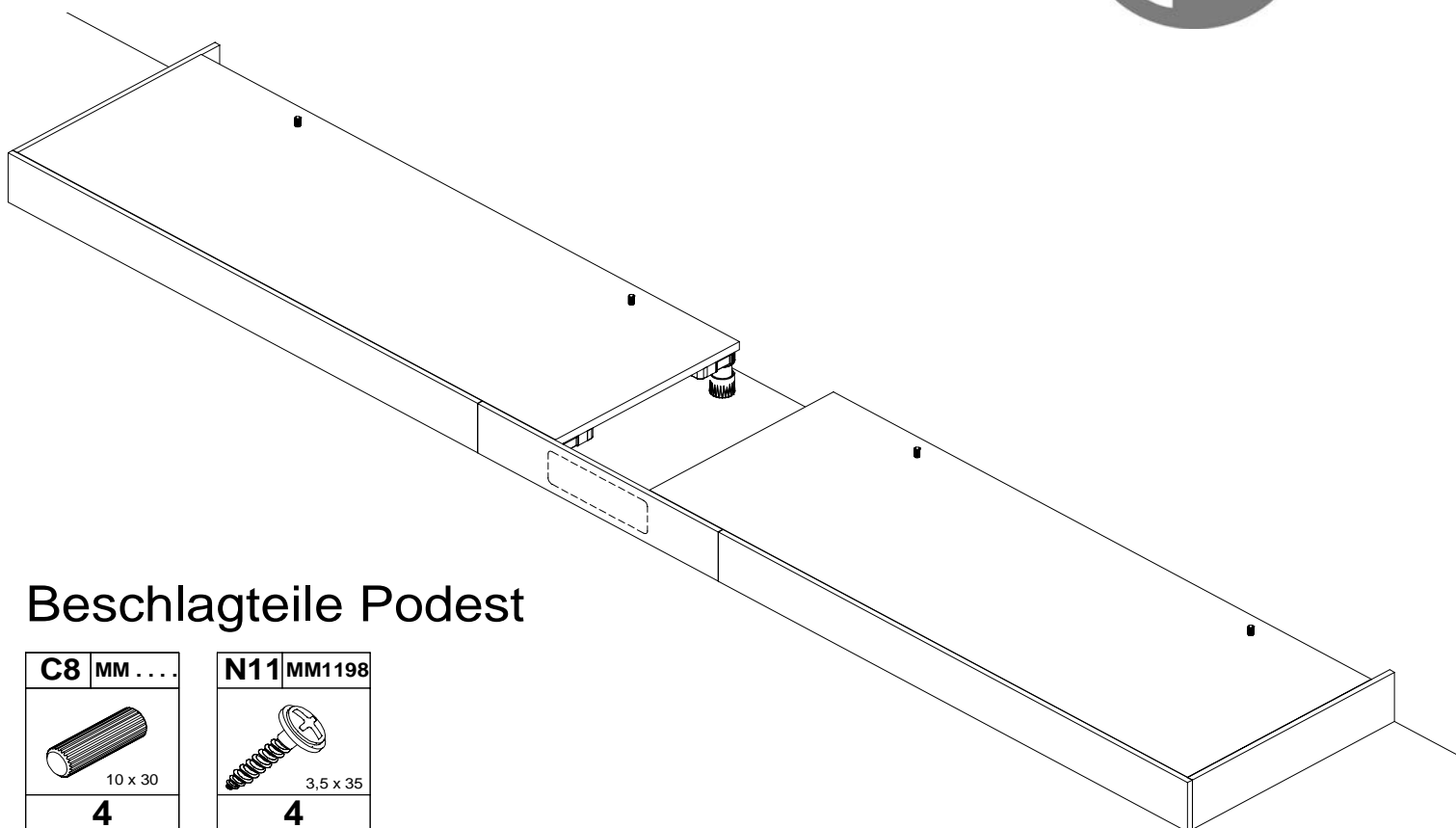

### Beschlagteile Podest

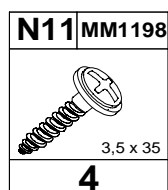
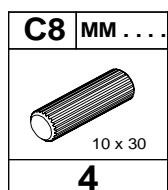

Beschlag / Fitting / Montaža / Felszerelés / Montaj / Vybavení / Vybavenie /  
Ugradnja / Фитинги / Uydurma / Adattamento:

