

980549

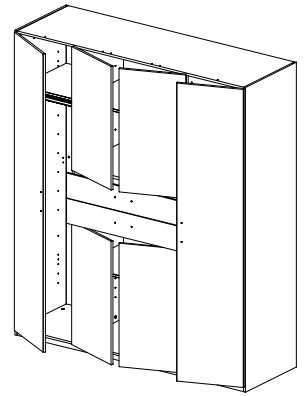

NSP 4tr. 180

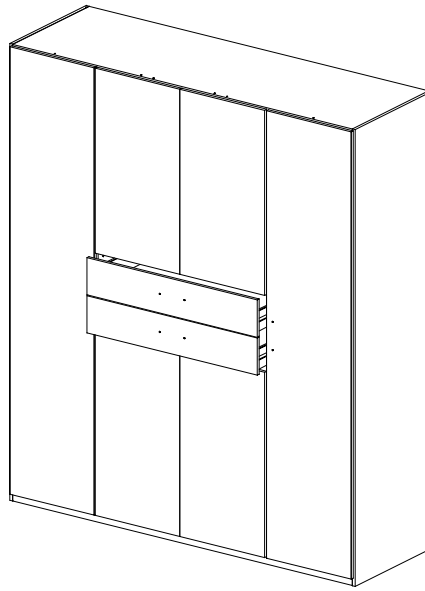
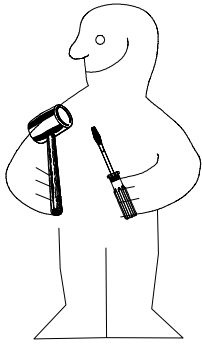
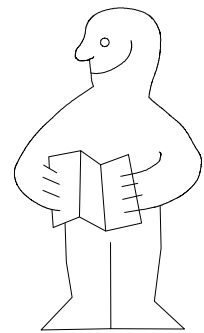
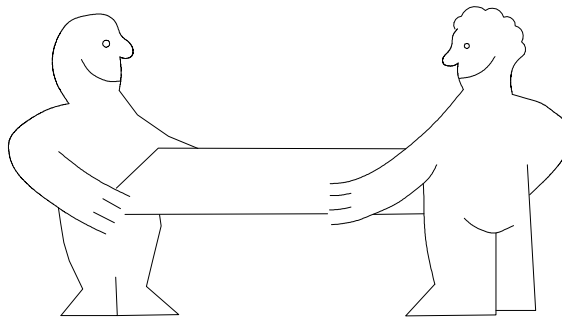
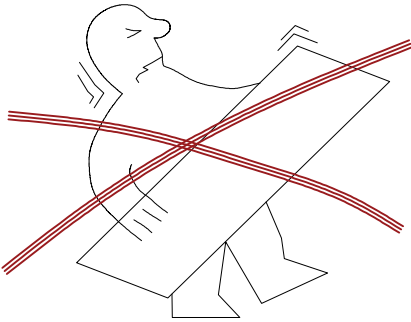

1-2-3-4... ○ ○

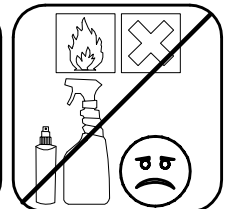
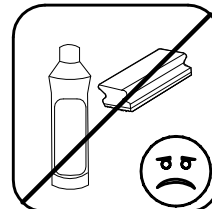
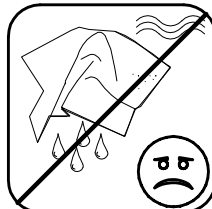
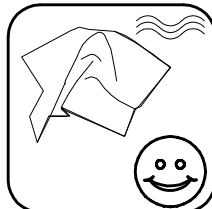
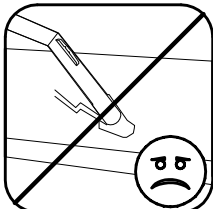
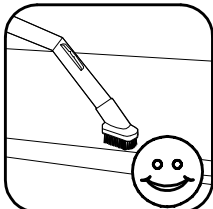
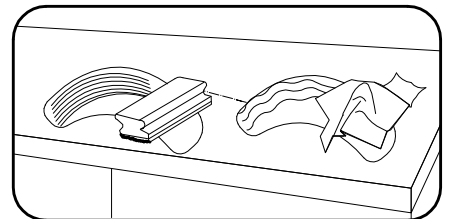
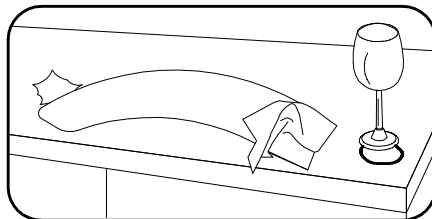
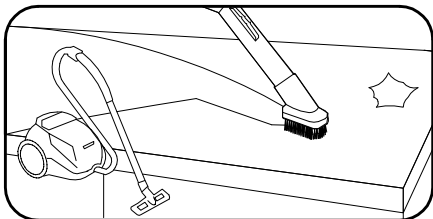
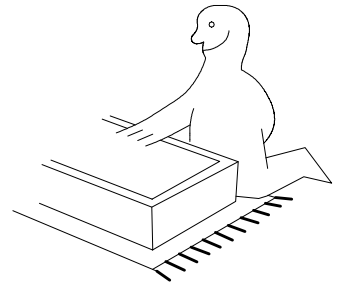
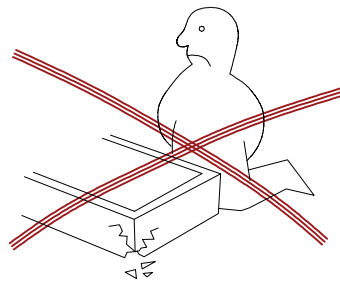
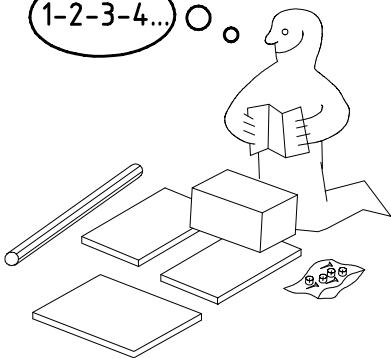

980549

16.06.25 / 04.12.25

12 25

01/29

LTU - LIETUVIŲ ĮSPĖJIMAS - SAUGOS PASTABA

Netinkamai sumontuoti arba ne pagal paskirtį naudojami baldai gali kelti pavojų gyvybei. Norint išvengti šio pavojaus ir sumažinti susižalojimo riziką, būtina laikytis toliau pateiktų saugos nurodymų:

- Baldus turi surinkti kvalifikuoti darbuotojai pagal surinkimo instrukcijas. Negalima per daug priveržti varžtų. Surinkimo metu vaikai turi būti atokiai.
- Visos pakuočės turi būti atidarytos ir perskaitytos visos surinkimo instrukcijos bei saugos nurodymai. Šie dokumentai turi būti laikomi saugioje vietoje. Montuojant galima naudoti tik originalias dalis.
- Baldai su pridėtamais sieniniais tvirtinimo elementais turi būti pritvirtinti prie sienos. Būtina laikytis pridėdamų saugos instrukcijų dėl tvirtinimo prie sienos.
- Baldai kelia pavojų vaikams: todėl pasipūpinkite, kad vaikai neliptų į stalčius ir kitas jų dalis, nesikeltų į juos ir nesikabinėtų ant jų.
- Baldai tinka toliau nurodytoms didžiausioms apkrovoms: lovos (vienam čiužiniui): 100 kg, komoda: 110 kg, nakminių stalukų ir komodų stalviršiai: 15 kg, stiklinės lentynos: 1 kg, sieninės plokštės: (priklausomai nuo tipo), stalčiai: 5 kg, įmontuotos lentynos: 10 kg, drabužių bėgeliai: 40 kg, sieninės spintelės: 20 kg, drabužių keltuvas: 10 kg, lovos stalčiai: 10 kg.

MLT - MALTI TWISSJA - AVVIŻ TAS-SIGURTA

Għamara li mhix immuntata sew jew uzata għall-iskop mħsub tagħha tista 'tkun ta' theddida għall-ħajja. Għalhekk, l-Istruzzjonijiet tas-sigurtà li ġejjin għandhom jiġu osservati:

- L-għamara għandha tkun immuntata minn persunal kwalifikat bl-użu tal-istruzzjonijiet tal-assemblaġġ. Il-viti m'għandhomx jiġu ssikkati żżejjed. Il-fal għandhom jinżammu 'l bogħod waqt l-assemblaġġ.
- Il-pakketti kollha għandhom jinfetxu u l-istruzzjonijiet kollha tal-assemblaġġ u l-istruzzjonijiet tas-sigurtà jinqraw. Dawn id-dokumenti għandhom jinżammu. Partijiet originali biss huma permessi għall-assemblaġġ.
- Għamara b'immuntar fuq il-ħajt inkluz għandha titwaħħal mal-ħajt. L-istruzzjonijiet tas-sigurtà magħluqa għall-immuntar mal-ħajt għandhom jiġu osservati.
- L-għamara tohloq perikli għat-fal: Jekk jogħġbok kun żgur li t-fal ma jilgħux fil-kwaxen jew partijiet oħra, jiġbudu lilhom infushom jew iddendnu magħhom.
- L-għamara hija adattata għat-tagħbijiet massimi li ġejjin: Sodod (għal kull topper tas-saqqu): 100 kg, sedli tal-dresser: 110 kg, komodini u aċċessorji tal-dresser: 15 kg, xkafef tal-ħġieġ: 1 kg, pannelli tal-ħajt: skont it-tip, kwaxen: 5 kg, xkafef inkorporati: 10 kg, linj tal-hwejjeġ: 40 kg, għamara tal-ħajt: 20 kg, lift tal-hwejjeġ: 10 kg, kwaxen tas-sodda: 10 kg.

ROU - ROMÂN AVERTIZARE - NOTĂ DE SIGURANȚĂ

Mobilier care nu este asamblatã corect sau care nu este utilizatã conform destinației poate pune viața în pericol. Prin urmare, trebuie respectate urmãtoarele instrucțiuni de siguranțã:

- Mobilier trebuie asamblatã de personal calificat folosind instrucțiunile de asamblare. Șuruburile nu trebuie strãnse prea tare. Copiii trebuie ținuți departe în timpul asamblãrii.
- Toate ambalajele trebuie deschise și trebuie citite toate instrucțiunile de asamblare și instrucțiunile de siguranțã. Aceste documente trebuie pãstrate într-un loc sigur. Pentru asamblare pot fi utilizate numai piese originale.
- Mobilierul cu elemente de fixare pe perete include trebuie sã fie fixat pe perete. Trebuie respectate instrucțiunile de siguranțã anexate pentru montarea pe perete.
- Mobilier ascunde pericole pentru copii: prin urmare, asigurați-vã cã copii nu se urcã în sertare sau pe alte părți, nu se trag în sus sau nu se așãzã de ele.
- Mobilierul este adecvat pentru urmãtoarele sarcini maxime: Paturi (per topper saltea): 100 kg; 100 kg; comodã: 110 kg; blaturi pentru noptierã și comodã: 15 kg; rafturi din sticlã: 1 kg, panouri de perete: în funcție de tip, serlare: 5 kg, rafturi încorporate: 10 kg, bare pentru haine: 40 kg, unitãți de perete: 20 kg, ridicãtor de haine: 10 kg, sertare de pat: 10 kg.

SWE - SVENSKA VARNING - SÄKERHETSMEDELANDE

Möbler som inte är korrekt monterade eller som inte används på avsett sätt kan vara livsfarliga. För att undvika denna fara och minska risken för skador är det viktigt att följa följande säkerhetsanvisningar:

- Möblerna måste monteras av kvalificerad personal enligt monteringsanvisningarna. Skruvarna får inte dras åt för hårt. Barn ska hållas borta under monteringen.
- Alla förpackningar måste öppnas och alla monteringsanvisningar och säkerhetsanvisningar måste läsas. Dessa dokument måste förvaras på ett säkert ställe. Endast originaldelar får användas vid monteringen.
- Möbler med medföljande väggfästen måste fästas i väggen. Beakta bilogade säkerhetsanvisningar för väggmontering.
- Möbler innebär faror för barn: Se därför till att barn inte klättrar in i lådor eller på andra delar och inte heller drar sig upp eller hänger i dem.
- Möblerna är lämpliga för följande maximala belastningar: Sängar (per bäddmadrass): 100 kg, byrå: 110 kg, nattsduksbord och byråskivor: 15 kg, glashyllor: 1 kg, väggpaneler: beroende på typ, lådor: 5 kg, inbyggda hyllor: 40 kg, väggskåp: 20 kg, klädlyft: 10 kg, sänglådor: 10 kg.

GRC - ελληνικά ΠΡΟΕΙΔΟΠΟΙΗΣΗ - ΟΔΗΓΙΕΣ ΑΣΦΑΛΕΙΑΣ

Τα έπιπλα που δεν έχουν συναρμολογηθεί σωστά ή δεν χρησιμοποιούνται όπως προβλέπεται μπορεί να είναι απειλητικά για τη ζωή. Επομένως, πρέπει να τηρούνται οι ακόλουθες οδηγίες ασφαλείας:

- Τα έπιπλα πρέπει να συναρμολογούνται από εξειδικευμένο προσωπικό σύμφωνα με τις οδηγίες συναρμολόγησης. Οι βίδες δεν πρέπει να σφίγγονται υπερβολικά. Τα παιδιά πρέπει να μένουν μακριά κατά τη συναρμολόγηση.
- Όλες οι συσκευασίες πρέπει να είναι ανοιχτές και όλες οι οδηγίες συναρμολόγησης και οι οδηγίες ασφαλείας πρέπει να διαβάζονται και να φυλάσσονται σε ασφαλές μέρος. Για τη συναρμολόγηση επιτρέπεται να χρησιμοποιούνται μόνο γνήσια εξαρτήματα.
- Τα έπιπλα με κλειστά επιτοιχία εξαρτήματα πρέπει να στερεώνονται στον τοίχο. Πρέπει να τηρούνται οι συνημμένες οδηγίες ασφαλείας για την τοποθέτηση στον τοίχο.
- Τα έπιπλα κρβθουν κινδύνους για τα παιδιά: Για το λόγο αυτό, βεβαιωθείτε ότι τα παιδιά δεν σκαρφάλωνουν στα συρτάρια ή σε άλλα μέρη ή δεν τραβιούνται ή κρέμονται από αυτά.
- Τα έπιπλα είναι κατάλληλα για τα ακόλουθα μέγιστα φορτία: Κρεβάτια (ανά επικάλυψη στρώματος): συρτάρια: 110 kg, κομοδίνα και συρτάρια: 15 kg, γυάλινα ράφια: 1 kg, επιτοίχια πάνελ: ανάλογα με τον τύπο, συρτάρια: 5 kg, ενσωματωμένα ράφια: 10 kg, ράγες ρούχων: 40 kg, επιτοίχια έπιπλα: 20 kg, ανυψωτικό ρούχων: 10 kg, συρτάρια κρεβατιού: 10 kg.

IRL - GAELIGE RABHADH - GCEARA SÁBHÁILTEACHTA

Is féidir le troscán nach gcuirtear le chéile i gceart nó nach n-úsáidtear chun na críche atá beartaíte dhó a bheith bagrach don bheatha. Dá bhrí sin, ní mór cloi leis na treoracha sábháilteachta seo a leanas:

- Ní mór do phearsanra cáiliúil an troscán a chur le chéile ag baint úsáide as na treoracha tionóil. Níor cheart scríúna a róthearmh. Ní mór leanáí a choinneáil ar shiúl le linn tionóil.
- Ní mór gach pacáiste a oscailt agus gach treoir tionóil agus treoracha sábháilteachta a léamh. Ní mór na doiciméid seo a choinneáil. Ní cheadaítear ach páirteanna bunaidh a chur le chéile.
- Ní mór troscán le gléasadh balla san áireamh le cheangal leis an mballa. Ní mór cloi leis na treoracha sábháilteachta iniata le haghaidh gléasta balla.
- Tá contúirtí ag baint le troscán do leanáí: Cinntigh le do thoil nach dtógfaidh leanáí isteach i drawers nó páirteanna eile, go dtarraingíonn siad suas iad féin nó nach gcloifidh siad leo.
- Tá an troscán oiriúnach do na huaili uasta seo a leanas: Leapaicha (in aghaidh an topper tochtá): 100 kg, suiocháin gúna: 110 kg, táblaí tal-ghaige ceangaltán gúna: 15 kg, seilfeanna gloine: 1 kg, painéil balla: ag brath ar an gceinéal, tarraiceán: 5 kg, Seilfeanna insuite: 10 kg, ráilí éadaí: 40 kg, troscán balla: 20 kg, ardaitheoir éadaí: 10 kg, tarraiceán leaba: 10kg.

HRV - Hrvatski UPOZORENJE - SIGURNOSNA OBAVIJEST

Namještaj koji nije pravilno sastavljen ili korišten prema namjeni može biti opasan po život. Kako biste izbjegli ovu opasnost i smanjili rizik od ozljeda, važno je pridržavati se sljedećih sigurnosnih uputa:

- Namještaj mora sastaviti kvalificirano osoblje prema uputama za sastavljanje. Vijci se ne smiju previše zategnuti. Az öszeszerezelés során a gyerekeket távol kell tartani.
- Sva pakiranja moraju biti otvorena i pročitanе svе upute za sastavljanje i sigurnosne upute. Ovi dokumenti moraju se čuvati. Za montažu su dopušteni samo originalni dijelovi.
- Namještaj s uključenom montažom na zid mora biti pričvršćen na zid. Morate se pridržavati priloženih sigurnosnih uputa za zidnu montažu.
- Namještaj predstavlja opasnost za djecu: Pazite da se djeca ne penju u ladice ili druge dijelove, da se ne povlače ili vise na njima.
- Namještaj je prikladan za sljedeća maksimalna opterećenja: Kreveti (po nadmadracu): 100 kg, sjedala za komode: 110 kg, noćni ormarići i dodaci za komode: 15 kg, staklene police: 1 kg, zidne ploče: ovisno o vrsti, ladice: 5 kg, ugradbene police: 10 kg, šipke za odjeću: 40 kg, zidni namještaj: 20 kg, podizač odjeće: 10 kg, ladice za krevet: 10 kg.

LVA - Latviešu BRĪDINĀJUMS - DROŠĪBAS INSTRUKCIJAS

Mēbeles, kas nav pareizi samontētas vai netiek lietotas atbilstoši paredzētajam mērķim, var apdraudēt dzīvību. Lai izvairītos no šādām briesmām un samazinātu traumu risku, ir svarīgi ievērot turpmāk minētos drošības norādījumus:

- Mēbeles jāsamontē kvalificētam personālam saskaņā ar montāžas instrukcijām. Skrūves nedrīkst pārspīlēt. Montāžas laikā bērniem jābūt prom.
- Jaatver visi iepakojumi un jālasa visas montāžas instrukcijas un drošības norādījumi. Šie dokumenti jāglabā drošā vietā. Montāžai drīkst izmantot tikai oriģinālās detaļas.
- Mēbeles ar pievienotiem sienas stiprinājumiem jāpiestiprina pie sienas. Jāievēro pievienotie drošības norādījumi par montāžu pie sienas.
- Mēbeles slēpj briesmas bērniem: tāpēc jāpārliecināties, ka bērni neliel atvilktnēs vai uz citām mēbeļu daļām, nevelk uz tām vai karājas uz tām.
- Mēbeles ir piemērotas šādām maksimālajām slodzēm: Gultas (za vien gult matraci): 100 kg, kumodes: 110 kg, naktsskapīšu un kumodes virsma: 15 kg, stikla plaukti: 1 kg, slēnas paneļi: atkarībā no tipa, atvilktnes: 5 kg, iebūvētie plaukti: 10 kg, drēbju pakaramie: 40 kg, sienas skapīši: 20 kg, drēbju pacelājs: 10 kg, gultas atvilktnes: 10 kg.

BGR - Български ПРЕДУПРЕЖДЕНИЕ - ИНСТРУКЦИИ ЗА БЕЗОПАСНОСТ

Мебели, които не саглобени правилно или не се използват по предназначение, могат да бъдат опасни за живота. Следователно трябва да се спазват следните инструкции за безопасност:

- Мебелите трябва да се глобяват от квалифициран персонал в съответствие с инструкциите за глобяване. Винтовете не трябва да се затягат прекалено. Децата трябва да се държат настрана по време на монтажа.
- Всички опаковки трябва да бъдат отворени и всички инструкции за монтаж и безопасност трябва да бъдат прочетени и съхранявани безопасно. За глобяване могат да се използват само оригинални части.
- Мебелите с вградени стени приспособления трябва да бъдат закрепени към стената. Трябва да се спазват приложените инструкции за безопасност при монтаж на стена.
- Мебелите крият опасности за децата: Затова се уверете, че децата не се катерят по чекмеджетата или по други части, не се издърпват или не висят от тях.
- Мебелите са подходящи за следните максимални натоварвания: легла (за един гол матрак): 100 кг, скрин: 110 кг, плотове за нощни шкафчета и скрин: 15 кг, стъклените рафтове: 1 кг, стени панели: в зависимост от вида, чекмеджета: 5 кг, вградени рафтове: 10 кг, релси за дрехи: 40 кг, стени шкафове: 20 кг, подемник за дрехи: 10 кг, чекмеджета за легла: 10 кг.

DNK - Dansk ADVARSEL - SIKKERHEDSINSTRUKTIONER

Møbler, der ikke er samlet korrekt eller ikke anvendes efter hensigten, kan være livsfarlige. For at undgå denne fare og reducere risikoen for skader skal følgende sikkerhedsanvisninger overholdes:

- Møblerne skal samles af kvalificeret personale i overensstemmelse med monteringsvejledningen. Skruer må ikke overspændes. Børn skal holdes væk under montering.
- Alle pakker skal åbnes, og alle monteringsanvisninger og sikkerhedsanvisninger skal læses. Disse dokumenter skal opbevares på et sikkert sted. Der må kun bruges originale dele til monteringen.
- Møbler med vedlagte vægbeslag skal fastgøres til væggen. De vedlagte sikkerhedsanvisninger for vægmontering skal overholdes.
- Møbler nummer farer for børn: Sørg derfor for, at børn ikke kravler ind i skuffer eller på andre dele eller trækker sig op eller hænger i dem.
- Møblerne er egnede til følgende maksimale belastninger: Senge (pr. topmadræs): 100 kg, kommode: 110 kg, natbords- og kommodeplader: 15 kg, glashylder: 1 kg, vægpaneler: afhængigt af type, skuffer: 5 kg, indbyggede hylder: 10 kg, bøjlestænger: 40 kg, overskabe: 20 kg, tøjlift: 10 kg, sengeskuffer: 10 kg.

EST - Eesti HOIATUS - OHUTUSJUHISED

Korrektselt kokku panemata või mitte ettenähtud viisil kasutatav mööbel võib olla eluohtlik. Selle ohu vältimiseks ja vigastusohu vähendamiseks on oluline järgida järgmisi ohutusjuhiseid:

- Mööbilit peavad monteerima kvalifitseeritud töötajad vastavalt monteerimisjuhendile. Kruvisid ei tohi üle pingutada. Lapsed tuleb kokkupaneku ajal eemal hoida.
- Kõik pakendid tuleb avada ning lugeda kõiki koostamisjuhiseid ja ohutusjuhiseid. Neid dokumente tuleb hoida turvalises kohas. Kokkupanekuks tohib kasutada ainult originaalosi.
- Kinnitatud seinakinnitustega mööbel tuleb kinnitada seina külge. Tuleb järgida lisatud ohutusjuhiseid seinakinnituse kohta.
- Mööbel katkeb endas ohte lastele: seepärast veenduge, et lapsed ei ronil sahtlitesse või muudesse osadesse, ei tõmba end üles ega ripu nende külge.
- Mööbel sobib järgmistele maksimaalsetele koormustele jaoks: Voodid (ühe madratsitopere kohta): 100 kg, kapp: 110 kg, öökappide ja kappide laudad: 15 kg, klaasriiulid: 1 kg, seinapaneelid: sõltuvalt tüübist, sahtlid: 5 kg, sisseehitatud riidid: 10 kg, riederiulid: 40 kg, seinapaneelid: 20 kg, riidelifti: 10 kg, voodisahtlid: 10 kg.

FIN - suomalaisen VAROITUS - TURVALLISUUSOHJEET



Huonekalut, joita ei ole koottu oikein tai joita ei käytetä tarkoitellulla tavalla, voivat olla hengenvaarallisia. Tämän vaaran välttämiseksi ja loukkaantumisriskin vähentämiseksi on noudatettava seuraavia turvallisuusohjeita:





- Pätevän henkilöstön on koottava kalusteet kokoonpano-ohjeiden mukaisesti. Ruuveja ei saa kiristää liikaa. Lapsen on pidettävä loitolla kokoamisen aikana.
- Kaikki pakkaukset on avattava ja kaikki kokoonpano- ja turvallisuusohjeet on luettava. Nämä asiakirjat on säilytettävä turvallisessa paikassa. Kokoonpanossa saa käyttää vain alkuperäisiä osia.
- Huonekalut, joissa on mukana seinäkiinnikkeet, on kiinnitettävä seinään. Oheisia seinäkiinnitystä koskevia turvallisuusohjeita on noudatettava.
- Huonekaluihin liittyv vaarallisia lauseita: Varmista siksi, että lapset eivät kinnelä laatikoihin tai muihin osiin eivätkä vedä itseään völe tai miin pöytä.

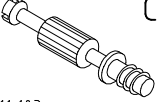
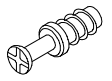

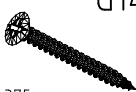

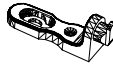

980549

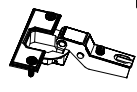
16.06.25 / 04.12.25

12 25 03/29

 111 102	A	16x
 111 103	C	16x
 111 229 3,5 x 15 mm	F	4x
 121 370 M4 x 9 mm	G1	10x
 111 015 3,5x35 mm	G8	4x
 121 375	G14	8x

 111 174	J1	6x
 117 001	K1	4x
 112 403 4,22mm	K44	2x
 111 610	L7	16x
 112 268	M	14x
 112 267	N	14x

 111 143	SBV	4x
 112 616 6,3 x 10	T3	8x
 121 181 6,3x11	T6	6x
 111 252	VB23	4x
 112 190	Y20	4x
 163 007	Z	2x

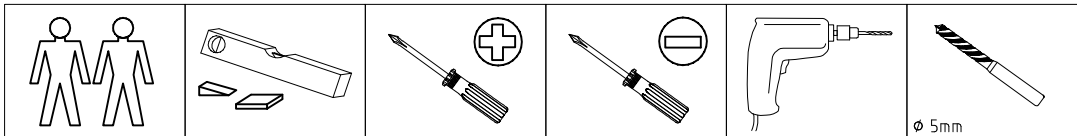
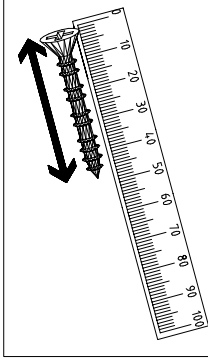
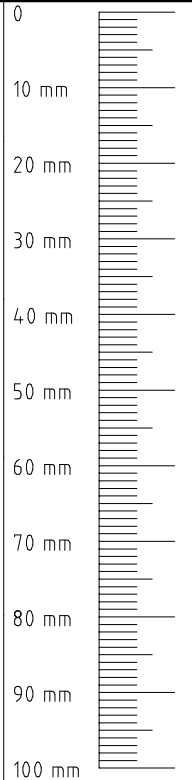

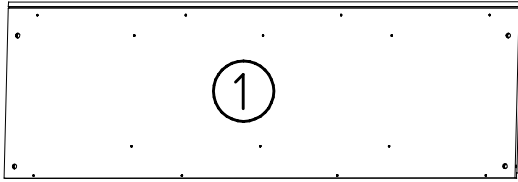

1761x560x15

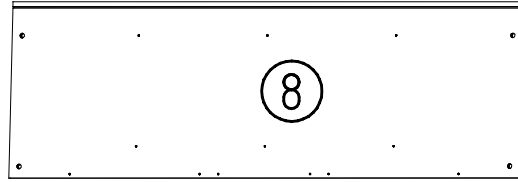

1761x560x15

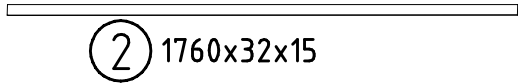

2 1760x32x15

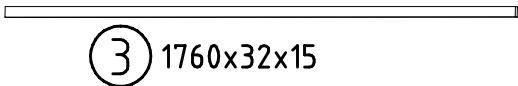

3 1760x32x15

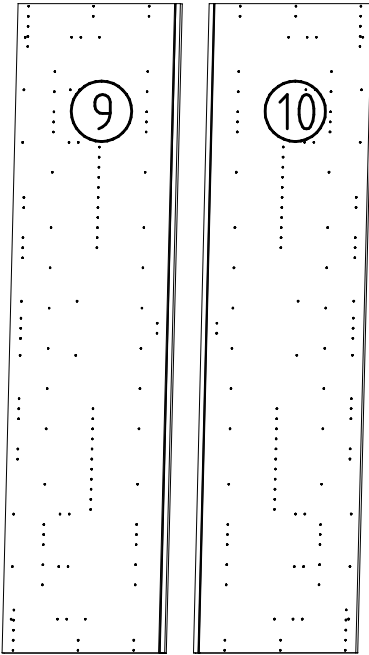

2064x560x15

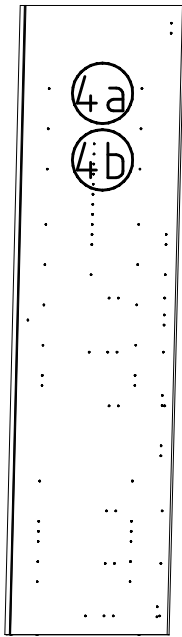

2001x560x15

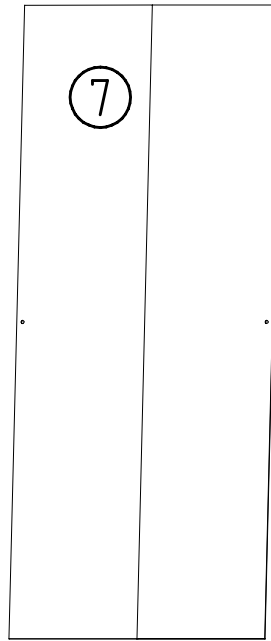

2015x882x2,5

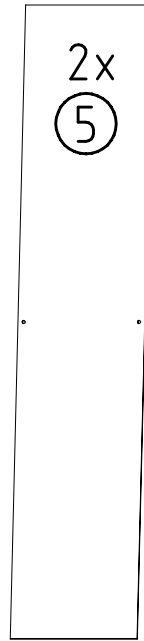

2015x882x2,5

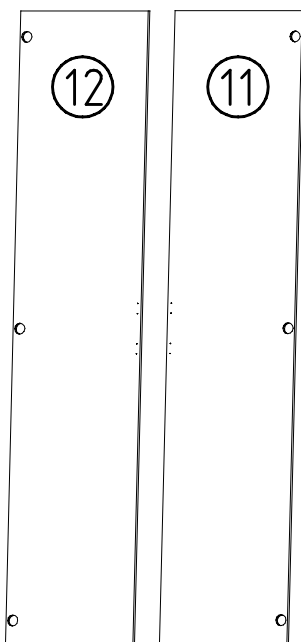

2021x439x15

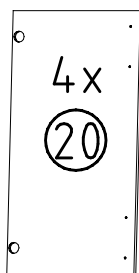

837x439x15

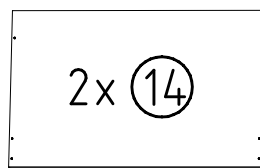

837x500x18

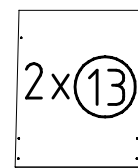

429x500x18

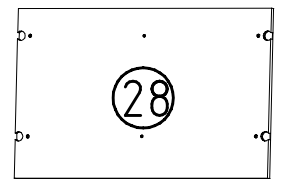

837x540x18

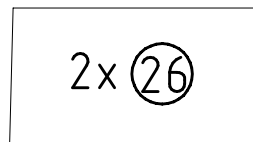

852x439x2,5

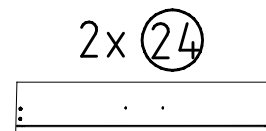

883x168x15

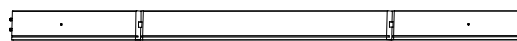

2x 25 439/866/439x92x12,5

1

3,5x35 mm

G14

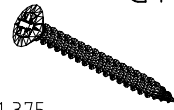

121 375

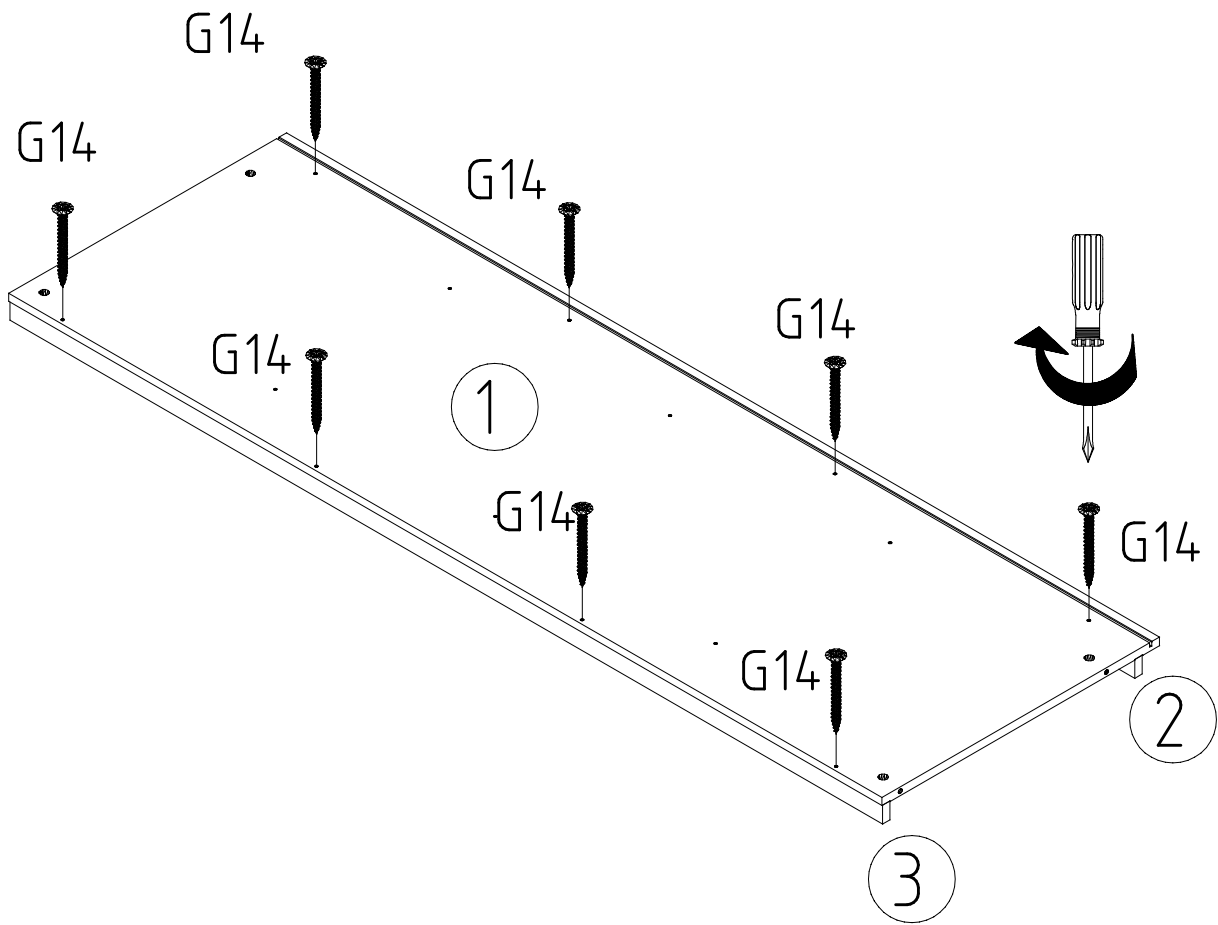
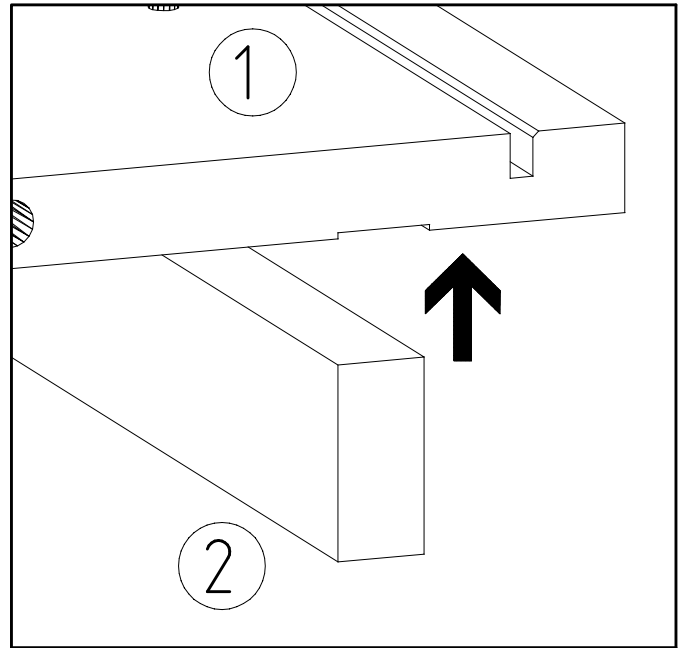
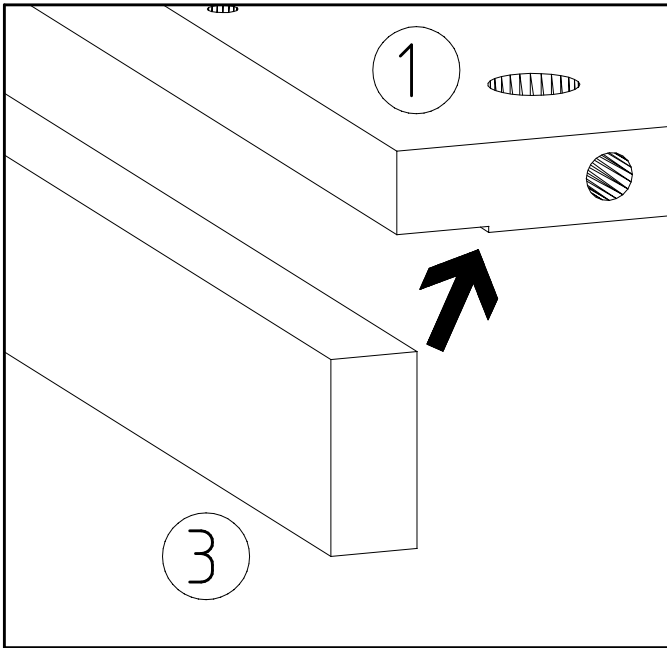
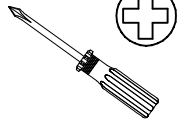

2

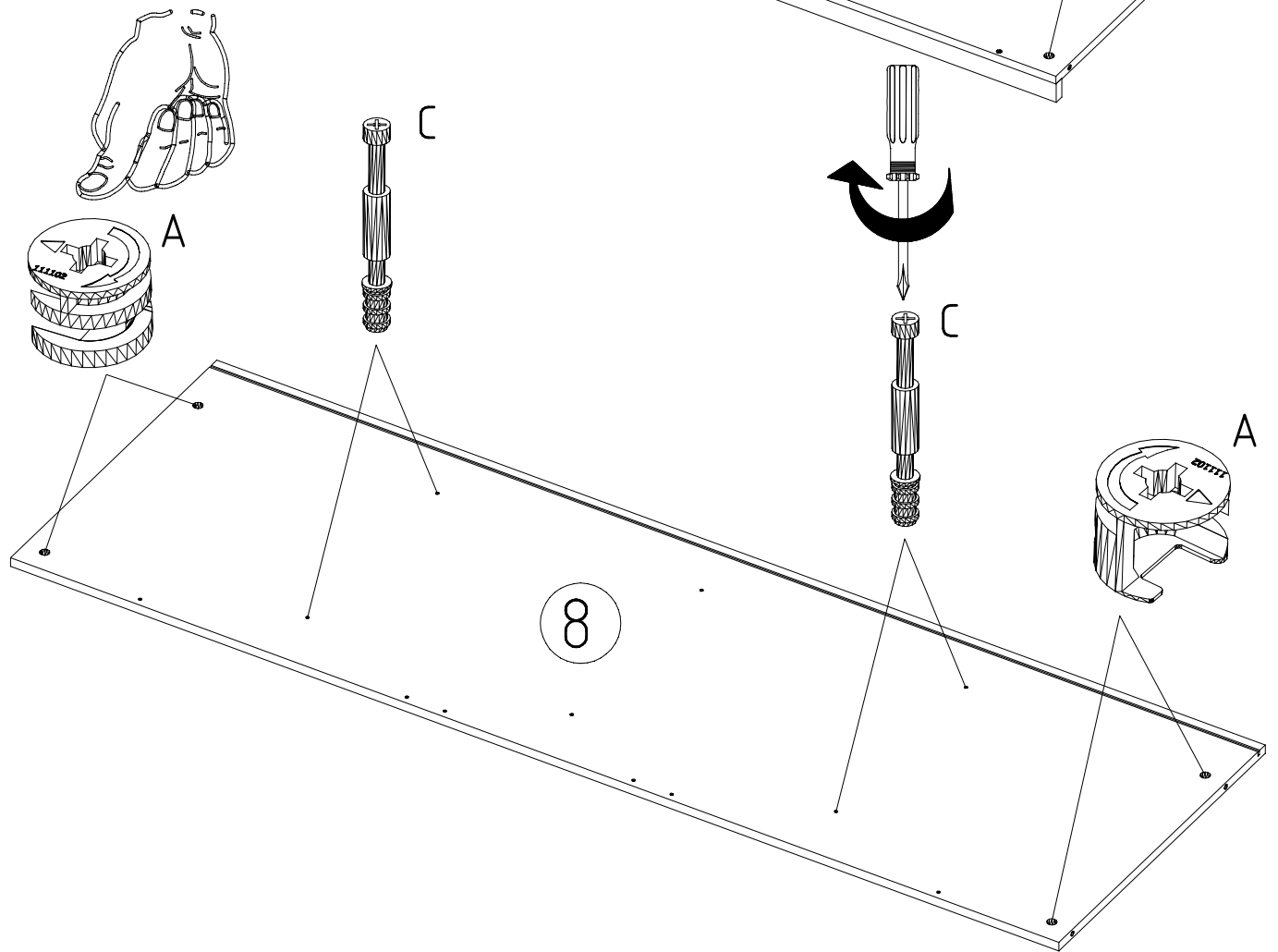
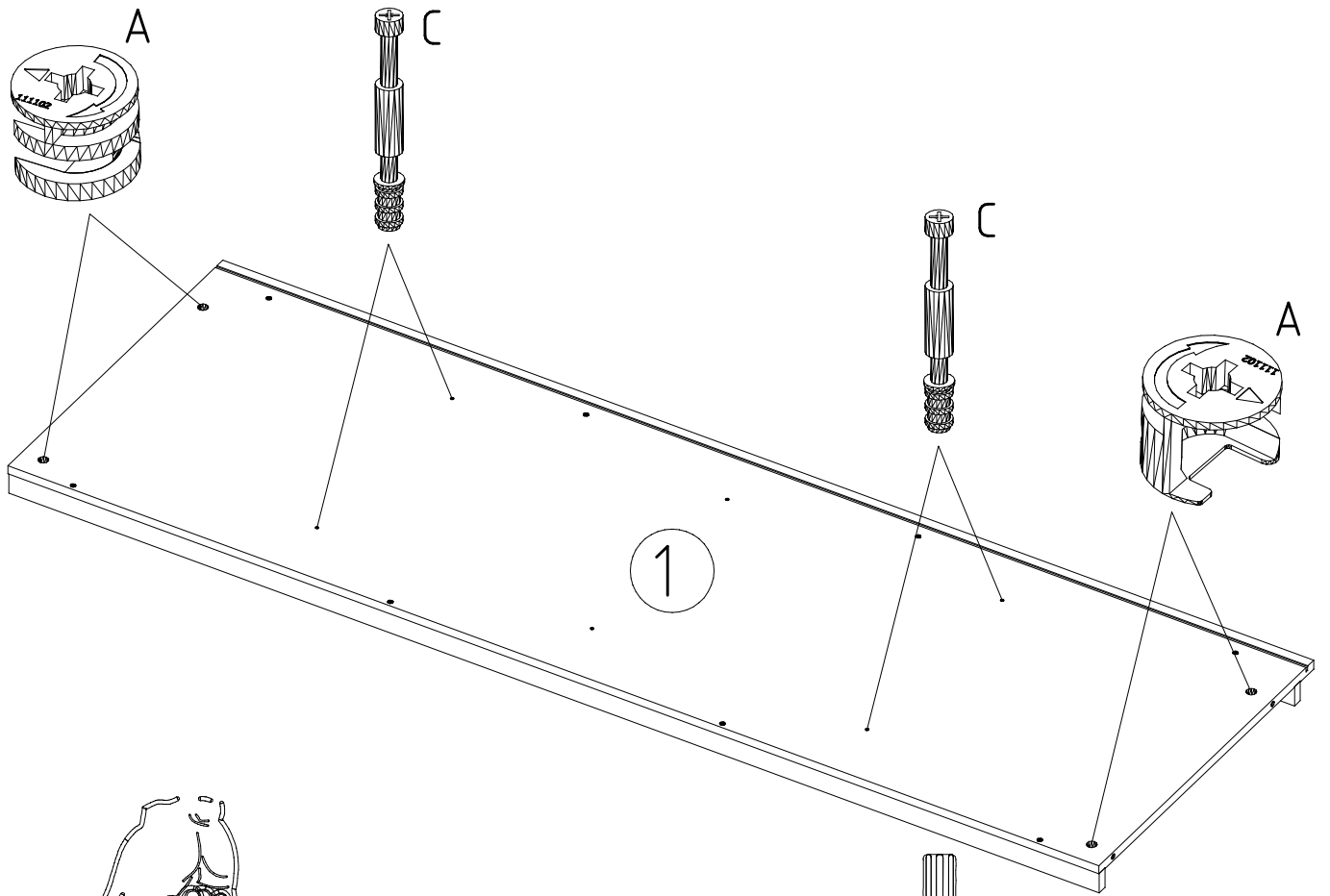
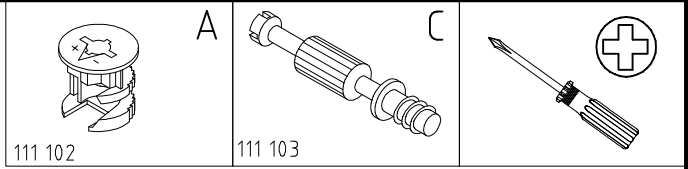

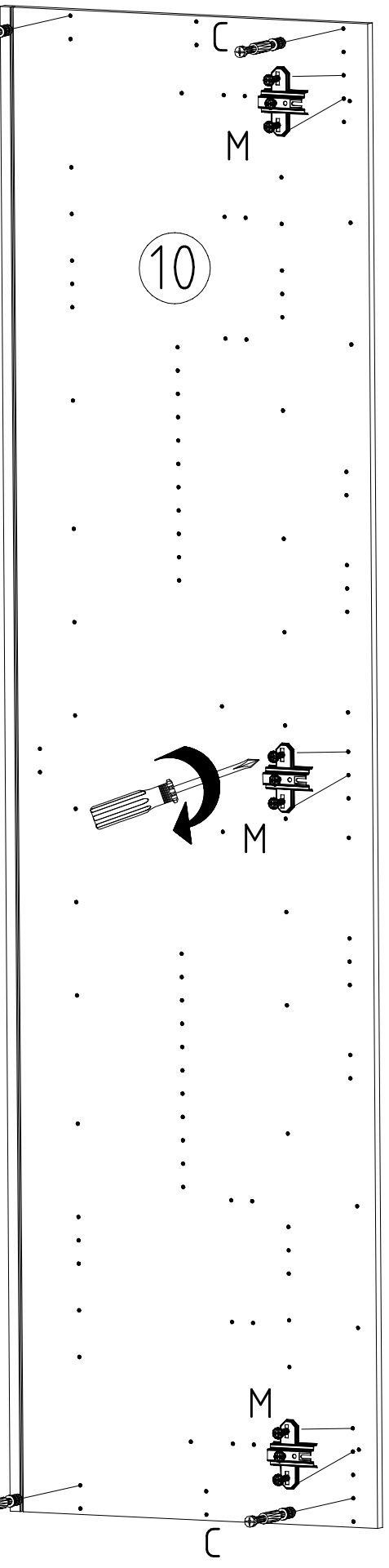
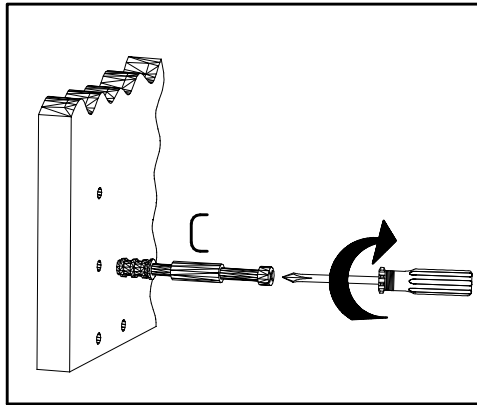
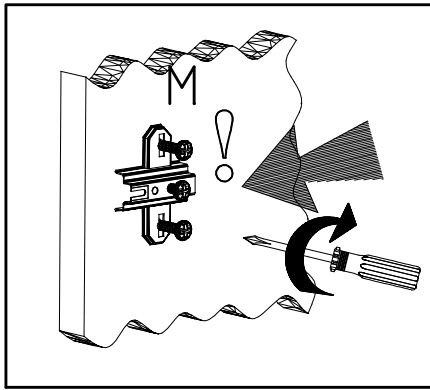
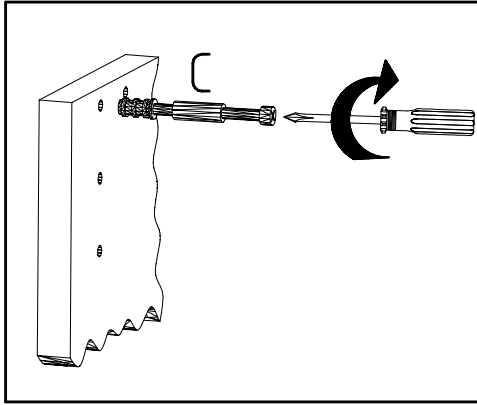
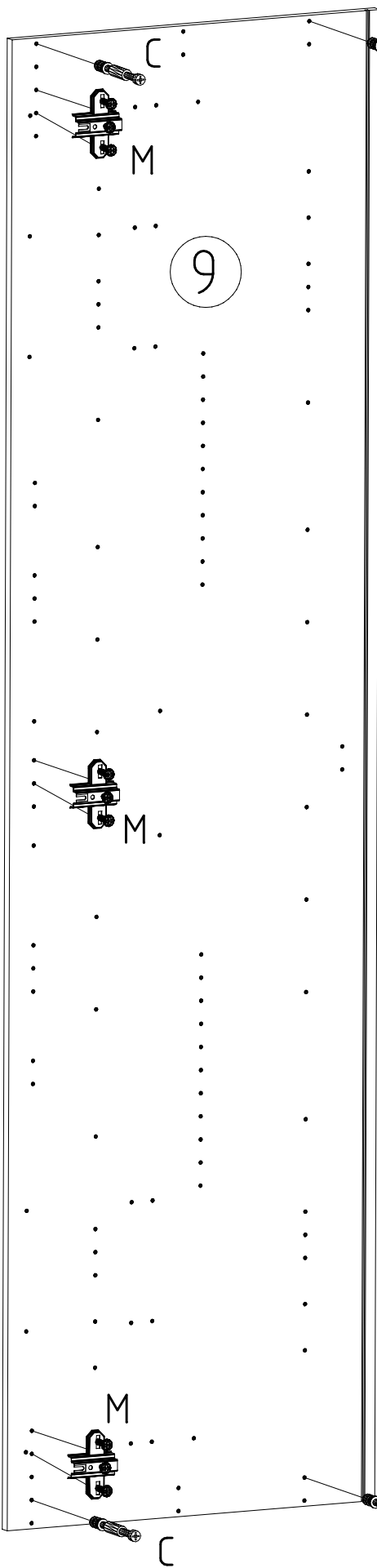
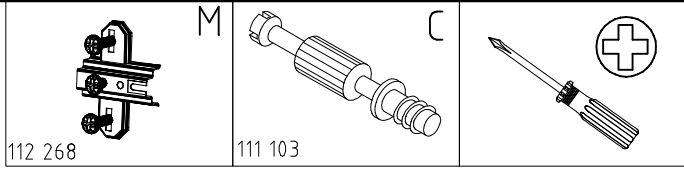

4

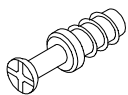

F

111 229

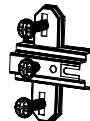

M

112 268



A

111 102

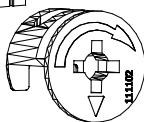
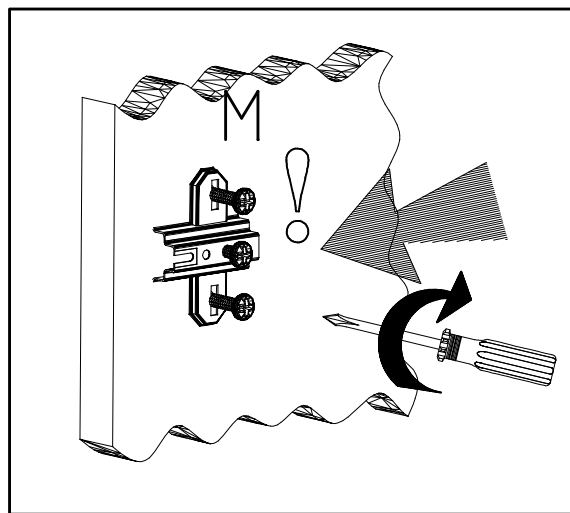
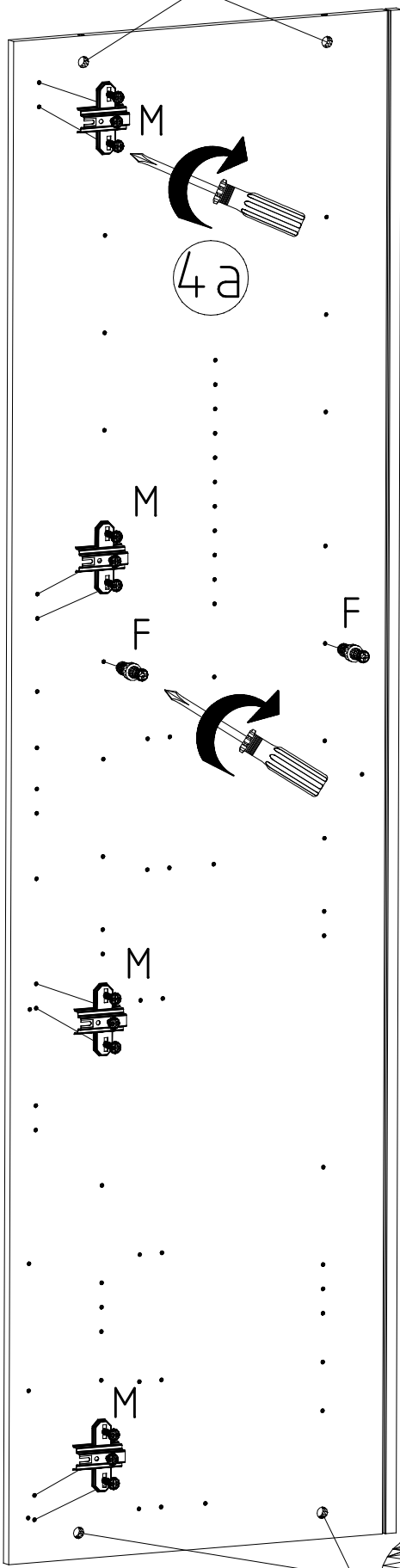
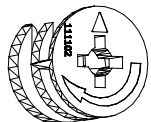
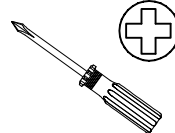

5

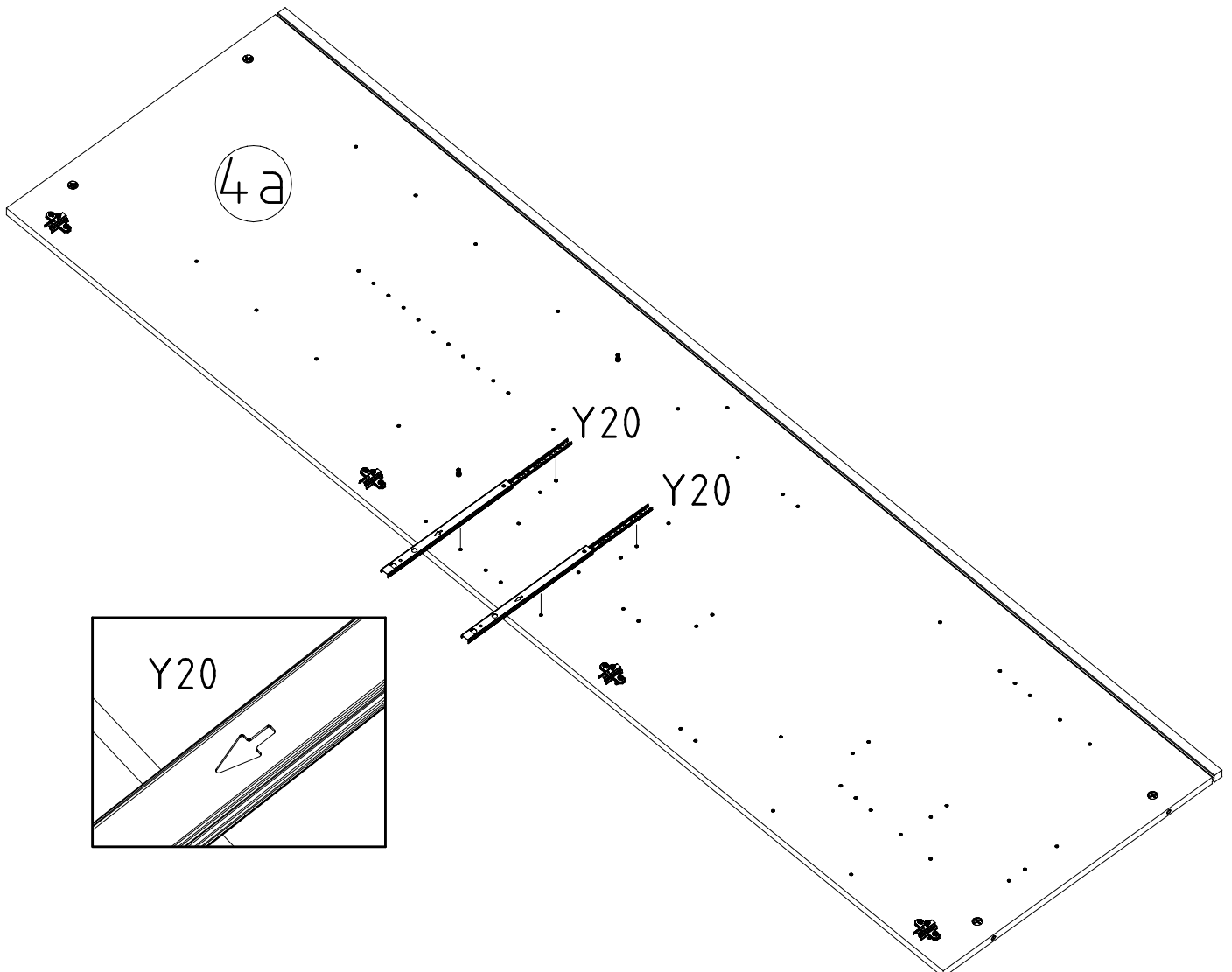
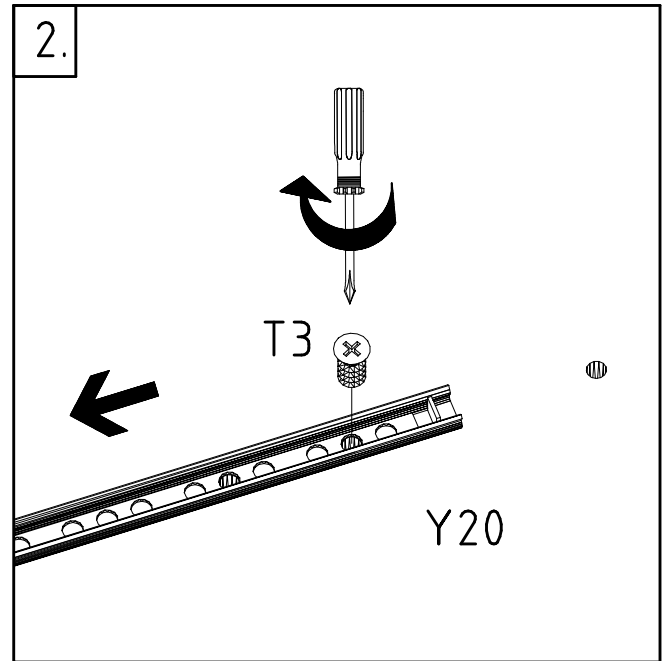
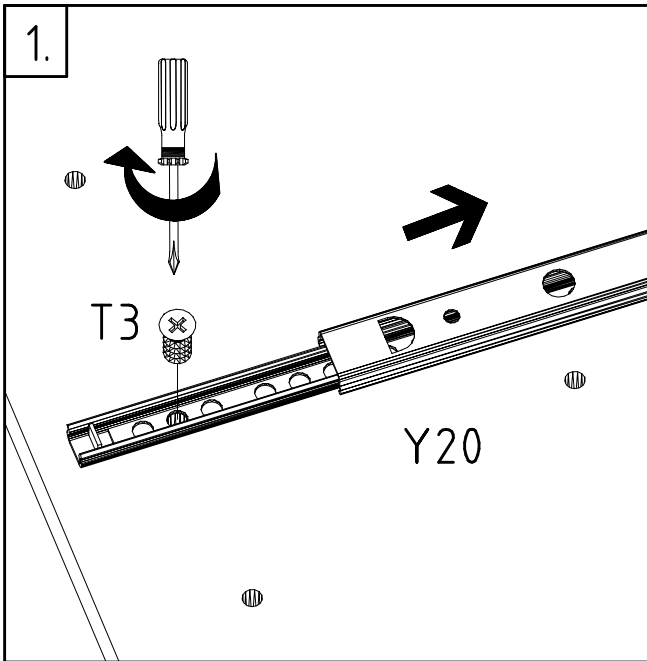
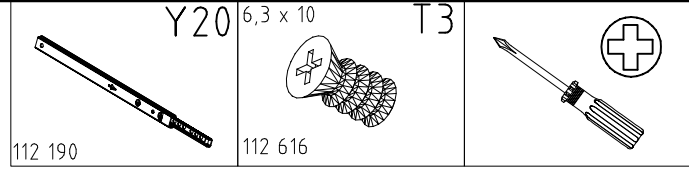

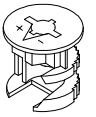

111 102

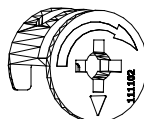
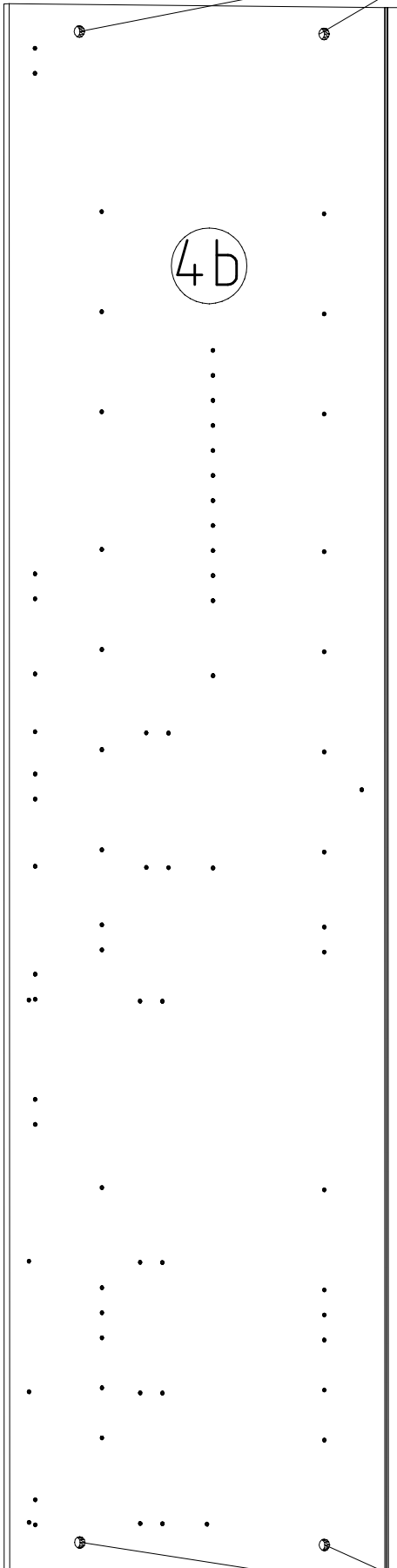
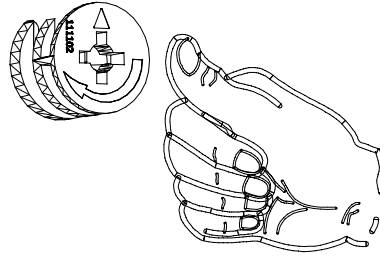

7

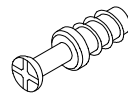

F

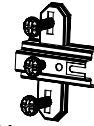

M

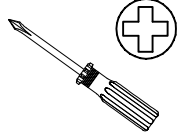

111 229

112 268

4b

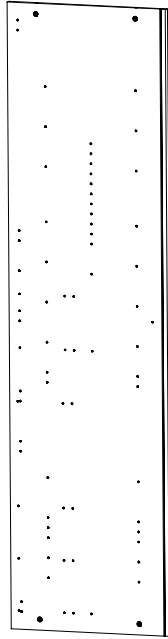

180°

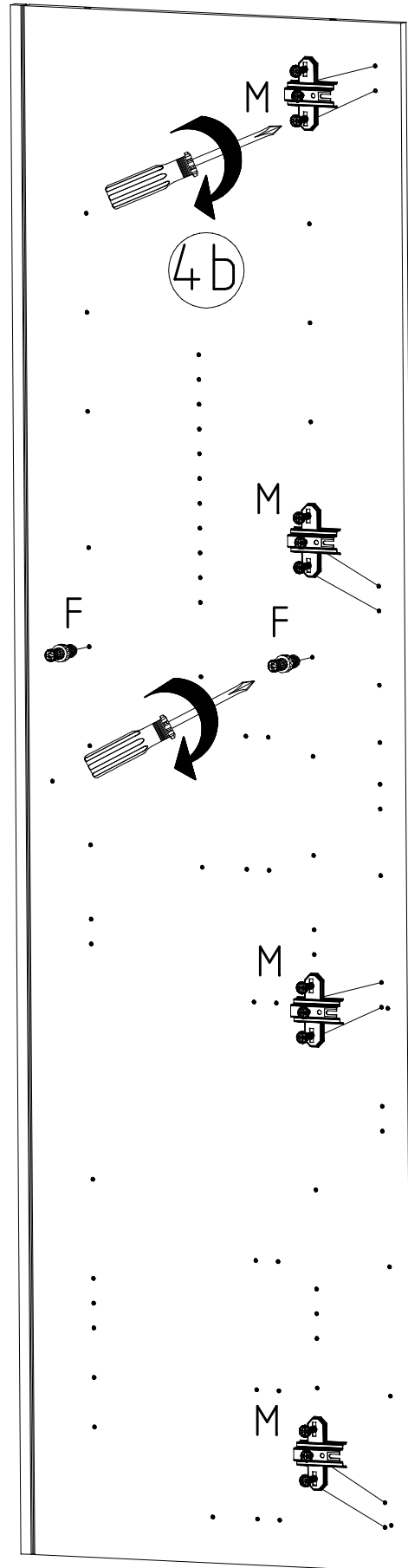
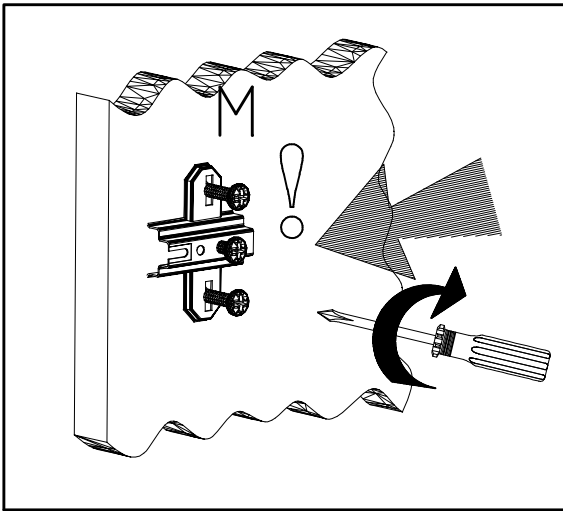

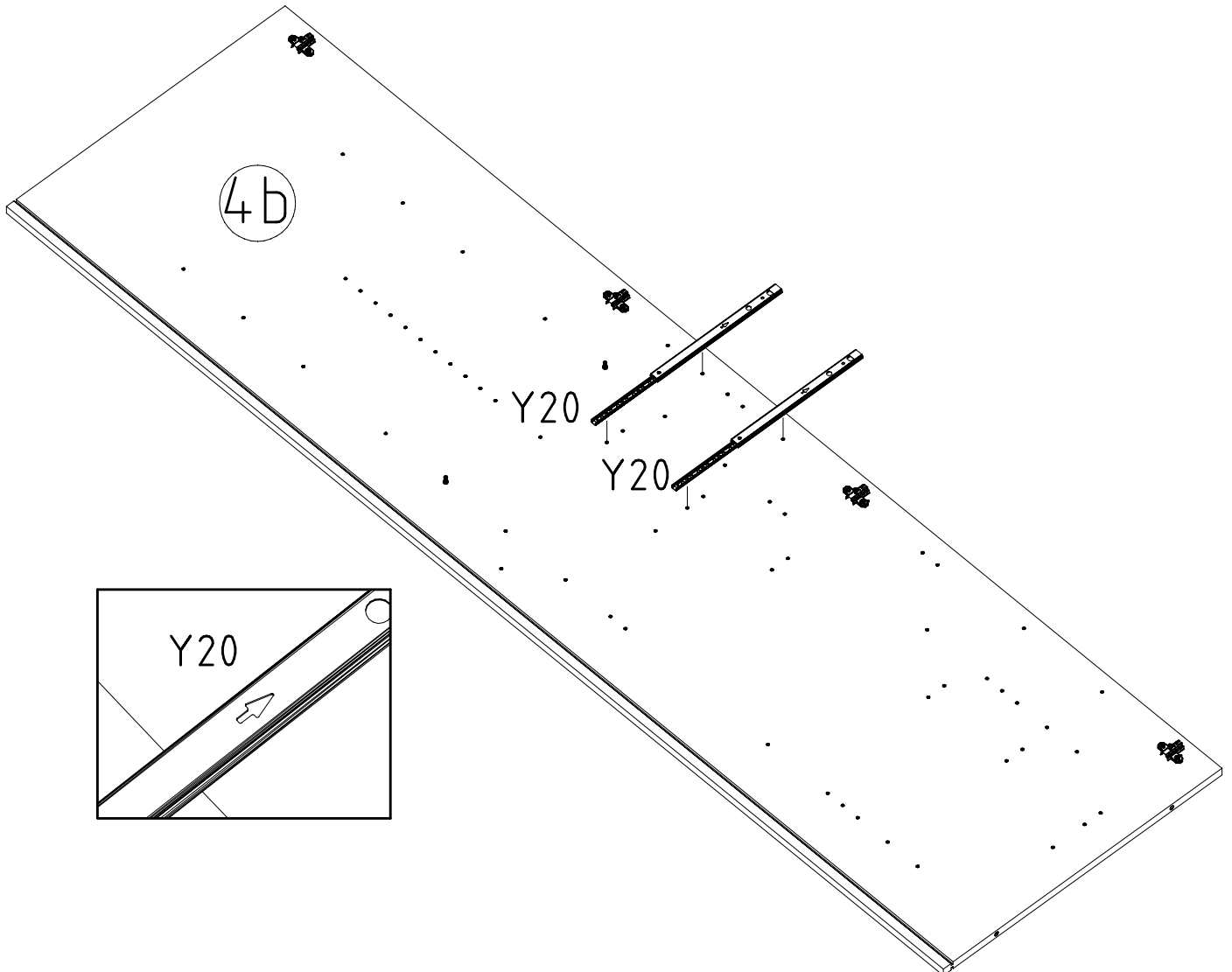
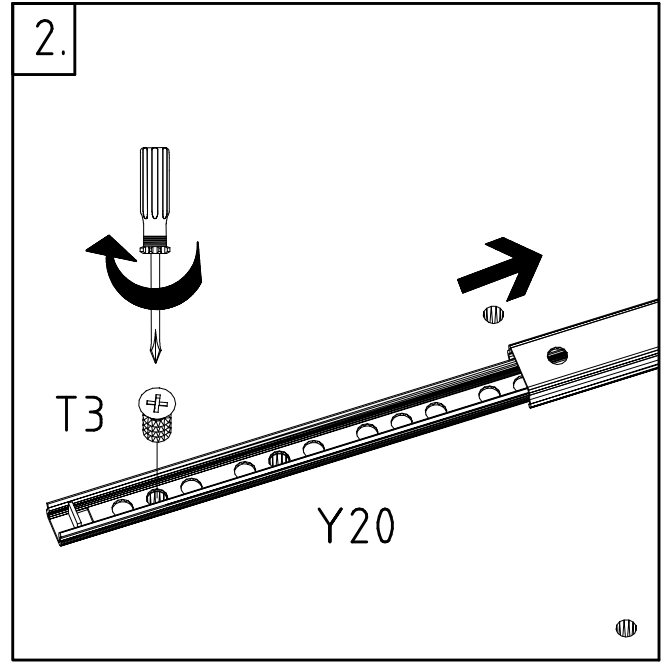
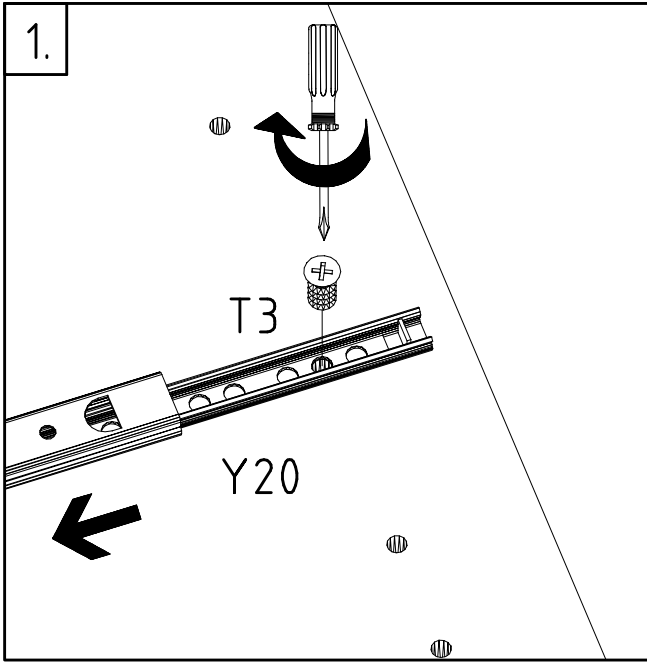
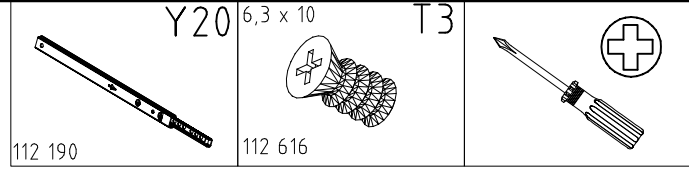



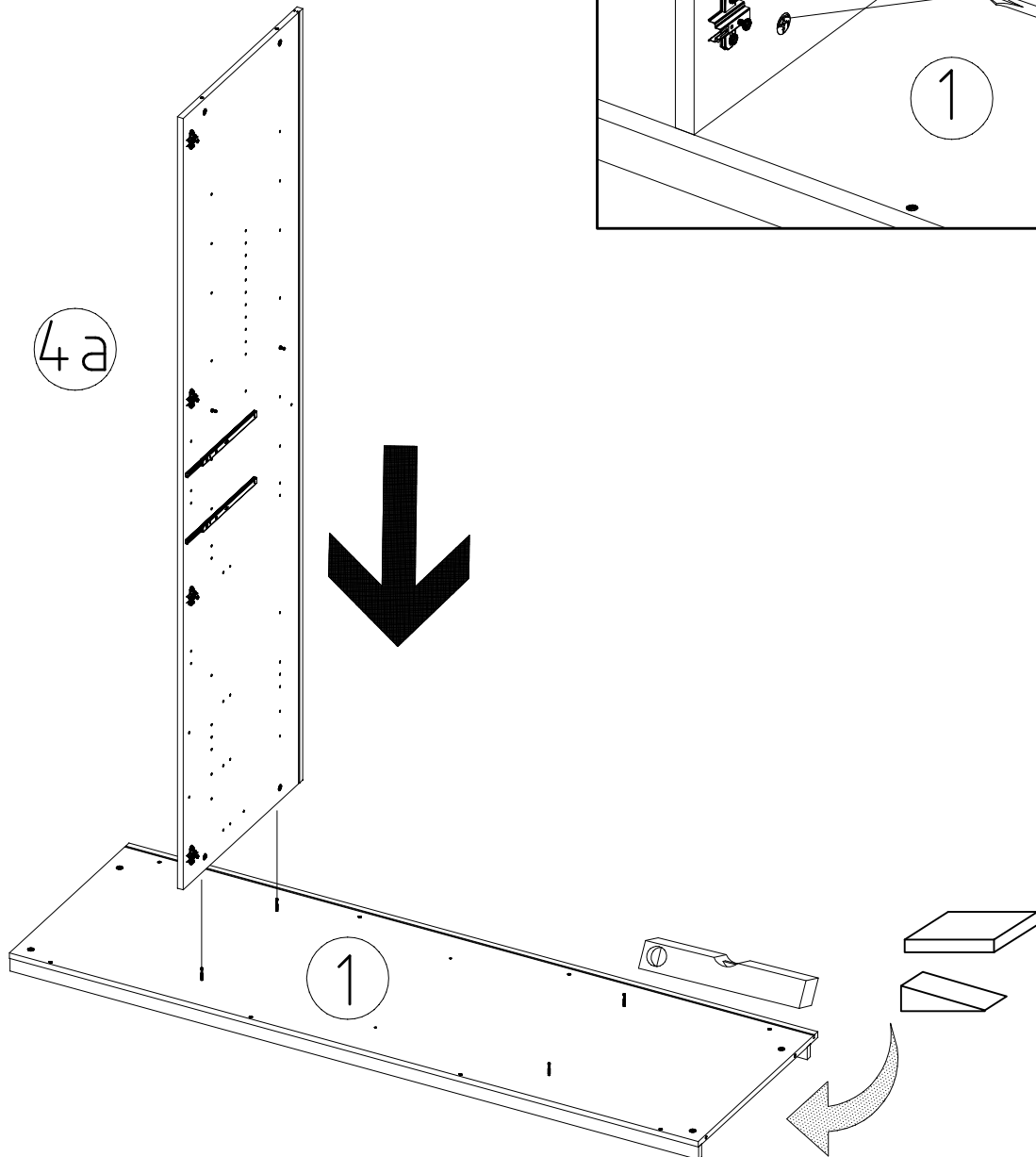
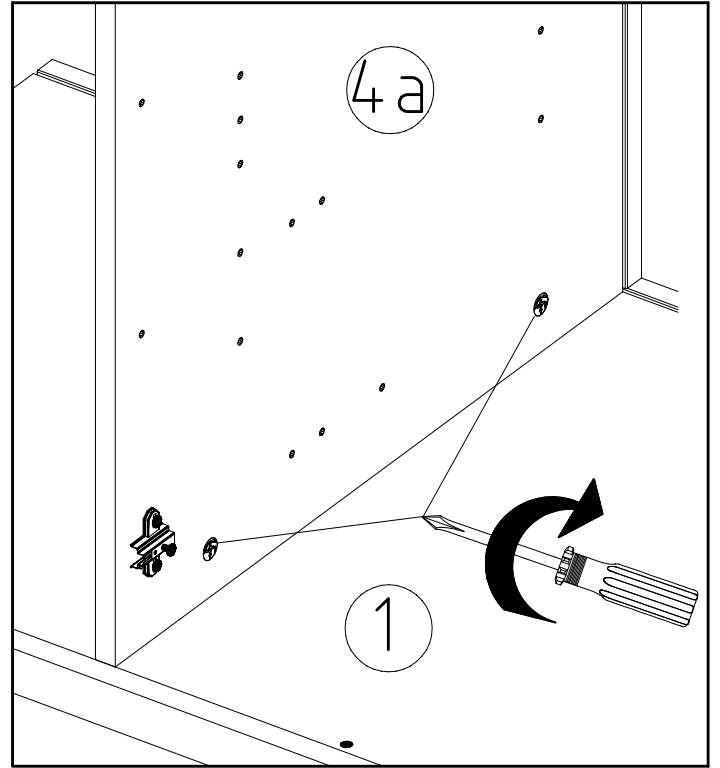
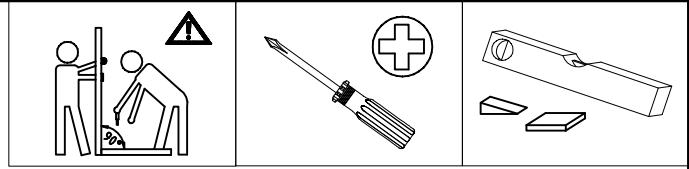

9

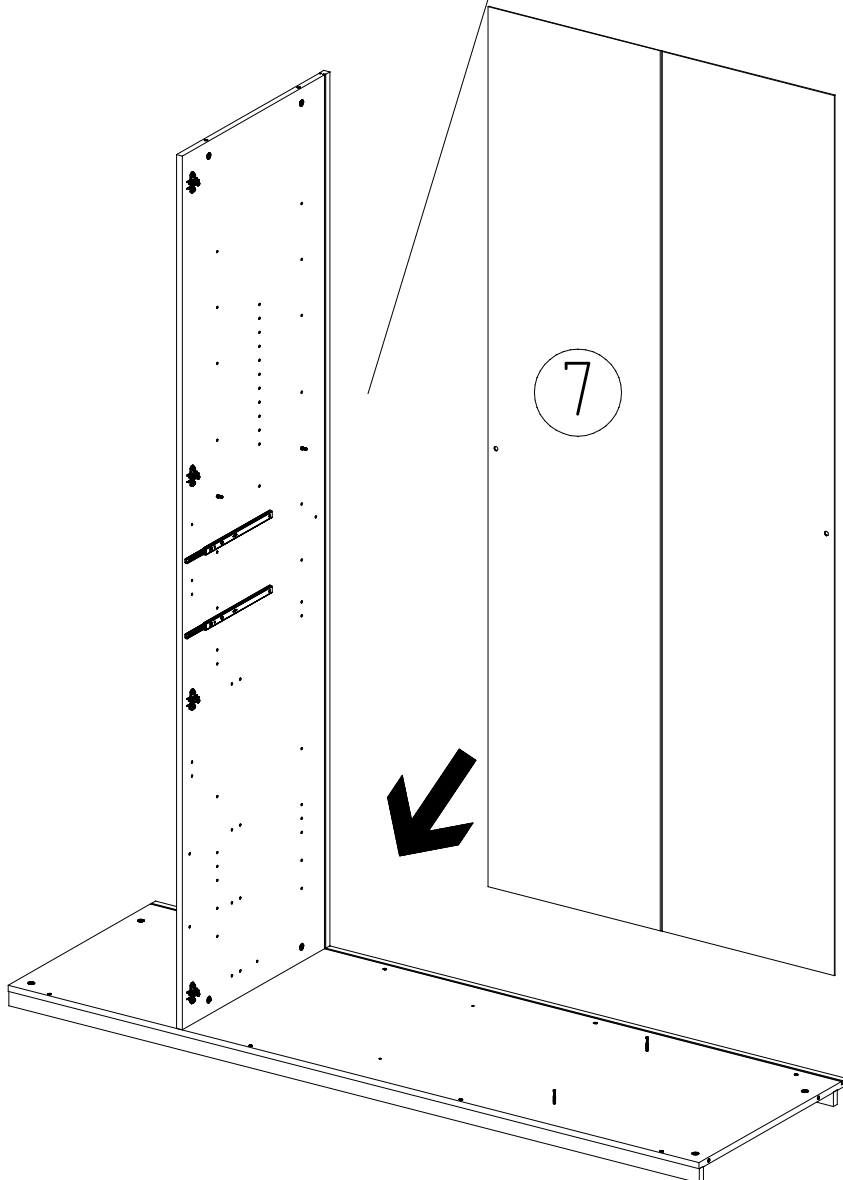
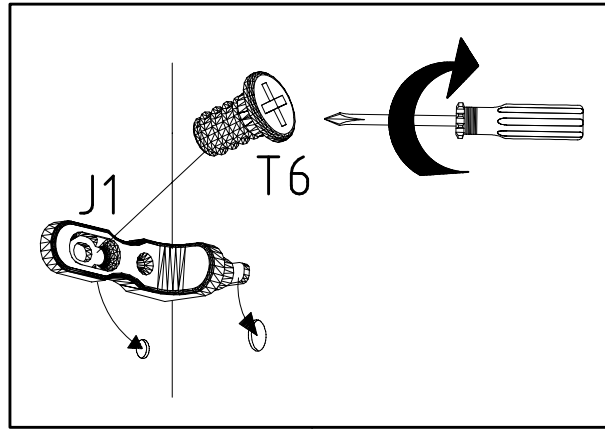
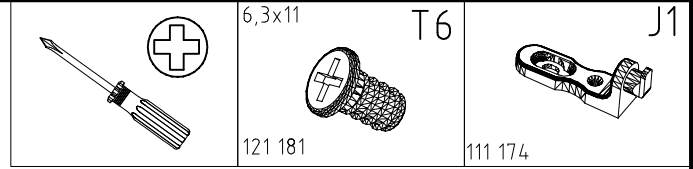

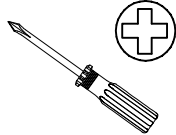

10

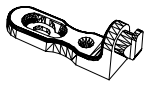

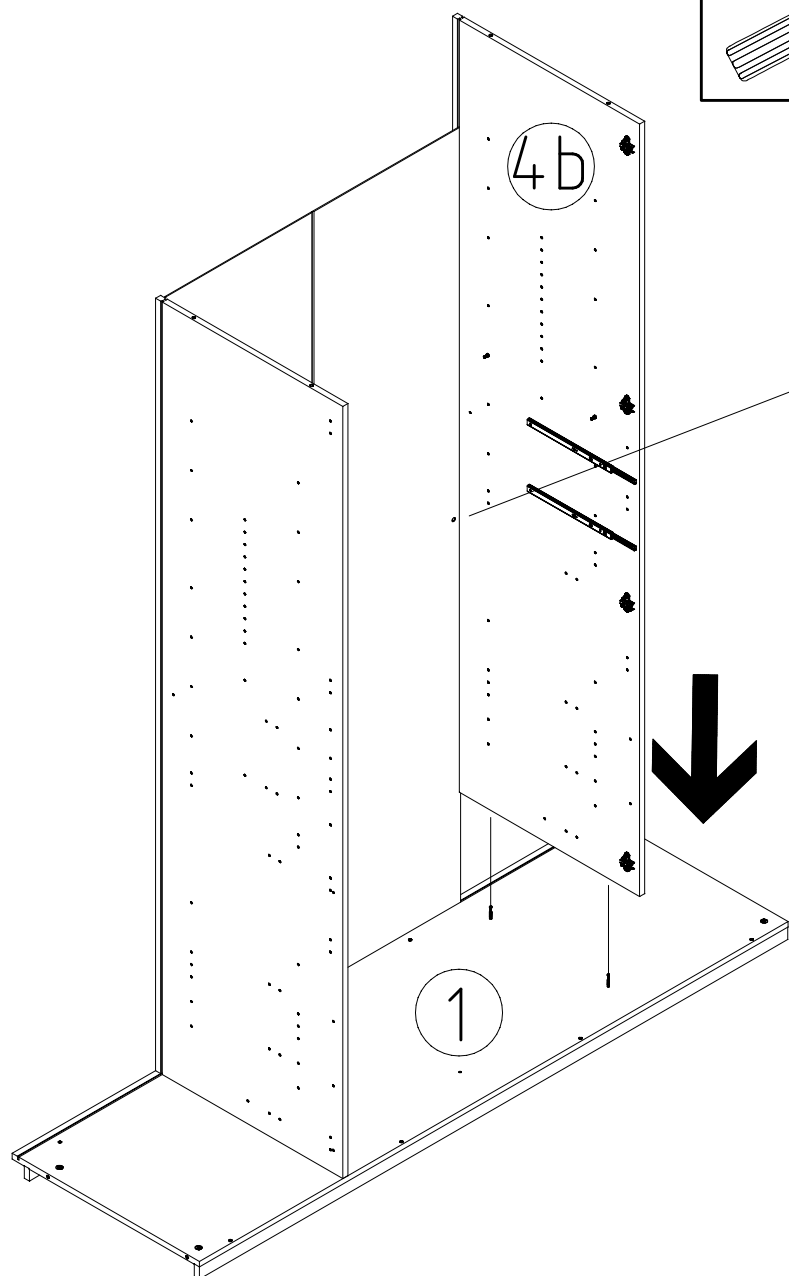
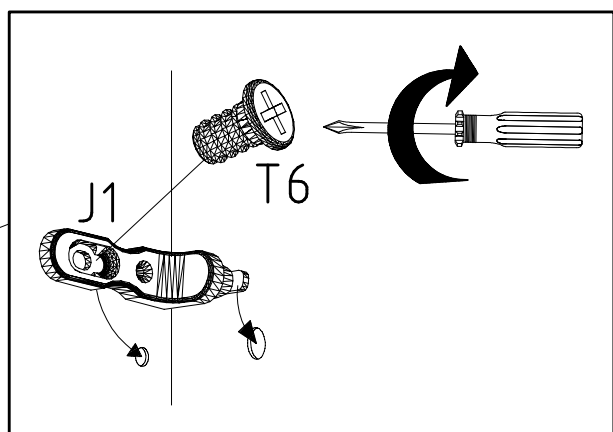
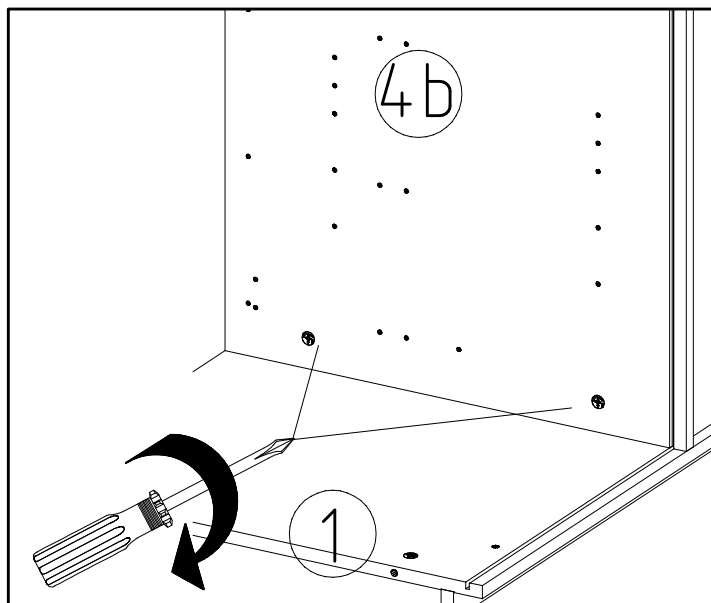
		6,3x11 121 181	T6 	J1 	111 174
--	---	-------------------	--	--	---------

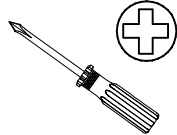

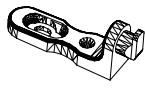
		6,3x11 121 181	T6  111 174	 J1
--	---	-------------------	---	--

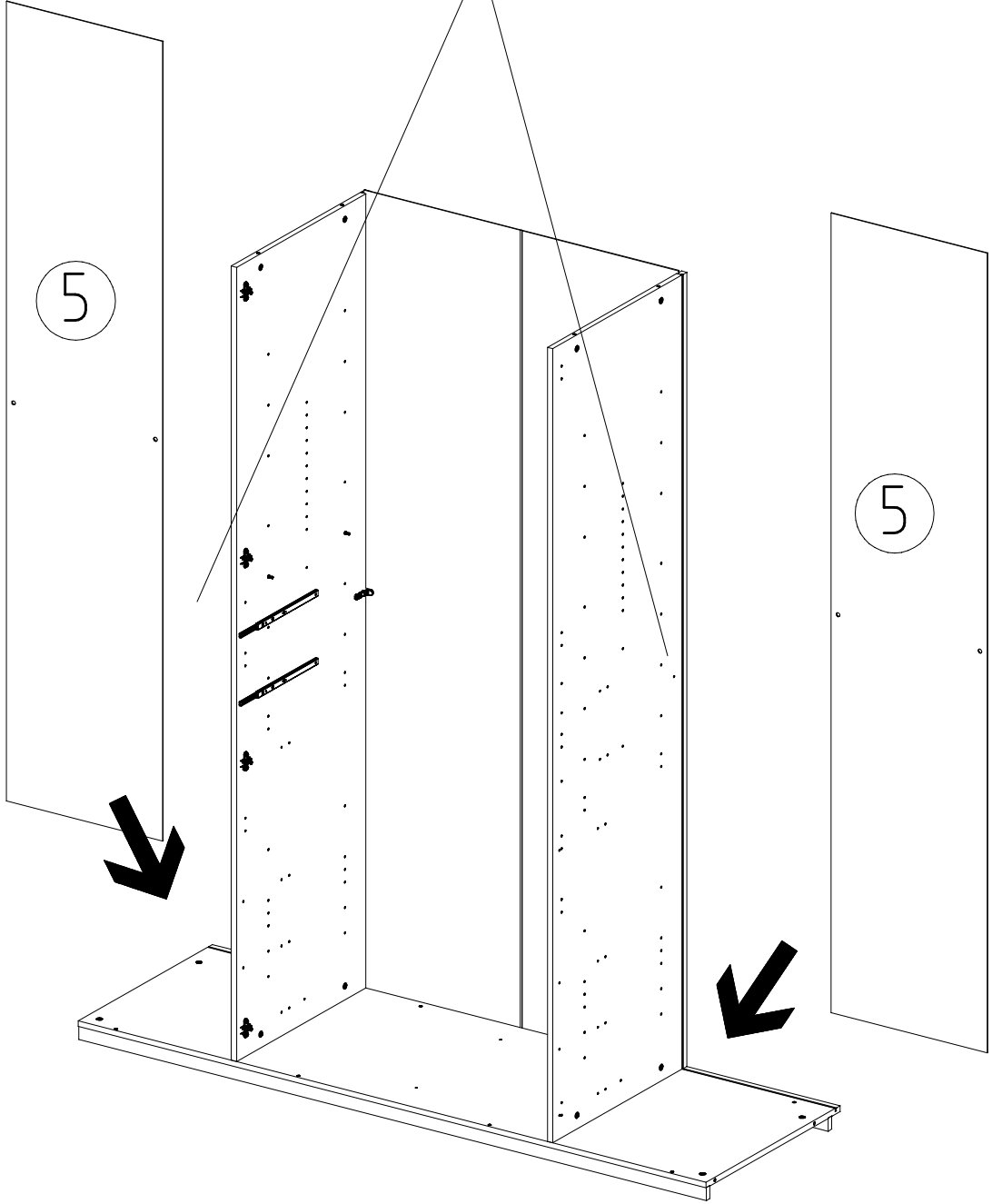
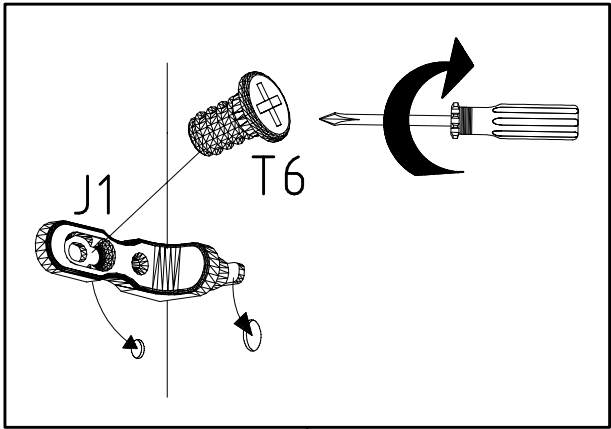

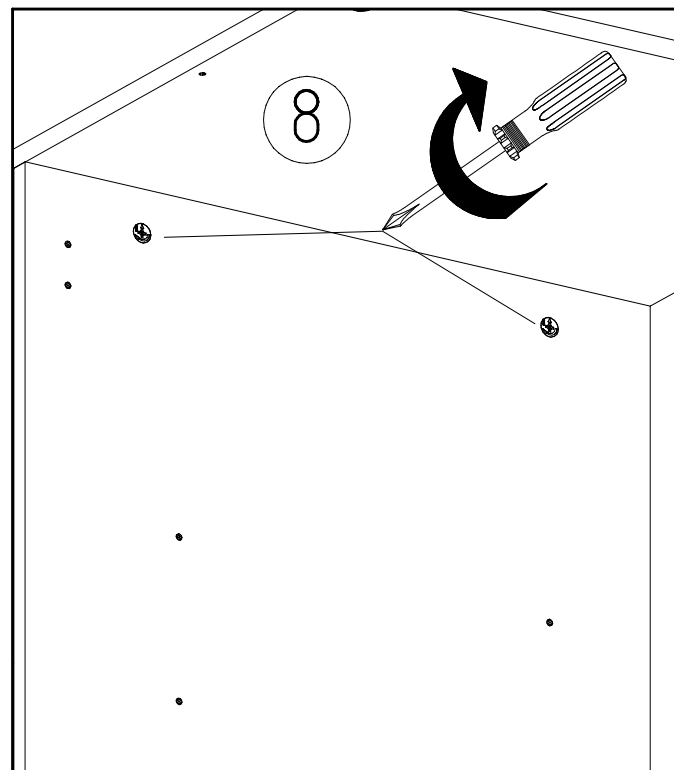
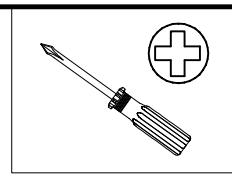
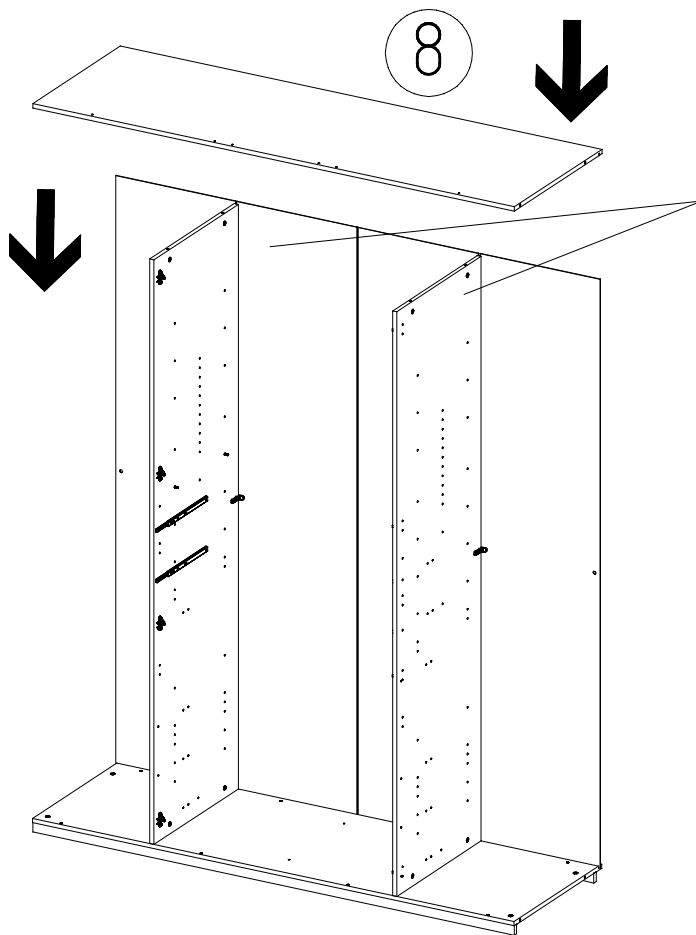

13

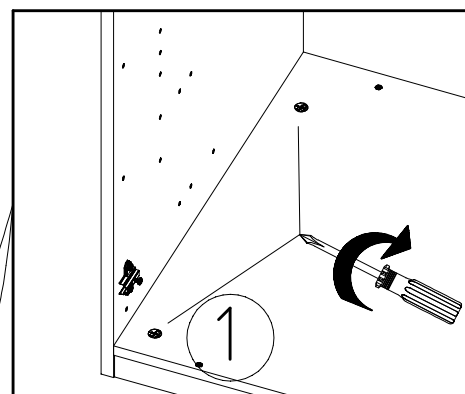
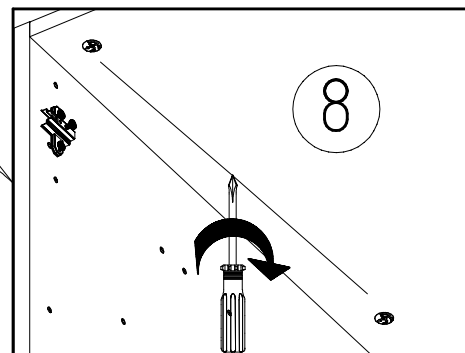
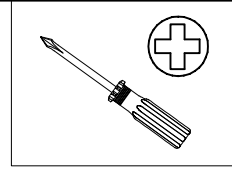
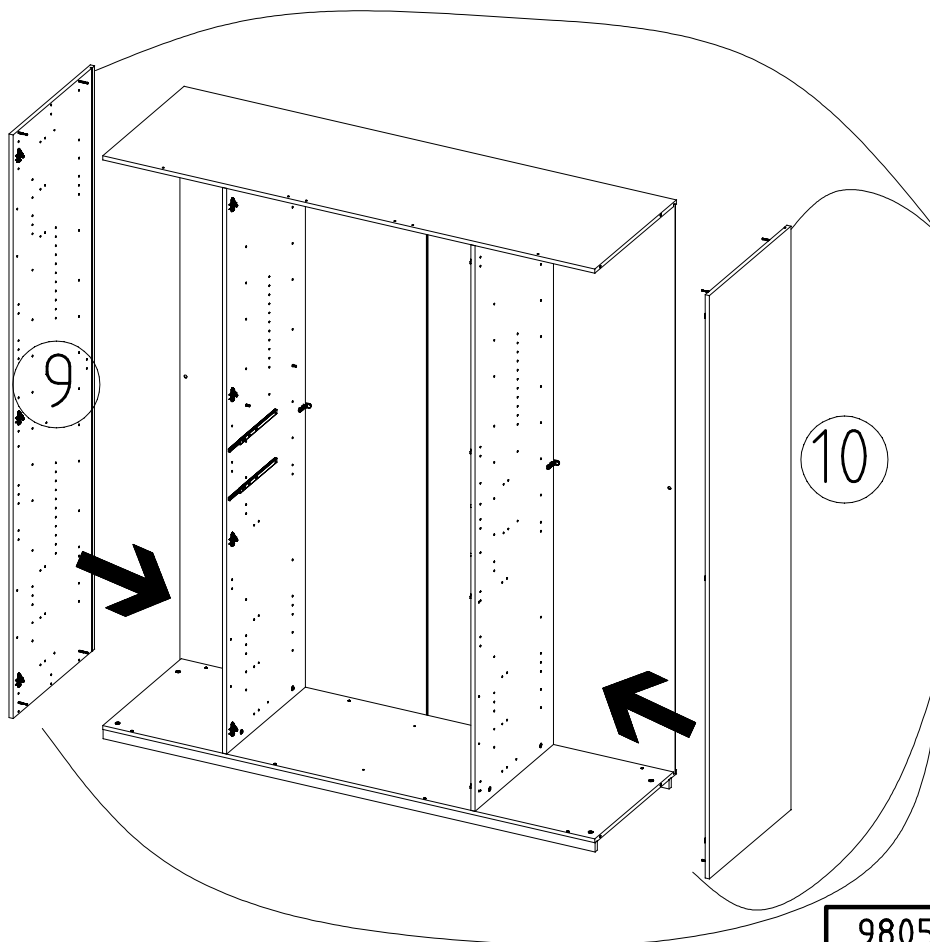

14

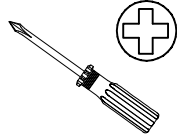

15

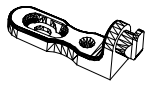
	<p>6,3x11</p>  <p>T6</p> <p>121 181</p>	 <p>J1</p> <p>111 174</p>
---	---	---

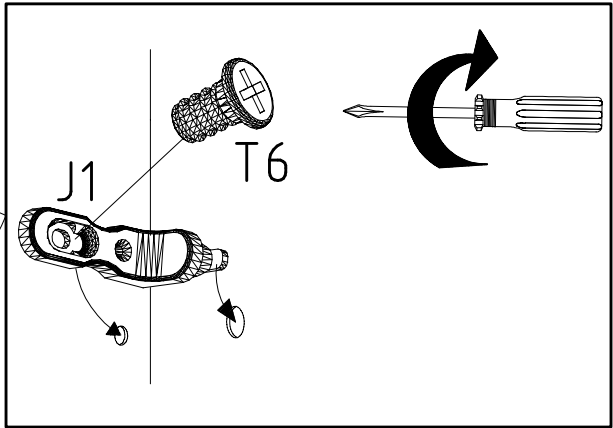
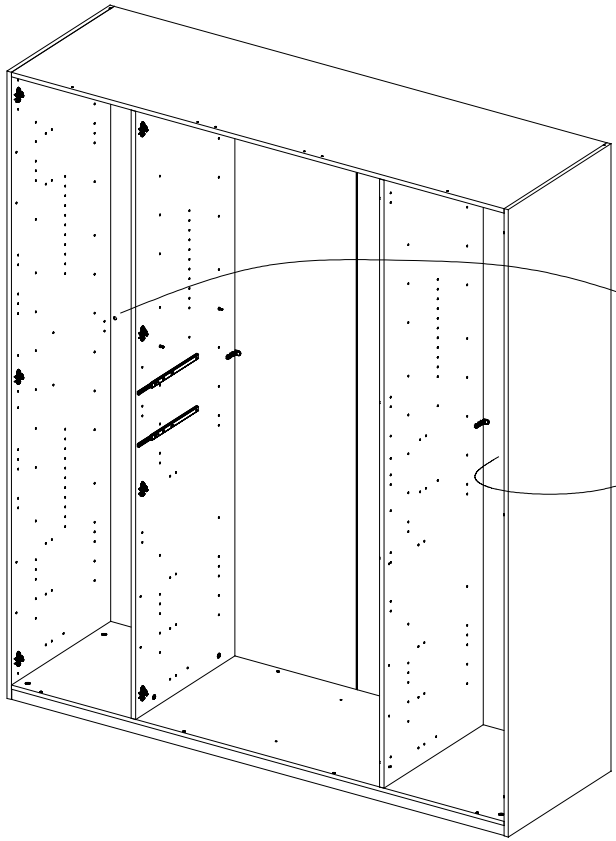

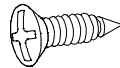
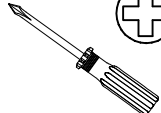

16

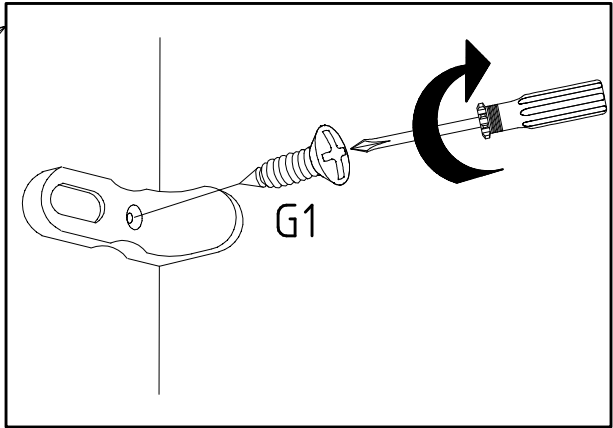
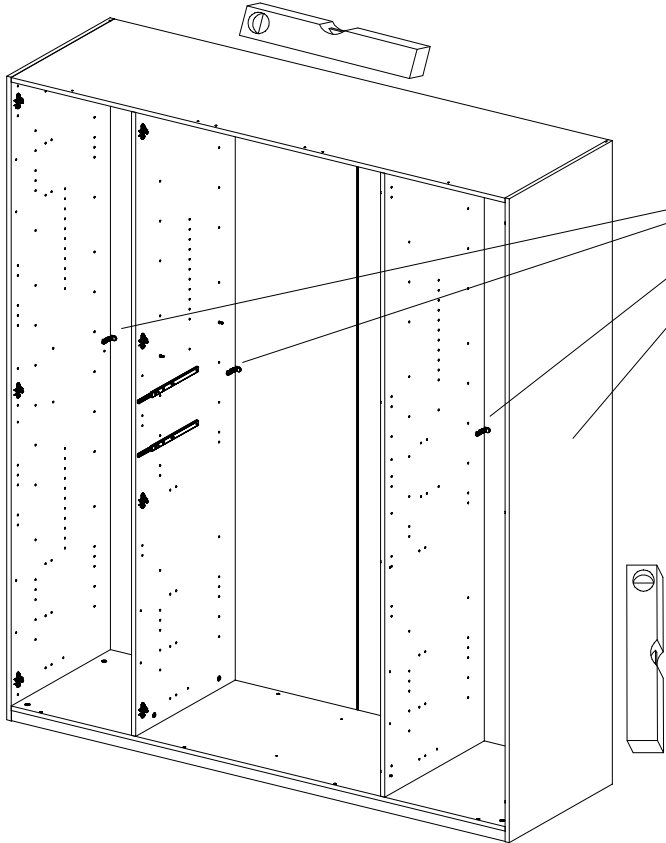
<p>3,5 x 15 mm</p>  <p>G1</p> <p>121 370</p>	
---	---

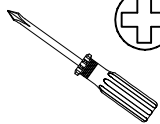
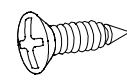
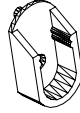
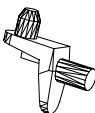

17

 121 370	 3,5 x 15 mm G1 117 001	 K1 111 610	 L7 112 403	 422mm K44
---	--	--	---	--

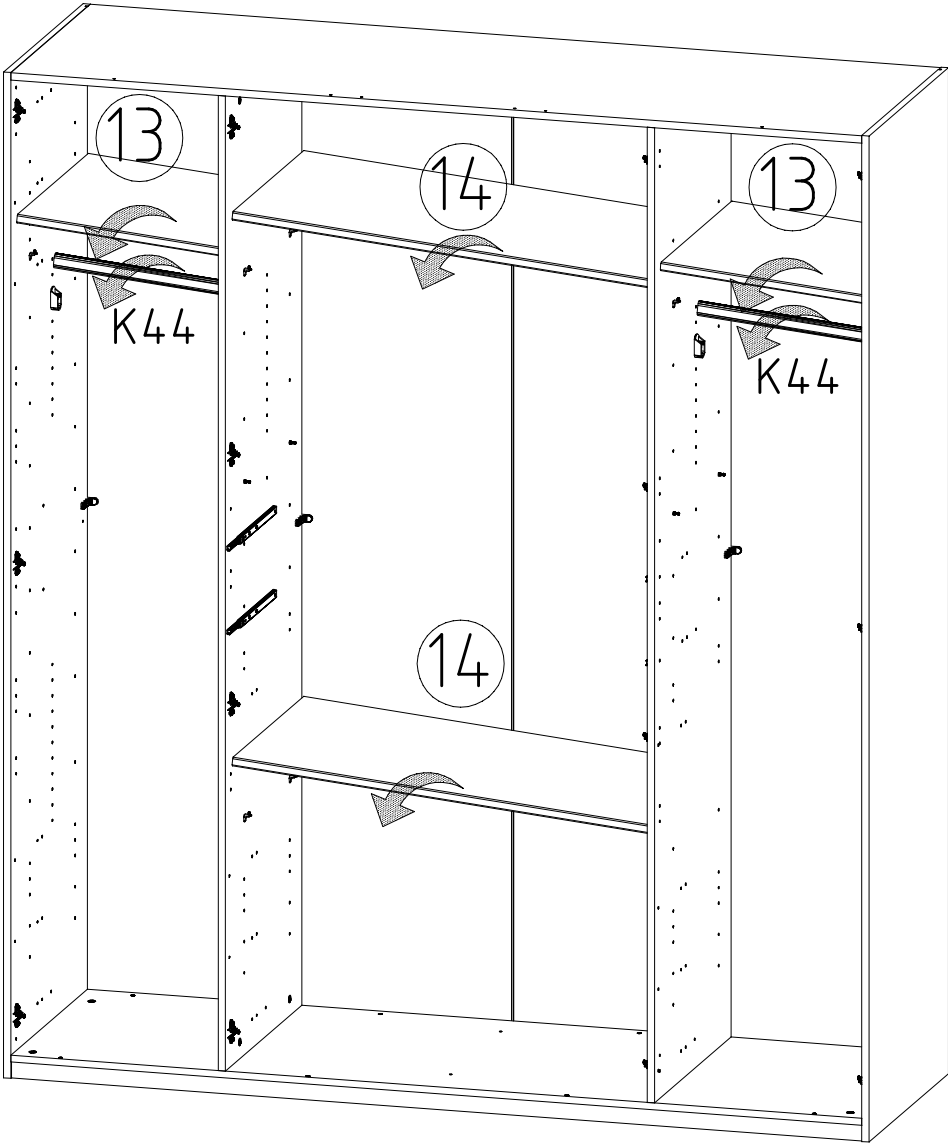
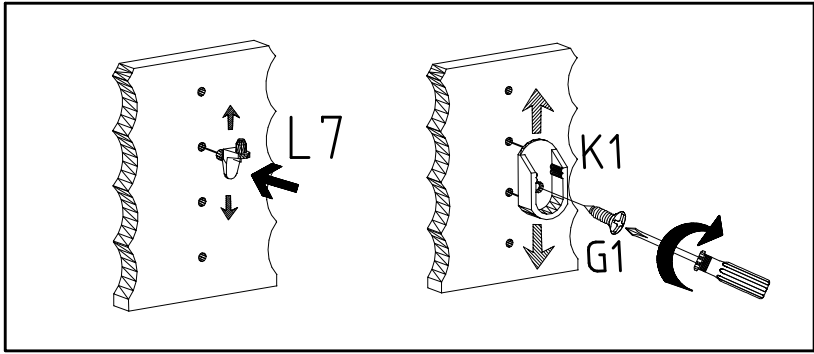

18

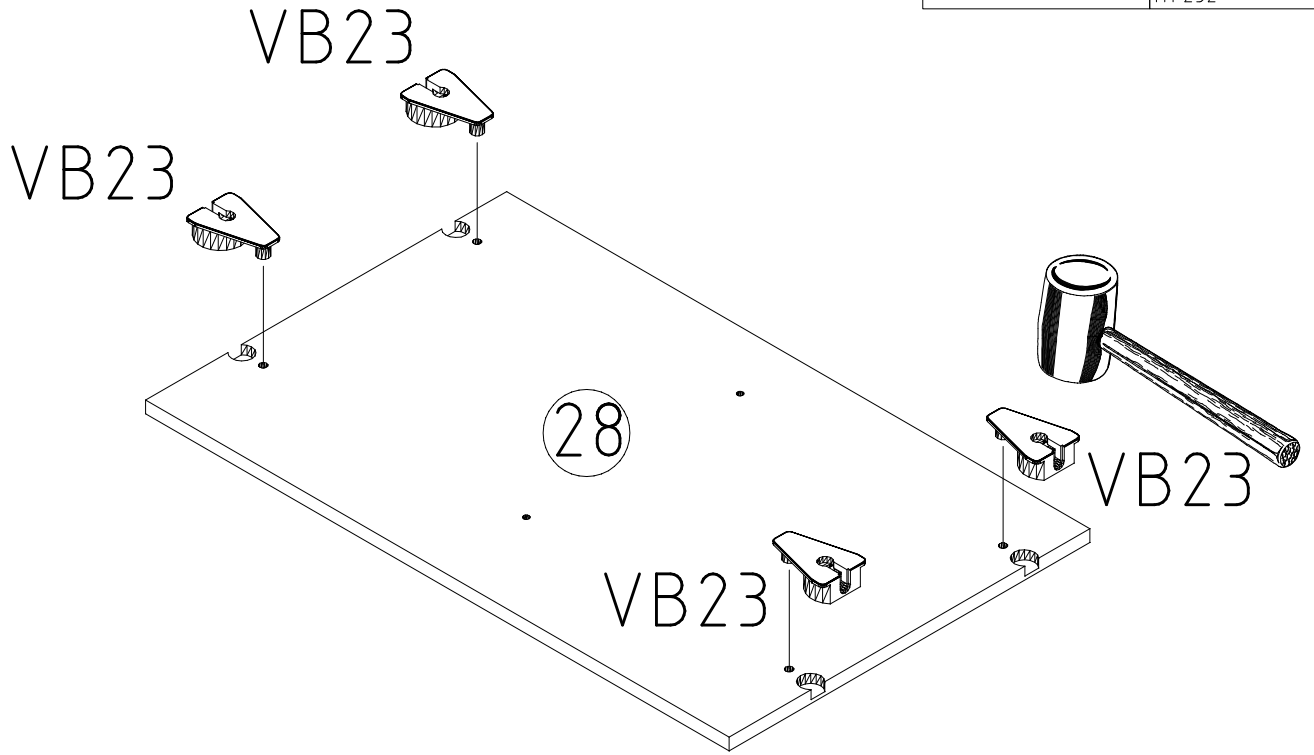
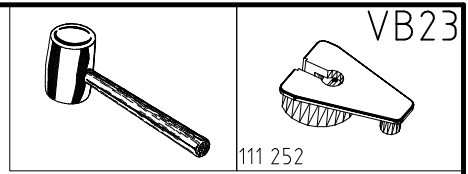

19

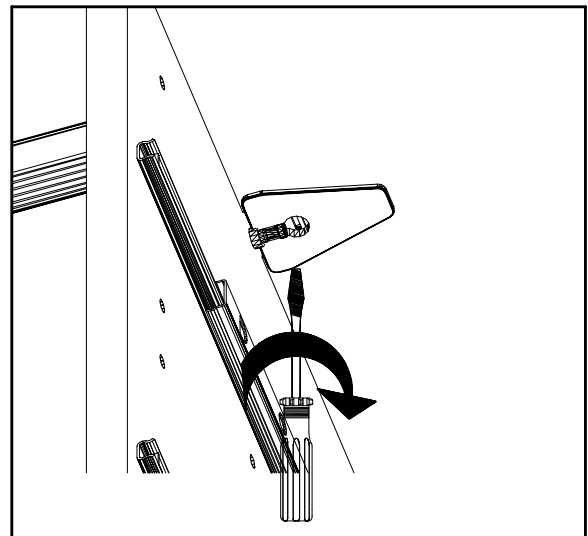
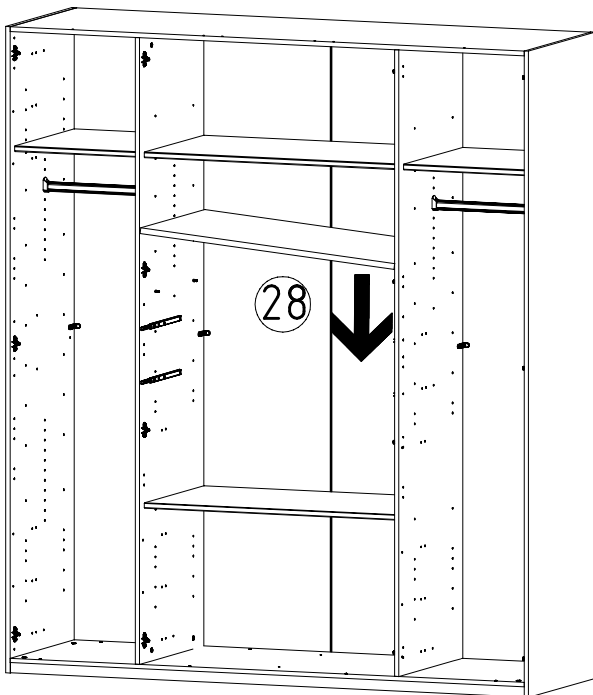
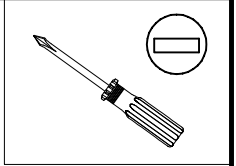

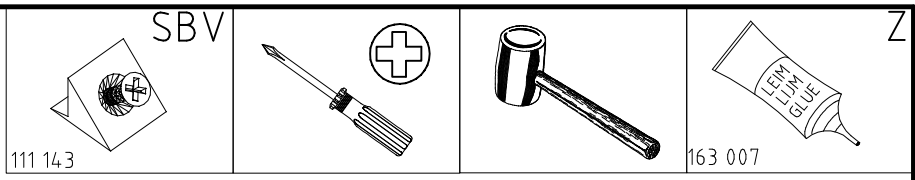

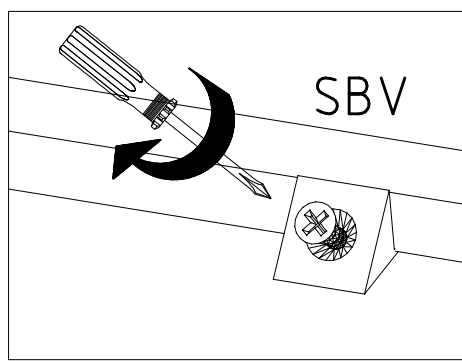
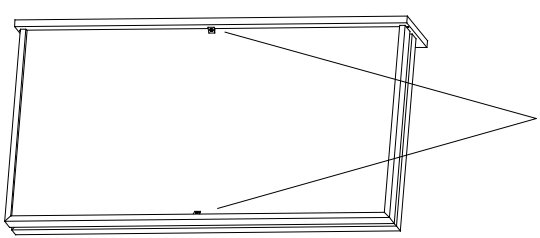
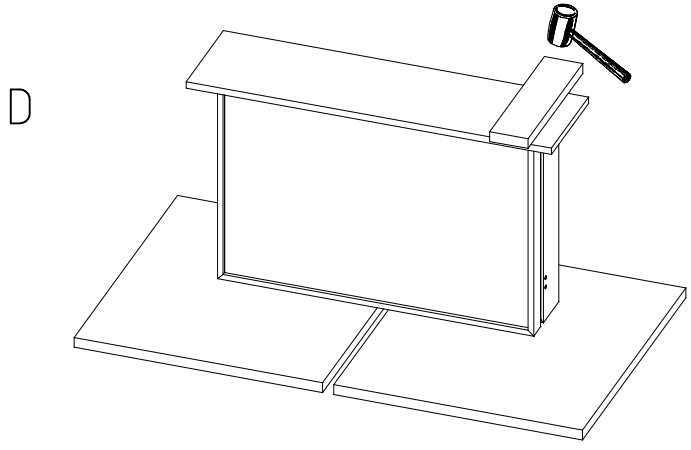
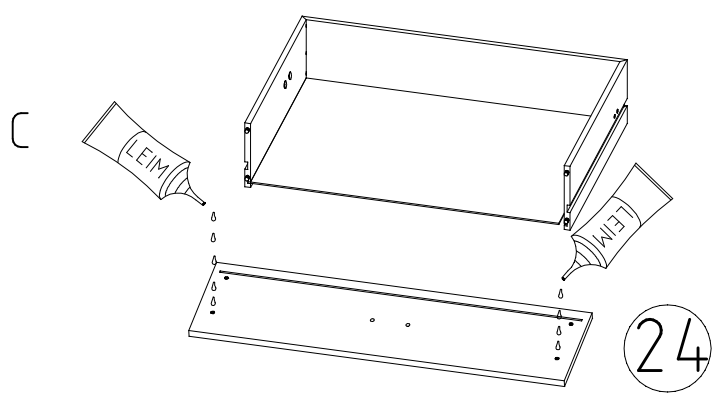
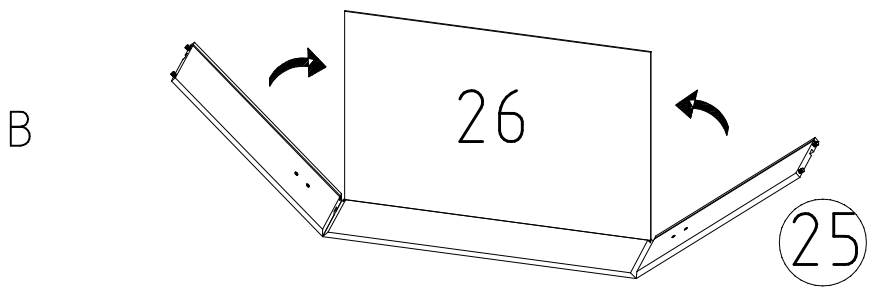
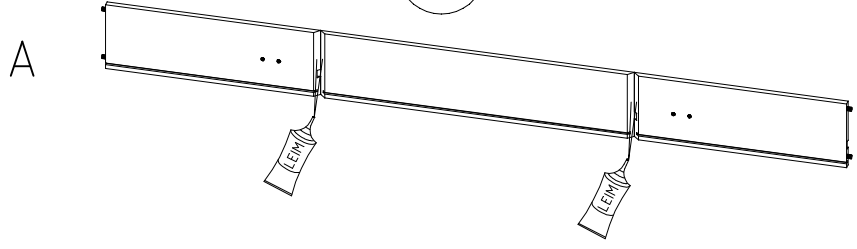

2x

25

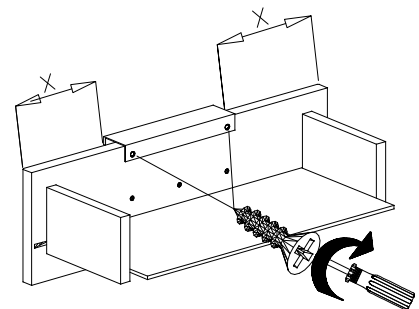
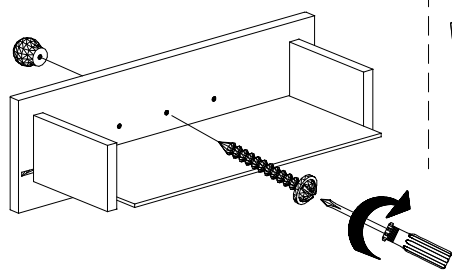
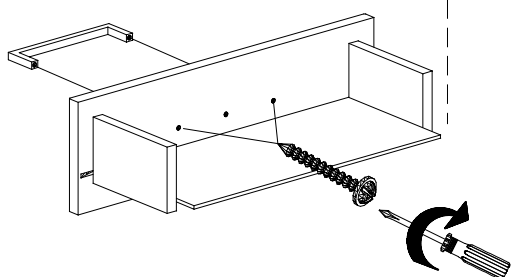
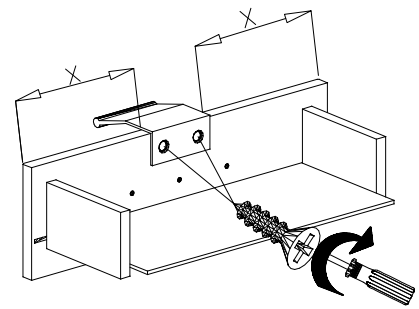
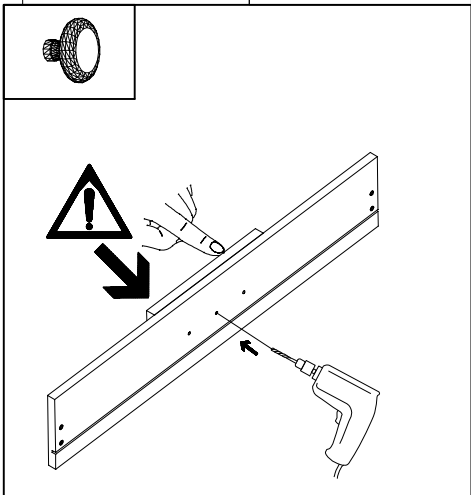
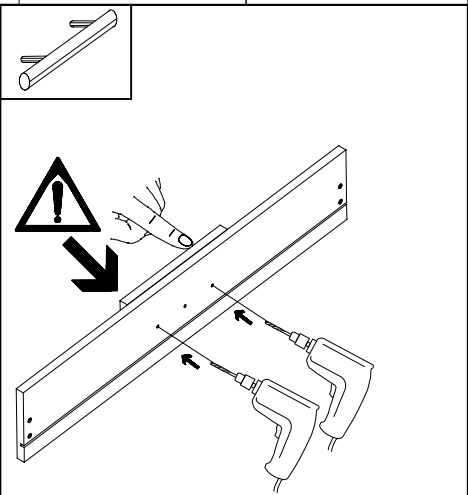
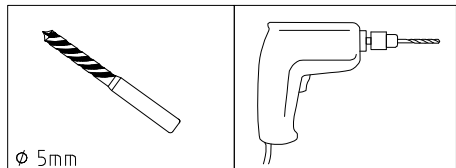
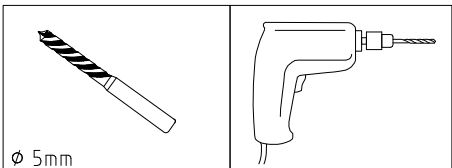
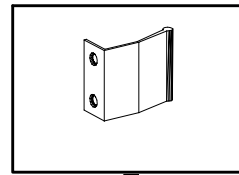
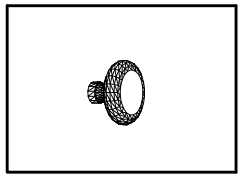
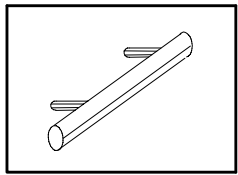
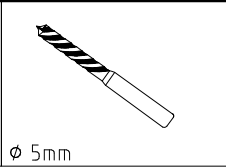
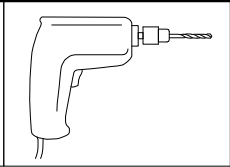
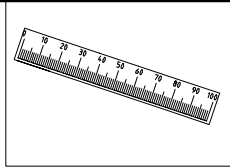



M4 x 9 mm G8

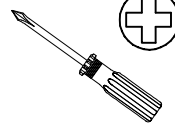

111 015

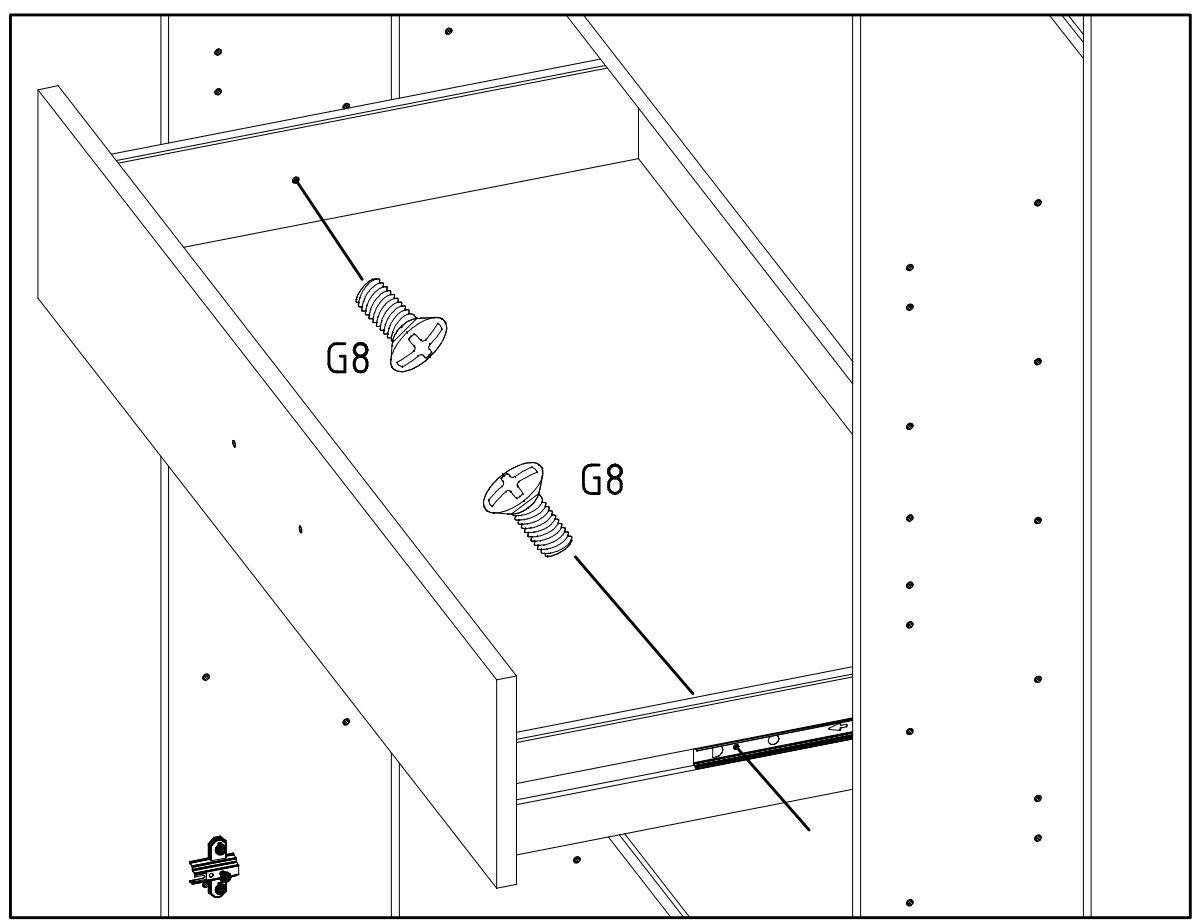
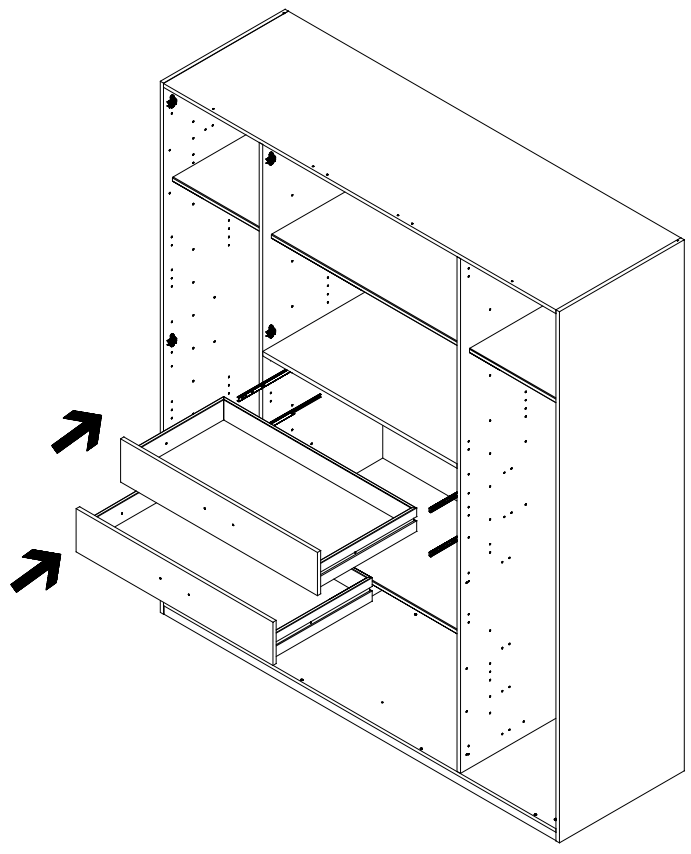

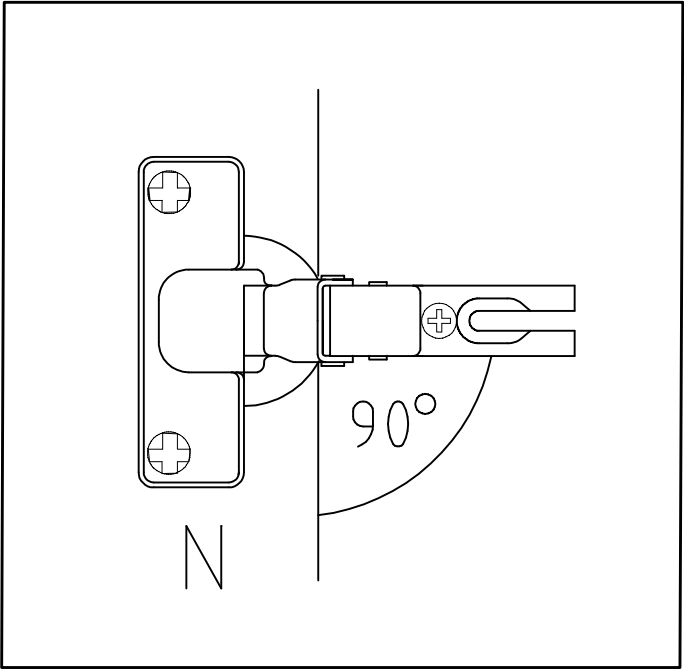
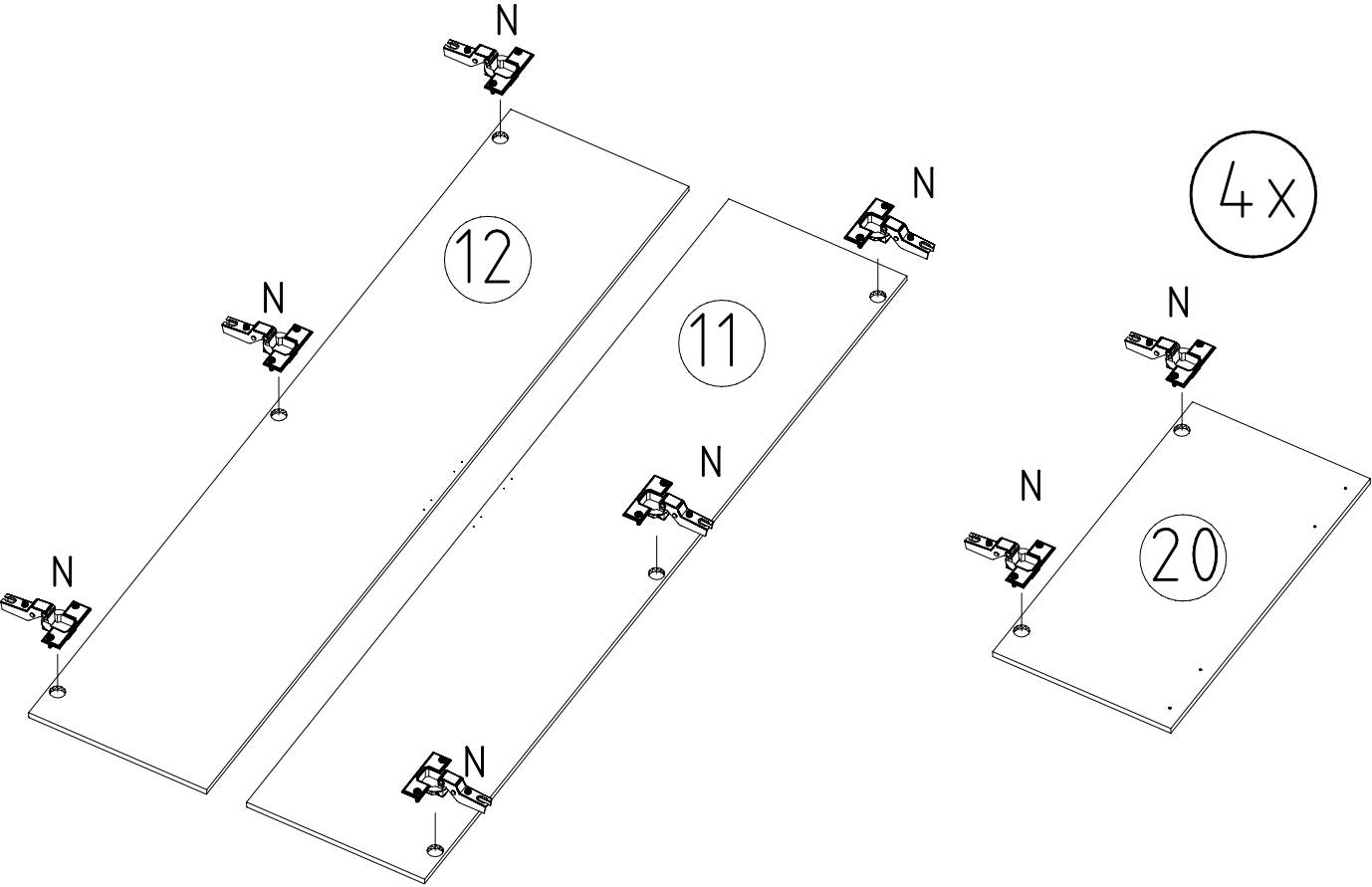
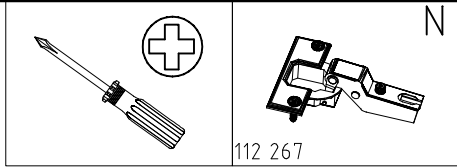

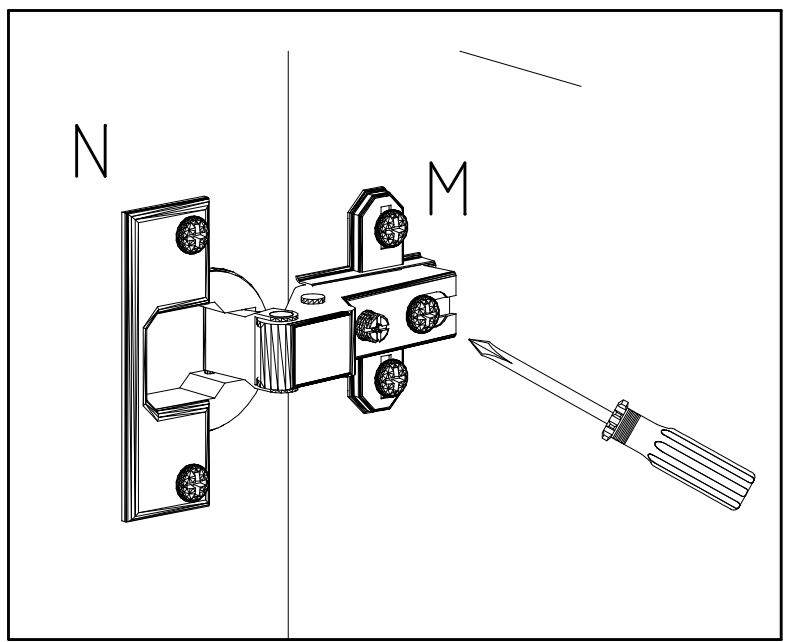
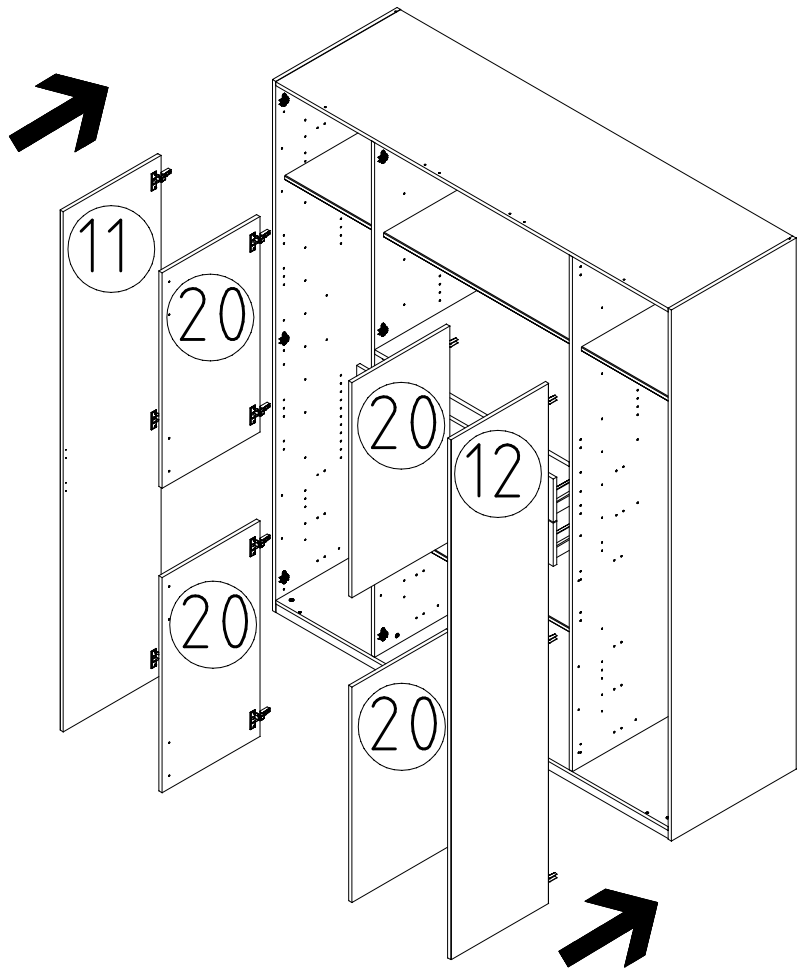
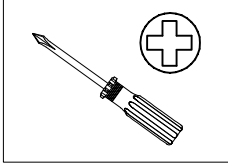

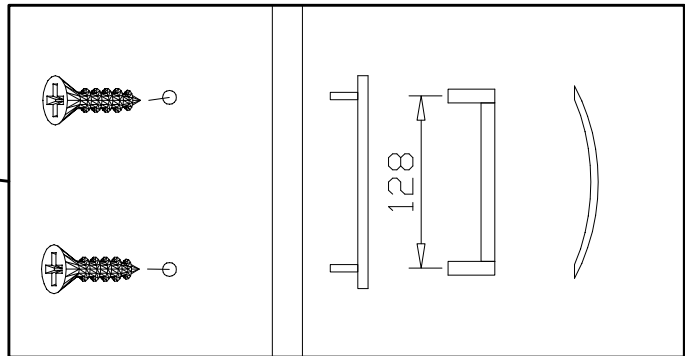
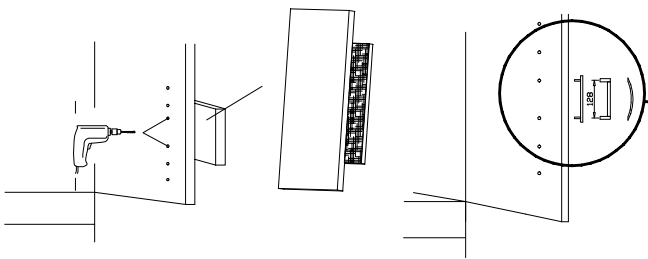
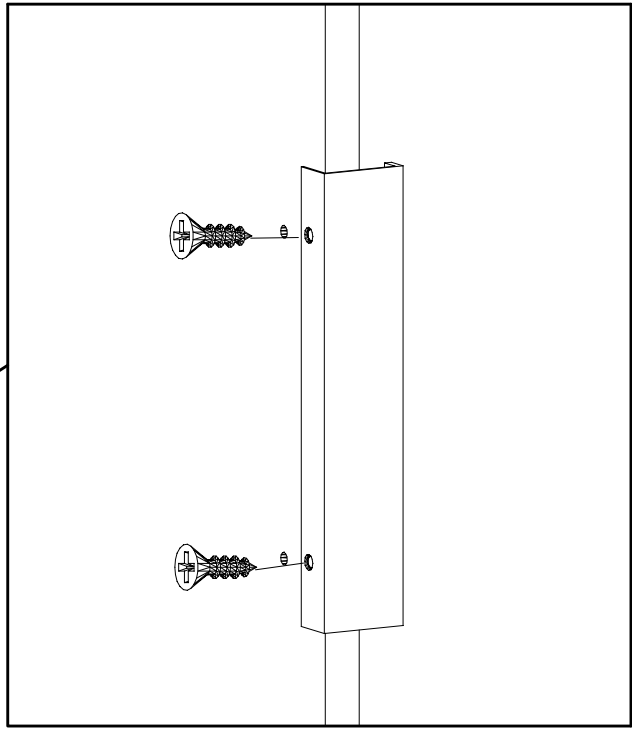
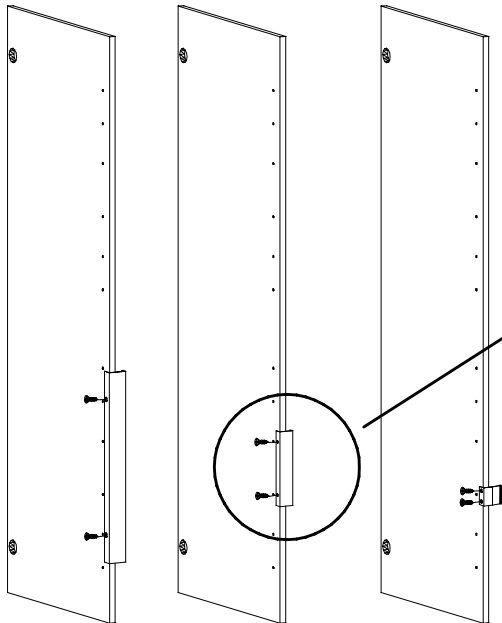
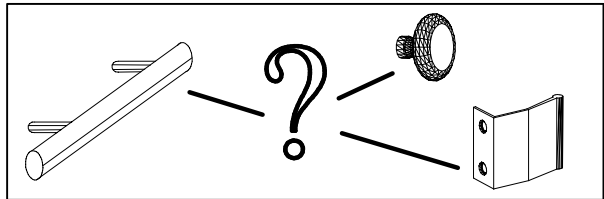
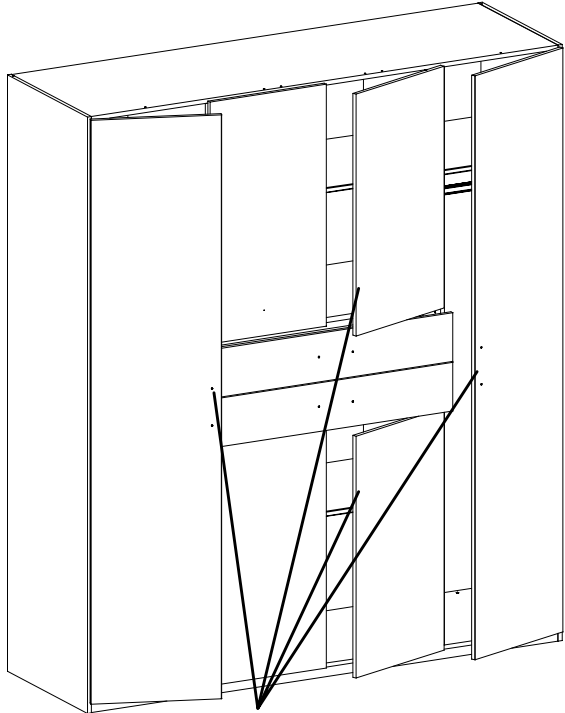
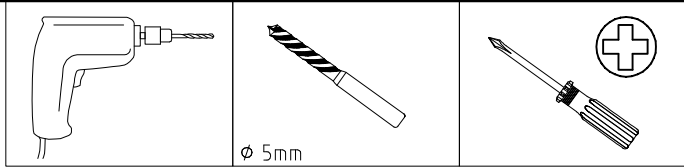

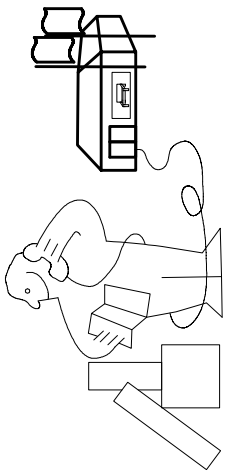
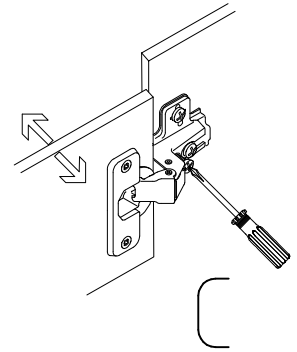
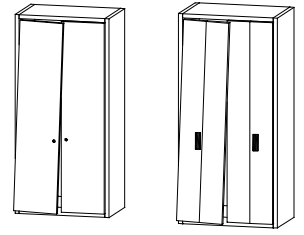
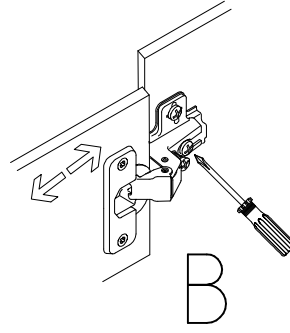
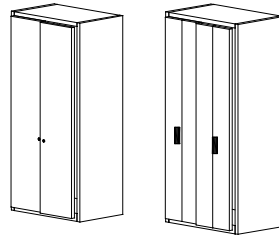
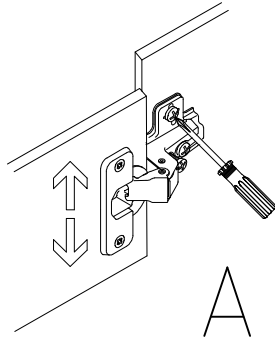
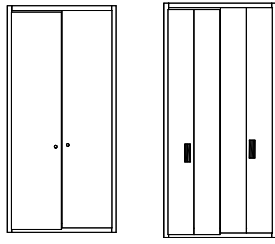
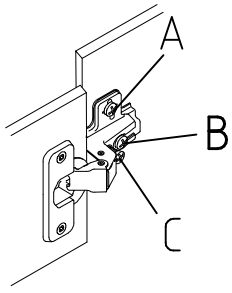

Modell/Modèle/Modèle

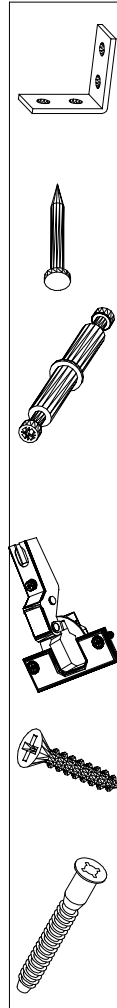
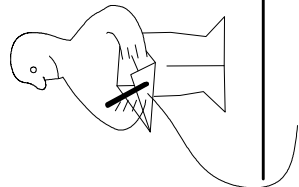
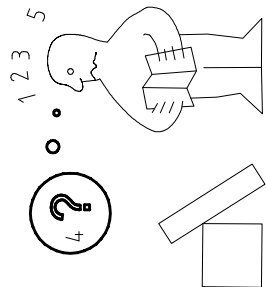
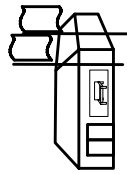
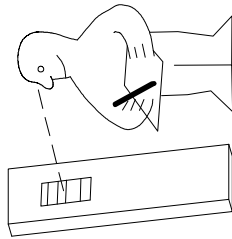

<121 370>	< G 1 >	<4x>

104	23203	30110XY
Kunde Customer client	MAX MUSTERMANN	
Kommission / your order reference / votre reference	3377 MINDEN	
Dekor / Decor / Décor / Modell / Mode / Modèle	F99 SAMPLE	
F99842 SCHWELTUEBENSCHRANK 250 CM H 216CM PLANKENEICHE NB + RAU STEEL PLANKENEICHE NACHBILDUNG	 202320301107 241476000001	
Paket / Package / Paquet	414760	
SOCKEL		
Paket 1 von 8	Colli	Kommission
	10	10
HSP-SWT BOD 50 TEXT/TEX SOCKEL 32 FRESH TV / LT SO-BOD TEXT RASTEX/ ZWBOD D18MM 1X KLSTA		104
Montage - Anleitung	KS-64	Laenge 520,0 Breite 568,0
SOCKEL32 KLEB		



104
 OBEN 5 30/19
 HAUT
 23.08.19
 ROVEN 1 / 1. ABOVE
 OBEN



SAMPLE	23.08.19
Modellname Model	Produktionsdatum Date of manufacture

