

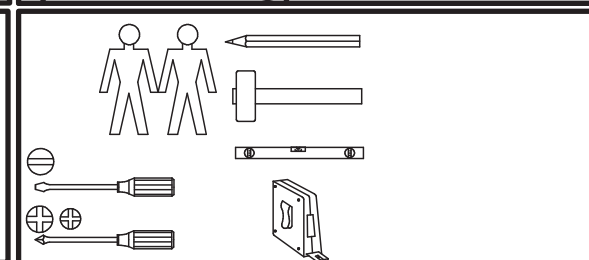

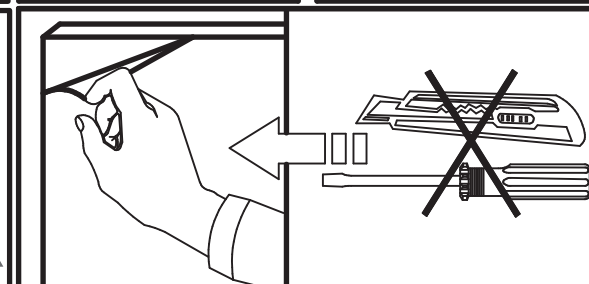

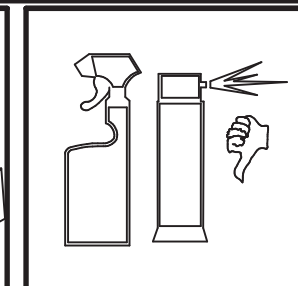

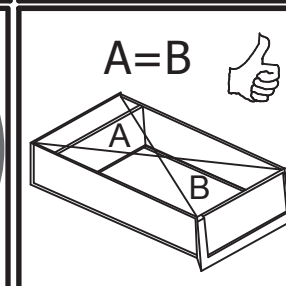

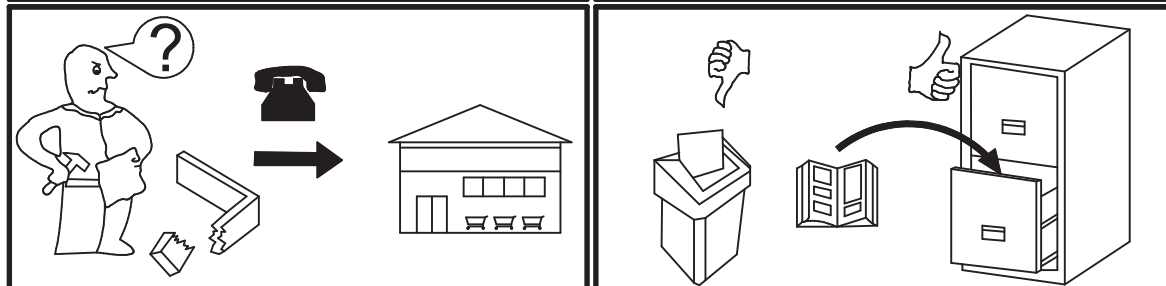
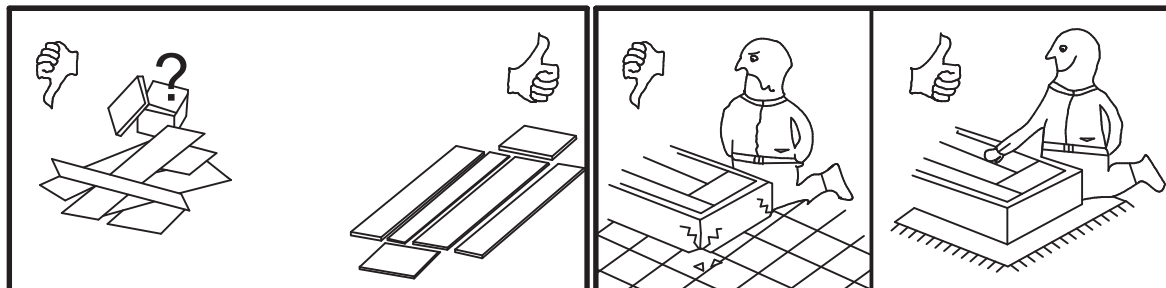
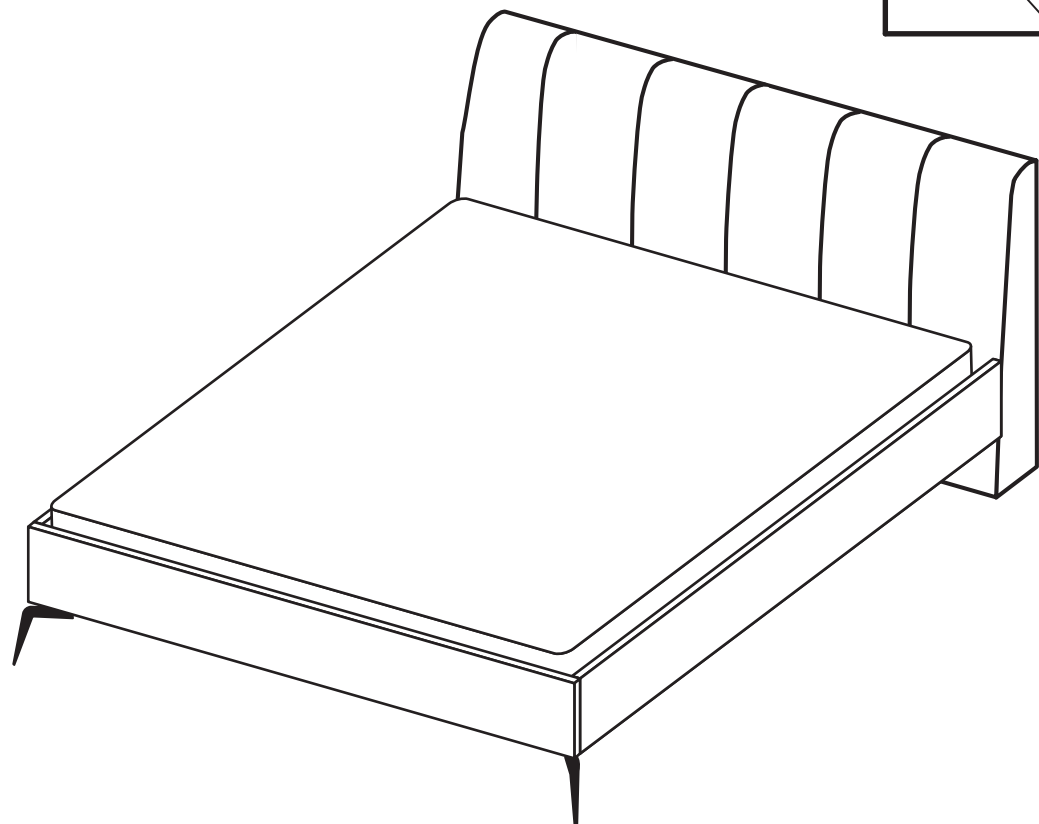
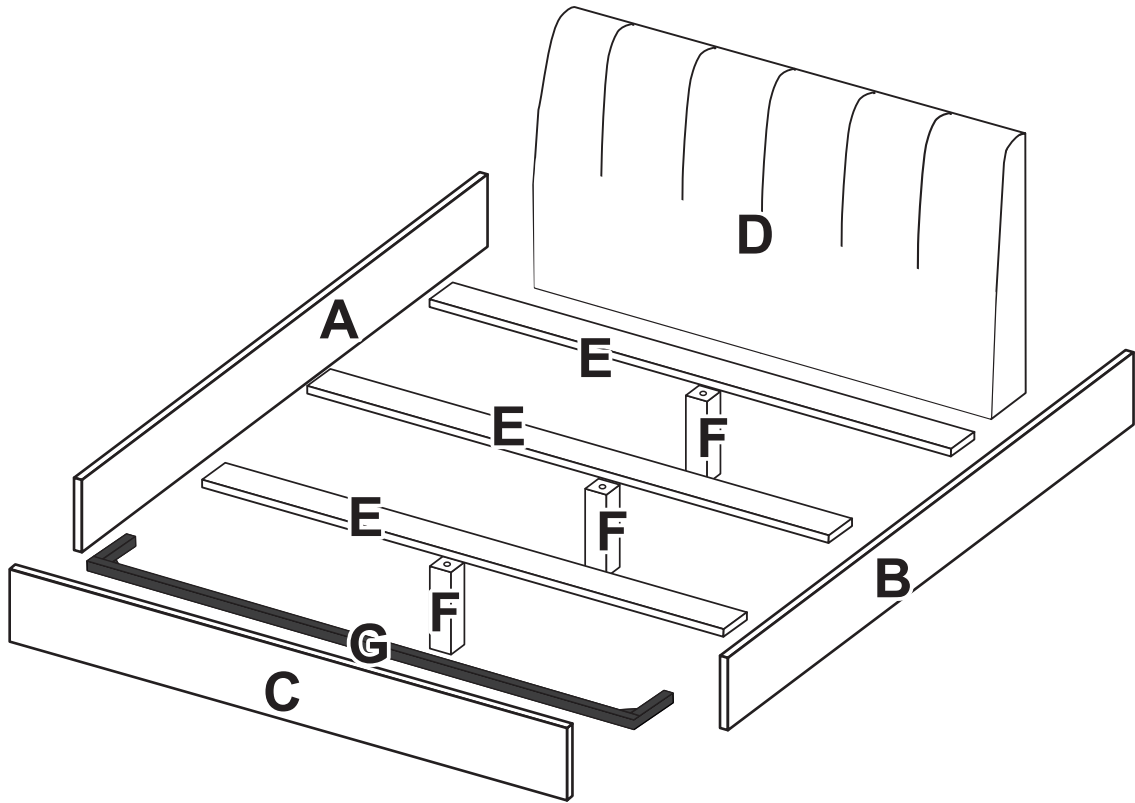

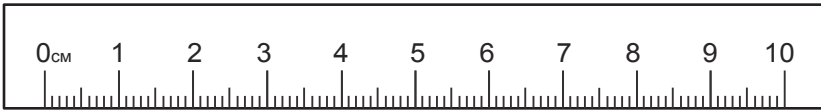

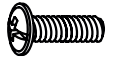
TOFFI
08850014/03

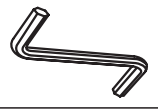
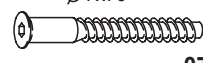
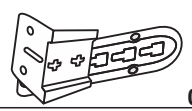
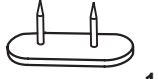

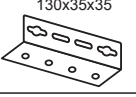





Teil	Maß	St
A	- 2020 x 210 x 16 -	x 1 3/3
B	- 2020 x 210 x 16 -	x 1 3/3
C	- 1910 x 210 x 16 -	x 1 2/3
D	- 1920 x 920 x 16 -	x 1 1/3
E	- 1802 x 70 x 25 -	x 3 3/3
F	- 125 x 50 x 50 -	x 3 3/3
G	- 1816 x 192 x 30 -	x 1 2/3

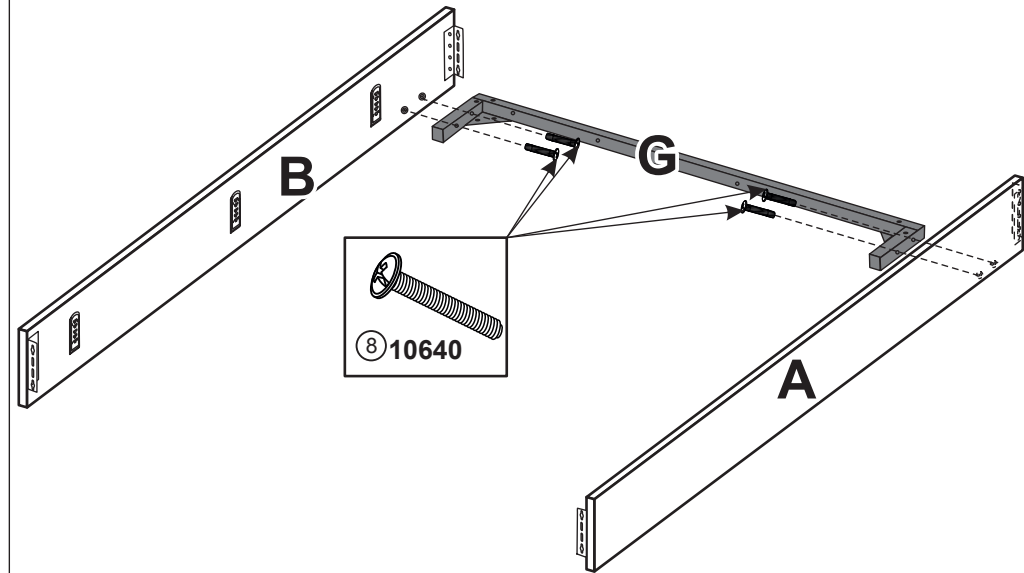
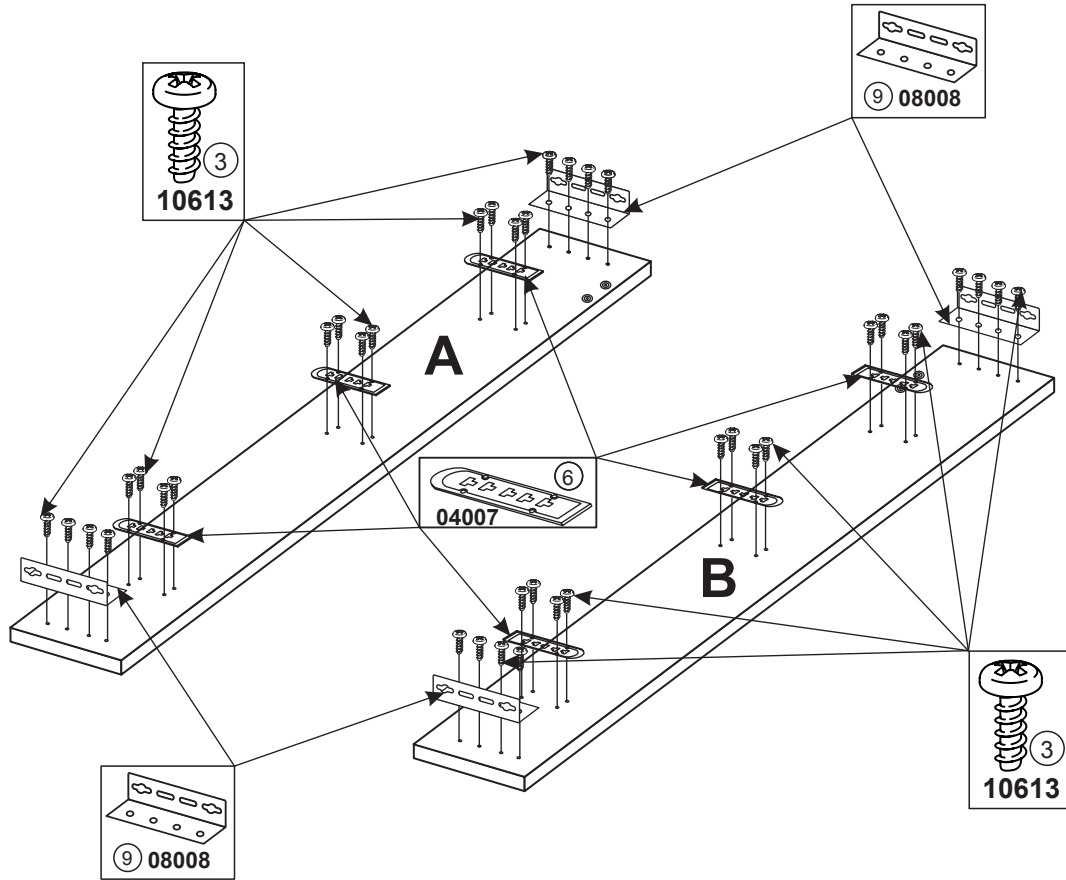

① $\varnothing 6 \times 16$ x4  10616	② M6 x8 Metal  02600	③ $\varnothing 6.3 \times 13$ x56  10613	④  x1 07001	⑤ $\varnothing 7 \times 70$ x6  07770	⑥  x6 04007	⑦  x2 14011
⑧ $\varnothing 6 \times 40$ x12  10640	⑨ 130x35x35 x4  08008	⑩  x2 83747	⑪  x3 14021	⑫  x8 02008	⑬  x9 14016	⑭ $\varnothing 4 \times 16$ x12  10416

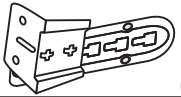

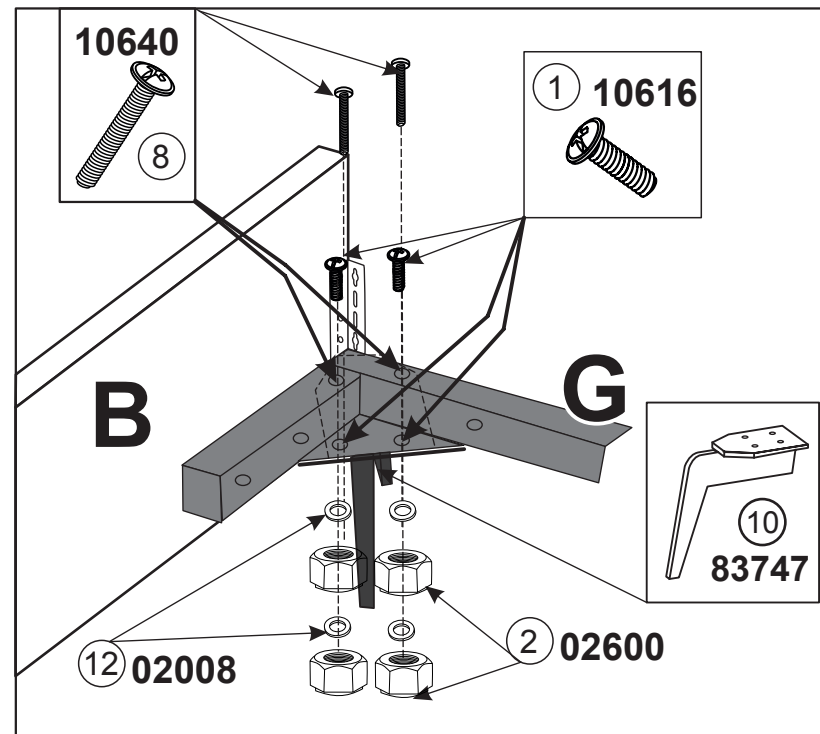
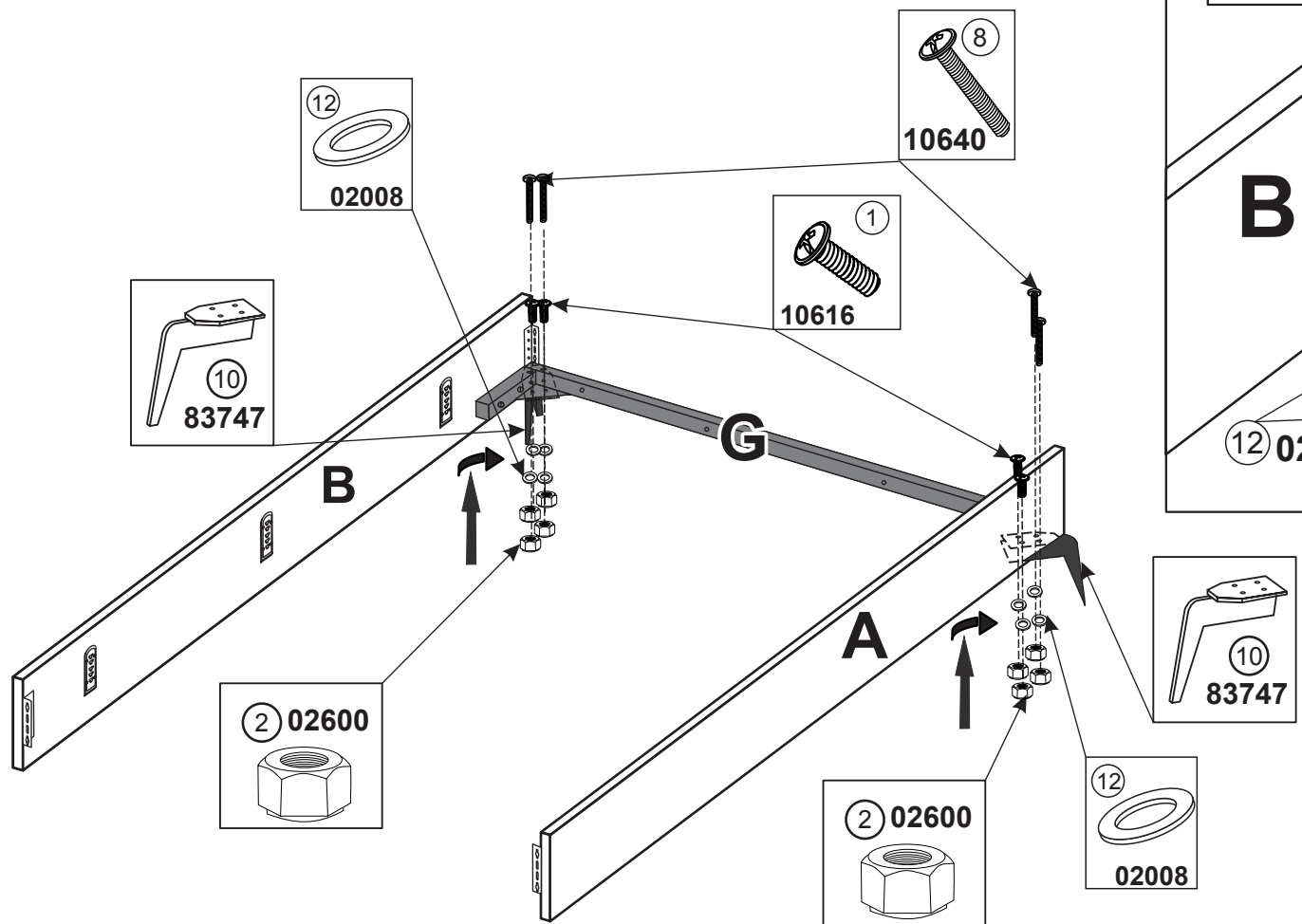

<p>(3) $\varnothing 6.3 \times 13$ x40  10613</p>	<p>(6)  x6 04007</p>	<p>(9) 130x35x35 x4  08008</p>
--	---	--

<p>(8) 6x40 x4  10640</p>



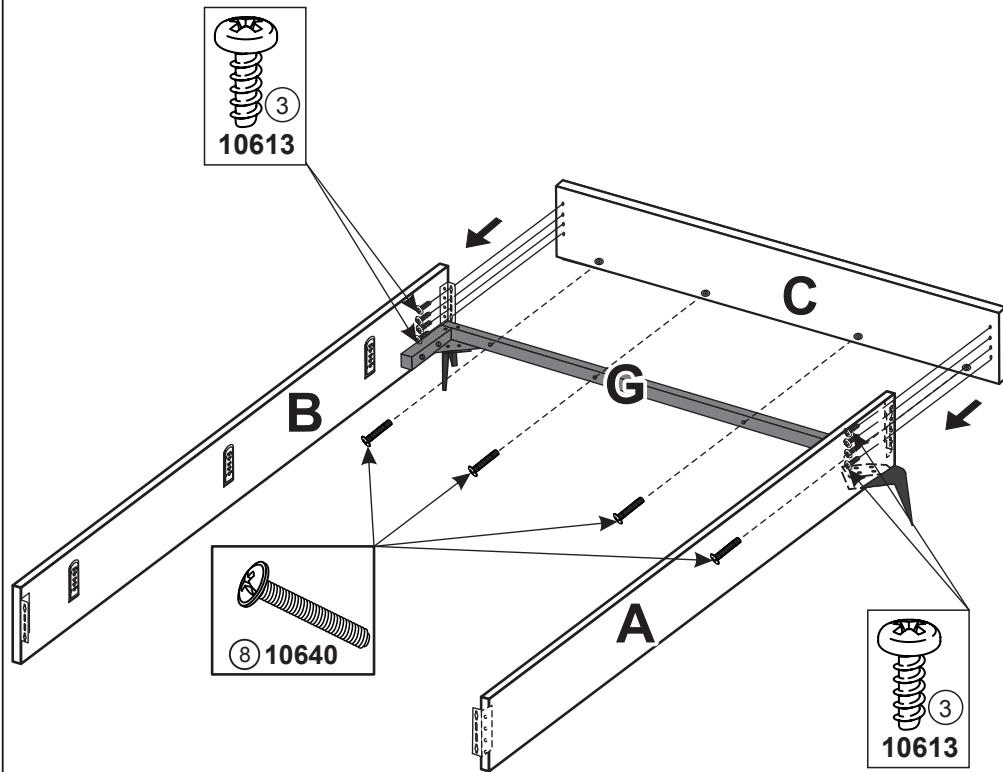

⑩		x2	①	∅6x16	x4	②	M6	x8	⑫		x2	⑧		x4
	83747				10616			02600			02008			10640



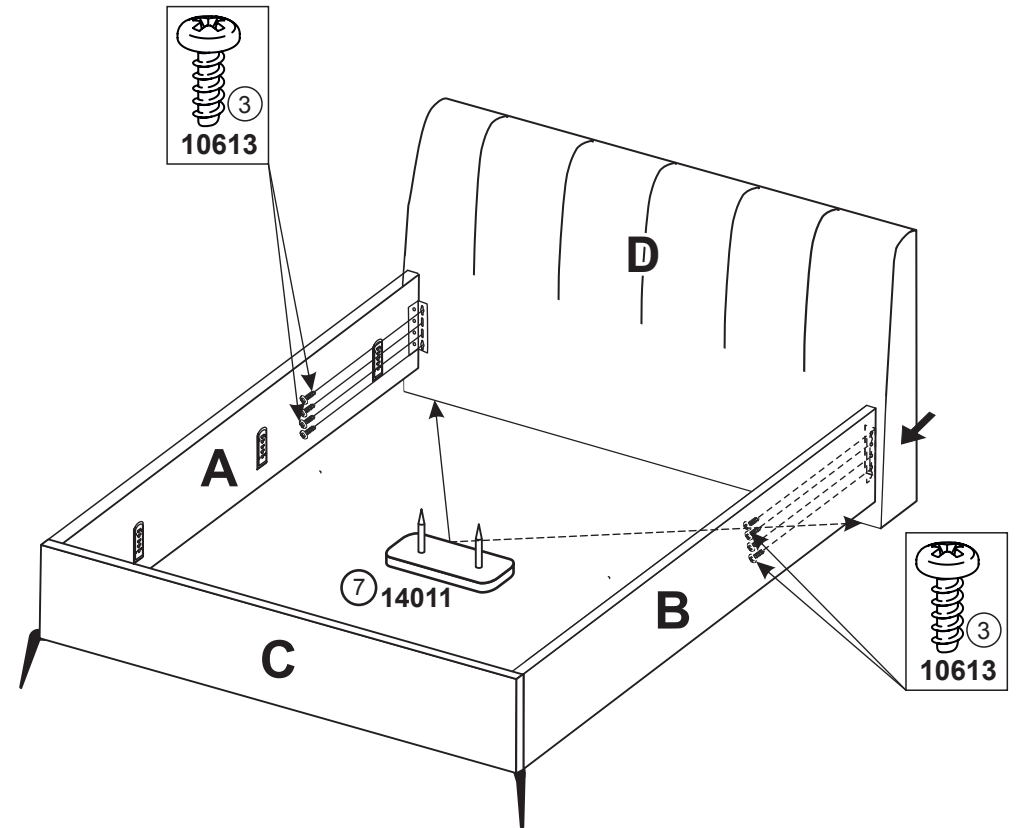

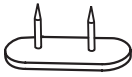

<p>8 6x40 X4</p>  <p>10640</p>	<p>3 Ø6.3x13 X8</p>  <p>10613</p>
---	--

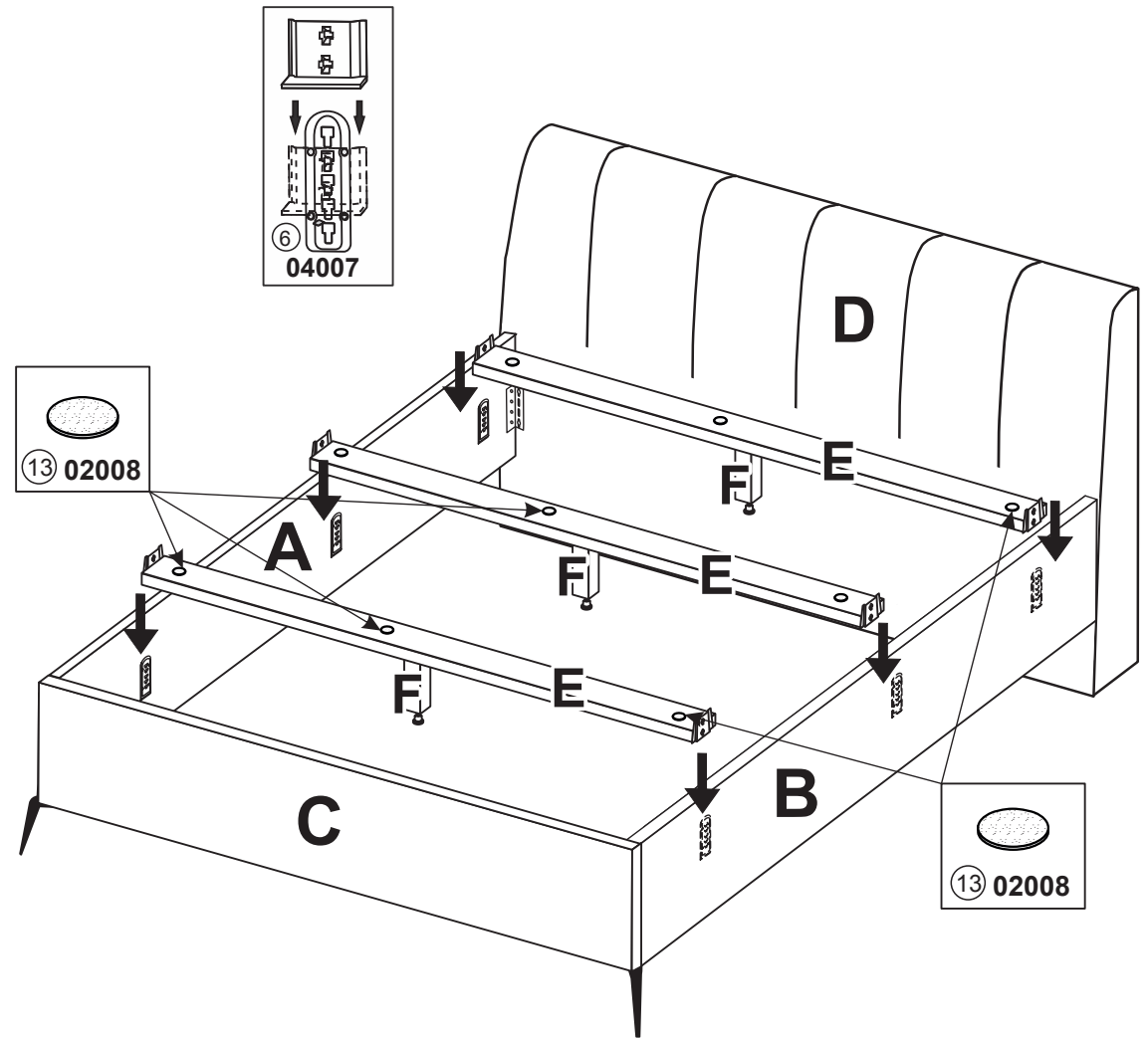
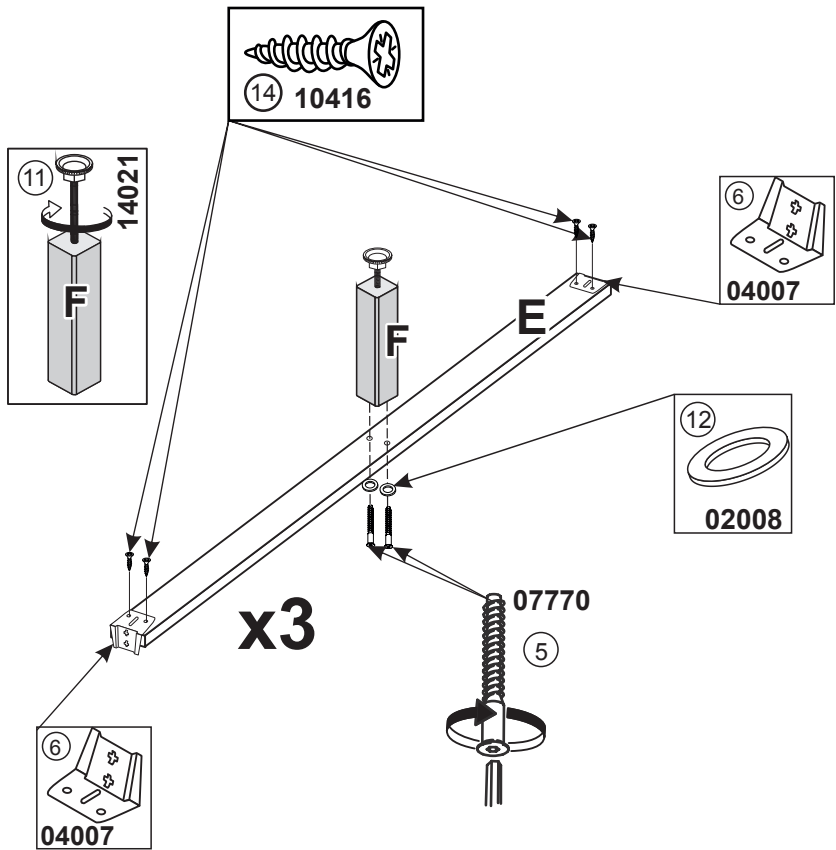

<p>7 X2</p>  <p>14011</p>	<p>3 Ø6.3x13 X8</p>  <p>10613</p>
--	--

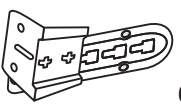

<p>⑤</p> <p>∅ 7x70</p> <p>x6</p>  <p>07770</p>	<p>⑭</p> <p>∅ 4x16</p> <p>x12</p>  <p>10416</p>
--	---

<p>⑪</p> <p>x3</p>  <p>14021</p>	<p>⑫</p> <p>x6</p>  <p>02008</p>	<p>⑥</p> <p>x6</p>  <p>04007</p>
--	--	--

<p>⑬</p> <p>x9</p>  <p>14016</p>
--