

-22_P1

Montageanweisung / Installation instructions / Instruction de montage / Istruzioni di montaggio
montagehandleiding / Instrukcja montażu / Montaj talimatlar / Osszeszerelési útmutató / Návod k montáži /
Návod na montáž / Instrucțiune de montaj / инструкции по сборке / Montaj talimatina / Monteringsanvisningar/
Upute za montažu / Instrucciones de Montaje / Navodila za montažo

RAINBOW

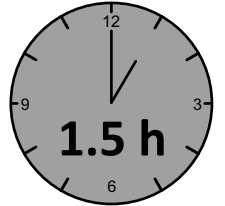
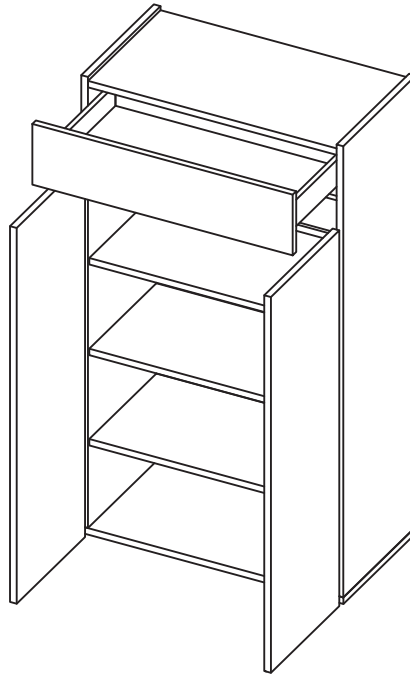
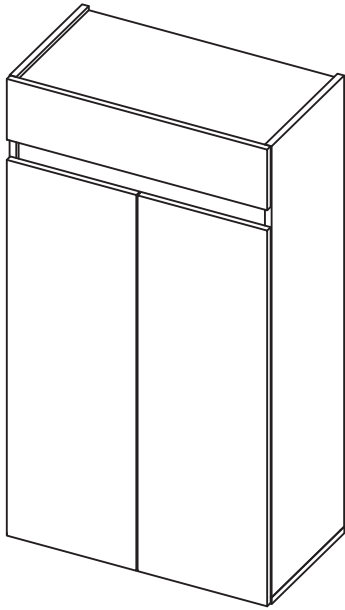
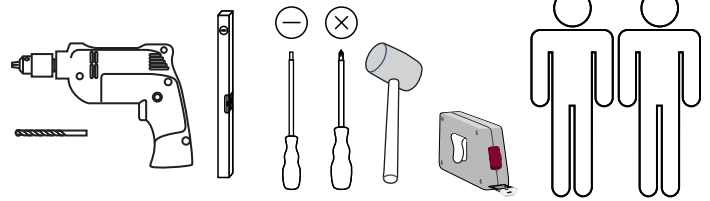

LC S.p.A
Via del Piano s.n
61030 Isola del Piano (PU)
Italia
<http://www.lcmobili.com>

De – bitte lesen sie diese montageanleitung gut durch,
Da wir für fehler, die durch falsche montage entstehen,
Keine haftung übernehmen!

Gb – please read these installation instructions
Through carefully as we cannot accept any liability
For faults occurring as a result of incorrect installation!

Cz – přečtěte si prosim pozorně tento návod k montáži,
Aby jste předešli chybám vzniklých špatnou montáží,
Za které neručíme!

Fr – veuillez lire attentivement cette notice de montage,
Car nous déclinons toute responsabilité en cas d'erreurs
Découlant d'un montage erroné !

It – prego leggere attentamente le istruzioni per il montaggio,
Poiché decliniamo qualsiasi responsabilità
Per difetti derivanti da montaggio errato.

Se - läs monteringsanvisningarna noggrant.
Vi avsäger oss allt ansvar för defekter som
Uppstår p.g.a. Felaktig montering.

Rs – pažljivo pročitajte upute za montažu,
Jer otklanjamo svaku odgovornost za pogreške
Nastale uslijed pogrešne montaže.

Sl – prosimo, da pazorno preberete navodila za montažo,
Saj zavračamo vsakršno odgovornost za napake,
Ki bi nastale zaradi napačne montaže.

Pt – leia atentamente as instruções de montagem, uma vez
que não assumimos qualquer responsabilidade por defeitos
resultantes de uma montagem incorrecta.

Nl – leest u alstublieft deze montagehandleiding goed door,
Voor fouten door verkeerde montage zijn wij niet verantwoordelijk.

Pl – prosze uwaznie zapoznac sie z instrukcja montazu,
Poniewaz nie ponosimy odpowiedzialnosci za niewlasciwy montaz.

Hu – Kérjük, olvassa el figyelmesen
ezt az összeszerelési útmutatót,
mert a helytelen összeszerelésből
a dódó hibákért nem vállalunk felelősséget!

Sk – Prosime, dobre prečítajte si tento návod na montáž,
pretože nepreberáme žiadne ruèenie za chyby,
ktoré vzniknú na základe chybnej montáže!

Ro – Vă rugăm să cititi cu atenție aceste instrucțiuni
de montaj deoarece nu preluăm garanția pentru defecte
ce apar datorită unui montaj incorrect!

Ru – Пожалуйста, внимательно ознакомьтесь ù
с данной инструкцией по монтажу, поскольку мы не
несем ответственности за ошибки, причиной которых
является неправильный монтаж.

Tr – İlkonce kullanma klavuzunu iyi okuyun,
yalnis montaj yapasaniz bunun sorumlusu biz degiliz.

Es – Se ruega leer con atención las instrucciones
de montaje debido a que declinamos cualquier
responsabilidad
por defectos derivados de un montaje erróneo.

RAINBOW



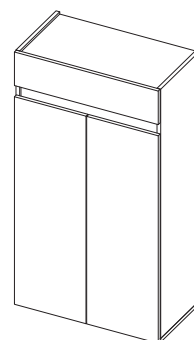
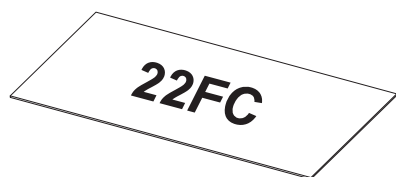
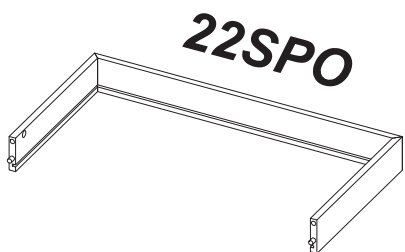
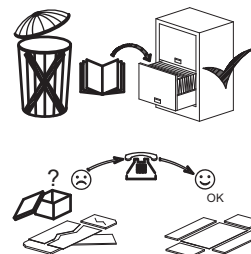

22FS

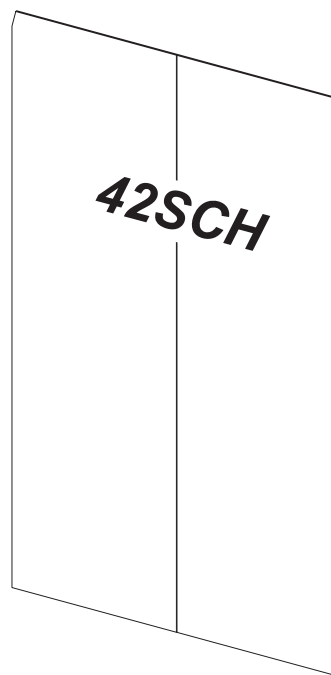
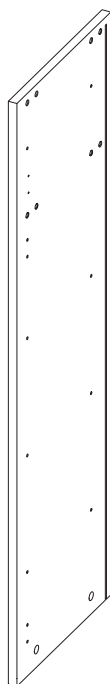

22FD



22CI	595x328.5x16 mm	1	1/2
04FO	628x328.5x16 mm	1	1/2
22FAI	595x80x16 mm	1	1/2
22RI	595x309x16 mm	1	1/2
42PI	595x304x16 mm	3	1/2
22FS	1114x329x16 mm	1	1/2
22FD	1114x329x16 mm	1	1/2
42SCH	1103x610x3 mm	1	1/2
22SPO	300x570x64 mm	1	2/2
22FC	557x301x3 mm	1	2/2
22CA	623x150x16 mm	1	2/2
22SP	928x310x16 mm	2	2/2

ONDERDELEN LYST-SERVICEKARTE-FORMULAIRE DEMANDES SAV-SPAREPARTS LIST-SCHEDADI SERVIZIO

BESLAG-BESCHLAEGE - QUINCALLERIE - HARDWARE - FERRAMENTA

SERVICEKARTE

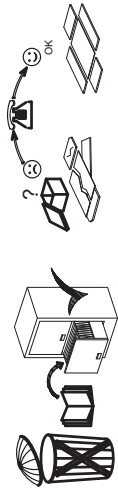

COS

x4

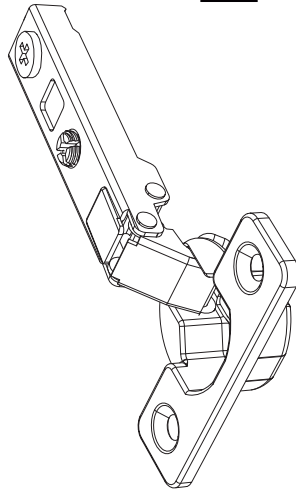

H2E

x4

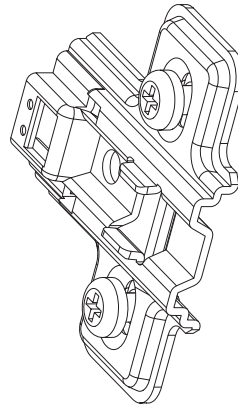

V415 x8

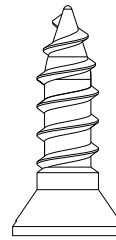

Ø4x15 mm

FL

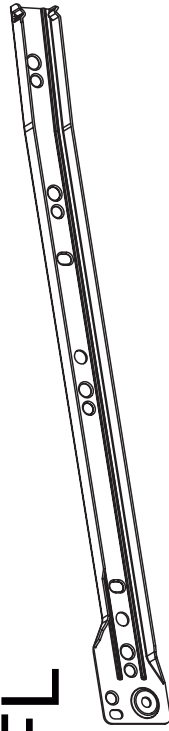

FR

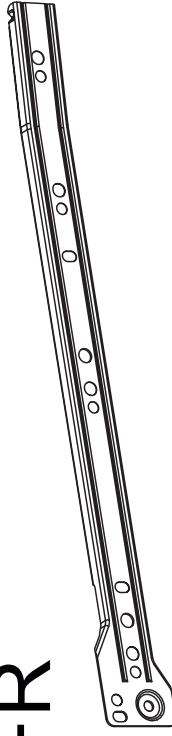

ML

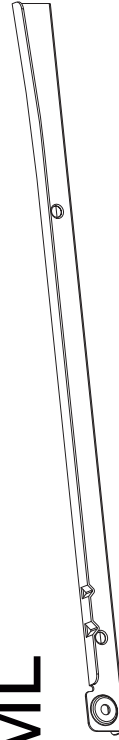

MR

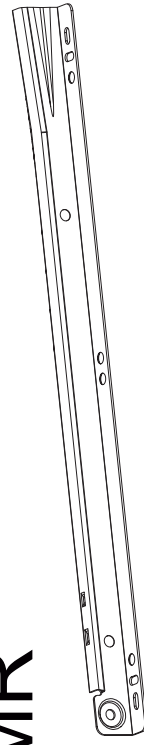

ONDERDELEN LYST-SERVICEKARTE-FORMULAIRE DEMANDES SAV-SPAREPARTS LIST-SCHEDADI SERVIZIO

BESLAG-BESCHLAEGE - QUINCALLERIE - HARDWARE - FERRAMENTA

V418 x2

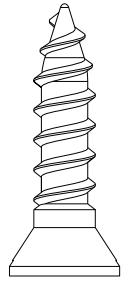

Ø4x18 mm

B

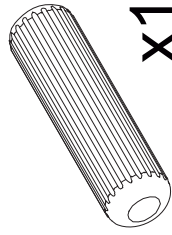

x12

C

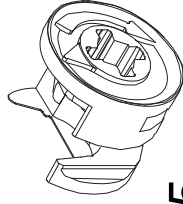

Ø15

x12

D

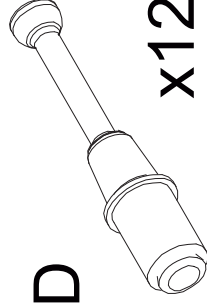

x12

M11

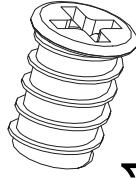

Ø6x11

x4

V3516 x4

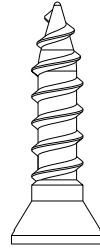

Ø3.5x16 mm

F

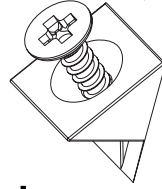

x14

R

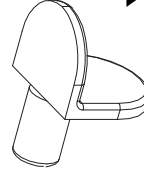

x12

T20



Ø20

x8

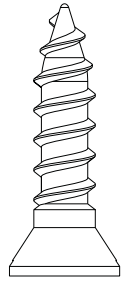

CH

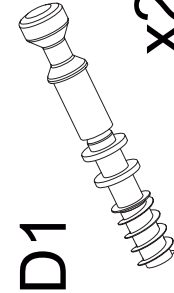

x2

x5

C1

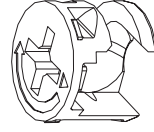

Ø12

x2

D1

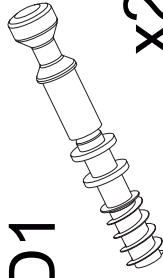

x2

V3540 x4

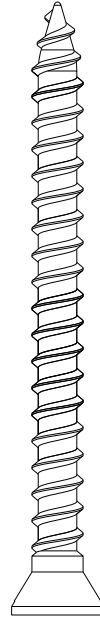

Ø3.5x40 mm

PST

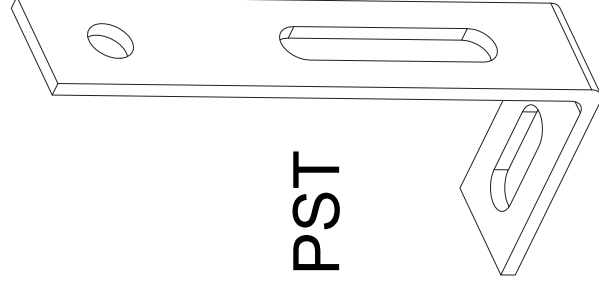

1

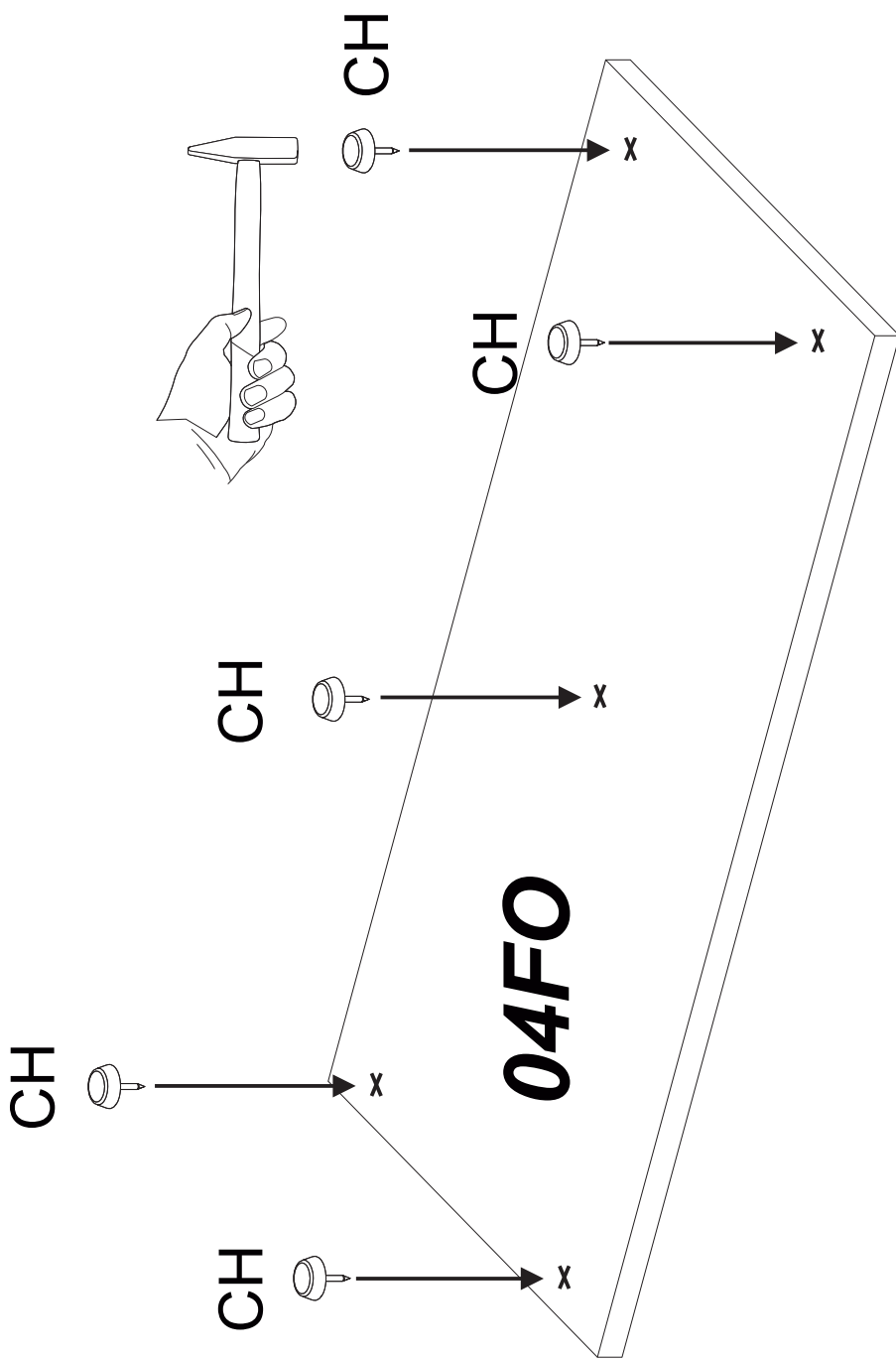
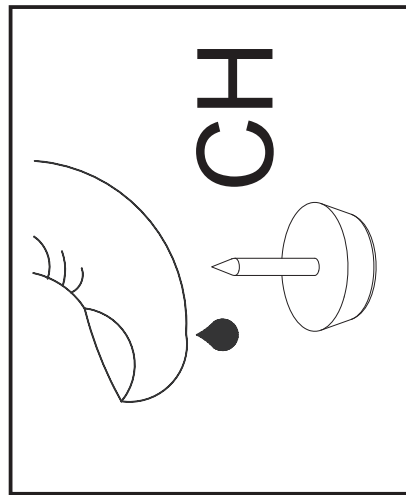
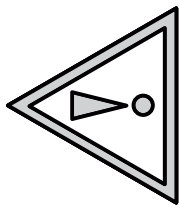
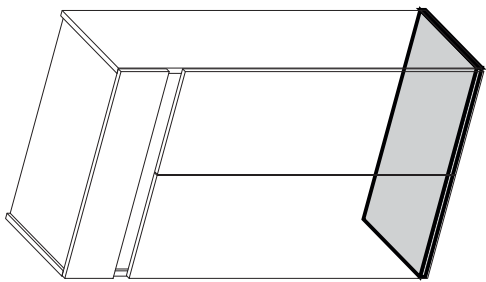
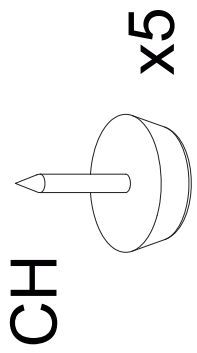
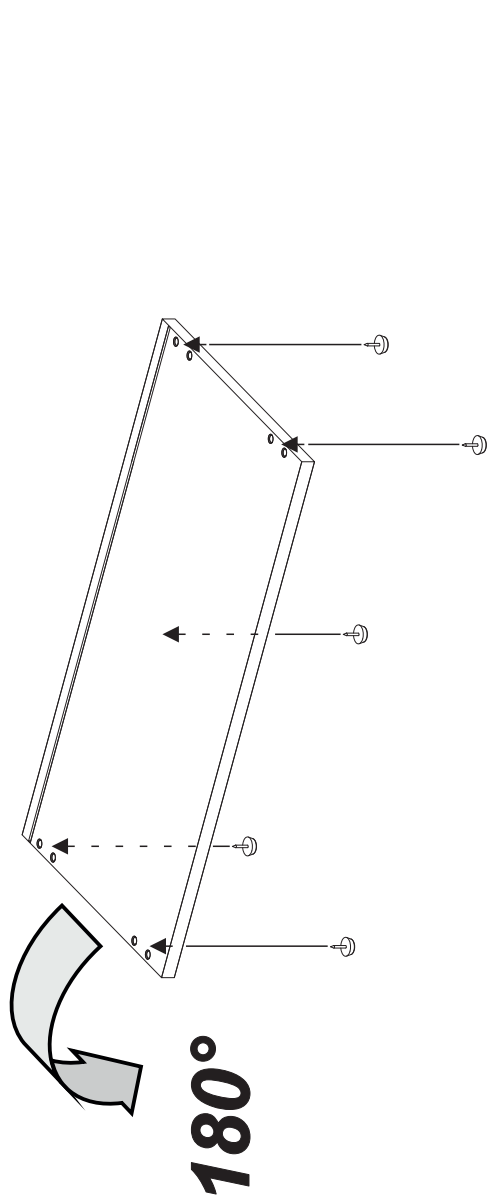

2

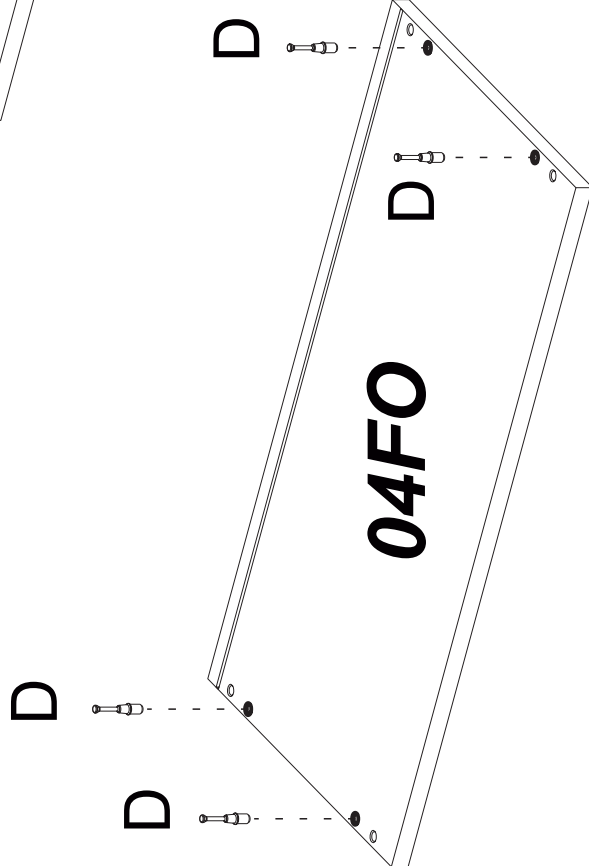
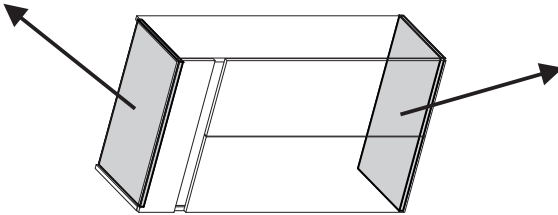
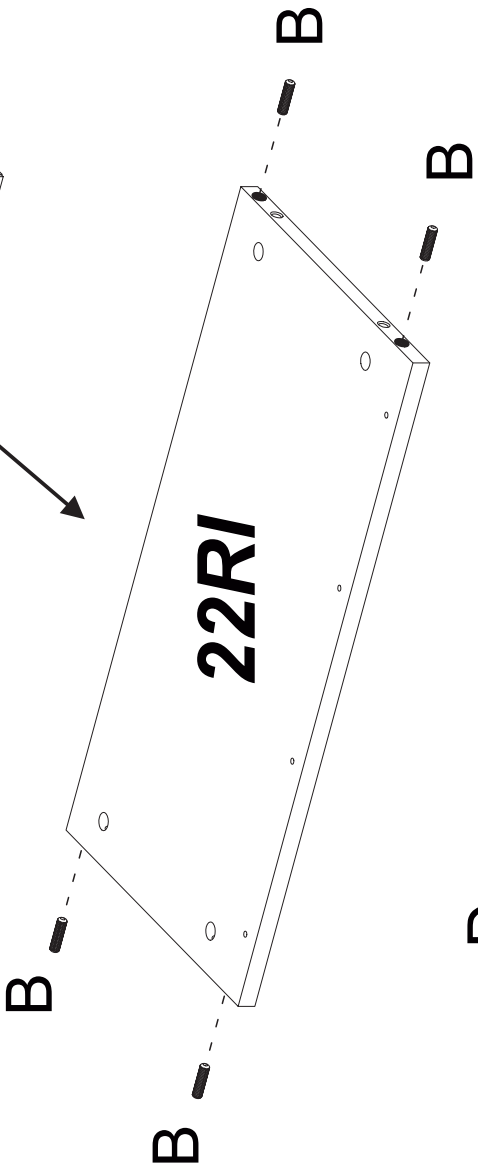
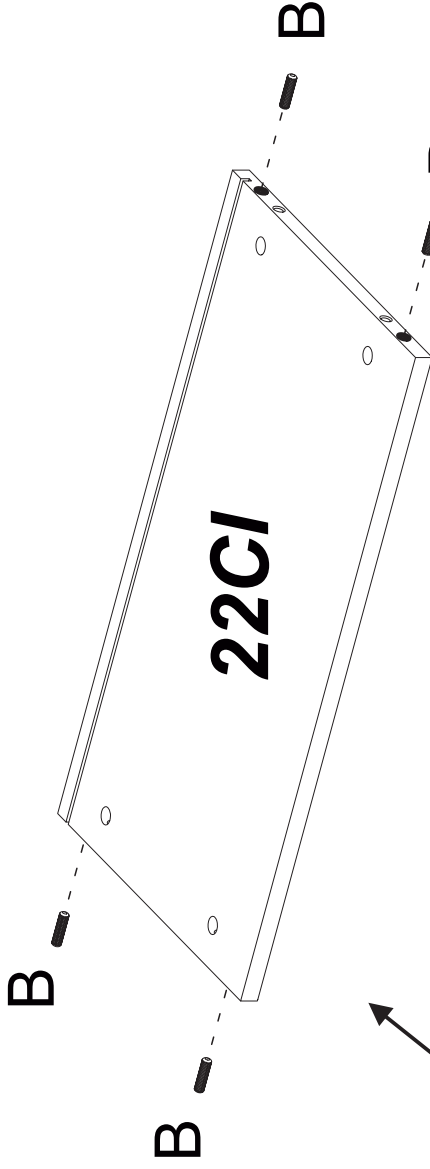
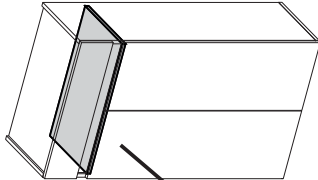
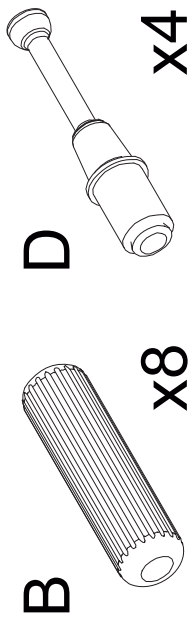

3

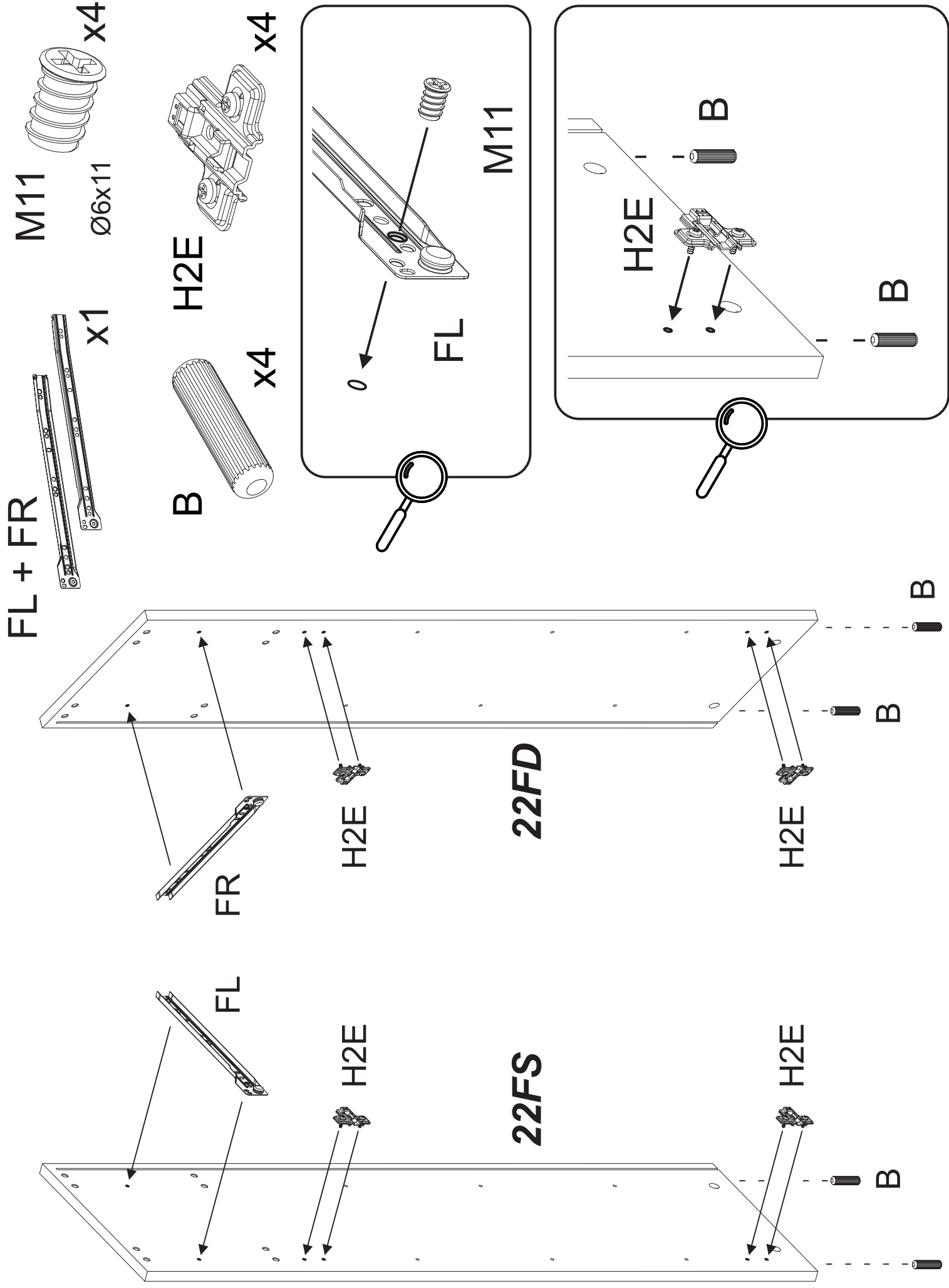

4

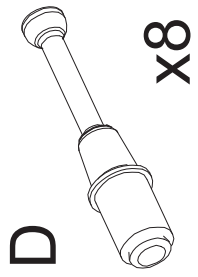

x8

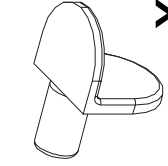

x12

R

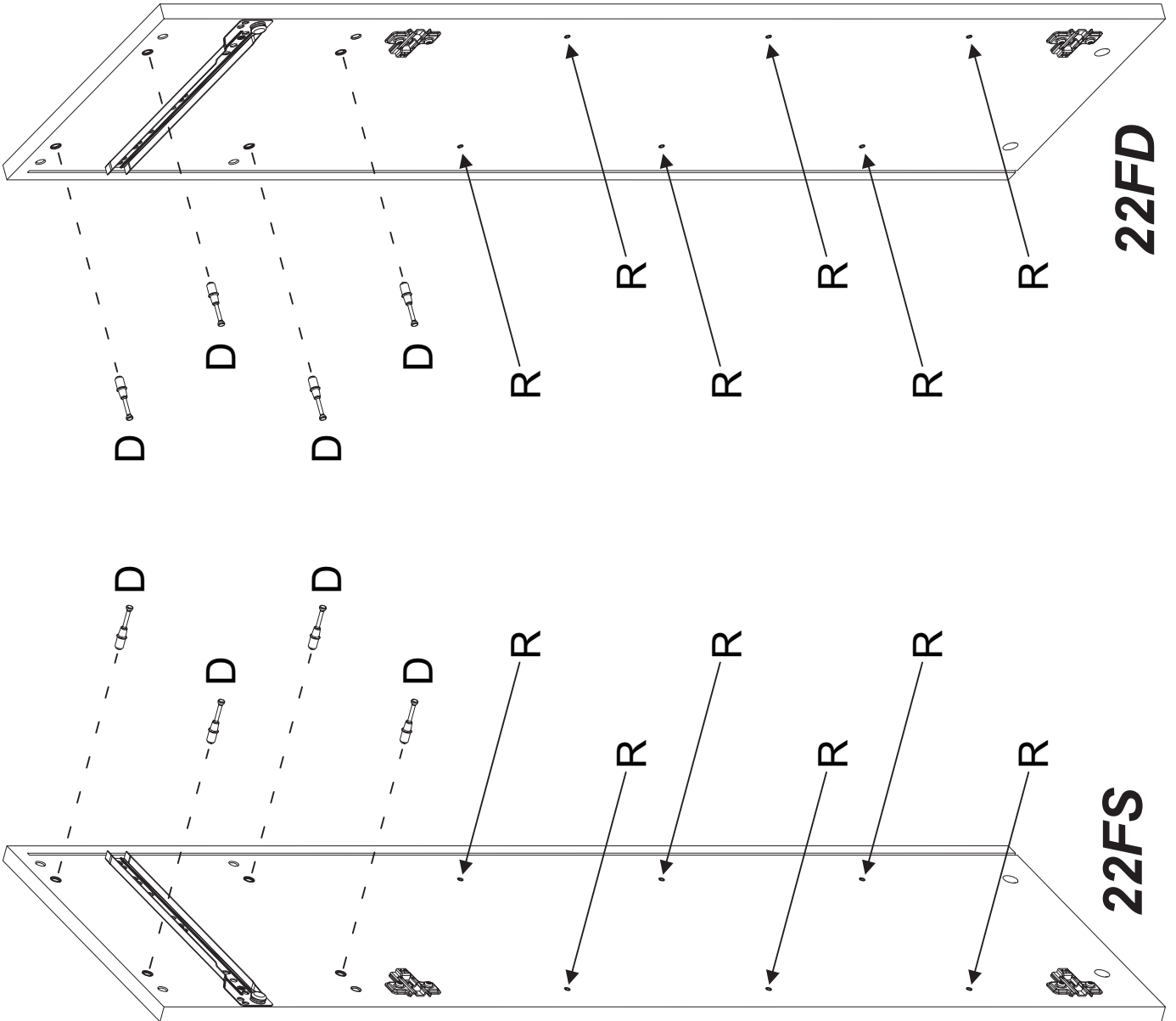
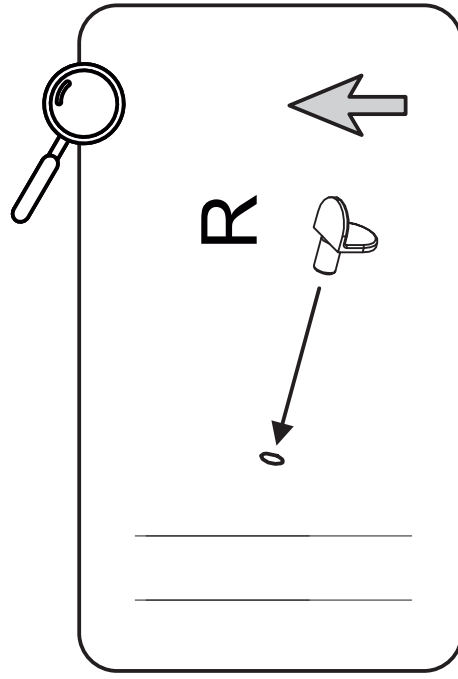

22FD

22FS

5

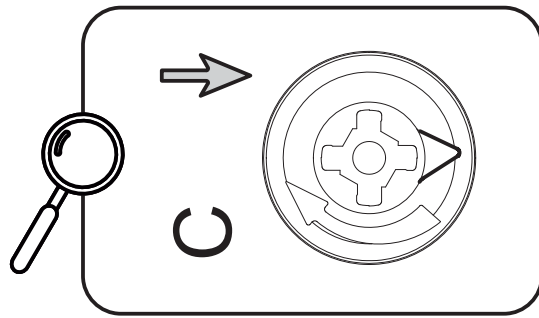
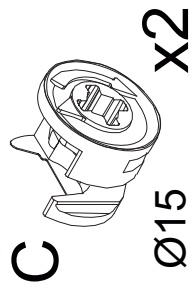
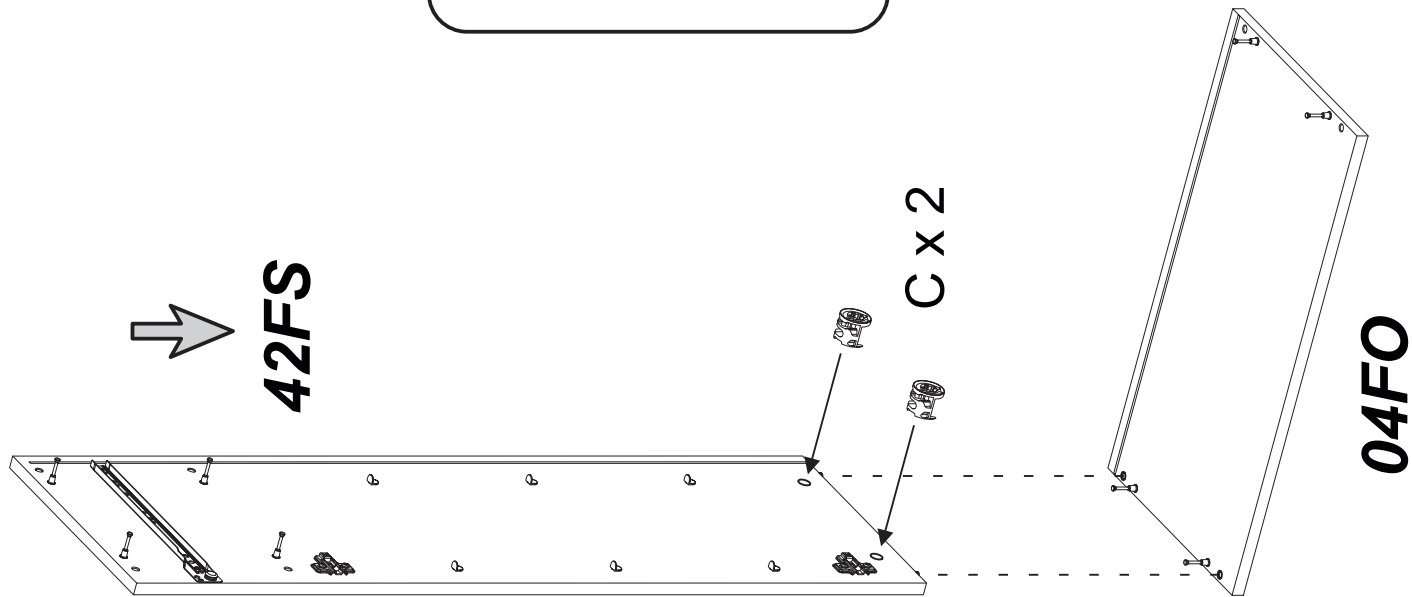

6

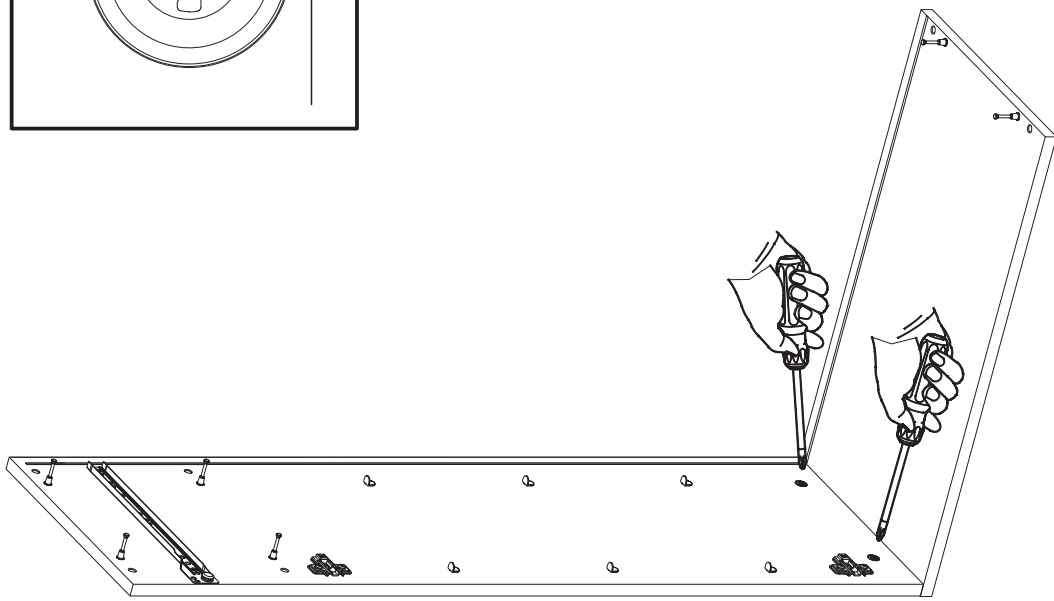
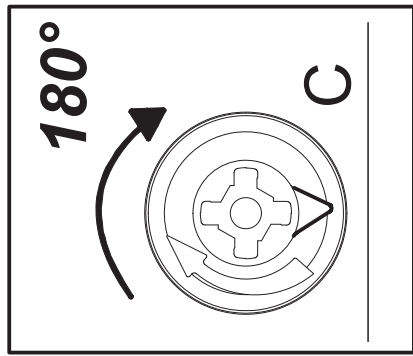
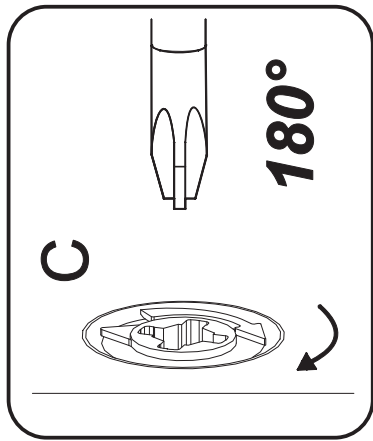

7

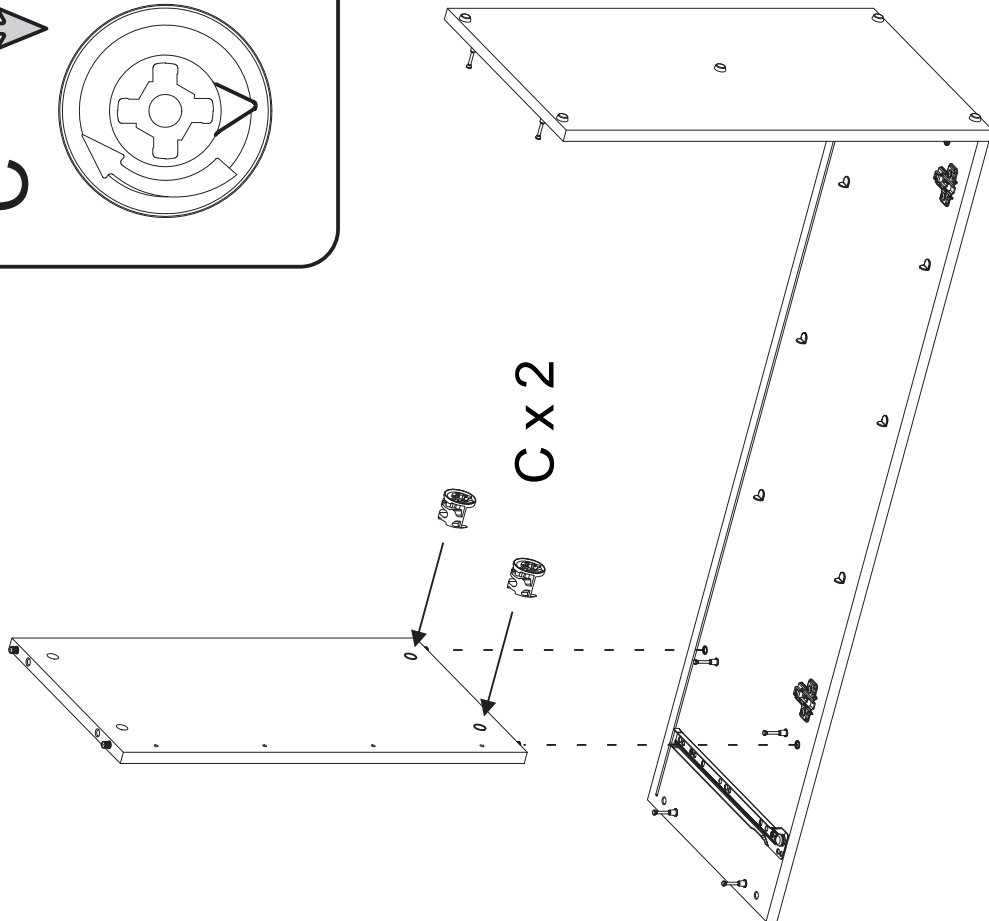
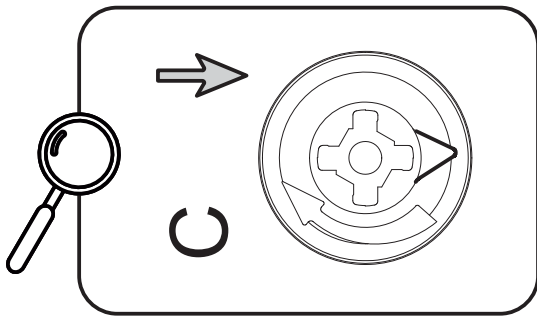
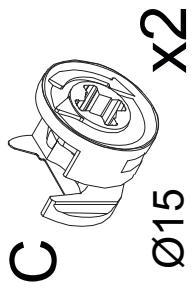
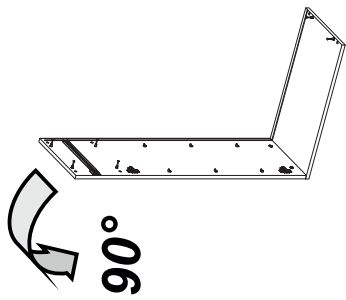

8

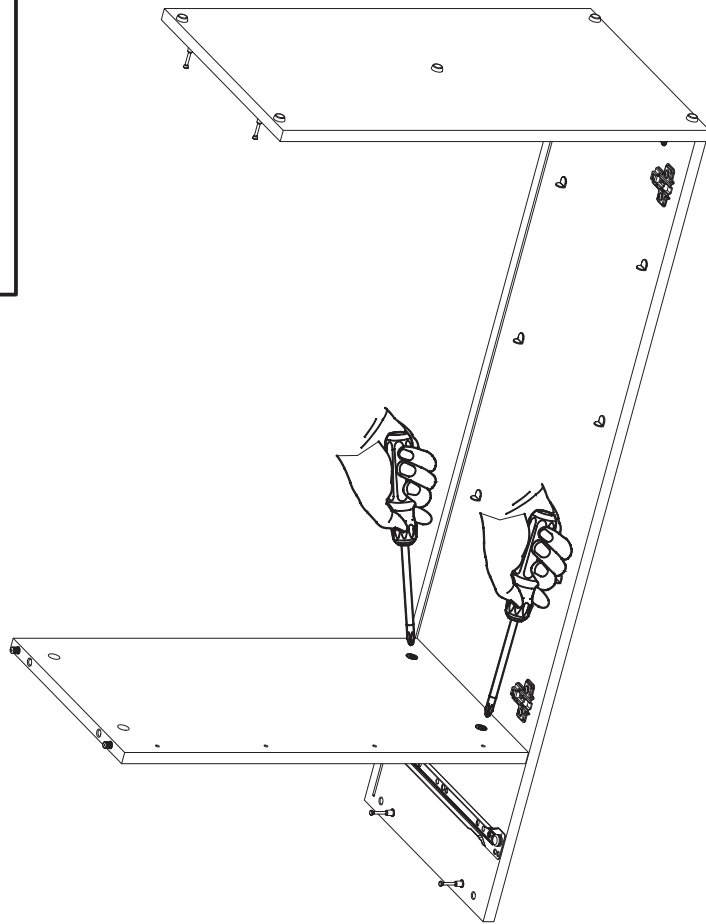
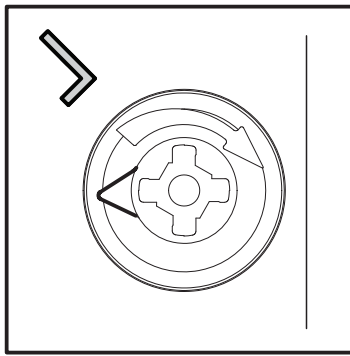
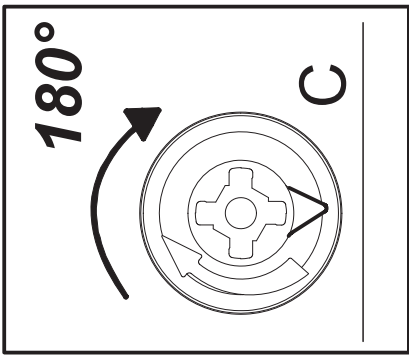
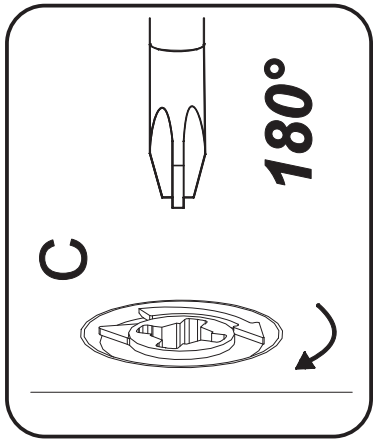

9

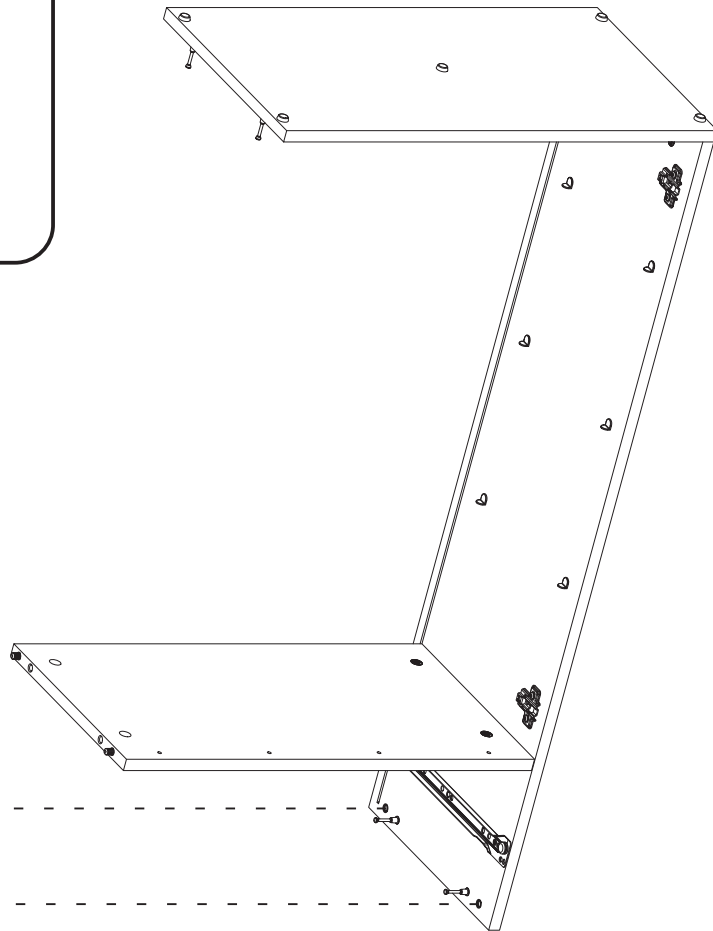
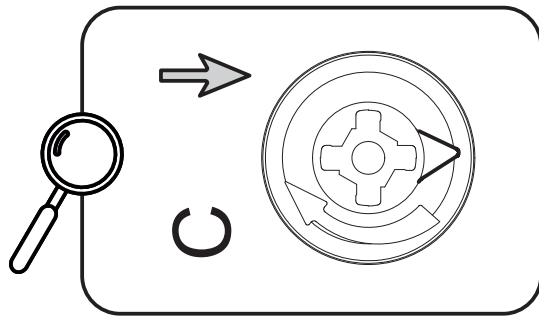
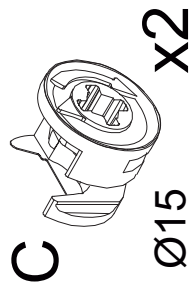
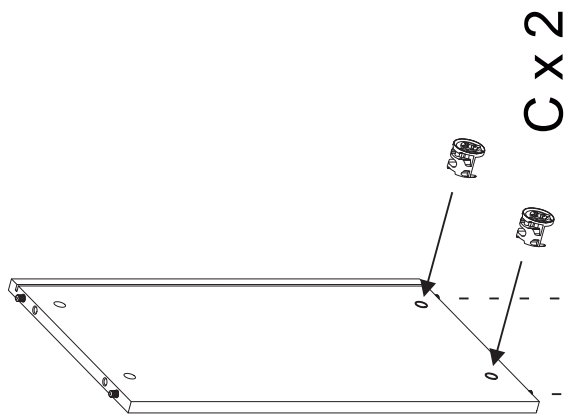

10

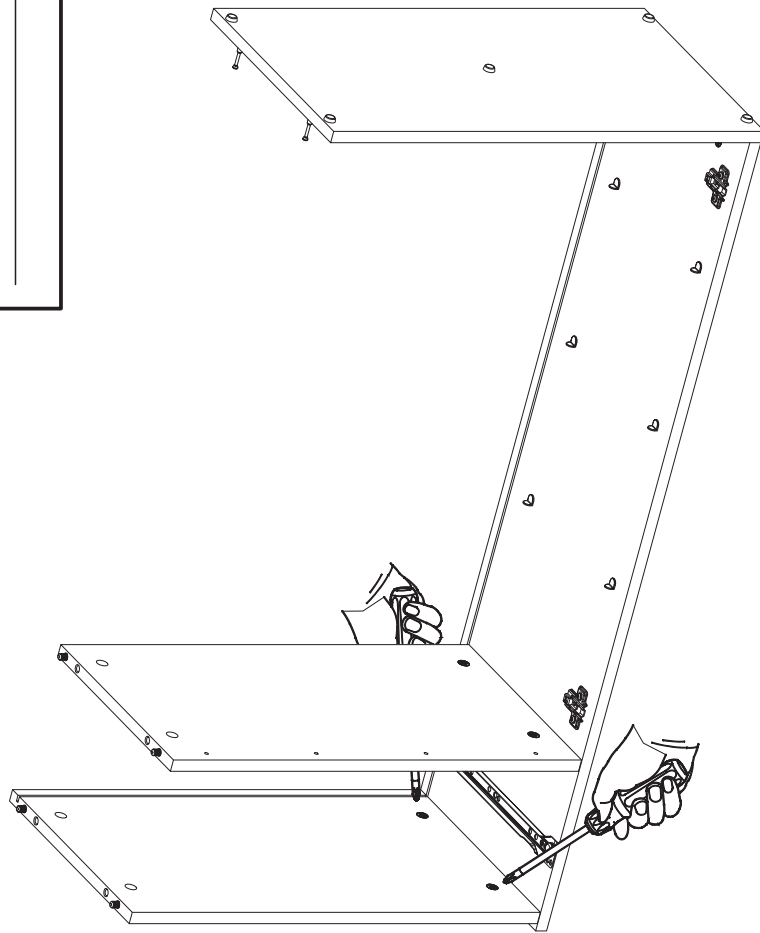
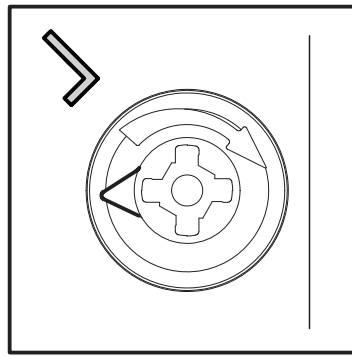
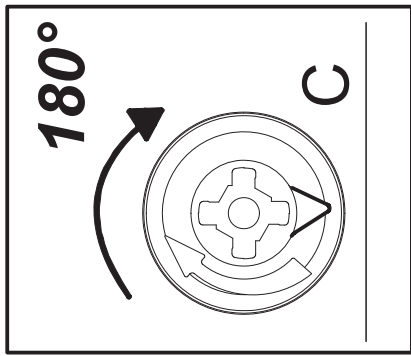
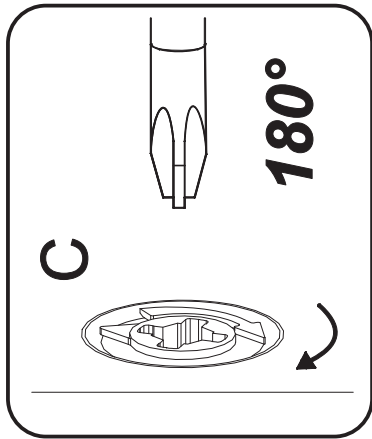

11

180°

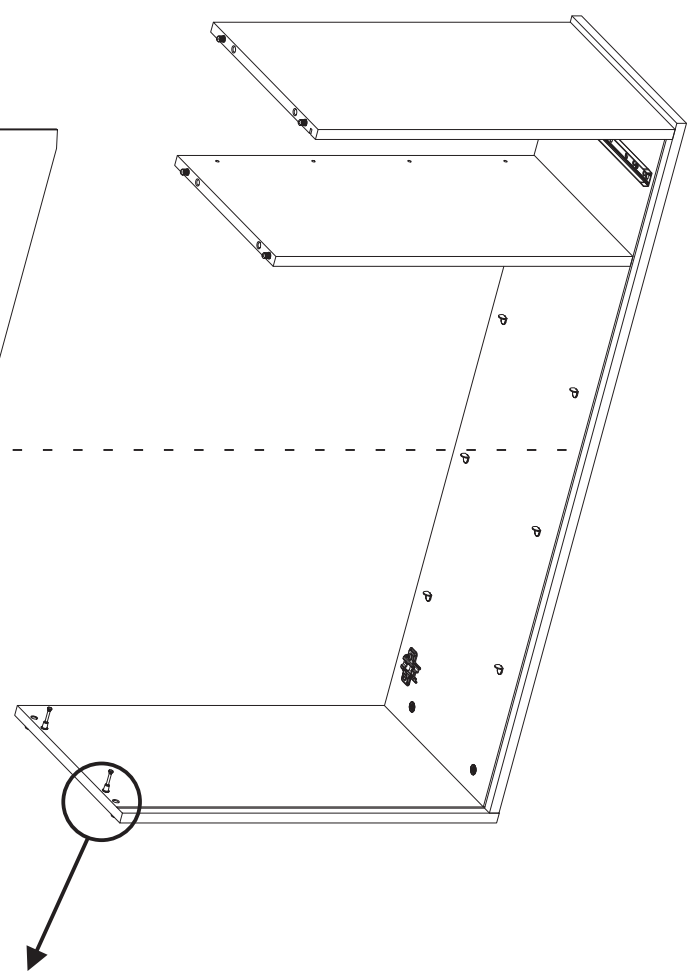
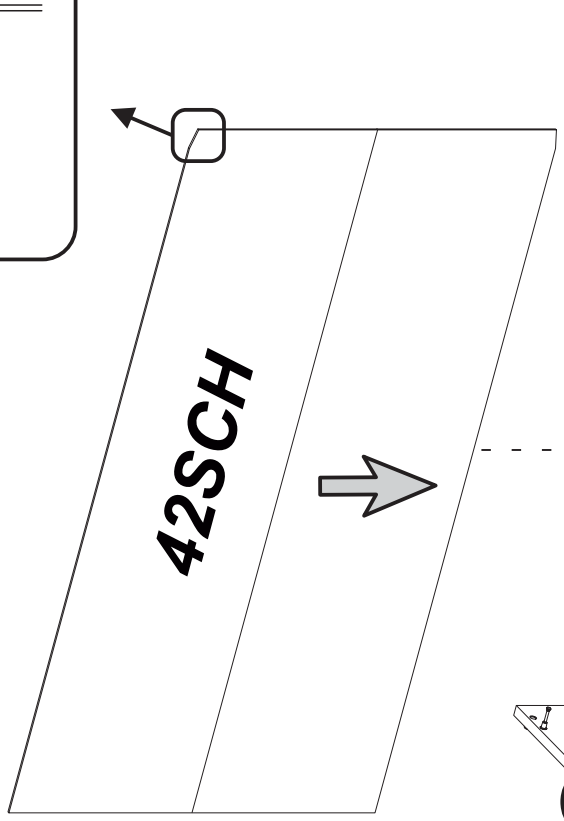
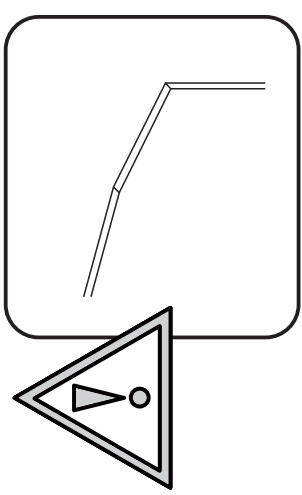
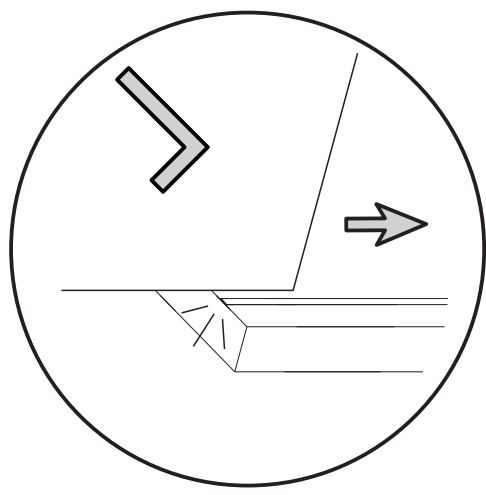
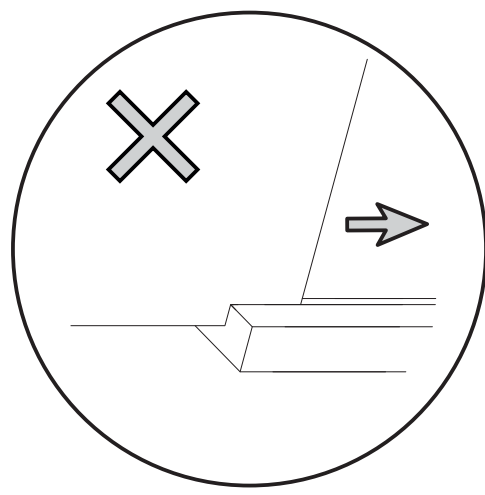
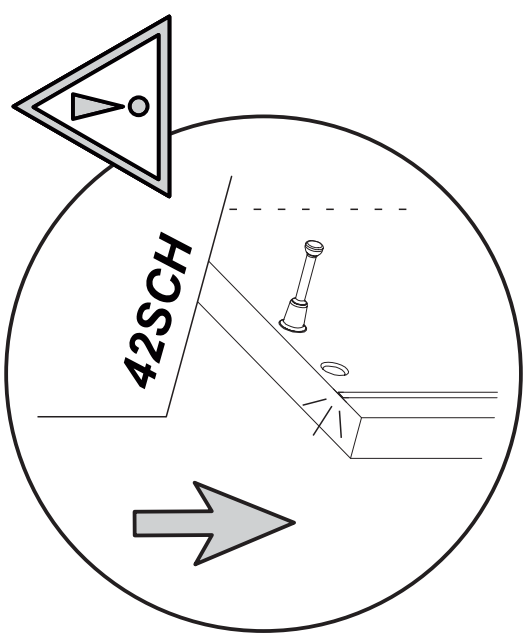
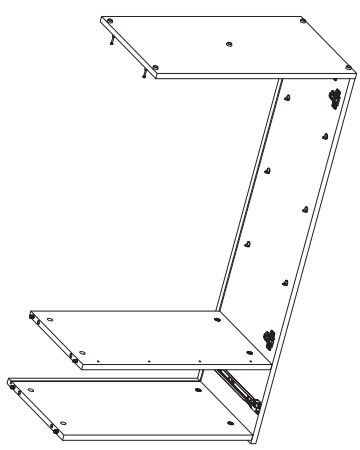
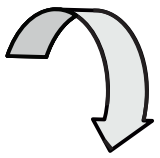

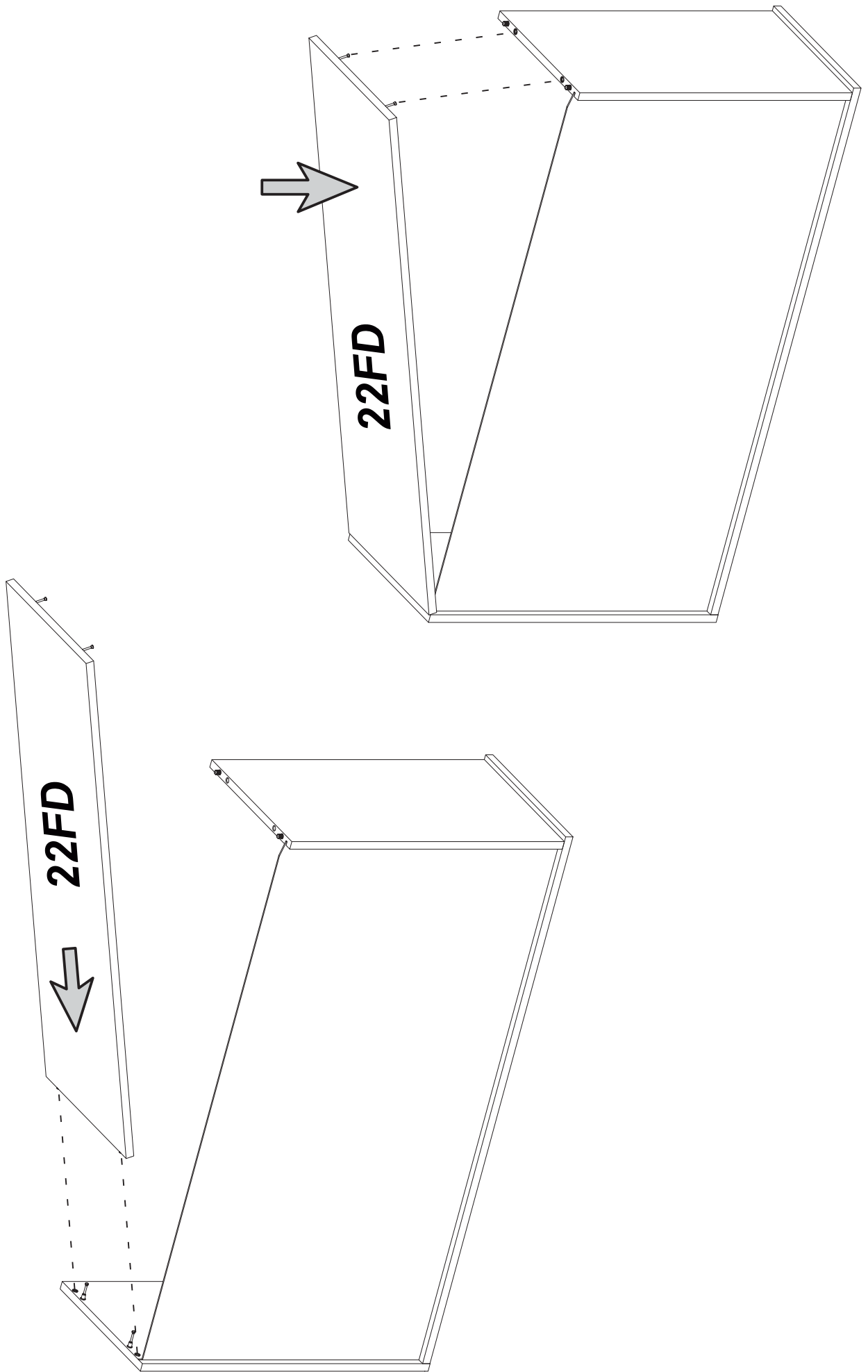

13

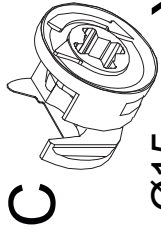

Ø15 x6

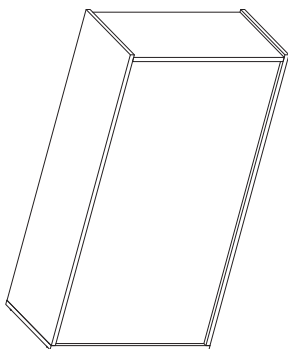
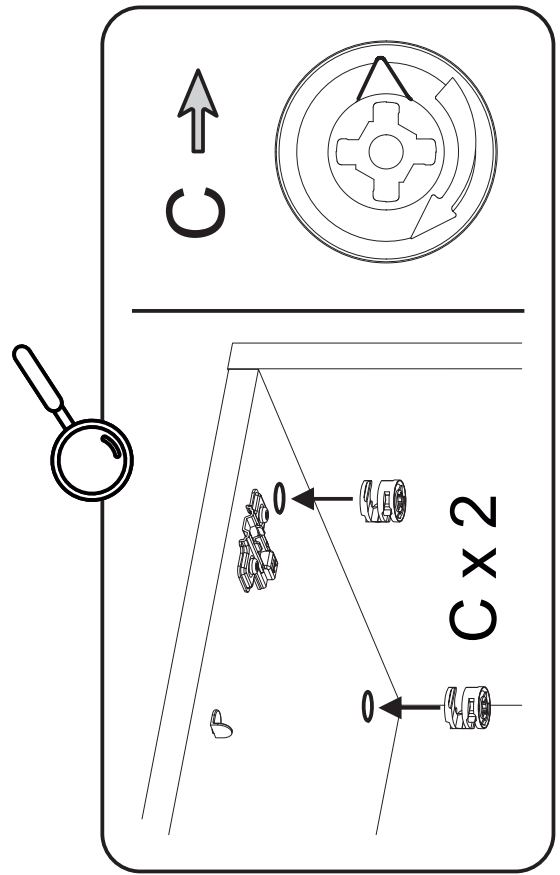
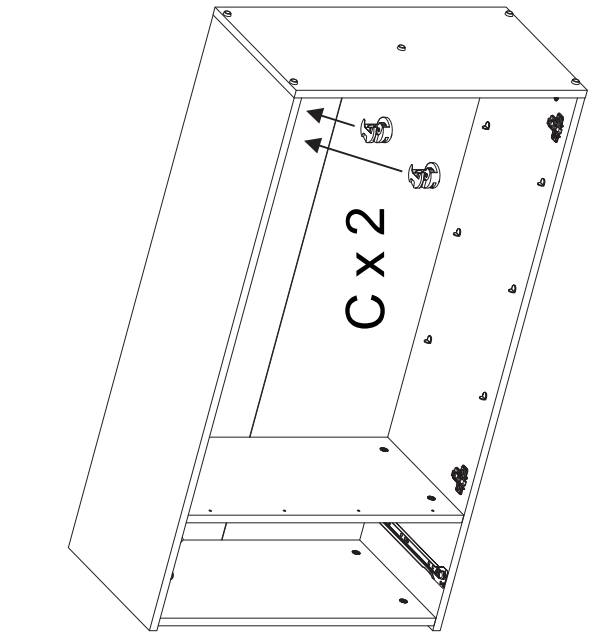
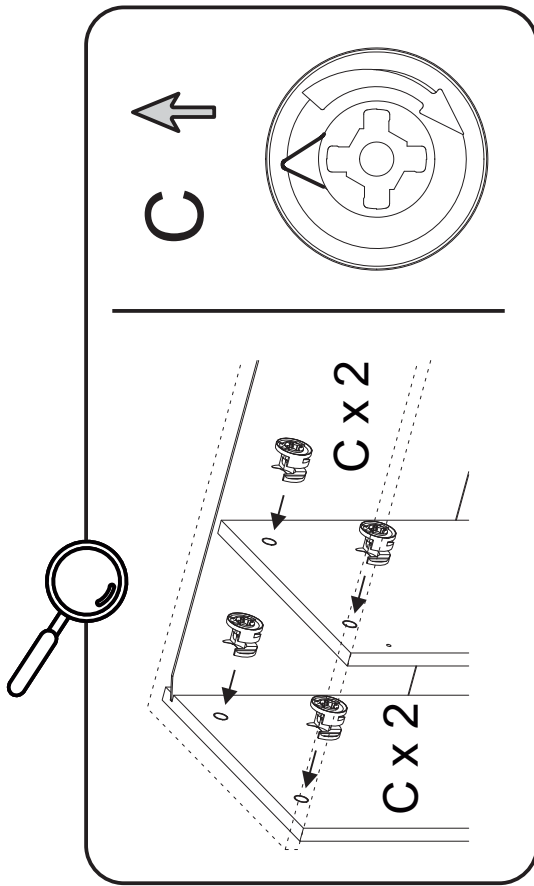
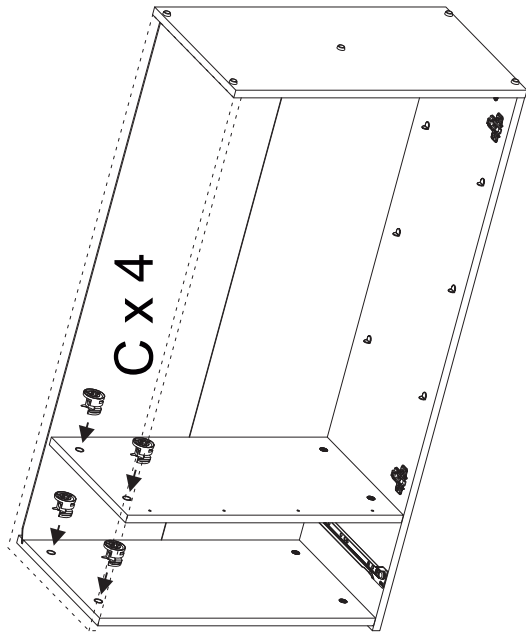

180°

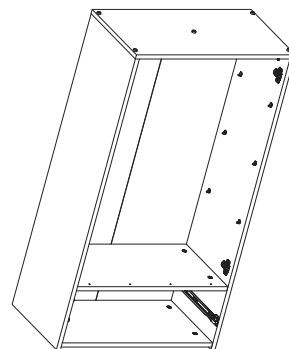

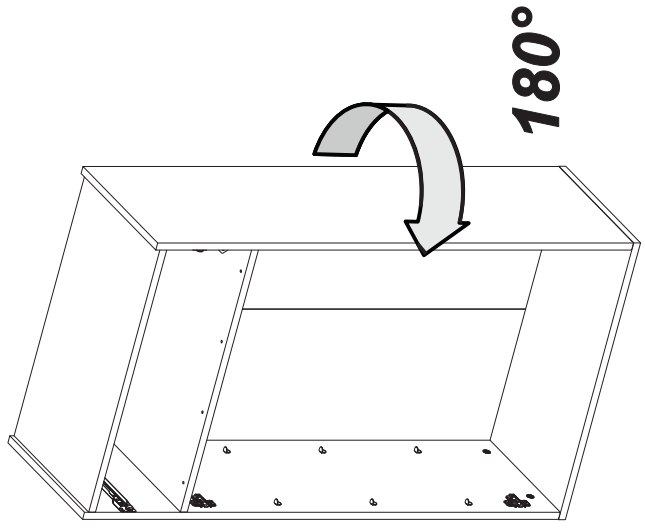
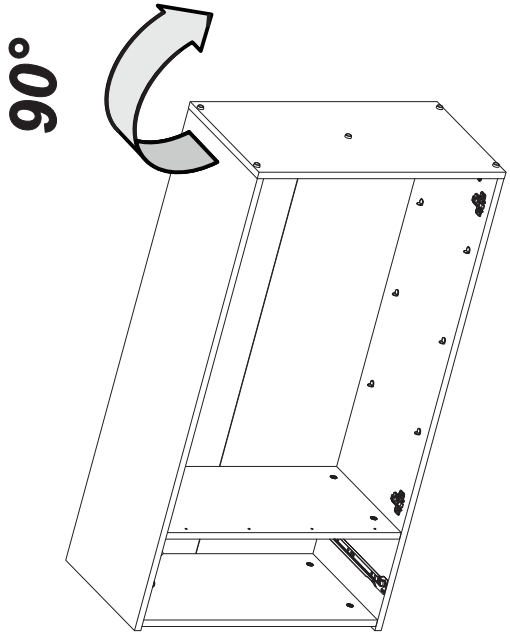
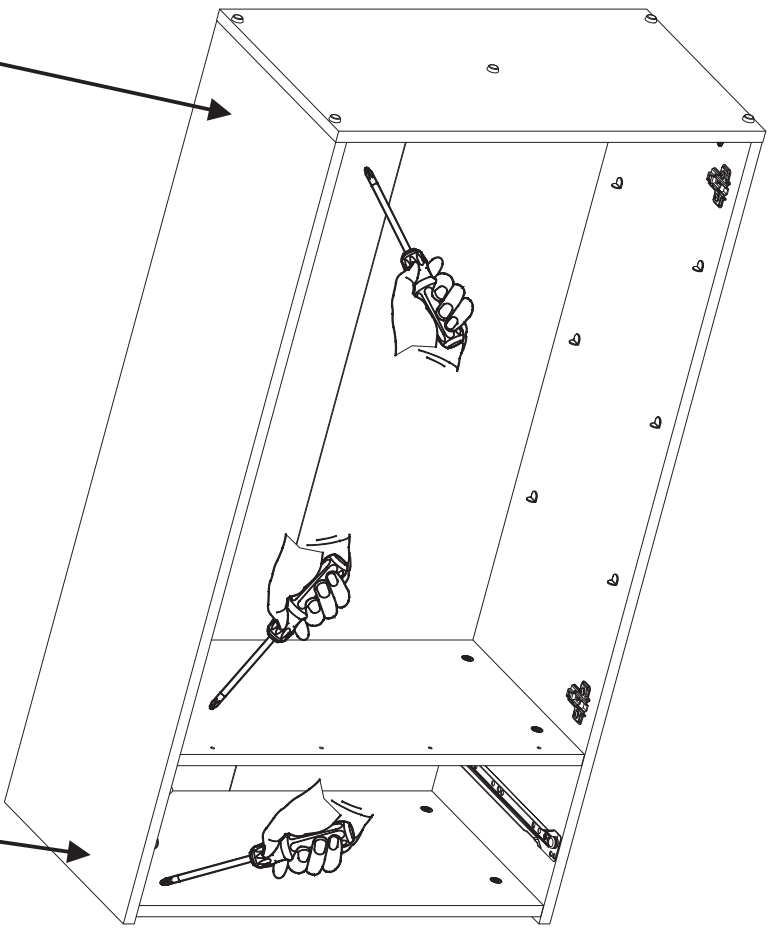
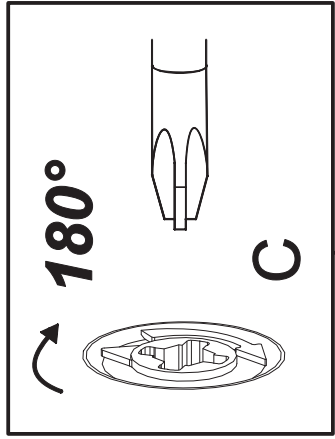
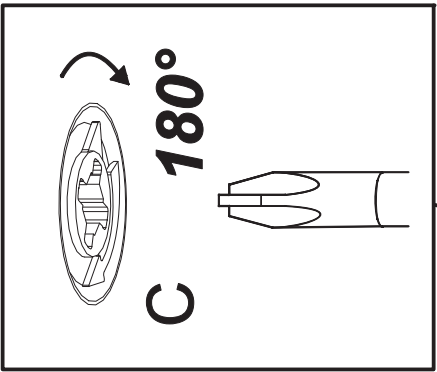

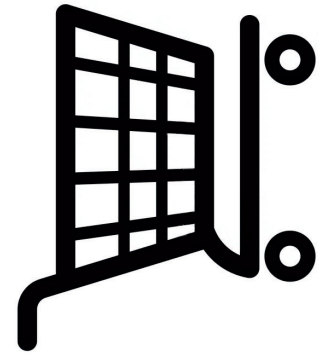
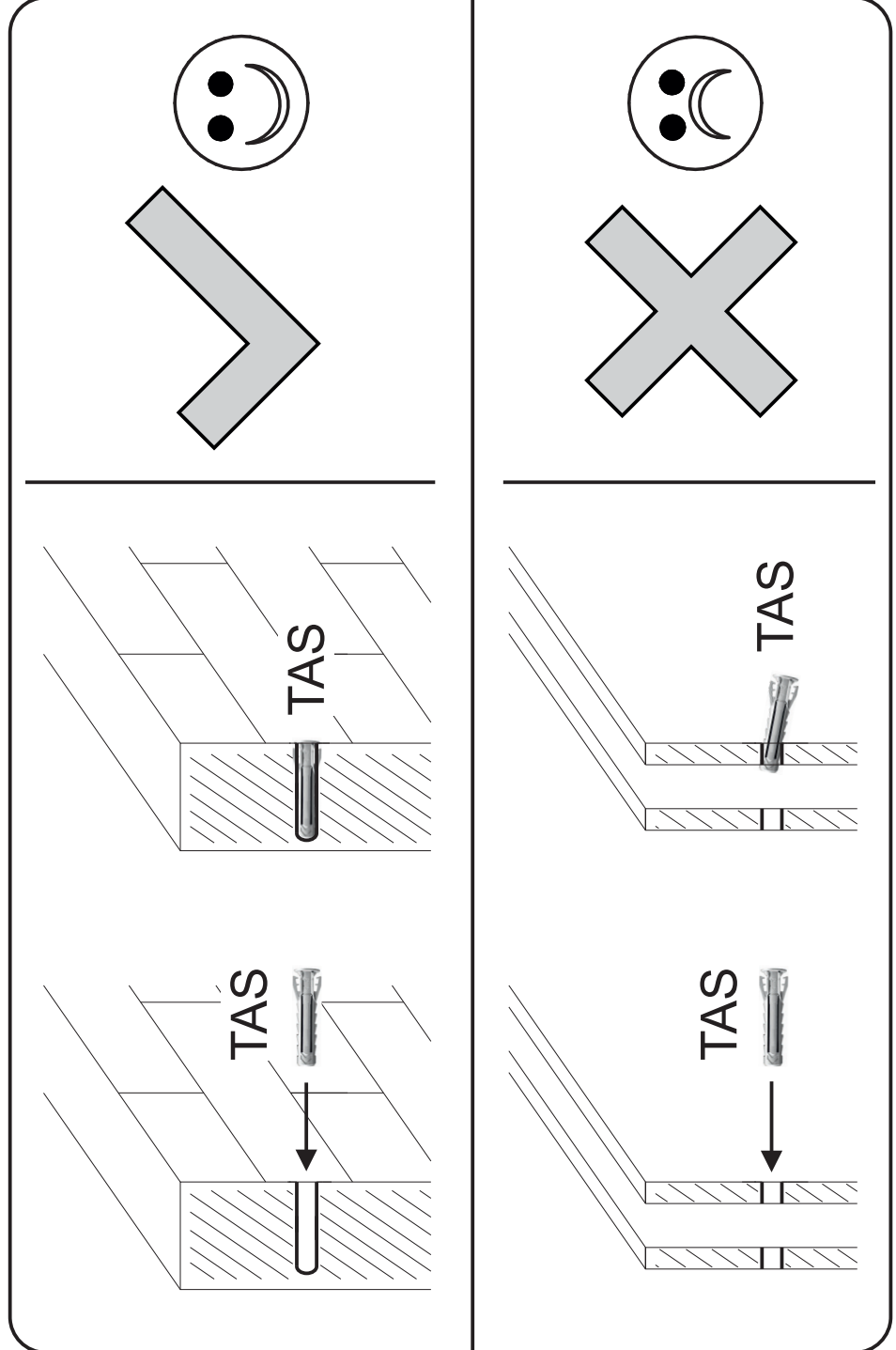
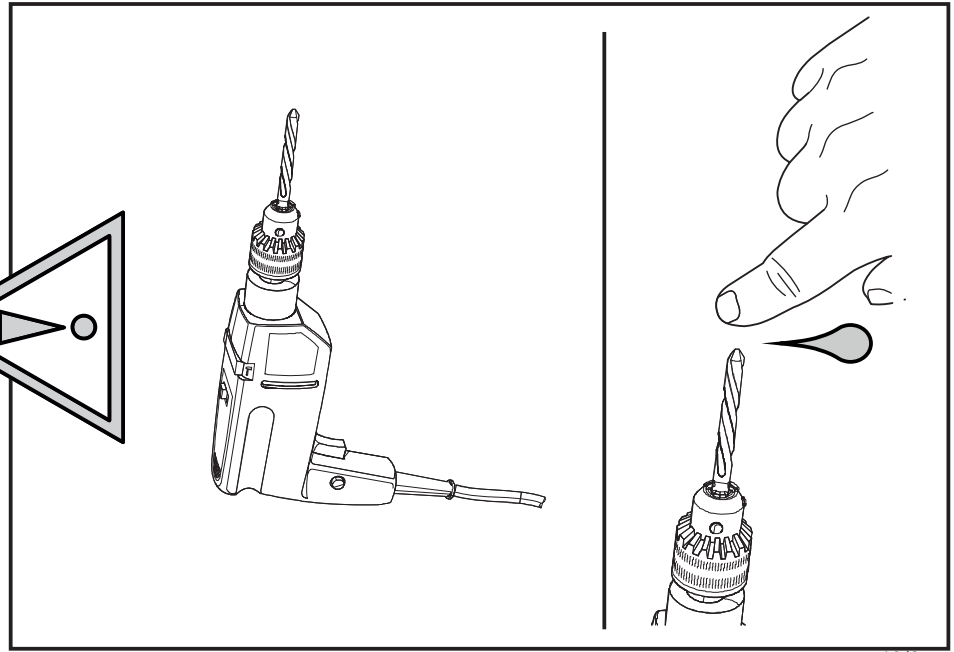
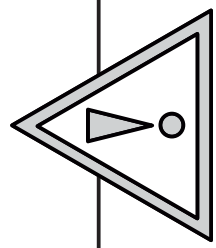
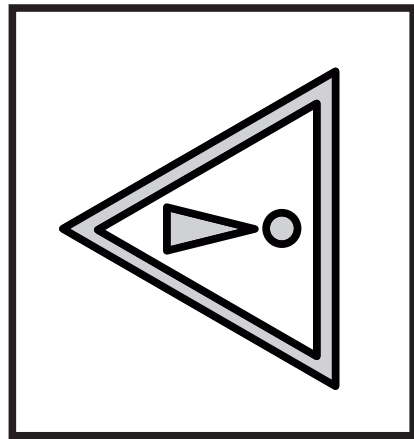



PST x1

3°

PST

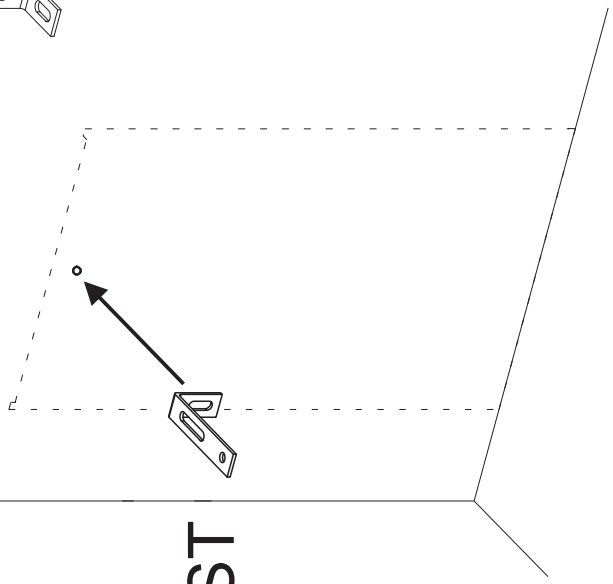

TAS x1

2°

TAS

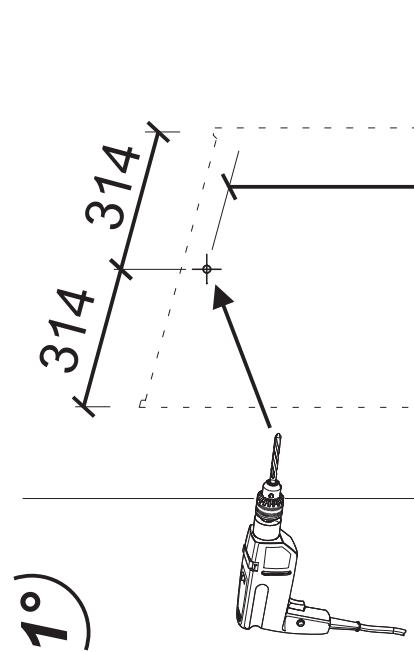
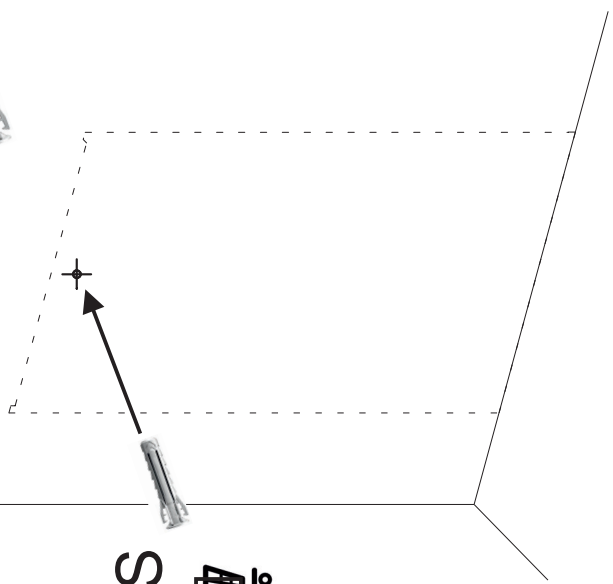

1°

1090
mm

314 314



TAS x1

4°

TAS

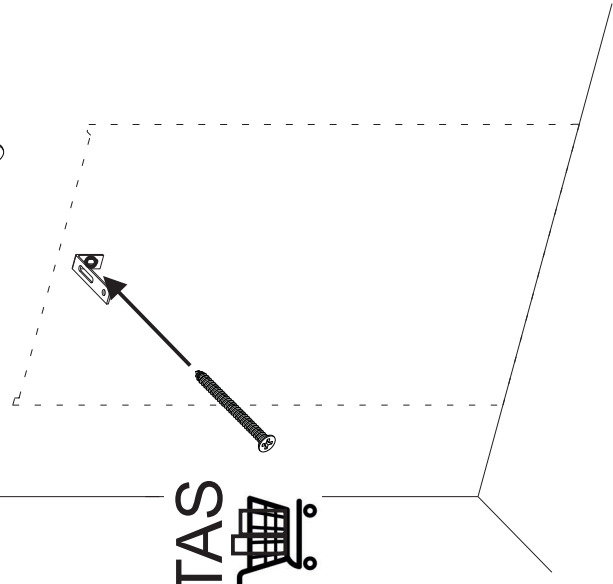

V418 x2



Ø4x18

5°

PST

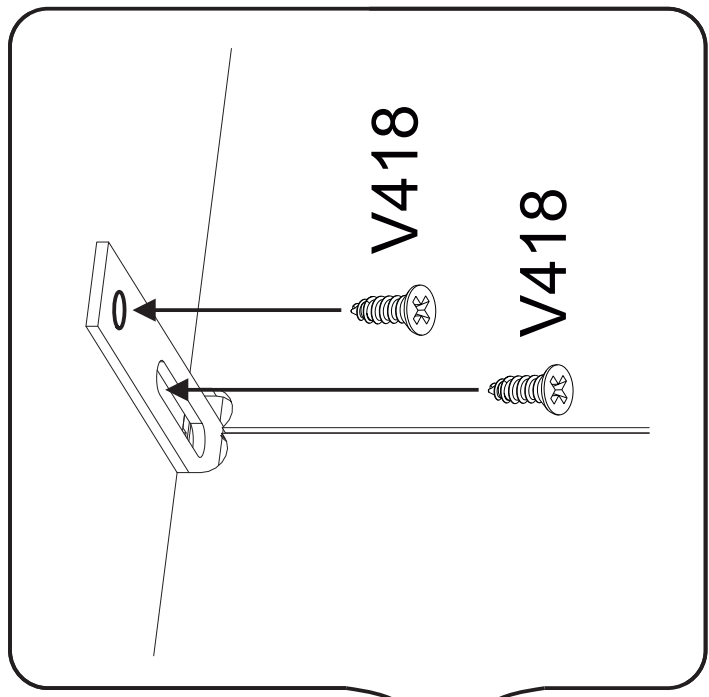
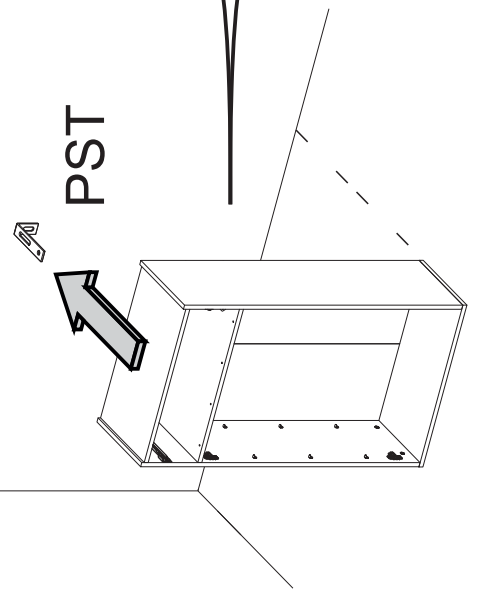

V418

V418

16

COS x4
V415 x8
G x8
G x4

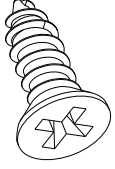

ø4x15 mm

x4

COS

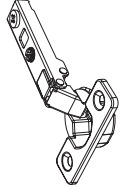

22SP x 2

G

COS

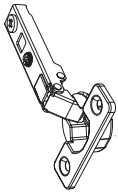

G



G

V415 x 2

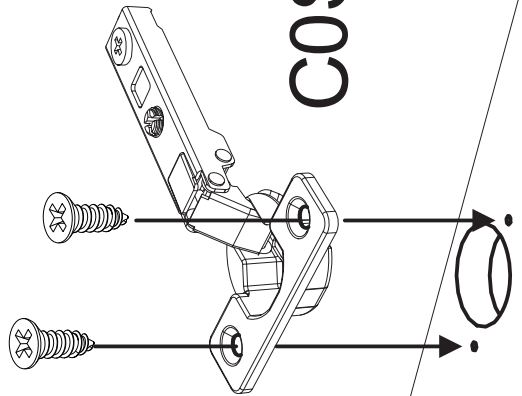

COS

17

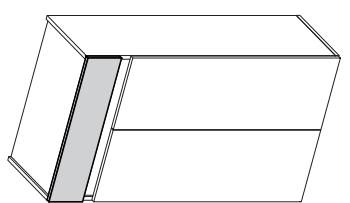
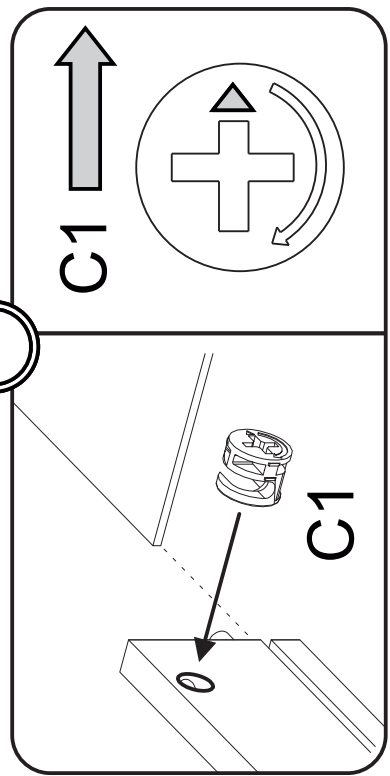
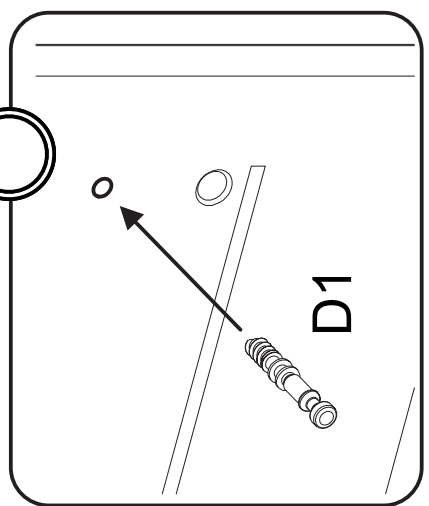
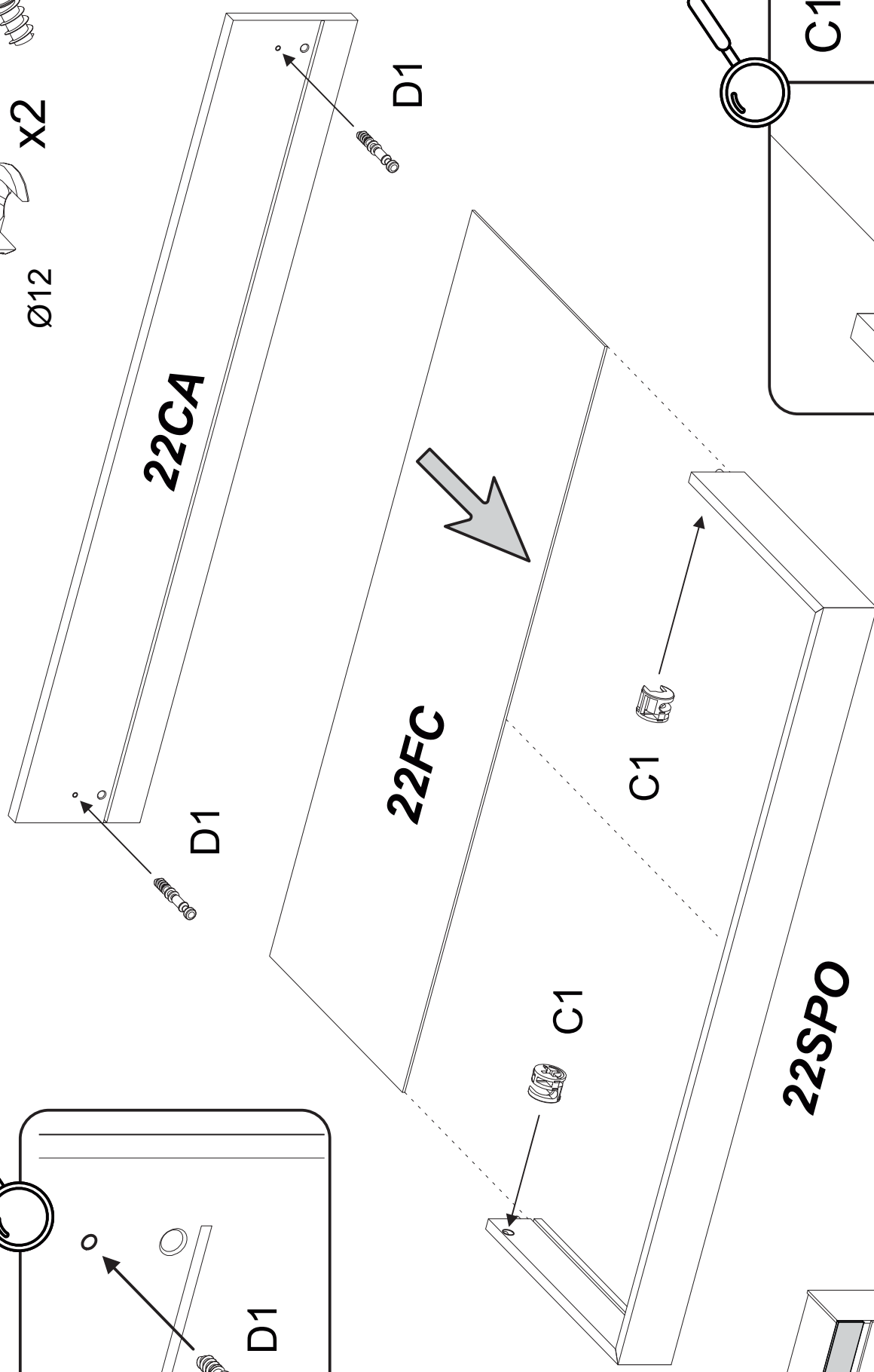
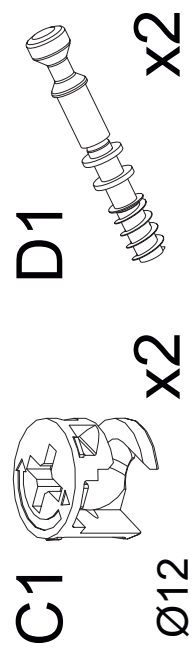

18

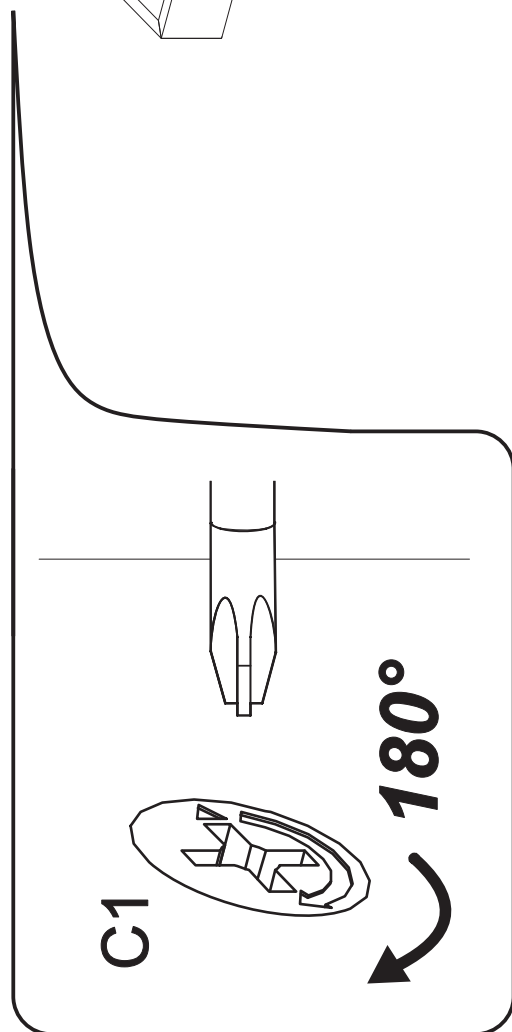
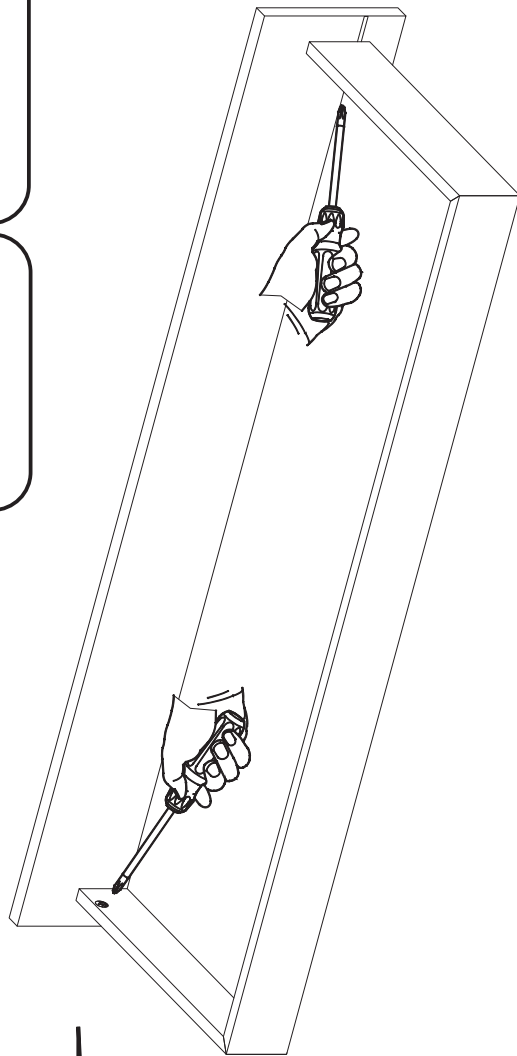
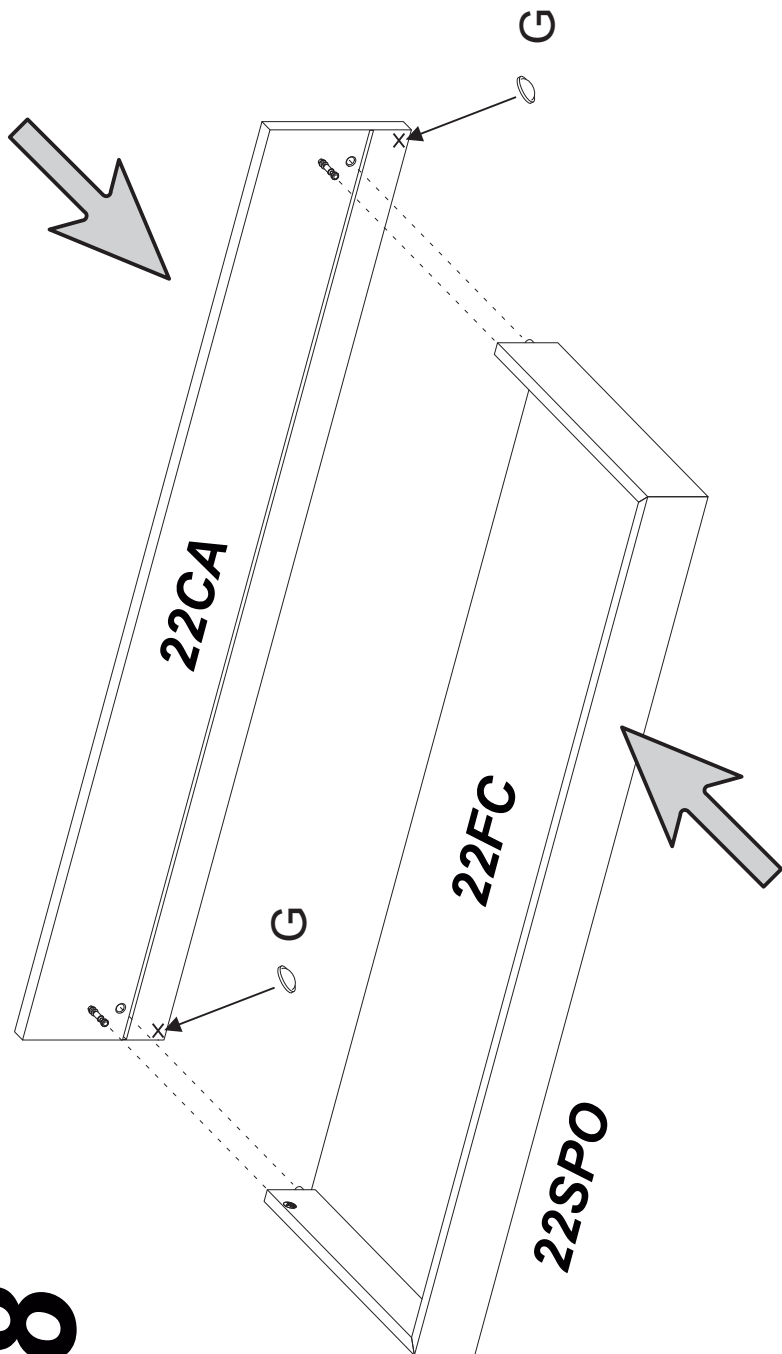
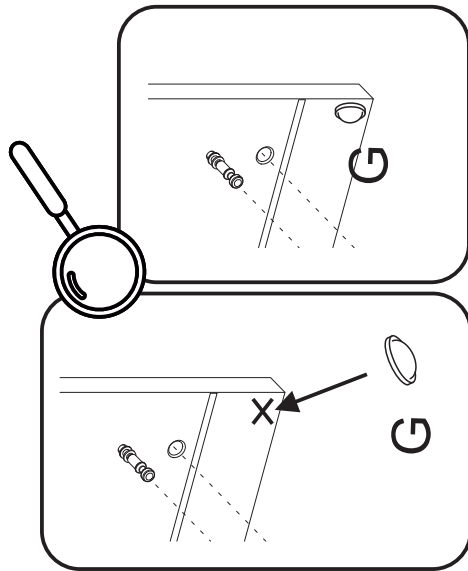
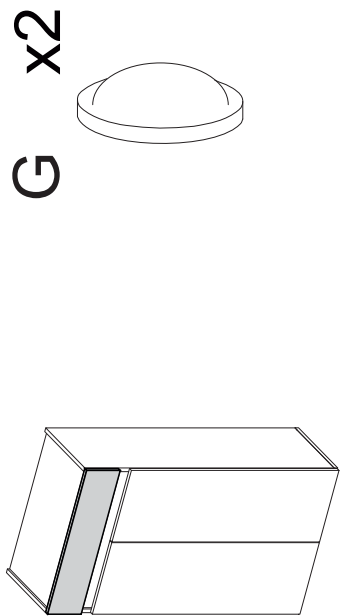

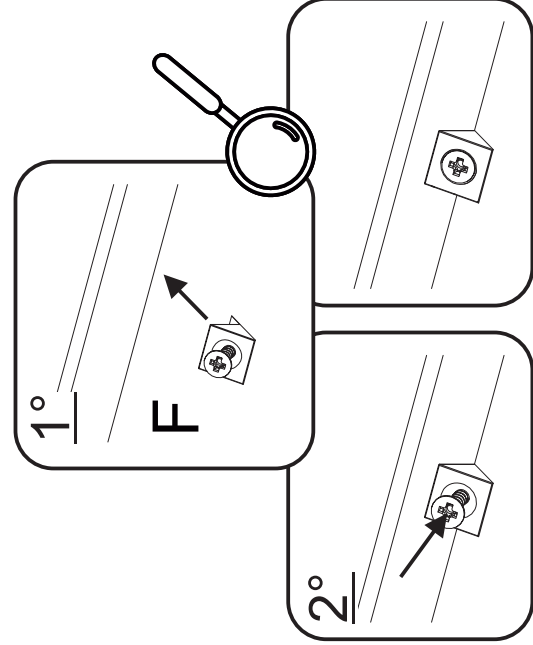
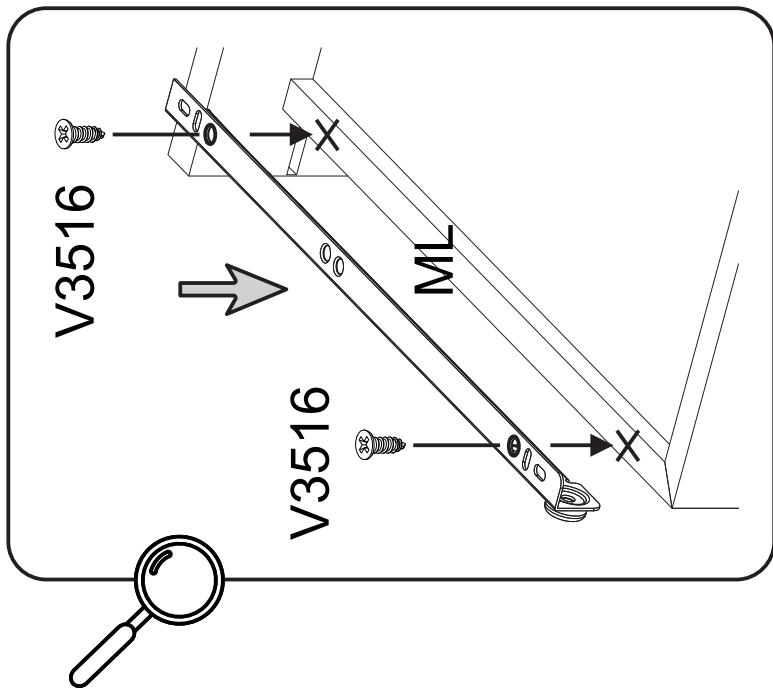
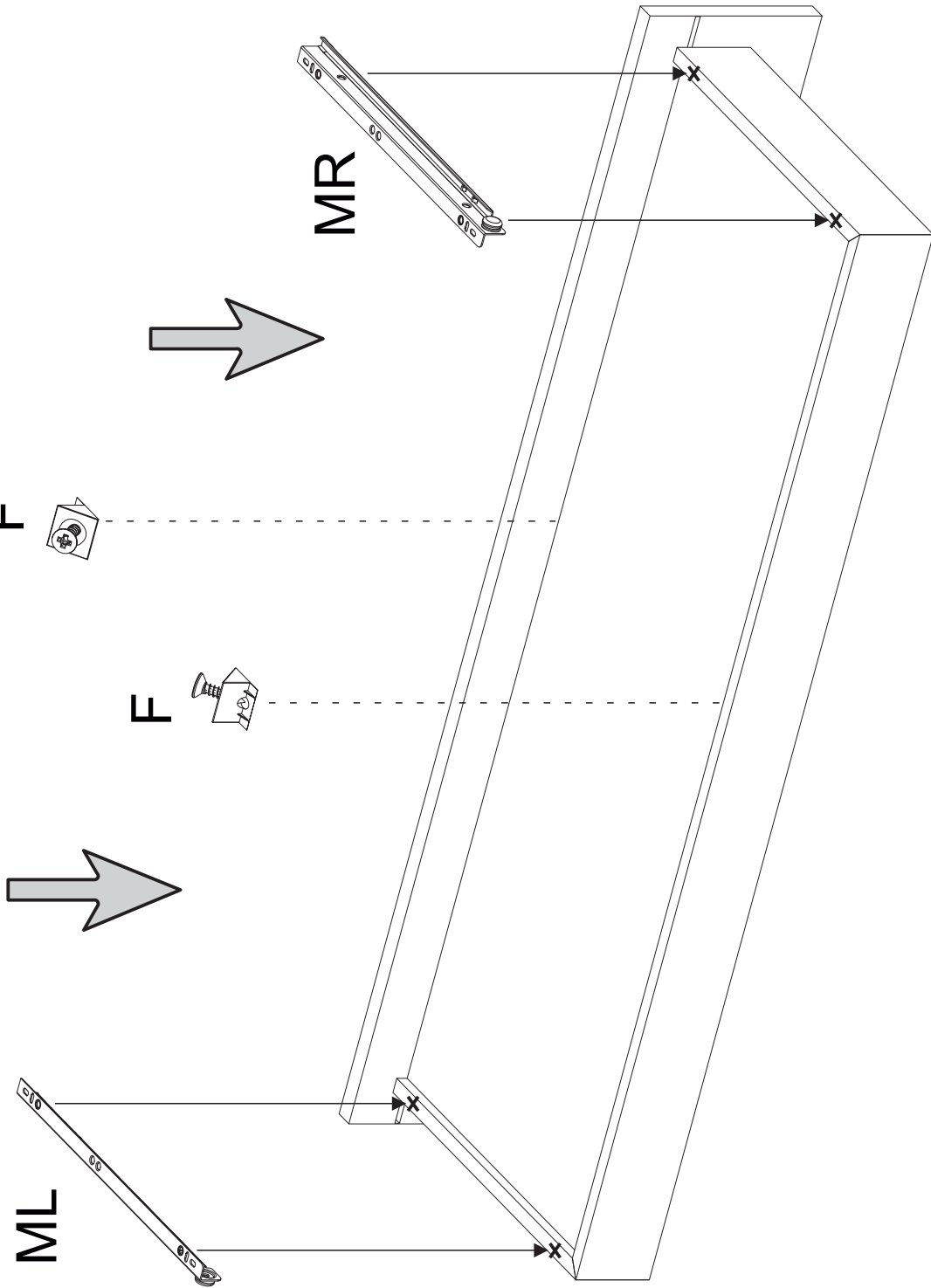
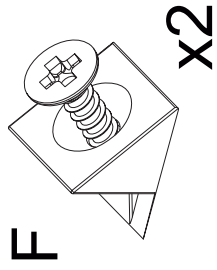
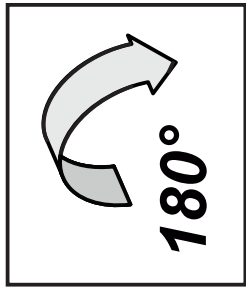

V3540

x4

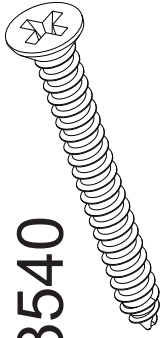

Ø3.5x40 mm.

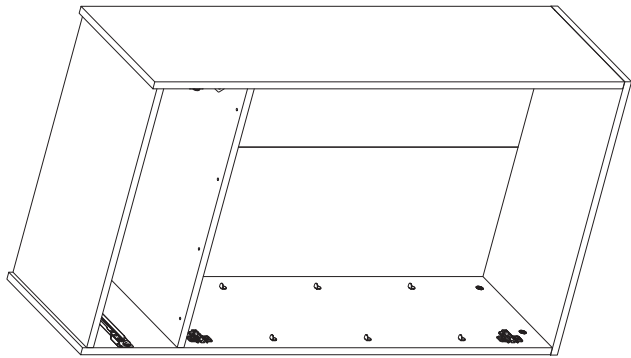

22FAI

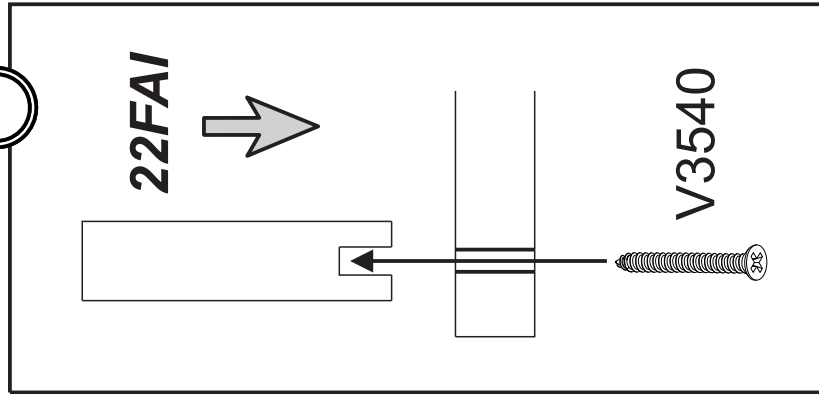
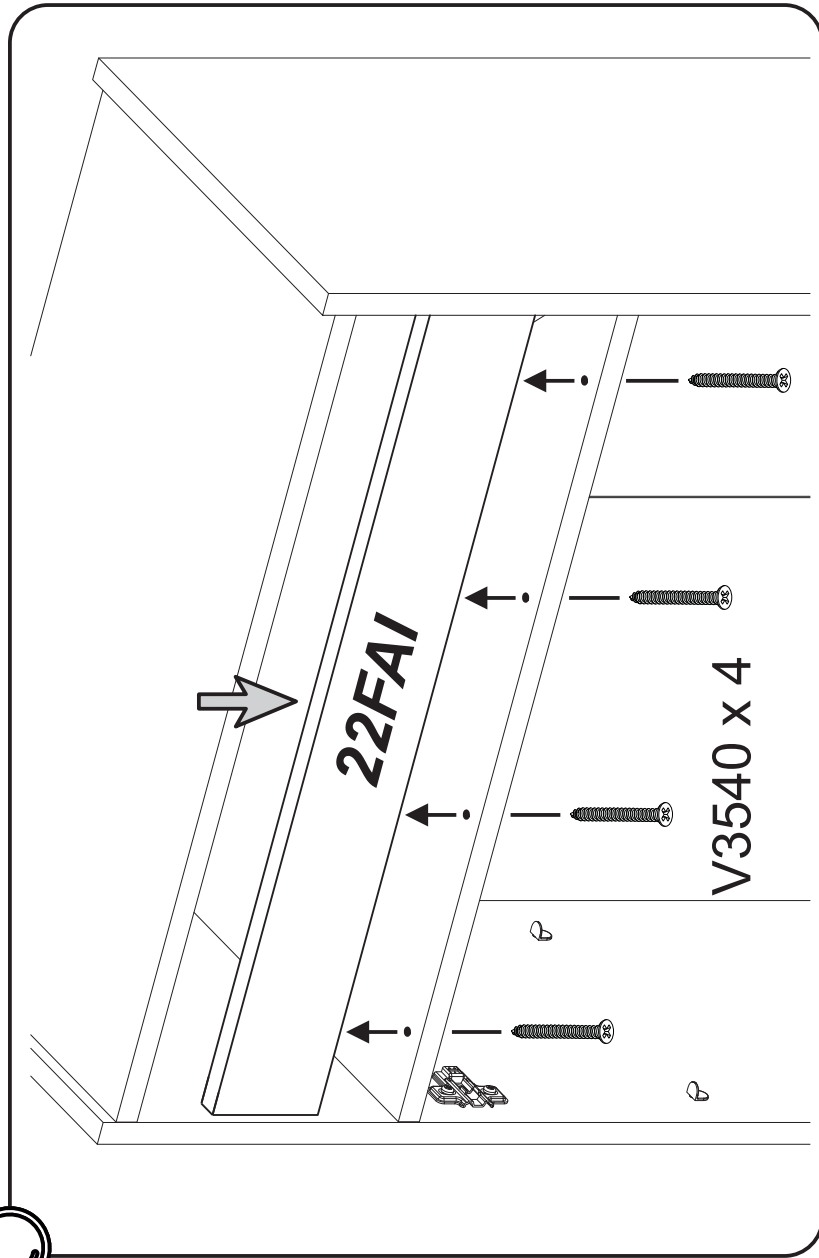

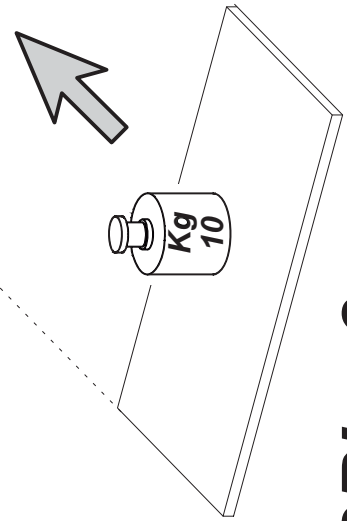
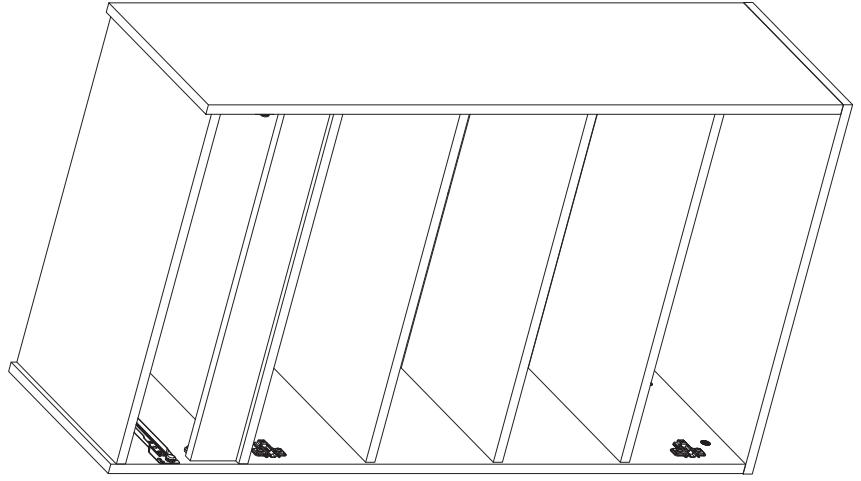
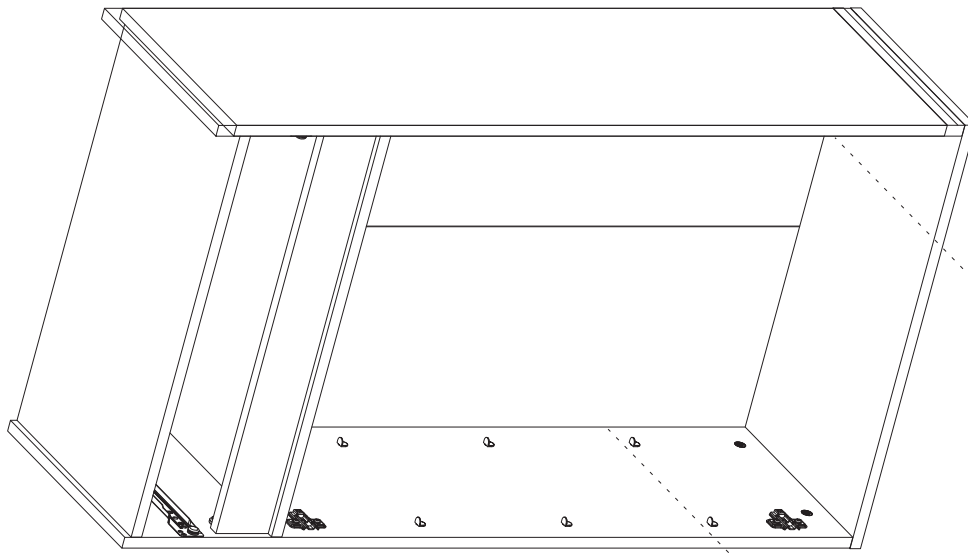

42PI x 3

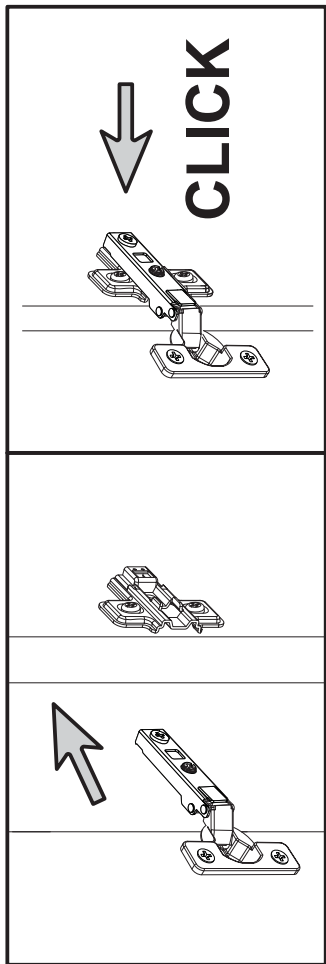

T20

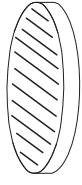

Ø20 mm x8

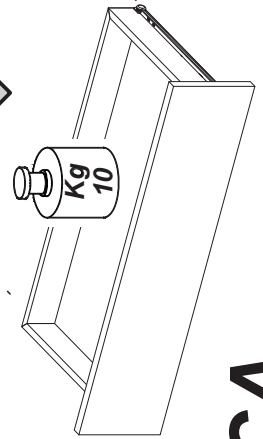
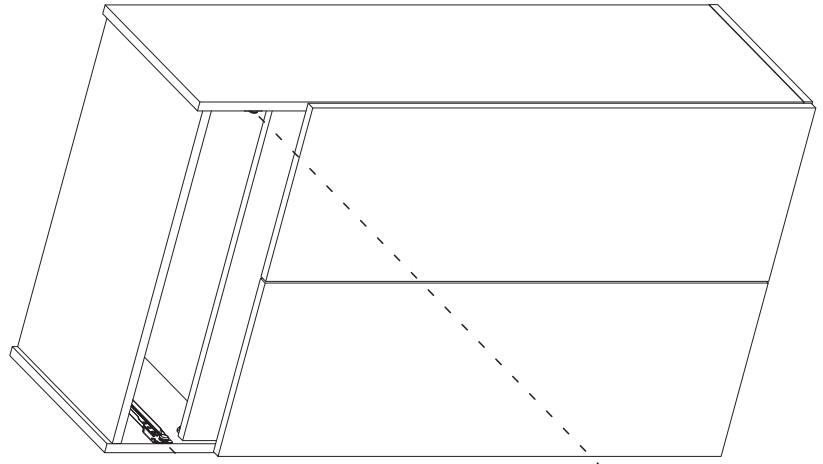

22CA

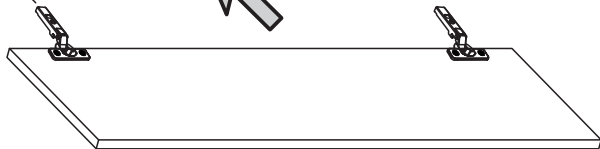
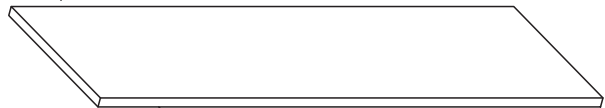
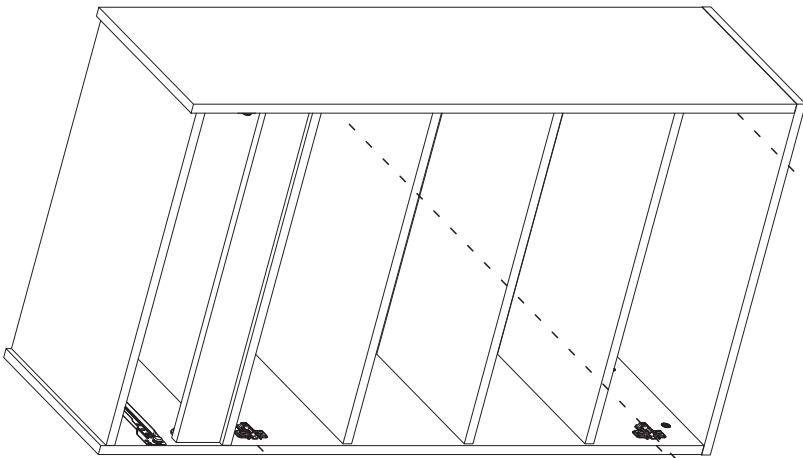

22SP x 2

