

# A306

MONTAGEANLEITUNG / ASSEMBLY INSTRUCTION

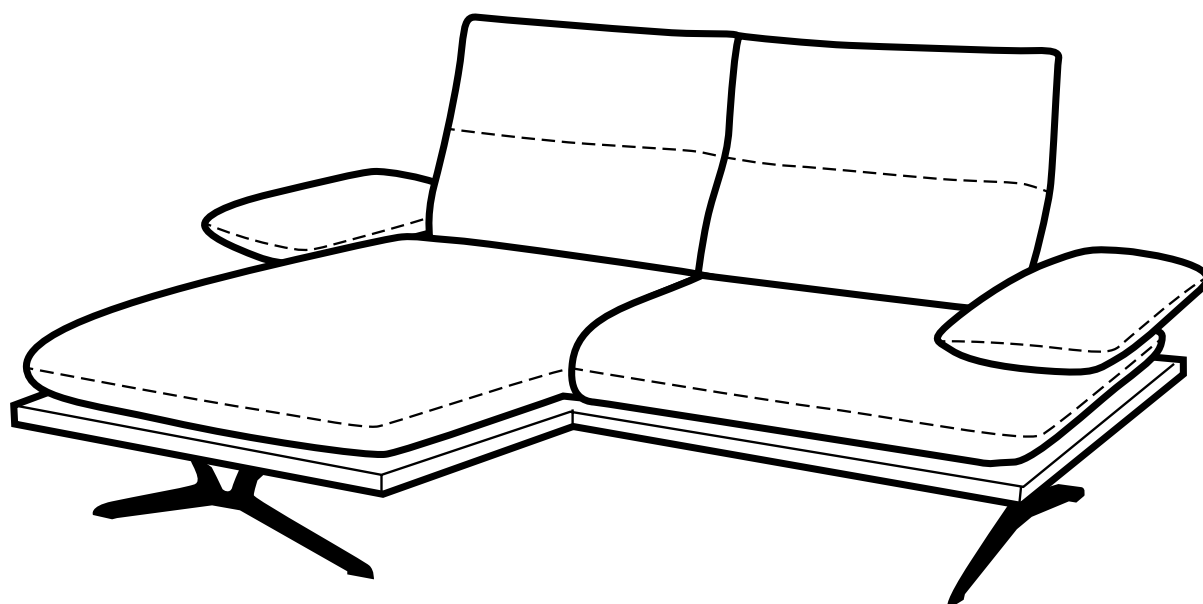

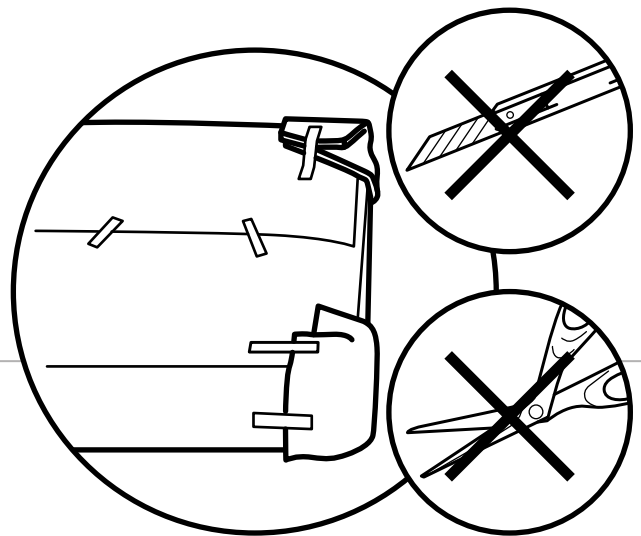
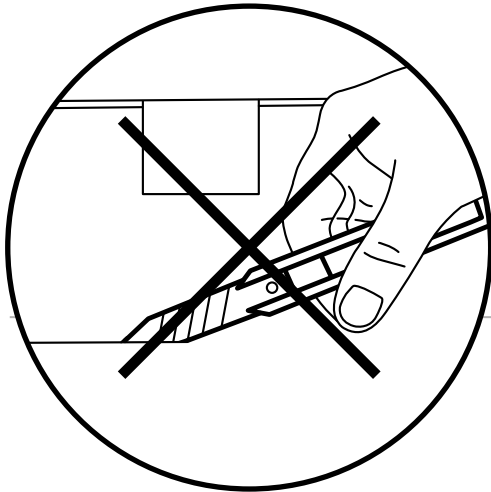
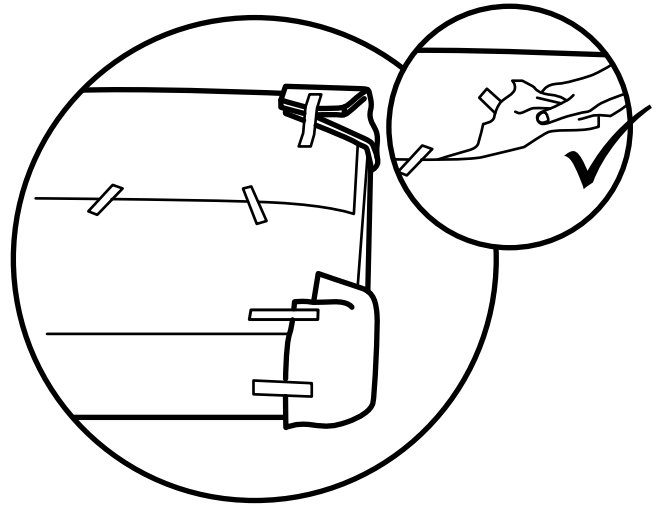
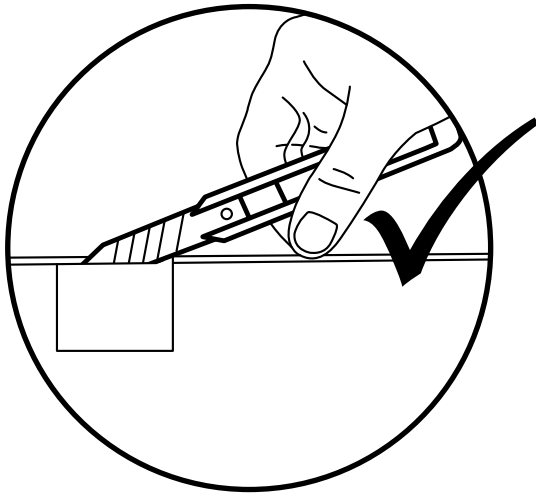

**! Hinweis / Note:**

Für den Aufbau werden zwei Monteure benötigt. Somit vermeiden Sie vorsorglich Beschädigungen.

*Two persons are needed for the assembly. This prevents damage in advance.*

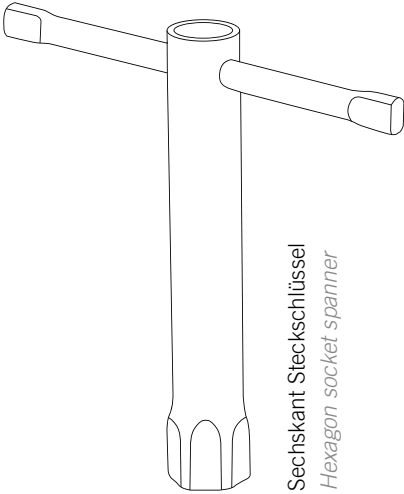
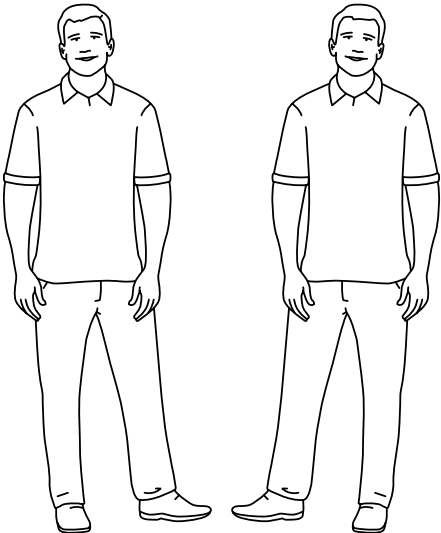

Sechskant Steckschlüssel  
Hexagon socket spanner

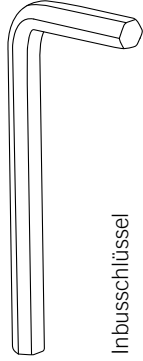

Inbusschlüssel  
Allen key

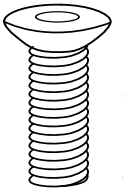

Senkkopfschraube 8x20 mm

**1** Vorbereiten / Preparation

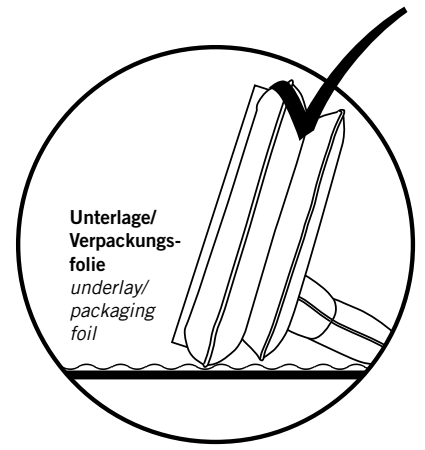
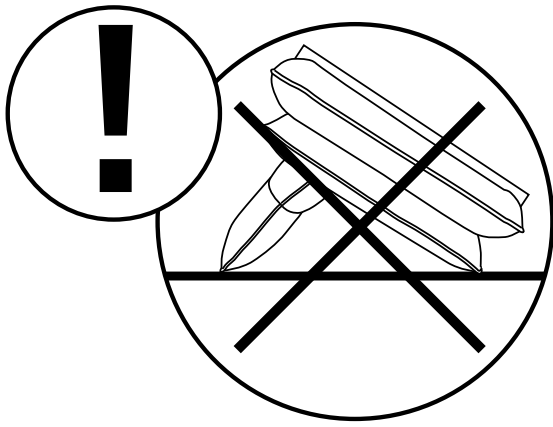

**2**

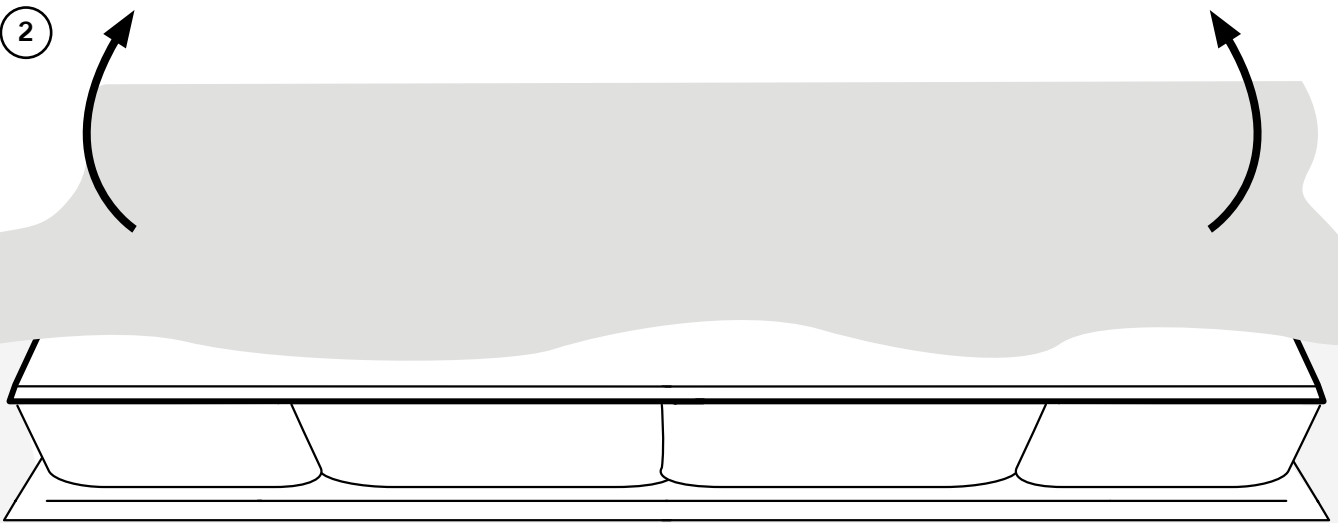

Unterlage / Verpackungsfolie  
underlay / packaging foil

**3**

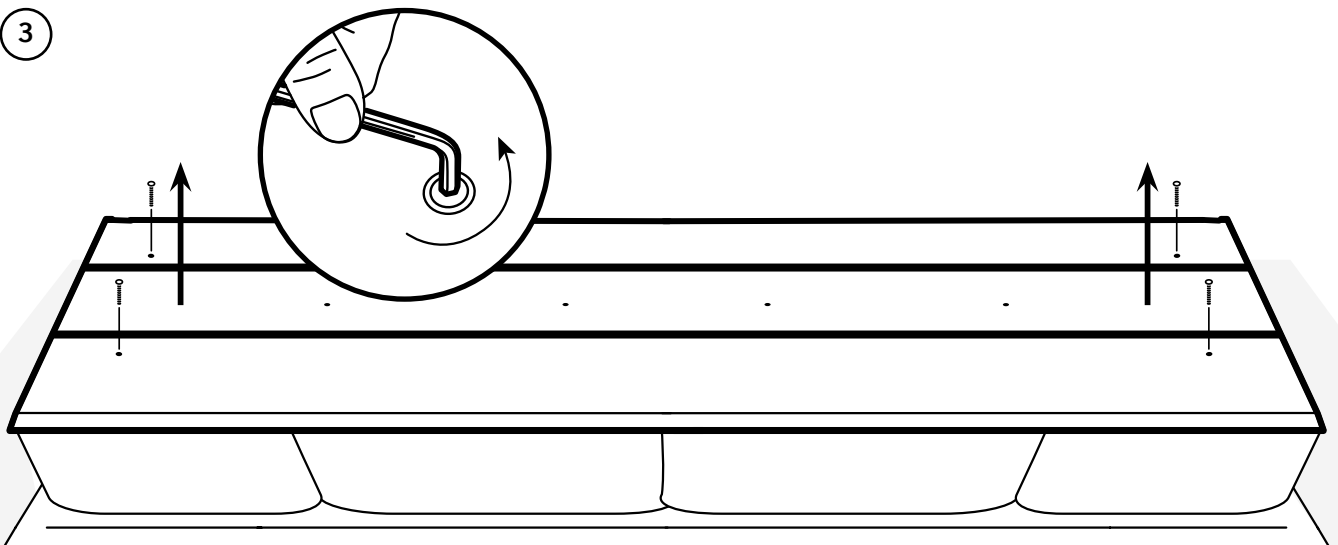

Unterlage / Verpackungsfolie  
underlay / packaging foil

#### 4 Montage Kufe / Assembly runner

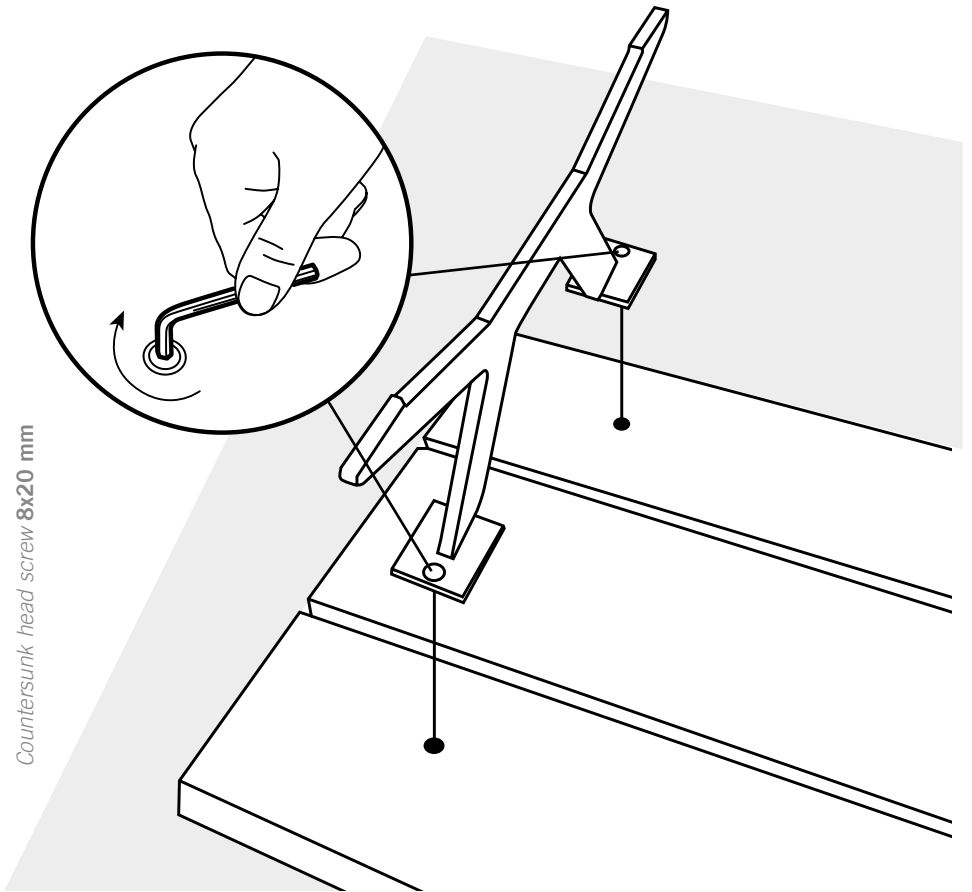
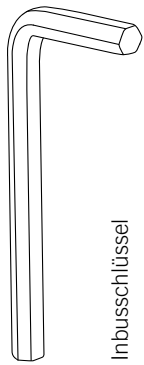

#### 5 Montage Stützfuß (Ausführungsabhängig bei Modellen mit Liege) Assembly support foot (specific for models with lounger)

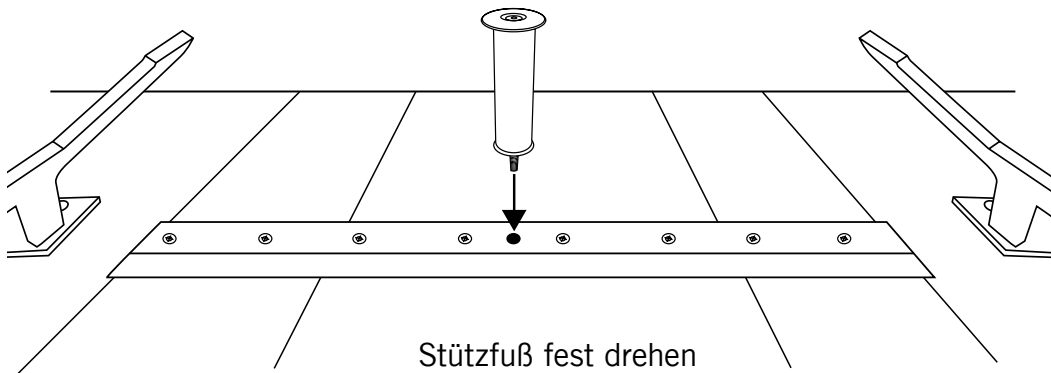

Stützfuß fest drehen  
Tighten the leg support

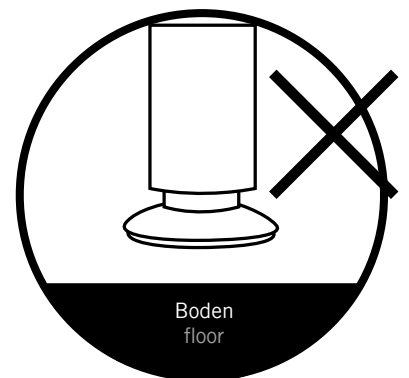
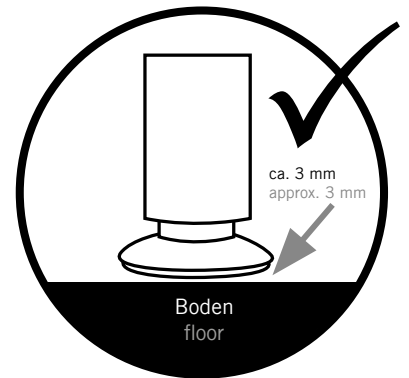

Nach dem Aufstellen für die optimale Stabilität den Fuß unten am Drehteller bis kurz über den Boden heraus drehen (Abstand ca. 3 mm). Das Möbel darf nicht durchhängen.

After positioning, turn the rotary table just above the ground (distance approx. 3 mm). Avoid sagging.

**6** **Verbindung** (Ausführungsabhängig bei Modellen mit Liege)  
**Connecting** (specific for models with lounger)

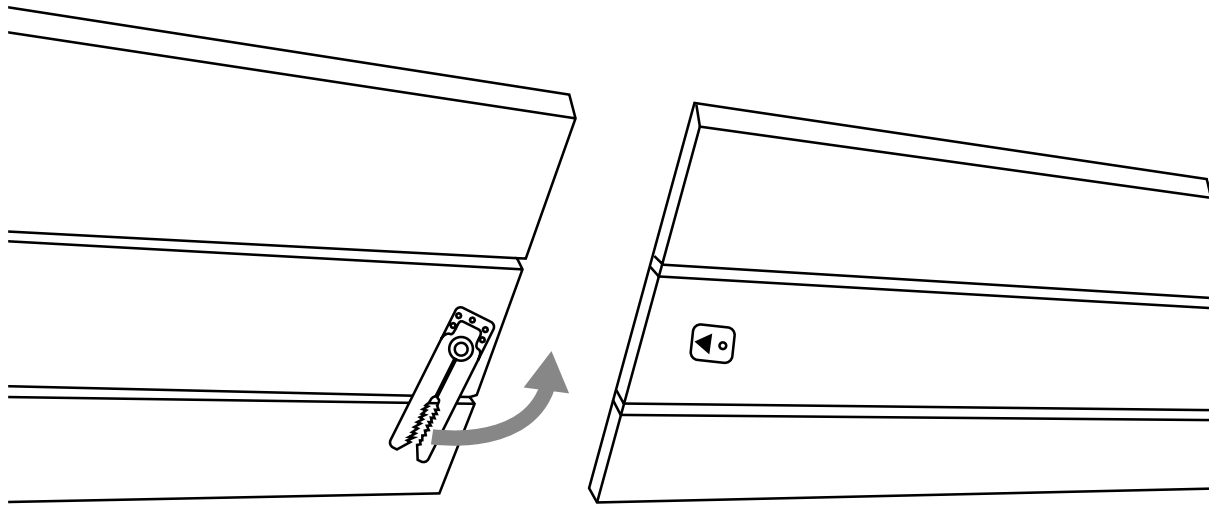

Die Verbinder sind vormontiert.  
The connectors are pre-assembled.

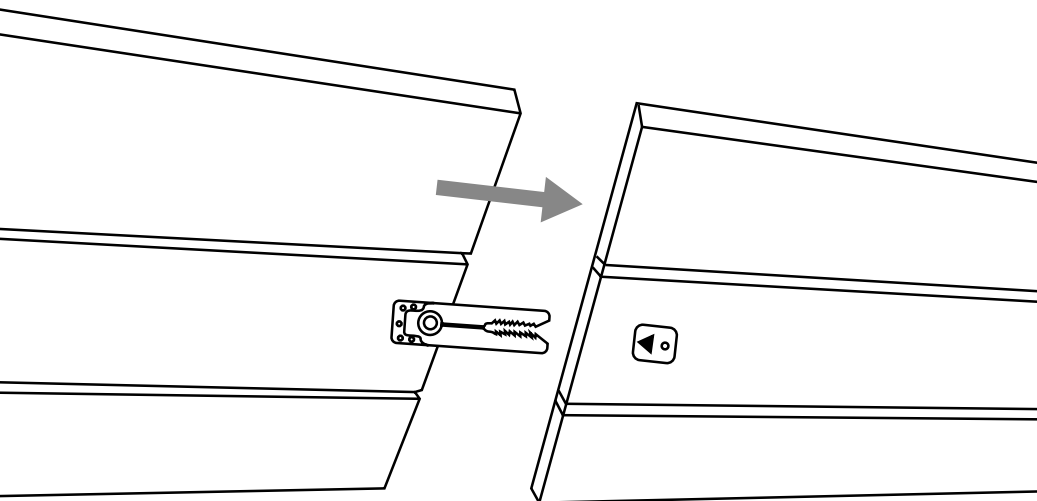

Fest zusammenschieben.  
Push together.

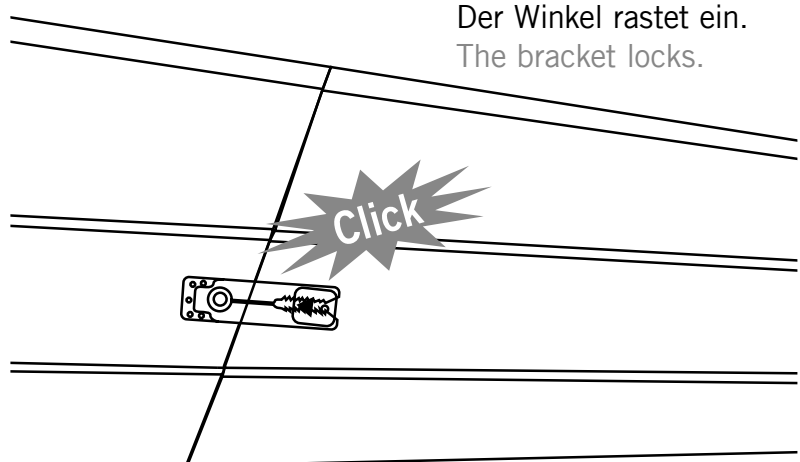

Der Winkel rastet ein.  
The bracket locks.

**!** **Hinweis / Note:**

Lösen der Elemente:  
Mindestens 5 cm anheben  
und die Elemente ausein-  
ander ziehen.

Loosening the elements:  
Lift at least 5 cm and pull  
the elements apart.

**!** Hinweis / Note:

Drehen Sie zur Montage den Sitz schräg über das Plateau und schrauben Sie zuerst die, für die Montage angebrachten, Muttern von den Gewindestäben ab.

To assemble, turn the seat at an angle over the plateau and first unscrew the nuts attached for assembly from the threaded rods.

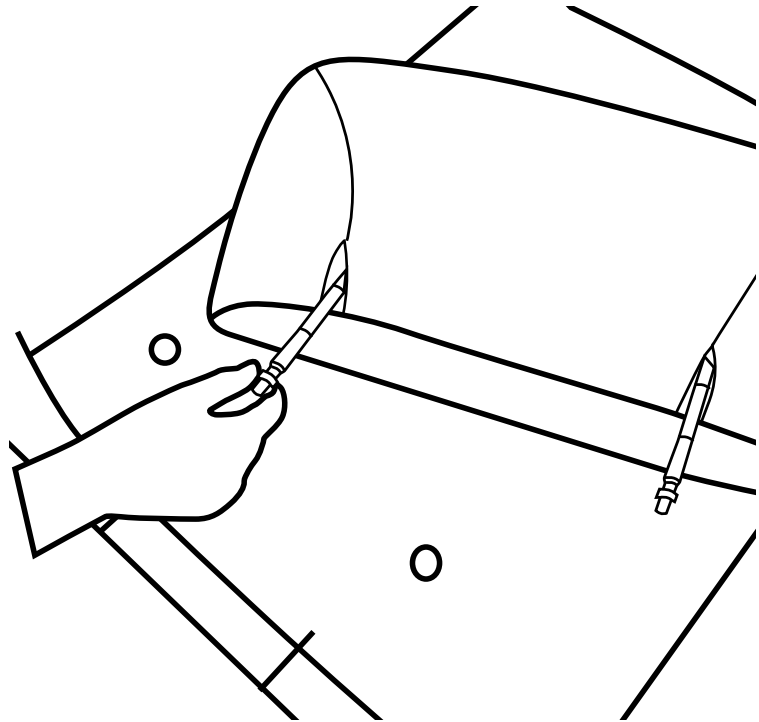

**Richtige Seite beachten!  
Die Schräge der Armlehne  
ist hinten!**

**Note the correct side!  
The slant of the armrest  
is at the back!**

8

**!** Hinweis / Note:

Achten Sie darauf, dass die Gewinde die, im Sofa angebrachten, Hülsen durchlaufen.

Make sure that the threads pass the sleeves fitted in the sofa.

