

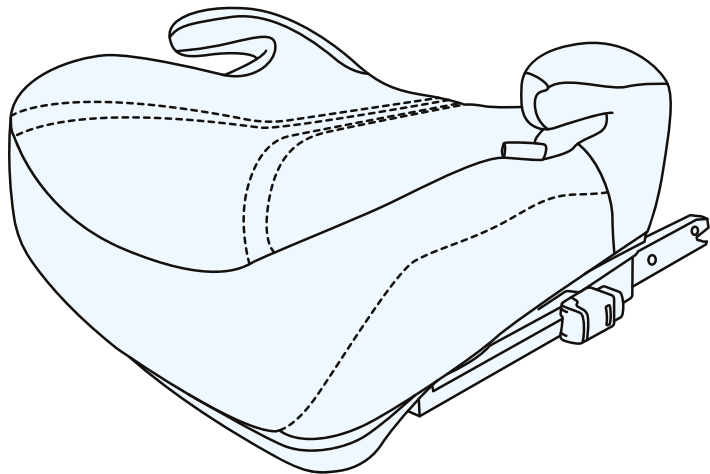

# I-BOOST 2 PRO i-Size USER GUIDE



MODEL: I-BOOST 2 PRO i-Size ECE R129.03

**NOTE!** Product graphics serve an illustrative function!

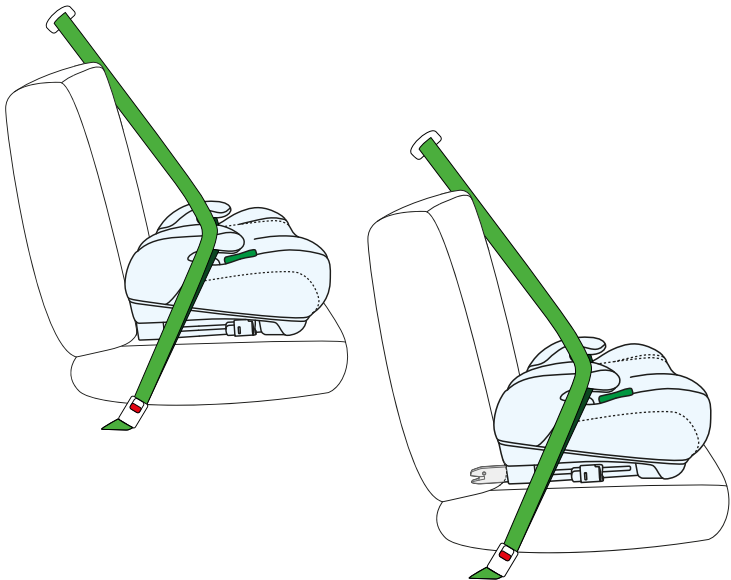

## **1.0 Usage**

The car seat has been designed, tested and approved for use in accordance with the requirements of UN/ECE Regulation No. 129 concerning the approval of child restraint systems (UN/ECE R129/03).

The I-BOOST 2 PRO i -Size car seat is intended for for transporting children with a height between 125-150 cm (up to approximately 12 years). The child should be fastened using three-point car seat belts for adults.

The car seat can be installed in the car in the places indicated by the manufacturer in the vehicle manual. It is required to read the vehicle manufacturer's operating instructions.

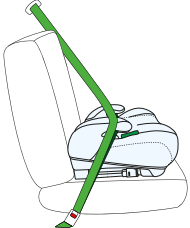
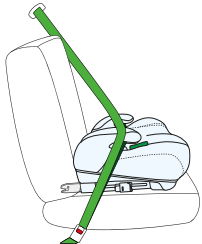
Hight of the child	Car seat setting	Car seat mounting
125-150cm		ISOFIX + three-point car seat belt
		Three-point car seat belt

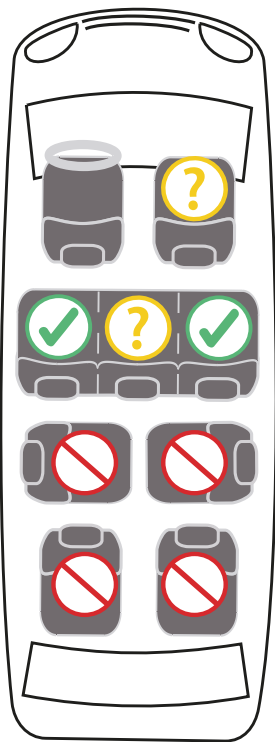

## 2.0 Safety instructions

Please take a few minutes to read this instruction manual in order to ensure the proper safety of your child.



- The car seat **MUST NOT** be installed on the vehicle seats mounted backwards or sideways.



- The car seat can only be installed on the vehicle seat with a three-point car seat belt.
- The front air-bag must be deactivated.



- It is recommended to install the car seat on the vehicle back seats only.



## !WARNINGS!

Please take a few minutes to read this instruction manual in order to ensure the proper security of your child. Many injuries that are easy to avoid are caused by reckless and improper use of the car seat.

! The car seat is designed to be installed only on forward facing vehicle seats. The car seat must not be installed on rearward facing or side facing vehicle seats.

! If the car seat is installed in the front vehicle seat, the front air-bag must be deactivated. It is recommended to install the car seat only on the vehicle back seats. Please refer to your vehicle operating manual for information on the suitability of the vehicle seat for use with a car seat.

! Remember - the internal safety harness holding the child should be adjusted to the child's body shape and not twisted. For this reason, the child should not wear thick clothes under the safety harness.

! It is recommended to keep the instruction manual of the car seat throughout its lifetime.

! In the event of an emergency, you have to quickly unfasten the car seat belt. This means that the release button of the safety harness is not fully secured; make sure your child does not play with the safety harness.

! The car seat should be replaced when it has been subjected to violent stresses during a traffic accident.

! The car seat cannot be modified in any way without the acceptance of the relevant authority granting approvals. Failure to install the car seat in accordance with the manufacturer's instructions may pose a threat to people's life and health.

! Protect the car seat from direct sunlight, otherwise your child may be burnt by its heated parts. Protect your child and the car seat from sunlight.

! Never leave your child unattended in the car seat.

! Make sure that the luggage and other objects are adequately secured, in particular on the rear parcel shelf, as they can cause injuries in the event of a collision.

! The car seat cannot be used without its cover.

! Do not use any attachment points, other than those described in the instruction manual and marked on a car seat.

! All hard elements and plastic parts of the car seat must be placed and installed in a way preventing them from being trapped by the sliding seat or vehicle doors under normal vehicle operating conditions.

! Regularly check the technical condition of the car seat, pay special attention to the fixing points, seams and adjusting parts. It is important to ensure that all mechanical elements are fully operational. Never grease or oil parts of the car seat.

! Do not use the car seat if its parts are damaged or loose.

! On some vehicle seats made of delicate materials, the use of car seats may leave marks and/or discolouration. In order to prevent it, you can place a blanket, towel or similar product under the car seat.

! Do not use any replacement covers, other than those recommended by the manufacturer, as the cover is an integral part of the safety system of a car seat.

! Make sure that the car seat is correctly secured before each journey in the car.

! The car seat must be secured at all times, even when not in use. The car seat that is not fastened can injure the passengers even during emergency braking.

! Set a good example for your child and always fasten your car seat belt. An adult who is not fastened with a car seat belt can also pose a threat to a child.

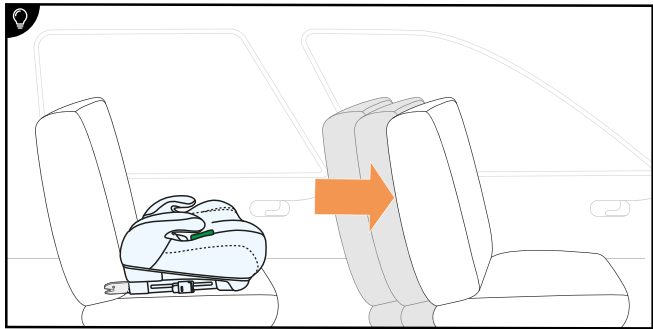
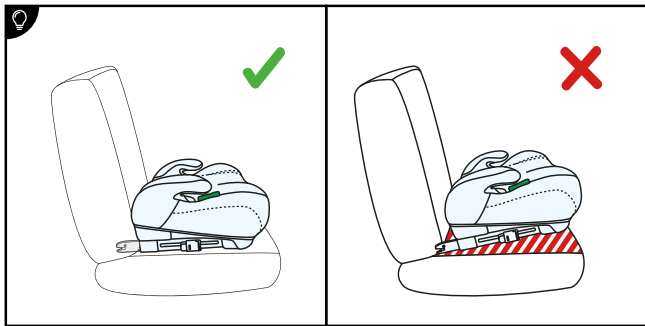

**IMPORTANT!** Make sure there are no gaps between the car seat and the vehicle seat.



**IMPORTANT!** To ensure your child's comfort, move the front vehicle seat as far forward as possible to provide room for your child's legs.

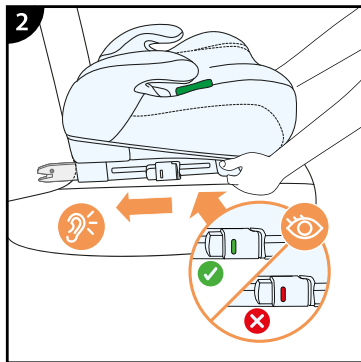
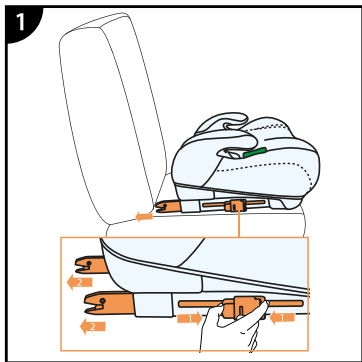

### 3.0 ISOFIX installation

1. Place the car seat on the vehicle seat. Press both sides of the ISOFIX release button and extend the ISOFIX connector arms to their maximum length.
2. Grasp the car seat with both hands and insert both latches into the places of installation on the vehicle seat. When you hear a "click" of each of the ISOFIX latches, push the seat of the car seat against the backrest of the vehicle seat, exerting firm even pressure on both sides.

**NOTE!** The locking latches are properly attached only when both button indicators are completely green.



Pay attention to the audible clicking sound of the ISOFIX connectors and grasp the car seat to check whether it is securely installed without any play. If it moves and the ISOFIX latches come out, repeat the previous steps.

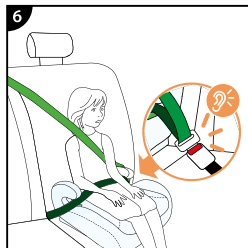
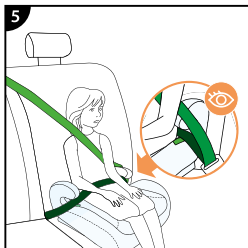
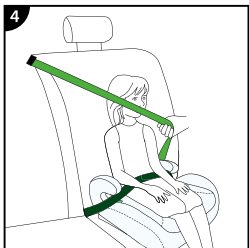
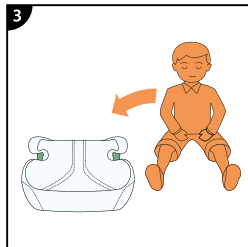
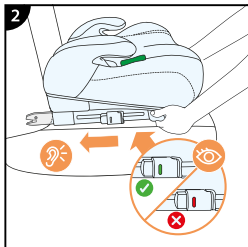
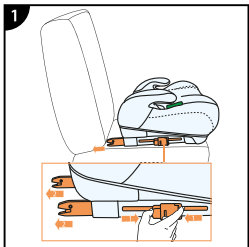

## 4.0 Installation of the car seat

Note! The car seat should be placed directly on the vehicle seat.

### 4.1 Children between 125 and 150 cm - using the ISOFIX connectors and a three-point car seat belt.

1. Install the car seat on the vehicle seat using ISOFIX connectors forward facing
2. Push the car seat all the way into the seat and check its correct installation – the colour of the indicators should change to green.
3. Place your child in the car seat
4. Pull the shoulder belt tight and guide it over your child's shoulder
5. Guide the car seat belt through both waist belt guides.
6. Fasten the car seat belt. You will hear a characteristic "click".

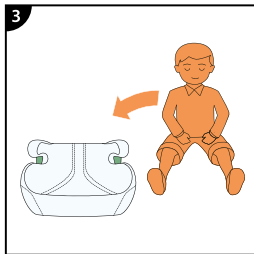
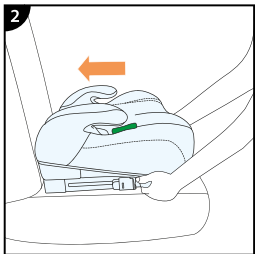
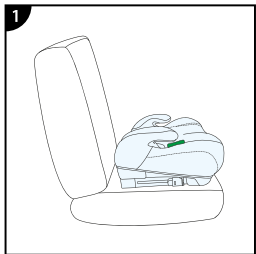

## 4.2 Children between 125 and 150 cm tall - using a three-point car seat belt.

1. Install the car seat forward facing on the vehicle seat.
2. Push the car seat all the way to the vehicle seat.
3. Place your child in the car seat
4. Pull the shoulder belt tight and guide it over your child's shoulder
5. Guide the car seat belt through both waist belt guides.
6. Fasten the car seat belt. You will hear a characteristic "click".

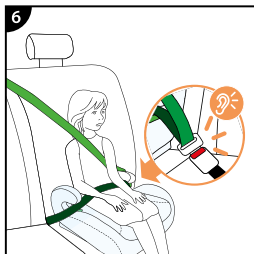
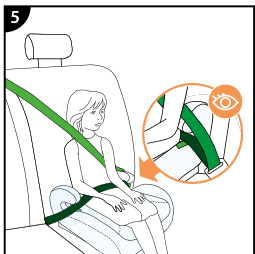
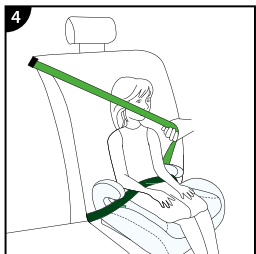

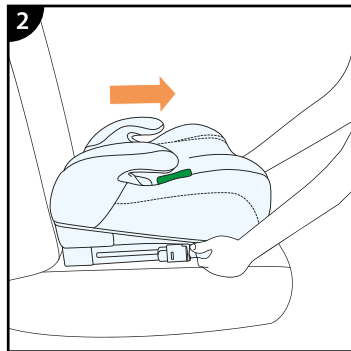
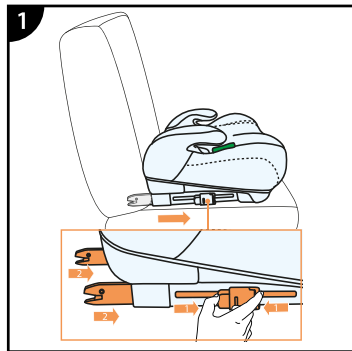

## 5.0 Removing the car seat (ISOFIX installation system)

1. Press the release button on both ISOFIX latches. (The latches will be released, and the colour of the ISOFIX indicators will change from green to red)
2. Insert the ISOFIX arms into the base of the car seat.

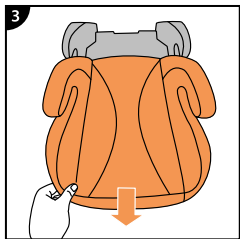
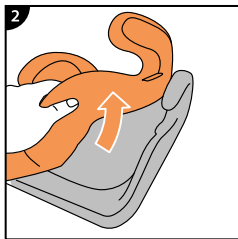
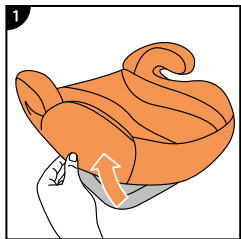

## 5.1 Removing the cover

1. Starting at the bottom of the car seat, carefully remove the cover on both sides of the car seat
2. Pull the fabric off the armrests
3. Remove the fabric completely from the car seat by pulling it towards you

## 5.2 Installing the cover

To put the cover back on - just reverse the above sequence of actions. Align the cover with the attachment points on the car seat.

## 6.0 Cleaning

NOTE! The car seat must not be used without the cover.

- The cover is removable and washable with a mild powder and using a program for delicate fabrics (30°C).
- Follow the washing instructions on the cover information label. The colours may fade if it is washed at the temperature above 30°C. The cover should not be centrifuged or dried in a tumble dryer (which may lead to separation of the material layers).
- Prolonged sun exposure of the cover is prohibited.
- Plastic parts can be cleaned with soap and water.
- Do not use aggressive cleaning agents (such as solvents).
- The safety harness can be cleaned in lukewarm soapy water.

Warning! You must not remove the metal clips from the safety harness.

The full text of the Warranty Terms and Conditions is available on the website [WWW.KINDERKRAFT.COM](http://WWW.KINDERKRAFT.COM)



**(AR)** بضمان مصلحة عملائنا. نحن في خدمتكم! إذا كانت لديكم أي مشكلة مع المنتج الذي حصلتم عليه، فيجربى الاتصال بنا بالطريقة التي تفضلونها!

**(CS)** V zájmu péče o naše klienty - jsme rádi k dispozici! Pokud jste se setkali s nějakým problémem v souvislosti s obdržným výrobkem, kontaktujte nás způsobem, který vám nejlépe vyhovuje!

**(DE)** In Sorge für unsere Kunden - stehen wir gerne zu Ihrer Verfügung! Wenn Sie auf ein Problem mit dem erhaltenen Produkt treffen, treten Sie bitte mit uns in Kontakt in der bequemsten Weise für Sie!

**(EN)** In the interests of our Clients - we are at your disposal! If you have a problem with the product you received, contact us in the most convenient way for you!

**(ES)** ¡Por el bien de nuestros clientes, estamos a su disposición! ¡Si tiene cualquier problema con el producto recibido, póngase en contacto con nosotros de forma más cómoda para usted!

**(FR)** Dans l'intérêt de nos clients - nous sommes à votre disposition! Si vous avez un problème avec le produit que vous avez reçu, contactez-nous de la manière la plus pratique pour vous!

**(HU)** Bármikor állunk az ügyfeleink rendelkezésére! Ha az átvett termékkel kapcsolatban valamilyen problémába ütközött, az Önnek legmegfelelőbb módon vegye fel velünk a kapcsolatot!

**(IT)** Prendersi cura dei nostri Clienti - siamo alla Vostra disposizione! Se hai incontrato un problema con il prodotto che hai ricevuto. Contattaci nel modo piu conveniente per te!

**(NL)** In het belang van onze klanten - staan wij ter beschikking! Als u een probleem met het ontvangen product tegenkomt, neemt contact met ons op via de manier die u het makkelijkste vindt!

**(PL)** W trosce o naszych Klientów - jesteśmy do dyspozycji! Jeśli napotkałeś problem dotyczący otrzymanego produktu, skontaktuj się z nami w najbardziej dogodny dla Ciebie sposób!

**(PT)** Para o conforto dos nossos Clientes - estamos sempre à sua disposição! Se tiver qualquer problema com o nosso produto, entre em contacto conosco de modo mais confortável para si!

**(RO)** In interesul clienților noștri - suntem la dispoziția dumneavoastră! Dacă aveți o problema cu produsul pe care l-ați primit, contactați-ne în modul cel mai convenabil pentru dvs.!

**(RU)** заботясь о наших клиентах, мы находимся в вашем распоряжении. Если вы столкнулись с проблемой, связанной с полученными продукто, свяжитесь с нами наиболее удобным для вас способом!

**(SK)** Náš zákazník je pre nás dôležitý - sme vám k dispozícii! Ak máte akýkoľvek problém súvisiaci s doručeným produktom, kontaktujte nás spôsobom, ktorý vám najviac vyhovuje!

**(SV)** I våra kundens intresse - vi står till ditt förfogande! Om du har problem med den produkt du fick, kontakta oss på det mest praktiska sättet för dig!

### International contact:

support@kinderkraft.com

+44 20 4525 0748



kinderkraftofficial



kinderkraft



kinderkraftofficial

منتج / VÝROBCE / HERSTELLER / MANUFACTURER / FABRICANTE / FABRICANT /  
GYARTÓ / FABBRICANTE / FABRIKANT / PRODUCTENT / FABRICANTE / PRODUCĂTOR /  
ПРОИЗВОДИТЕЛЬ / VÝROBCA / TILLVERKARE:

**4Kraft Sp. z o.o. ul. Tatrzańska 1/5  
60-413 Poznań, Poland**