

Modell: SONORA 56

- Ⓛ Montageanleitung
- Ⓝ Handleiding voor de montage
- Ⓜ Montaj talimatı
- Ⓧ Notice de montage
- Ⓒ Montážní návod
- Ⓜ Szerelési útmutató
- Ⓜ Assembly instructions
- Ⓜ Instrukcja montażu
- Ⓜ Инструкция по монтажу
- Ⓜ Istruzioni di montaggio
- Ⓜ Návod na montáž
- Ⓜ Instrucțiuni de montaj
- Ⓜ Instrucciones de montaje
- Ⓜ Montaj Talimatı

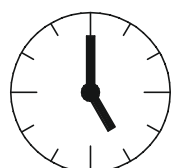

2 h

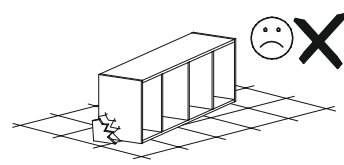
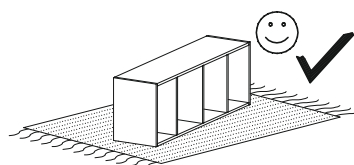
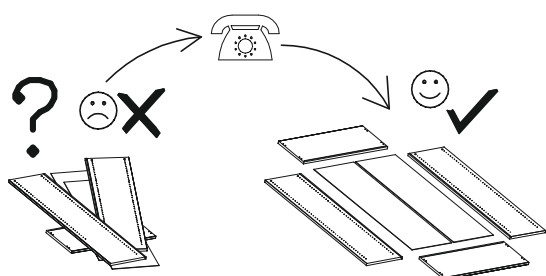
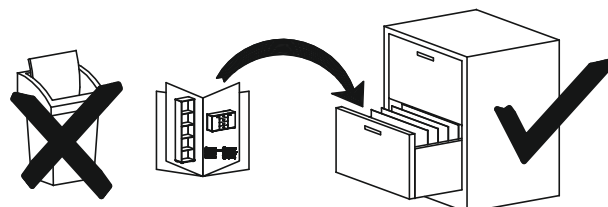
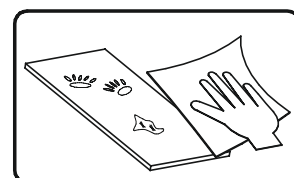
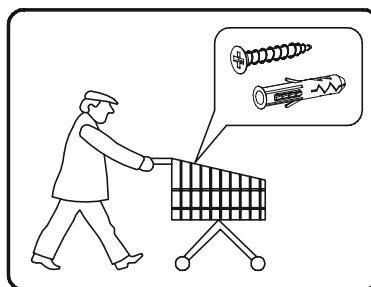
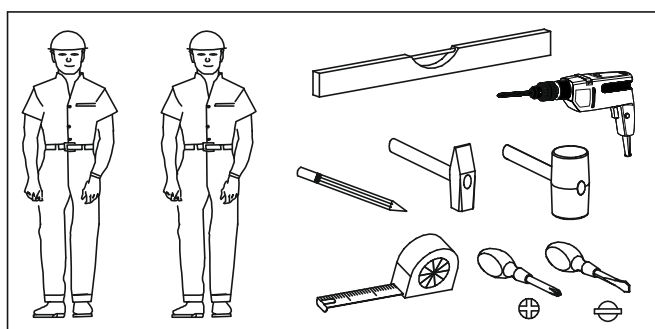
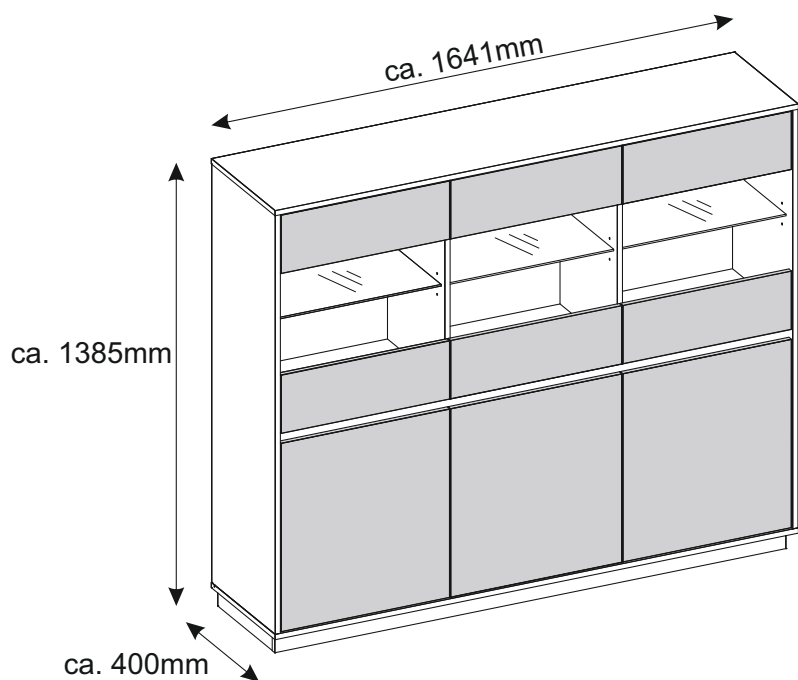
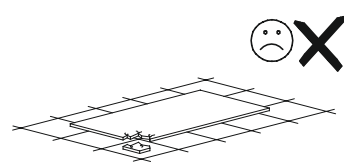
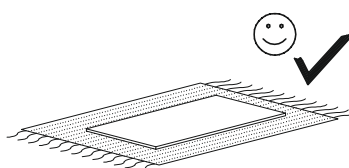

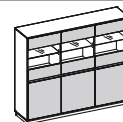





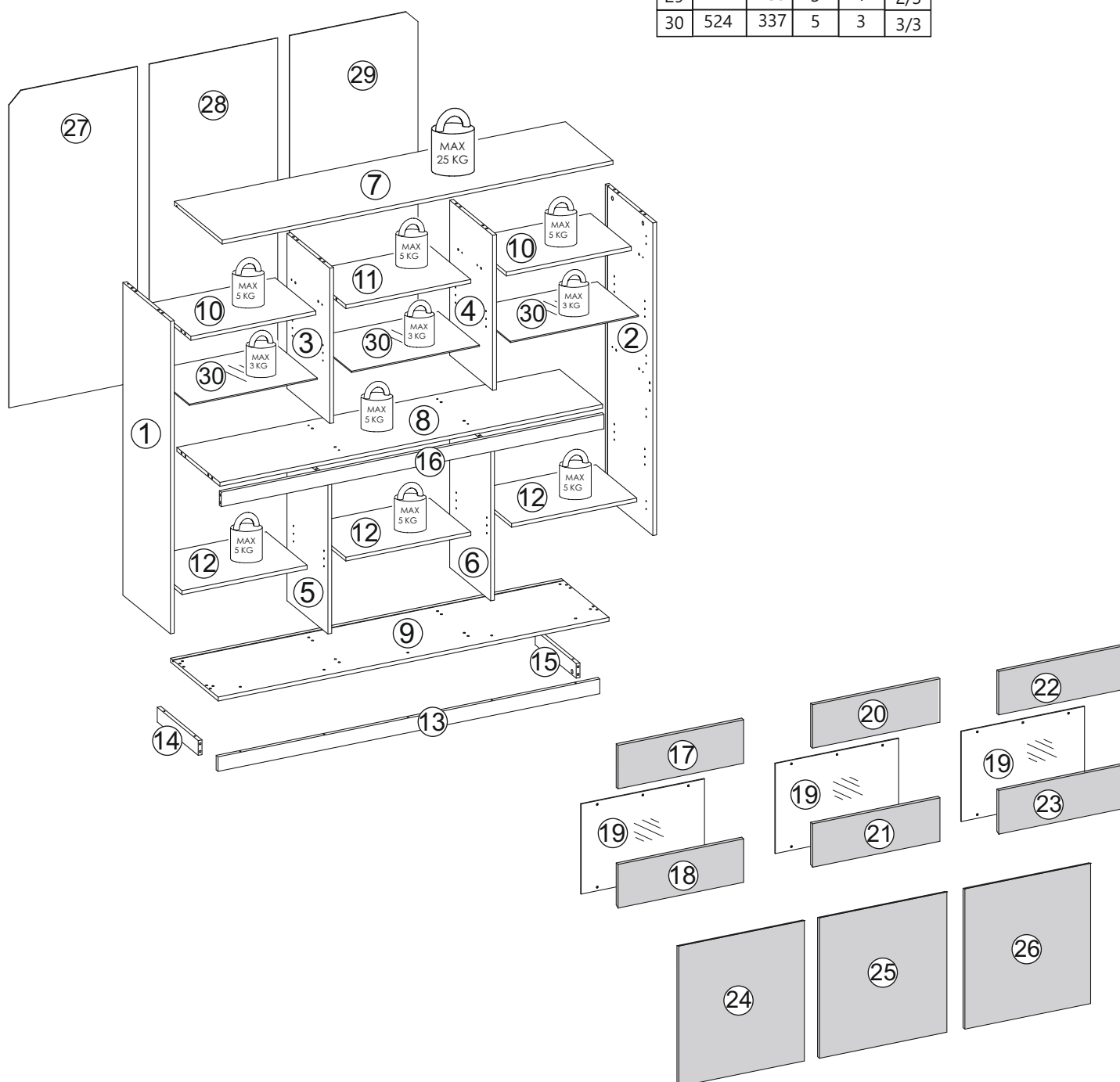

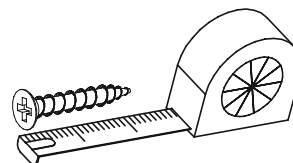
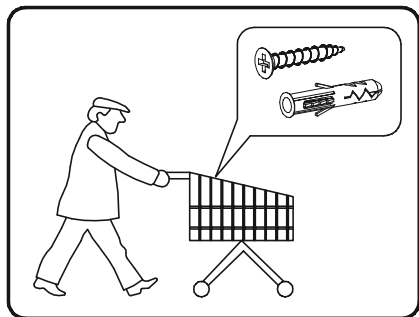
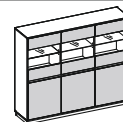





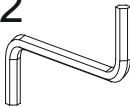

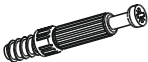

nr	L[mm]	B[mm]	T[mm]	Menge	Colli
1	1288	399	16	1	1/3
2	1288	399	16	1	1/3
3	639	360	16	1	1/3
4	639	360	16	1	1/3
5	633	344	16	1	1/3
6	633	344	16	1	1/3
7	1641	400	16	1	2/3
8	1607	361	16	1	2/3
9	1641	400	16	1	2/3
10	525	343	16	2	2/3
11	525	343	16	1	2/3
12	525	343	16	3	1/3
13	1603	60	16	1	2/3
14	344	60	16	1	1/3

nr	L[mm]	B[mm]	T[mm]	Menge	Colli
15	344	60	16	1	1/3
16	1607	60	16	1	2/3
17	529	180	16	1	3/3
18	529	180	16	1	3/3
19	519	372	4	3	3/3
20	537	180	16	1	3/3
21	537	180	16	1	3/3
22	529	180	16	1	3/3
23	529	180	16	1	3/3
24	580	529	16	1	3/3
25	580	537	16	1	3/3
26	580	529	16	1	3/3
27	1298	539	3	1	2/3
28	1298	539	3	1	2/3
29	1298	239	3	1	2/3
30	524	337	5	3	3/3

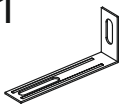
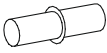
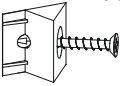

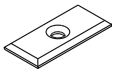
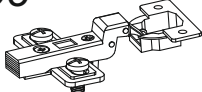
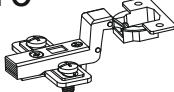

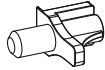

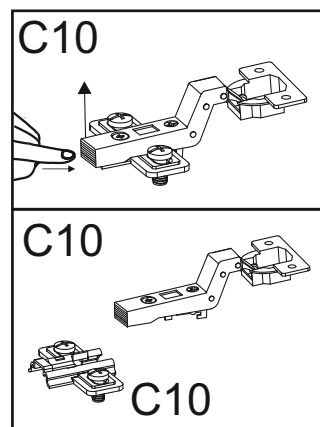
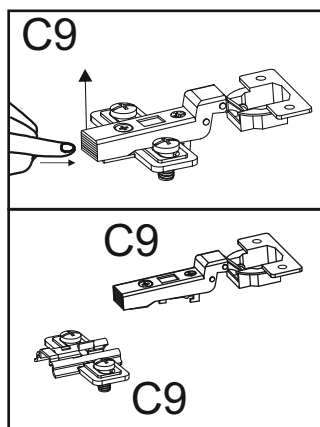

B1 3003605  ø8x35 x30	B3 3004567  ø8x60 x8	A1 3000534  ø7x50 x17	W2 3000331  x1	K1 3001728  15x12 x34
K10 3002942  x34	G26 3000574  3,5x16 x26	G48 3000564  6,3x13 x4	G49 3005411  4x16 x18	G50 3003843  3x20 x34
I8  x33	F13 3005328  x2	M11 3002892  x2	F2 3000545  x12	I1 3000344  x10
F20 3004583  x18	Z6 3002435  x16	C9 3015878  x4	C10 30115877  x8	P4 3000406  x7
F4 3001455  x12				

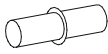

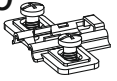



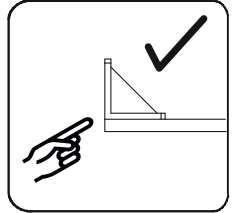
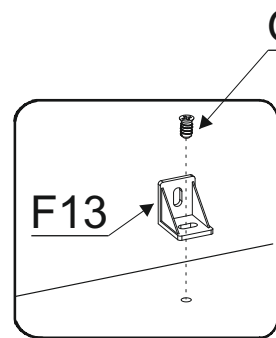
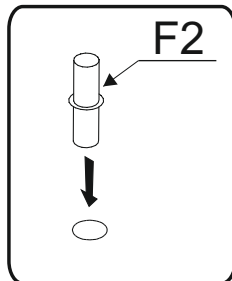
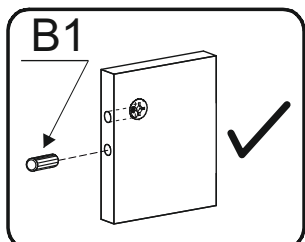
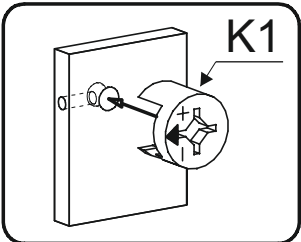
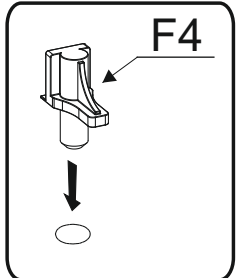
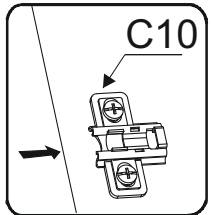
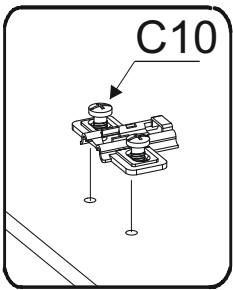
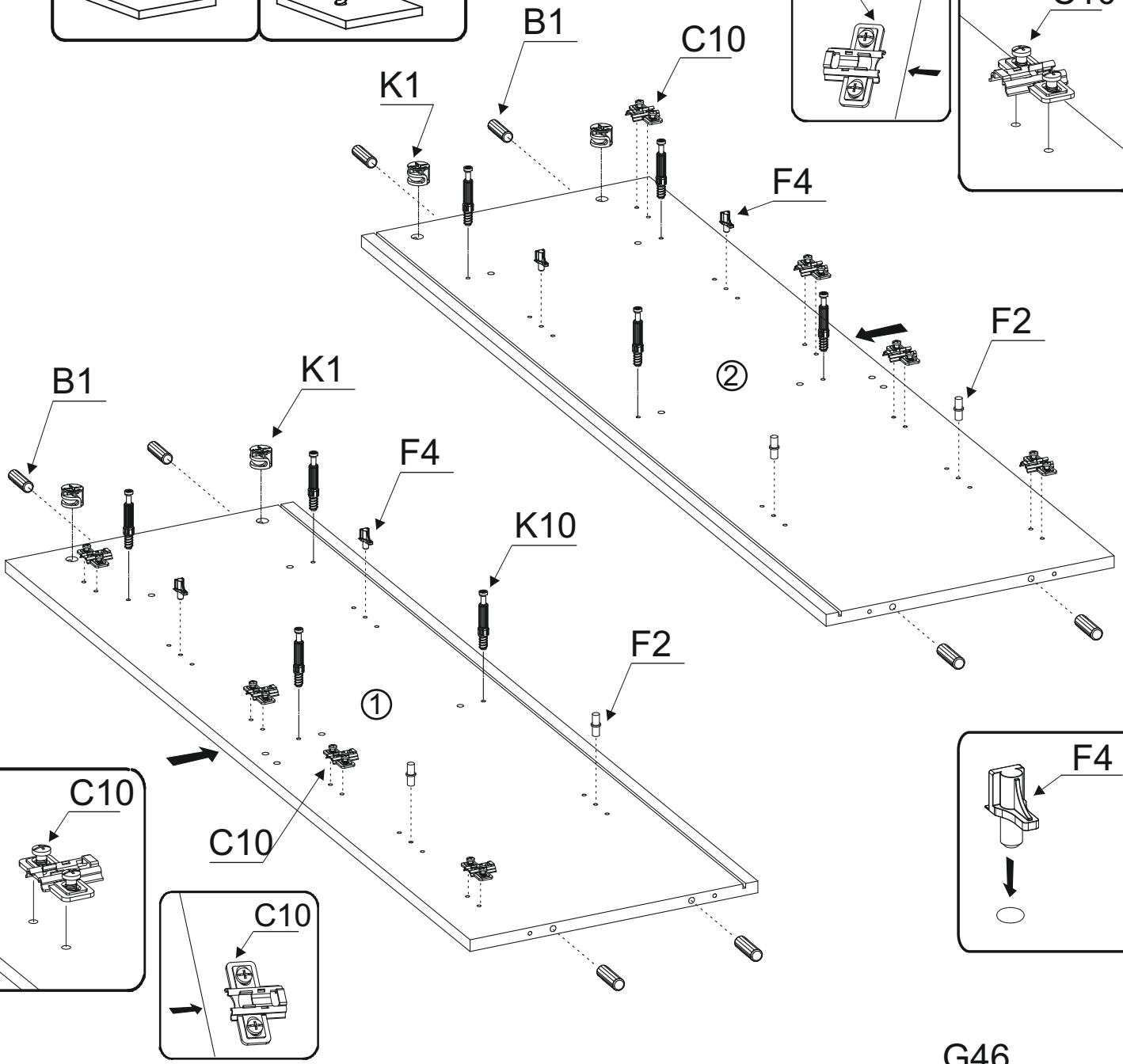
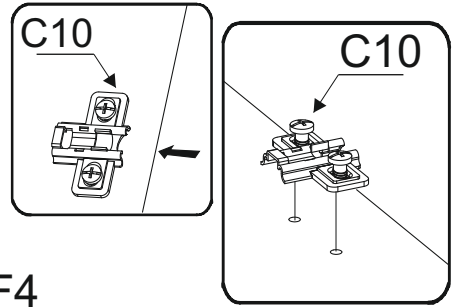
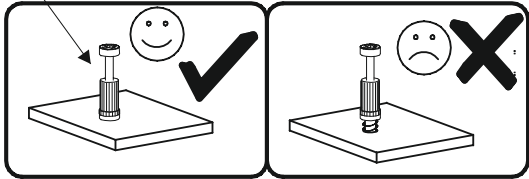

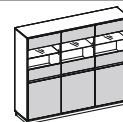
F2  x4	B1  ø8x35 x8	K1  x4	C10  x8
K10  x8	F4  x4		



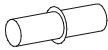

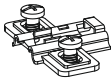
II

F2  x8	B1  ø8x35 x4	K1  x4	C9  x2
		G46  6,3x9,5 x2	F13  x2

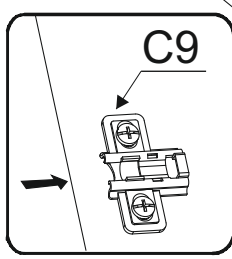
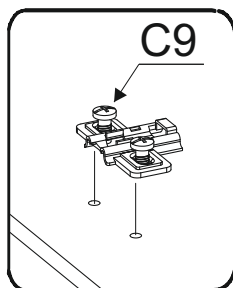
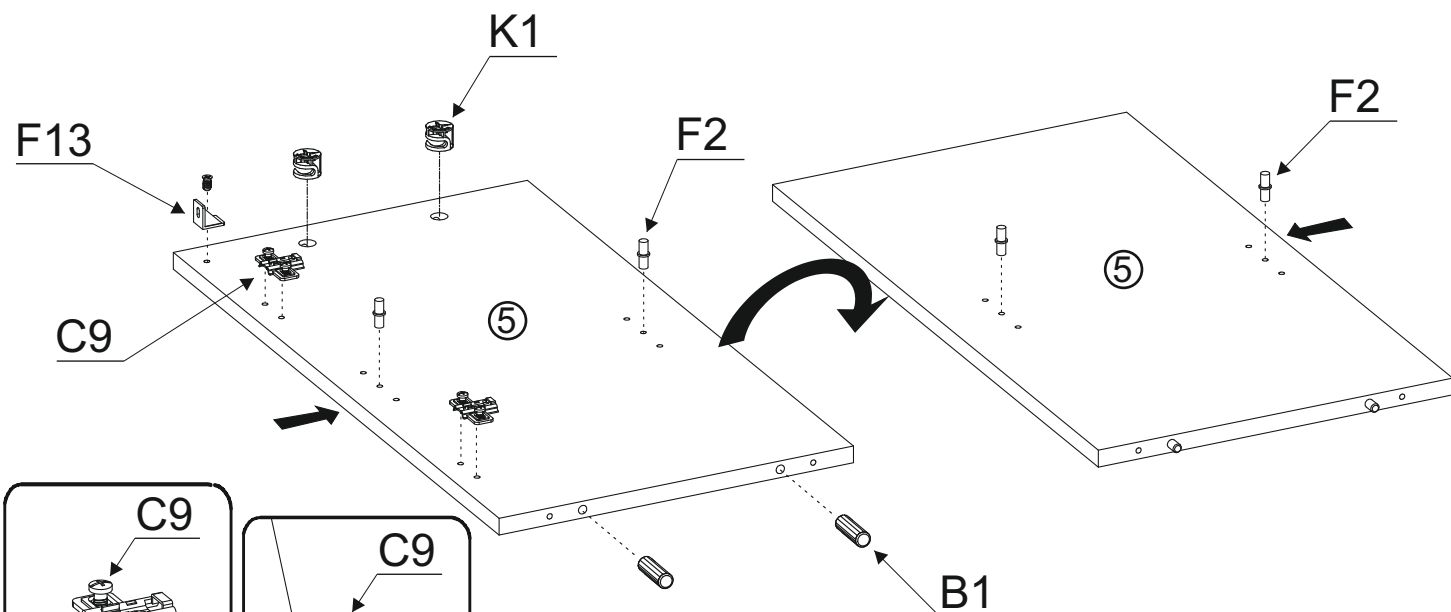

K1

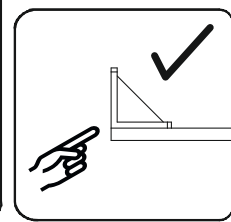
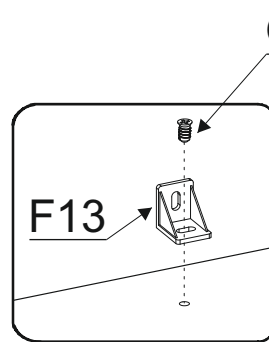
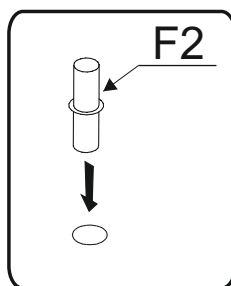
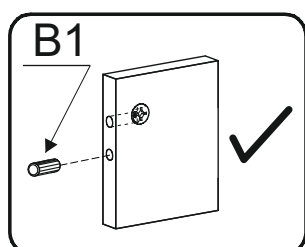
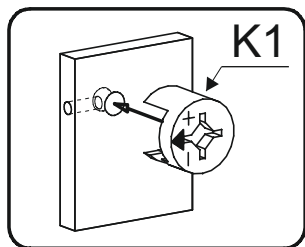
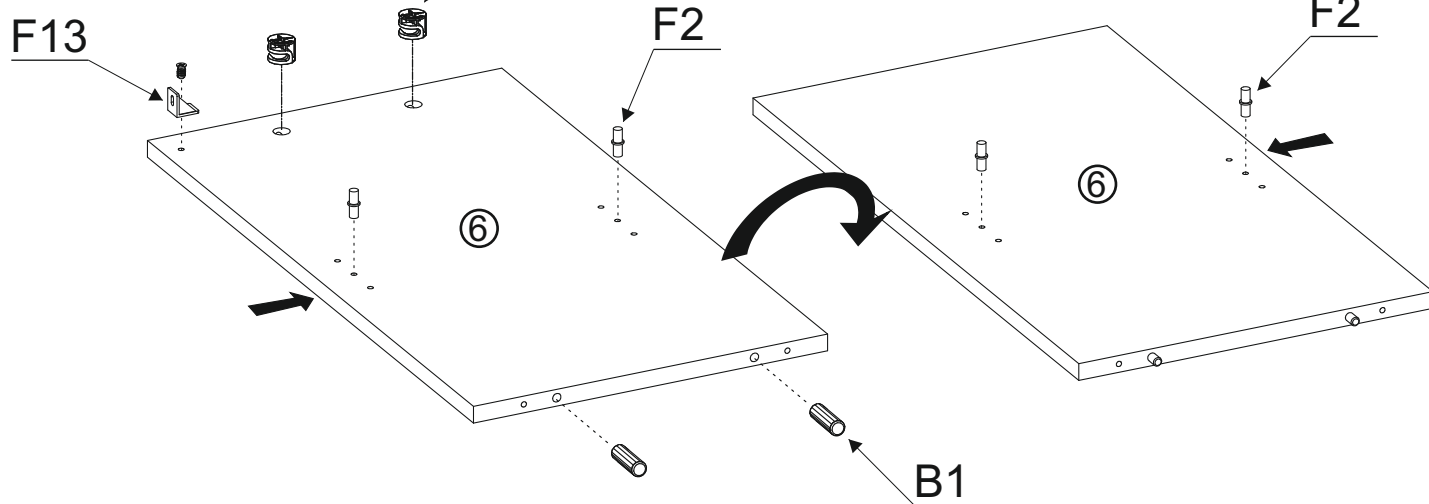



III

B1
ø8x35
x4



B3
ø8x60
x4



C9
x2

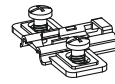

K1
x8



F4
x8

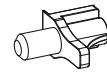

K10
x8

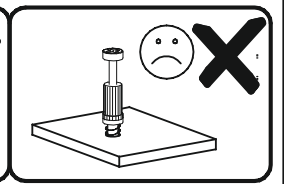
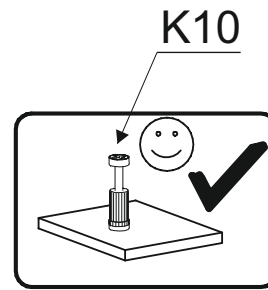
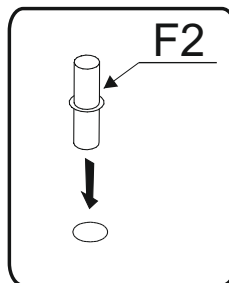
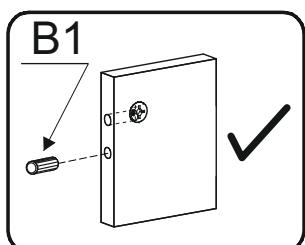
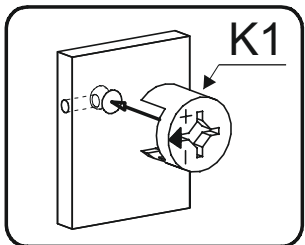
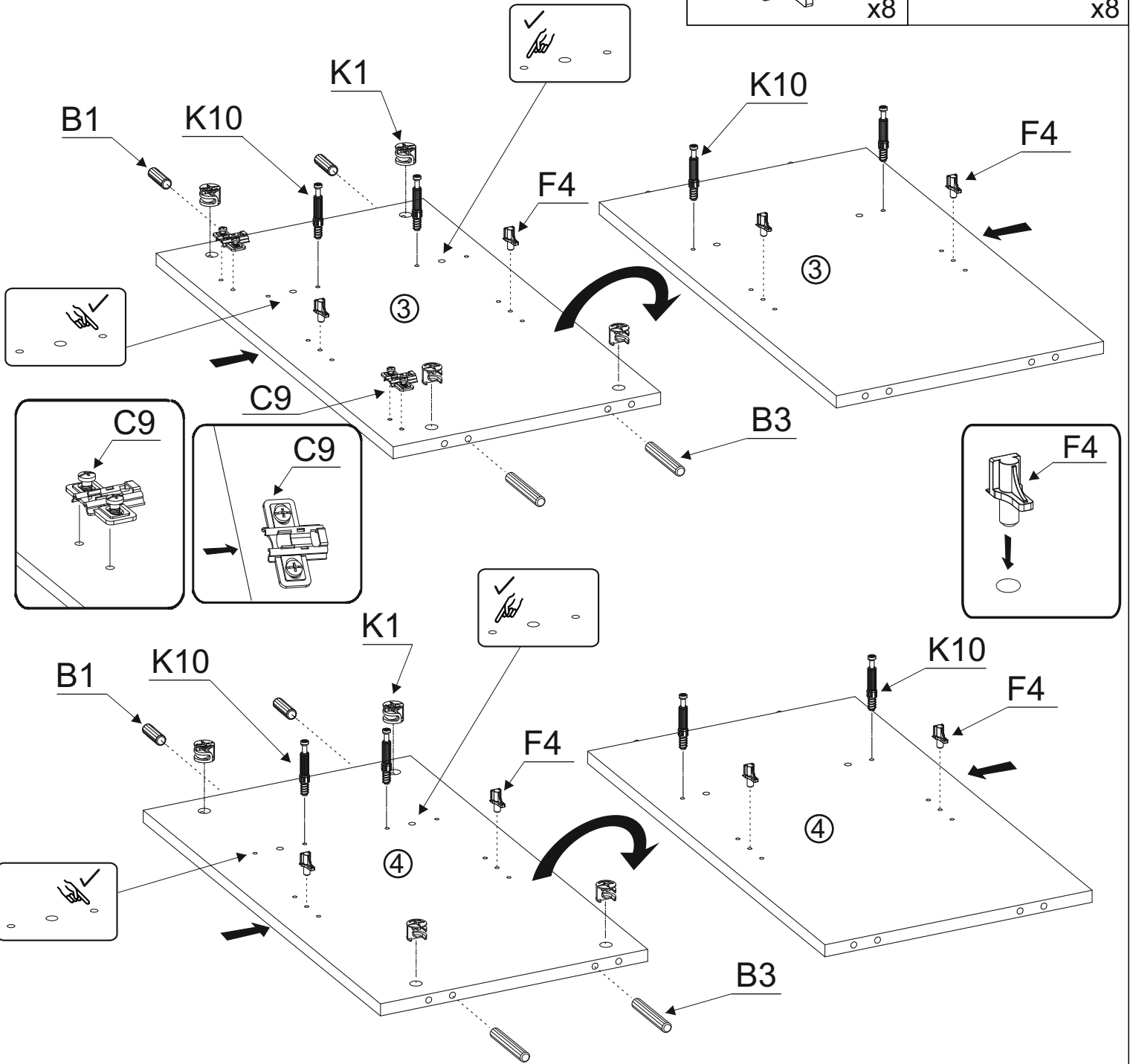



IV

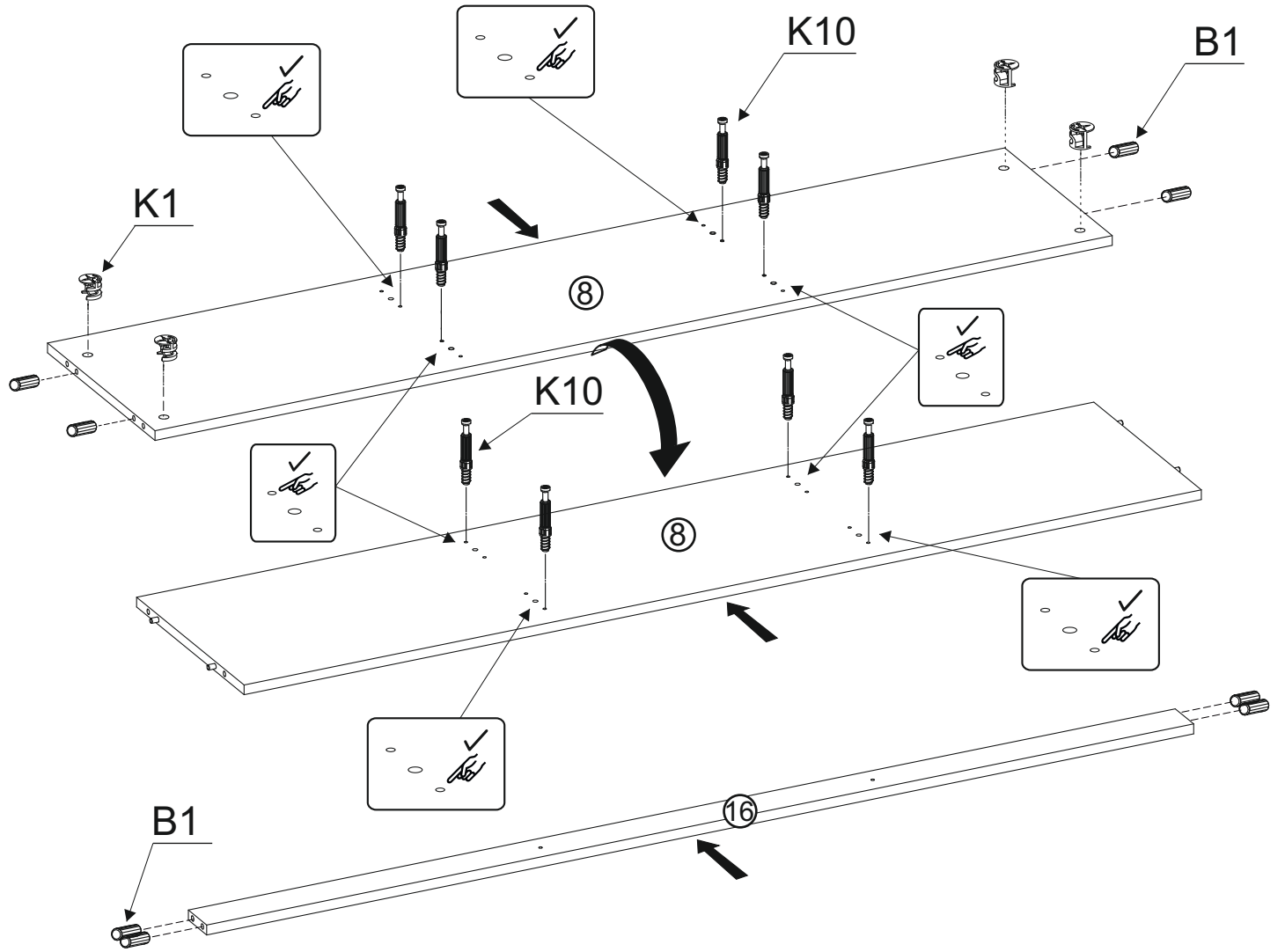
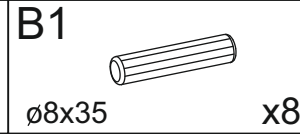
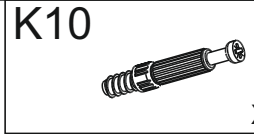

V

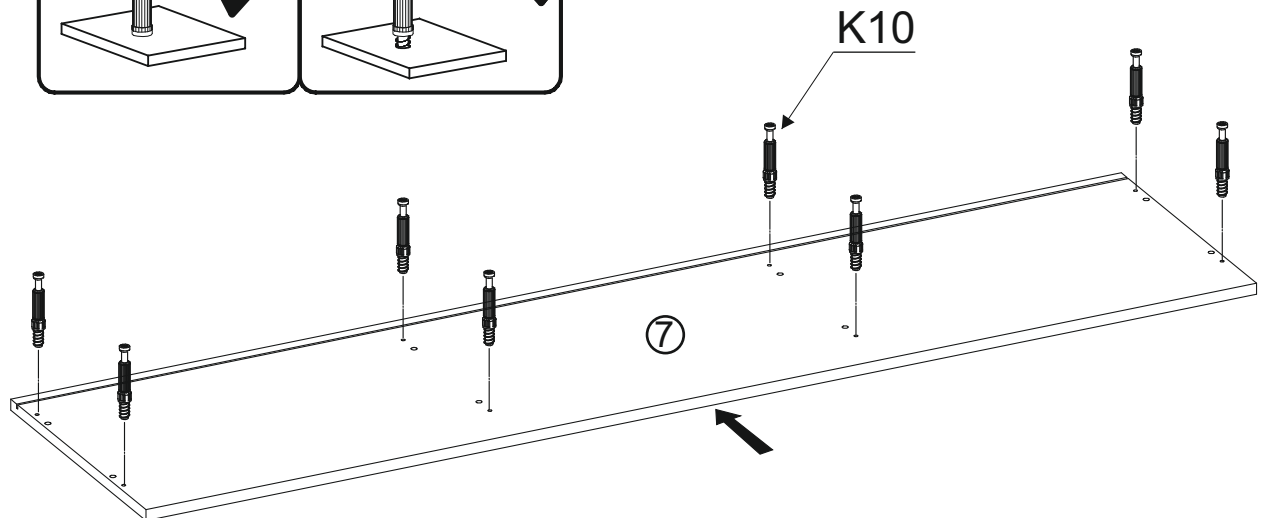
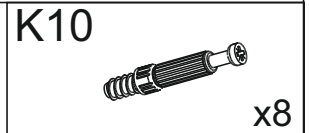
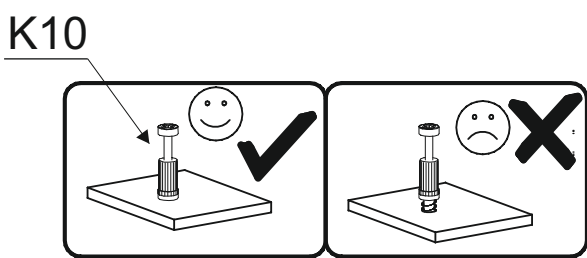

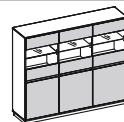

VI

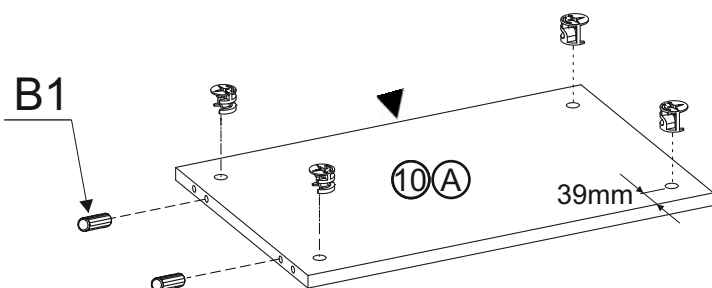
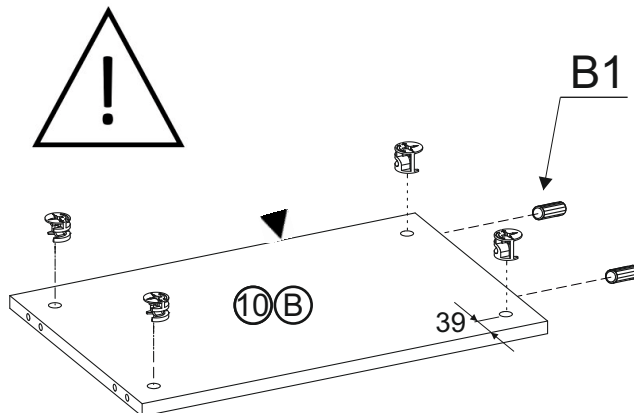
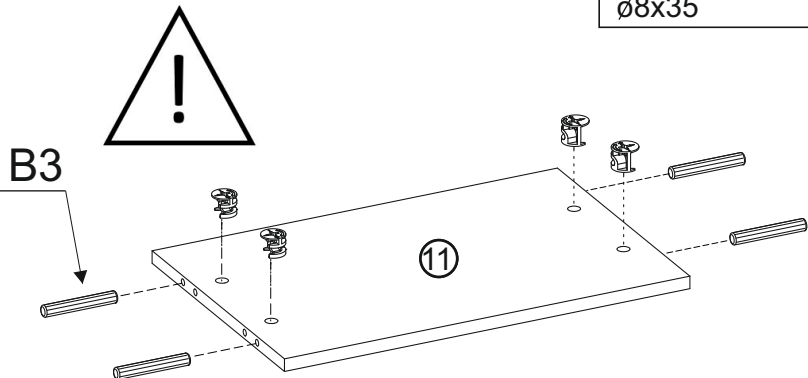
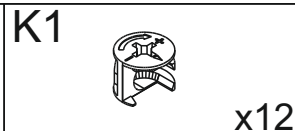
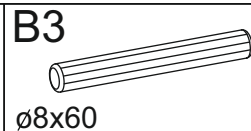
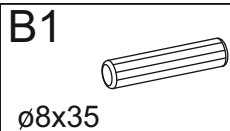

VII

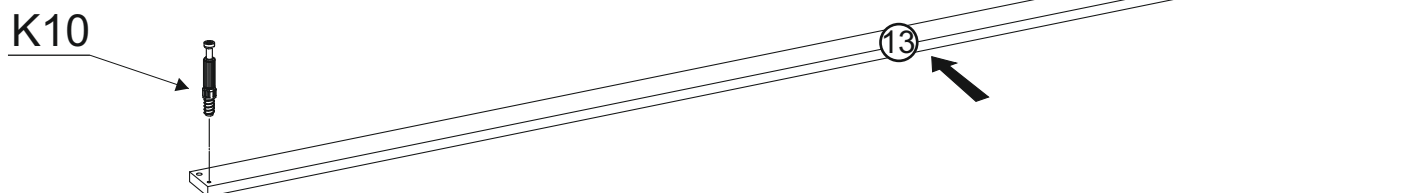
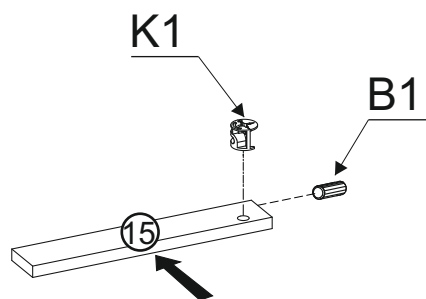
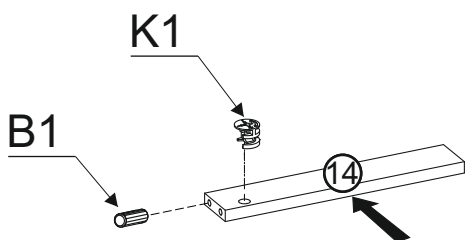
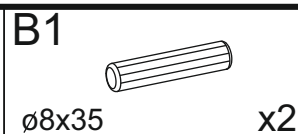
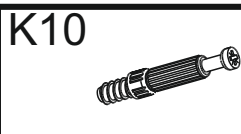



VIII

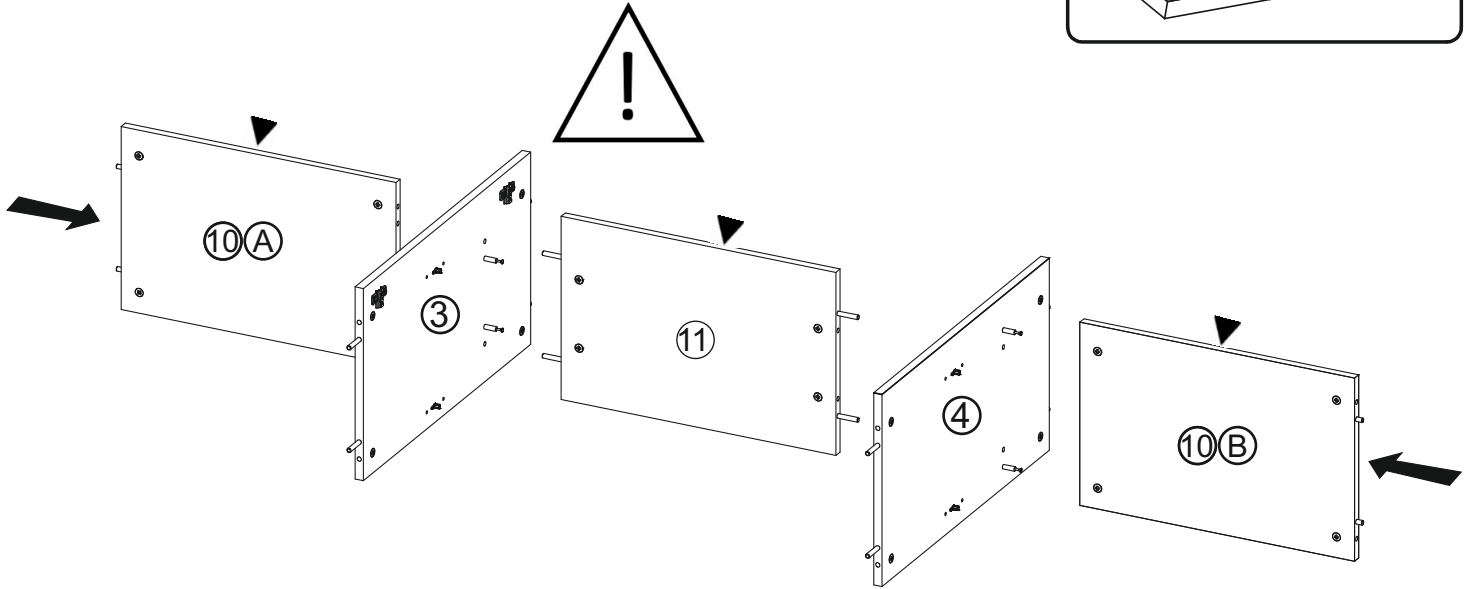
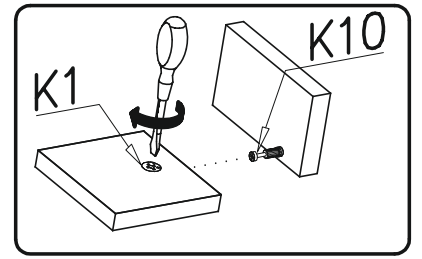

IX

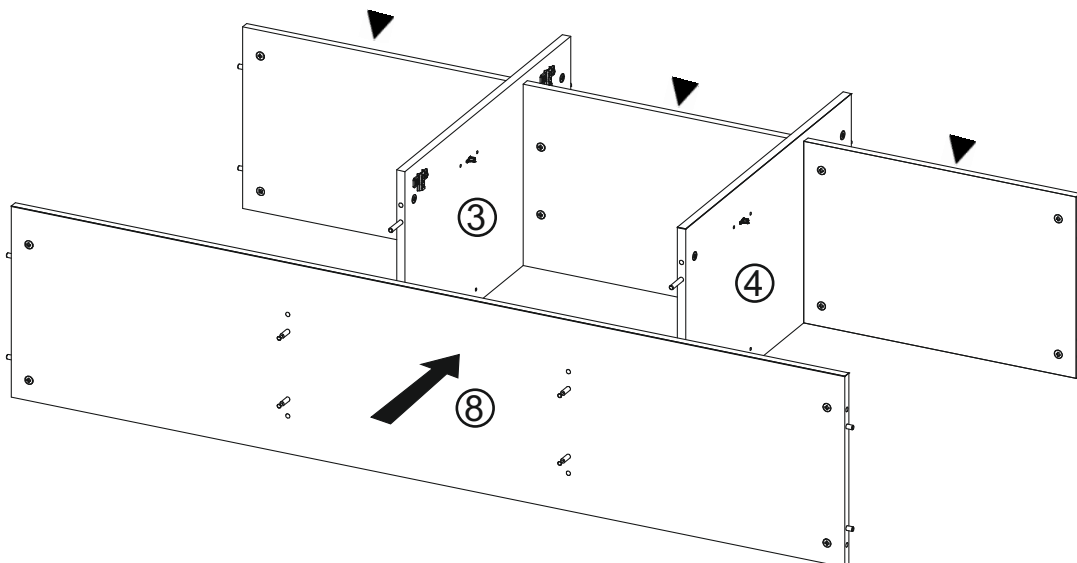
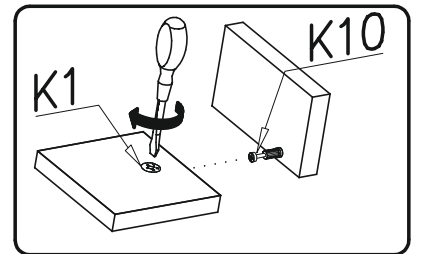

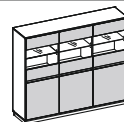

X

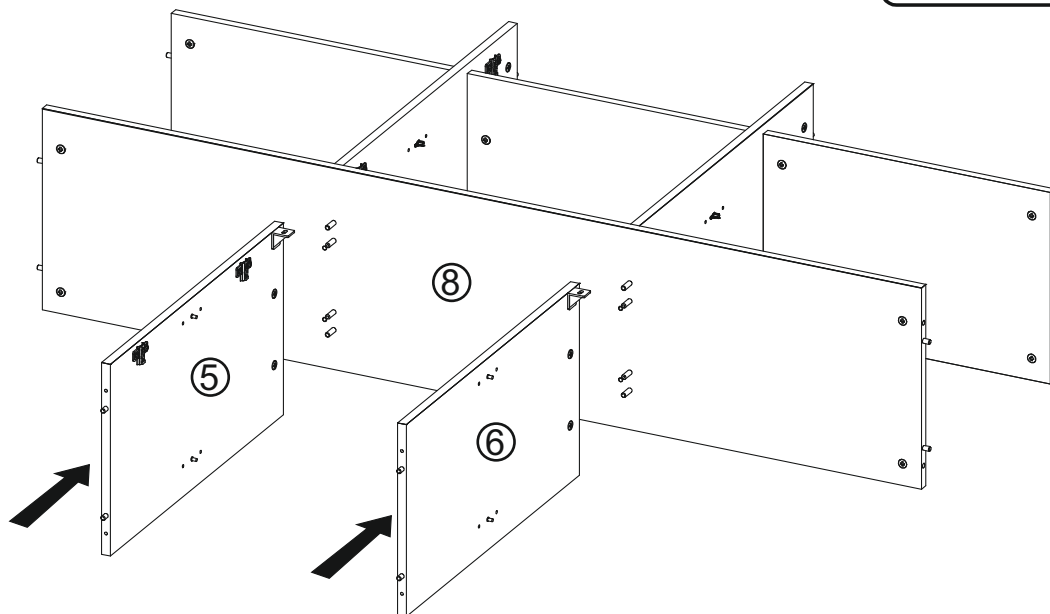
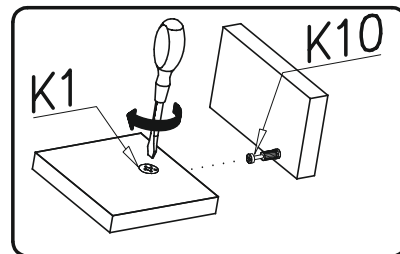

XI

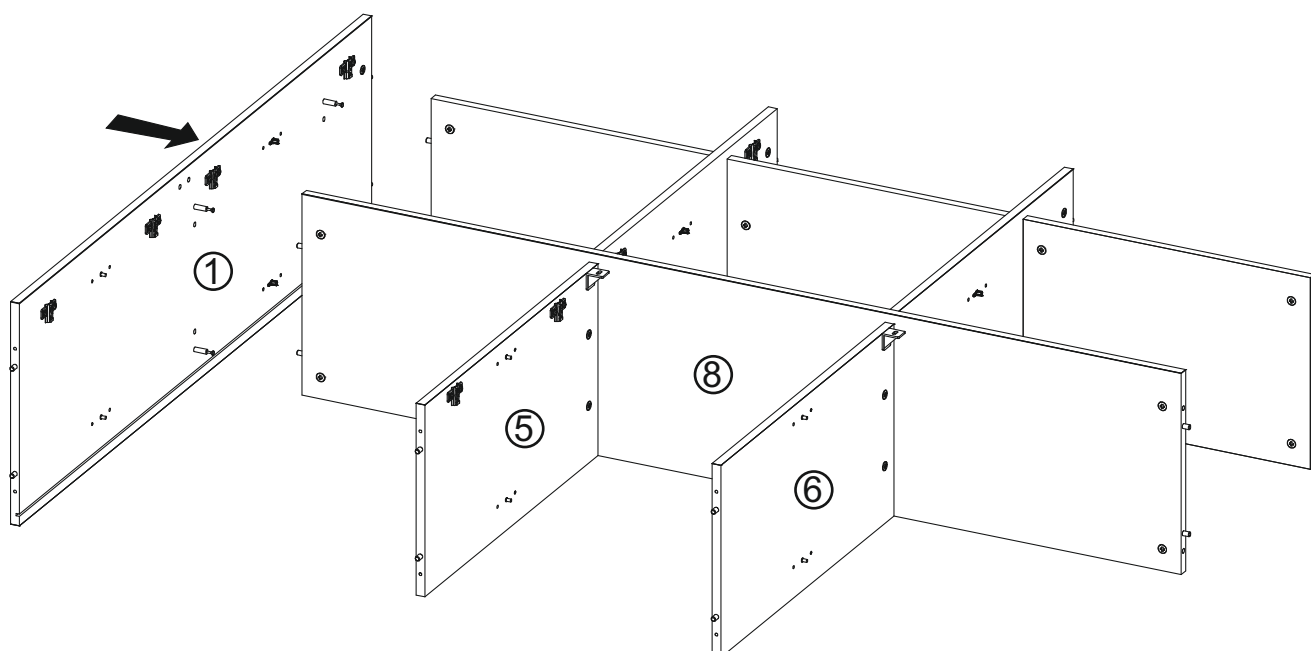
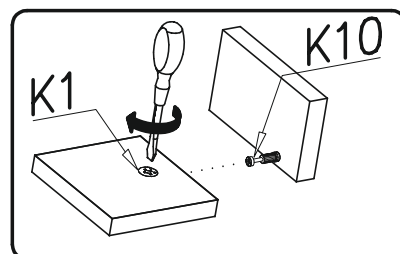

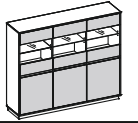

XII

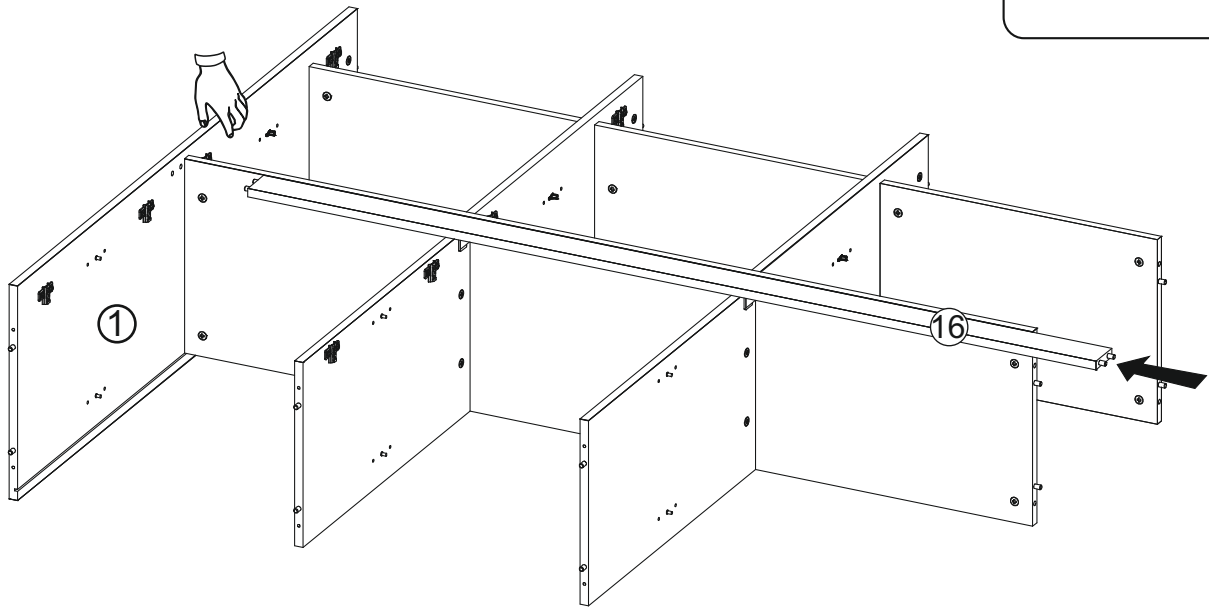

XIII

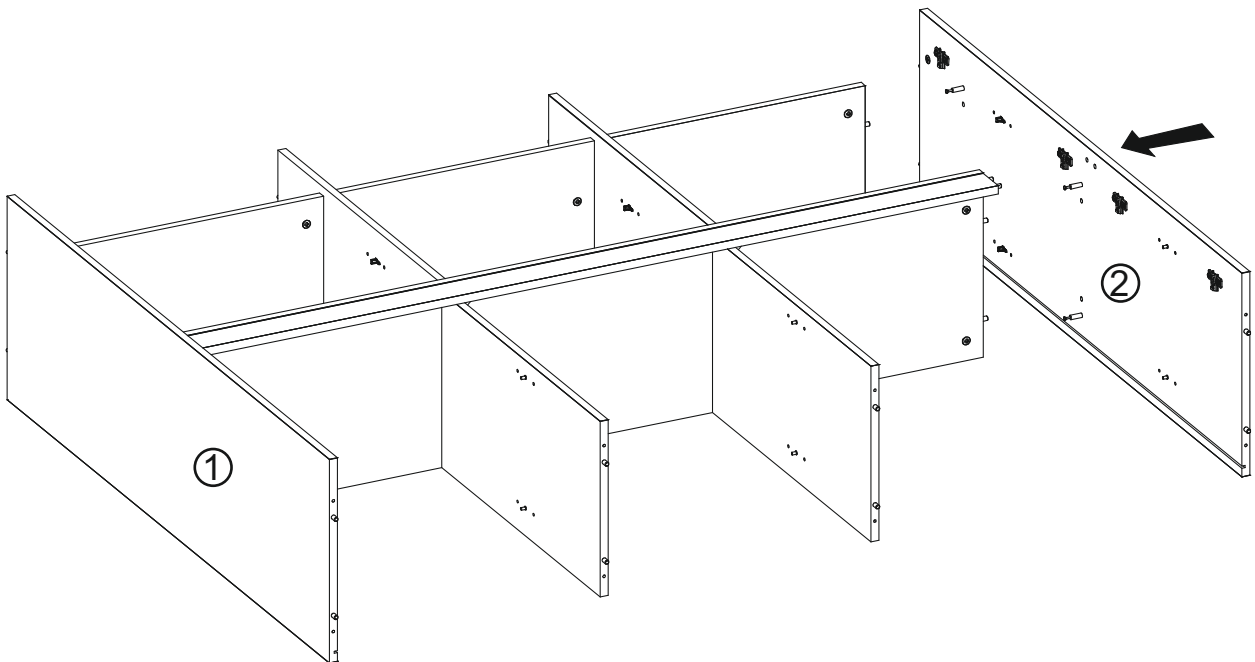
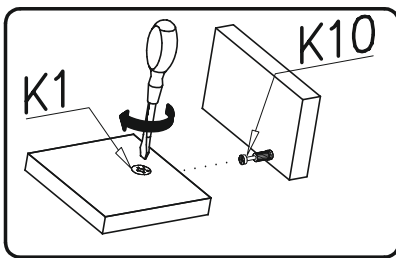



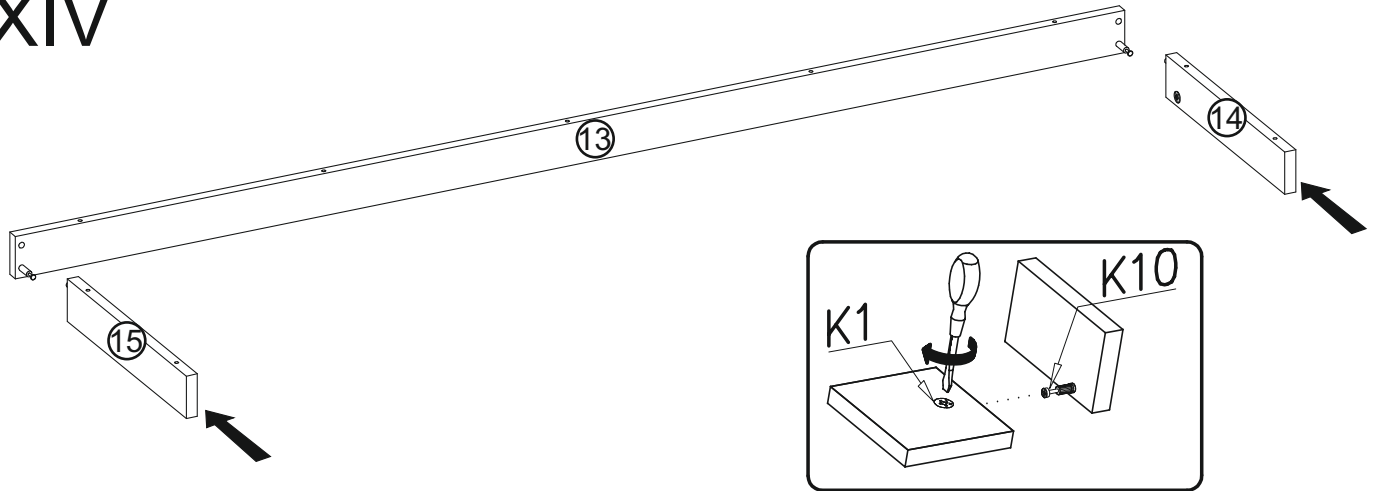

XIV

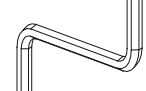

XV

- | | | |
|---|---|---|
| <p>A1</p>  <p>o7x50 x9</p> | <p>W2</p>  <p>x1</p> | <p>P4</p>  <p>x7</p> |
|---|---|---|

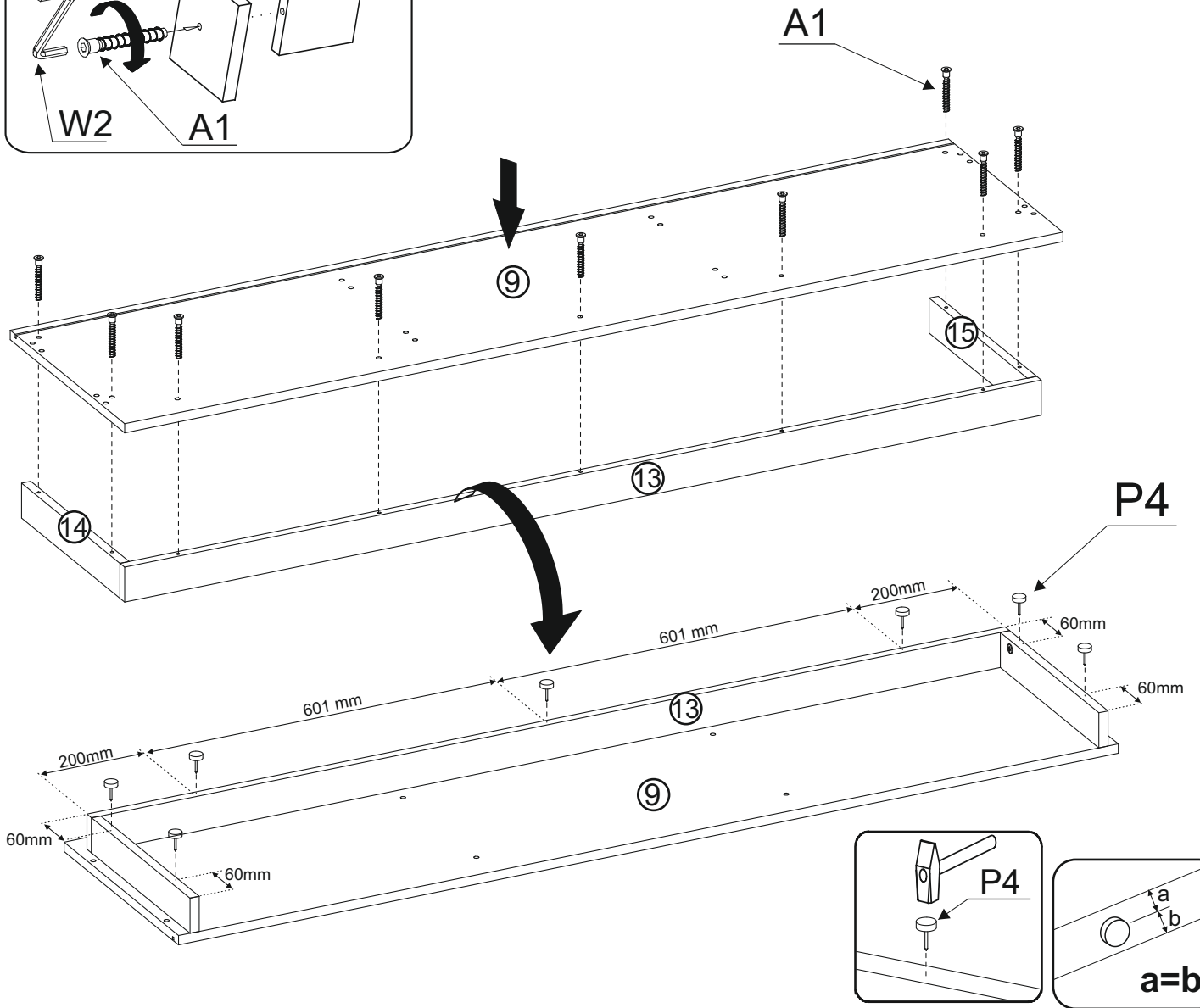
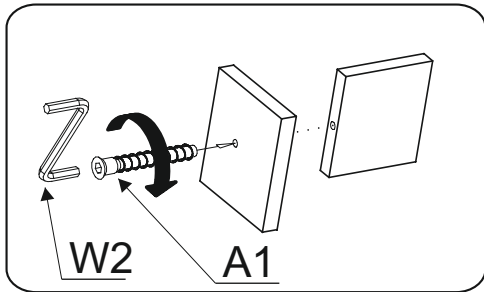

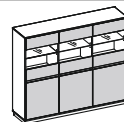

XVI

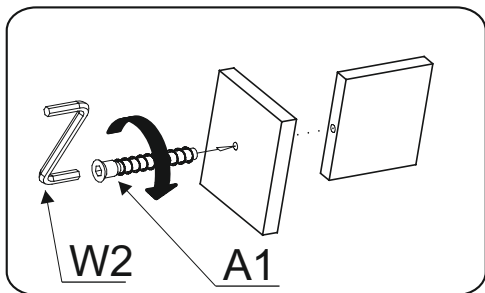

A1



o7x50

x8

W2

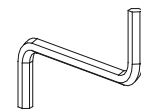

x1

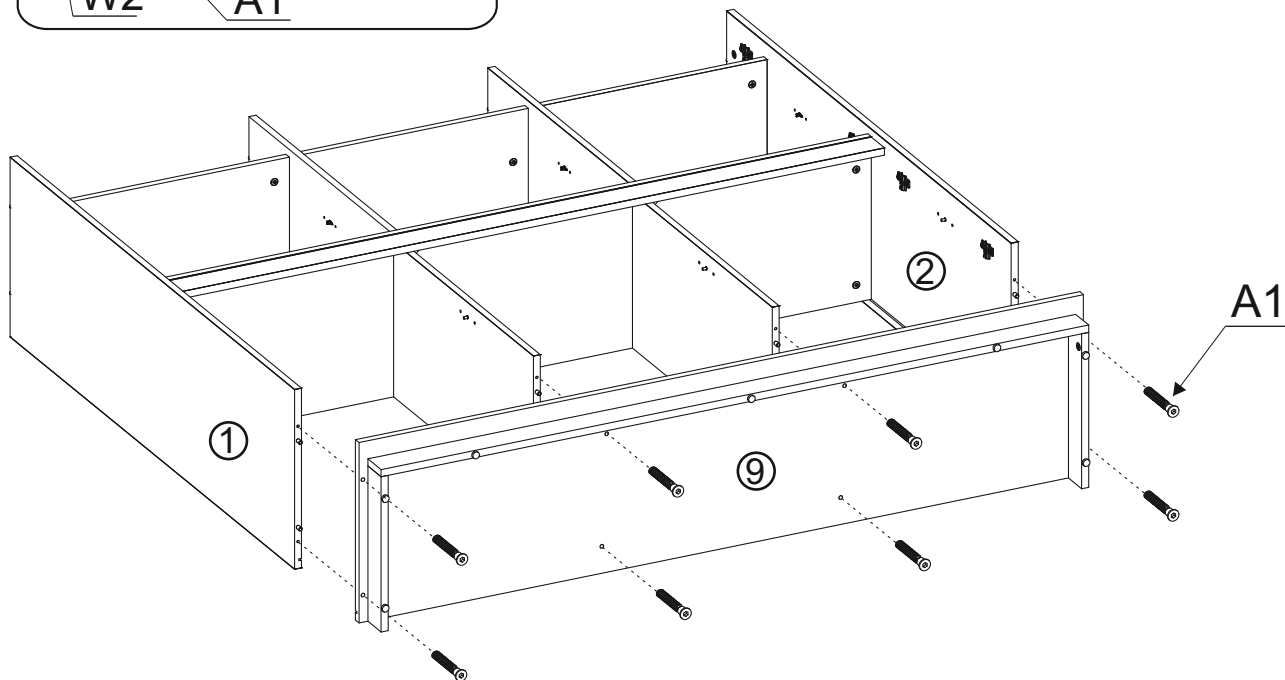

XVII

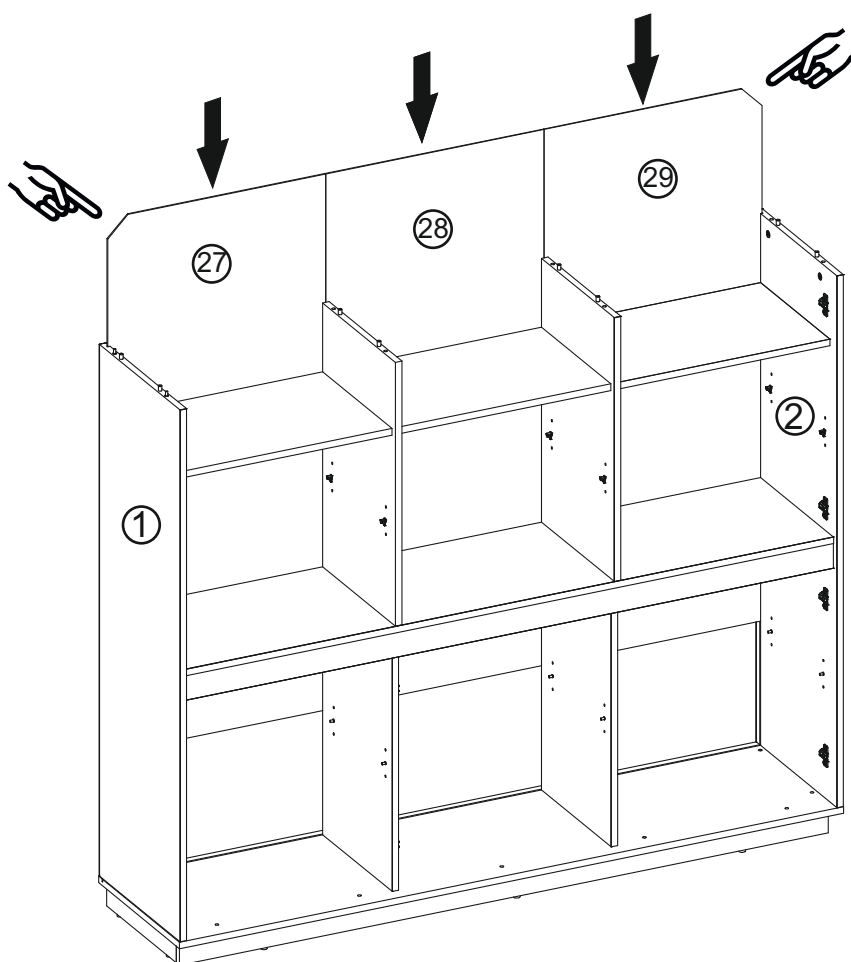



XVIII

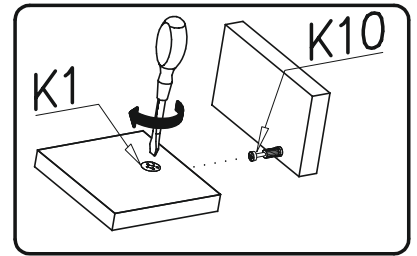
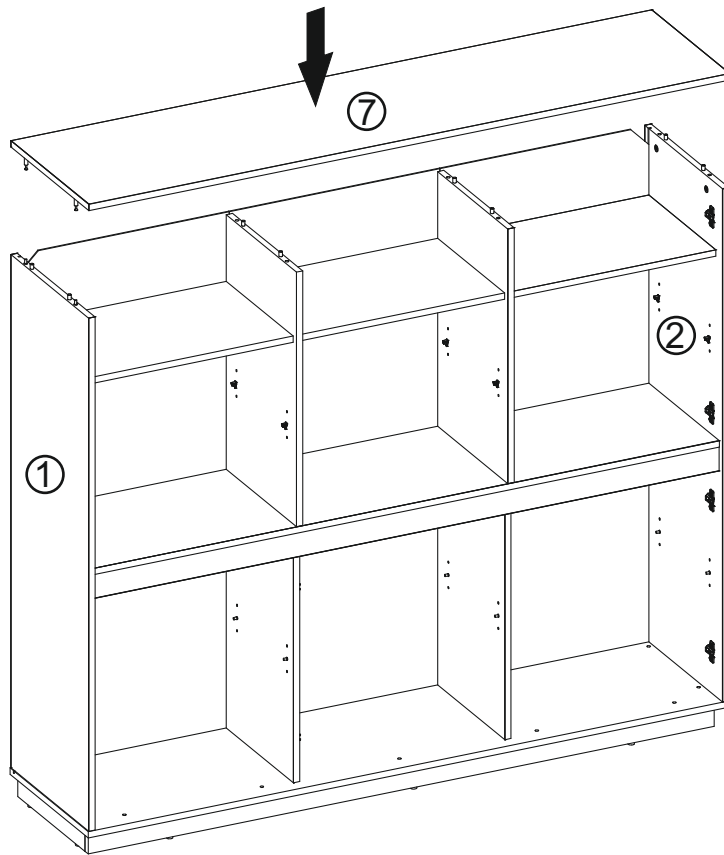

XIX

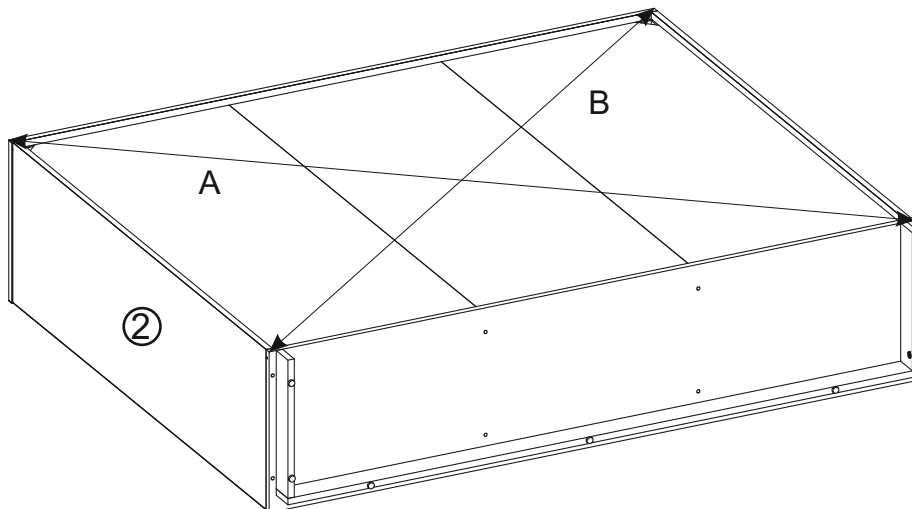
 $A=B$ 



XX

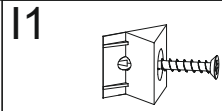

x10



3x20

x34



x16

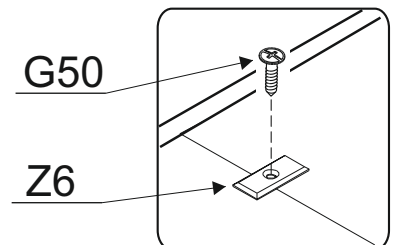
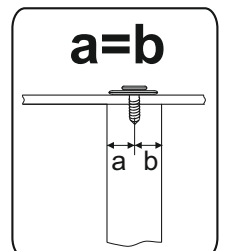
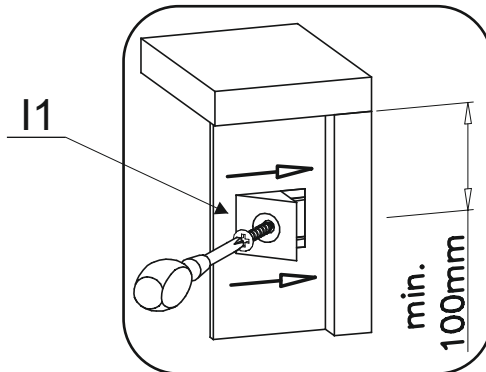
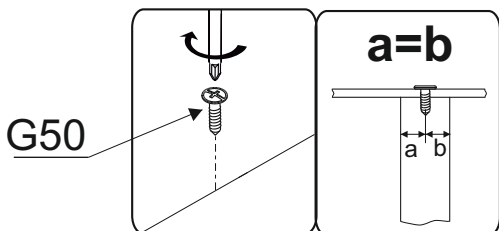
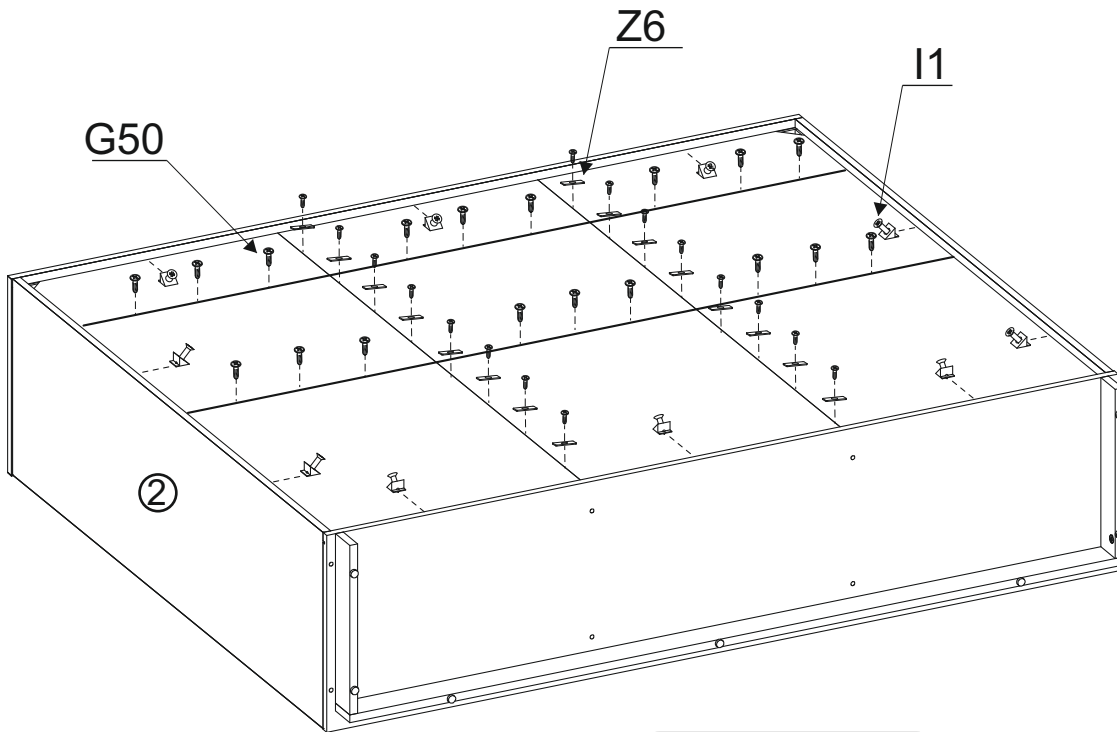
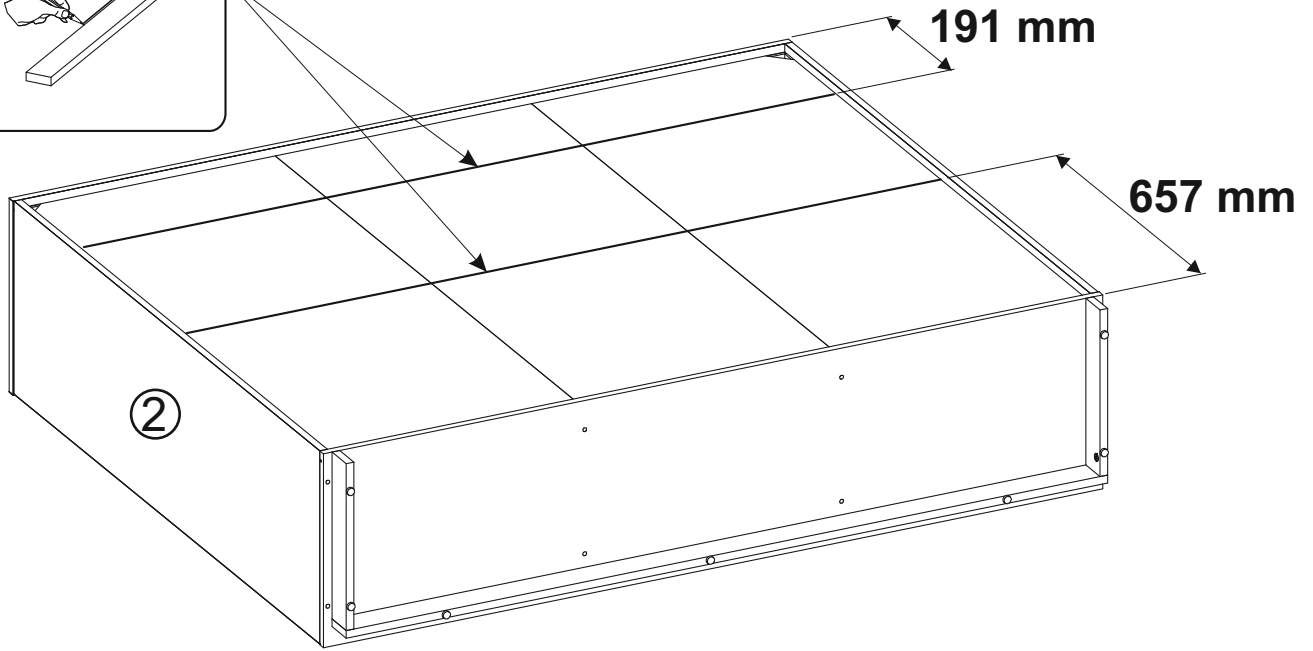
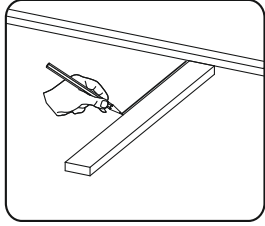



XXI

G34



3,5x16

x2

M11

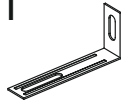

x2

G46



6,3x9,5

x2

3019175 I8



x33

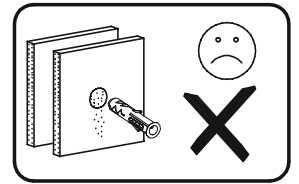
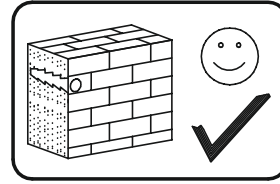
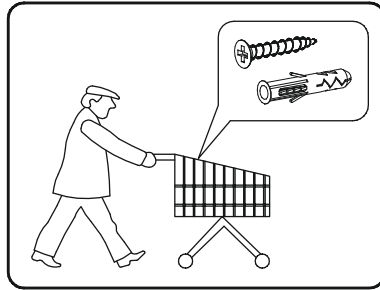

M11

M11

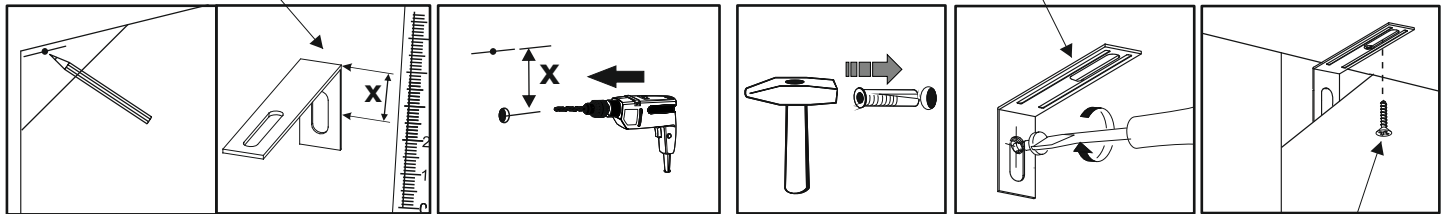

G34

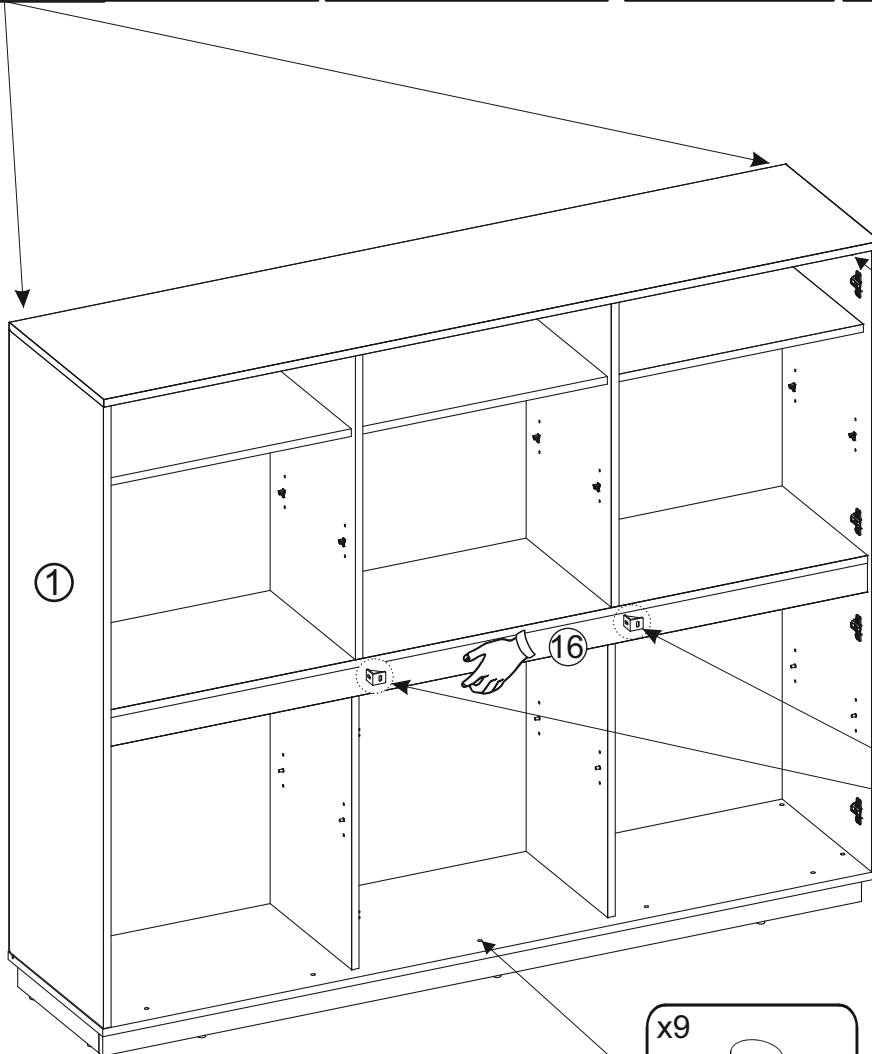

I8

x24

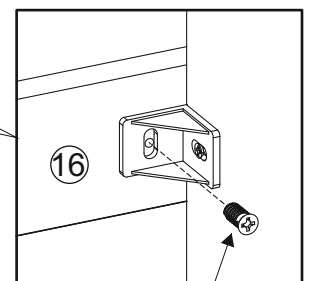
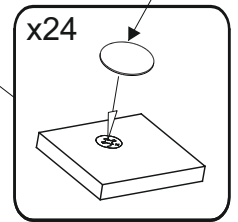

G46

x9

I8

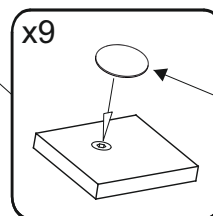

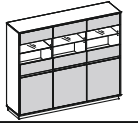

XXII

F20



x12

G49



4x16

x12

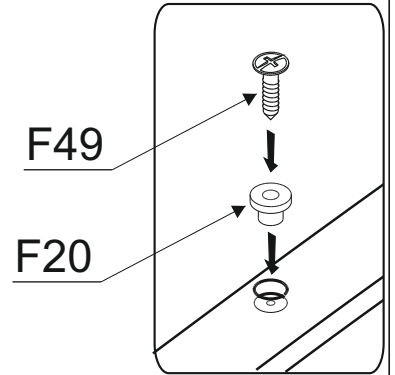
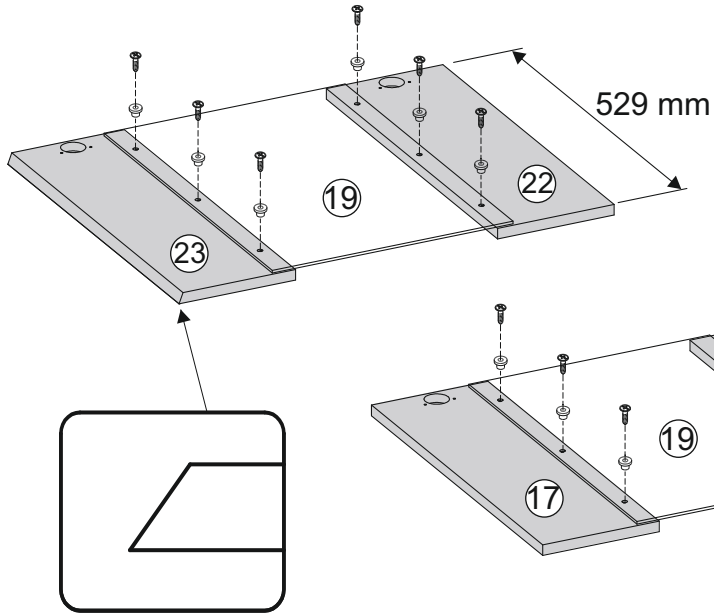

XXIII

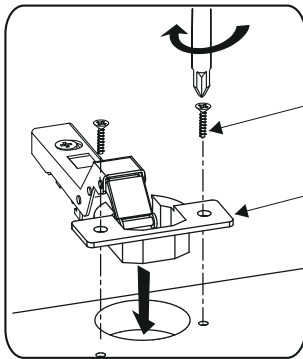

G34

C10

C10

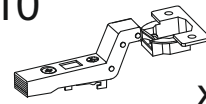

x8

G34



3,5x16

x16

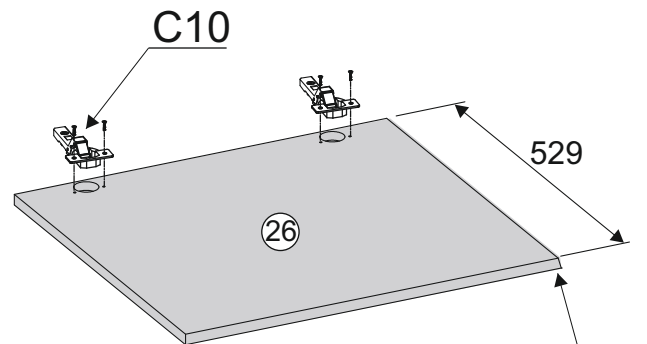
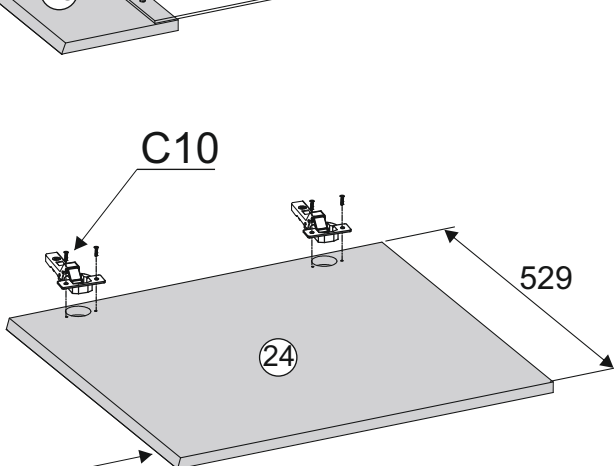
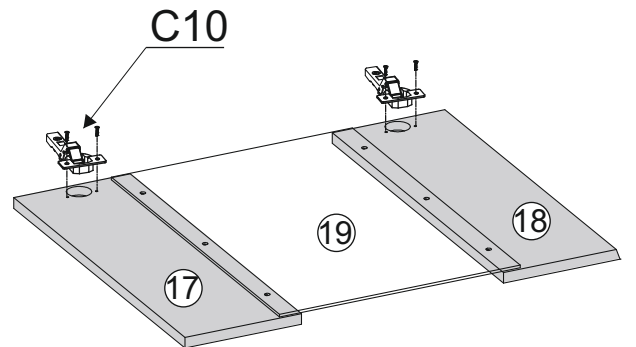
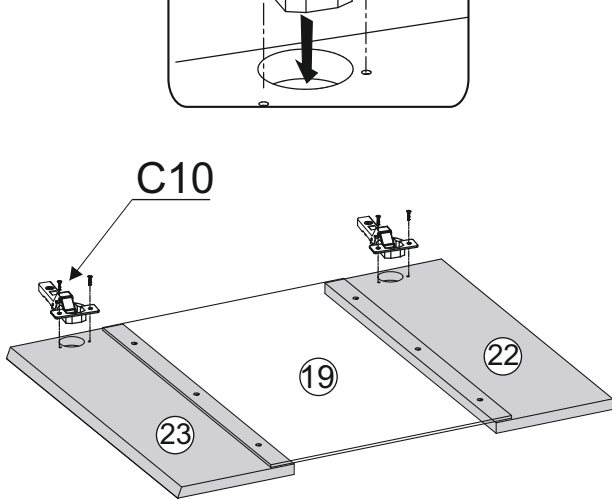

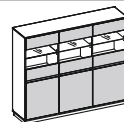

XXIV

F20



x6

G49



4x16

x6

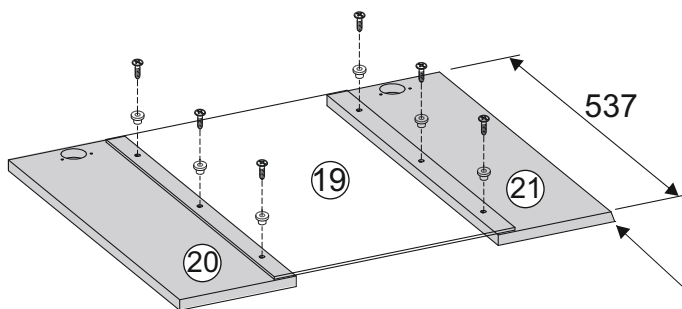

F49

F20

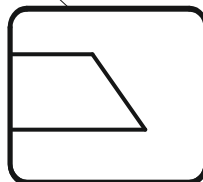
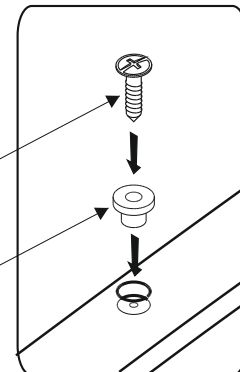

XXV

C9

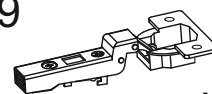

x4

G34



3,5x16

x8

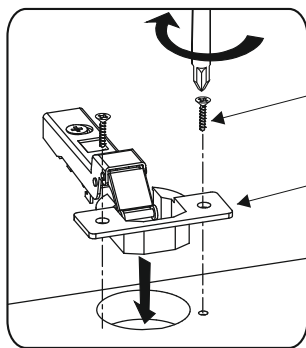

G34

C9

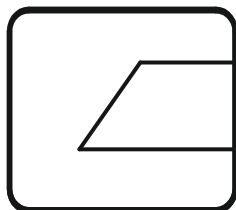
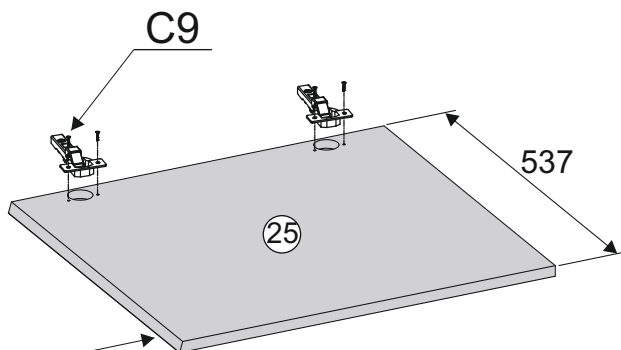
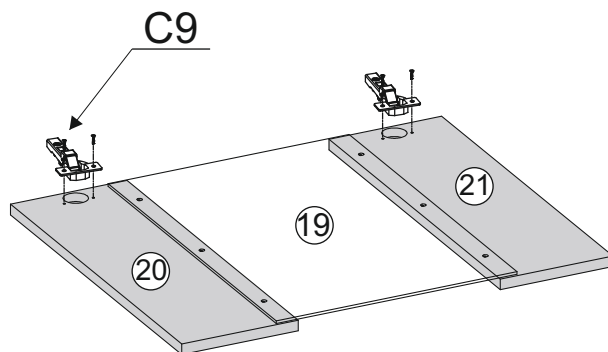

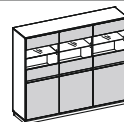

XXVI

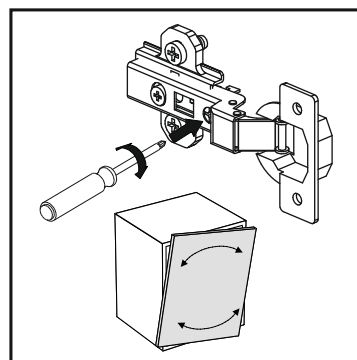
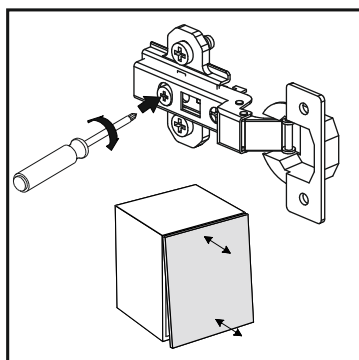
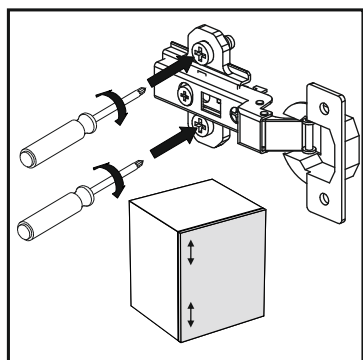
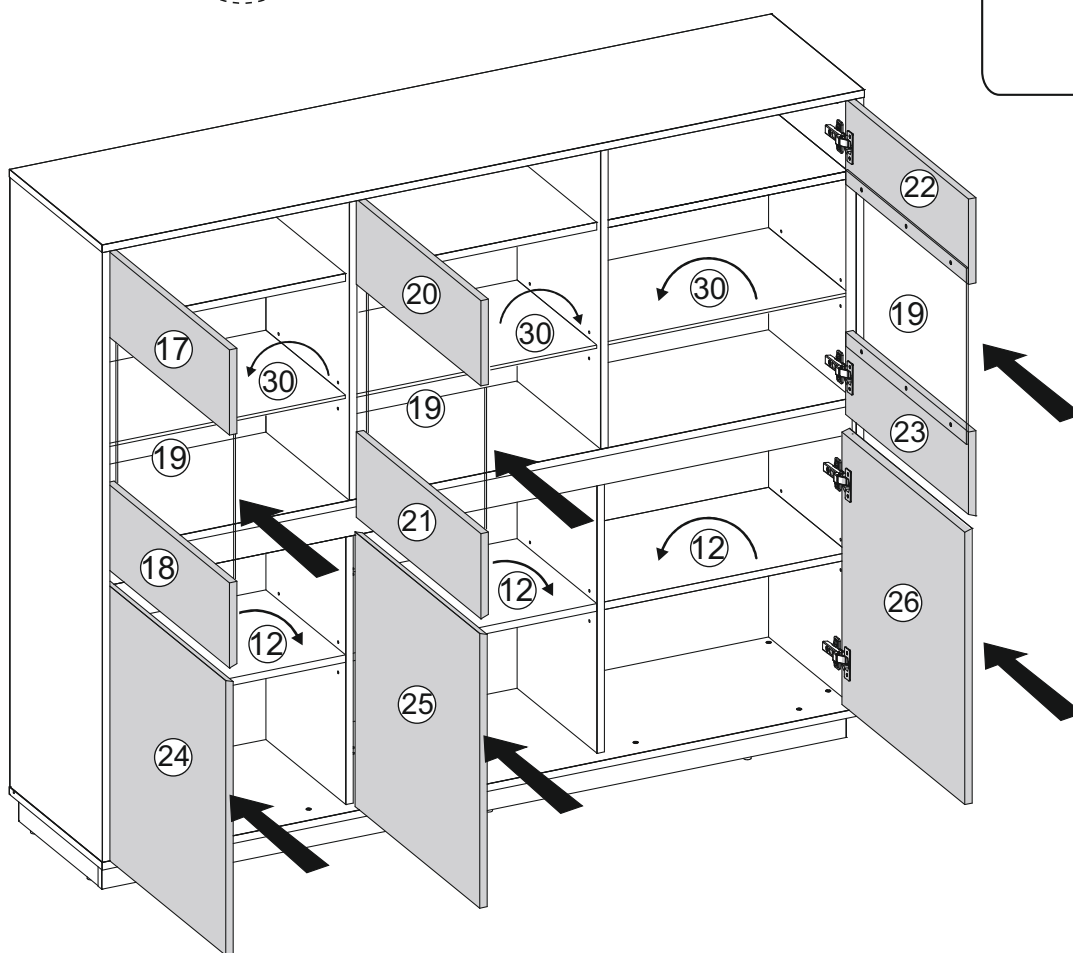
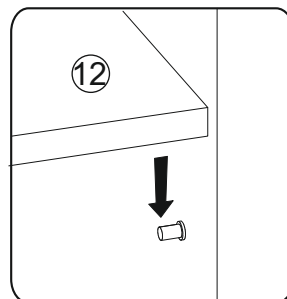
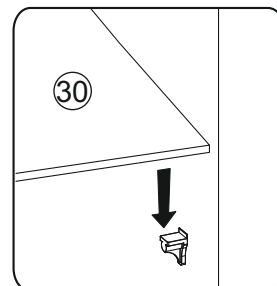
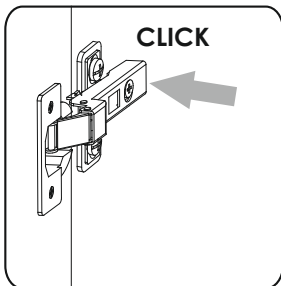
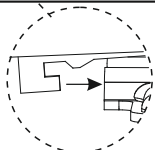
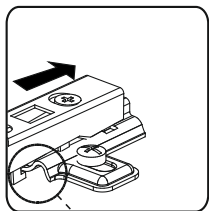
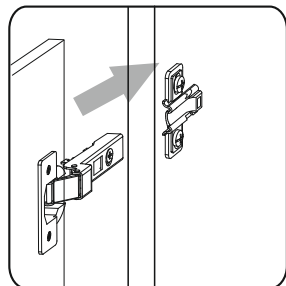

Name • Nom • Nome • Naam • Nazwa • Imięno
• Názov • Név • Denumire • Isim • Имя

Nr • No • N° • Номер • Č • Sz

Typ • Type • Tip • Típus • Tipo • Tun

SONORA

— —

56

D

Unser Direktservice für Beschlagteile

Sollte Ihnen ein Beschlagteil fehlen, können Sie diese Servicekarte direkt an die untenstehende Adresse mailen. Wir können allerdings nur Beschlagteile auf diesem Wege verschicken. Sollten Sie eine andere Beanstandung an Ihrem Möbelstück haben, so wenden sie sich bitte direkt an Ihr Möbelhaus.

Our direct order service for fitting

If a fitting part is missing, you can e-mail this service card directly to the address below. However, we can only send fitting parts in this way. If you have any other cause for complaint concerning your item of furniture, please contact your furniture store directly.

Naše přímé služby pro kování

Chybí-li vám nějaký díl z kování, můžete tuto servisní kartu odeslat e-mailem přímo na níže uvedenou adresu. Touto cestou však můžeme zosílat jen díly kování. Pokud byste reklamovali jiný díl nábytku, obraťte se přímo na svého prodejce nábytku.

Bien etudier la notice de montage

S'il vous manque une ferrure, veuillez envoyer directement la présente carte service à l'adresse e-mail indiquée ci-dessous. Cependant, ceci nous permet uniquement d'envoyer des ferrures. Pour tout autre type de réclamation concernant votre meuble, veuillez contacter directement votre magasin d'ameublement.

Il nostro servizio diretto per l'ordine della ferramenta

Qualora Vi dovesse mancare un pezzo di fissaggio, allora Vi preghiamo di inviare questa carta di servizio immediatamente all'indirizzo sottostante. Possiamo inviare i pezzi di fissaggio solamente per mezzo di questo procedimento. Qualora dovete avere qualche altra reclamazione in merito al mobile, allora Vi preghiamo di rivolgerVi direttamente al Vostro Negozio di mobili.

Нашата директна услуга за обков

Ако липсват части от комплекта, попълнете настоящата сервисна карта и ни я изпратете на e-mail адреса, посочен по-долу. По този начин можем да доставяме само липсващи елементи от обкова. Ако установите други дефекти по мебелите, Ви съветваме да се обърнете към мебелната къща/магазин, от който сте закупили стоката.

Onze directservice voor losse onderdelen

Wanneer er een onderdeel ontbreekt, kunt u deze servicekaart direct aan onderstaand e-mailadres sturen. Wij kunnen langs deze weg echter alleen beslagdelen versturen. Mocht u een ander probleem aan uw meubel hebben, verzoeken wij u contact op te nemen met uw meubeldealer.

Nasz bezpośredni serwis części montazowych

Jeżeli brakuje części koniecznych do montażu, prosimy o przesłanie nam niniejszej karty serwisowej na niżej podany adres e-mailowy. W ten sposób możemy przesłać Państwu tylko brakujące części. W przypadku innych reklamacji dotyczących mebla, prosimy zgłosić się do salonu meblowego, w którym został dokonany zakup.

Servis za okove

U slučaju da nedostaju neki od dijelova molimo vas da na dolje navedenu mail adresu pošaljete ovaj servisni obrazac. Na ovaj način mogu se dostaviti samo okovi. U slučaju da imate dodatne prigovore vezane uz komad namještaja molimo vas da se obratite izravno trgovini namještaja gdje je isti kupljen.

Direktszolgálatunk vasalatok esetén

Ha hiányzik egy vasalat, ezt a kártyát közvetlenül elküldheti az alább található címre. Azonban csakis vasalatókat tudunk így küldeni. Amennyiben másfajta reklamáció áll fenn bútorárbaját illetően, forduljon közvetlenül a bútoráruházhoz.

Náš priamy servis pre časti kovania

Ak by Vám chýbala nejaká časť kovania, môžete poslať túto servisnú kartu poslať e-mailom na nižšie uvedenú adresu. Diely kovania vieme poslať iba týmto spôsobom. Ak by ste mali inú reklamáciu ohľadom Vášho nábytku, obraťte sa priamo na Vašu predajňu nábytku.

Naše direktne služne stornitve za okovje

Ce vam manjka kakšno okovje, lahko to servisno kartico pošljete po e-pošti direktno na spodnji naslov. Po tej poti vam lahko pošljemo samo okovje. Če želite reklamirati kakšen drug del pohištva, se obrnite neposredno na vašo trgovino pohištva.

Service-ul nostru direct pentru feronerie

În cazul în care vă lipsește o piesă de feronerie puteți să trimiteți direct acest card de service prin e-mail la adresa de mai jos. Noi nu putem expedia piese de feronerie decât pe această cale. Dacă aveți o altă reclamație referitoare la piesa de mobilier, atunci vă rugăm să vă adresați direct la magazinul dvs. de mobilă.

Наш прямой сервис для поставок фурнитуры

Если окажется, что Вам не хватает того или иного элемента фурнитуры, Вы можете отправить сервисную карту по факсу непосредственно на нижеприведенный адрес электронной почты. Однако, таким образом мы можем пересылать лишь фурнитуру. Если же у Вас возникнут иные претензии относительно приобретенной мебели, пожалуйста, обращайтесь непосредственно в организацию, осуществившую продажу.

Vår direktservice för beslagsdelar

Om du saknar en beslagsdel kan du skicka detta servicekort direkt till e-postadressen som anges nedan. Tänk på att detta är den enda möjligheten att skicka beslagsdelar till dig. Om du vill reklamera din möbel av en annan anledning måste du kontakta ditt möbelhus direkt.









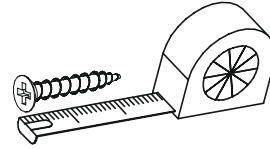

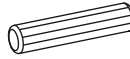
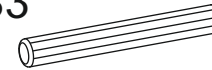

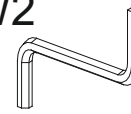

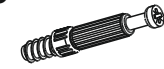

Nuestro servicio directo para accesorios

Si le falta algún accesorio, puede enviar esta tarjeta de servicio directamente a la siguiente dirección. No obstante, por este método solo podemos enviar accesorios. Si tiene alguna otra objeción sobre su mueble, consulte directamente con su mueblería.

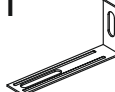
Donatilar için doğrudan servisimiz

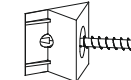
Bir donatınız eksikse bu servis kartını doğrudan aşağıda bulunan adrese doğrudan mail yazabilirsiniz. Sadece bu yölla donatıları gönderilebilir. Mobilyanızda başka şikayetleriniz varsa lütfen doğrudan mobilya satıcınıza danışın.

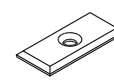
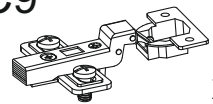
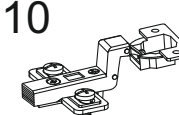

B1  ø8x35 X...	B3  ø8x60 X...	A1  ø7x50 X...
W2  X...	K1  15x12 X...	K10  X...
G34  3,5x16 X...	G48  6,3x13 X...	G49  4x16 X...
G50  3x20 X...	I7  X...	F13  X...
M11  X...	F2  X...	I1  X...
F20  X...	Z6  X...	C9  X...
C10  X...	P4  X...	F4  X...

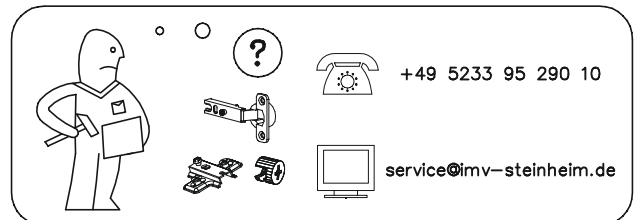
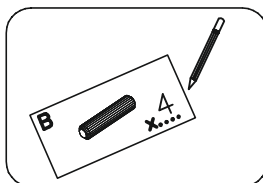

+49 5233 95 290 10

service@mv-steinheim.de

Name • Nom • Nome • Naam • Nazwa • Jméno
• Názov • Név • Denumire • Isim • Имя

Nr • No • N° • Номер • Č • Sz

Typ • Type • Tip • Típus • Tipo • Tun

SONORA

56

D

Unser Direktservice für Beschlagteile

Sollte Ihnen ein Beschlagteil fehlen, können Sie diese Servicekarte direkt an die untenstehende Adresse mailen. Wir können allerdings nur Beschlagteile auf diesem Wege verschicken. Sollten Sie eine andere Beanstandung an Ihrem Möbelstück haben, so wenden sie sich bitte direkt an Ihr Möbelhaus.

Our direct order service for fitting

If a fitting part is missing, you can e-mail this service card directly to the address below. However, we can only send fitting parts in this way. If you have any other cause for complaint concerning your item of furniture, please contact your furniture store directly.

GB

Naše přímé služby pro kování

Chybí-li vám nějaký díl z kování, můžete tuto servisní kartu odeslat e-mailem přímo na níže uvedenou adresu. Touto cestou však můžeme zoslat jen díly kování. Pokud byste reklamovali jiný díl nábytku, obraťte se přímo na svého prodejce nábytku.

CZ

Bien etudier la notice de montage

S'il vous manque une ferrure, veuillez envoyer directement la présente carte service à l'adresse e-mail indiquée ci-dessous. Cependant, ceci nous permet uniquement d'envoyer des ferrures. Pour tout autre type de réclamation concernant votre meuble, veuillez contacter directement votre magasin d'ameublement.

F

Il nostro servizio diretto per l'ordine della ferramenta

Qualora Vi dovesse mancare un pezzo di fissaggio, allora Vi preghiamo di inviare questa carta di servizio immediatamente all'indirizzo sottostante. Possiamo inviare i pezzi di fissaggio solamente per mezzo di questo procedimento. Qualora dovete avere qualche altra reclamazione in merito al mobile, allora Vi preghiamo di rivolgerVi direttamente al Vostro Negozio di mobili.

I

Нашата директна услуга за обков

Ако липсват части от комплекта, попълнете настоящата сервисна карта и ни я изпратете на e-mail адреса, посочен по-долу. По този начин можем да доставяме само липсващи елементи от обкова. Ако установите други дефекти по мебелите, Ви съветваме да се обърнете към мебелната къща/магазин, от който сте закупили стоката.

BG

Onze directservice voor losse onderdelen

Wanneer er een onderdeel ontbreekt, kunt u deze servicekaart direct aan onderstaand e-mailadres sturen. Wij kunnen langs deze weg echter alleen beslagdelen versturen. Mocht u een ander probleem aan uw meubel hebben, verzoeken wij u contact op te nemen met uw meubeldealer.

NL

Nasz bezpośredni serwis części montażowych

Jeżeli brakuje części koniecznych do montażu, prosimy o przesłanie nam niniejszej karty serwisowej na niżej podany adres e-mailowy. W ten sposób możemy przesłać Państwu tylko brakujące części. W przypadku innych reklamacji dotyczących mebla, prosimy zgłosić się do salonu meblowego, w którym został dokonany zakup.

PL

Servis za okove

U slučaju da nedostaje neki od dijelova molimo vas da na dolje navedenu mail adresu pošaljete ovaj servisni obrazac. Na ovaj način mogu se dostaviti samo okovi. U slučaju da imate dodatne prigovore vezane uz komad namještaja molimo vas da se obratite izravno trgovini namještaja gdje je isti kupljen.

HR

Direktszolgáltatunk vasalattok esetén

Ha hiányzik egy vasalat, ezt a kártyát közvetlenül elküldheti az alább található címre. Azonban csakis vasalattokat tudunk így küldeni. Amennyiben másfajta reklamáció áll fenn bútordarabját illetően, forduljon közvetlenül a bútortárházhoz.

HU

Náš priamy servis pre časti kovania

Ak by Vám chýbala nejaká časť kovania, môžete poslať túto servisnú kartu poslať e-mailom na nižšie uvedenú adresu. Diely kovania vieme poslať iba týmto spôsobom. Ak by ste mali inú reklamáciu ohľadom Vášho nábytku, obráťte sa priamo na Vašu predajňu nábytku.

SK

Naše direktne uslužne storitve za okovje

Če vam manjka kakšno okovje, lahko to servisno kartico pošljete po e-pošti direktno na spodnji naslov. Po tej poti vam lahko pošljemo samo okovje. Če želite reklamirati kakšen drug del pohištva, se obrnite neposredno na vašo trgovino pohištva.

SLO

Service-ul nostru direct pentru feronerie

În cazul în care vă lipsește o piesă de feronerie puteți să trimiteți direct acest card de service prin e-mail la adresa de mai jos. Noi nu putem expedia piese de feronerie decât pe această cale. Dacă aveți o altă reclamație referitoare la piesa de mobilier, atunci vă rugăm să vă adresați direct la magazinul dvs. de mobilă.

RO

Наш прямой сервис для поставок фурнитуры

Если окажется, что Вам не хватает того или иного элемента фурнитуры, Вы можете отправить сервисную карту по факсу непосредственно на нижеприведенный адрес электронной почты. Однако, таким образом мы можем пересылать лишь фурнитуру. Если же у Вас возникнут иные претензии относительно приобретенной мебели, пожалуйста, обращайтесь непосредственно в организацию, осуществившую продажу.

RUS

Vår direktservice för beslagsdelar

Om du saknar en beslagsdel kan du skicka detta servicekort direkt till e-postadressen som anges nedan. Tänk på att detta är den enda möjligheten att skicka beslagsdelar till dig. Om du vill reklamera din möbel av en annan anledning måste du kontakta ditt möbelhus direkt.

S

Nuestro servicio directo para accesorios

Si le falta algún accesorio, puede enviar esta tarjeta de servicio directamente a la siguiente dirección. No obstante, por este método solo podemos enviar accesorios. Si tiene alguna otra objeción sobre su mueble, consulte directamente con su mueblería.

ES

Donatilar için doğrudan servisimiz

Bir donatınız eksikse bu servis kartını doğrudan aşağıda bulunan adrese doğrudan mail yazabilirsiniz. Sadece bu yölla donatıları gönderilebilir. Mobilyanızda başka şikayetleriniz varsa lütfen doğrudan mobilya satıcınıza danışın.

TR

nr	L[mm]	B[mm]	T[mm]	Menge	Colli
1	1288	399	16	1	1/3
2	1288	399	16	1	1/3
3	639	360	16	1	1/3
4	639	360	16	1	1/3
5	633	344	16	1	1/3
6	633	344	16	1	1/3
7	1641	400	16	1	2/3
8	1607	361	16	1	2/3
9	1641	400	16	1	2/3
10	525	343	16	2	2/3
11	525	343	16	1	2/3
12	525	343	16	3	1/3
13	1603	60	16	1	2/3
14	344	60	16	1	1/3

nr	L[mm]	B[mm]	T[mm]	Menge	Colli
15	344	60	16	1	1/3
16	1607	60	16	1	2/3
17	529	180	16	1	3/3
18	529	180	16	1	3/3
19	519	372	4	3	3/3
20	537	180	16	1	3/3
21	537	180	16	1	3/3
22	529	180	16	1	3/3
23	529	180	16	1	3/3
24	580	529	16	1	3/3
25	580	537	16	1	3/3
26	580	529	16	1	3/3
27	1298	539	3	1	2/3
28	1298	539	3	1	2/3
29	1298	239	3	1	2/3
30	524	337	5	3	3/3

