

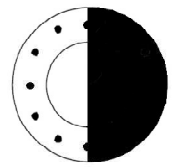

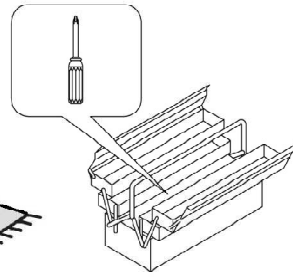

HERMAN

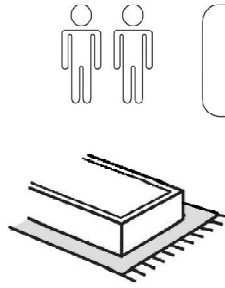
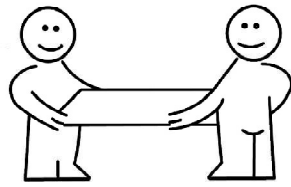
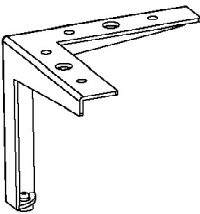
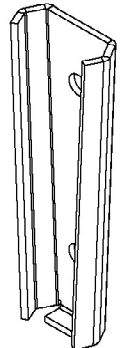
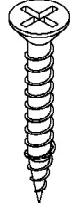

60 min

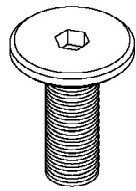
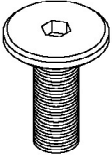
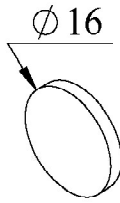
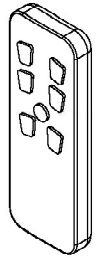
		 <p>4x30</p>	 <p>6,4x40</p>	 <p>M8x16</p>
<p>Ax8</p>	<p>Bx4</p>	<p>Cx32</p>	<p>Dx8</p>	<p>Ex8</p>
 <p>M6x16</p>	 <p>Ø16</p>			
<p>Fx16</p>	<p>Gx10</p>	<p>Hx2</p>	<p>Ix1</p>	<p>Jx1</p>

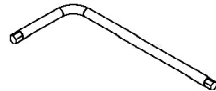
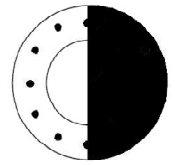
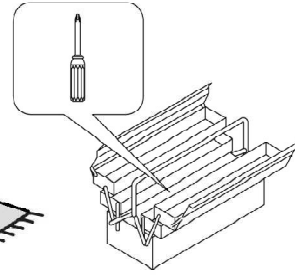
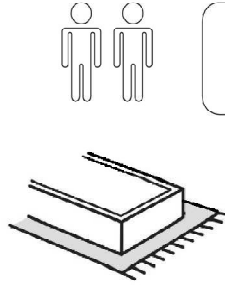
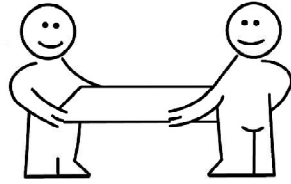

60 min

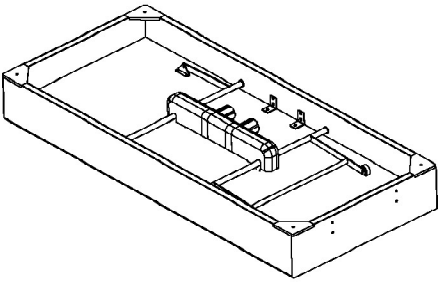
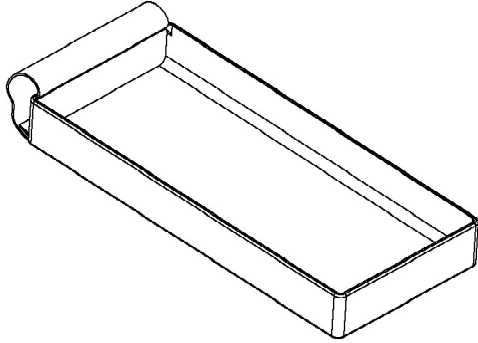
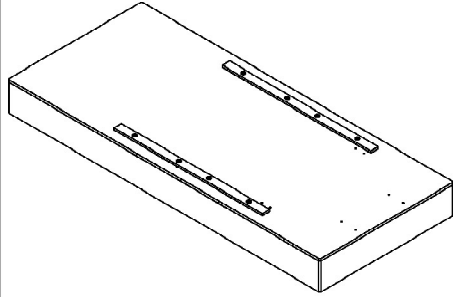
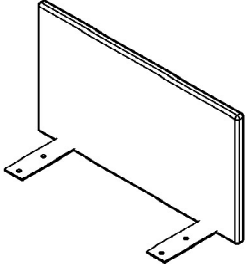
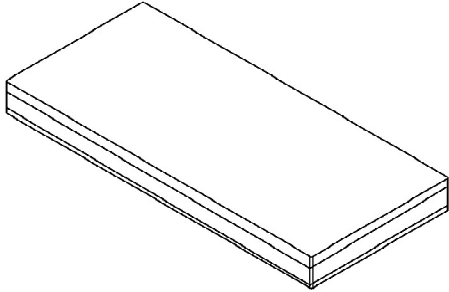
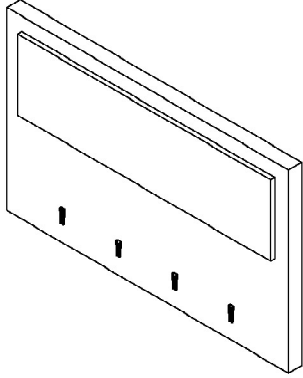
		
1x2(C1, C2)	2x2 (C1, C2)	3x2(C3, C4)
		
4x2(C3, C4)	5x2(C5, C6)	6x1(C7)

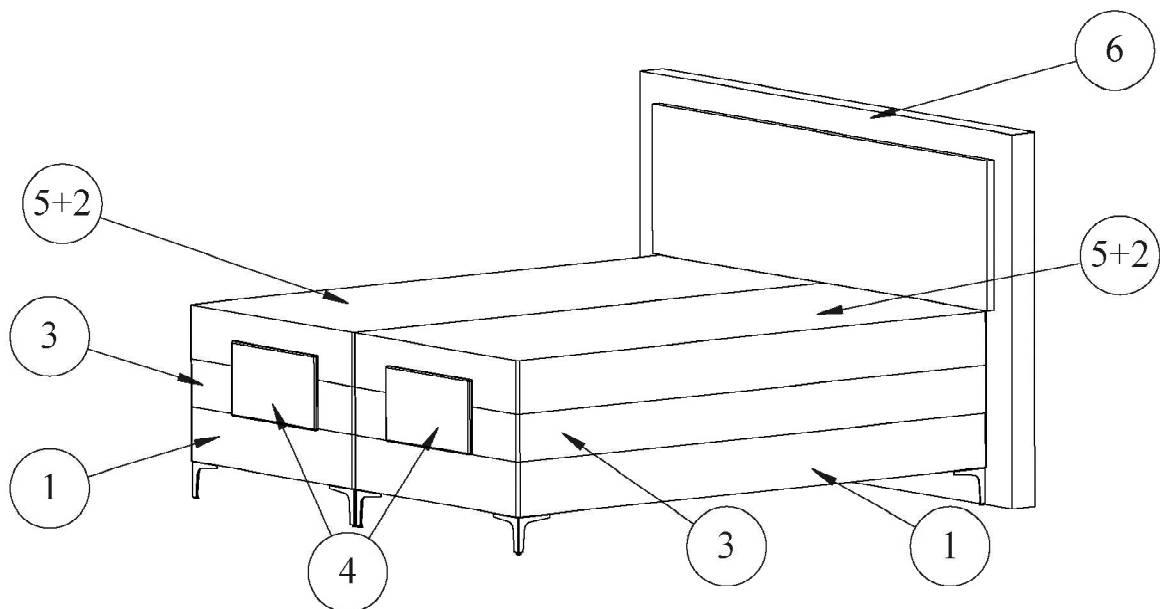

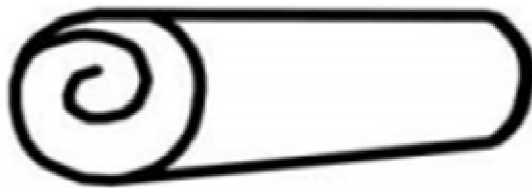
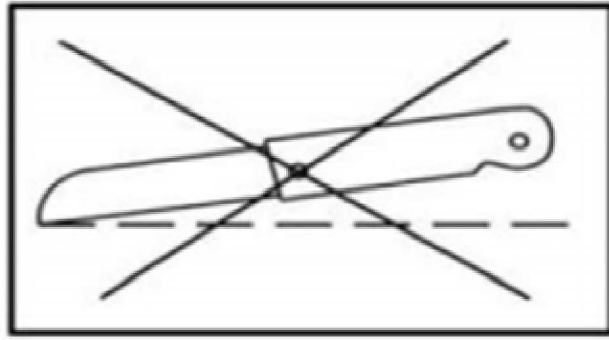

195 cm



72h

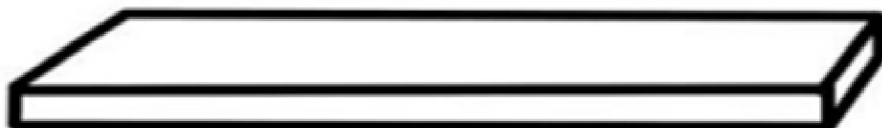



1x1

x2

3

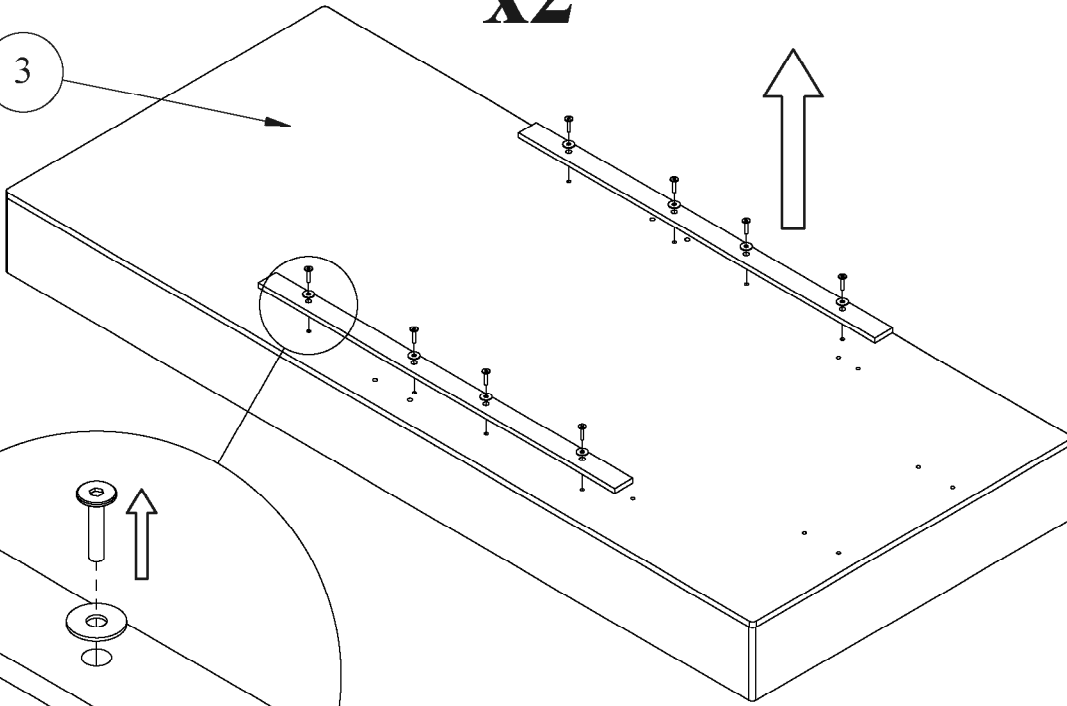

x8

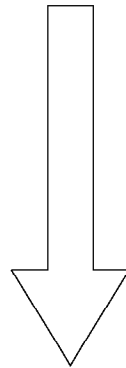
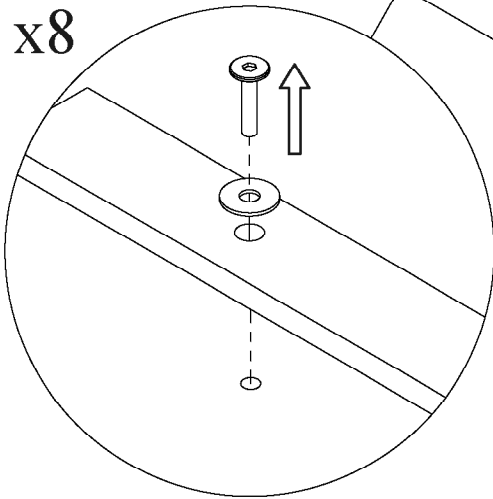

x2

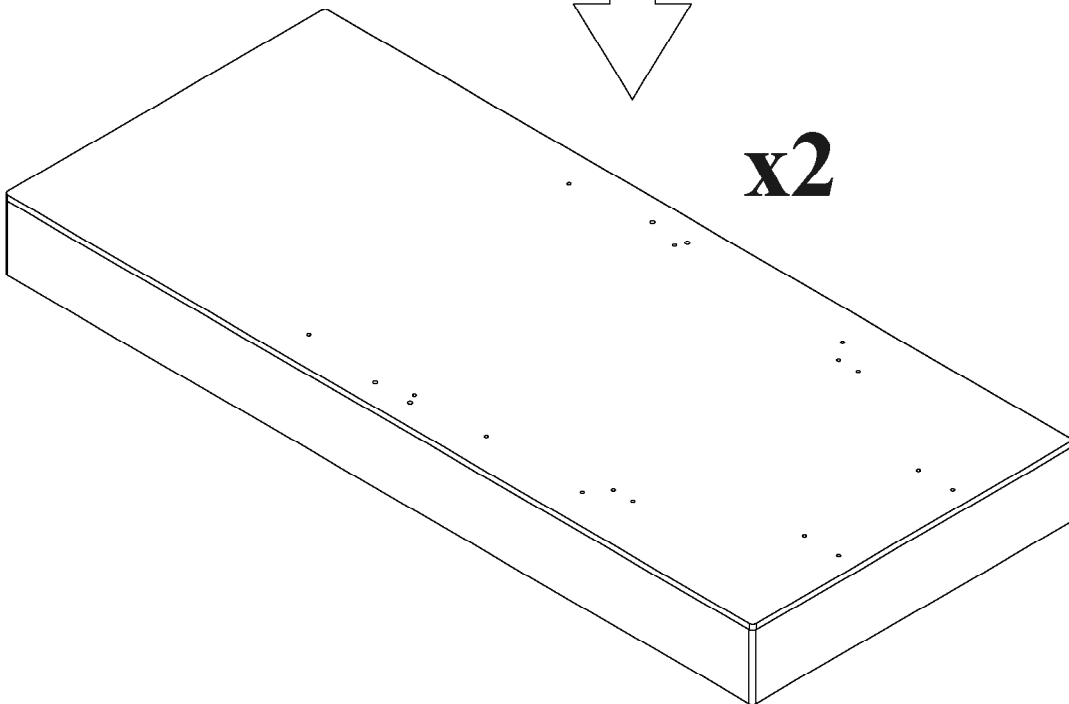

AUFBAUANLEITUNG XXXL-D

02/2021

LIEF:1408

b/13



Fx8

M6x16

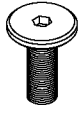

Ex8

M8x16



Bx4



6,4x40

Dx8

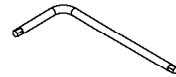

Jx1



Ix1

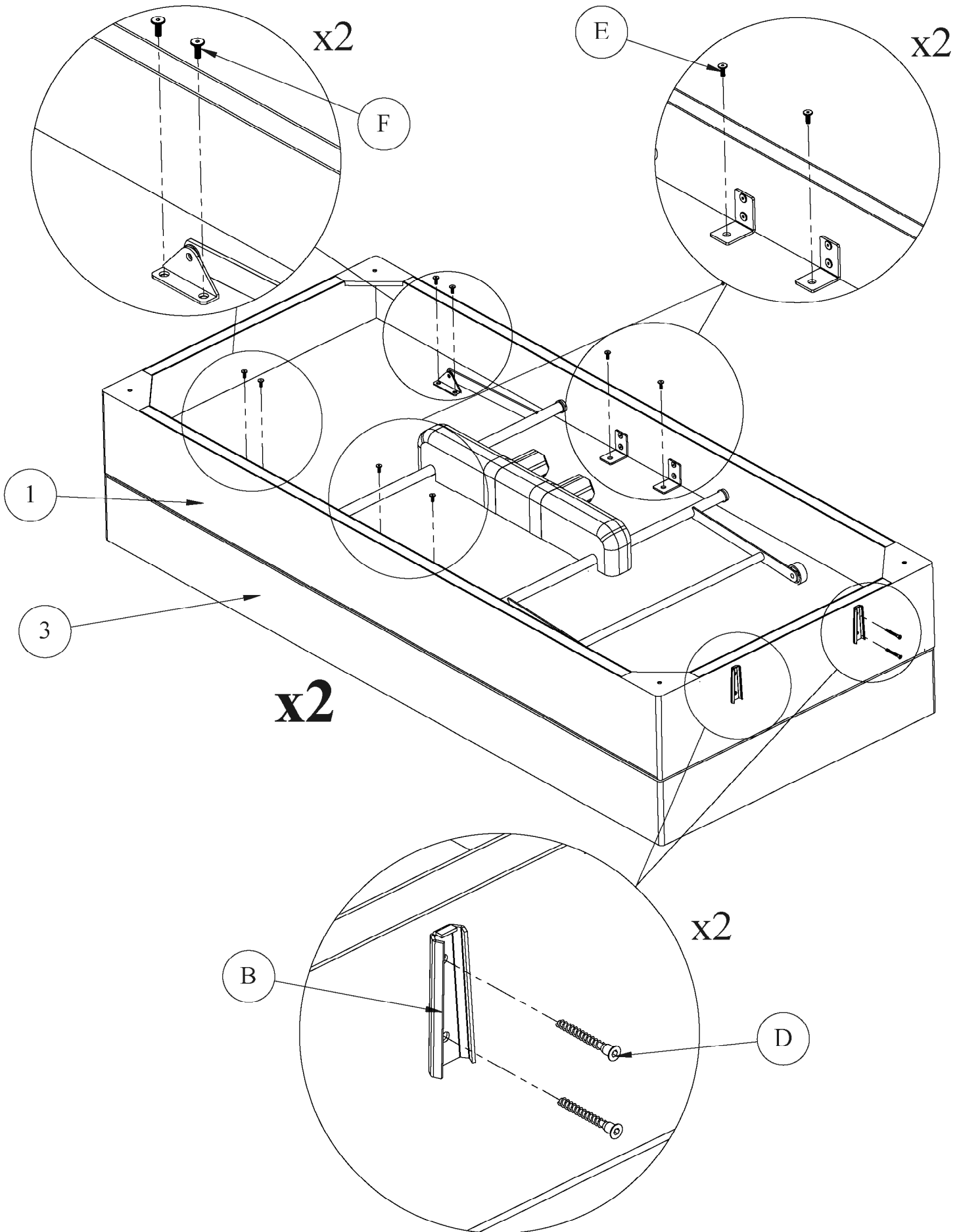

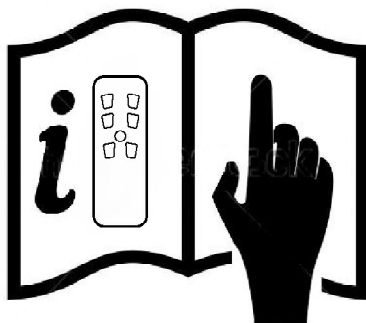
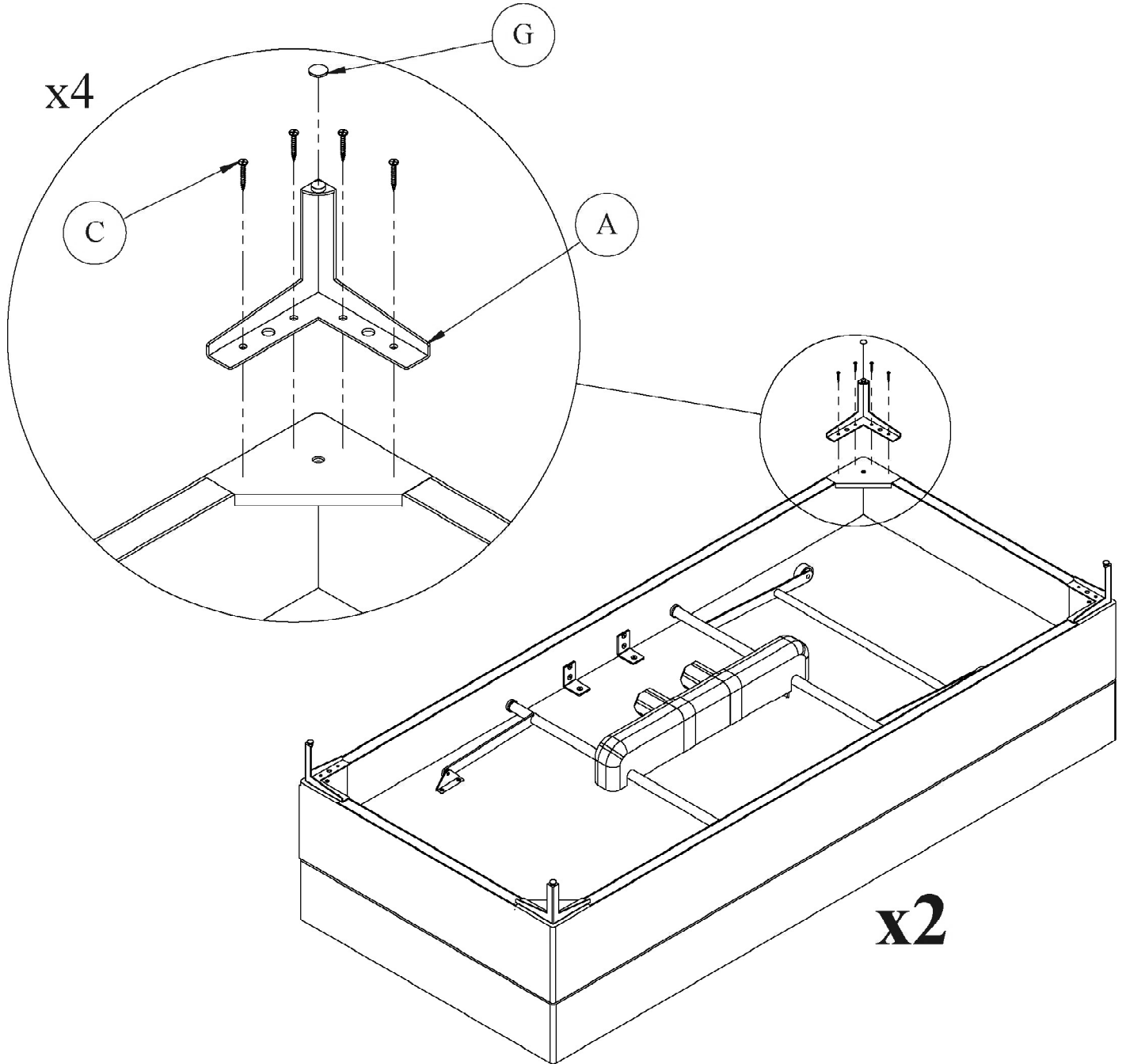
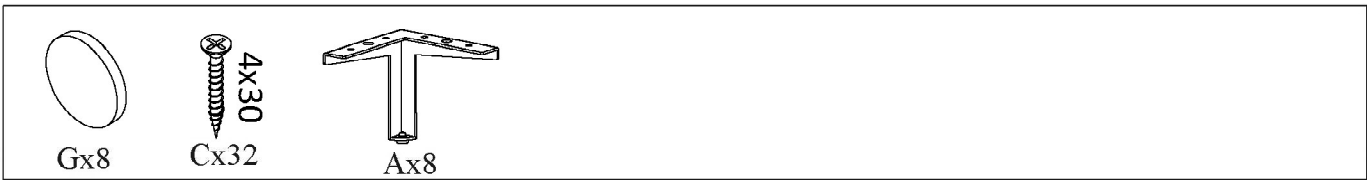

SEE PAGE 12-13

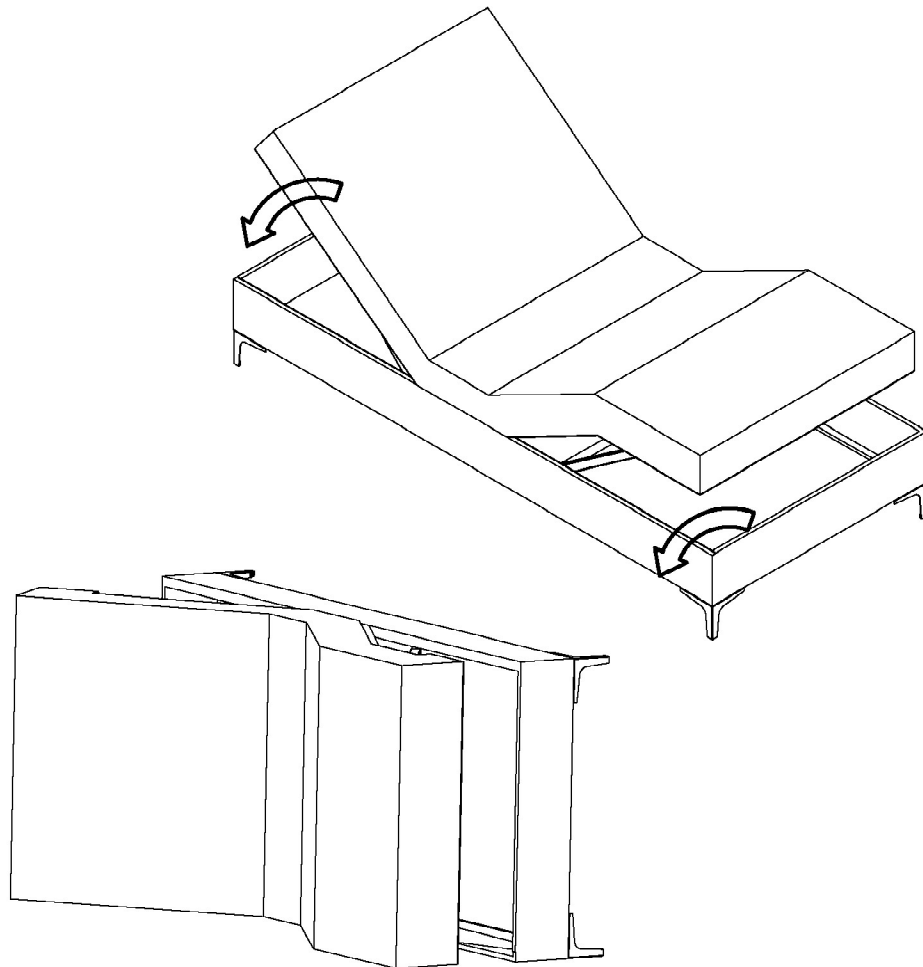
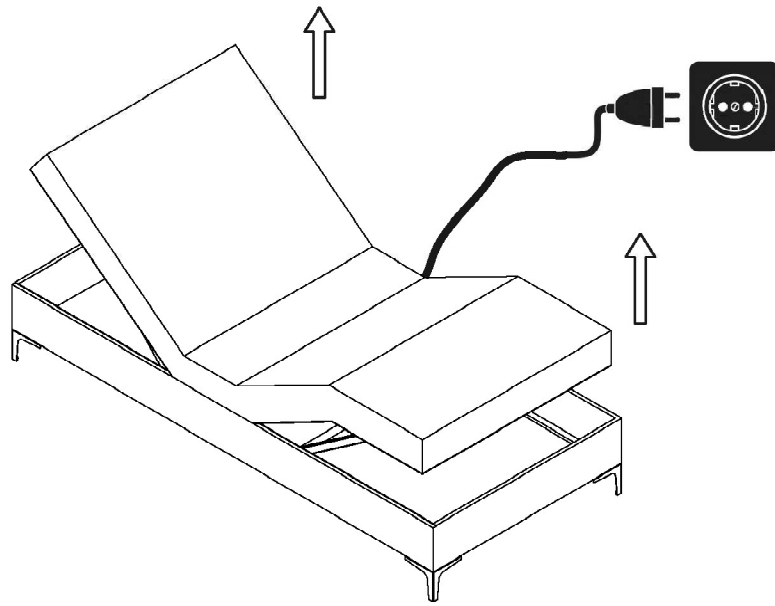

Fx8



Jx1

x2

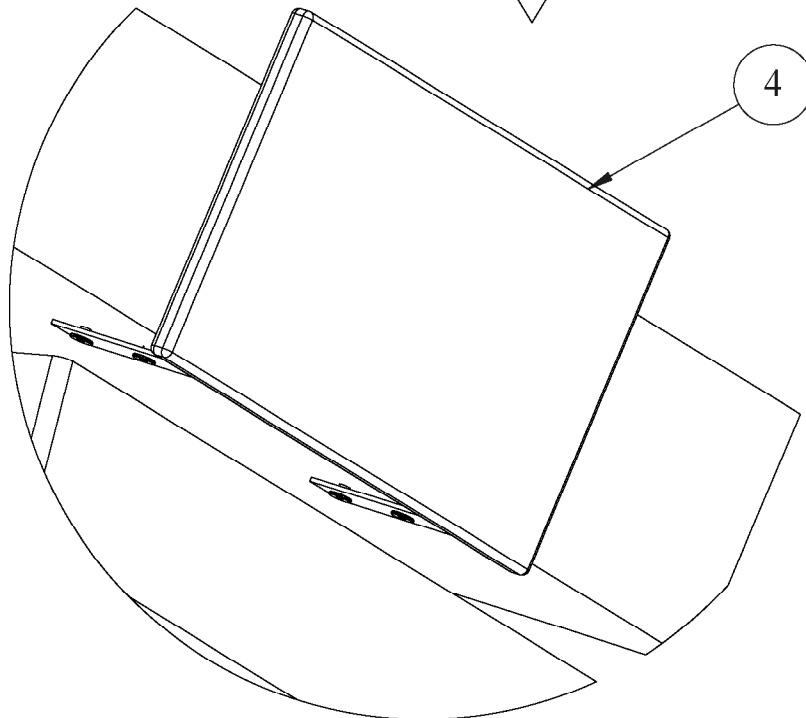
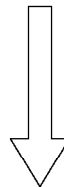
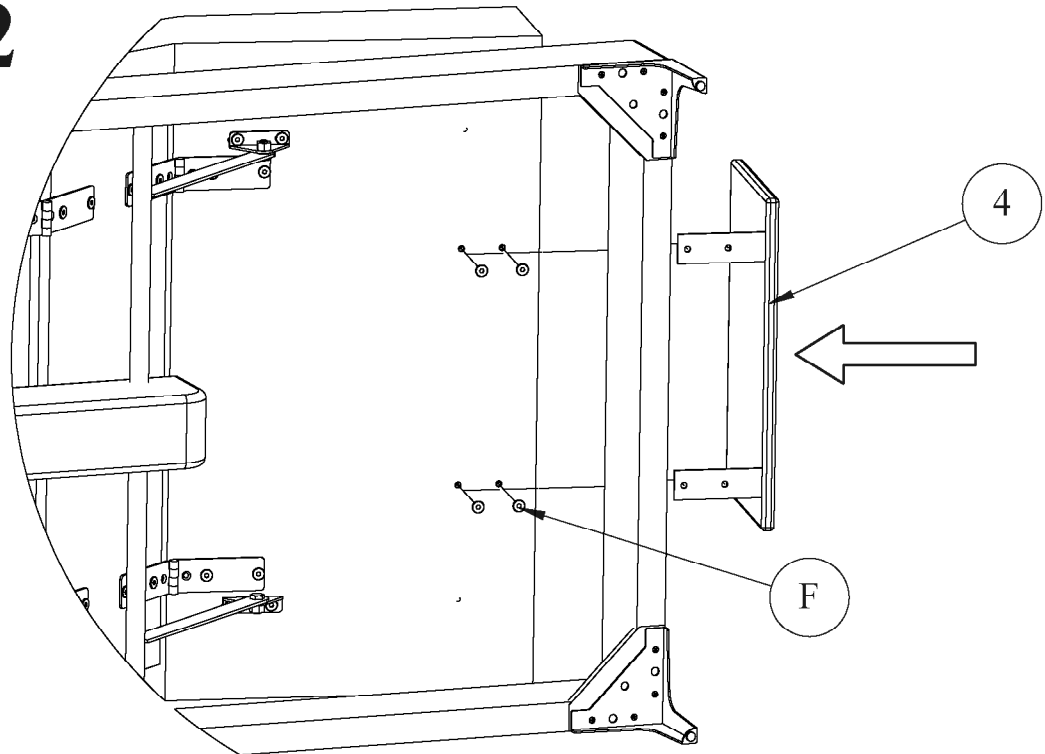

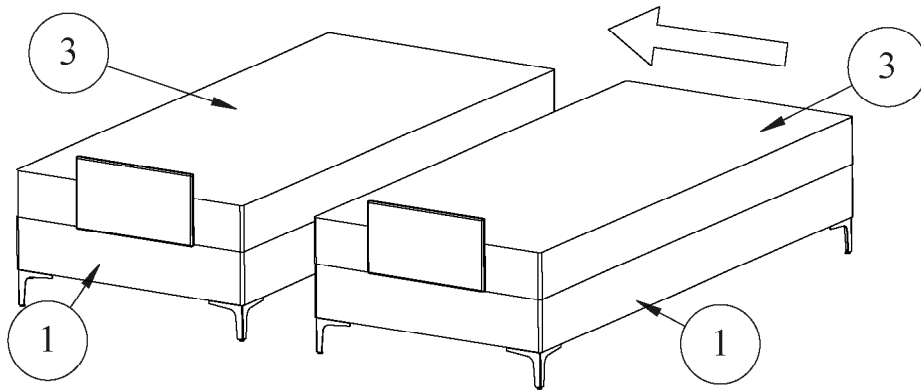

Gx2

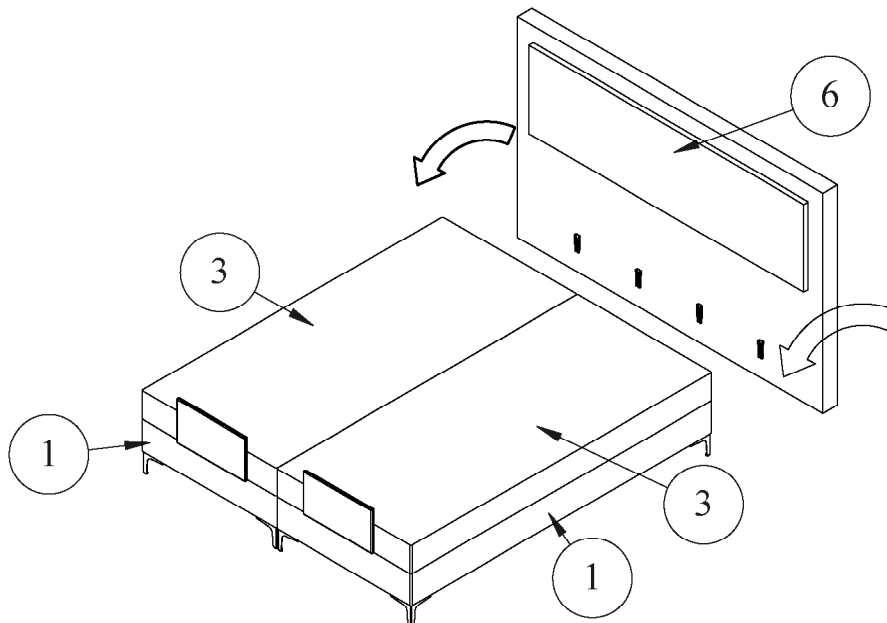
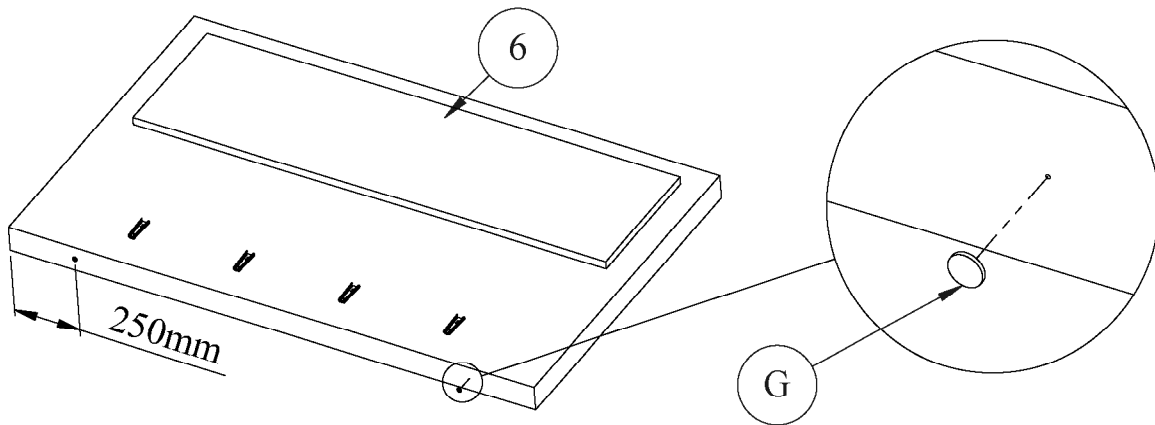

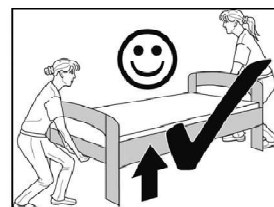
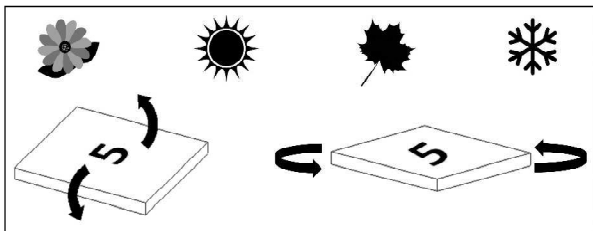
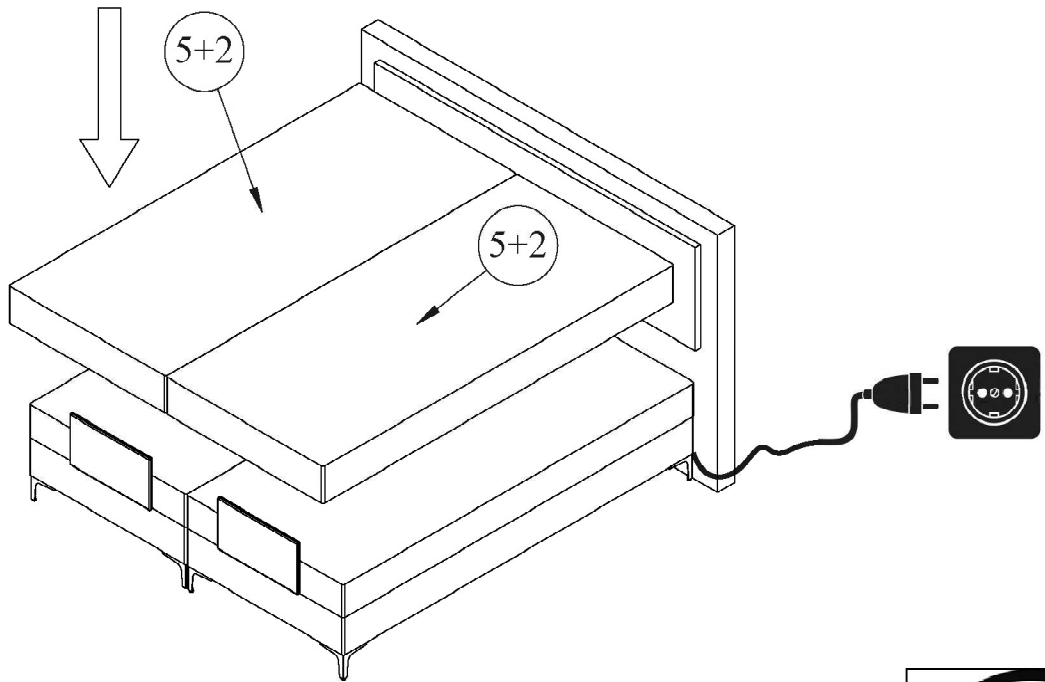
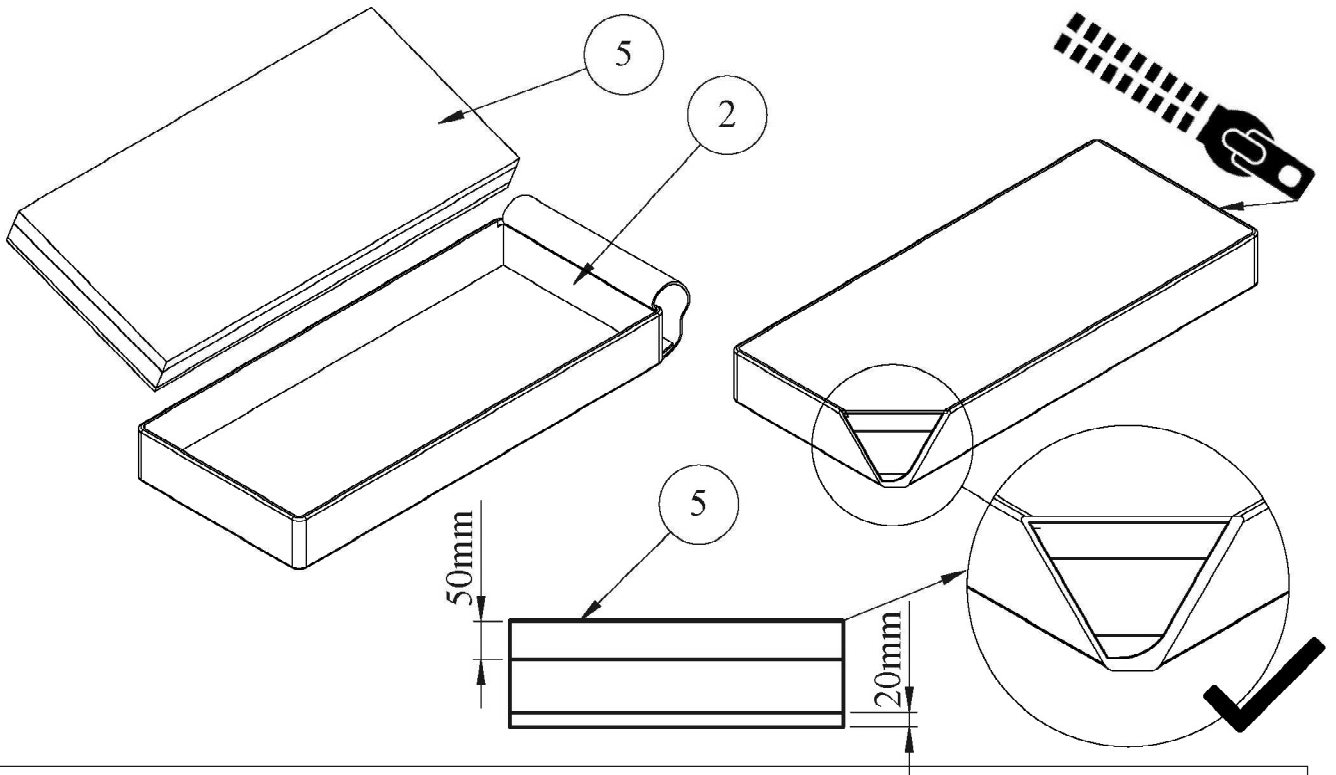

Instruction manual (EN)

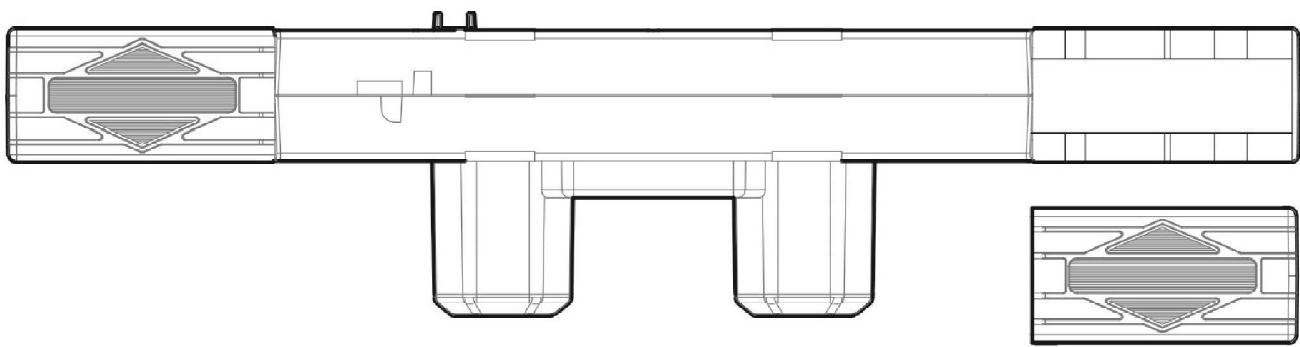

Safety instructions:

- Please read these instructions carefully.
- During adjustments - due to the contact points between mobile and fixed components - Keep children and pets away from the motor.
- This appliance can be used by children aged from 8 years and above and persons with reduced physical, sensory or mental capabilities or lack of experience and knowledge if they have been given supervision or instruction concerning use of the appliance in a safe way and understand the hazards involved. Children shall not play with the appliance. Cleaning and user maintenance shall not be made by children without supervision.
- The engine can only be used in dry locations.
- It is not permitted to use the engine in the medical field.
- Transmission system allows maximum 5 cycles per minute.
- Do not use the engine continuously for more than two minutes, otherwise damage can be produced for which the manufacturer will not take the responsibility.
- The owner or user assumes full responsibility for the product when the engine is not used properly or is improperly repaired.
- Repairs should be performed only by authorized

person.

- If the power cord is damaged it must be replaced by the manufacturer, its service agent or a similarly qualified person in order to avoid danger.
- The manufacturer is not liable for damage caused by failure to observe these instructions.
- Used batteries should be disposed of properly.

Start up:

- Is the design of your bed the right one (no cross-bars at the bottom of the bed)?
- Make sure the engine is firmly fixed to the bed frame.
- Ensure that the engine frame has a uniform distance to the bed frame.
- Check the specifications to match those of your home (operating voltage).
- The wires must be routed so that damage is avoided. Unplug immediately if a wire is damaged.
- The motor frame is designed only to a change in position with a lying person. Please do not sit or stand on the ends of the bed.

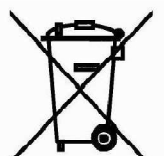
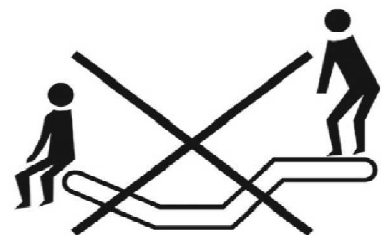

Installation instructions for engine swap:

- If the engine is not in the correct position for the installation, connect the plug and press the button 6 on the hand switch. The motor will move into position for installation.
- For security reasons again pull the plug from the socket. For an easy installation, place the bed frame upside down so the steel pipes face upwards. Now firmly press the engine through the nail-shaped projections until the tubes remain in the "u" form gap.
- Make sure the symbol for the back on the engine shows to the head of the bed frame. At the T5 Black the holes in the top of the engine are closed on the tubes with sliding covers, which fit into the center of the slot.
- After completing the installation, place the slatted frame on the bed frame and connect the plug, so the internal energy storage can recharge itself.
- Then place the battery.

Emergency lowering:

So you can leave the slatted frame in a reclining position at power failure, the bed has special equipment connected to an integrated of 9-V alkaline battery, which is automatically activated when pressing the button 6. If the hand switch fails, the "coding" button can be pressed on the engine. The download speed is reduced. Although the battery can hold several emergency descents, we recommend changing after each descent, or after a maximum of three years, due to the deterioration of the same.

Hand switch (functions):

- 1 – Back part up
- 2 – Back part down
- 3 – Foot part up
- 4 – Foot part down
- 5 – Foot and back part up
- 6 – Foot and back part down

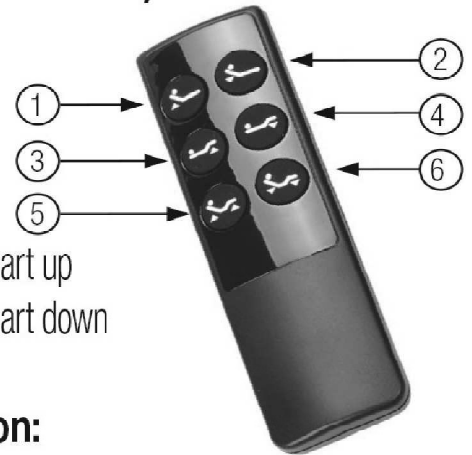

Synchronization:

- Hand switch with the motor: Keep pressing the button 2 and 3 at the same time and then press the "coding" button at the motor. A sound will be heard confirming synchronization.
- Hand switch with two engines: Keep pressing the button 2 and 3 at the same time and then press the "coding" button located in each of the two motors. A sound will be heard in both engines confirming synchronization.

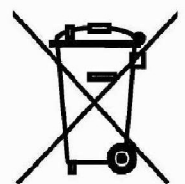
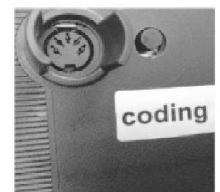

Technical data:

Connecting power supply

100-240 Volt AC 50-60 Hz.

The engine works with a DC voltage of 24 V DC.

Maximum connection time: 10% with continuous operation is 2/18 minutes.

Operating voltage for the hand switch is 24 V DC.

Power required, depending on load and models:

30-300 W.