

REPC-Nr.:

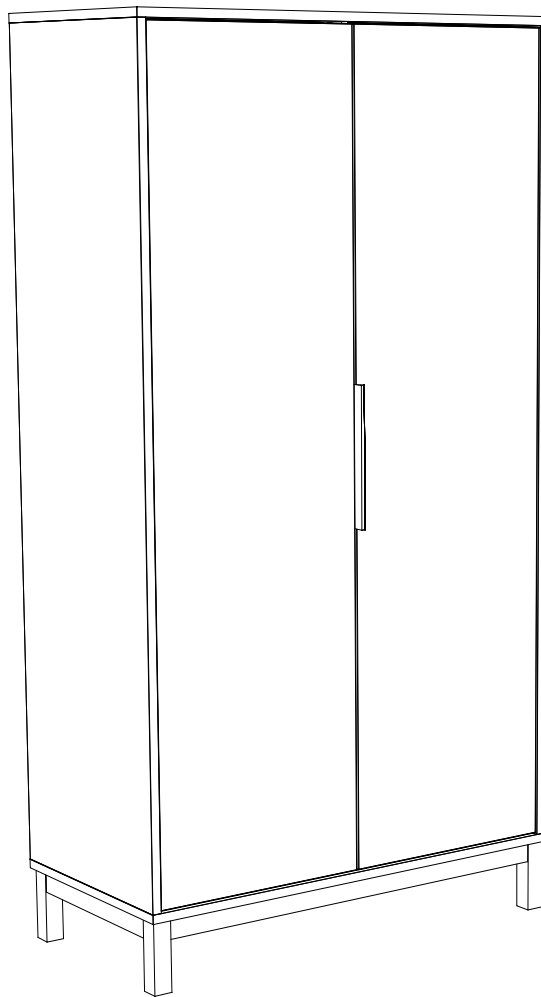

Artikel.-Nr.:

4004-KS-2

Montageanleitung.-Nr.:

MA1-00830

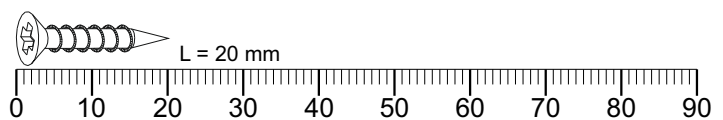
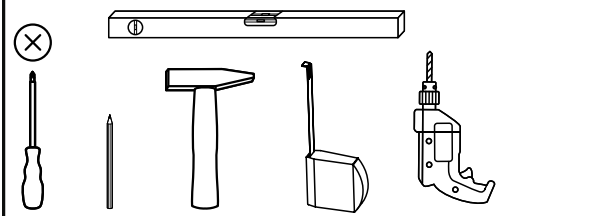
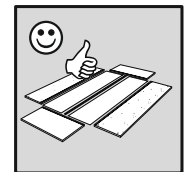
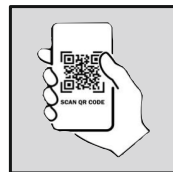
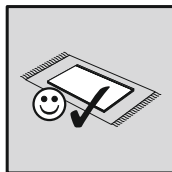
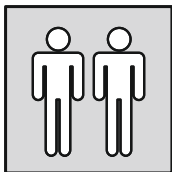
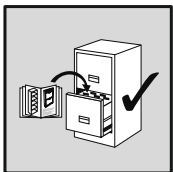

Das Ersatzteil-Anforderungsformular finden Sie auf
The replacement parts requisition form you find on
<https://www.mausbacher.de/ersatzteile/>

Colli 1/3

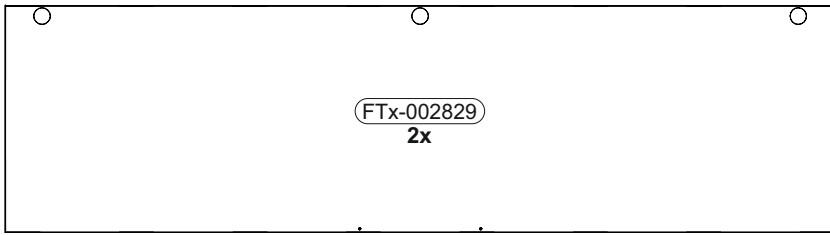

1756 x 480

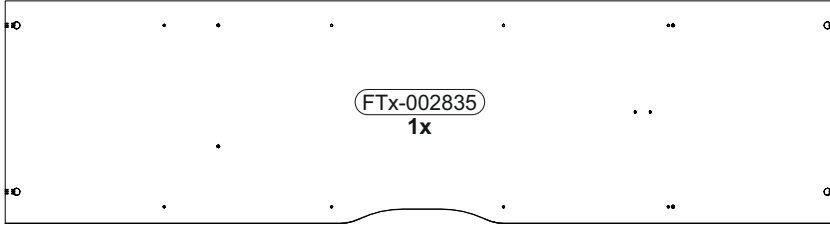

1764 x 471

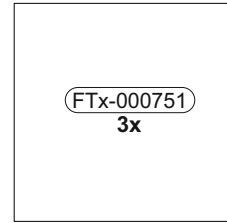

468 x 461

Colli 2/3

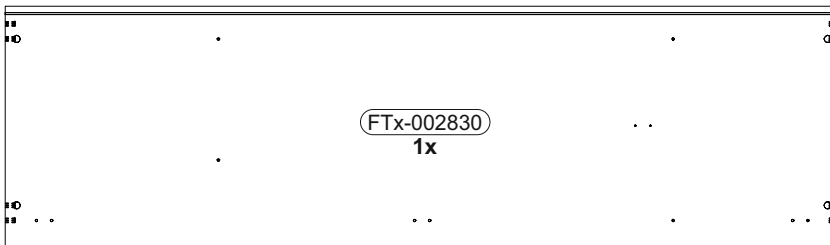

1764 x 508

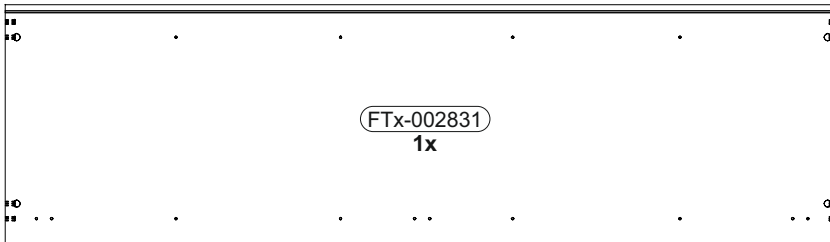

1764 x 508

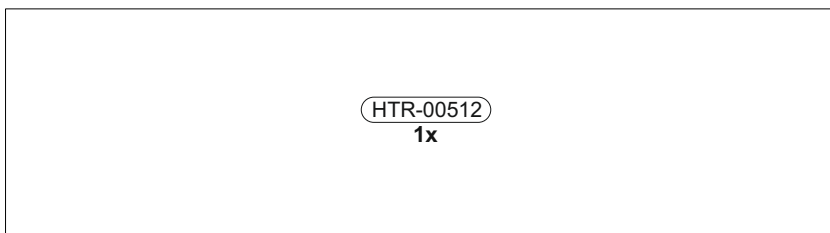

1776 x 480



1776 x 497

BT1-00918

B01-10 5x 6,3x50	B01-174 7x 4,5x50	B01-200 2x 6,3x13
B01-30 23x 3x16	B01-80 16x 3,5x13	B01-90 6x 3,5x20
B02-103 8x 8x30	B02-114 2x	B02-160 13x
B05-185 6x	B08-80 1x	B02-10 26x ø15x12mm

BT1-00919

B03-03 6x	B03-05 6x
B06-423 1x 300mm	

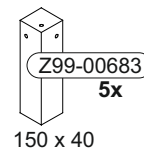
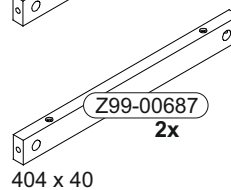
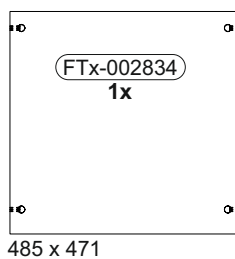
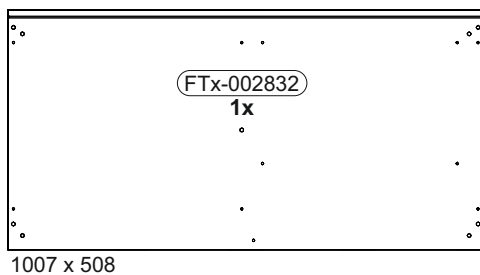
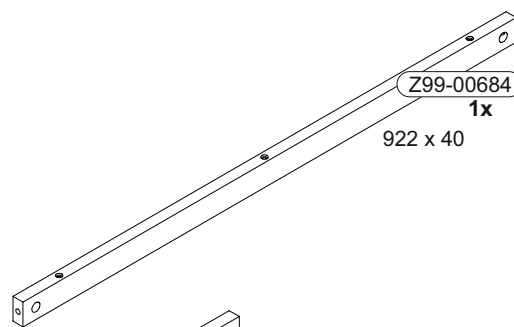
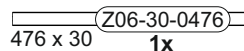
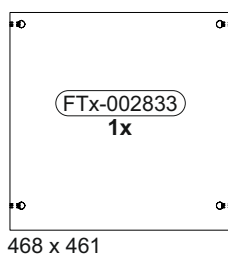
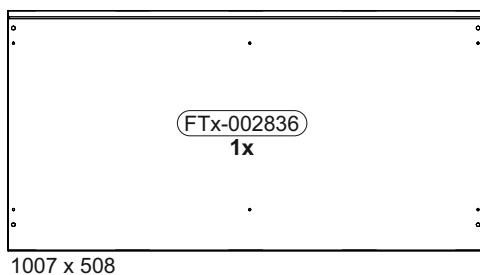

1

	B02-10 14x ø15x12mm
--	---------------------------

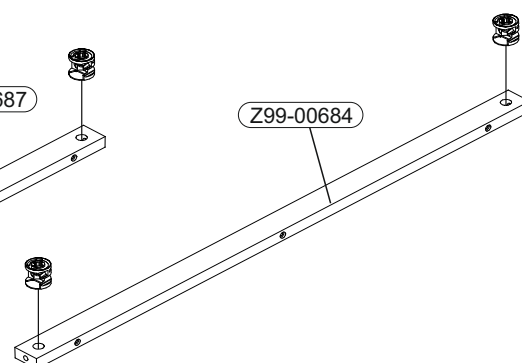
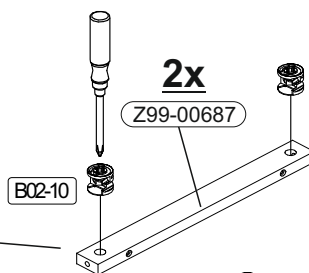
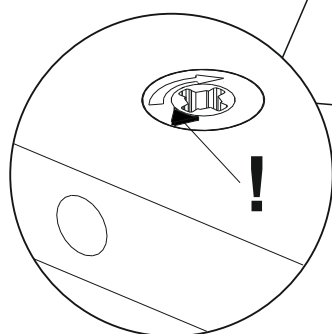
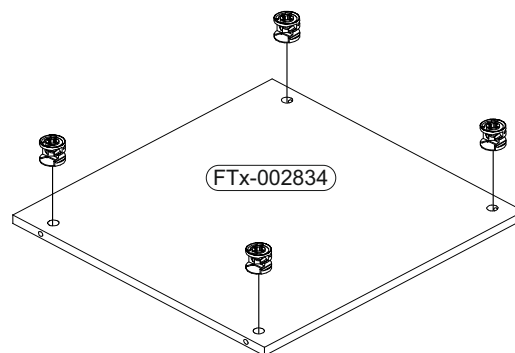
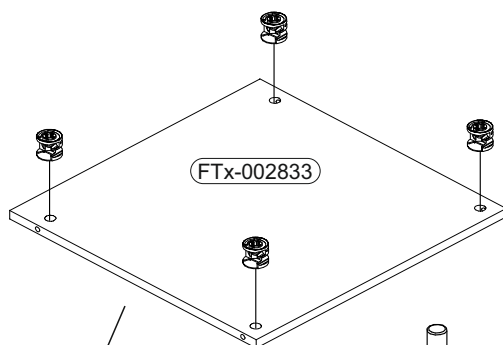

2

		B02-20		B03-05		B02-160		B02-103		B02-10	
		2x		3x		6x		4x	8x30	4x	ø15x12mm

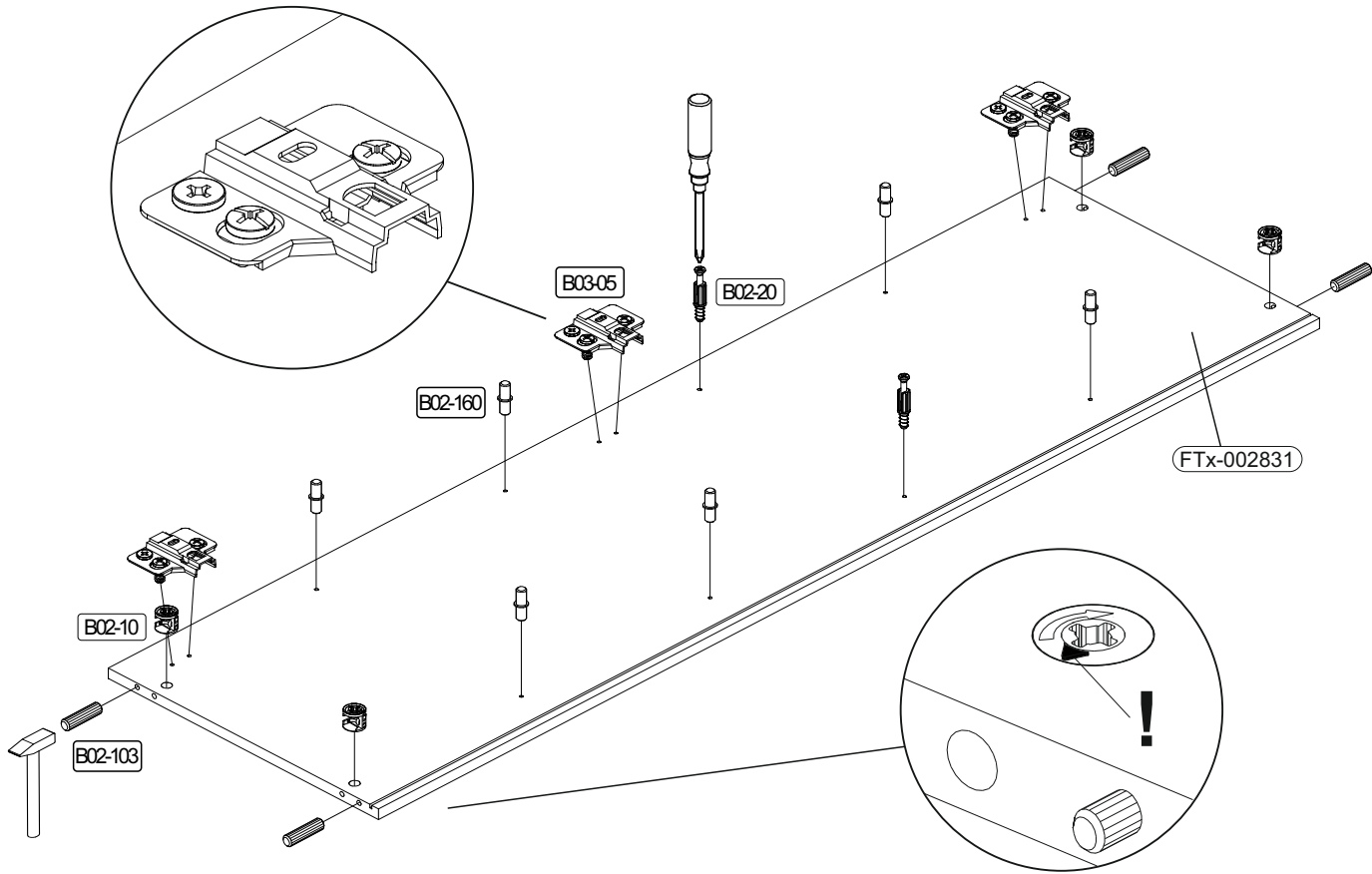

3

		B02-20		B03-05		B02-114		B02-103		B02-10	
		2x		3x		1x		4x	8x30	4x	ø15x12mm
		B01-80									
		2x	3,5x13								

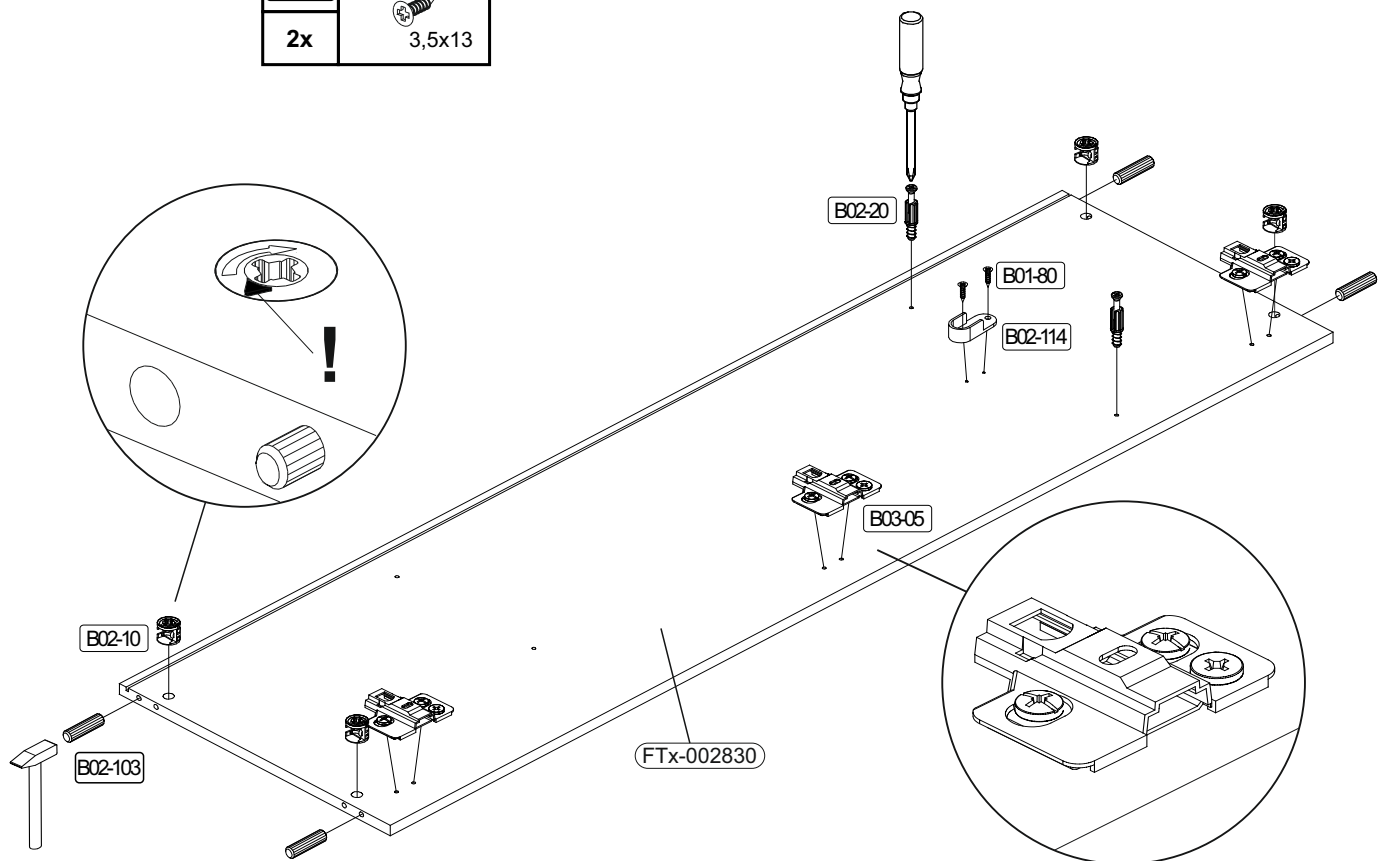

4

	4x	4x	6x	1x	2x	

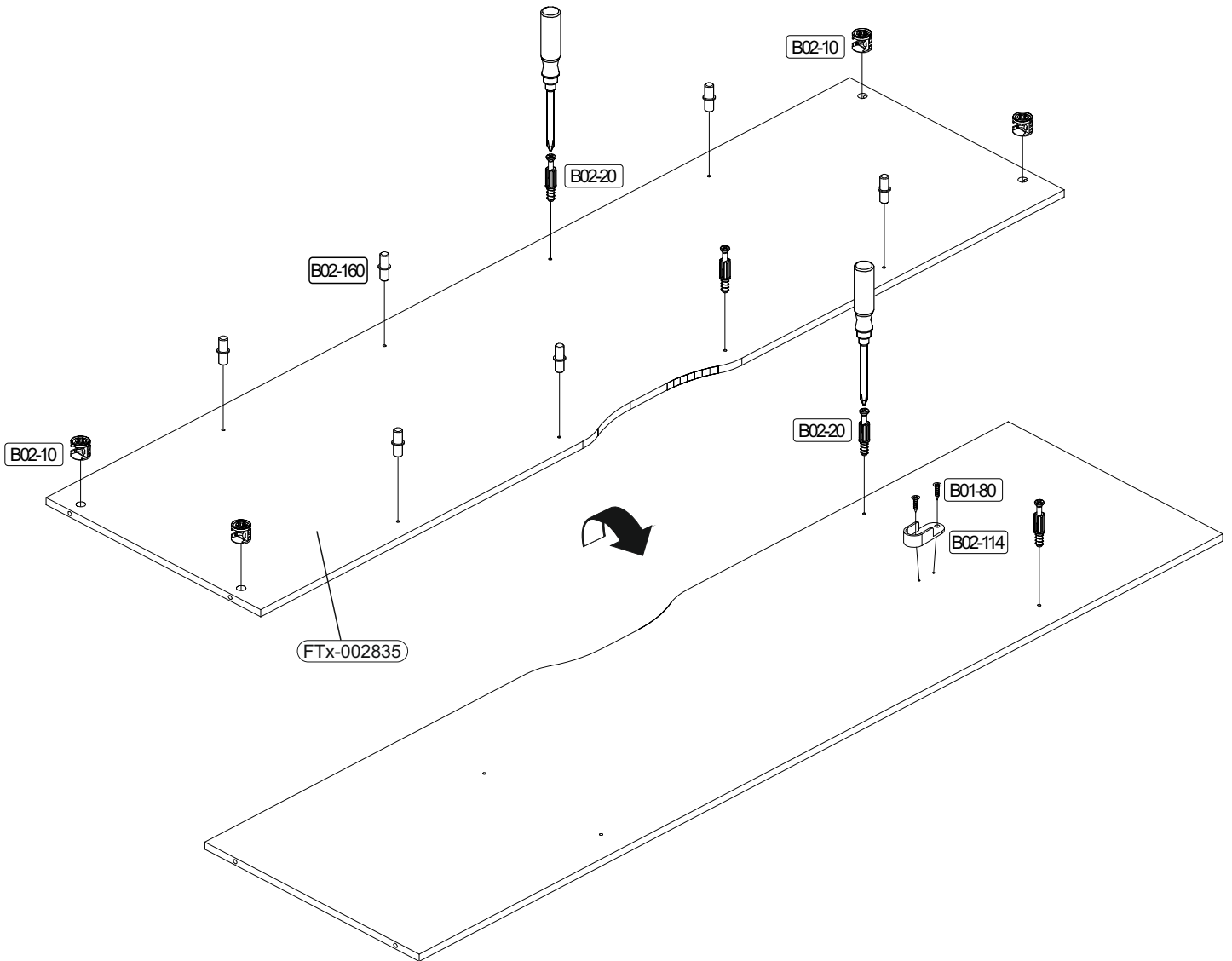

5

	6x	

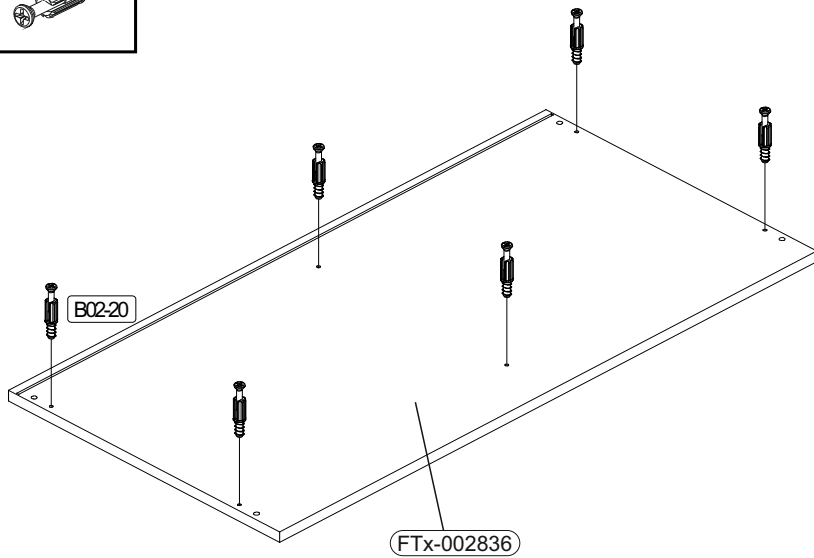

6

	B01-10		B02-20		B02-160	
	5x		12x		1x	
	B01-174					
	7x					

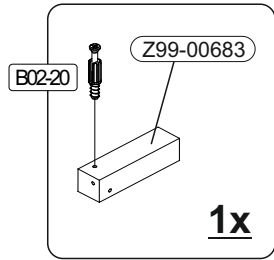
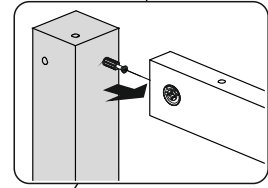
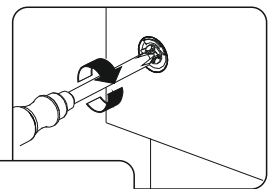

1x

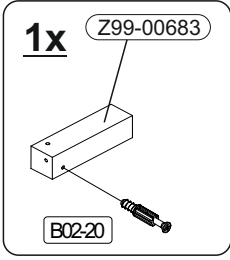

1x

1

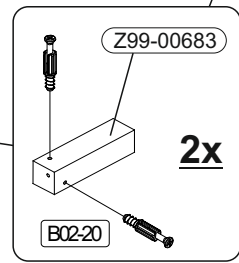

2x

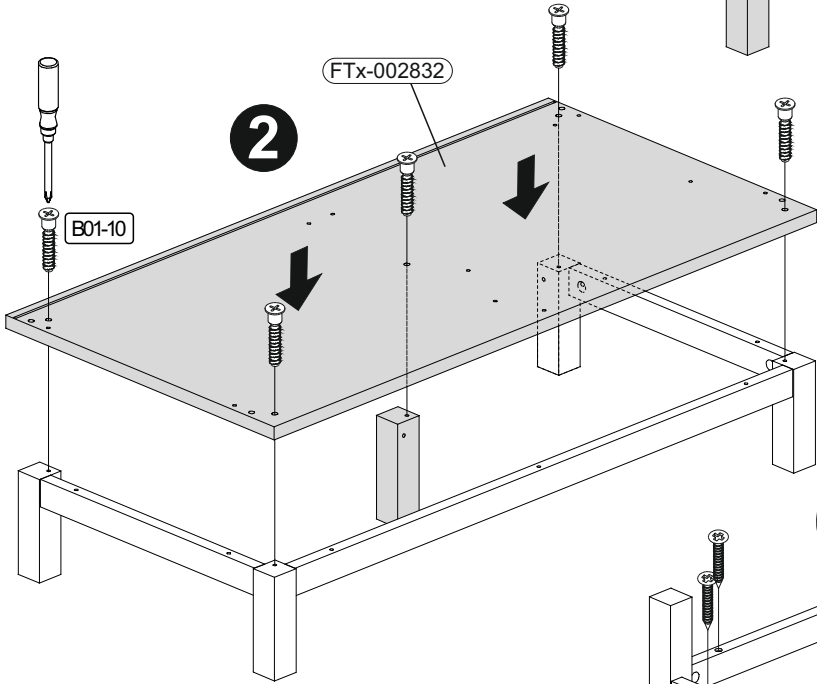

2

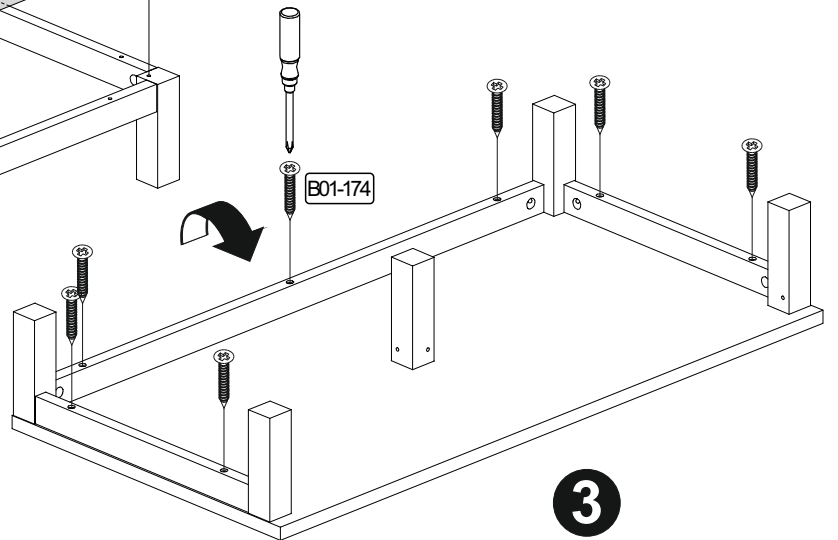

3

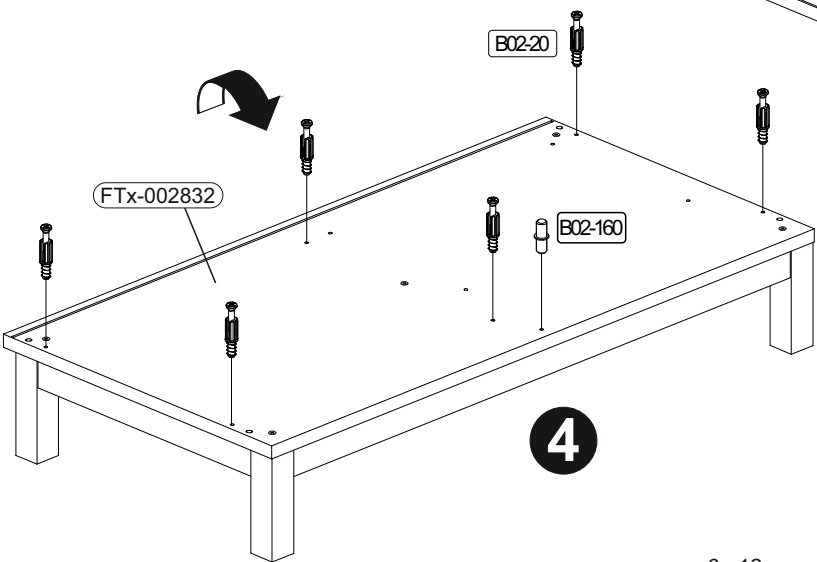

4

7

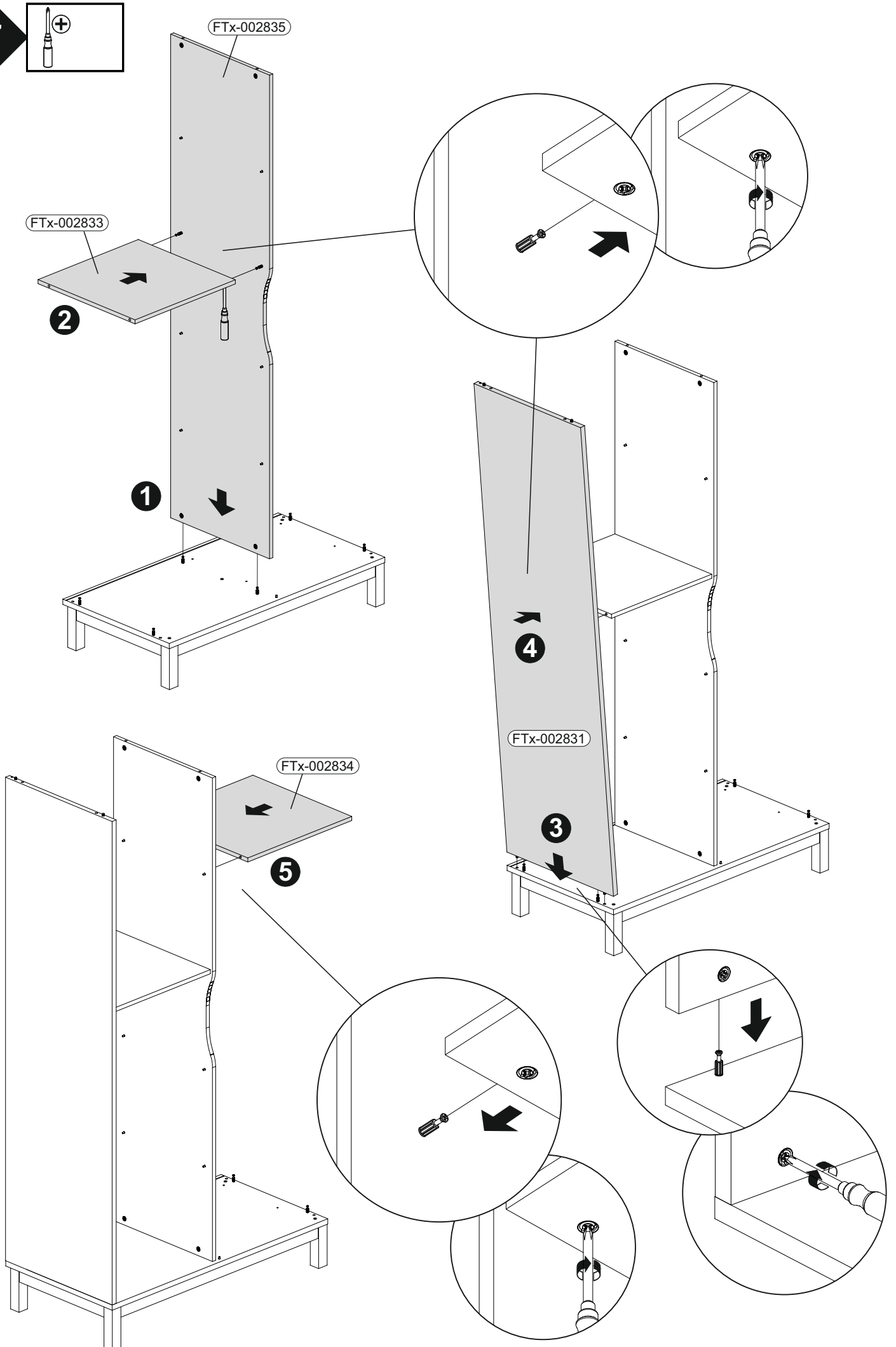
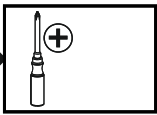

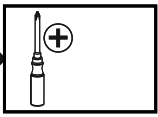
8 

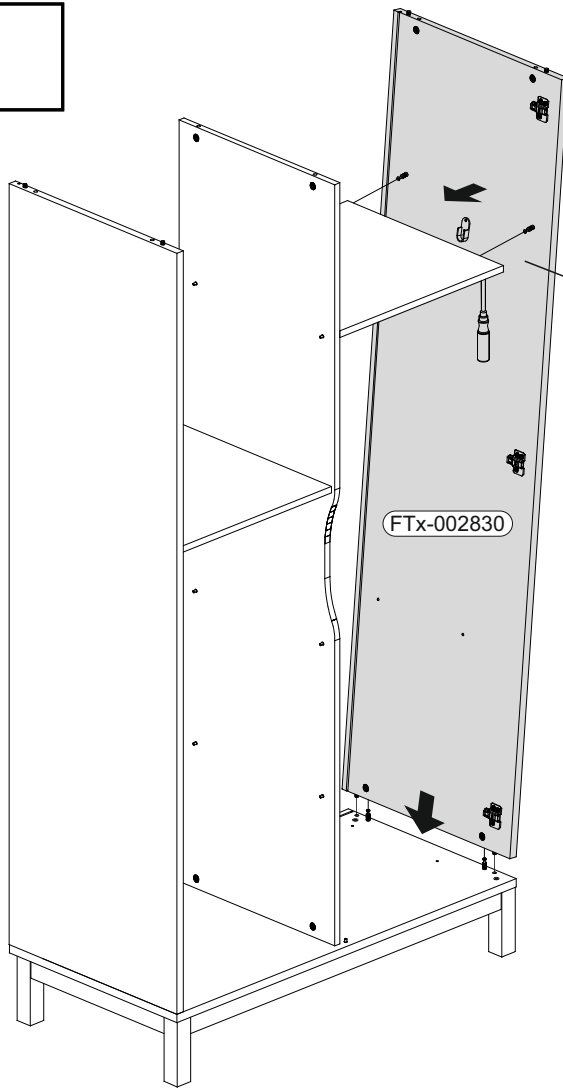

2

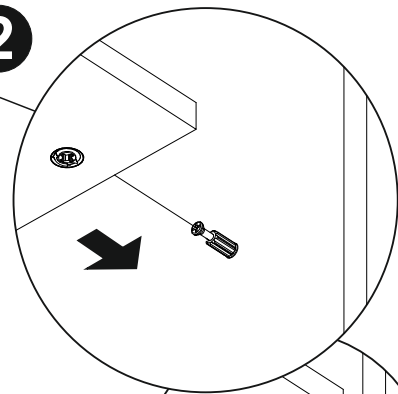

1

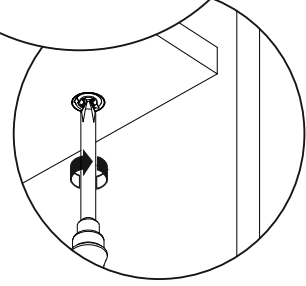

4

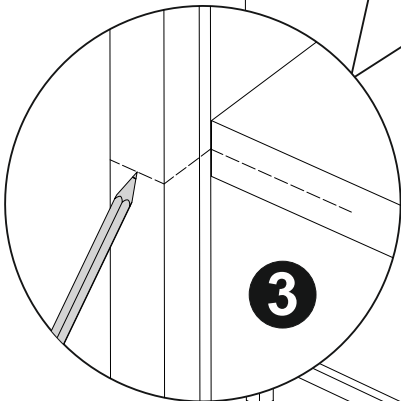
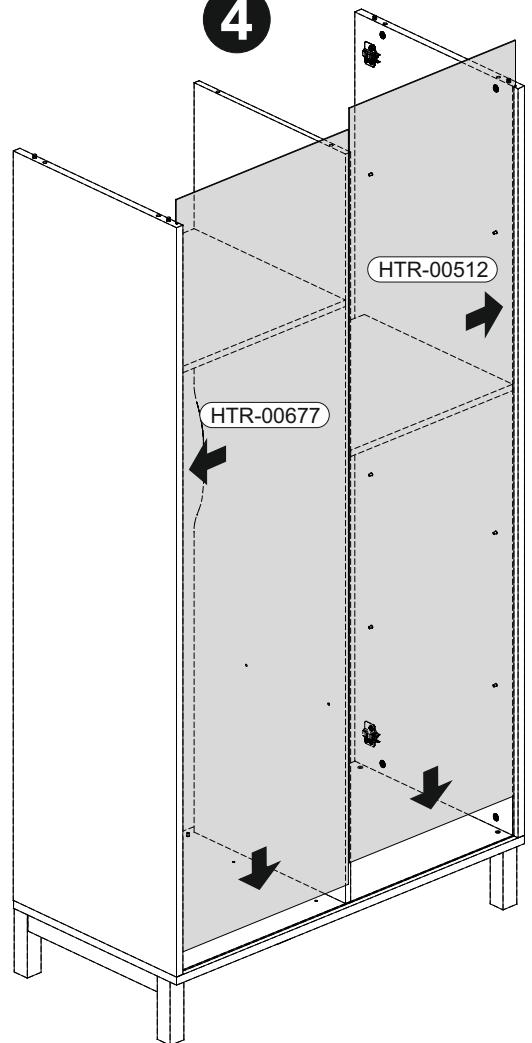

3

9

	B01-30	
23x		3x16
B05-185		
6x		
B01-90		
6x		3,5x20

1

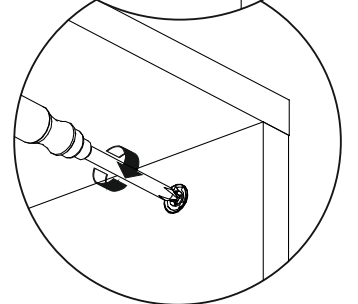
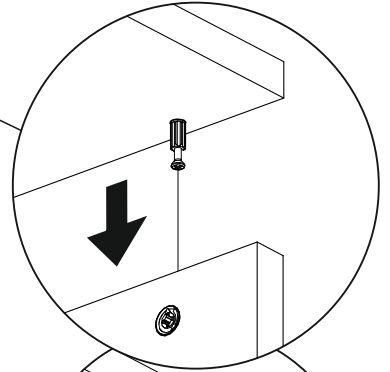
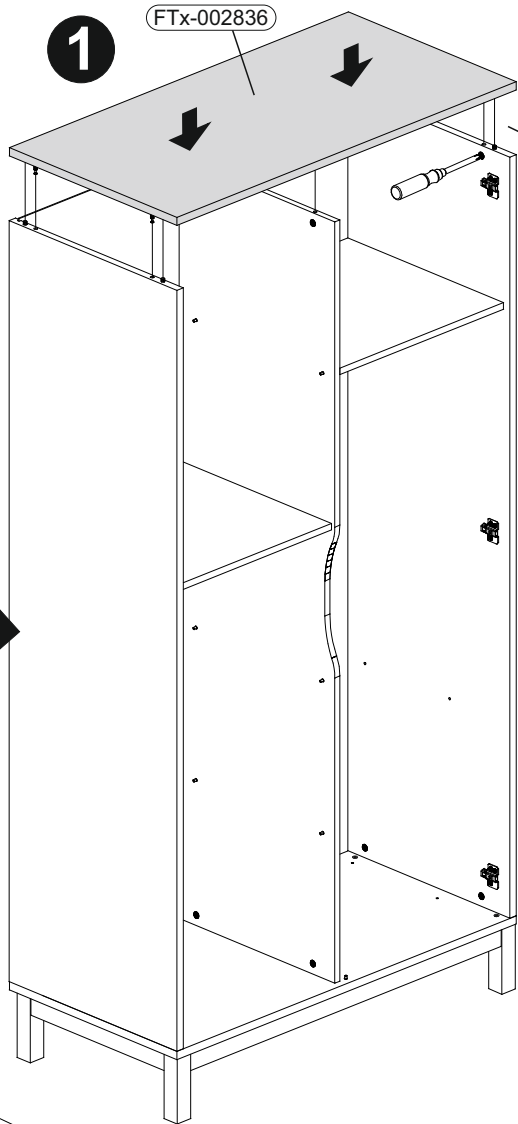

3

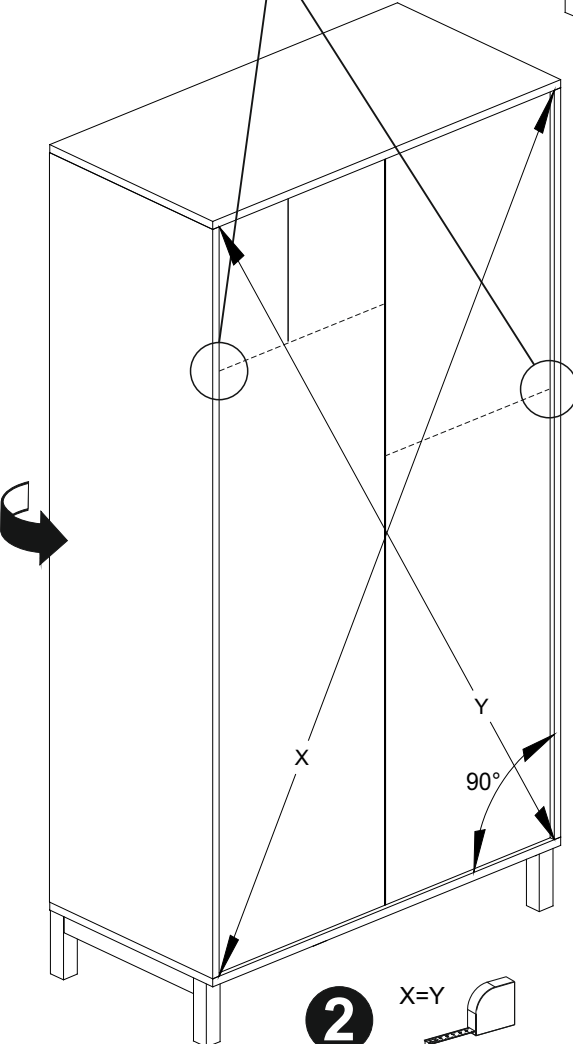
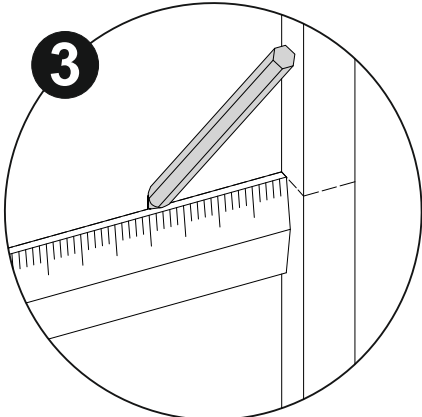

2

X=Y

4

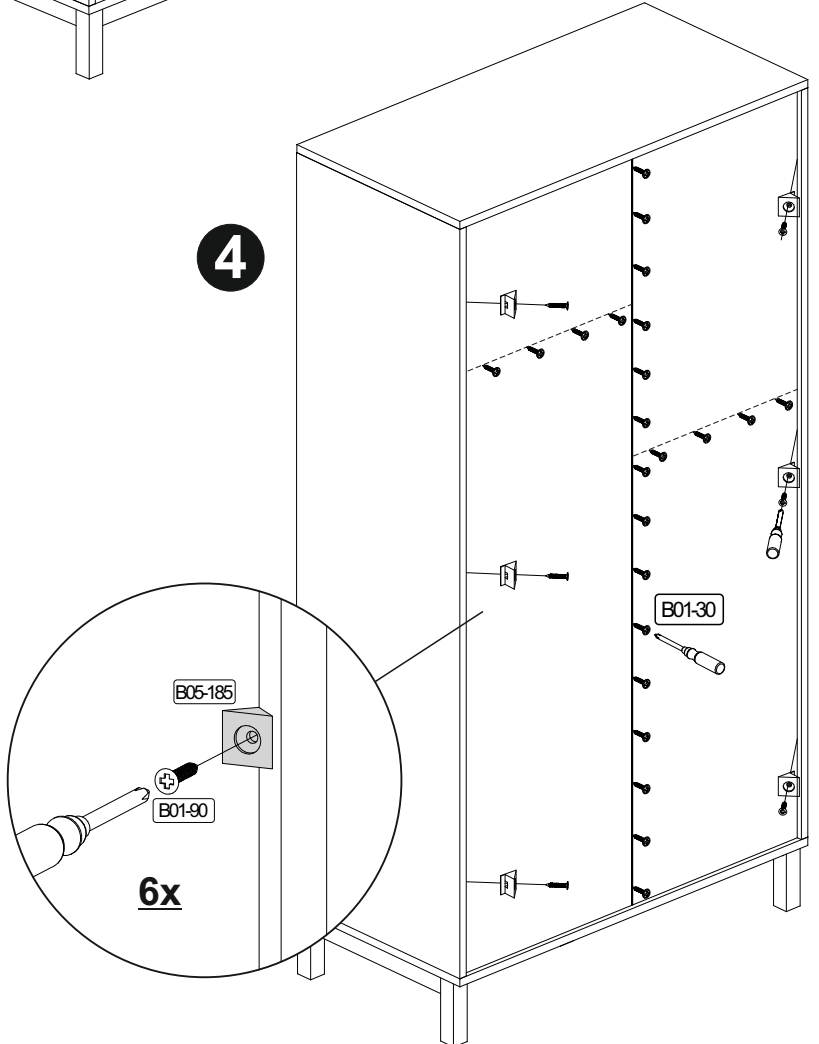

10

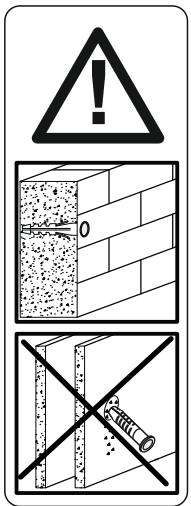
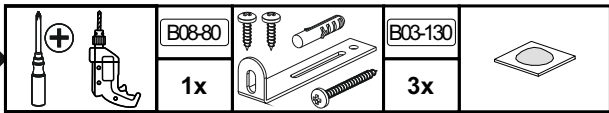

1

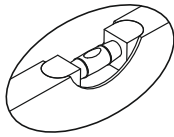

2

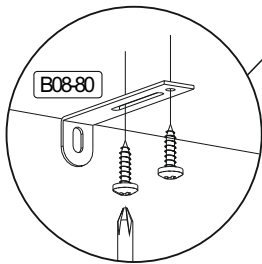

3

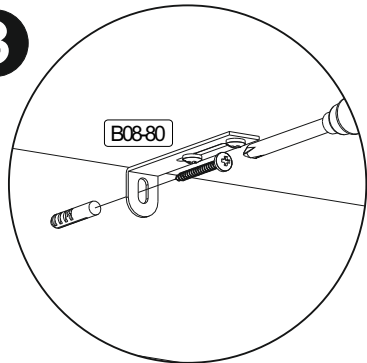

4

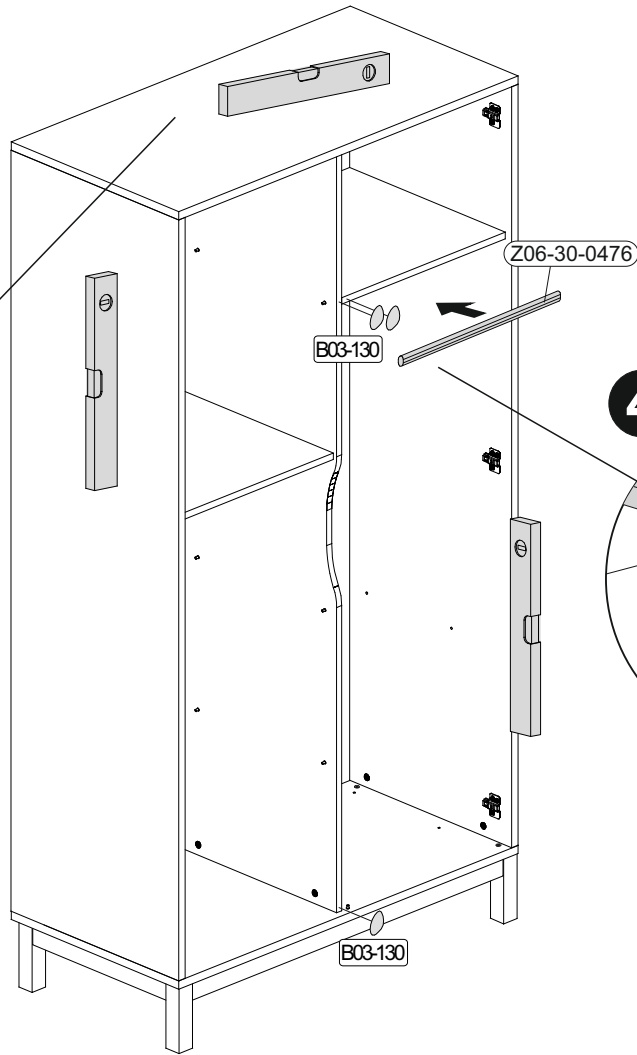
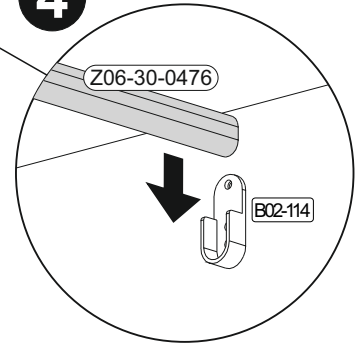

Achtung • Attention • Attenzione • Opgelet • Uwaga • Pozor • Figyelem • Atenție • Dikkat • Внимание • Fara • Vaara • Fare • Peligro	
D	Wandbefestigung dient als Kippschutz - unbedingt anbringen! Bei einigen Wandtypen kann ein Spezialdübel erforderlich sein!
GB	The wall fastening serves to prevent tipping - be absolutely sure to mount it! For certain wall types, a special wall plug may be necessary!
FR	La fixation murale sert de protection contre le basculement – à installer impérativement ! Pour certains types de murs il faut des chevilles spéciales !
TR	Duvardaki sabitleme, devrilmeye karşı bir emniyet tedbiridir ve mutlaka monte edilmelidir! Bazı duvar tiplerinde bunun için özel bir dübel gerekli olabilir!
IT	Il fissaggio alla parete serve da protezione anti-ribaltamento – attaccarla assolutamente! Per alcune strutture di parete può essere necessario un tassello speciale!
NL	Bevestiging aan de muur dient als kantelbescherming – zeker en vast bevestigen! Bij enkele muurtypes is een speciale plug misschien vereist!
RU	Обязательно установите крепление на стене во избежание опрокидывания! Для некоторых типов стен может потребоваться специальный дюбель!
CZ	Montáž na stěnu slouží jako ochrana proti převrnutí – bezpodmínečně umístěte! U některých typů stěn může být zapotřebí speciální hmoždinka!
HU	A termék a falhoz kel rögzíténi, különben az felborulhat! Egyes faltípusoknál speciális tiplit kell használni!
RO	Sistemul de fixare la perete servește ca protecție la răsturnare - de montat obligatoriu! Pentru unele tipuri de pereți este posibil să fie necesar un diblu special!
PL	Mocowanie do ściany jest jednocześnie zabezpieczeniem przed przewróceniem – koniecznie zamontować! Do niektórych rodzajów ścian koniecznie zastosować specjalne kołki mocujące.
SWE	Väggmontering fungerar som anti-lutningskydd - det är viktigt att fästa det! En speciell plugg kan behövas för vissa väggtyper!
FIN	Seinäkiinnitys toimii kaatumista estävänä suojana - se on ehdottomasti kiinnitettävä! Joihinkin seinätyyppeihin voidaan tarvita erityistappi!
NOR	Veggmontering fungerer som anti-vippebeskyttelse - det er viktig å feste det! En spesiell dyvel kan være nødvendig for noen veggtyper!
DAN	Vægmontering fungerer som anti-vip beskyttelse - det er vigtigt at fastgøre det! En speciel dyvel kan være påkrævet til nogle vægtyper!
SK	Upevnenie na stenu slúži ako ochrana proti prevráteniu – bezpodmienečne použite! Pre niektoré druhy stien môže byť potrebná špeciálna hmoždinka!
ES	El montaje en la pared sirve como protección antivuelco: ¡es imprescindible fijarlo! ¡Es posible que se requiera una espiga especial para algunos tipos de paredes!

11

	B03-03		B06-423		B01-200		B01-80	
	3x		1x	300mm	2x	6,3x13	6x	3,5x13

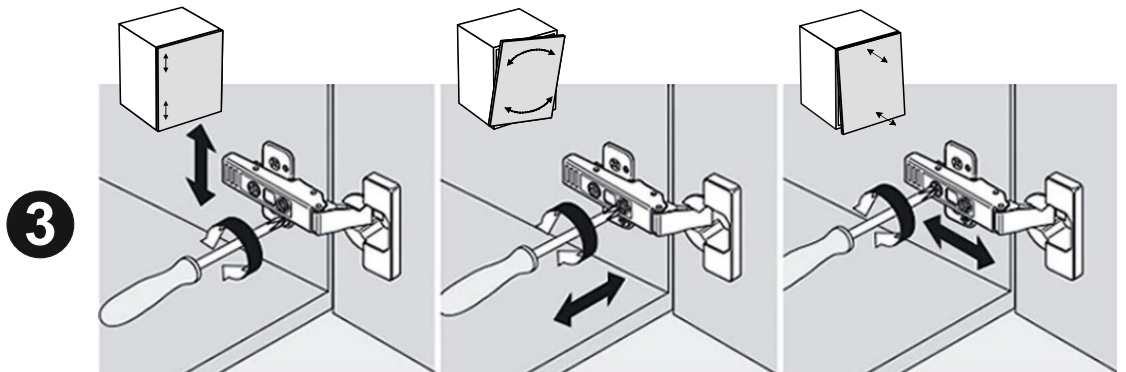
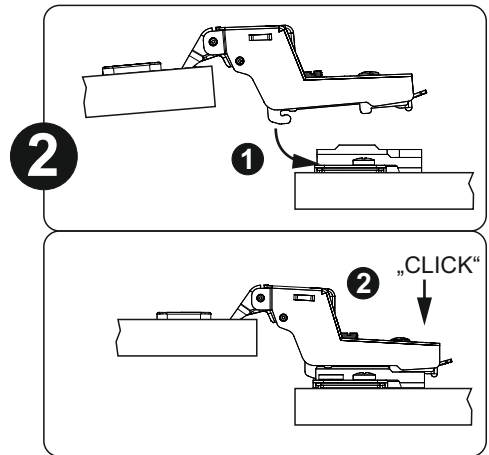
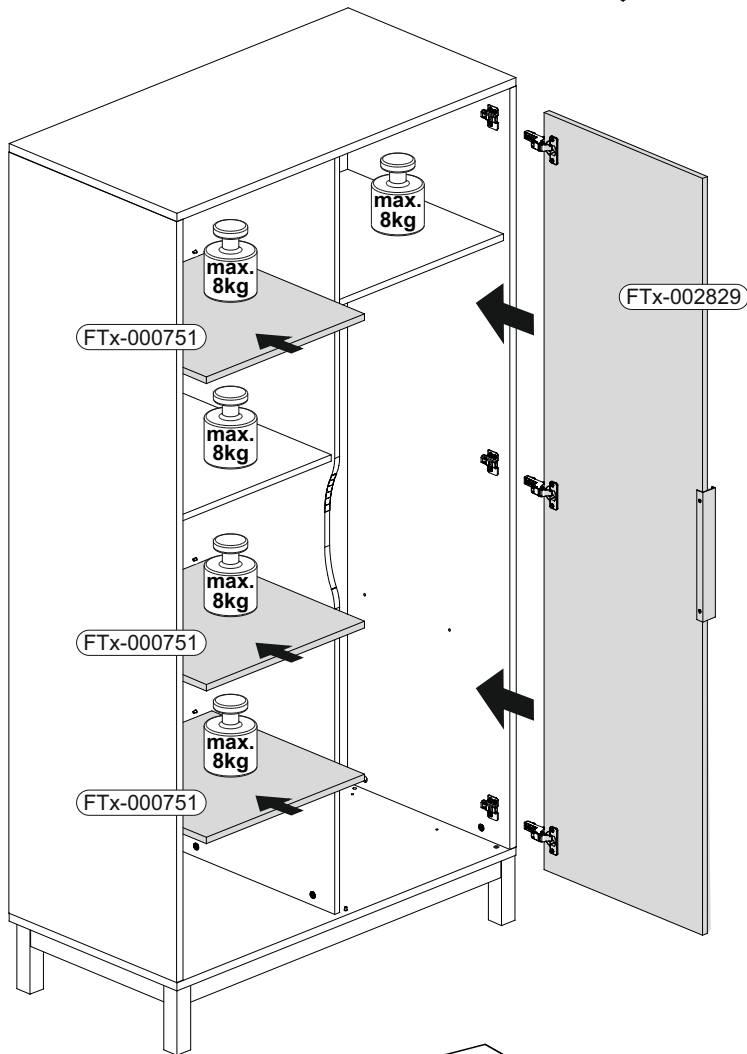
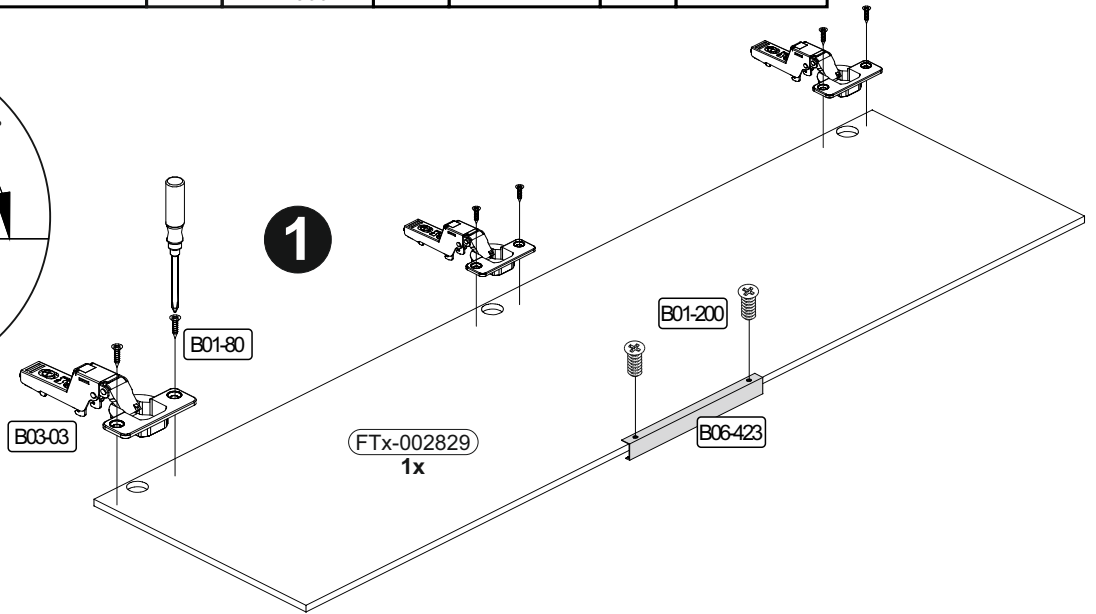
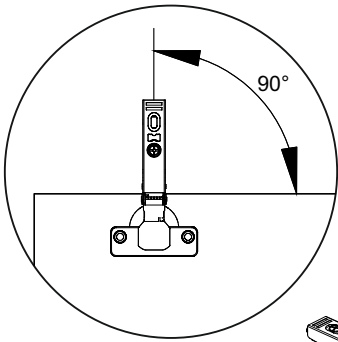

12

	B03-03		B01-80	
3x		6x		3,5x13

