

Modell: FREDERICA 21

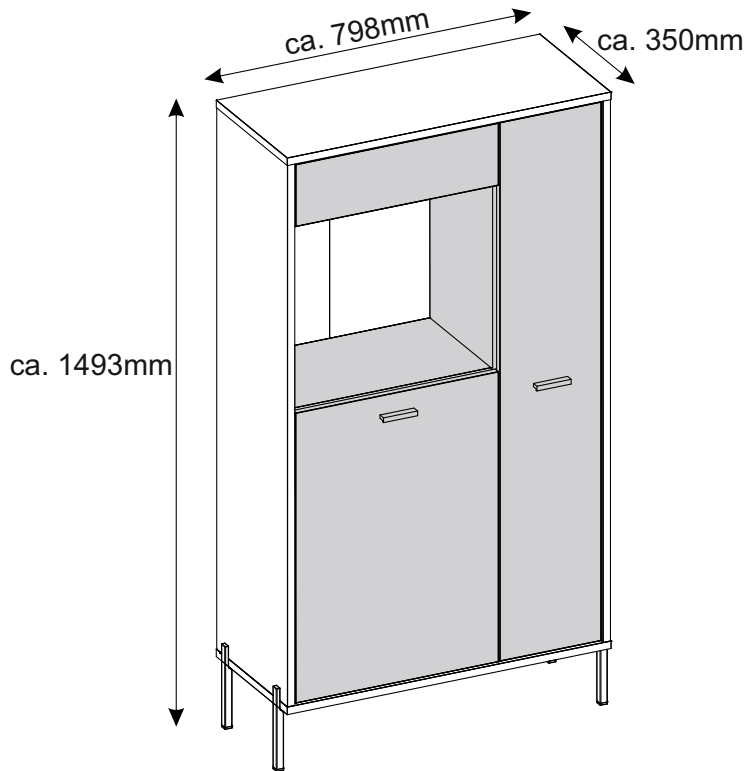

- Ⓛ Montageanleitung
- ⓃL Handleiding voor de montage
- ⓂR Montaj talimati
- Ⓛ Notice de montage
- ⓃZ Montážní návod
- ⓂU Szerelési útmutató
- ⓂB Assembly instructions
- ⓂL Instrukcja montażu
- ⓂU Инструкция по монтажу
- ⓂT Istruzioni di montaggio
- ⓂK Návod na montáž
- ⓂO Instrucțiuni de montaj
- ⓂS Instrucciones de montaje
- ⓂR Montaj Talimati

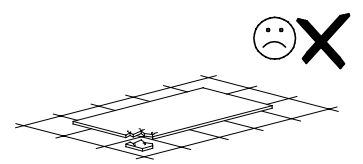

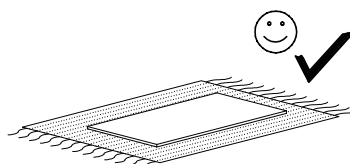
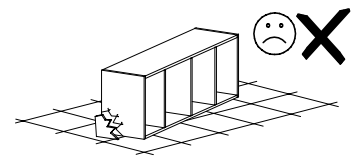
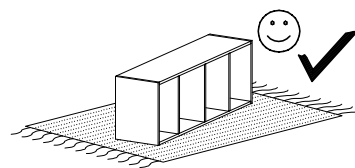
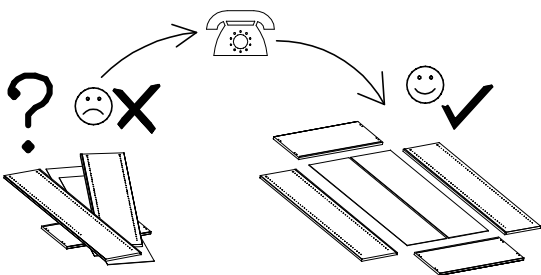
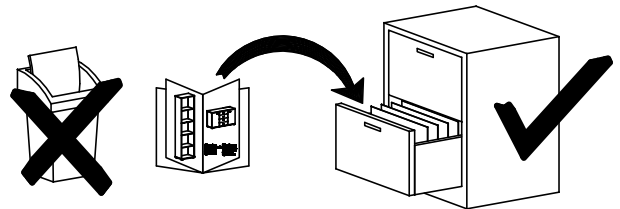
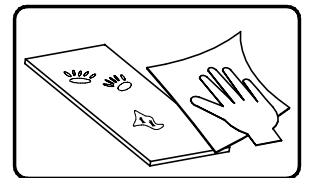
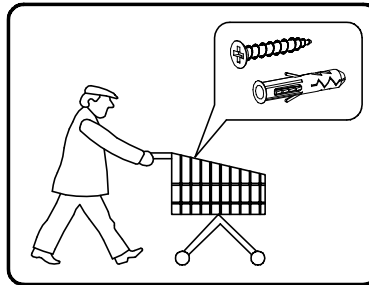
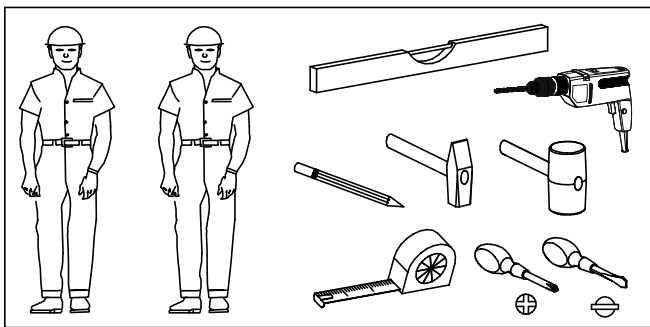
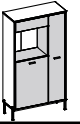

nr	L[mm]	B[mm]	T[mm]	Menge	Colli
1	1307	349	18	1	1/2
2	1307	349	18	1	1/2
3	1307	309	16	1	2/2
4	798	350	18	1	1/2
5	497	302	16	1	2/2
6	798	350	18	1	1/2
7	497	304	16	1	2/2
8	500	150	16	1	2/2
9	700	500	16	1	2/2
10	510	490	4	1	2/2
11	1300	250	16	1	2/2
12	304	247	16	2	1/2
13	1317	510	3	1	1/2
14	1317	260	3	1	1/2

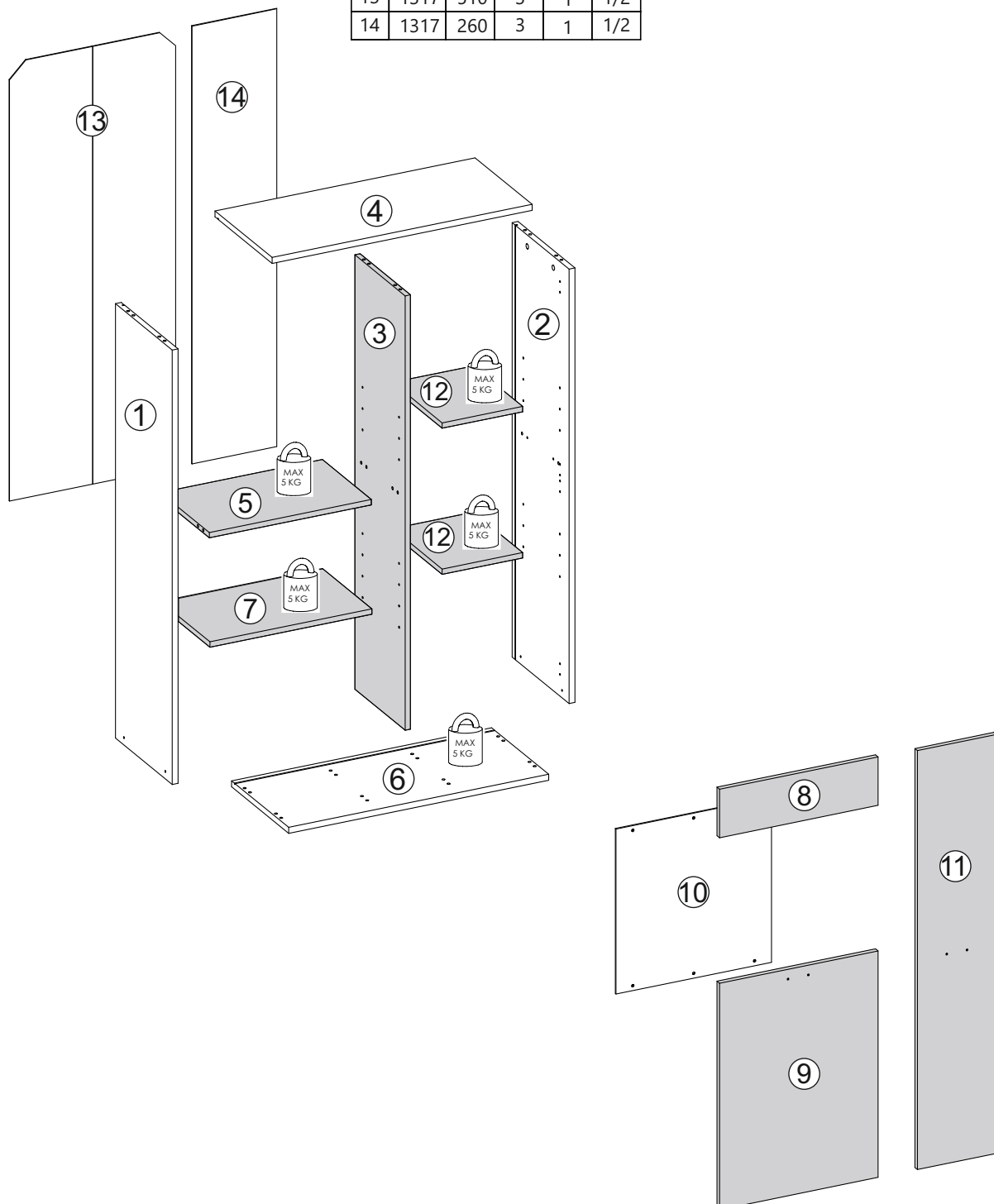

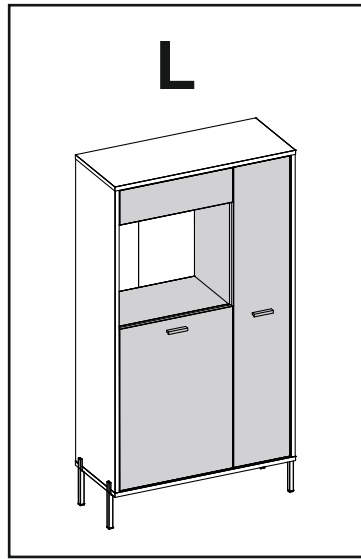
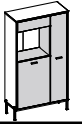

4/23 - 12/23

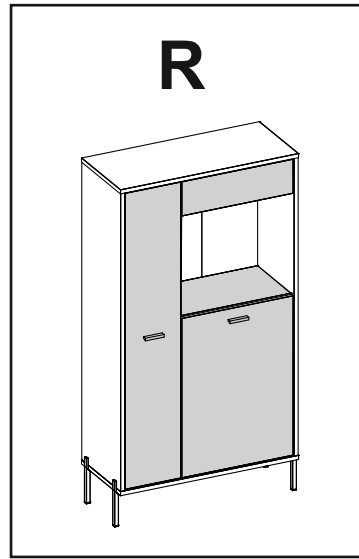

13/23 - 21/23

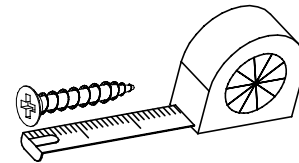
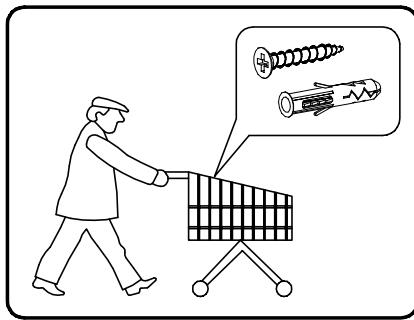

B1 3003605 ø8x35 x16	A1 3000534 ø7x50 x8	W2 3000331 x1	K1 3001728 15x12 x8	K10 3002942 x8
G34 3000574 3,5x16 x14	G50 3003843 3x20 x12	F20 3004583 x6	I7 3020881 x6	M11 3002892 x2
I1 3000344 x14	Z6 3002435 x8	C10 3015877 x6	P8 3027556 x4	N4 3028367 6x25 x4
G49 3005411 4x16 x22	U8 3028357 x2	N2 3000562 4x22 x4	F2 3000545 x12	I8 3024202 x4

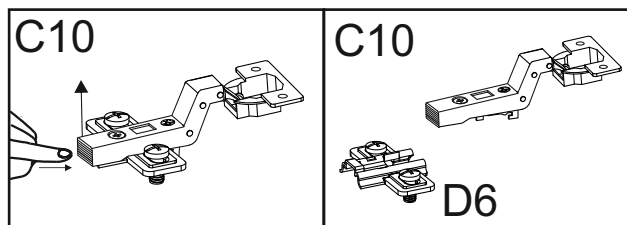

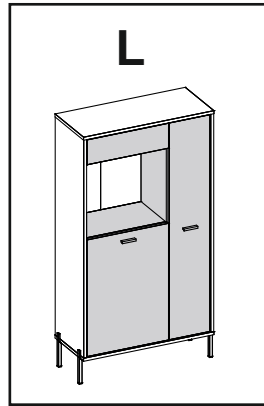
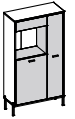

4/23 - 12/23

I

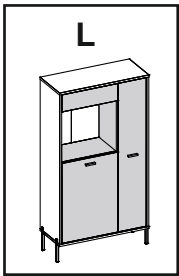

B1

∅8x35



x8

K1



x4

D6

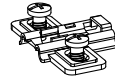

x6

K10

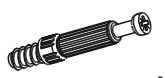

x2

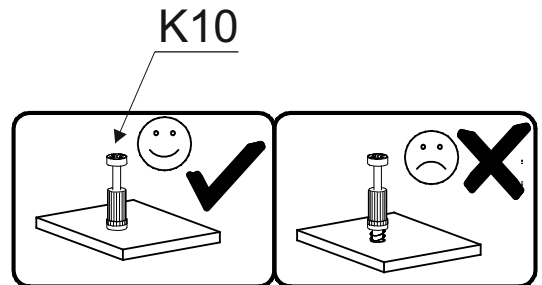
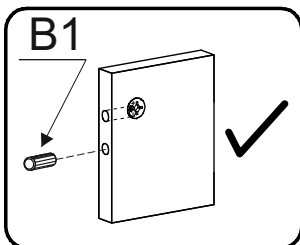
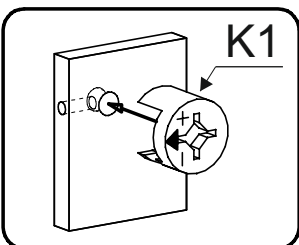
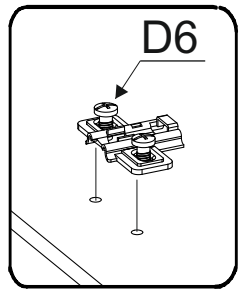
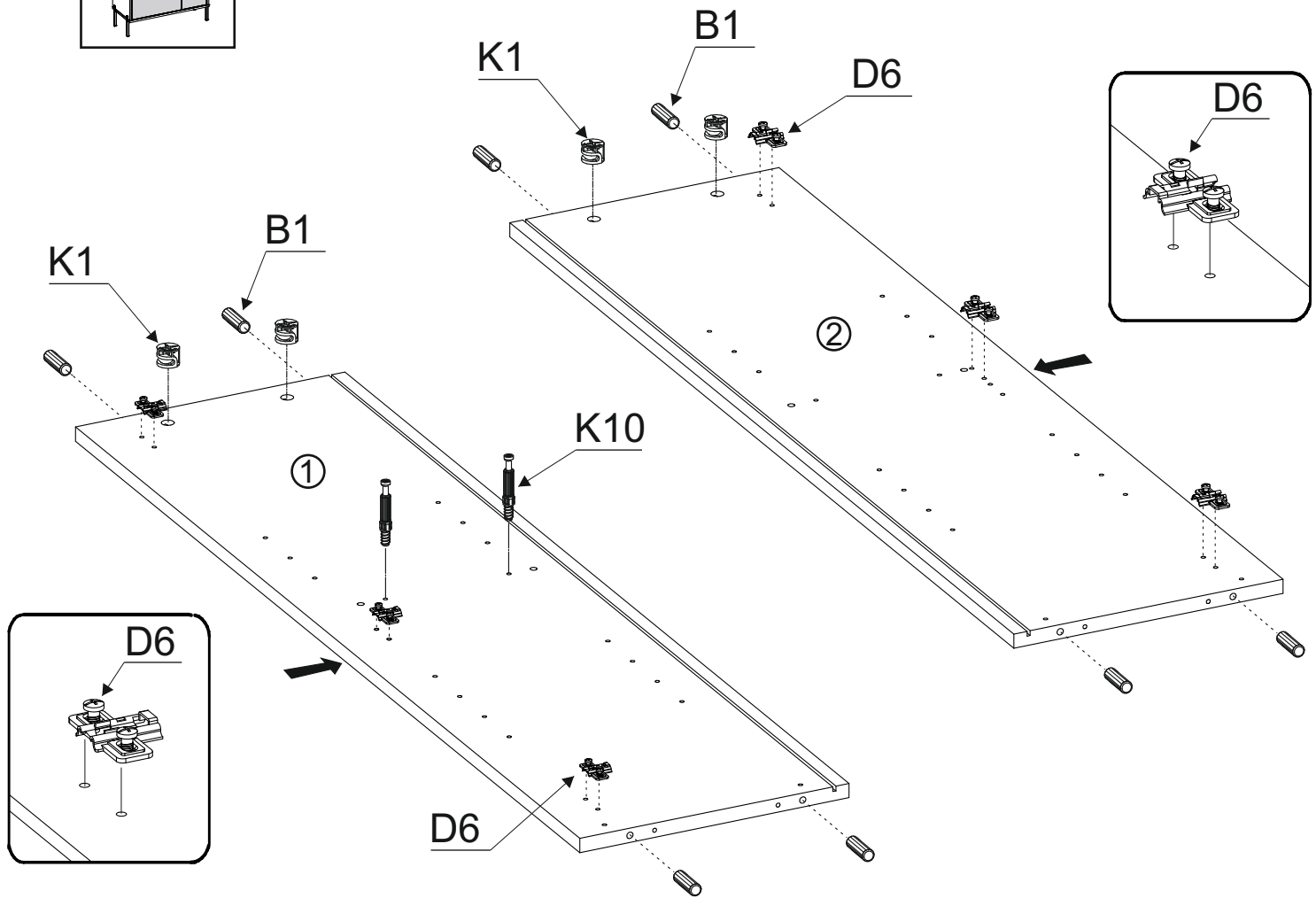

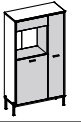

II

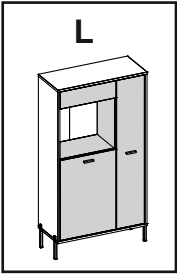

B1

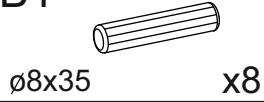

K1



K10

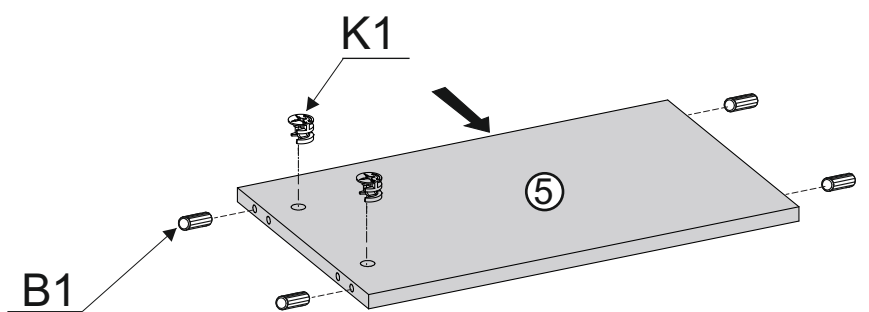
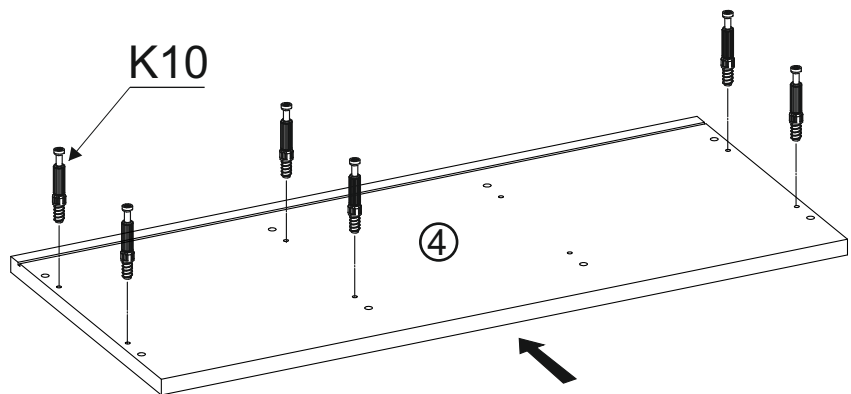
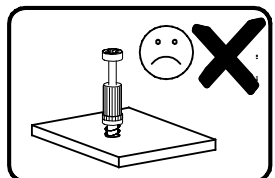
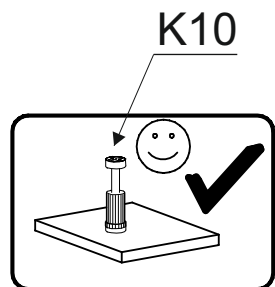
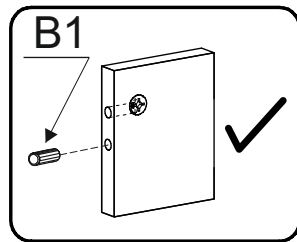
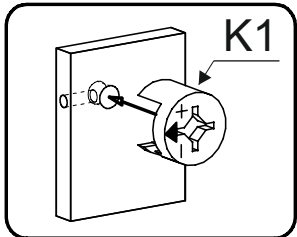
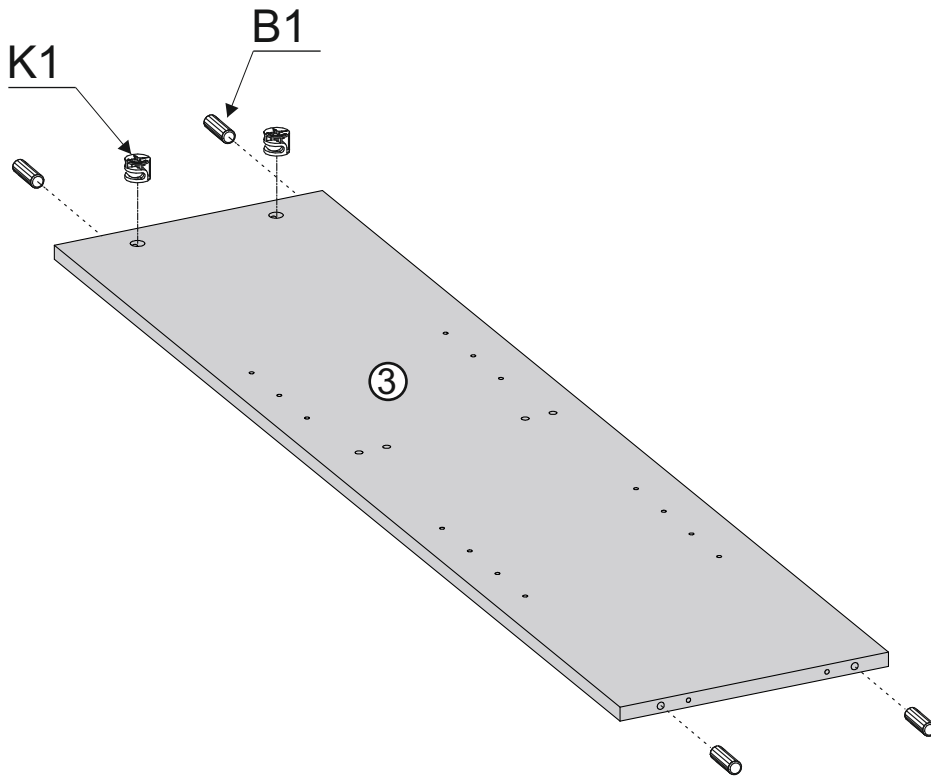

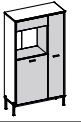

III

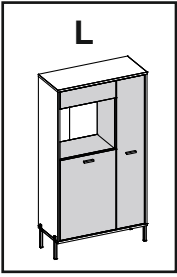

A1



ø7x50

x2

W2

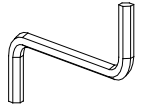

x1

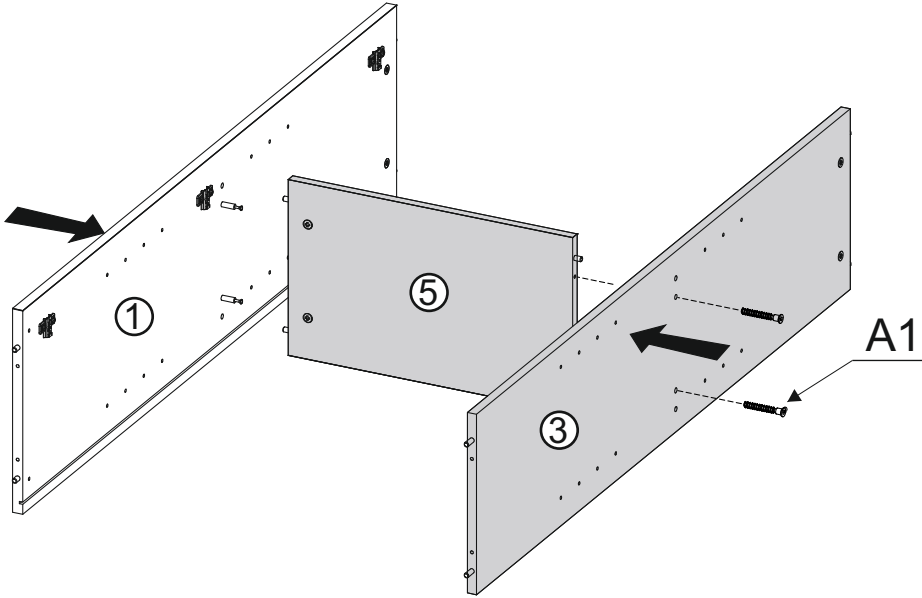
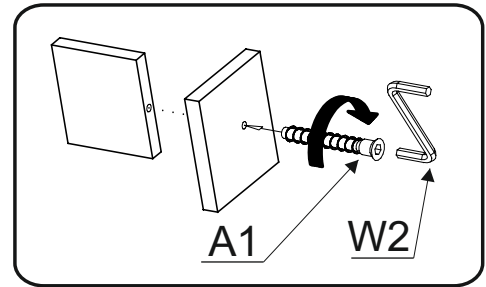
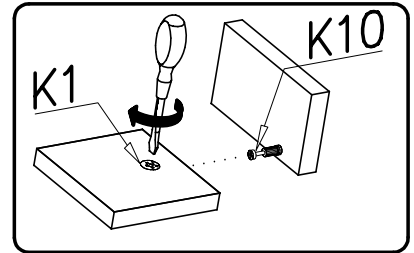

IV

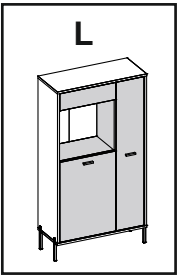

A1



ø7x50

x4

W2

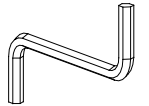

x1

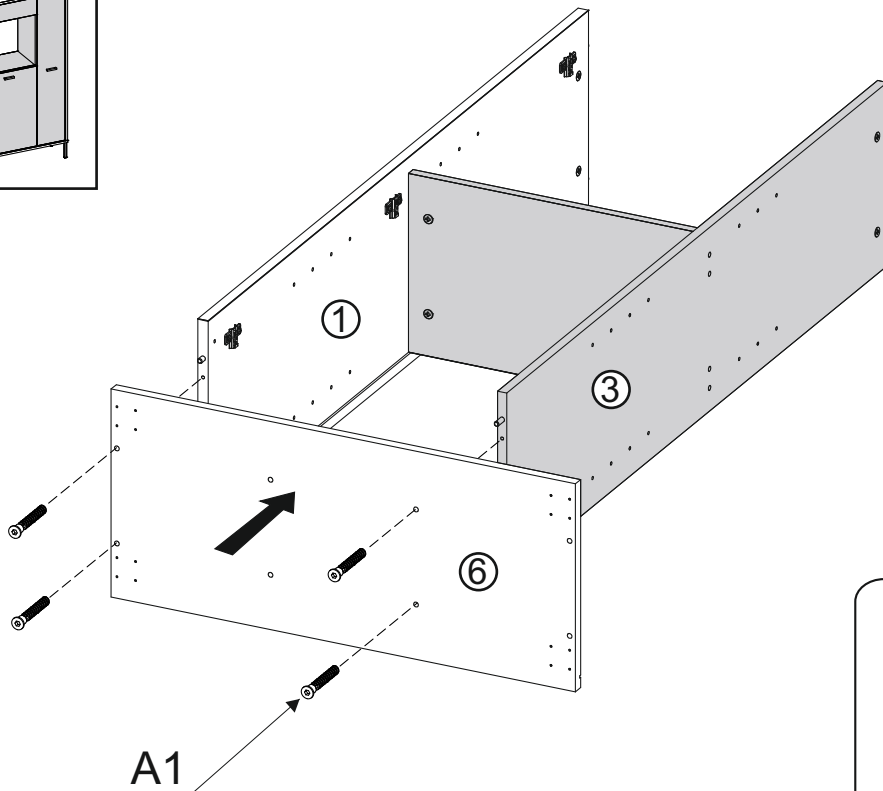
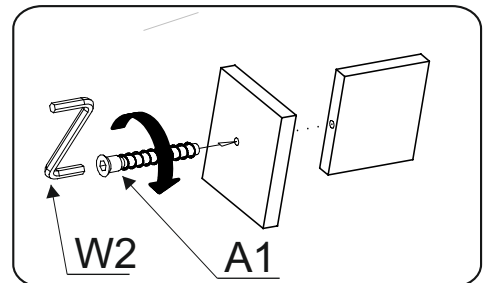

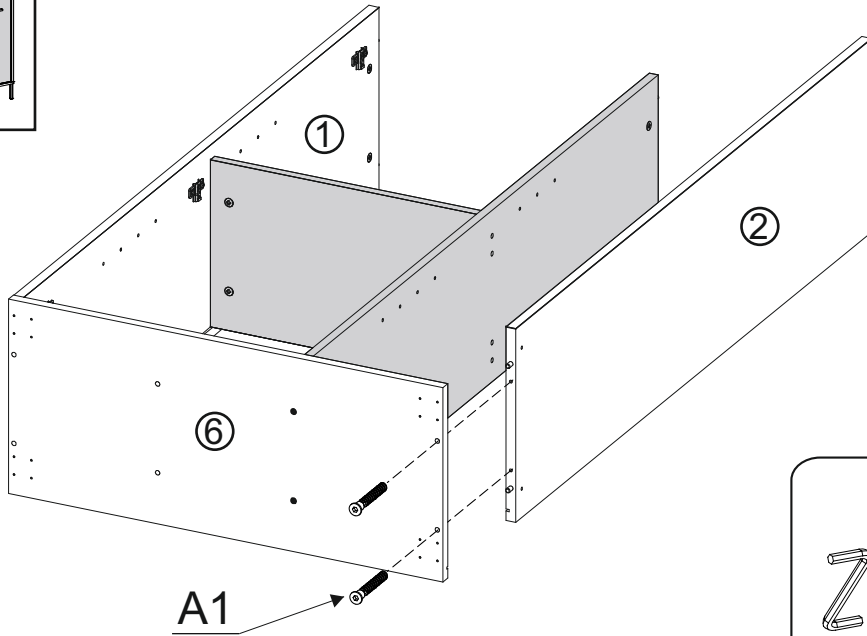
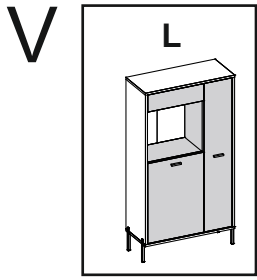
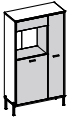

- A1**
ø7x50 x2
- W2**
x1

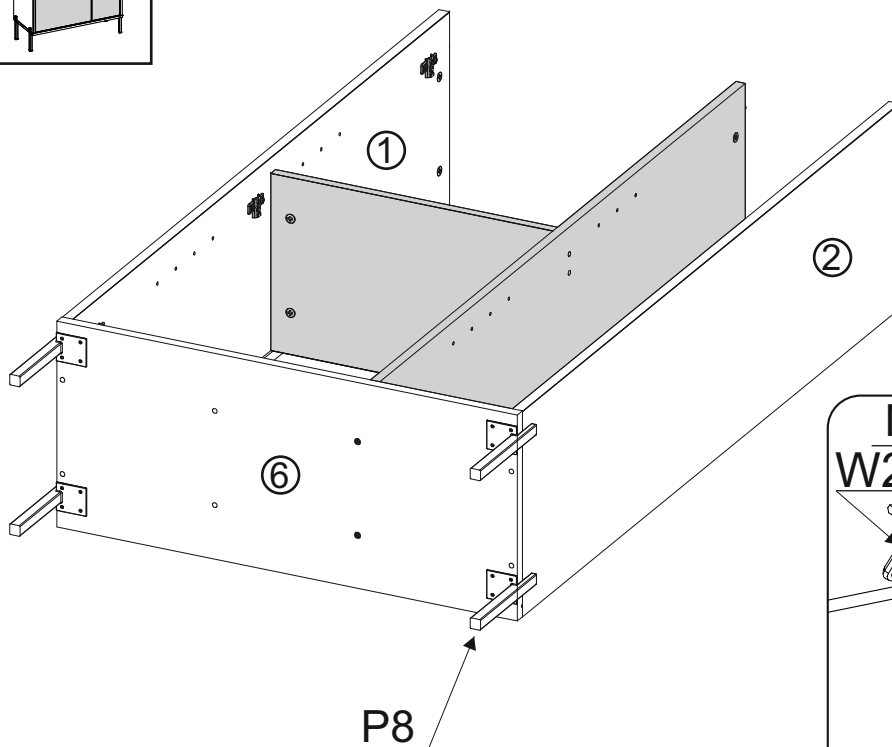
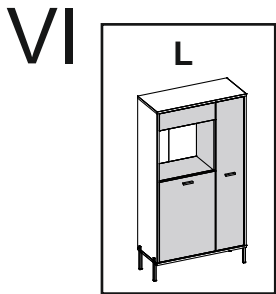
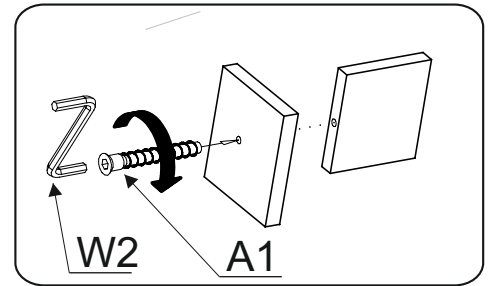

- G49**
4x16 x16
- N4**
x4
- P8**
x4
- W2**
x1

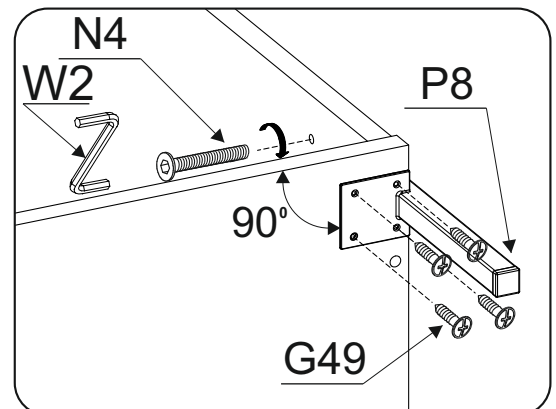

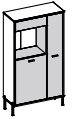

VII

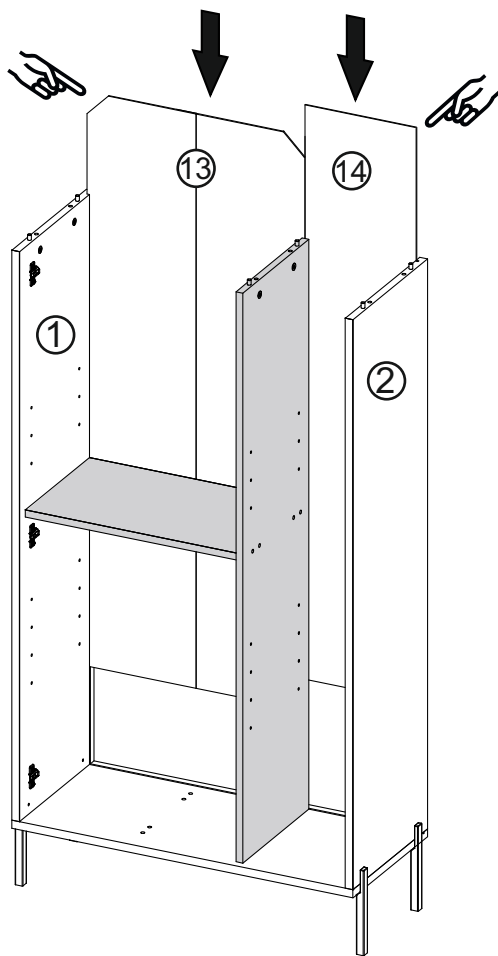
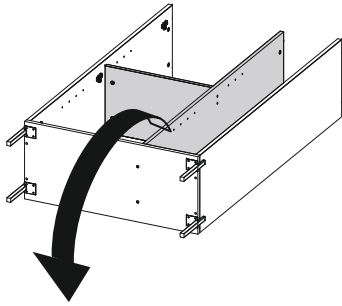
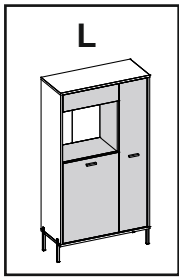

VIII

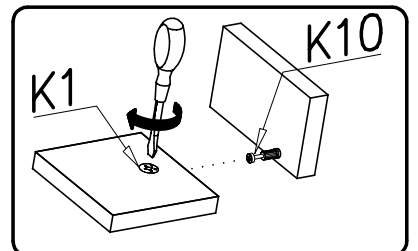
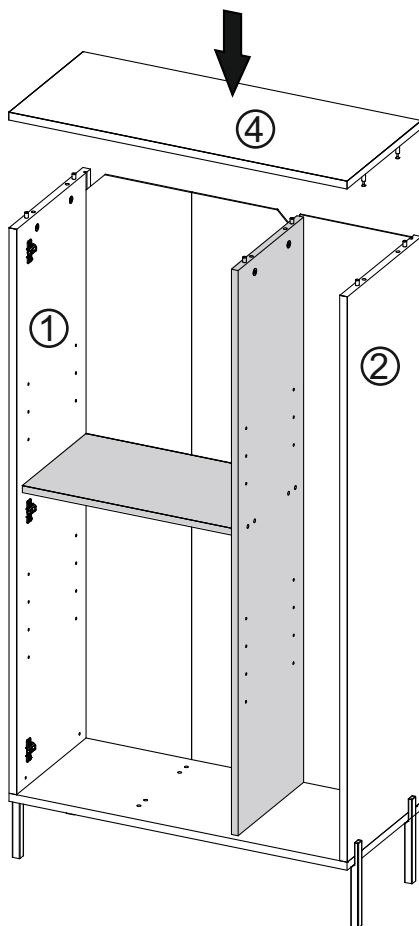
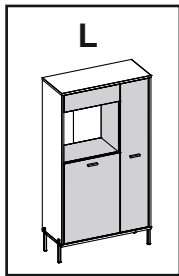

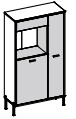

IX

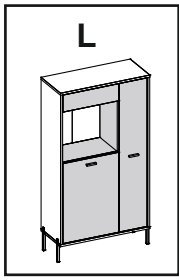

I1

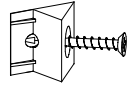

x14

G50



3x20

x12

Z6

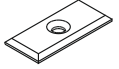

x8

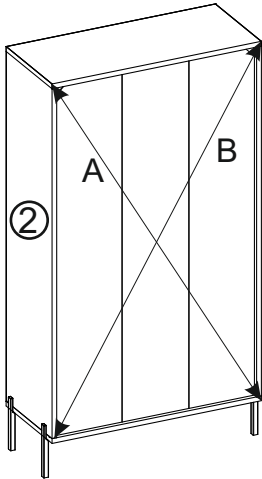

A=B

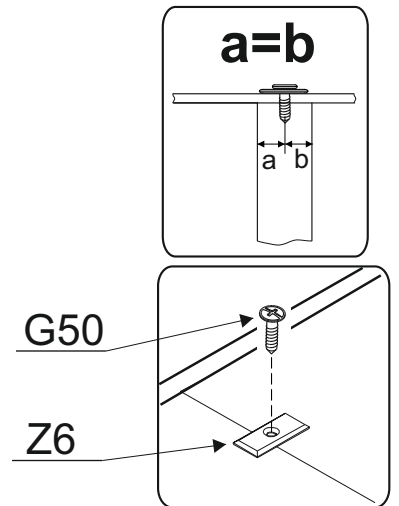
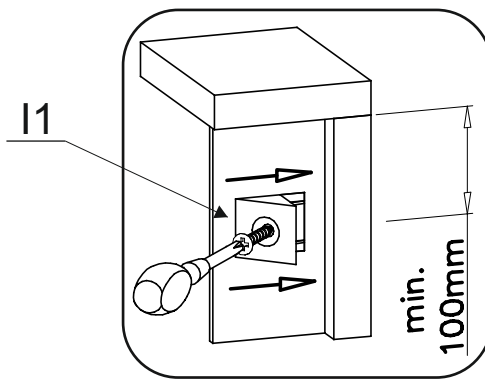
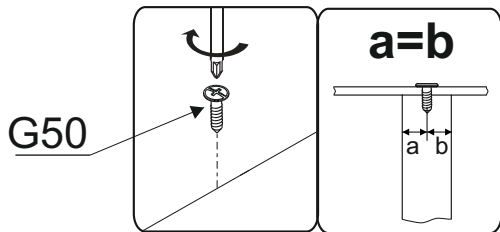
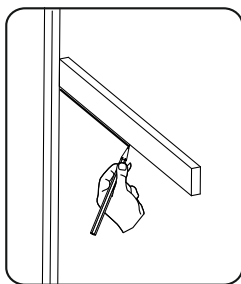
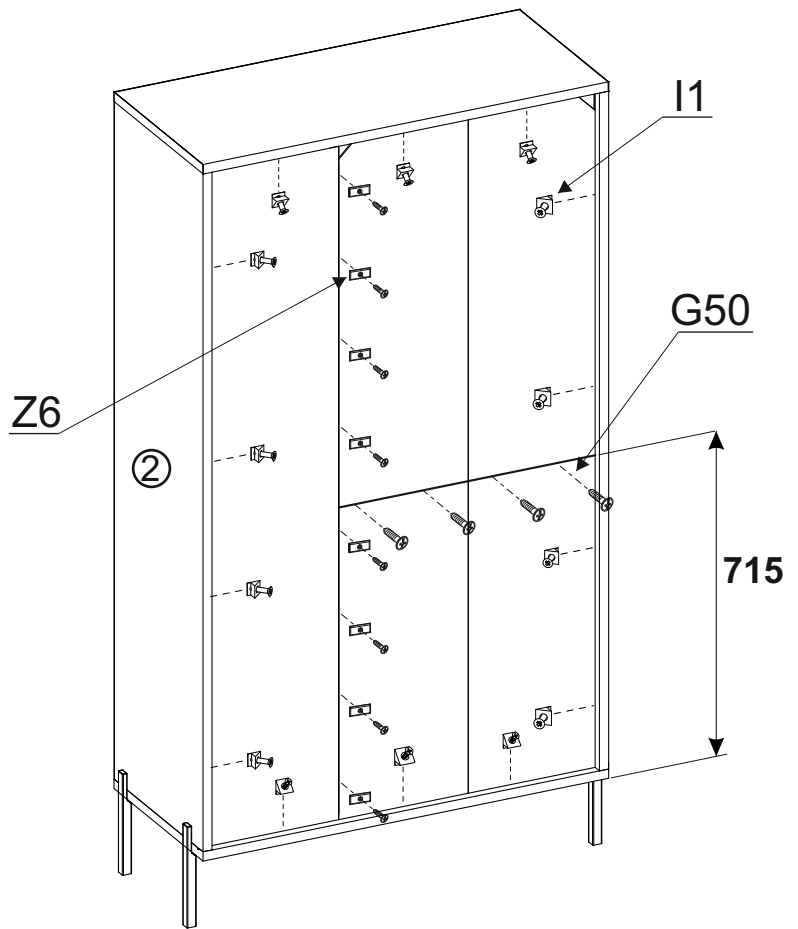

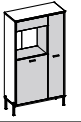

X

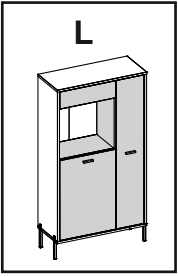

G34

3,5x16



x2

M11

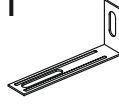

x2

I8



x4

I7



x6

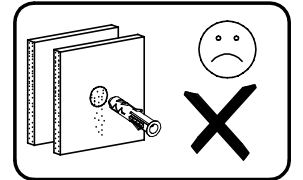
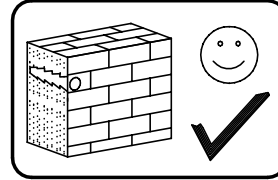
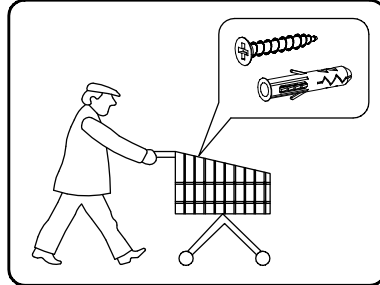

M11

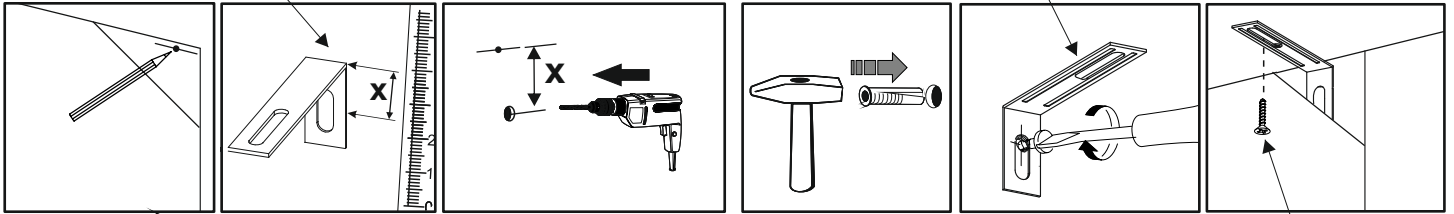

M11

G34

I8

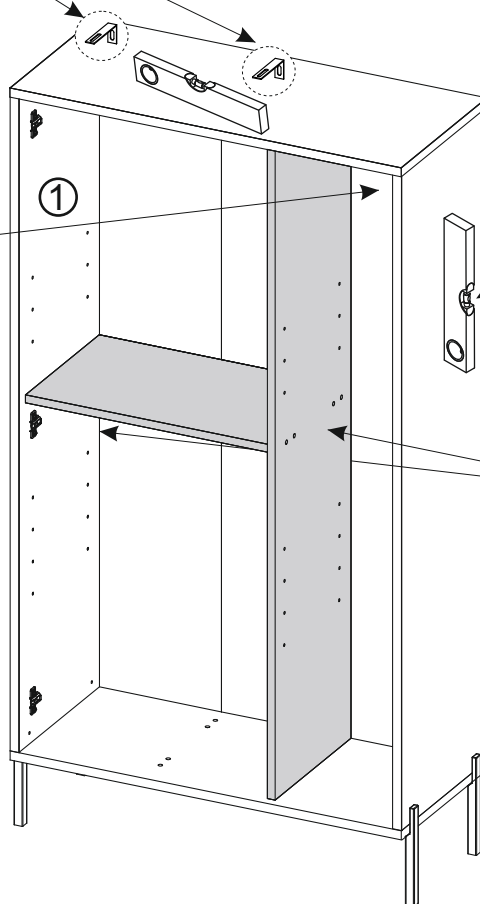
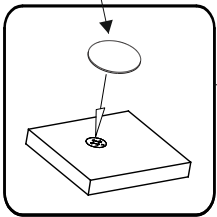



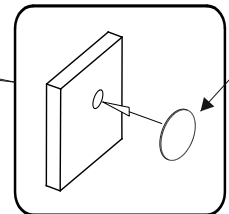

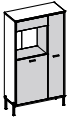
I7



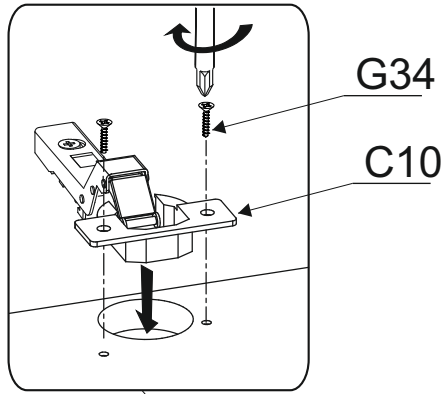
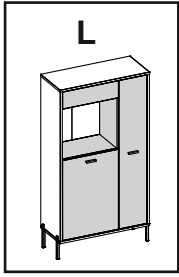

XII

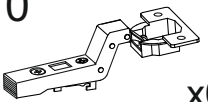

F20		x6	C10		x6
G49		x6	G34		x12
4x16			3,5x16		

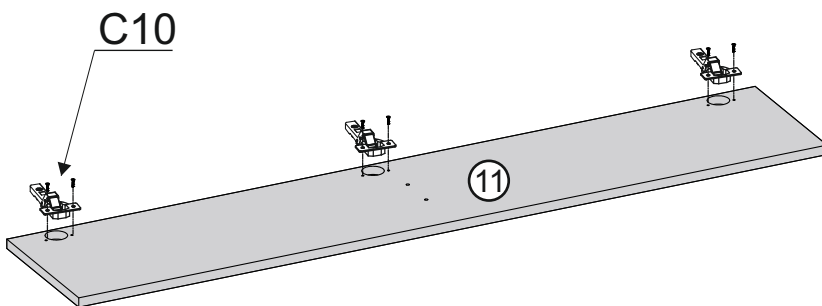
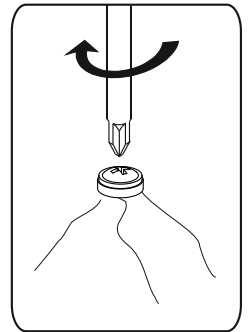
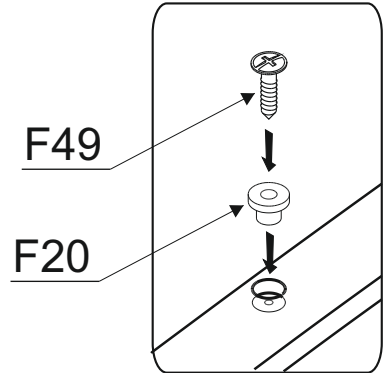
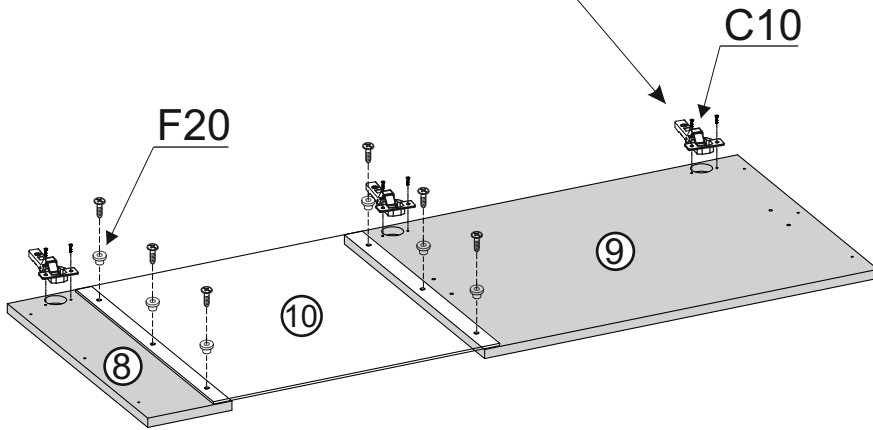

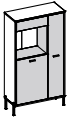

XIII

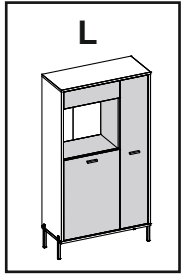

F2

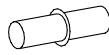

x12

U8

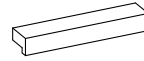

x2

N2

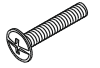

4x22

x4

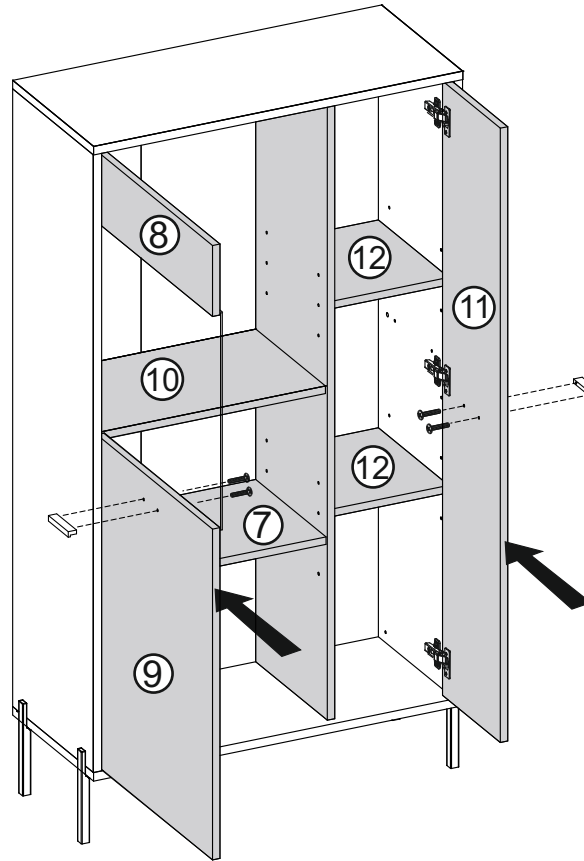
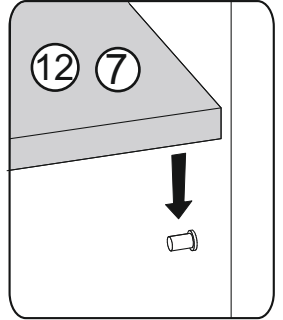
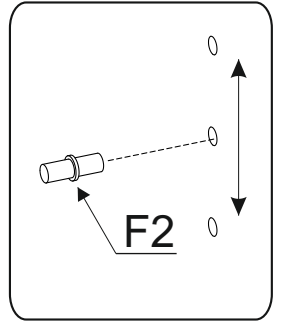
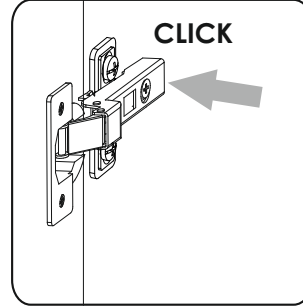
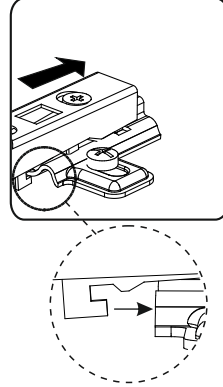
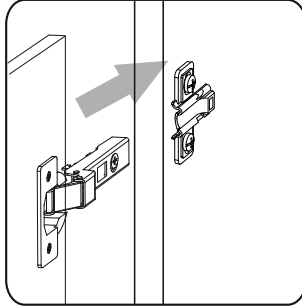

U8

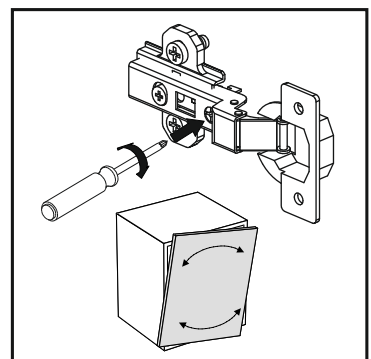
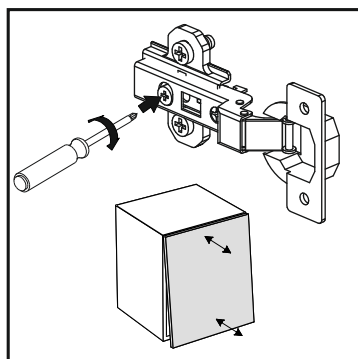
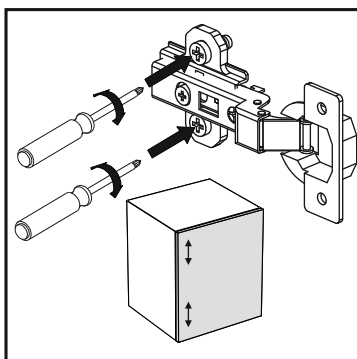
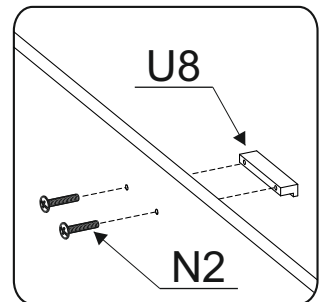
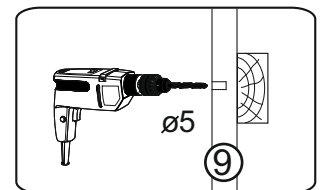

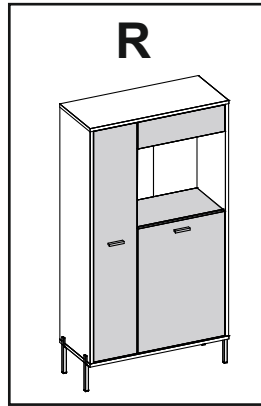

13/23 - 21/23

I

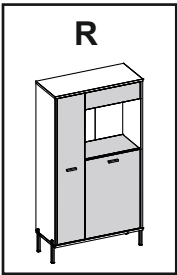

B1

∅8x35



x8

K1



x4

D6

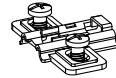

x6

K10

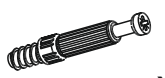

x2

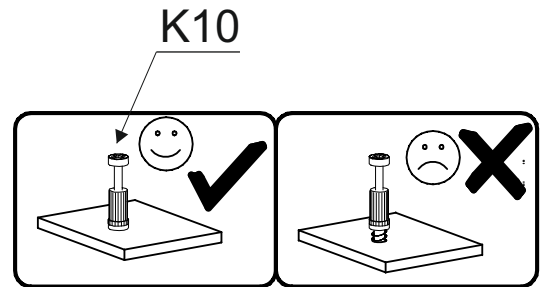
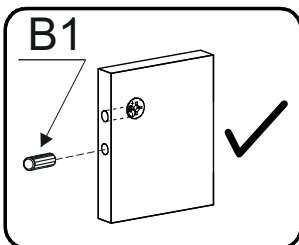
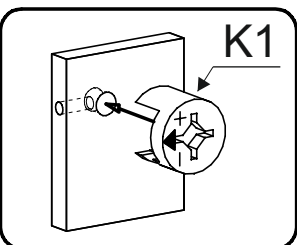
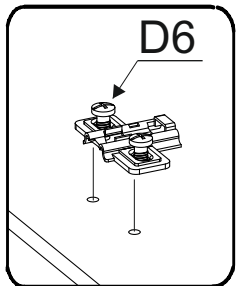
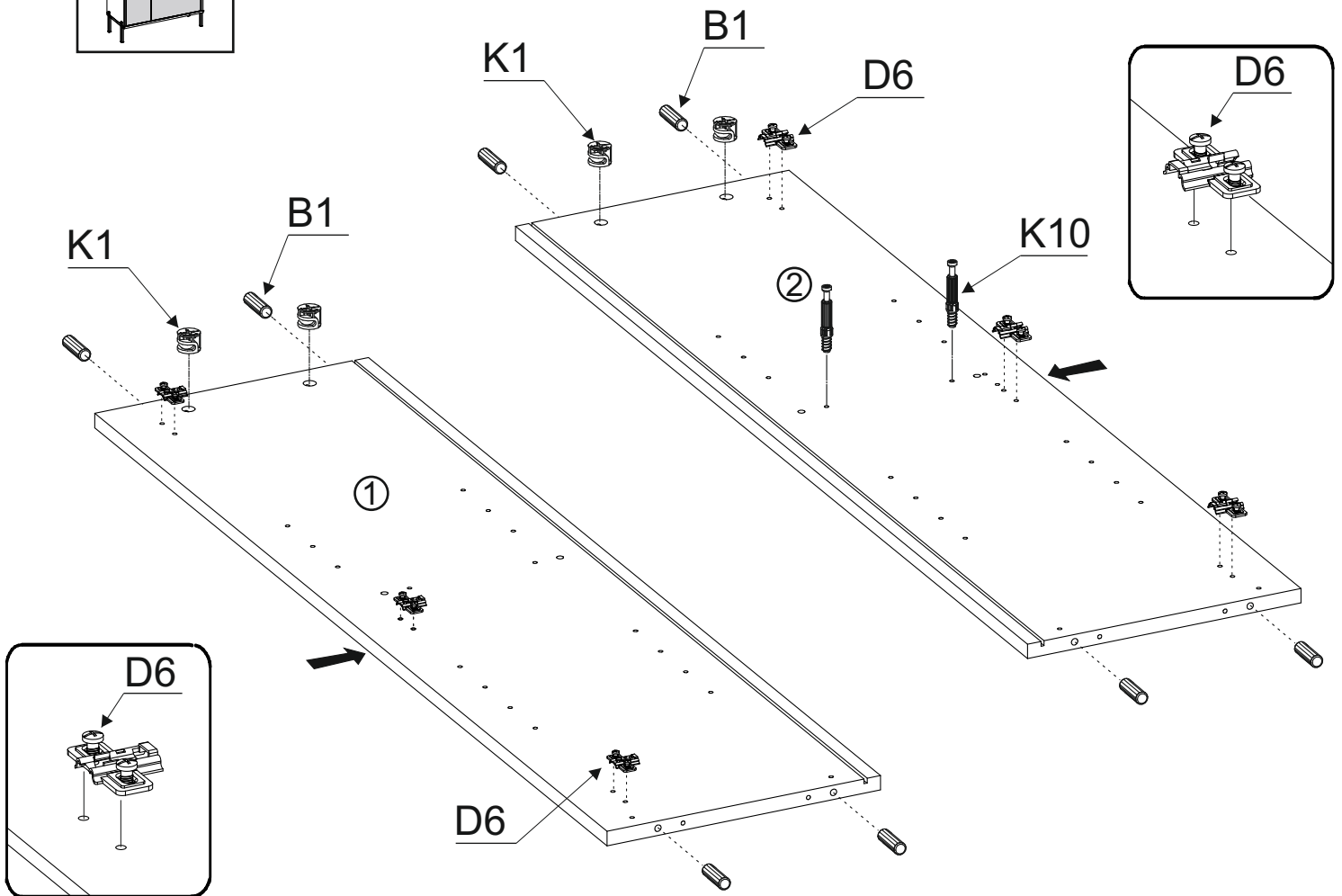

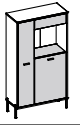

II

R

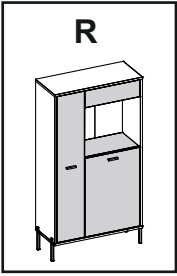

B1

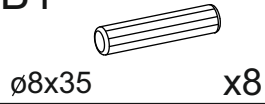

K1



x4

K10



x6

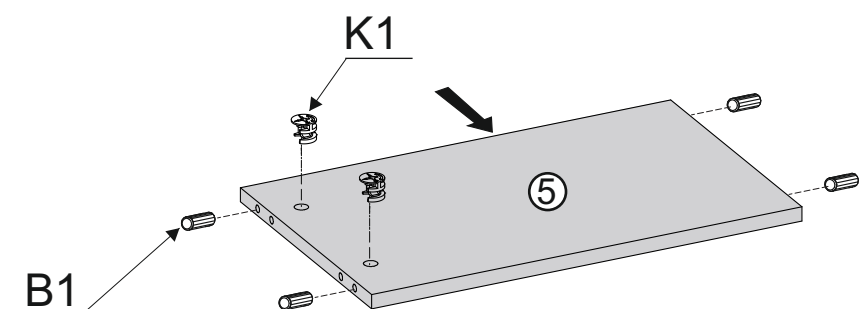
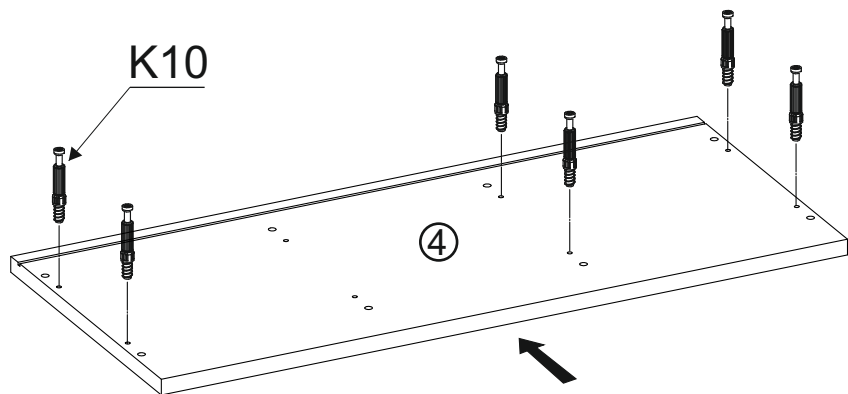
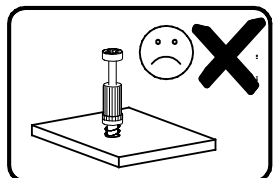
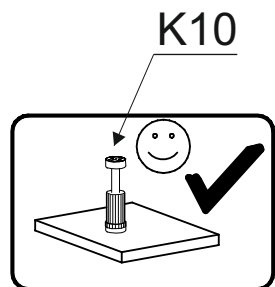
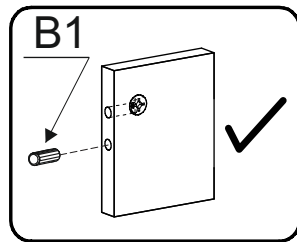
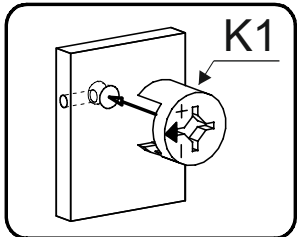
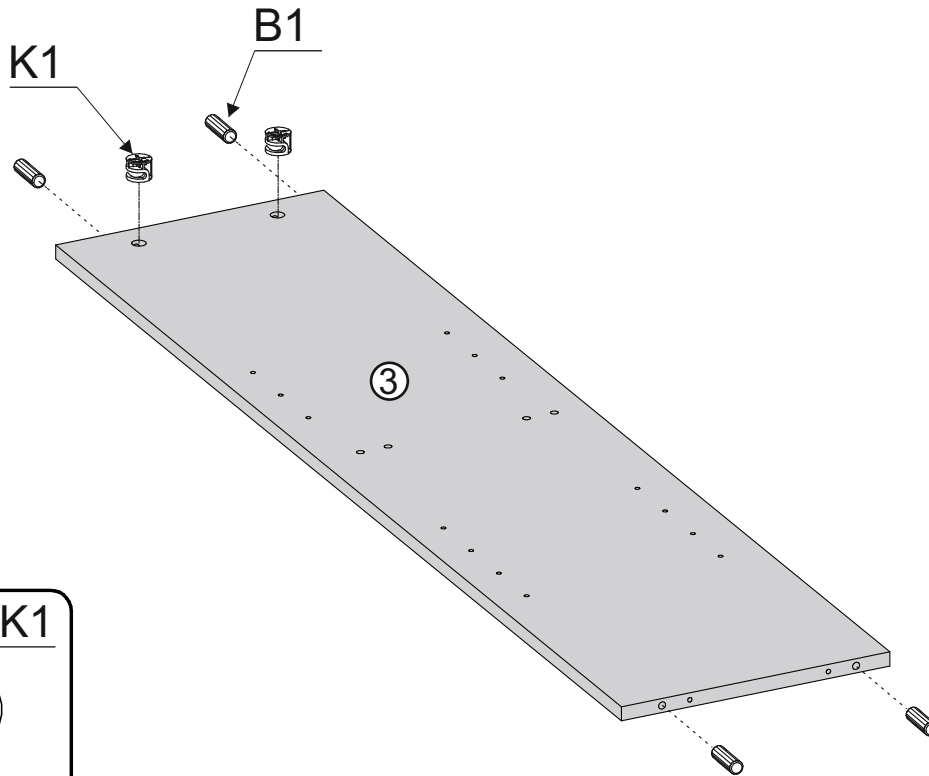

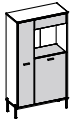

III

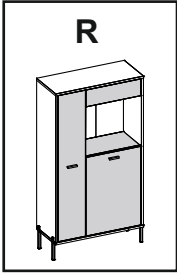

A1



ø7x50

x2

W2

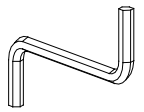

x1

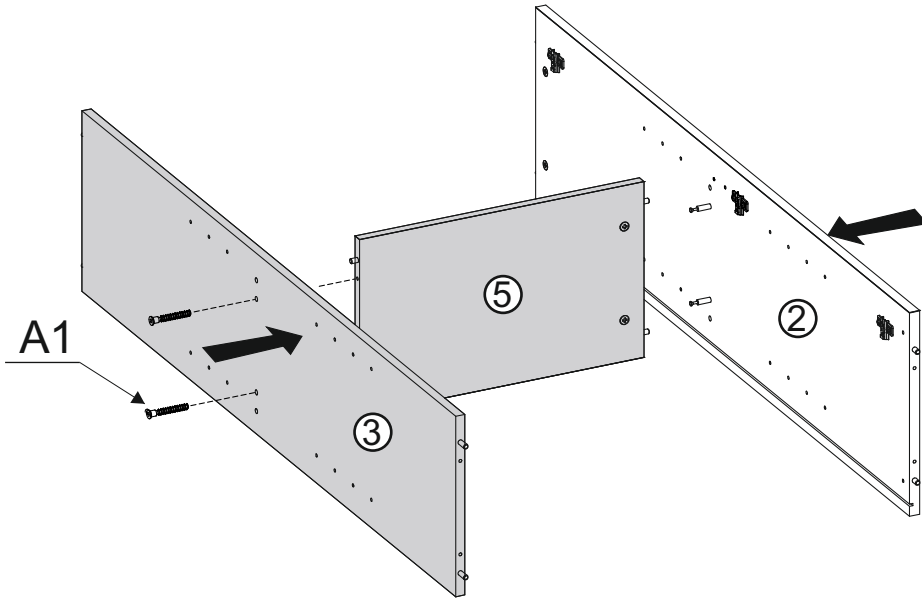
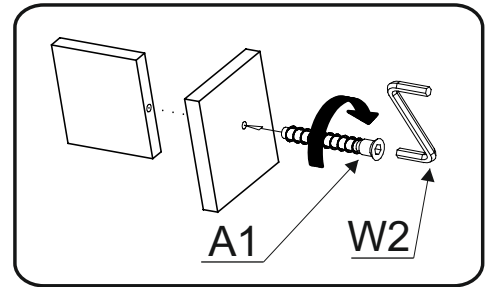
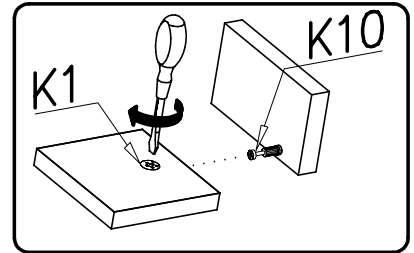

IV

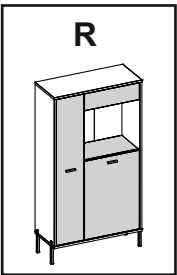

A1



ø7x50

x4

W2

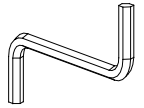

x1

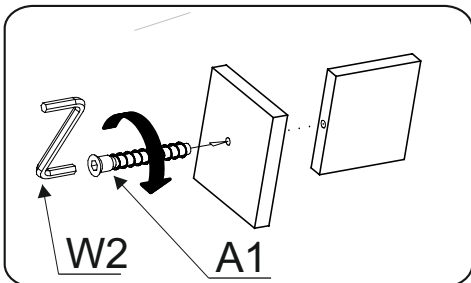
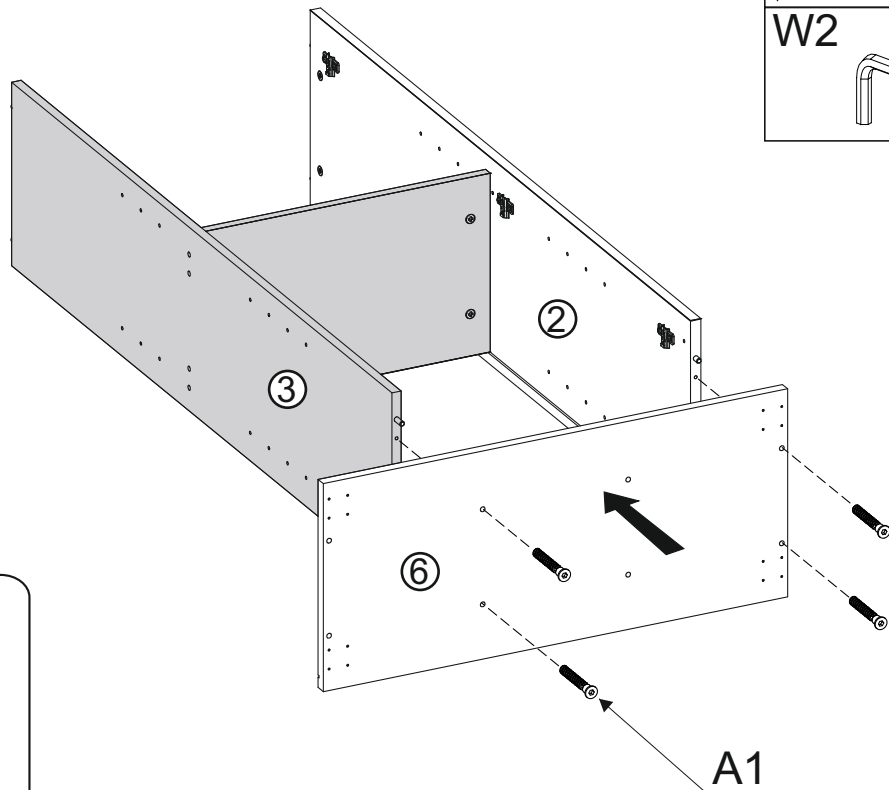

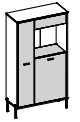

V

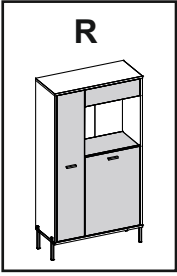

A1



ø7x50

x2

W2

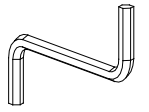

x1

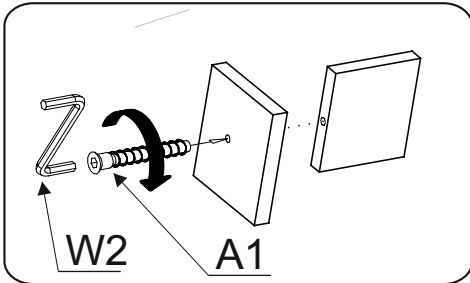
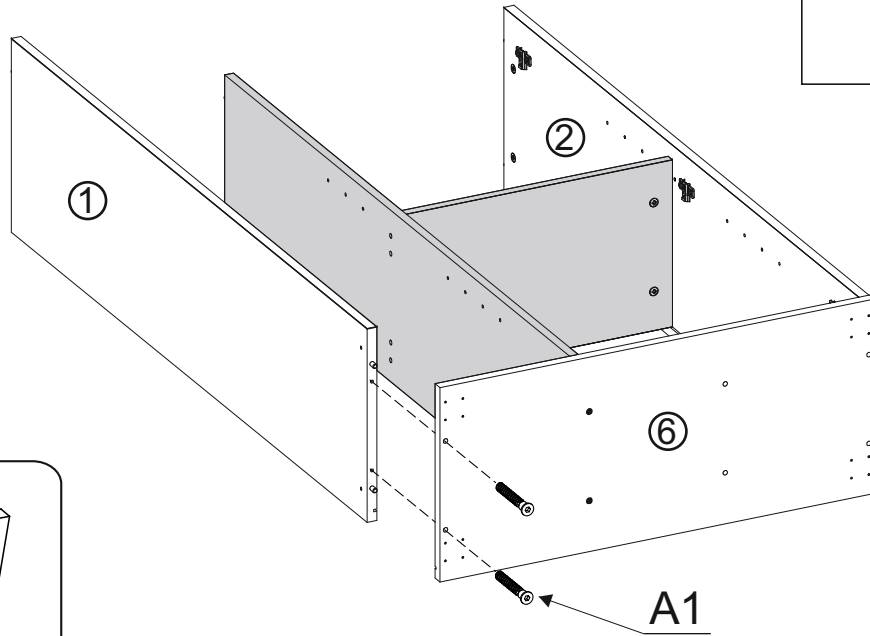

VI

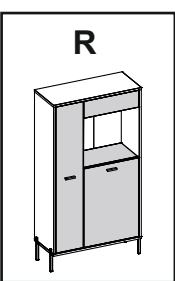

W2

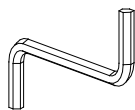

x1

G49



4x16

x16

N4



x4

P8

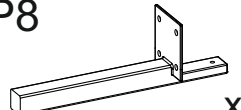

x4

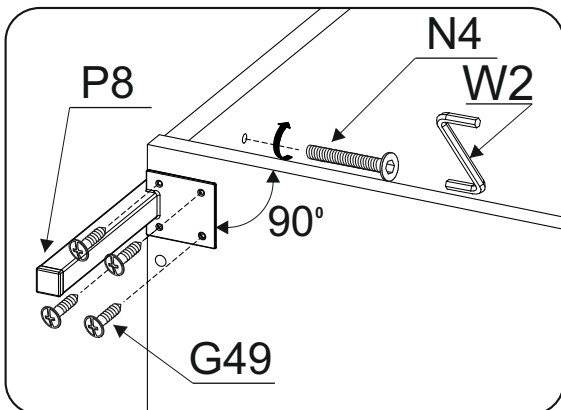
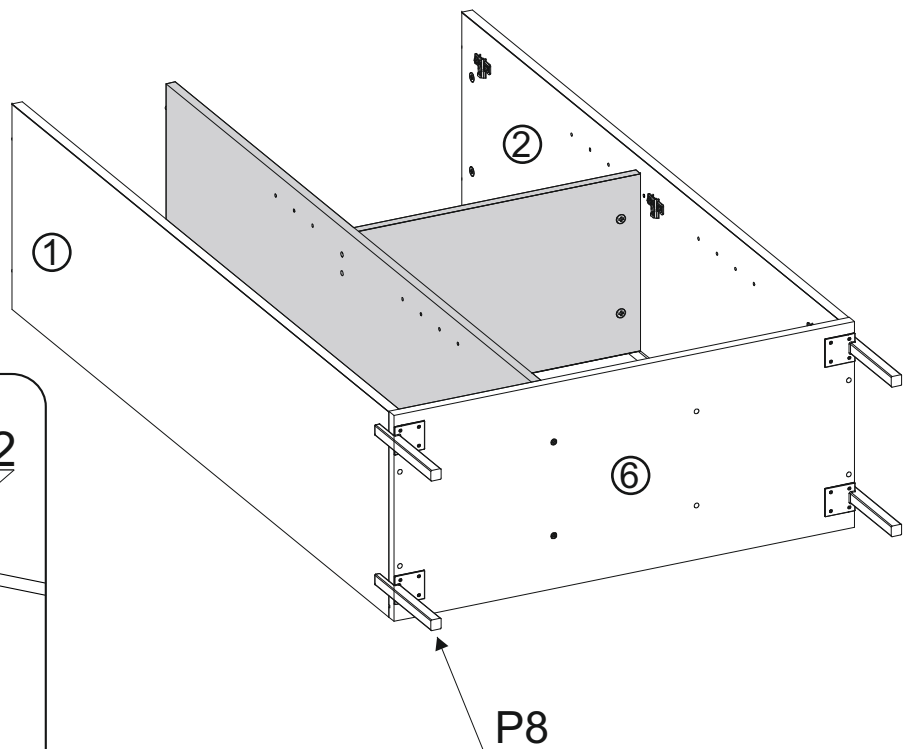

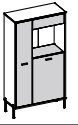

VII

R

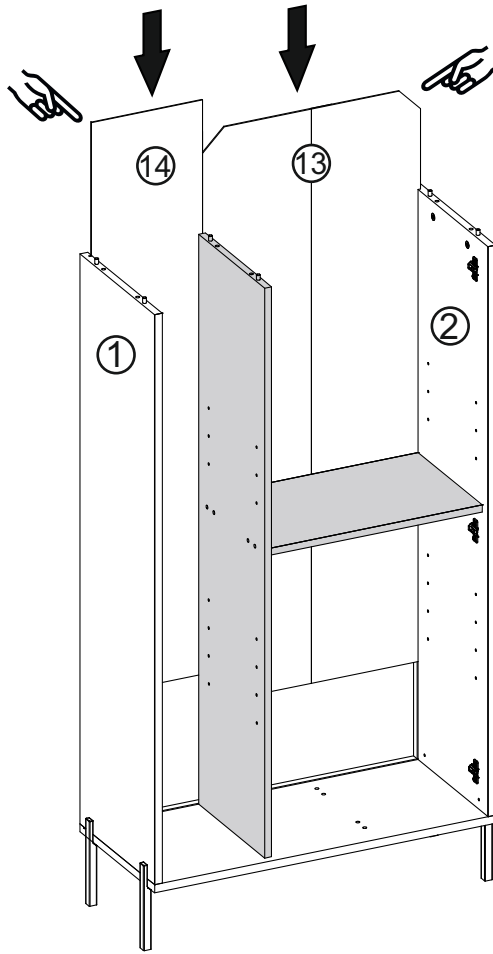
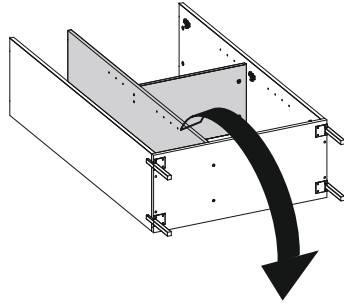
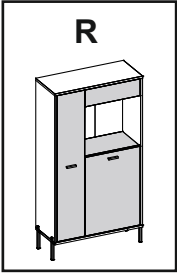

VIII

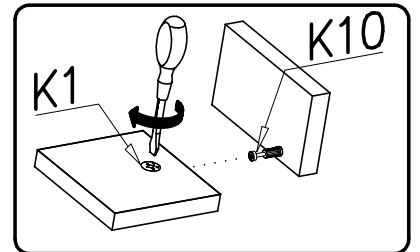
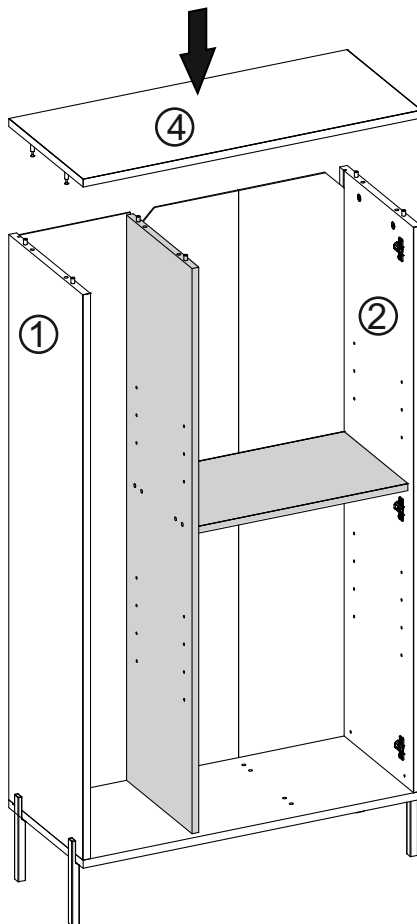
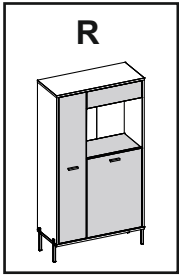

R

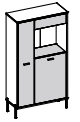

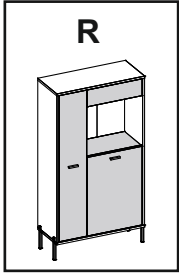

IX

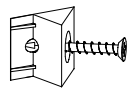

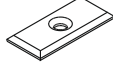
<p>I1</p>  <p>x14</p>	<p>G50</p>  <p>3x20</p> <p>x12</p>	<p>Z6</p>  <p>x8</p>
--	---	---

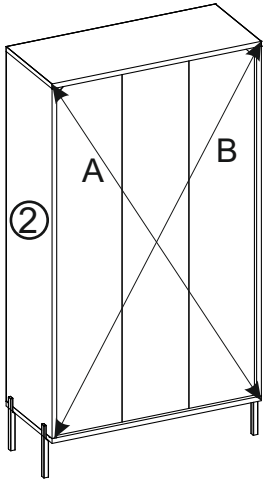

A=B

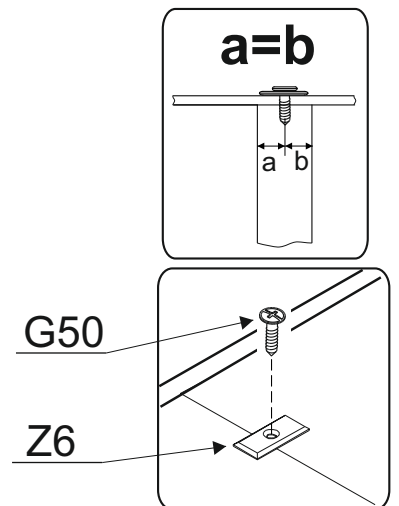
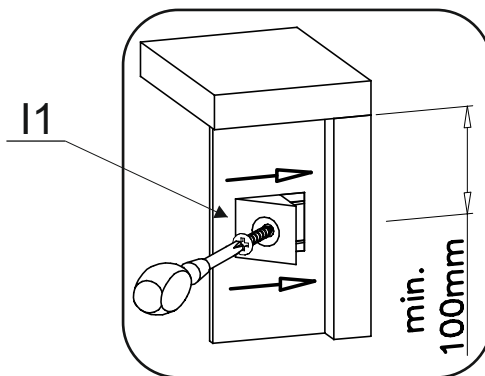
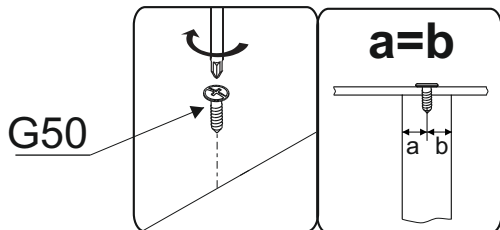
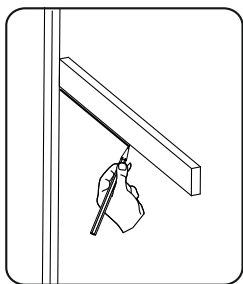
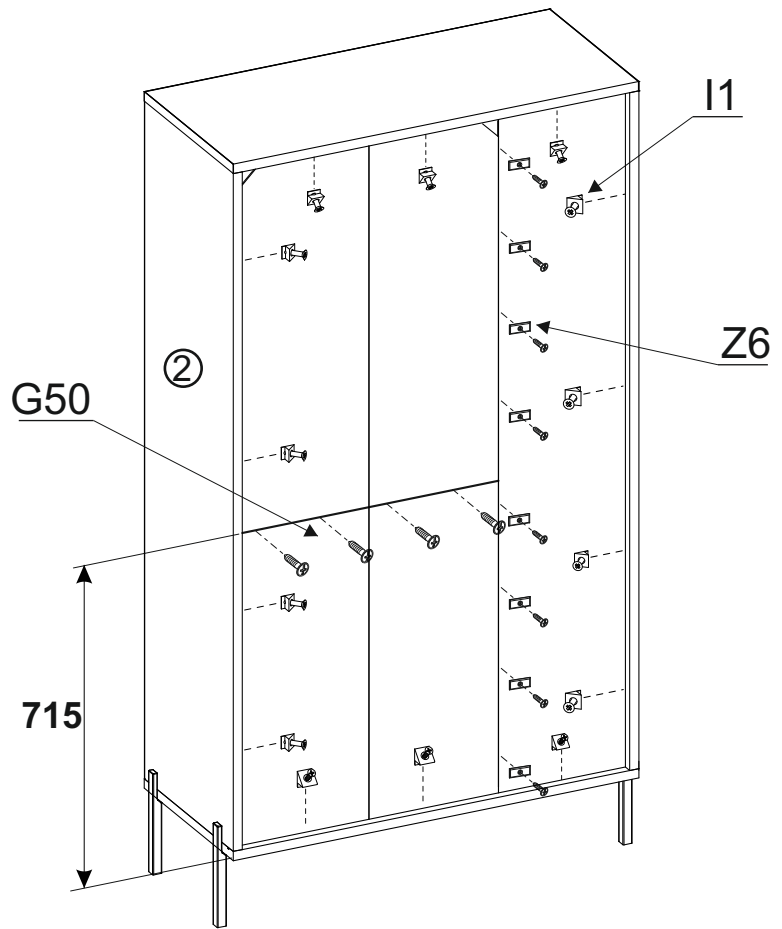

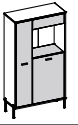

X

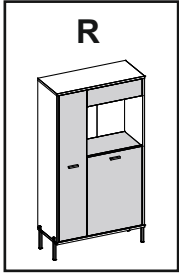

I8		G34		M11		I7	
	x4	3,5x16	x2		x2		x6

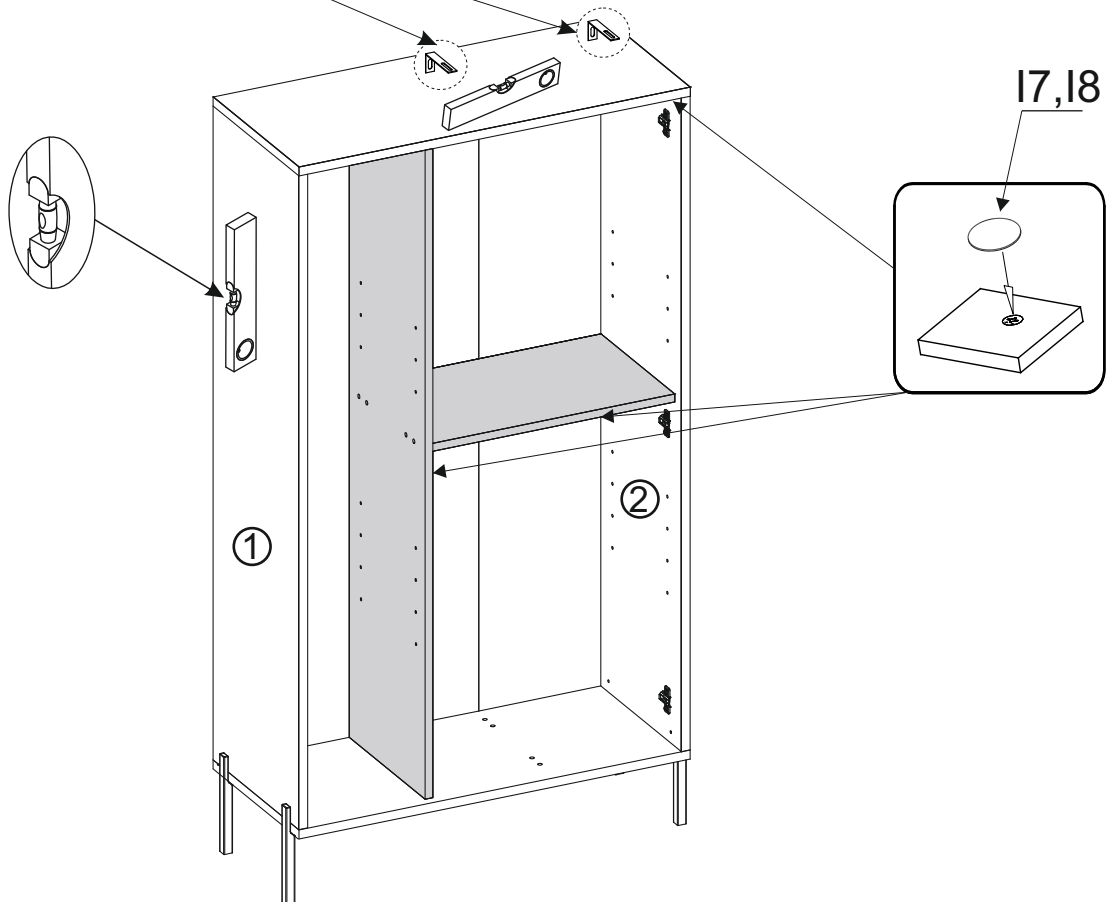
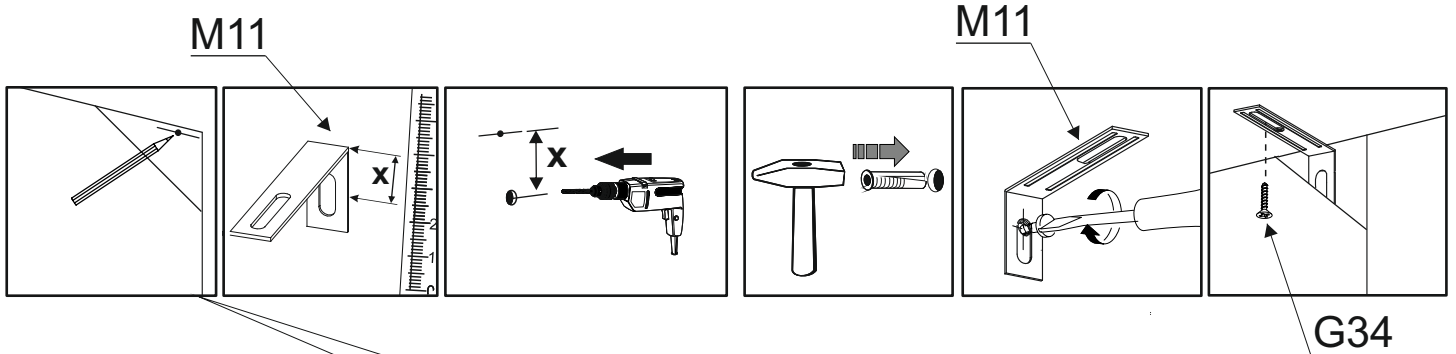
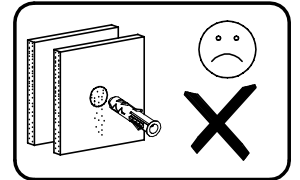
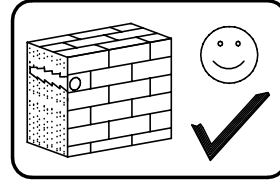
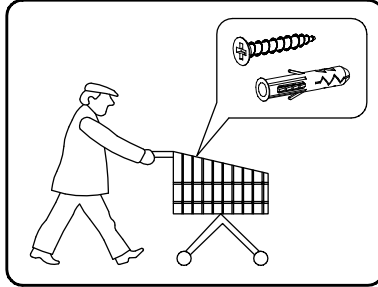

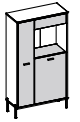

XII

R

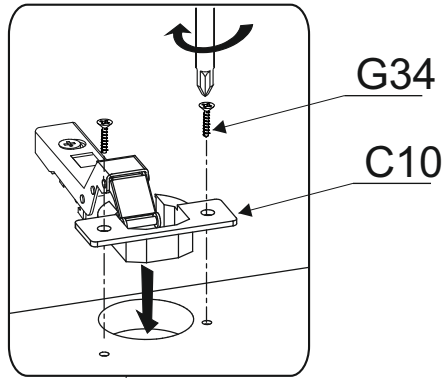
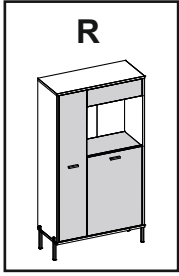

F20



x6

C10

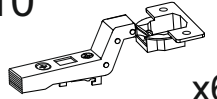

x6

G49



4x16

x6

G34



3,5x16

x12

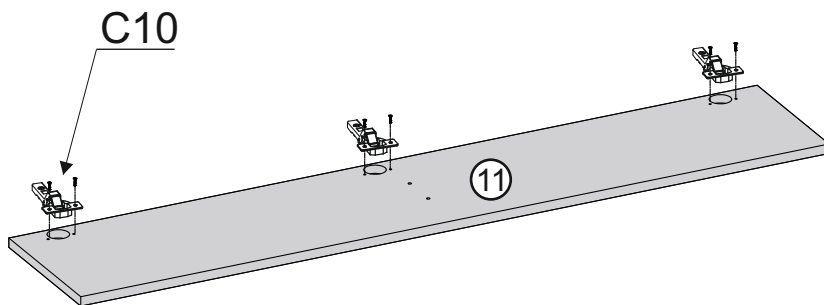
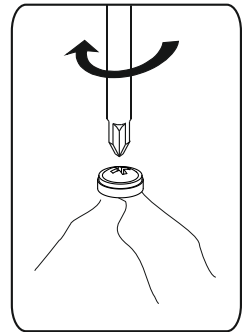
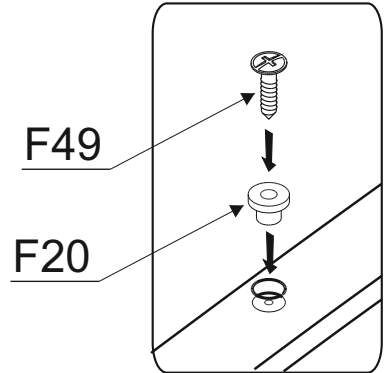
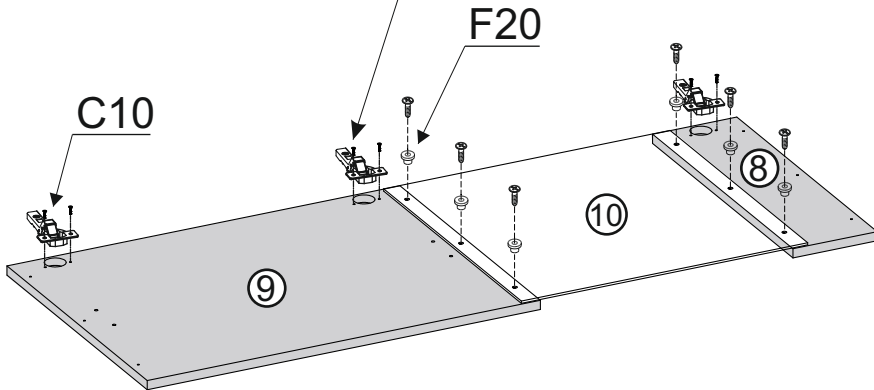



XIII

F2

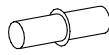

x12

U8

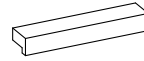

x2

N2



4x22

x4

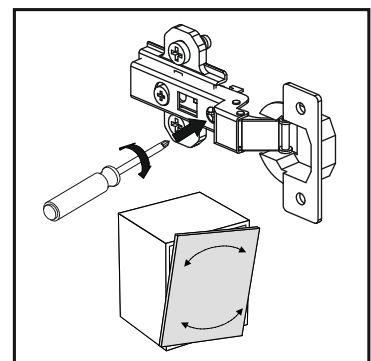
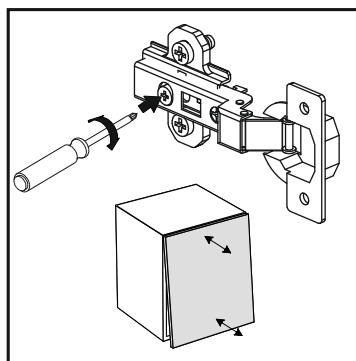
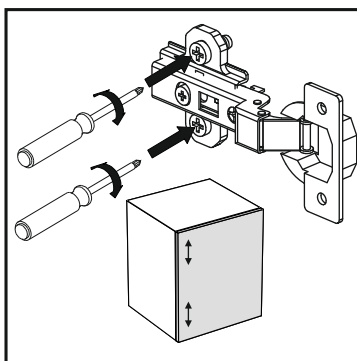
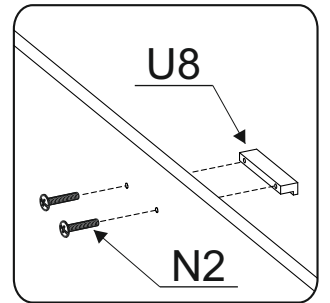
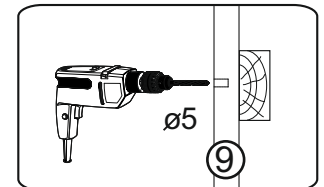
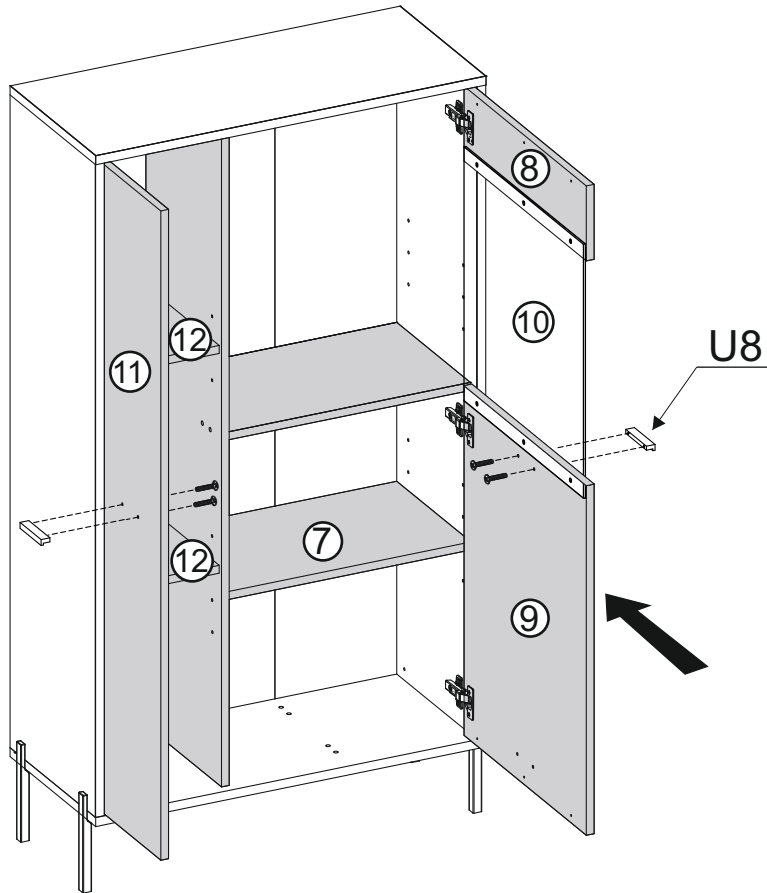
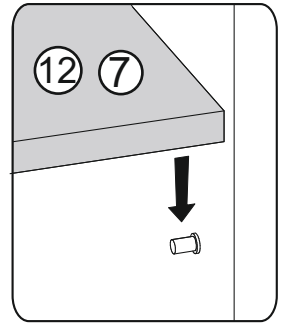
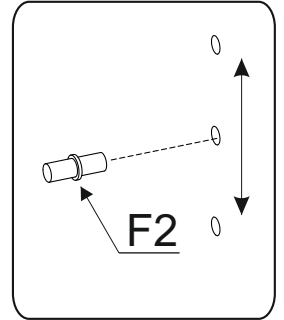
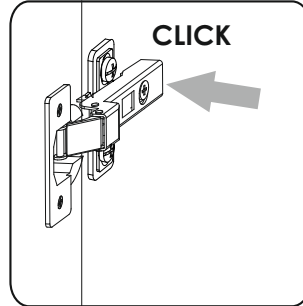
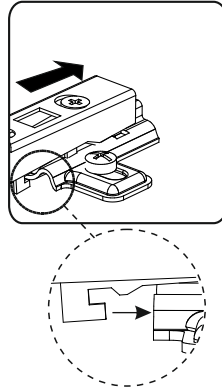
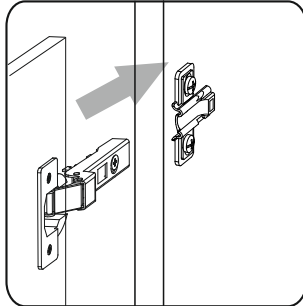
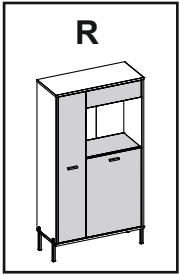

Name • Nom • Nome • Naam • Nazwa • Imięno
• Názov • Név • Denumire • Isim • Имявание

Nr • No • N° • Номер • Č • Sz

Typ • Type • Tip • Típus • Tipo • Tun

FREDERICIA

— —

21

D Unser Direktservice für Beschlagteile

Sollte Ihnen ein Beschlagteil fehlen, können Sie diese Servicekarte direkt an die untenstehende Adresse mailen. Wir können allerdings nur Beschlagteile auf diesem Wege verschicken. Sollten Sie eine andere Beanstandung an Ihrem Möbelstück haben, so wenden Sie sich bitte direkt an Ihr Möbelhaus.

GB Our direct order service for fitting

If a fitting part is missing, you can e-mail this service card directly to the address below. However, we can only send fitting parts in this way. If you have any other cause for complaint concerning your item of furniture, please contact your furniture store directly.

CZ Naše přímé služby pro kování

Chybí-li vám nějaký díl z kování, můžete tuto servisní kartu odeslat e-mailem přímo na níže uvedenou adresu. Touto cestou však můžeme rozesílat jen díly kování. Pokud byste reklamovali jiný díl nábytku, obraťte se přímo na svého prodejce nábytku.

F Bien etudier la notice de montage

S'il vous manque une ferrure, veuillez envoyer directement la présente carte service à l'adresse e-mail indiquée ci-dessous. Cependant, ceci nous permet uniquement d'envoyer des ferrures. Pour tout autre type de réclamation concernant votre meuble, veuillez contacter directement votre magasin d'ameublement.

I Il nostro servizio diretto per l'ordine della ferramenta

Qualora Vi dovesse mancare un pezzo di fissaggio, allora Vi preghiamo di inviare questa carta di servizio immediatamente all'indirizzo sottostante. Possiamo inviare i pezzi di fissaggio solamente per mezzo di questo procedimento. Qualora dovete avere qualche altra reclamazione in merito al mobile, allora Vi preghiamo di rivolgerVi direttamente al Vostro Negozio di mobili.

BG Нашата директна услуга за обков

Ако липсват части от комплекта, попълнете настоящата сервисна карта и ни я изпратете на e-mail адреса, посочен по-долу. По този начин можем да доставяме само липсващи елементи от обкова. Ако установите други дефекти по мебелите, Ви съветваме да се обърнете към мебелната къща/магазин, от който сте закупили столката.

NL Onze directservice voor losse onderdelen

Wanneer er een onderdeel ontbreekt, kunt u deze servicekaart direct aan onderstaand e-mailadres sturen. Wij kunnen langs deze weg echter alleen beslagdelen versturen. Mocht u een ander probleem aan uw meubel hebben, verzoeken wij u contact op te nemen met uw meubeldealer.

PL Nasz bezpośredni serwis części montażowych

Jeżeli brakuje części koniecznych do montażu, prosimy o przesłanie nam niniejszej karty serwisowej na niżej podany adres e-mailowy. W ten sposób możemy przesyłać Państwu tylko brakujące części. W przypadku innych reklamacji dotyczących mebla, prosimy zgłosić się do salonu meblowego, w którym został dokonany zakup.

HR Servis za okove

U slučaju da nedostaje neki od dijelova molimo vas da na dolje navedenu mail adresu pošaljete ovaj servisni obrazac. Na ovaj način mogu se dostaviti samo okovi. U slučaju da imate dodatne prigovore vezane uz komad namještaja molimo vas da se obratite izravno trgovini namještaja gdje je isti kupljen.

HU Direktszolgáltatunk vasalatok esetén

Ha hiányzik egy vasalat, ezt a kártyát közvetlenül elküldheti az alább található címre. Azonban csakis vasalatokat tudunk így küldeni. Amennyiben másfajta reklamáció áll fenn börtordarabját illetően, forduljon közvetlenül a bútornához.

SK Náš priamy servis pre časti kovania

Ak by Vám chýbala nejaká časť kovania, môžete poslať túto servisnú kartu poslať e-mailom na nižšie uvedenú adresu. Diely kovania vieme poslať iba týmto spôsobom. Ak by ste mali inú reklamáciu ohľadom Vášho nábytku, obráťte sa priamo na Vašu predajňu nábytku.

SLO Naše direktne uslužne storitve za okovje

Če vam manjka kakšno okovje, lahko to servisno kartico pošljete po e-pošti direktno na spodnji naslov. Po tej poti vam lahko pošljemo samo okovje. Če želite reklamirati kakšen drug del pohištva, se obrnite neposredno na vašo trgovino pohištva.

RO Service-ul nostru direct pentru feronerie

În cazul în care vă lipsește o piesă de feronerie puteți să trimiteți direct acest card de service prin e-mail la adresa de mai jos. Noi nu putem expedia piese de feronerie decât pe această cale. Dacă aveți o altă reclamație referitoare la piesa de mobilier, atunci vă rugăm să vă adresați direct la magazinul dvs. de mobilă.

RUS Наш прямой сервис для поставок фурнитуры

Если окажется, что Вам не хватает того или иного элемента фурнитуры, Вы можете отправить сервисную карту по факсу непосредственно на нижеприведенный адрес электронной почты. Однако, таким образом мы можем пересылать лишь фурнитуру. Если же у Вас возникнут иные претензии относительно приобретенной мебели, пожалуйста, обращайтесь непосредственно в организацию, осуществившую продажу.

S Vår direktservice för beslagsdelar

Om du saknar en beslagsdel kan du skicka detta servicekort direkt till e-postadressen som anges nedan. Tänk på att detta är den enda möjligheten att skicka beslagsdelar till dig. Om du vill reklamera din möbel av en annan anledning måste du kontakta ditt möbelhus direkt.

ES Nuestro servicio directo para accesorios

Si le falta algún accesorio, puede enviar esta tarjeta de servicio directamente a la siguiente dirección. No obstante, por este método solo podemos enviar accesorios. Si tiene alguna otra objeción sobre su mueble, consulte directamente con su mueblería.

TR Donatılar için doğrudan servisimiz

Bir donatınız eksikse bu servis kartını doğrudan aşağıda bulunan adrese doğrudan mail yazabilirsiniz. Sadece bu yolla donatıları gönderebiliriz. Mobilyanızda başka şikayetleriniz varsa lütfen doğrudan mobilya satıcınıza danışın.

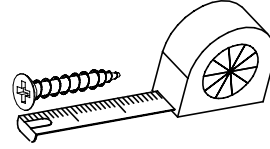

B1 Ø8x35 X...	A1 Ø7x50 X...	W2 X...
K1 15x12 X...	K10 X...	G34 3,5x16 X...
G50 3x20 X...	F20 X...	I7 X...
M11 X...	I1 X...	Z6 X...
C10 X...	P8 X...	N4 6x25 X...
G49 4x16 X...	U8 X...	N2 4x22 X...
F2 X...	I8 X...	

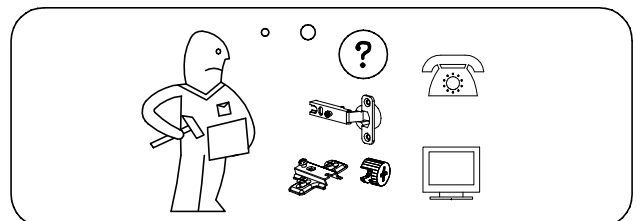
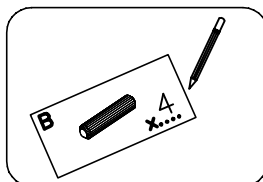

Name • Nom • Nome • Naam • Nazwa • Иméно
• Názov • Név • Denumire • Isim • Извание

FREDERICIA

Nr • No • N° • Номер • Č • Sz

Typ • Type • Tip • Típus • Tipo • Tun

21

Under Direktservice für Beschlagteile

Sollte Ihnen ein Beschlagteil fehlen, können Sie diese Servicekarte direkt an die untenstehende Adresse mailen. Wir können allerdings nur Beschlagteile auf diesem Wege verschicken. Sollten Sie eine andere Beanstandung an Ihrem Möbelstück haben, so wenden Sie sich bitte direkt an Ihr Möbelhaus.

Our direct order service for fitting

If a fitting part is missing, you can e-mail this service card directly to the address below. However, we can only send fitting parts in this way. If you have any other cause for complaint concerning your item of furniture, please contact your furniture store directly.

Naše přímé služby pro kování

Chybí-li vám nějaký díl z kování, můžete tuto servisní kartu odeslat e-mailem přímo na níže uvedenou adresu. Touto cestou však můžeme rozesílat jen díly kování. Pokud byste reklamovali jiný díl nábytku, obraťte se přímo na svého prodejce nábytku.

Bien etudier la notice de montage

S'il vous manque une ferrure, veuillez envoyer directement la présente carte service à l'adresse e-mail indiquée ci-dessous. Cependant, ceci nous permet uniquement d'envoyer des ferrures. Pour tout autre type de réclamation concernant votre meuble, veuillez contacter directement votre magasin d'ameublement.

Il nostro servizio diretto per l'ordine della ferramenta

Qualora Vi dovesse mancare un pezzo di fissaggio, allora Vi preghiamo di inviare questa carta di servizio immediatamente all'indirizzo sottostante. Possiamo inviare i pezzi di fissaggio solamente per mezzo di questo procedimento. Qualora dovete avere qualche altra reclamazione in merito al mobile, allora Vi preghiamo di rivolgerVi direttamente al Vostro Negozio di mobili.

Нашата директна услуга за обков

Ако липсват части от комплекта, попълнете настоящата сервисна карта и ни я изпратете на e-mail адреса, посочен по-долу. По този начин можем да доставяме само липсващи елементи от обкова. Ако установите други дефекти по мебелите, Ви съветваме да се обърнете към мебелната къща/магазин, от който сте закупили стоката.

Onze directservice voor losse onderdelen

Wanneer er een onderdeel ontbreekt, kunt u deze servicekaart direct aan onderstaand e-mailadres sturen. Wij kunnen langs deze weg echter alleen beslagdelen versturen. Mocht u een ander probleem aan uw meubel hebben, verzoeken wij u contact op te nemen met uw meubeldealer.

Nasz bezpośredni serwis części montażowych

Jeżeli brakuje części koniecznych do montażu, prosimy o przesłanie nam niniejszej karty serwisowej na niżej podany adres e-mailowy. W ten sposób możemy przesłać Państwu tylko brakujące części. W przypadku innych reklamacji dotyczących mebla, prosimy zgłosić się do salonu meblowego, w którym został dokonany zakup.

Servis za okove

U slučaju da nedostaje neki od dijelova molimo vas da na dolje navedenu mail adresu pošaljete ovaj servisni obrazac. Na ovaj način mogu se dostaviti samo okovi. U slučaju da imate dodatne prigovore vezane uz komad namještaja molimo vas da se obratite izravno trgovini namještaja gdje je isti kupljen.

Direktszolgálatunk vasalatok esetén

Ha hiányzik egy vasalat, ezt a kártyát közvetlenül elküldheti az alább található címre. Azonban csakis vasalatokat tudunk így küldeni. Amennyiben másfajta reklamáció áll fenn bútordarabját illetően, forduljon közvetlenül a bútortházhoz.

Náš priamy servis pre časti kovania

Ak by Vám chýbala nejaká časť kovania, môžete poslať túto servisnú kartu poslať e-mailom na nižšie uvedenú adresu. Diely kovania vieme poslať iba týmto spôsobom. Ak by ste mali inú reklamáciu ohľadom Vášho nábytku, obráťte sa priamo na Vašu predajňu nábytku.

Naše direktne uslužne storitve za okovje

Če vam manjka kakšno okovje, lahko to servisno kartico pošljete po e-pošti direktno na spodnji naslov. Po tej poti vam lahko pošljemo samo okovje. Če želite reklamirati kakšen drug del pohištva, se obrnite neposredno na vašo trgovino pohištva.

Service-ul nostru direct pentru feronerie

În cazul în care vă lipsește o piesă de feronerie puteți să trimiteți direct acest card de service prin e-mail la adresa de mai jos. Noi nu putem expedia piese de feronerie decât pe această cale. Dacă aveți o altă reclamație referitoare la piesa de mobilier, atunci vă rugăm să vă adresați direct la magazinul dvs. de mobilă.

Наш прямой сервис для поставок фурнитуры

Если окажется, что Вам не хватает того или иного элемента фурнитуры, Вы можете отправить сервисную карту по факсу непосредственно на нижеприведенный адрес электронной почты. Однако, таким образом мы можем пересылать лишь фурнитуру. Если же у Вас возникнут иные претензии относительно приобретенной мебели, пожалуйста, обращайтесь непосредственно в организацию, осуществившую продажу.

Vår direktservice för beslagsdelar

Om du saknar en beslagsdel kan du skicka detta servicekort direkt till e-postadressen som anges nedan. Tänk på att detta är den enda möjligheten att skicka beslagsdelar till dig. Om du vill reklamera din möbel av en annan anledning måste du kontakta ditt möbelhus direkt.

Nuestro servicio directo para accesorios

Si le falta algún accesorio, puede enviar esta tarjeta de servicio directamente a la siguiente dirección. No obstante, por este método solo podemos enviar accesorios. Si tiene alguna otra objeción sobre su mueble, consulte directamente con su mueblería.

Donatilar için doğrudan servisimiz

Bir donatınız eksikse bu servis kartını doğrudan aşağıda bulunan adrese doğrudan mail yazabilirsiniz. Sadece bu yolla donatıları gönderebiliriz. Mobilyanızda başka şikayetleriniz varsa lütfen doğrudan mobilya satıcınıza danışın.

nr	L[mm]	B[mm]	T[mm]	Menge	Colli
1	1307	349	18	1	1/2
2	1307	349	18	1	1/2
3	1307	309	16	1	2/2
4	798	350	18	1	1/2
5	497	302	16	1	2/2
6	798	350	18	1	1/2
7	497	304	16	1	2/2
8	500	150	16	1	2/2
9	700	500	16	1	2/2
10	510	490	4	1	2/2
11	1300	250	16	1	2/2
12	304	247	16	2	1/2
13	1317	510	3	1	1/2
14	1317	260	3	1	1/2

