

Montageanweisung / Installation instructions / Instruction de montage /Istruzioni di montaggio
montagehandleiding / Instrukja montażu / Montaj talimatlar / Osszeszerelési útmutató / Nàvod k montáži /
Nàvod na montáž / Instructiune de montaj / Инструкция по монтажу / Montaj talimatina / Monteringsanvisningar
Upute za montažu / Instrucciones de Montaje / Navodila za montažo

AMALFI

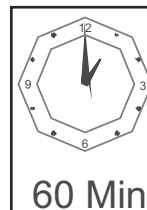
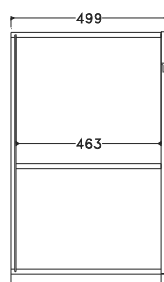
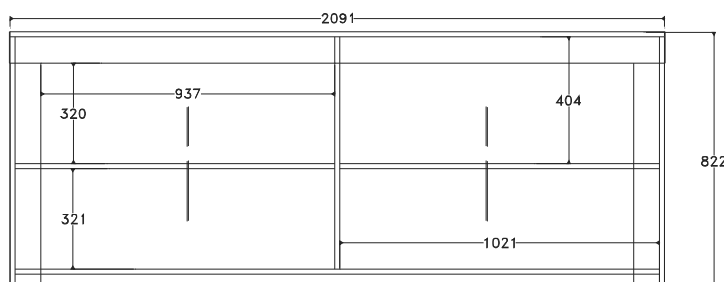
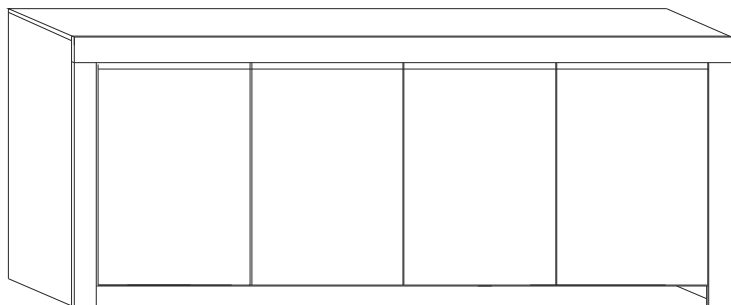
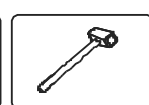
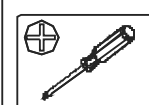
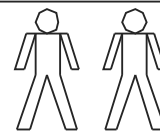

60 Min.

Total Kollis 3 Stuecke
Total colli 3 pieces
Numero total des colis:3
Colli totali 3
Totaal 3 colli's
Razem sztuk 3
Toplam parçalar 3
Celkem balíčky 3
Teljes csomag 3
Celkom balíčky 3
количество Всего 3
Total colete 3
Totalt antal kollin 3
Ukupno koleta 3
Bultos Totales 3
Skupno število paketov 3

D Bitte lesen Sie diese Montageanleitung gut durch, da wir für Fehler, die durch falsche Montage entstehen, keine Haftung übernehmen!

GB Please read these installation instructions through carefully as we cannot accept any liability for faults occurring as a result of incorrect installation!

CZ Přečtěte si prosím pozorně tento návod k montáži, aby jste předešli chybám vzniklých špatnou monzáži, za které neručíme!

F Veuillez lire attentivement cette notice de montage, car nous déclinons toute responsabilité en cas d'erreurs découlant d'un montage erroné !

I Prego leggere attentamente le istruzioni per il montaggio, poiché decliniamo qualsiasi responsabilità per difetti derivanti da un montaggio errato

S Läs monteringsanvisningarna noggrant. Vi avsäger oss allt ansvar för defekter som uppstår p.g.a. felaktig montering.

HR Pažljivo pročitajte upute za montažu, jer otklanjamo svaku odgovornost za pogreške nastale uslijed pogrešne montaže.

SLO Prosimo, da pozorno preberete navodila za montažo, saj zavračamo vsakršno odgovornost za napake, ki bi nastale zaradi napačne montaže.

NL Leest u alstublieft deze montagehandleiding goed door, voor fouten door verkeerde montage zijn wij niet verantwoordelijk.

PL Proszę uważnie zapoznać się z instrukcją montażu, ponieważ nie ponosimy odpowiedzialności za niewłaściwy montaż.

HU Kérjük, olvassa el figyelmesen ezt az összeszerelési útmutatót, mert a helytelen összeszerelésből a dódó hibákért nem vállalunk felelősséget!

SK Prosíme, dobre prečítajte si tento návod na montáž, pretože nepreberáme žiadne ručenie za chyby, ktoré vzniknú na základe chybnéj montáže!

RO Vă rugăm să citiți cu atenție aceste instrucțiuni de montaj deoarece nu preluăm garanția pentru defecte ce apar datorită unui montaj incorect!

RUS Пожалуйста, внимательно ознакомьтесь с данной инструкцией по монтажу, поскольку мы не несем ответственности за ошибки, причиной которых является неправильный монтаж.

TU İlkonce kullanma klavuzunu iyi okkuyun, yalnız montaj yapasanız bunun sorumlusu biz degiliz.

E Se rüega leer con atención las instrucciones de montaje debido a que declinamos cualquier responsabilidad por defectos derivados de un montaje erróneo

LC S.p.A
Via del Piano s.n
61030 Isola del Piano (PU)
Italia

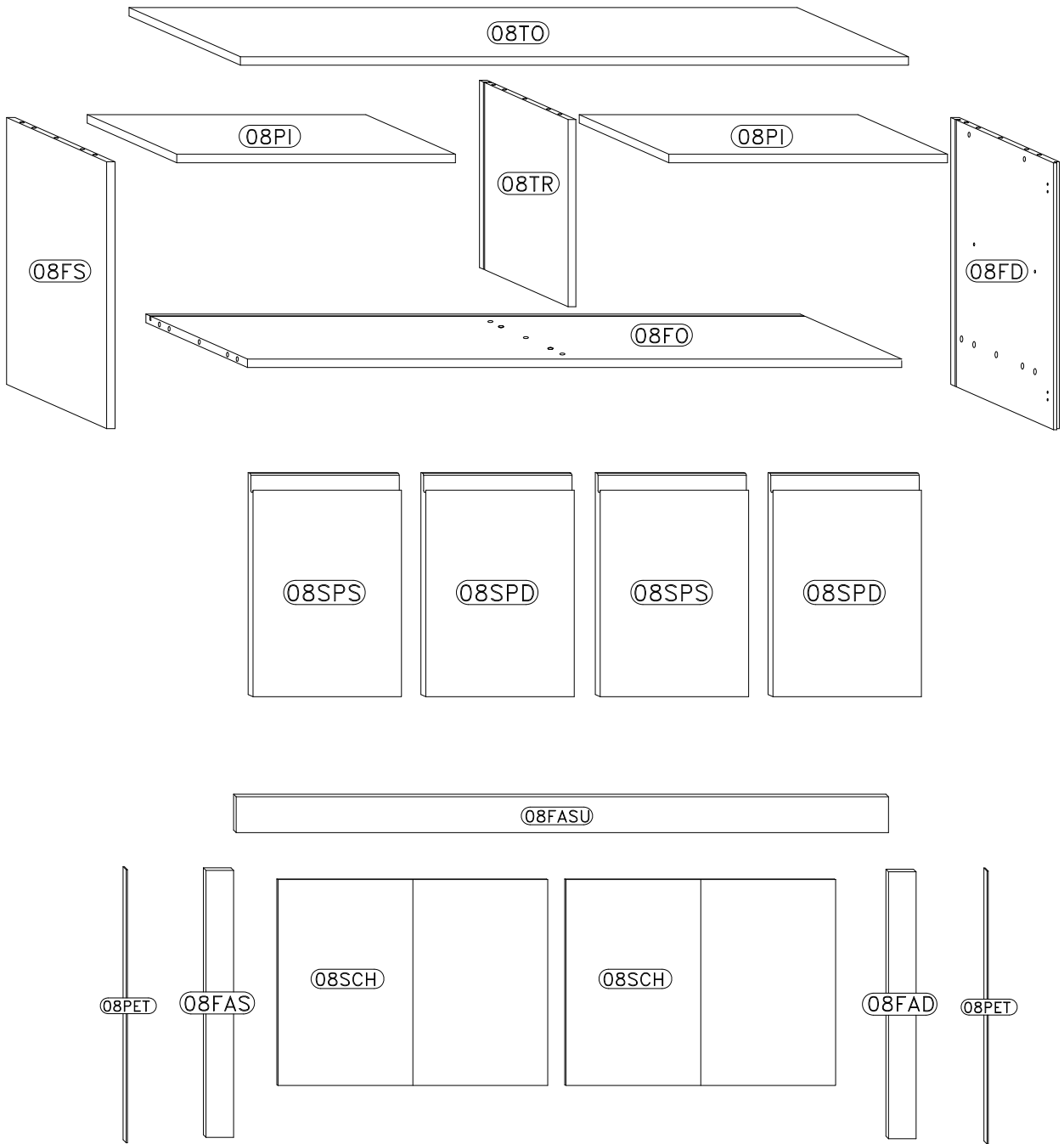
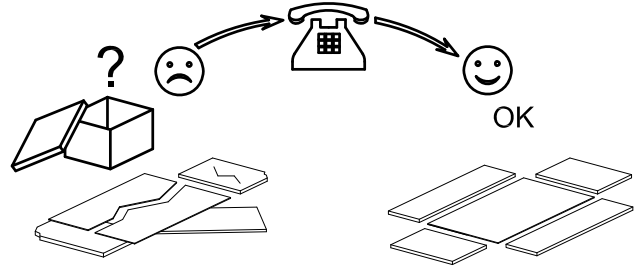
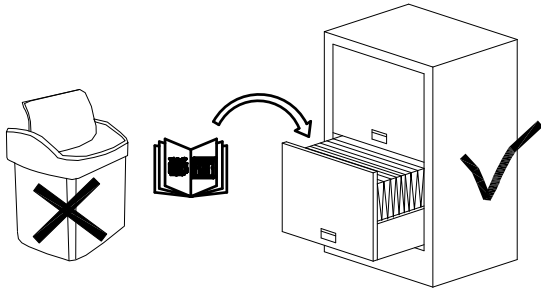

S E R V I C E K A R T E



ONDERDELEN LYST-SERVICEKARTE-FORMULAIRE DEMANDES SAV-SPAREPARTS LIST-SCHEDA DI SERVIZIO

BESLAG-BESCHLAEGE - QUINCALLERIE - HARDWARE - FERRAMENTA

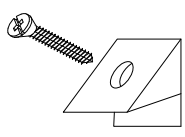
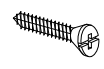
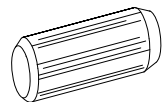
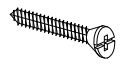
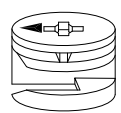

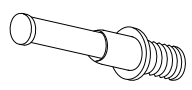
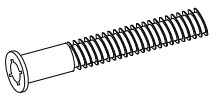
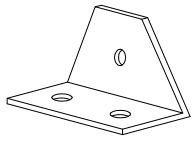
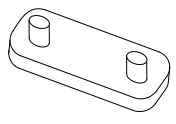
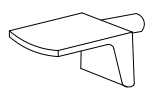
209006-08CF

A		L2		
	x20		4x16 mm.	x20
B	 8x30 mm.	L3		
	x22		4x18 mm.	x24
C	 ø16 mm.	P		
	x10		x4	
D		x10		
E1	 5x50 mm.	P7		x8
F1		x4	R	 x8

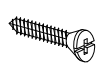
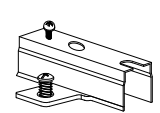
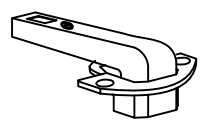

200505-08CC

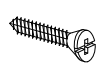
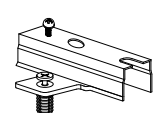
L2			x8
	4x16 mm.		
N1		H4	x4
O1			x4

521030-01CC

L2			x8
	4x16 mm.		
N		H2	x4
O2			x4

209006-01PIE

F2			
			x1

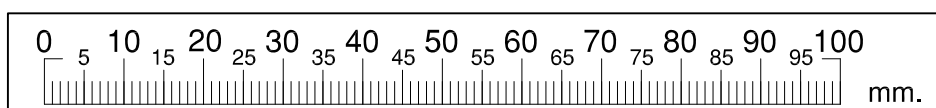

1

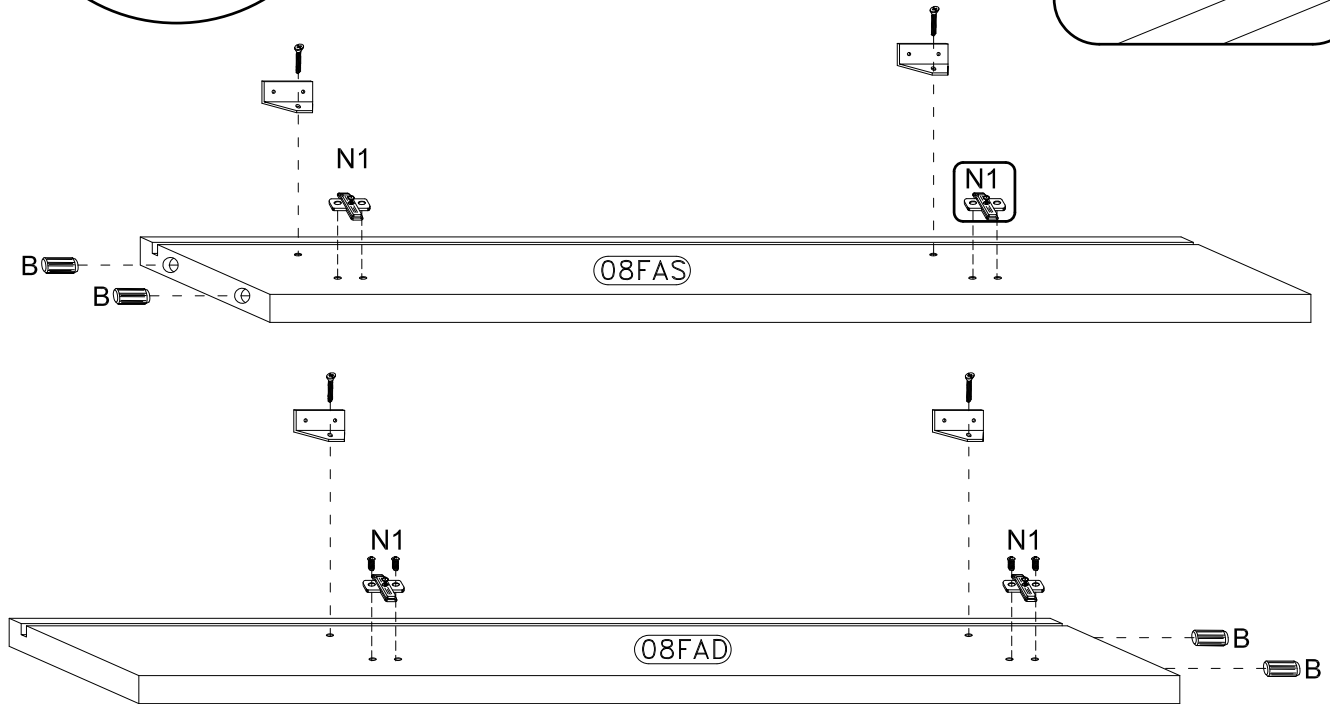
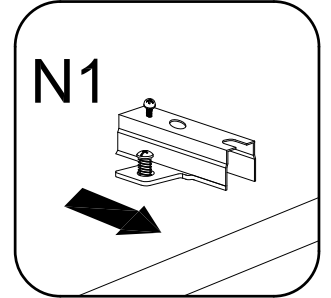
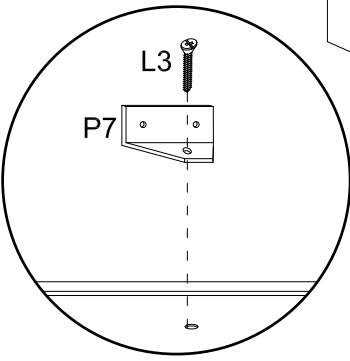
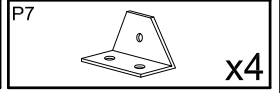
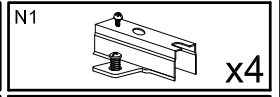
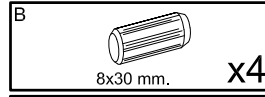
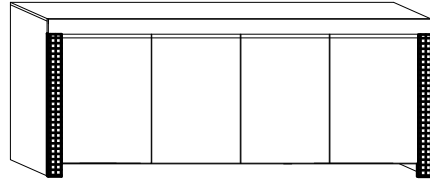

2

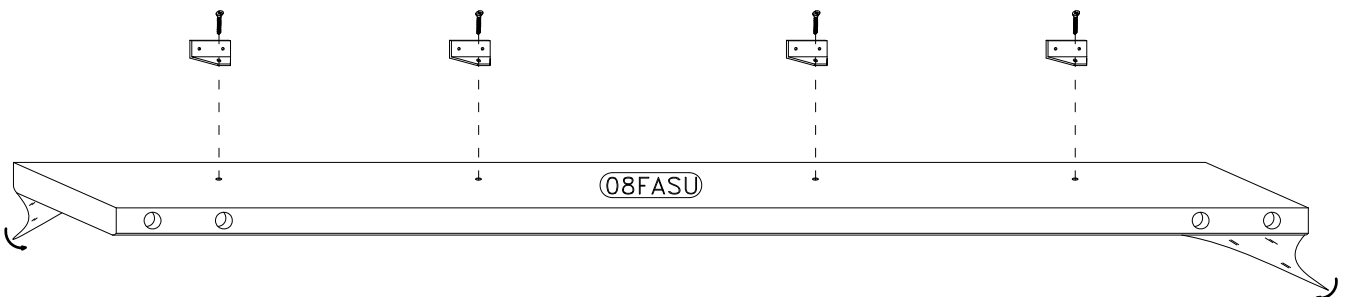
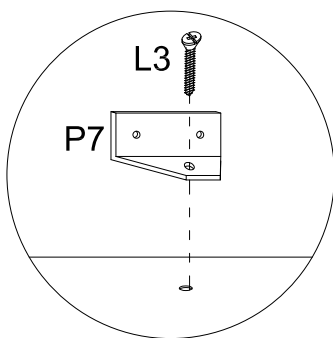
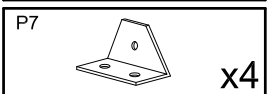
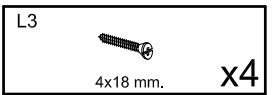
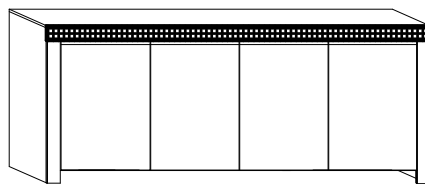

3

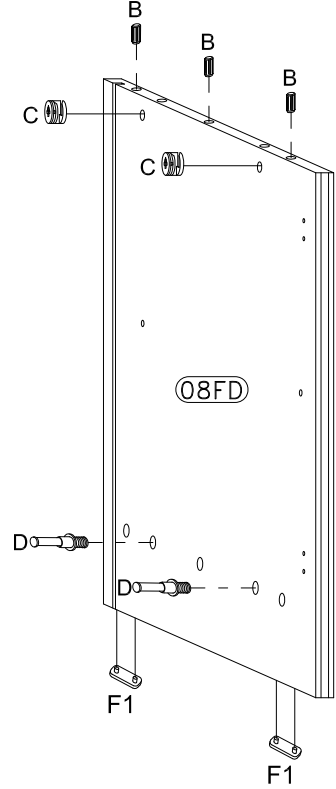
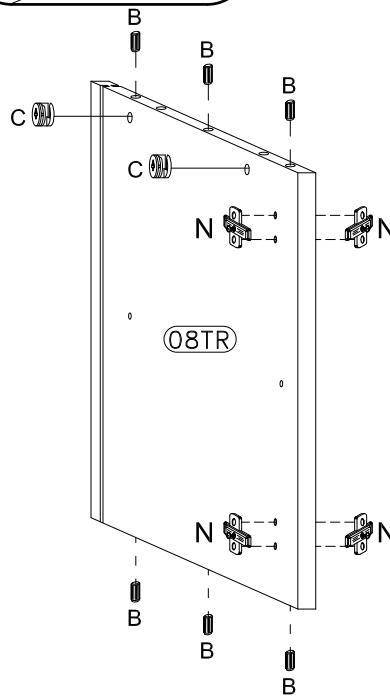
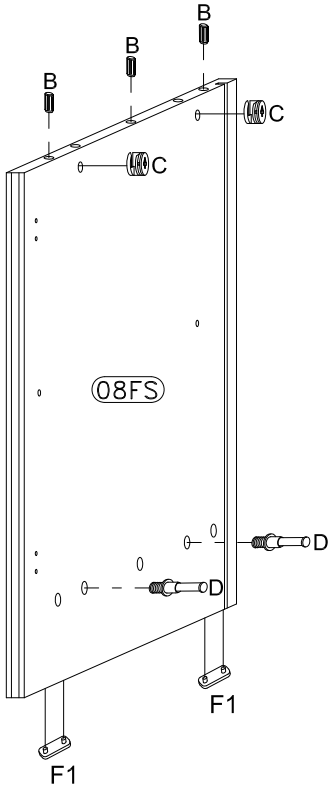
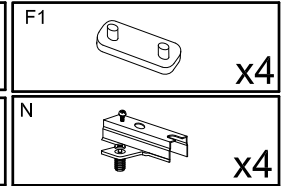
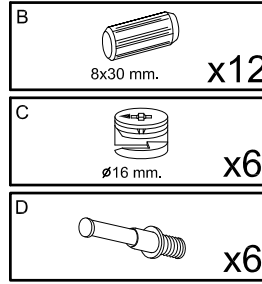
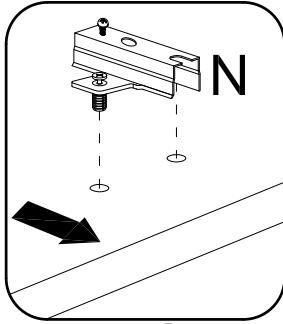
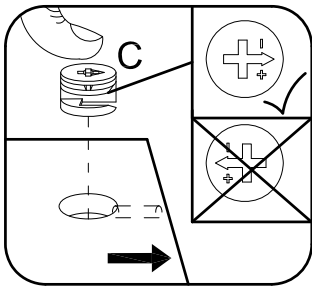

4

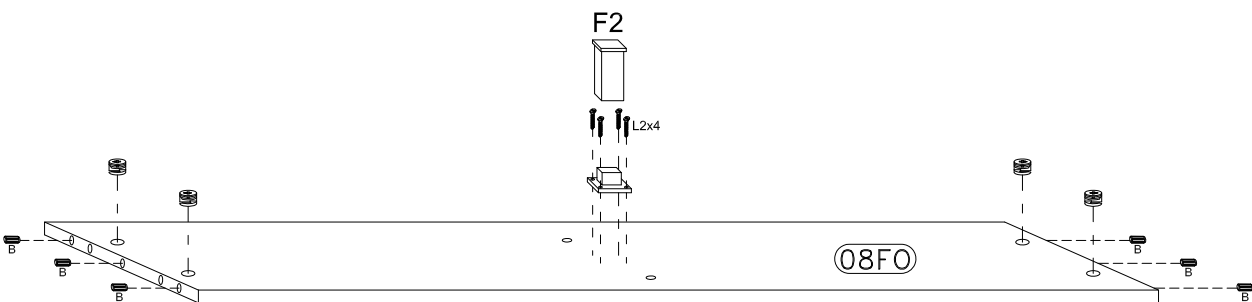
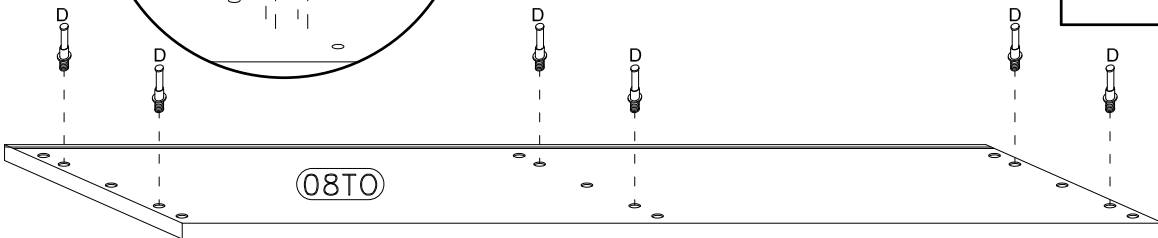
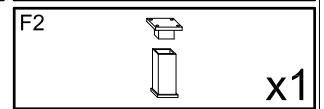
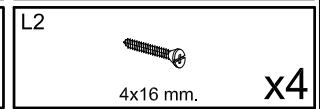
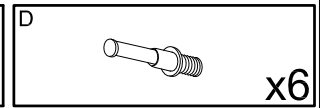
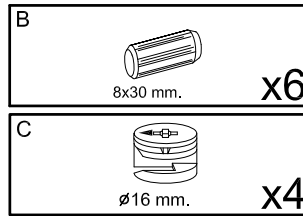
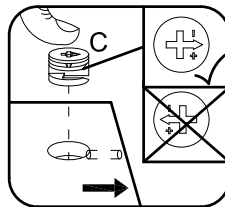
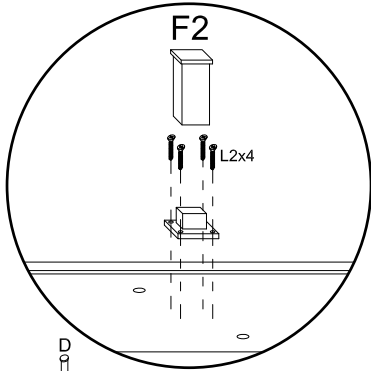

5

E1
5x50 mm. x2

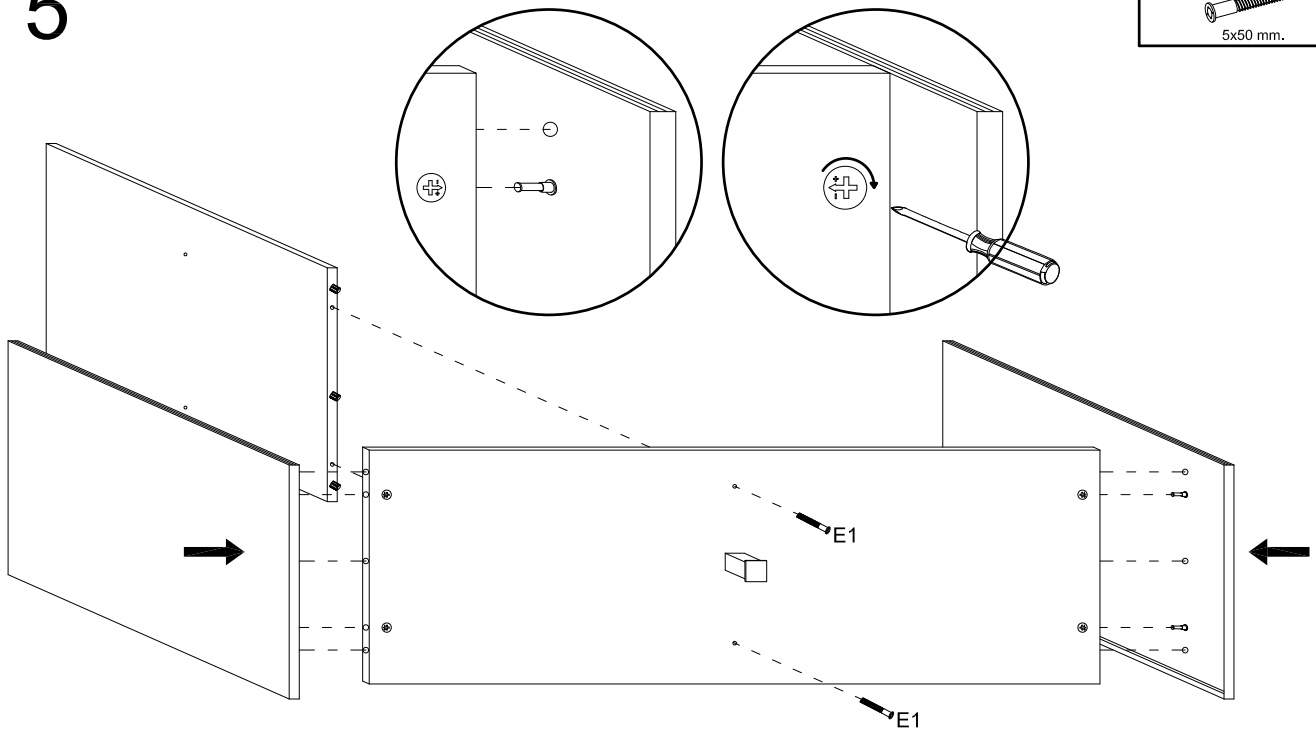

6

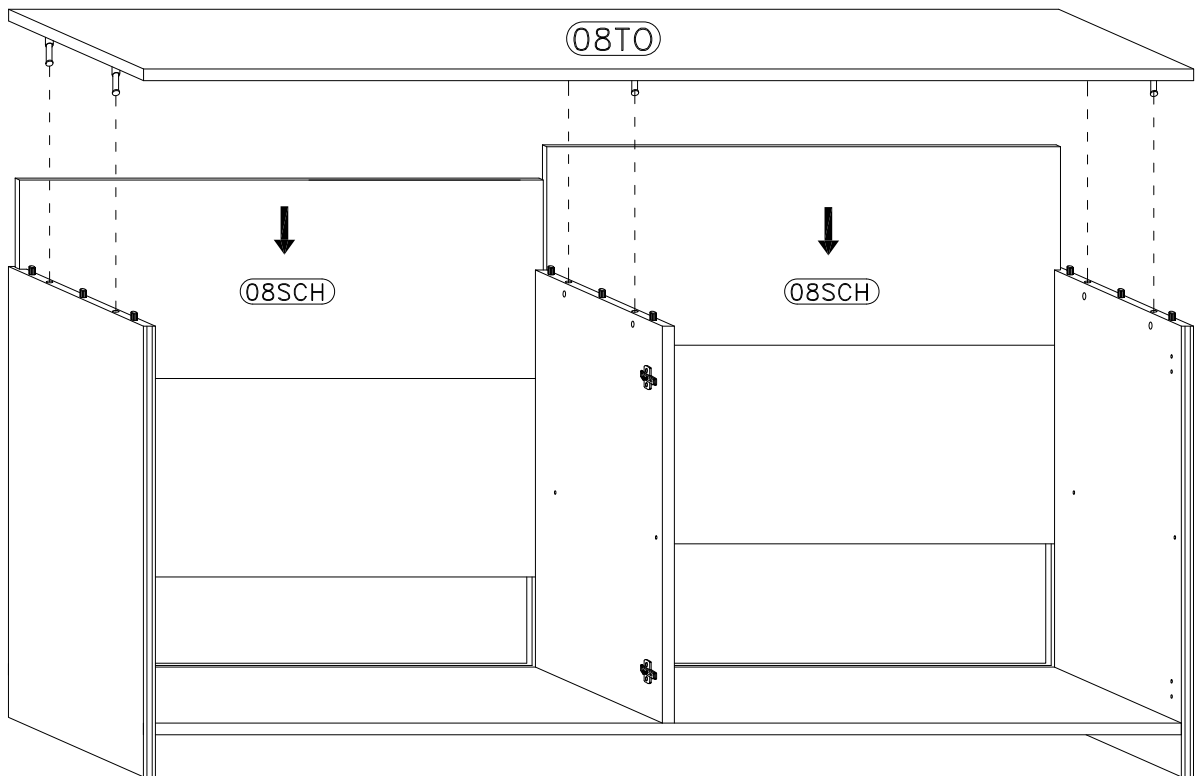
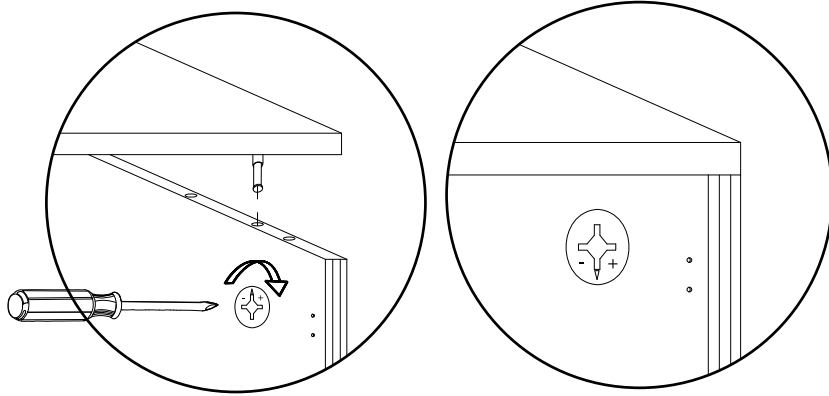

7

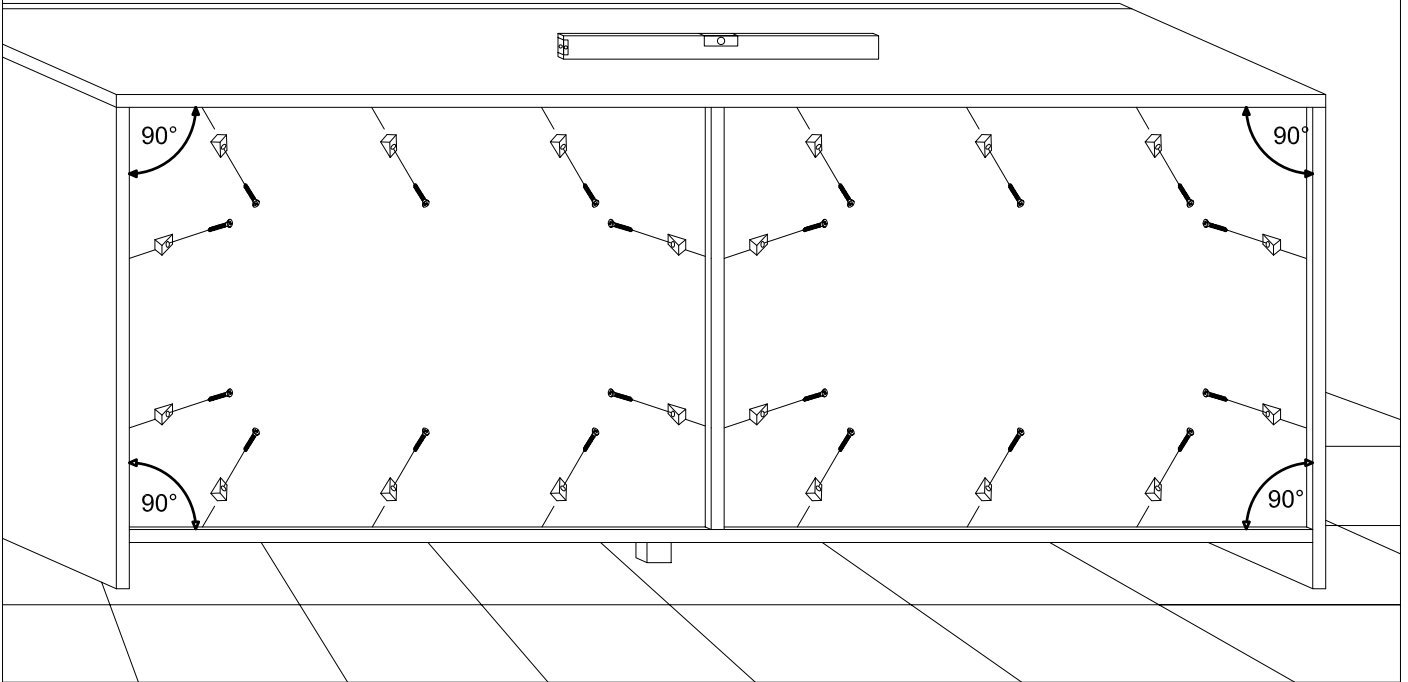
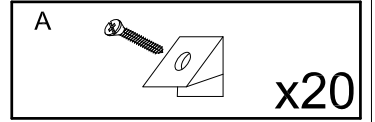
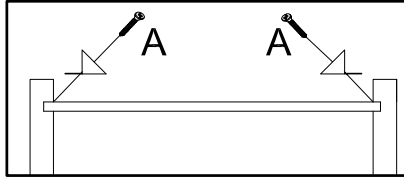

8

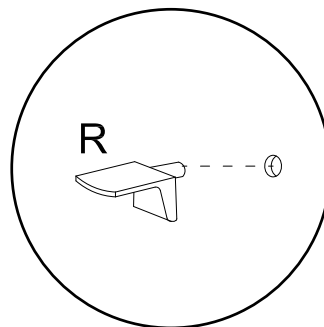
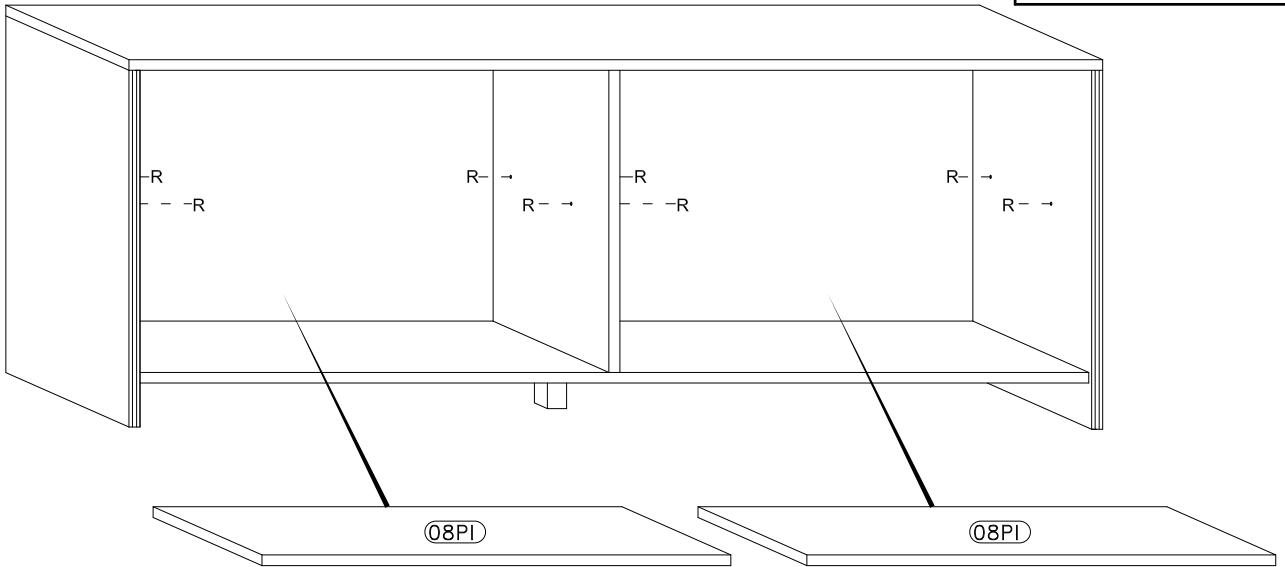
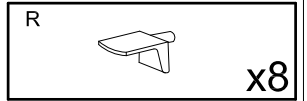

9

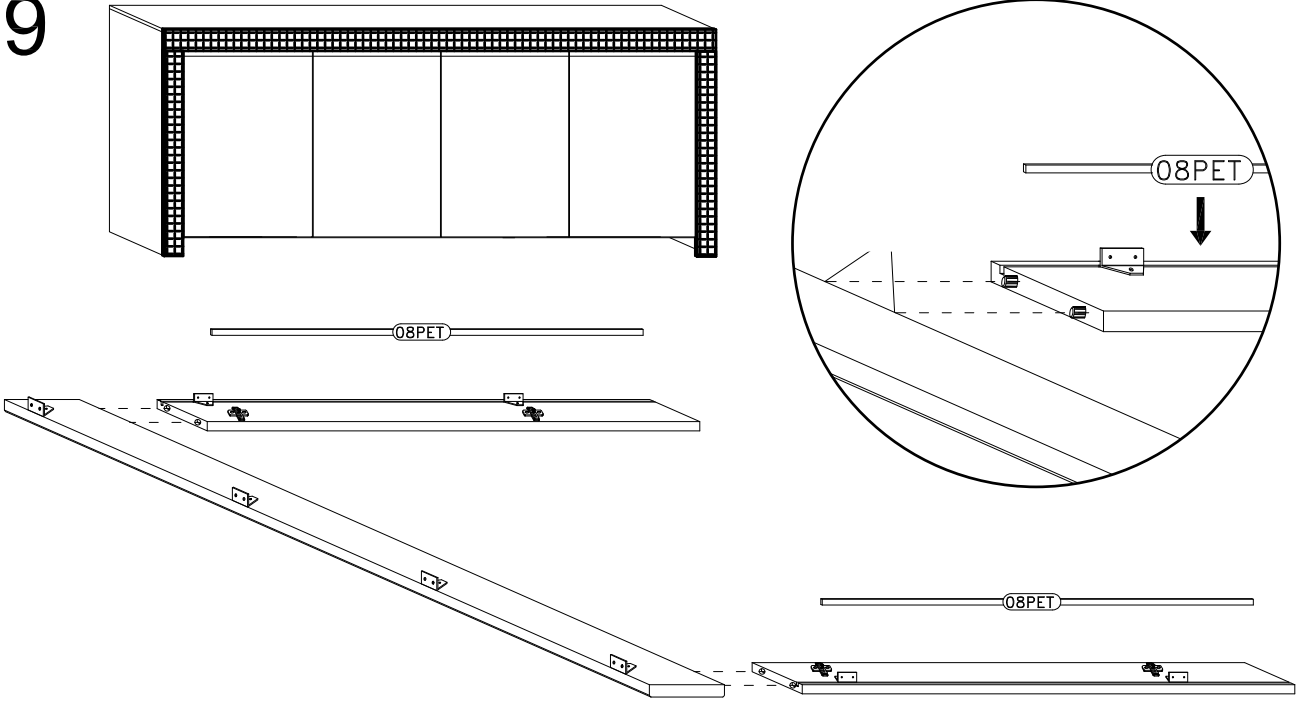

10

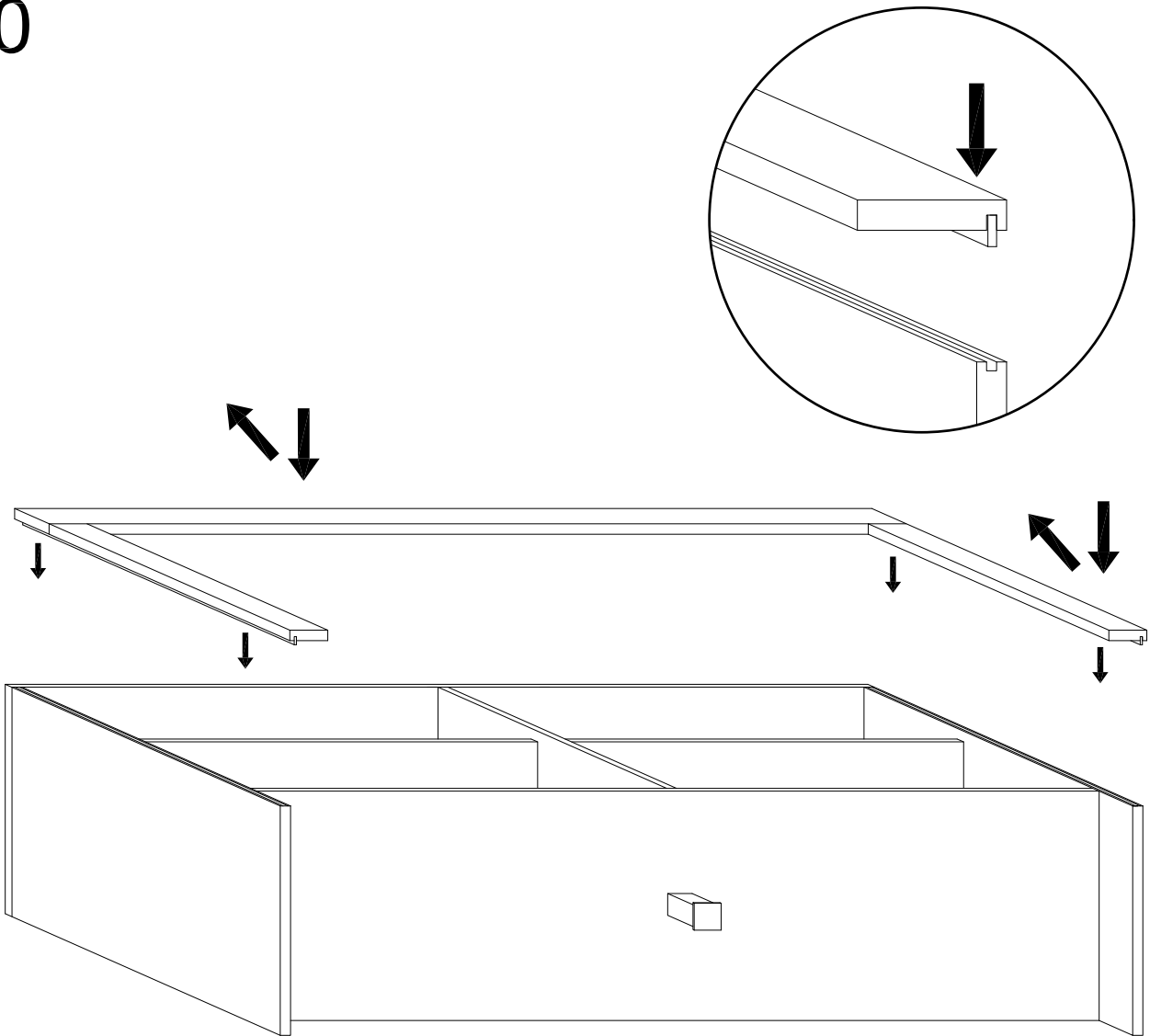



Attenzione!!! Aprire le cerniere prima del montaggio
Attention!!! Open hinges before assembly
Achtung!!! Scharniere vor der Montage öffnen
Attention!!! Ouvrir les charnières avant l'assemblage
Atención!!! Abrir las bisagras antes del montaje



1



2



3



11

L3
4x18 mm. x16

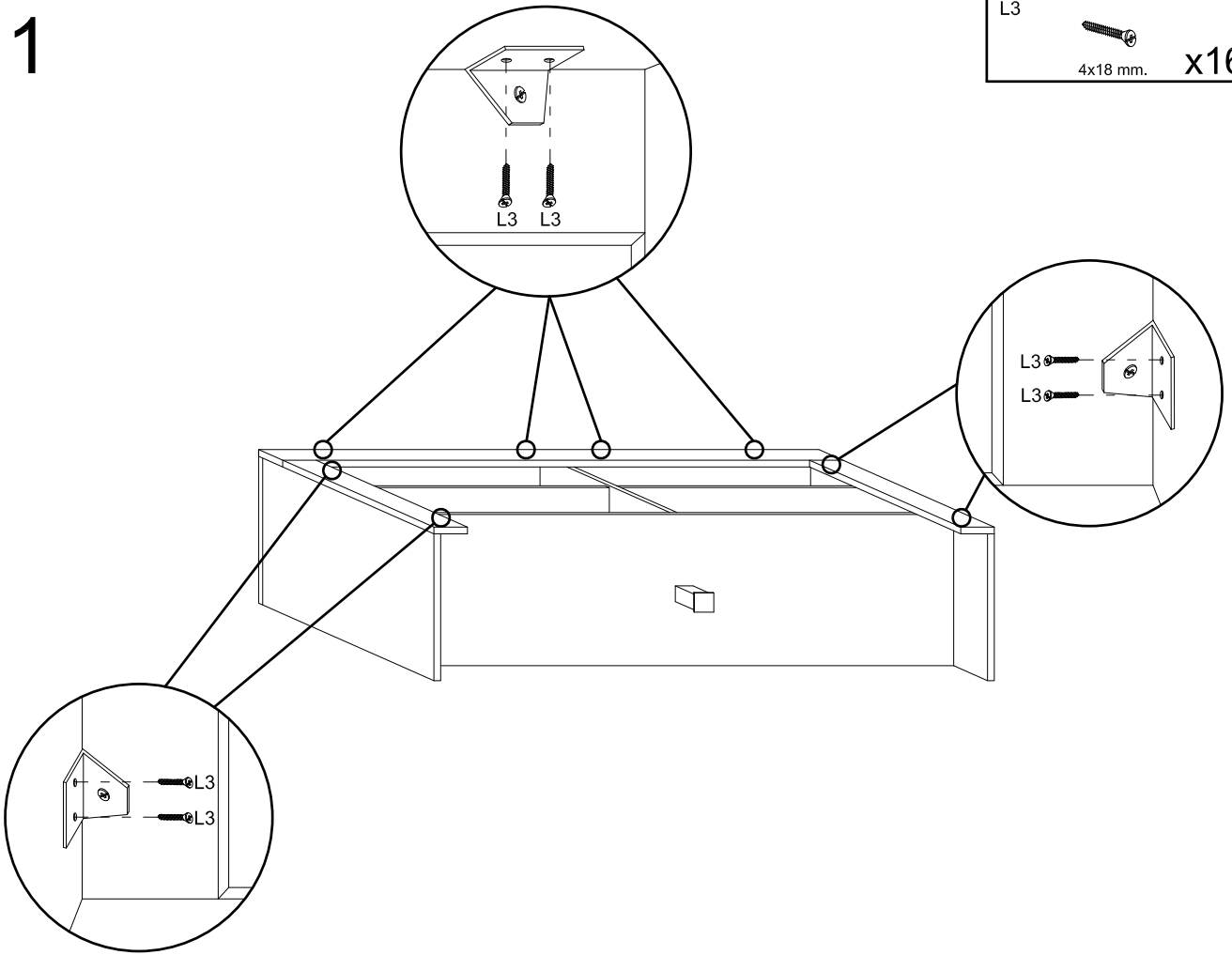

12

O1
x4

O2
x4

L2
4x16 mm. x16

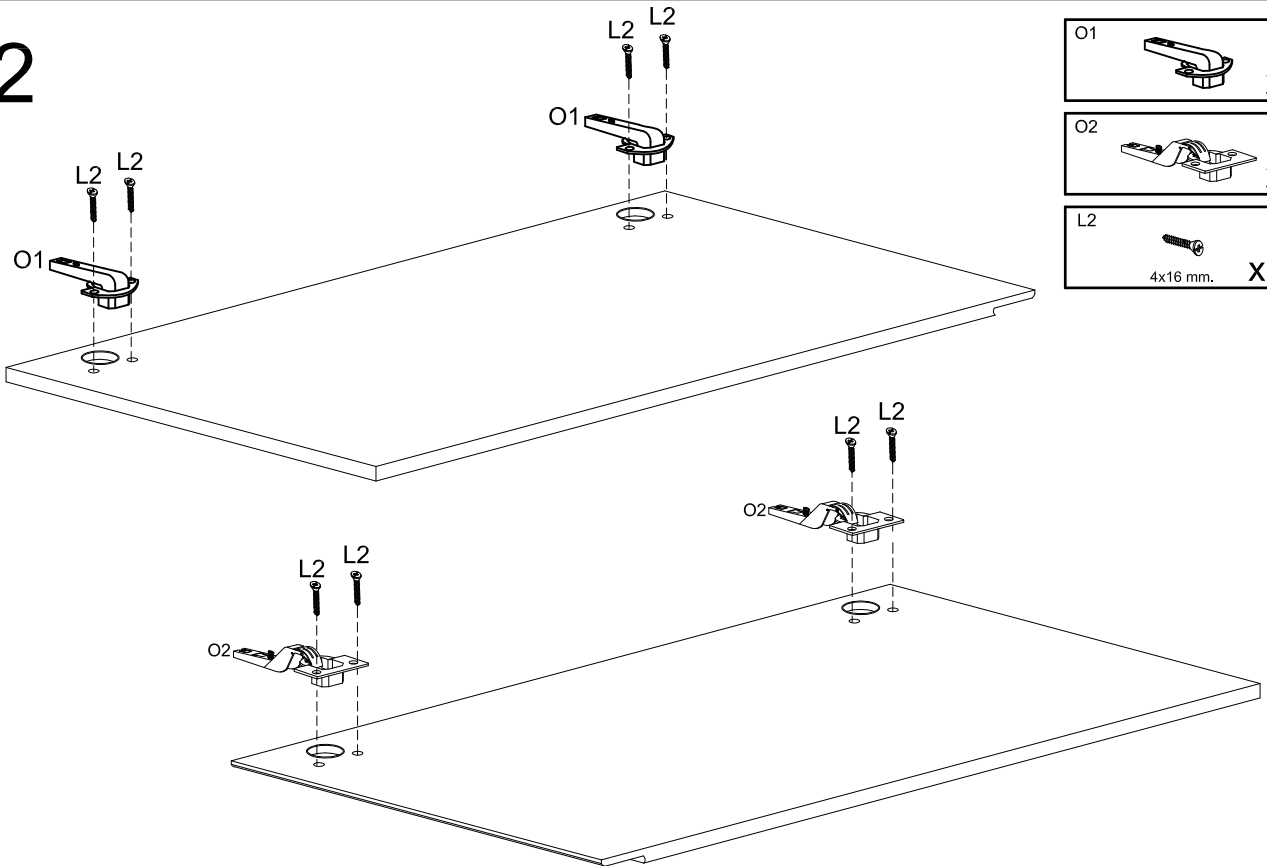

13

