

REPC-Nr.:

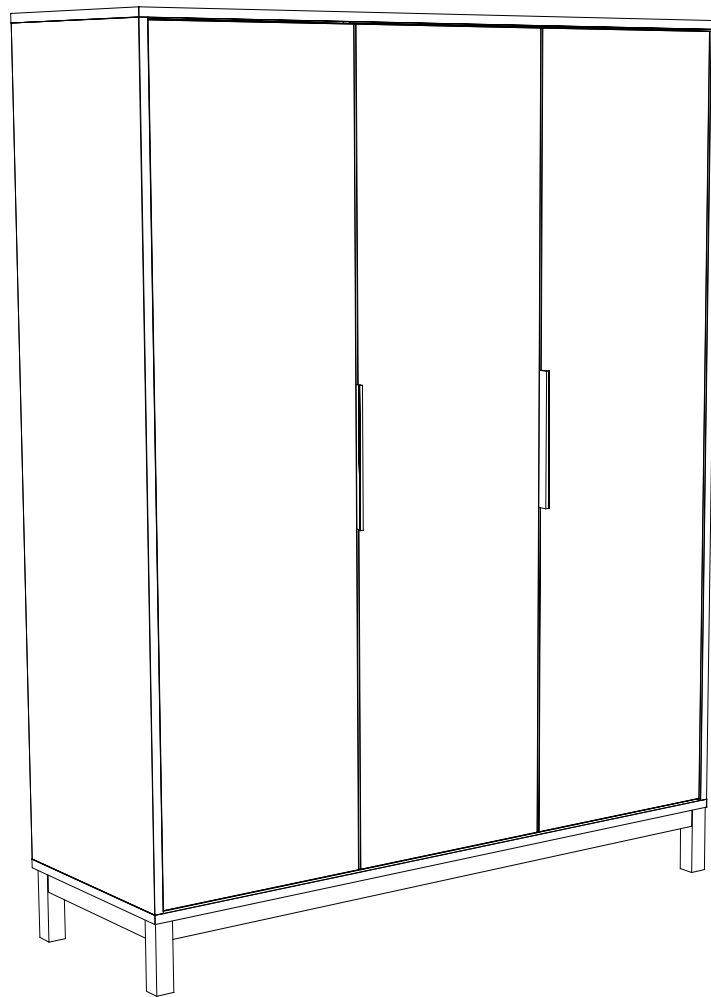

Artikel.-Nr.:

4004-KS-3

Montageanleitung.-Nr.:

MA1-00831

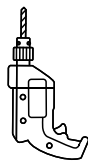
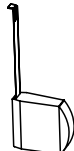
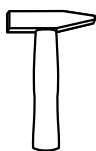
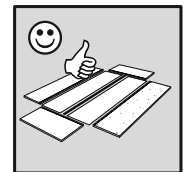
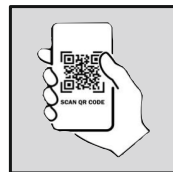
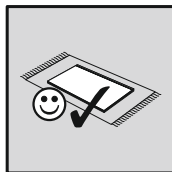
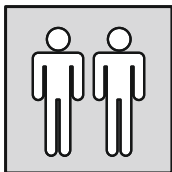
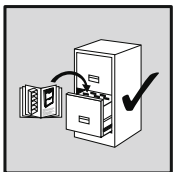

L = 20 mm

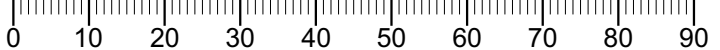

Das Ersatzteil-Anforderungsformular finden Sie auf
The replacement parts requisition form you find on
<https://www.mausbacher.de/ersatzteile/>

Colli 1/3

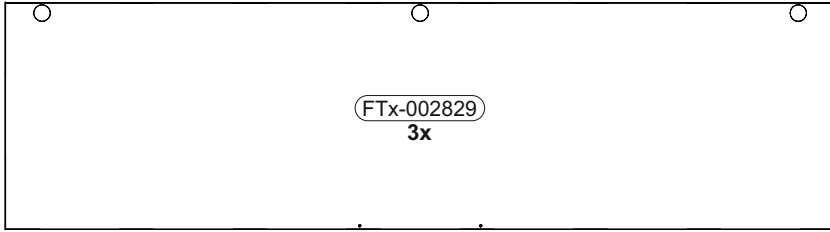

1756 x 480

Colli 2/3

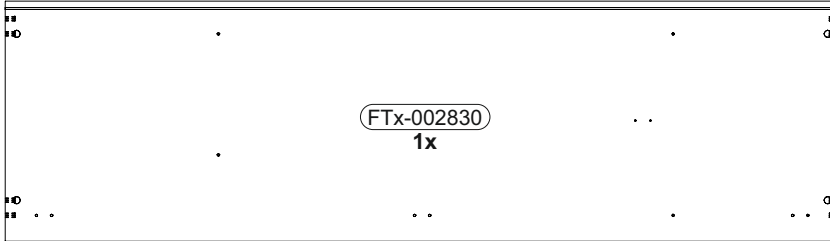

1764 x 508

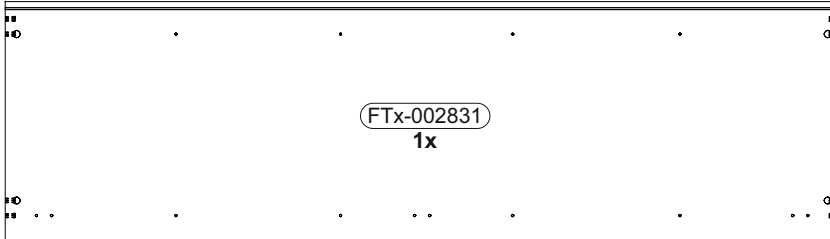

1764 x 508

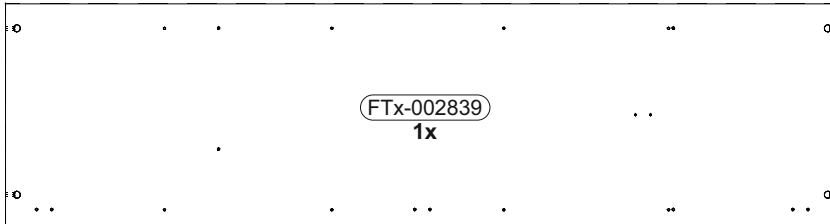

1764 x 471

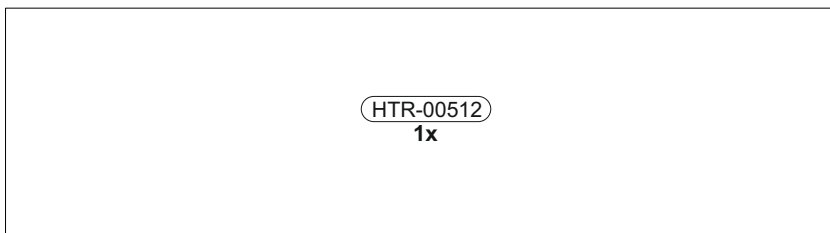

1776 x 480

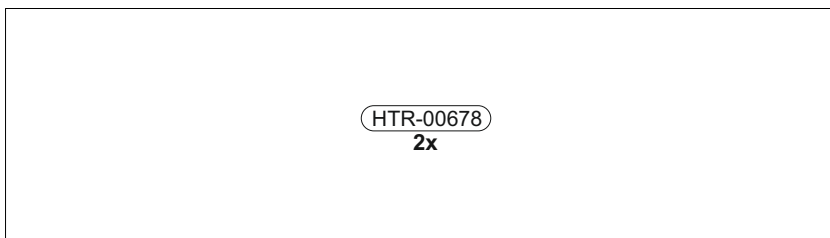

1776 x 490





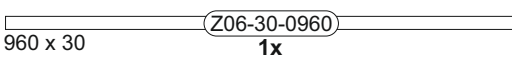





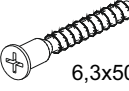
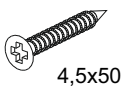

1740 x 20



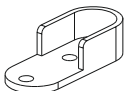

960 x 30

BT1-00920

B01-10 5x 	B01-174 8x 	B01-200 4x 
B01-30 27x 	B01-80 22x 	B01-90 6x 
B02-103 8x 	B02-114 2x 	B02-160 14x 
B05-185 6x 	B08-80 1x 	B02-10 26x 

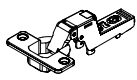
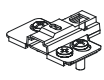
BT1-00921

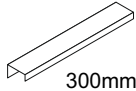
B03-03 9x 	B03-05 9x 
	
B06-423 2x 	300mm

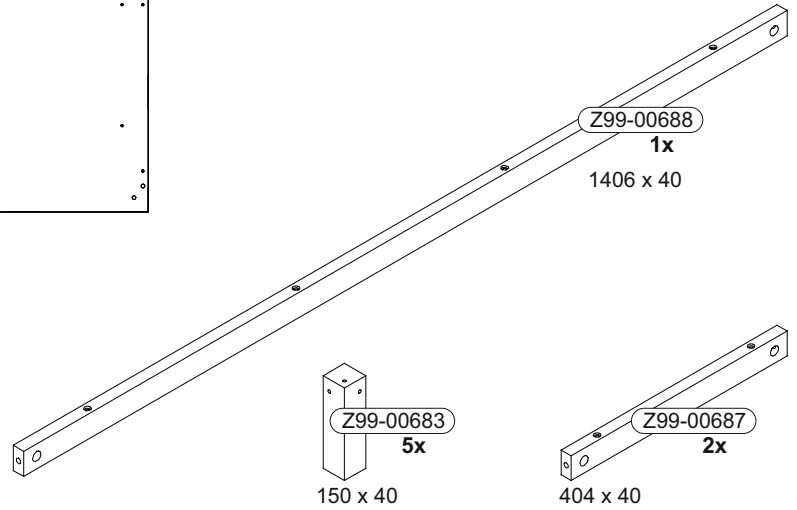
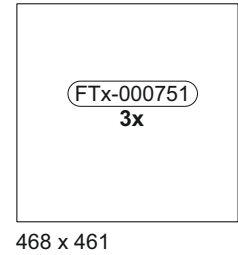
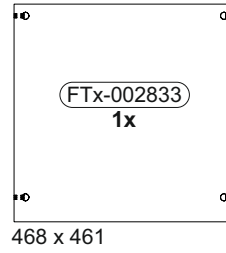
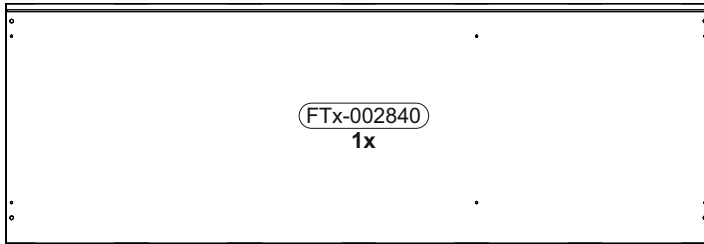





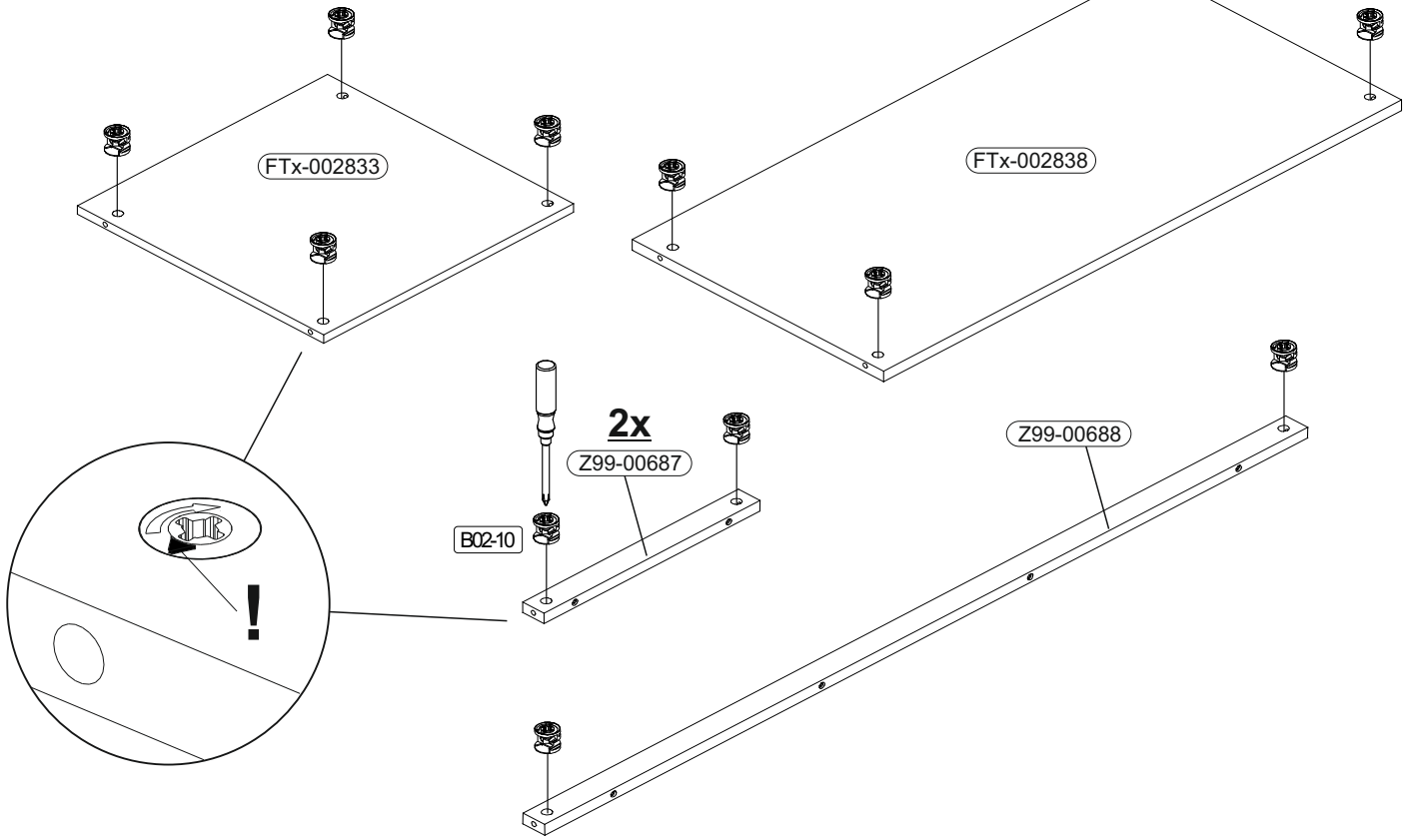

1

+	B02-10		ø15x12mm
	14x		

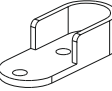

2

+		B02-20		B03-05		B02-114		B02-103		B02-10		ø15x12mm
		2x		3x		1x		4x		8x30		
		B01-80										
		2x		3,5x13								

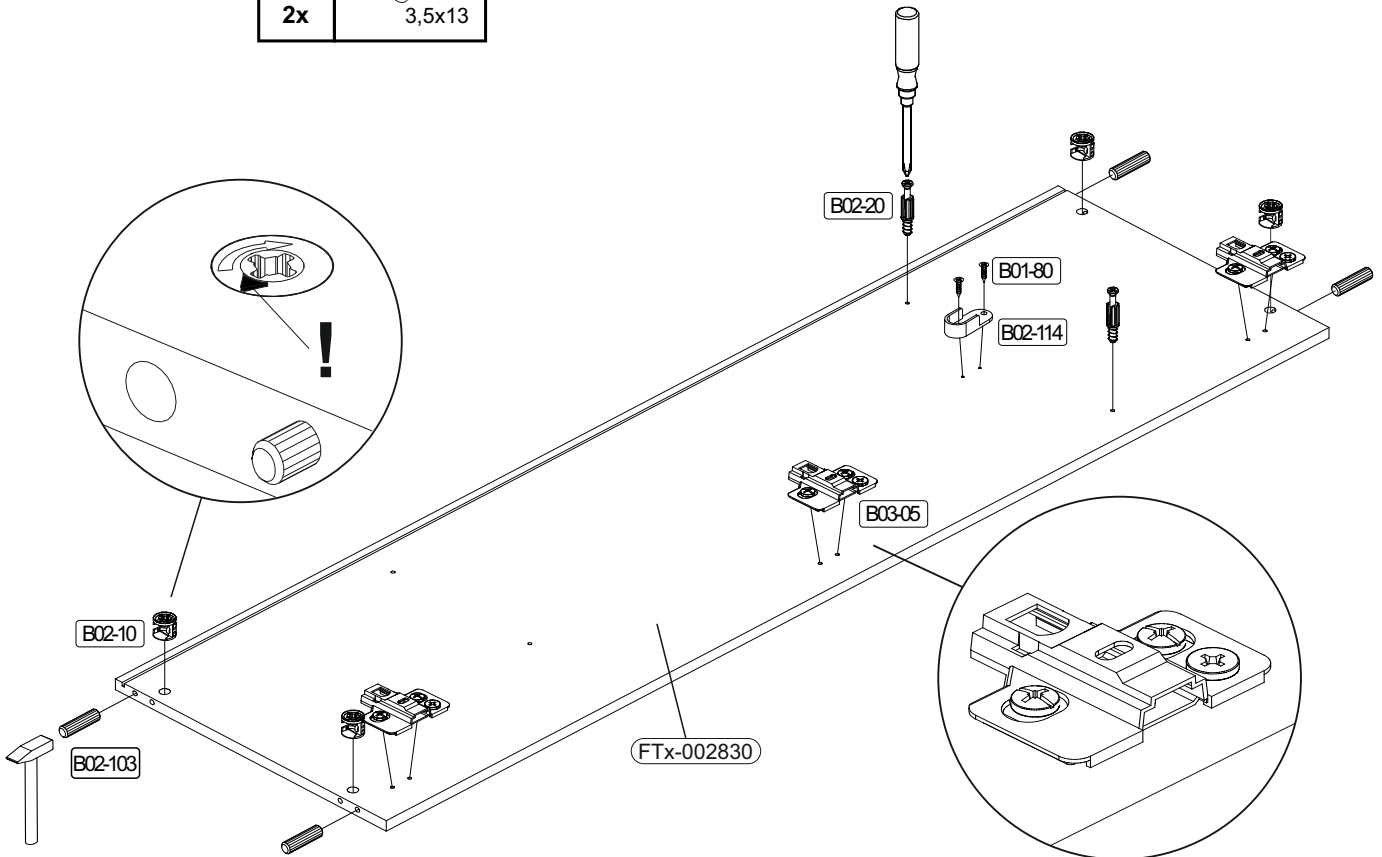

3

		<table border="1"><tr><td>B02-20</td></tr><tr><td>2x</td></tr></table>	B02-20	2x		<table border="1"><tr><td>B03-05</td></tr><tr><td>3x</td></tr></table>	B03-05	3x		<table border="1"><tr><td>B02-160</td></tr><tr><td>6x</td></tr></table>	B02-160	6x		<table border="1"><tr><td>B02-103</td></tr><tr><td>4x</td></tr></table>	B02-103	4x		8x30	<table border="1"><tr><td>B02-10</td></tr><tr><td>4x</td></tr></table>	B02-10	4x		ø15x12mm
B02-20																							
2x																							
B03-05																							
3x																							
B02-160																							
6x																							
B02-103																							
4x																							
B02-10																							
4x																							

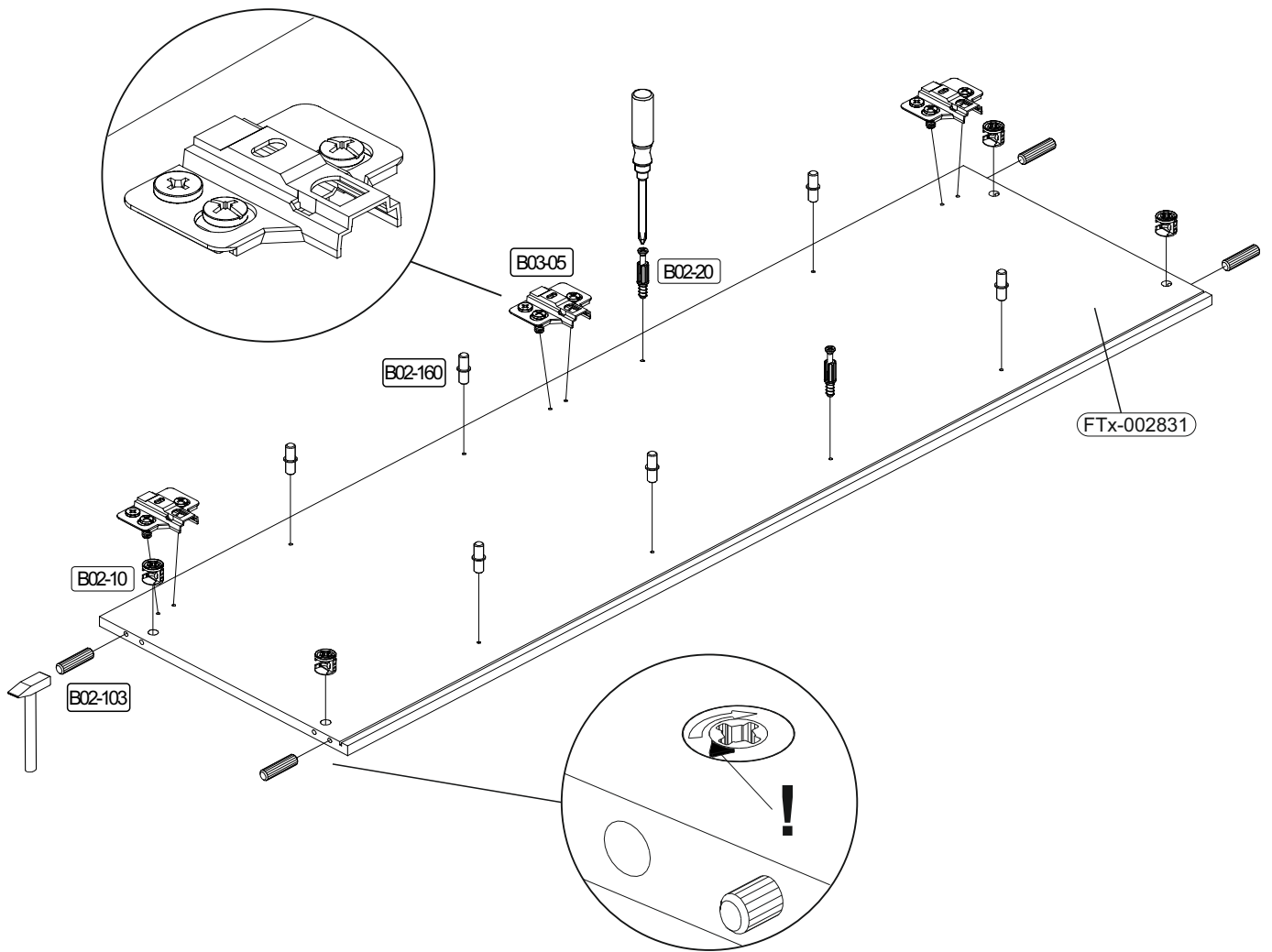





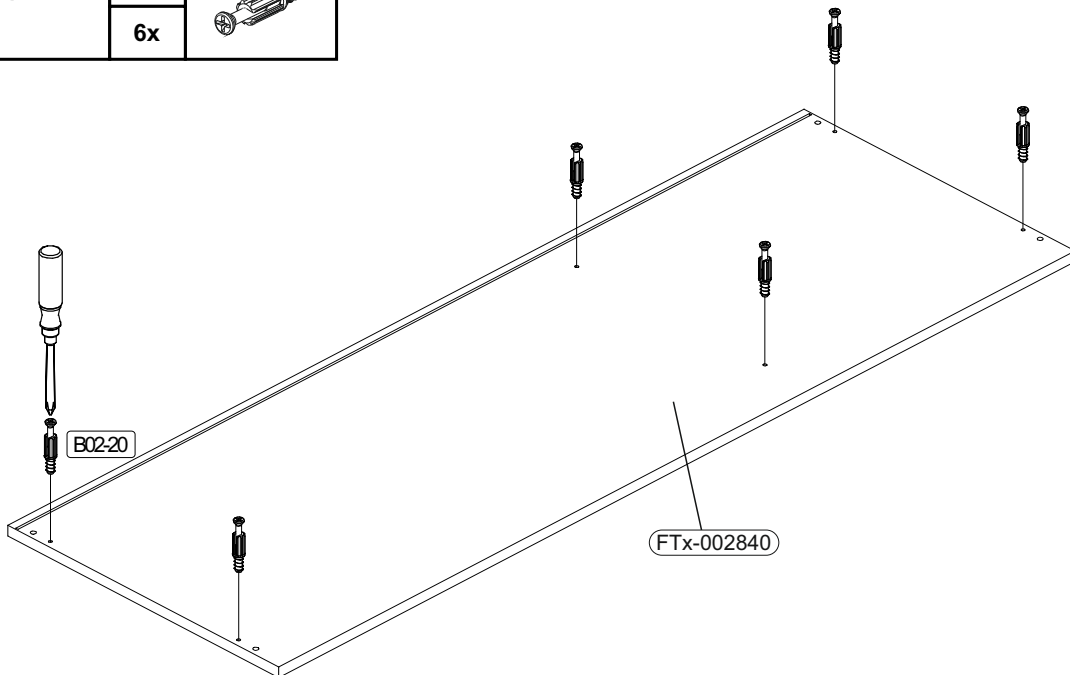

4

	<table border="1"><tr><td>B02-20</td></tr><tr><td>6x</td></tr></table>	B02-20	6x	
B02-20				
6x				



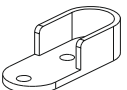

5

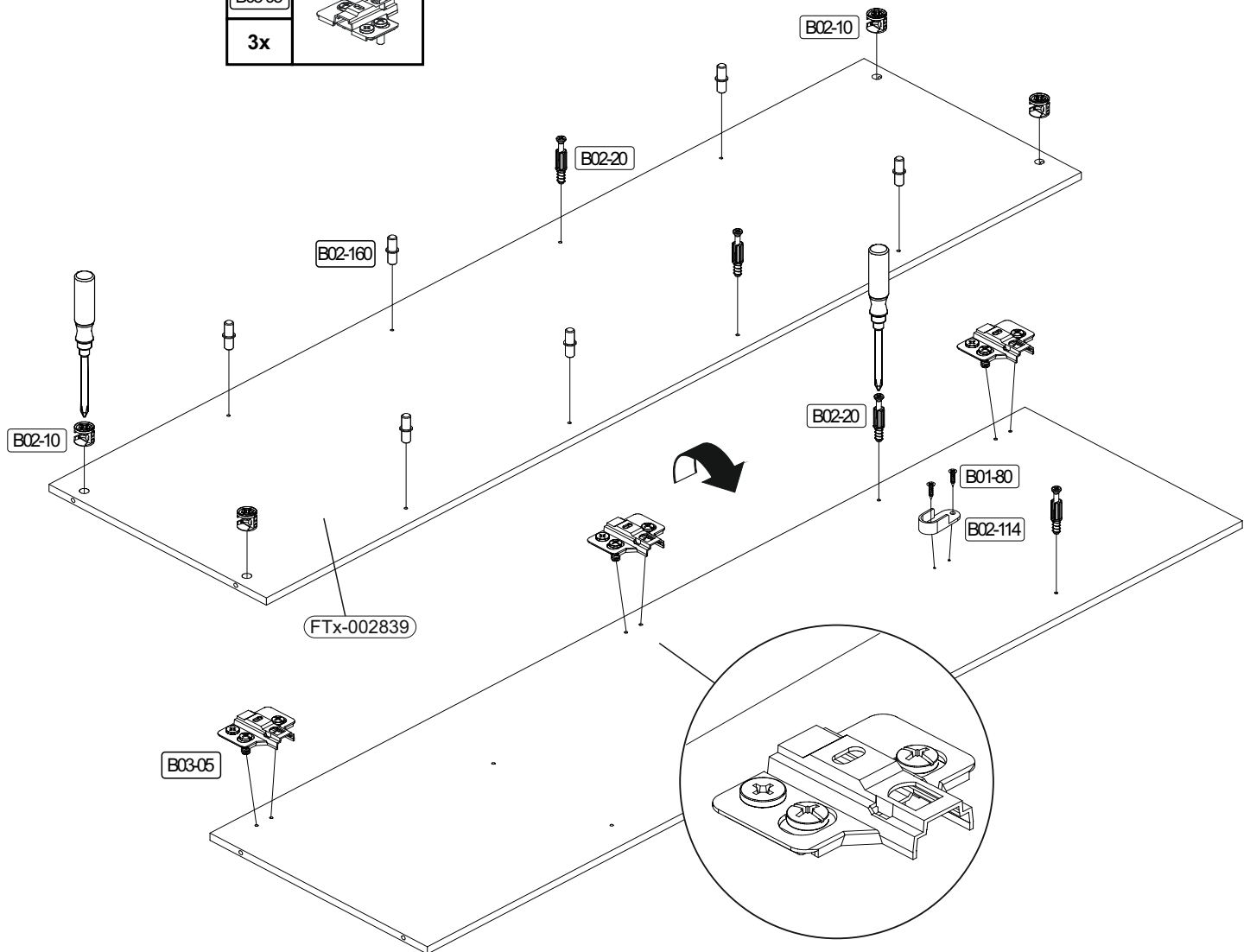
	B02-20		B02-10		B02-160		B02-114		B01-80	
	4x		4x		ø15x12mm		6x		1x	
	B03-05									
	3x									



6

	B02-20	
	6x	

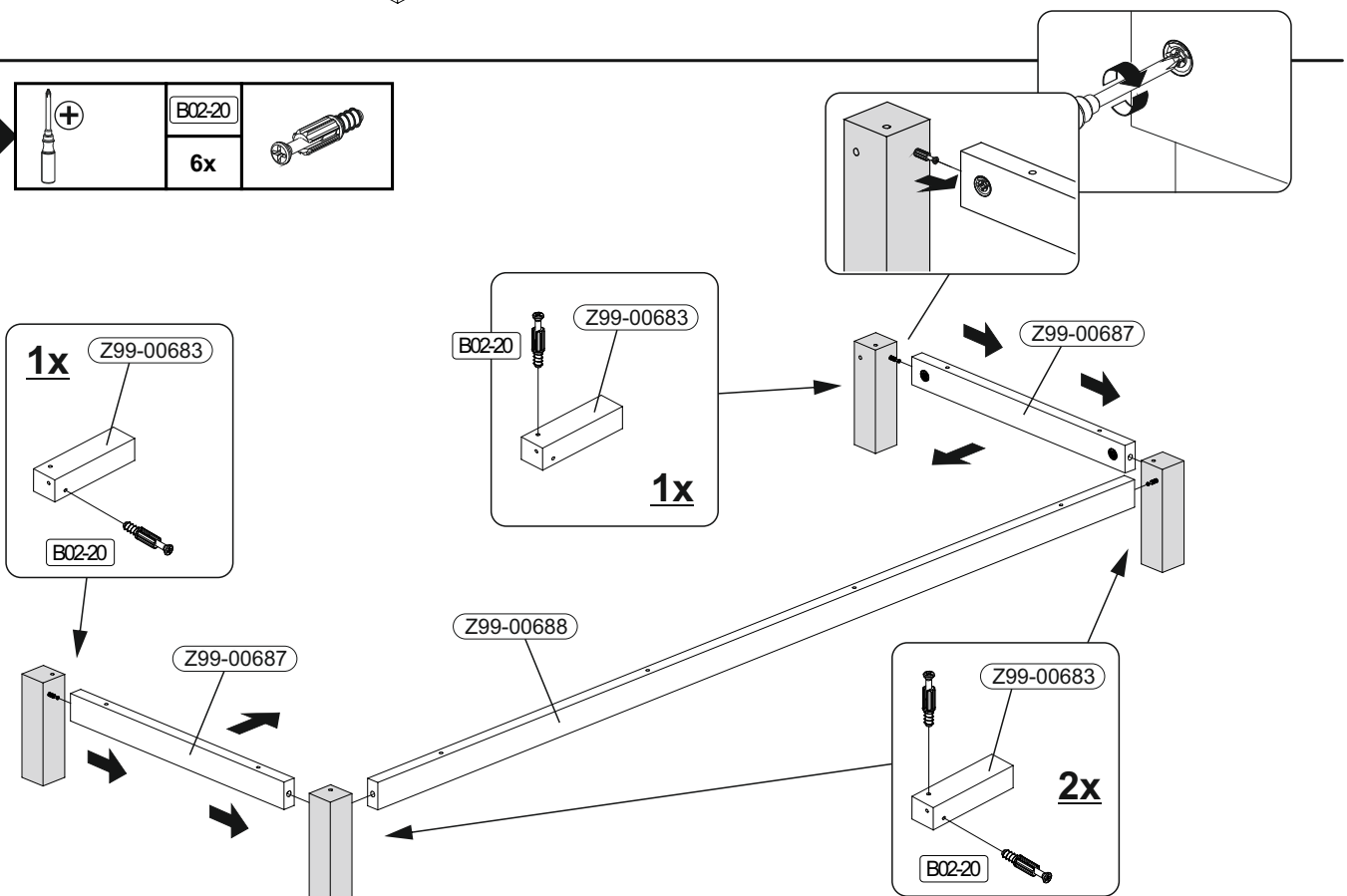

7

	B01-10	B01-174	B02-160	B02-20	B02-20
	5x	8x	2x	6x	
	6,3x50	4,5x50			

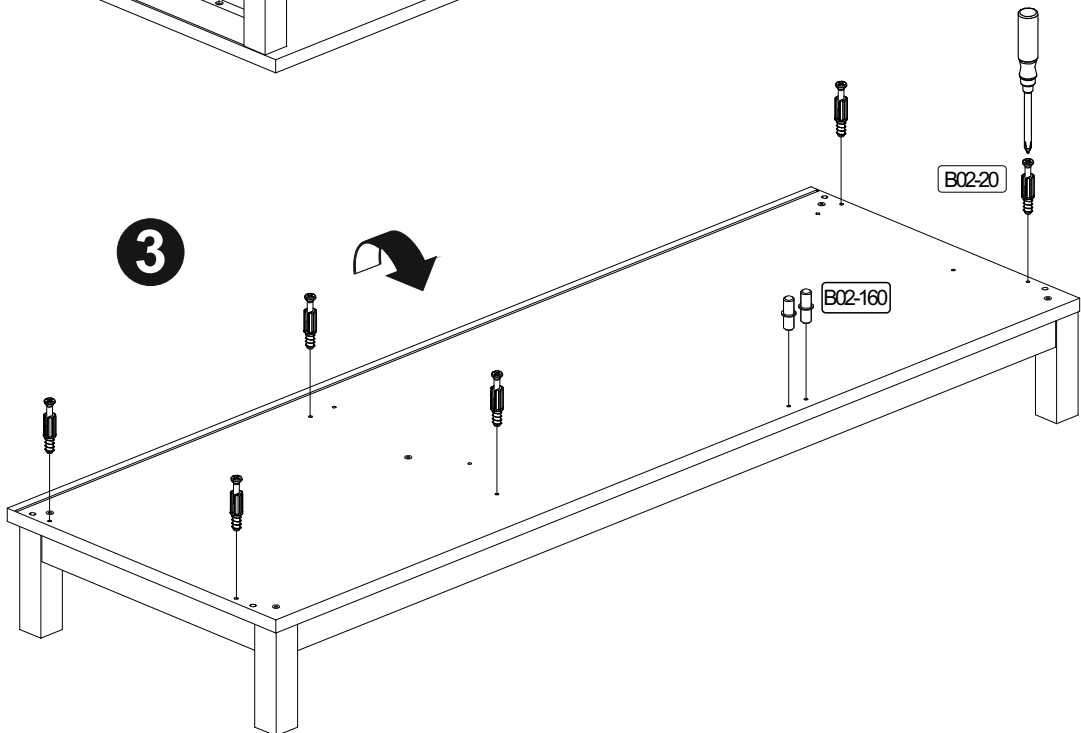
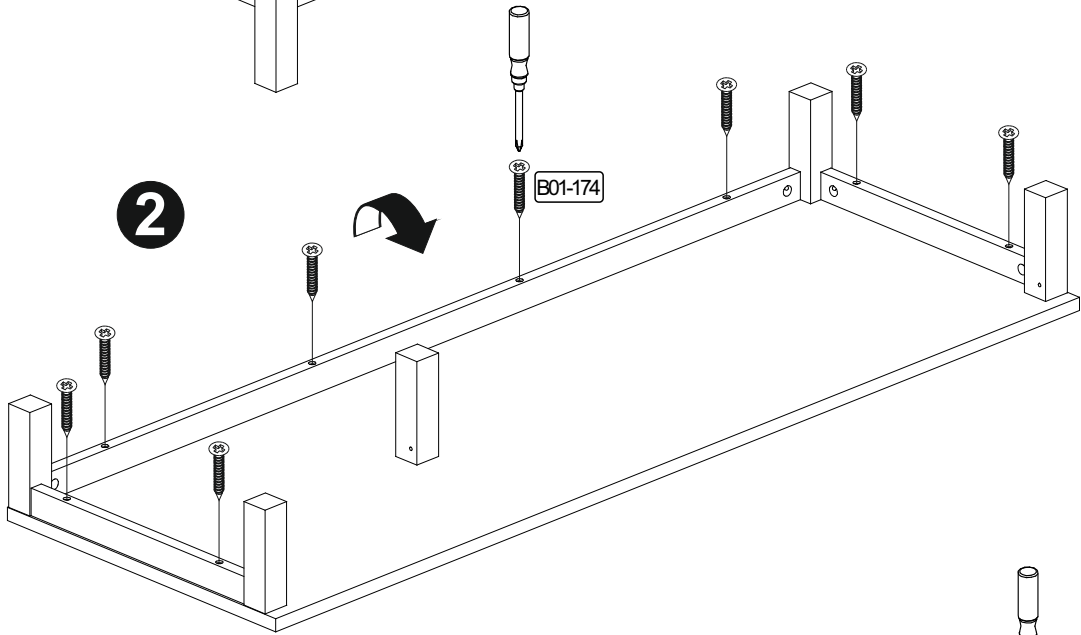
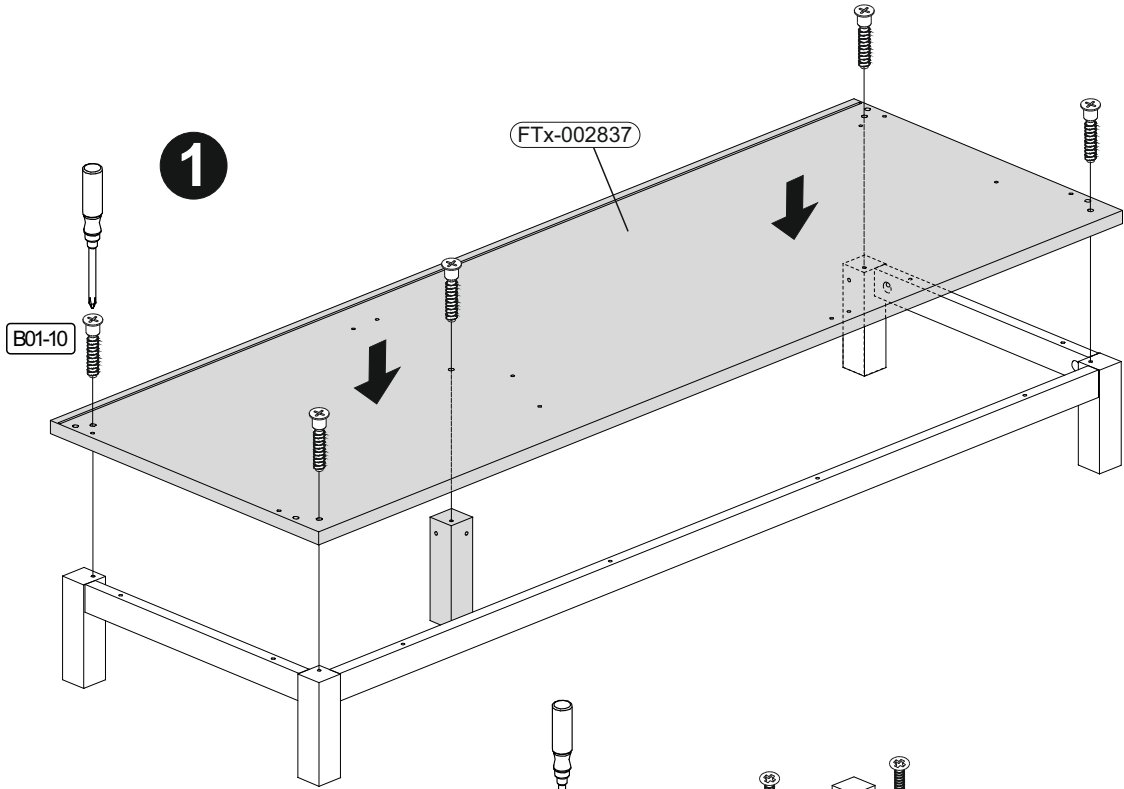

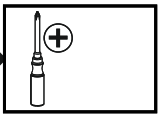
7 

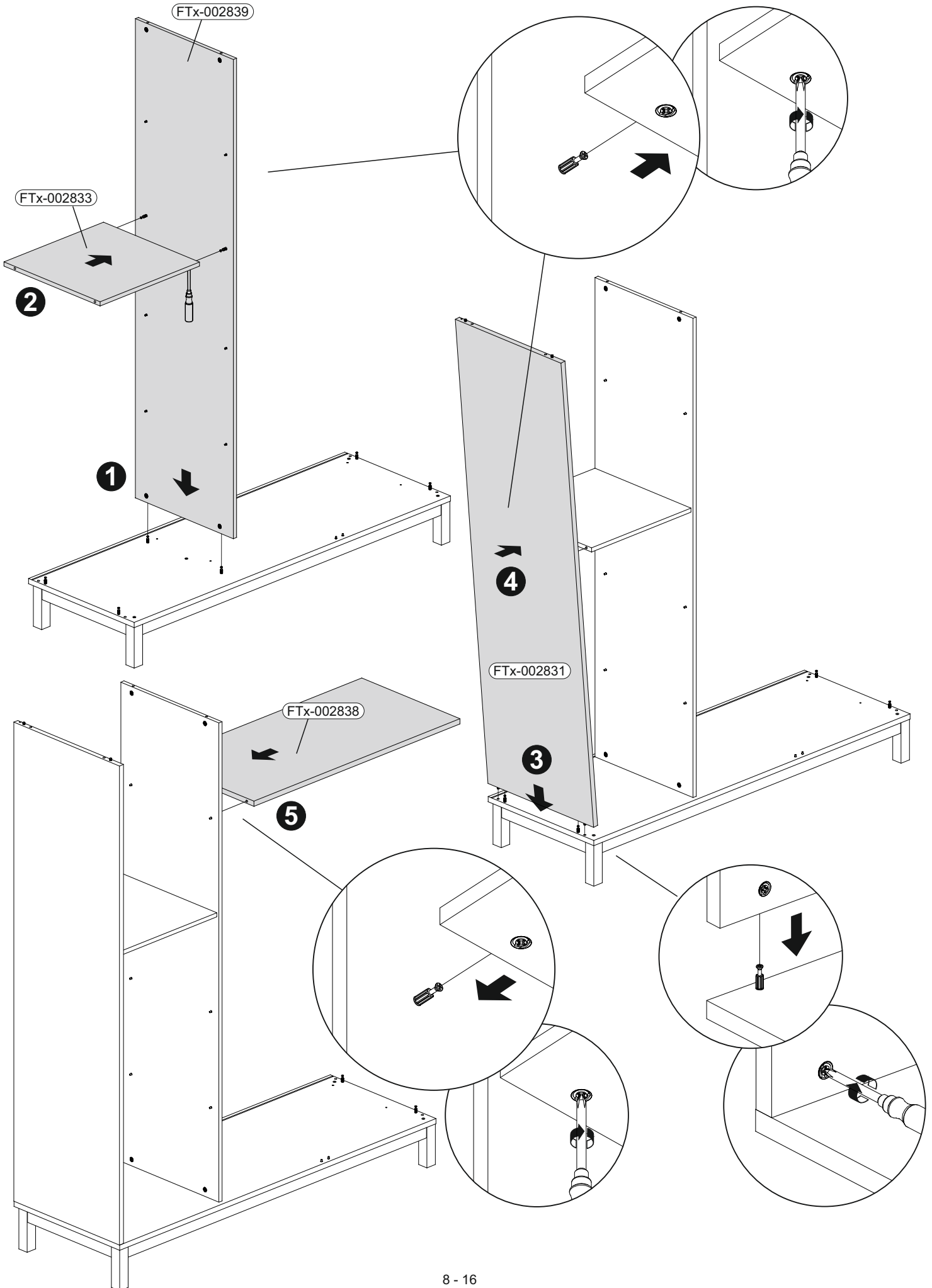

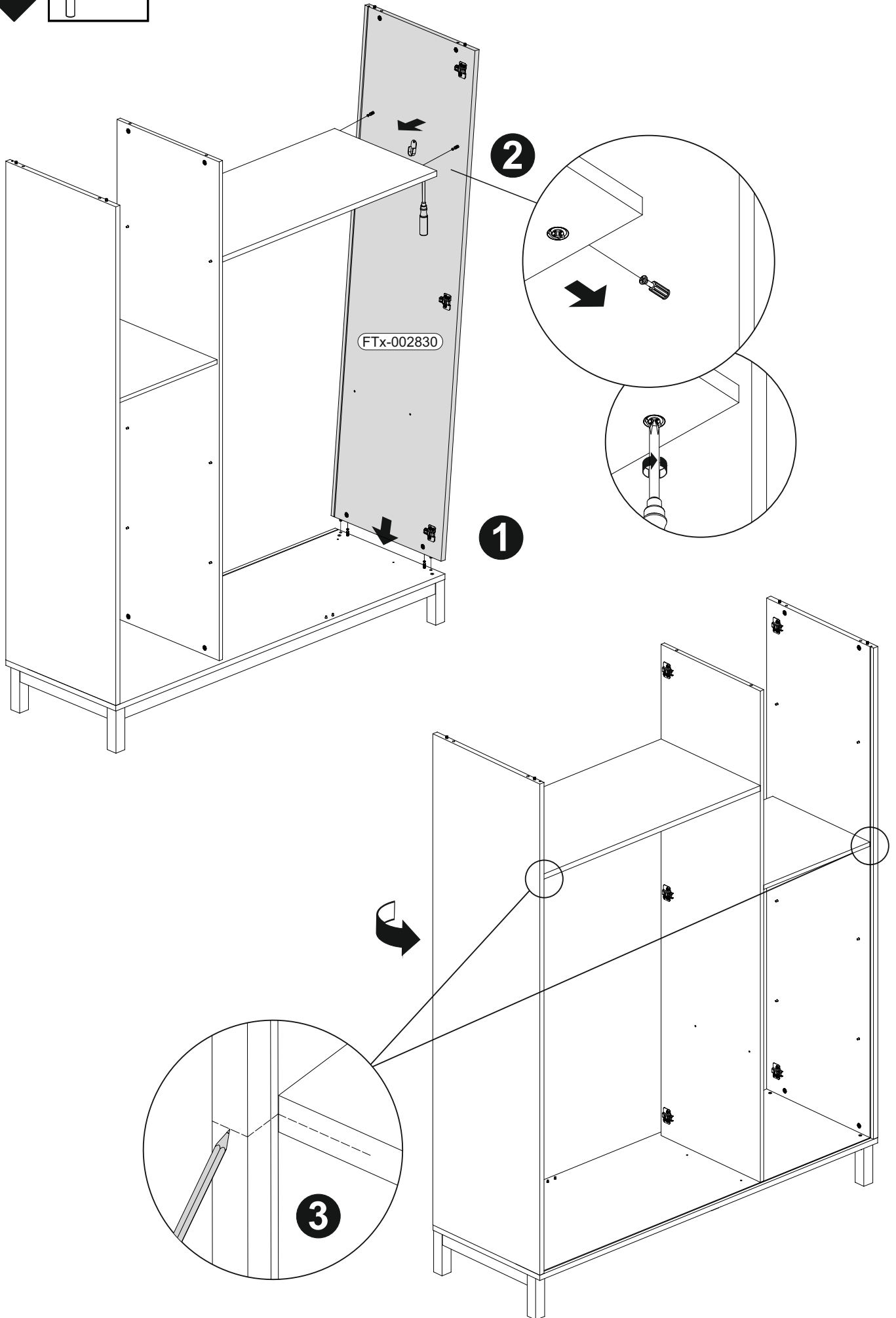
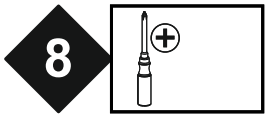

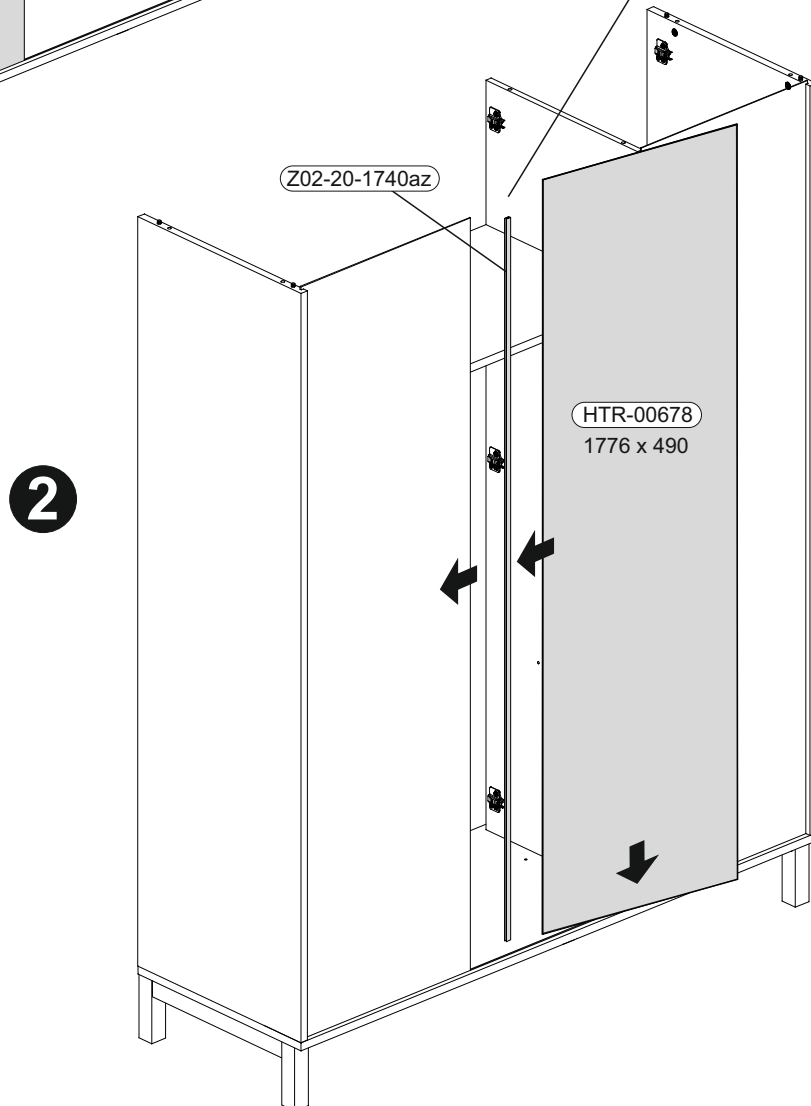
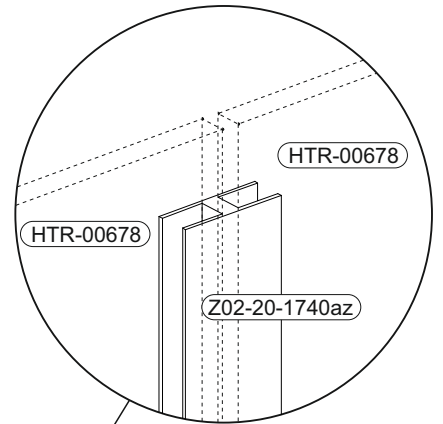
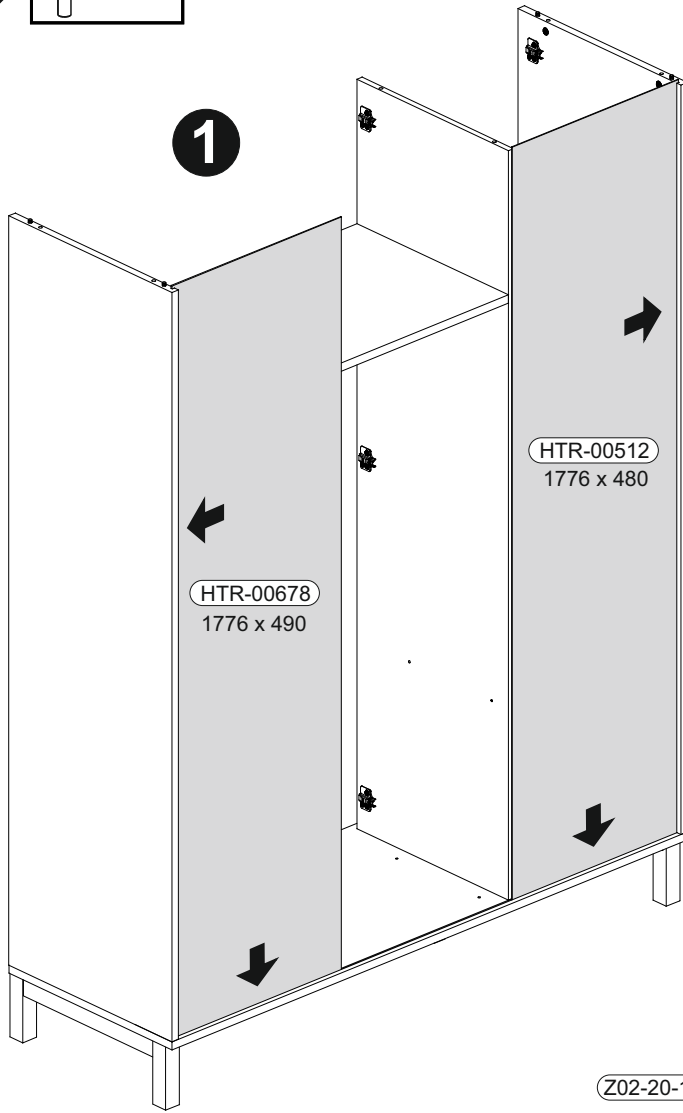
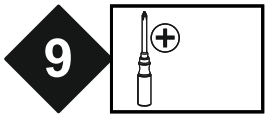

10

	B01-30		B05-185		B01-90	
27x		3x16	6x		6x	3,5x20

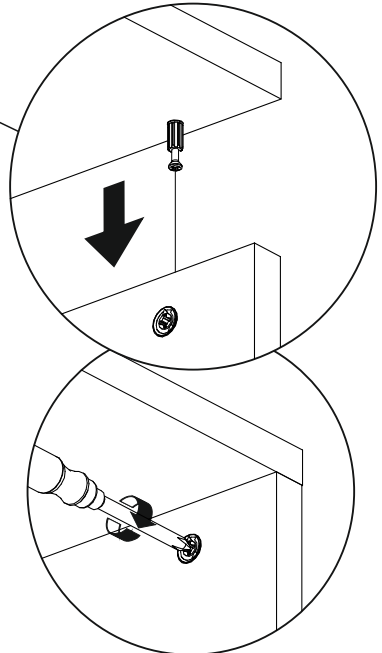
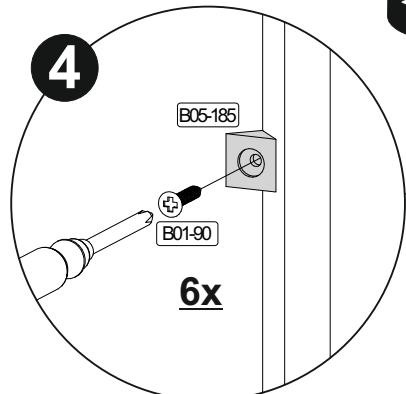
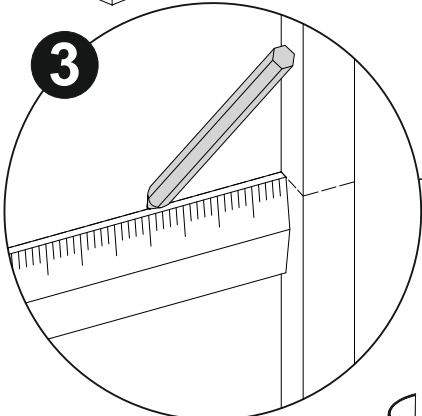
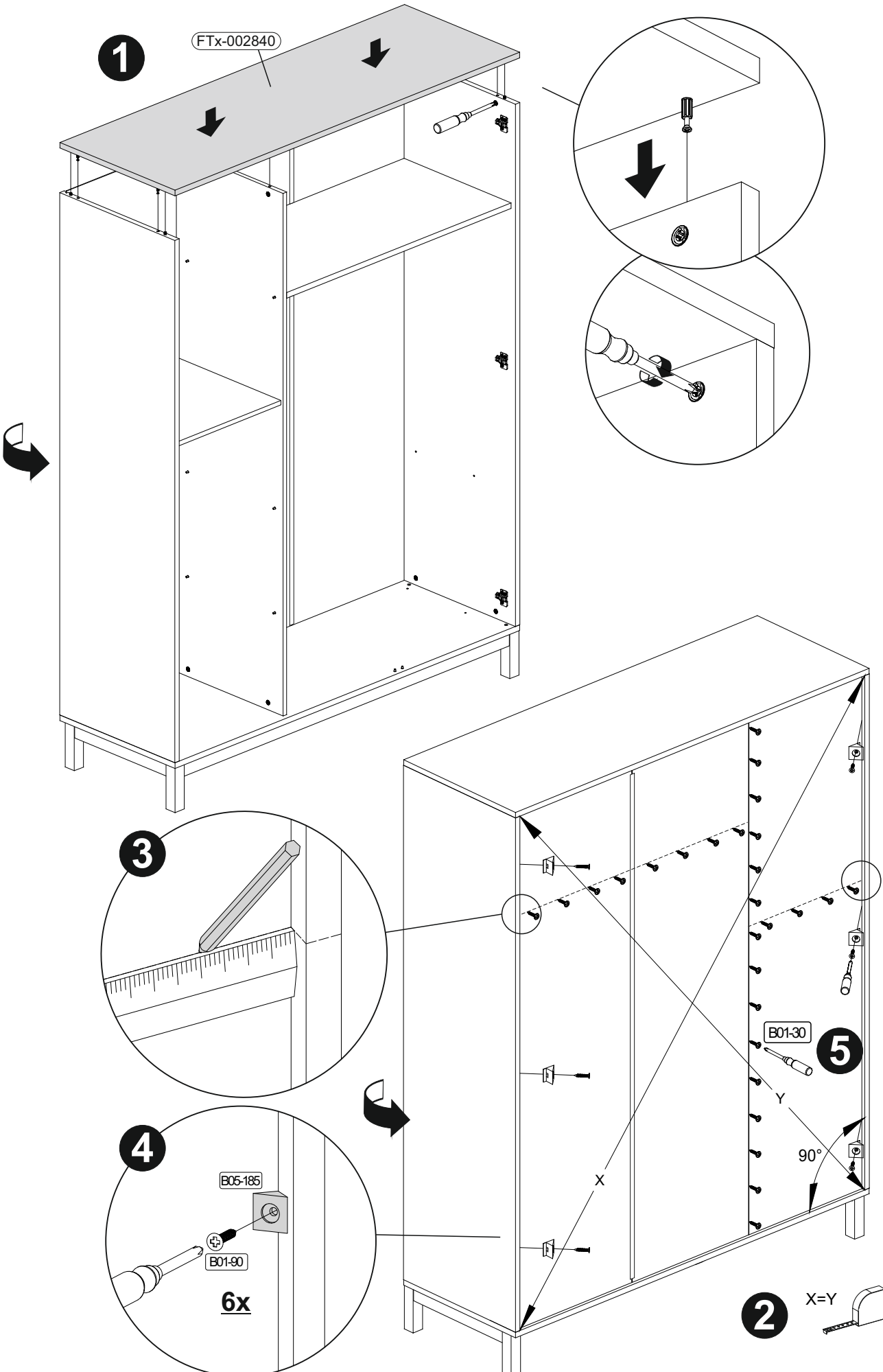

11

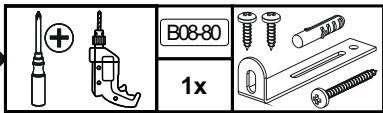

1

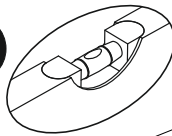

2

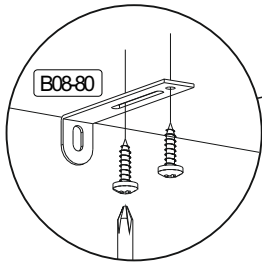

3

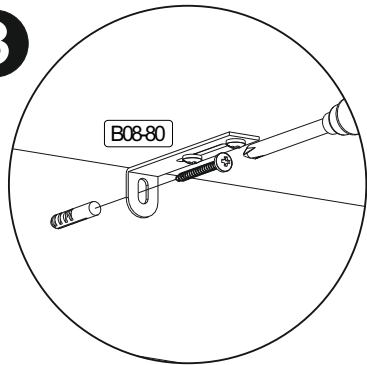



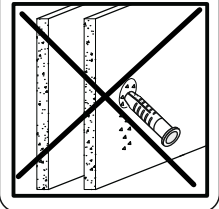
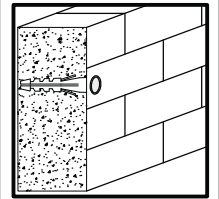
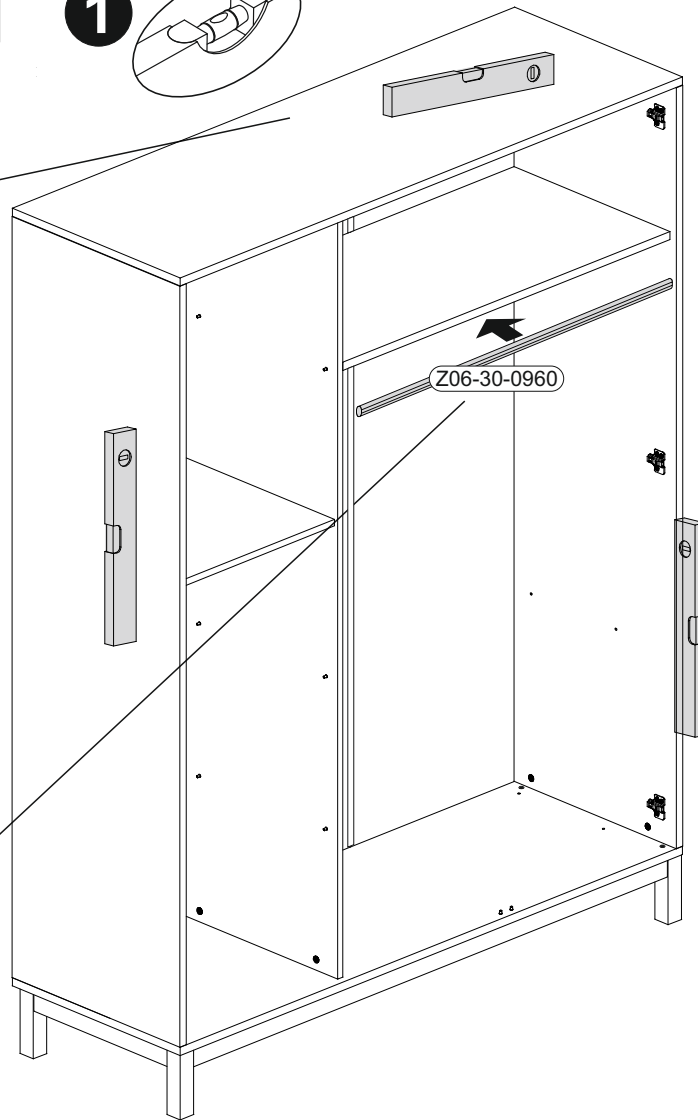
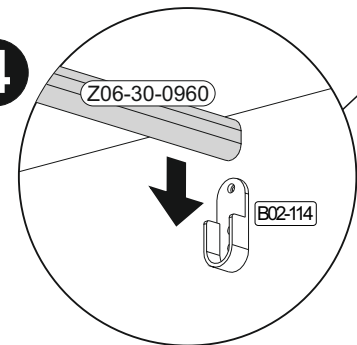



4

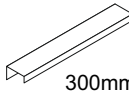

Achtung • Attention • Attenzione • Opgelet • Uwaga • Pozor • Figyelem • Atenție • Dikkat • Внимание • Fara • Vaara • Fare • Peligro	
(D)	Wandbefestigung dient als Kippschutz - unbedingt anbringen! Bei einigen Wandtypen kann ein Spezialdübel erforderlich sein!
(GB)	The wall fastening serves to prevent tipping - be absolutely sure to mount it! For certain wall types, a special wall plug may be necessary!
(FR)	La fixation murale sert de protection contre le basculement – à installer impérativement ! Pour certains types de murs il faut des chevilles spéciales !
(TR)	Duvardaki sabitleme, devrilmeye karşı bir emniyet tedbiridir ve mutlaka monte edilmelidir! Bazı duvar tiplerinde bunun için özel bir dübel gerekli olabilir!
(IT)	Il fissaggio alla parete serve da protezione anti-ribaltamento – attaccarla assolutamente! Per alcune strutture di parete può essere necessario un tassello speciale!
(NL)	Bevestiging aan de muur dient als kantelbescherming – zeker en vast bevestigen! Bij enkele muurtypes is een speciale plug misschien vereist!
(RU)	Обязательно установите крепление на стене во избежание опрокидывания! Для некоторых типов стен может потребоваться специальный дюбель!
(CZ)	Montáž na stěnu slouží jako ochrana proti převrnutí – bezpodmínečně umístěte! U některých typů stěn může být zapotřebí speciální hmoždinka!
(HU)	A termék a falhoz kel rögzítési, különben az felborulhat! Egyes faltípusoknál speciális tiplit kell használni!
(RO)	Sistemul de fixare la perete servește ca protecție la răsturnare - de montat obligatoriu! Pentru unele tipuri de pereți este posibil să fie necesar un diblu special!
(PL)	Mocowanie do ściany jest jednocześnie zabezpieczeniem przed przewróceniem – koniecznie zamontować! Do niektórych rodzajów ścian koniecznie zastosować specjalne kołki mocujące.
(SWE)	Väggmontering fungerar som anti-lutningskydd - det är viktigt att fästa det! En speciell plugg kan behövas för vissa väggtyper!
(FIN)	Seinäkiinnitys toimii kaatumista estävänä suojana - se on ehdottomasti kiinnitettävä! Joihinkin seinätyyppeihin voidaan tarvita erityistappi!
(NOR)	Veggmontering fungerer som anti-vippebeskyttelse - det er viktig å feste det! En spesiell dyvel kan være nødvendig for noen veggtyper!
(DAN)	Vægmontering fungerer som anti-vip beskyttelse - det er vigtigt at fastgøre det! En speciel dyvel kan være påkrævet til nogle vægtyper!
(SK)	Upevnenie na stenu slúži ako ochrana proti prevráteniu – bezpodmienečne použite! Pre niektoré druhy stien môže byť potrebná špeciálna hmoždinka!
(ES)	El montaje en la pared sirve como protección antivuelco: ¡es imprescindible fijarlo! ¡Es posible que se requiera una espiga especial para algunos tipos de paredes!

12

	B03-03 3x		B06-423 1x		300mm	B01-200 2x		6,3x13 6x	B01-80 6x		3,5x13 2x	B03-130 2x	
--	--------------	--	---------------	--	-------	---------------	--	--------------	--------------	--	--------------	---------------	--

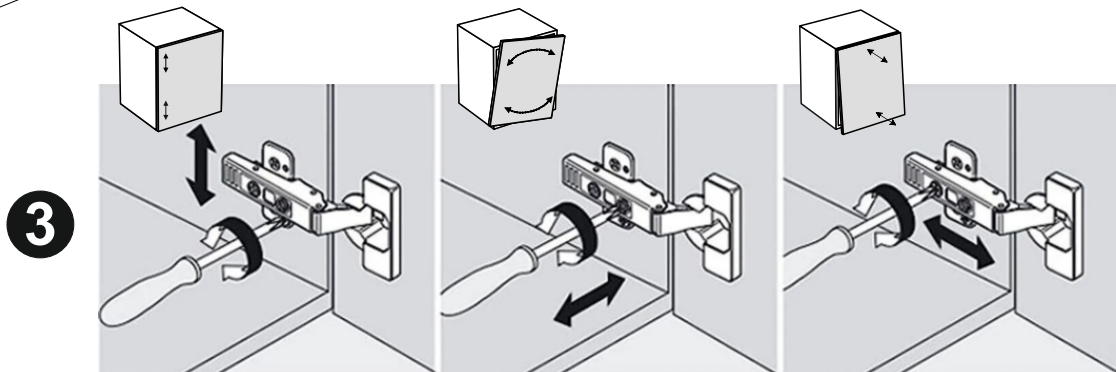
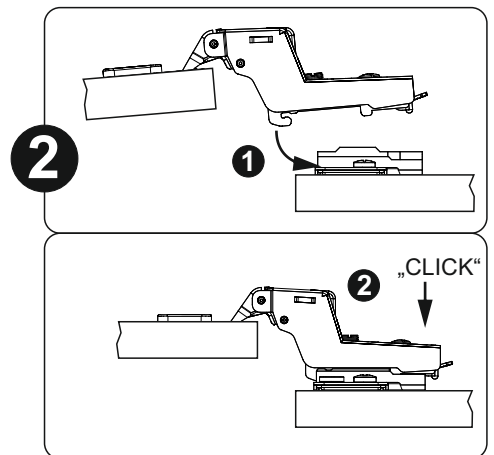
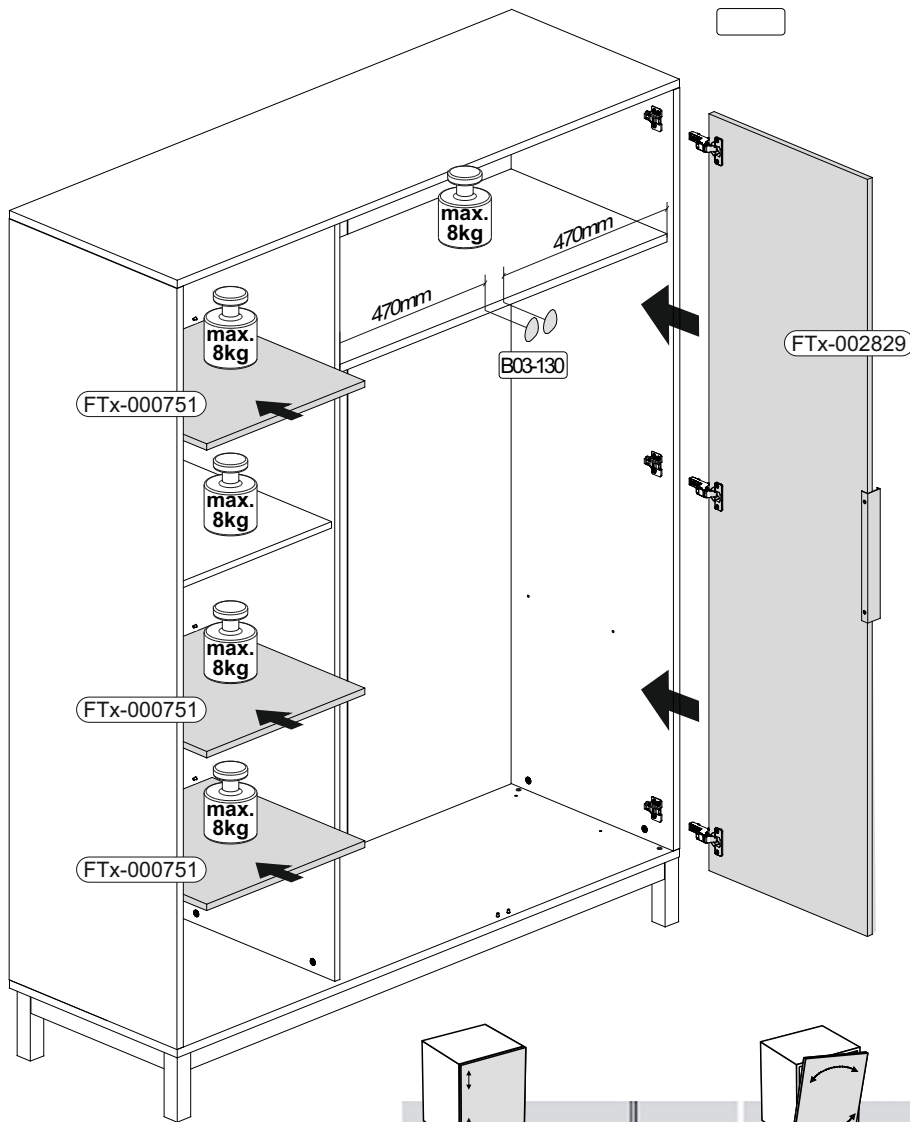
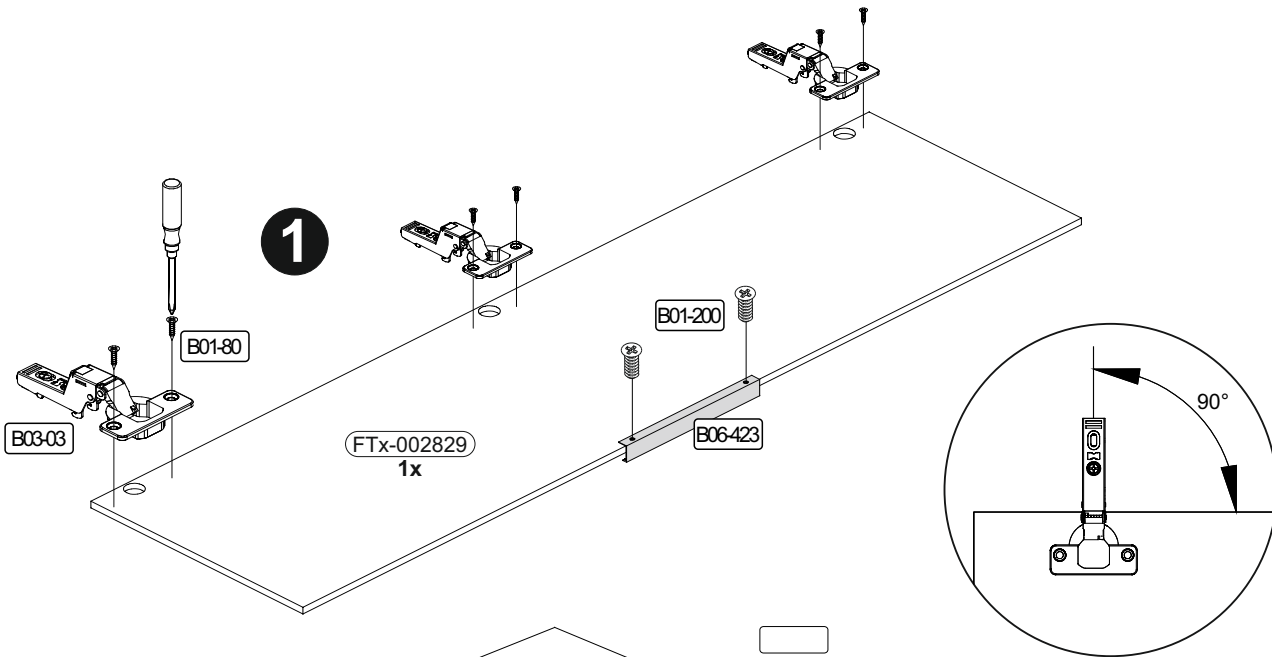

13

	B03-03		B06-423		B01-200		B01-80		B03-130	
	3x		1x	300mm	2x	6,3x13	6x	3,5x13	2x	

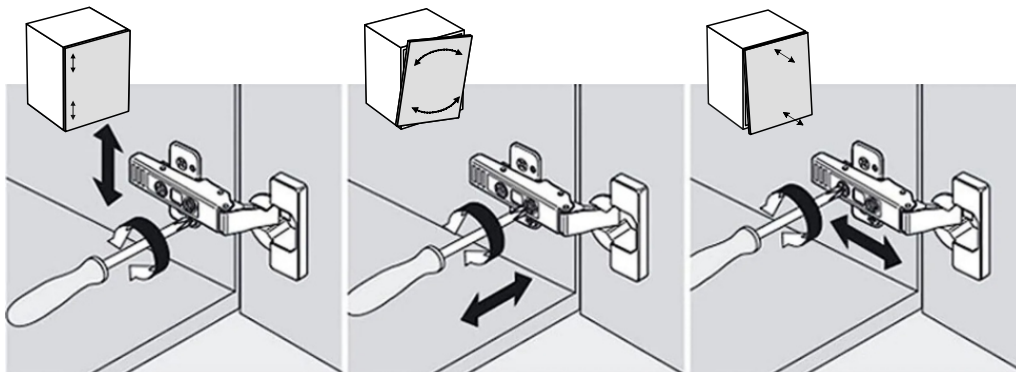
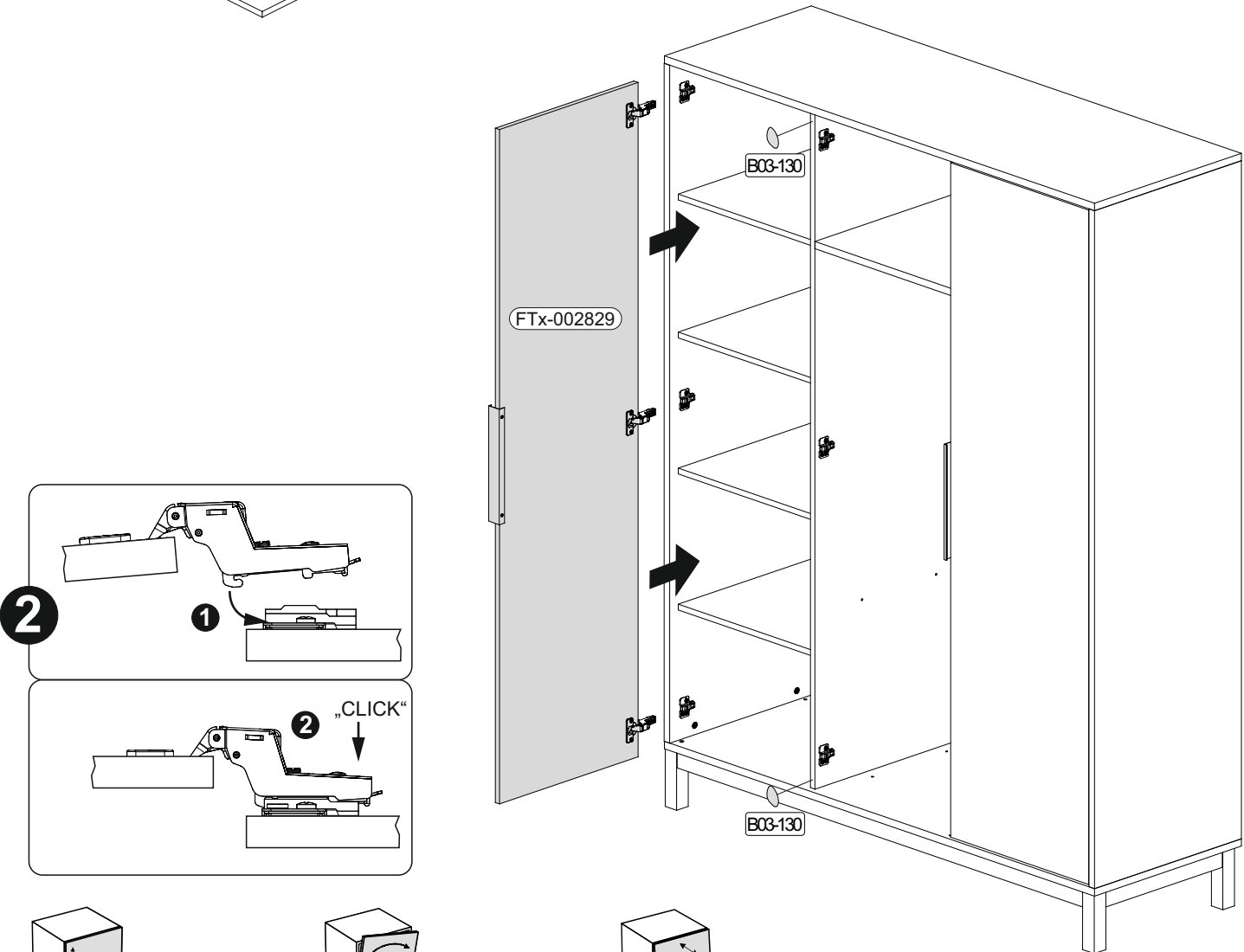
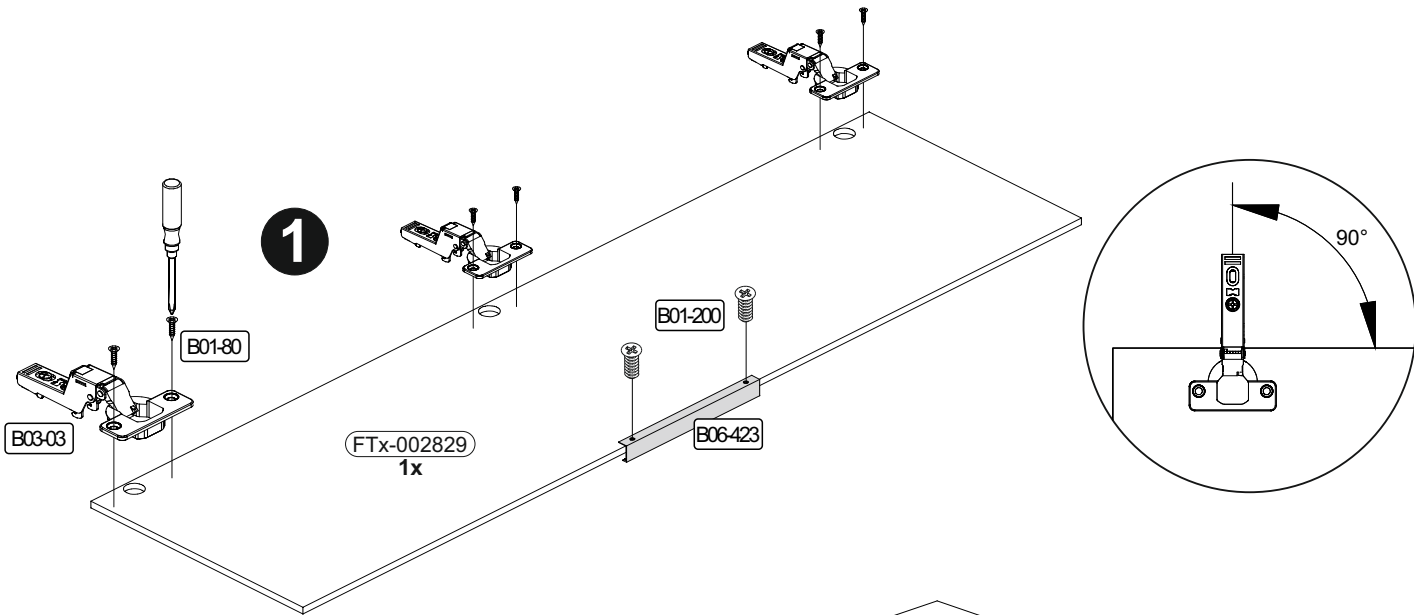

14

	B03-03		B01-80	
	3x		6x	3,5x13

