

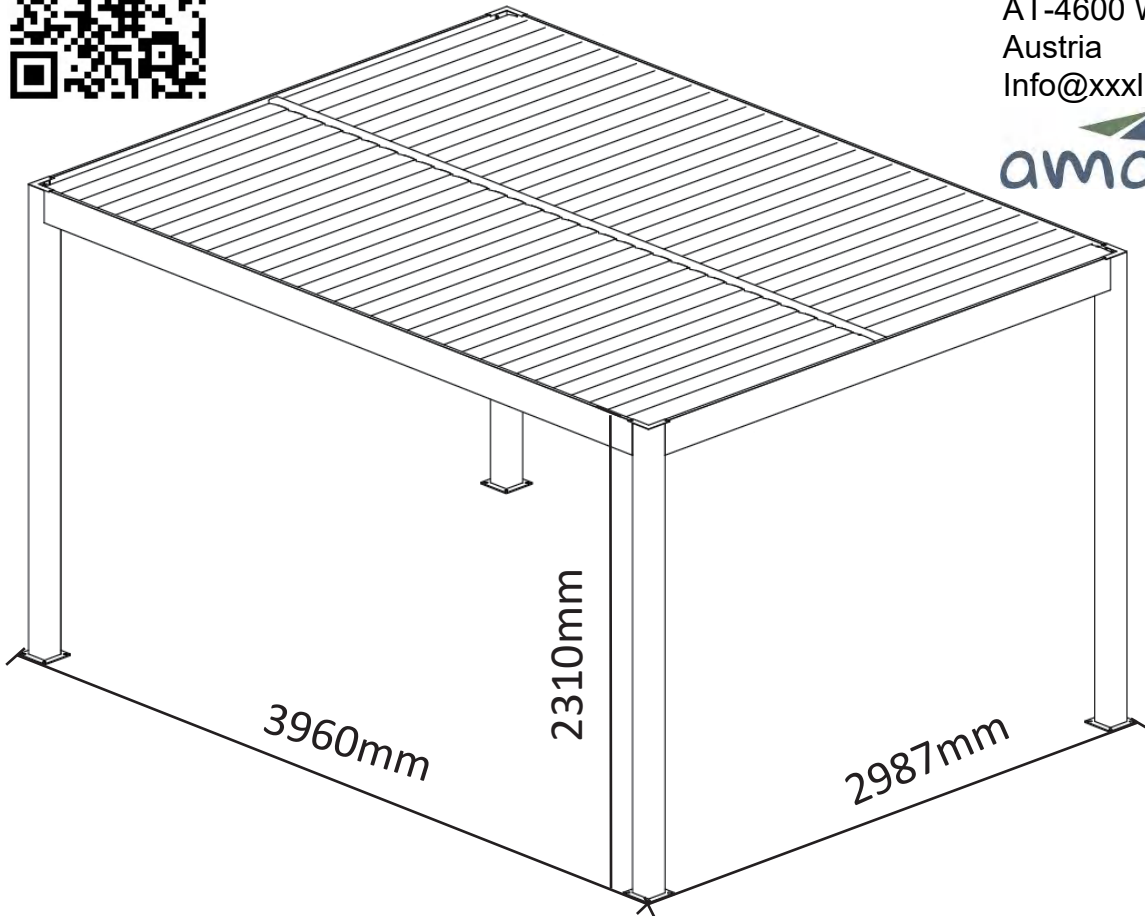

06390087/01







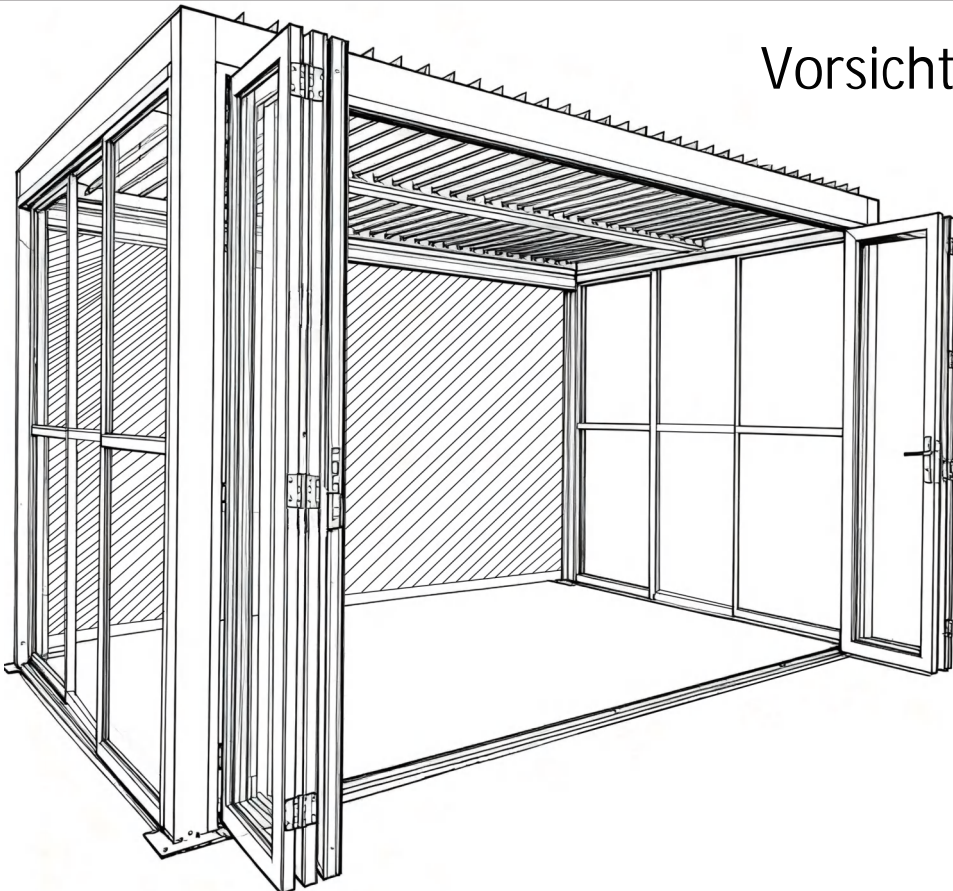

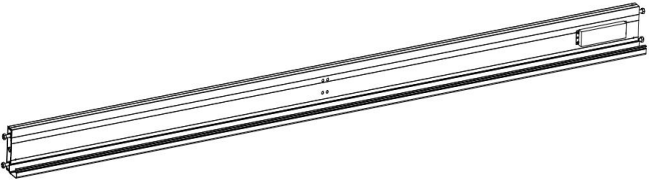
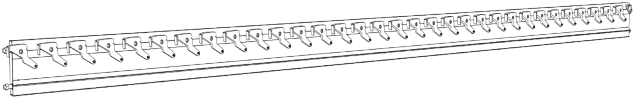
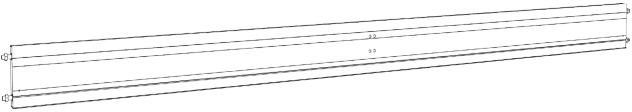
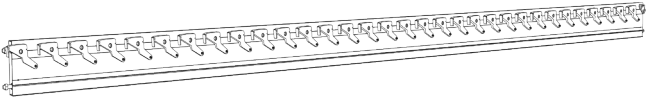
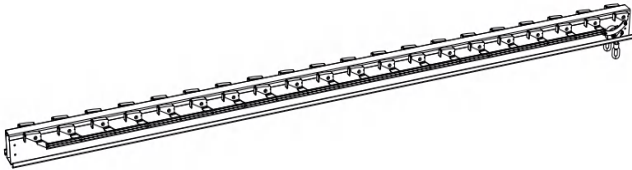
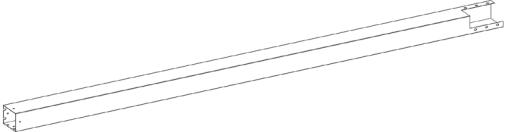
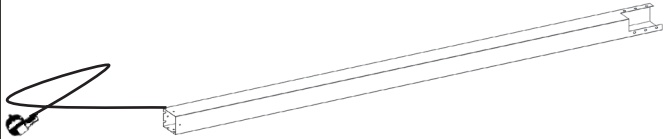
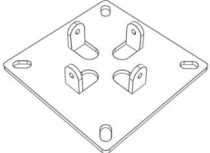
XXXLutz KG  
Roemerstrasse 39  
AT-4600 Wels  
Austria  
Info@xxxlutz.at

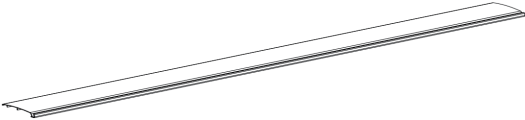

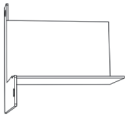







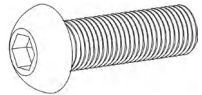
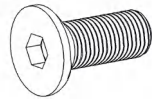

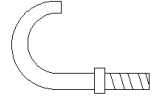
Vorsicht Glas!

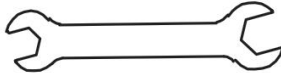

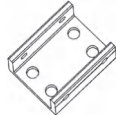
		<b>qty</b>
<b>A</b>		<b>1</b>
<b>B</b>		<b>1</b>
<b>C</b>		<b>1</b>
<b>D</b>		<b>1</b>
<b>E</b>		<b>1</b>
<b>F</b>		<b>3</b>
<b>G</b>		<b>1</b>
<b>H</b>		<b>4</b>

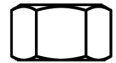
		qty
I		64
J		2
K		4
L		2
M		1
N		1
O		1
P		1
Q		1

AA		M4*13mm	21
BB		M6*20mm	9
CC		M6*16mm	25
DD		M10*100mm	17
EE		M6	1
FF		\	2
		\	1
		\	1
GG		\	2
HH		M10	16
II		M10	16
JJ		M10	16
KK		\	4

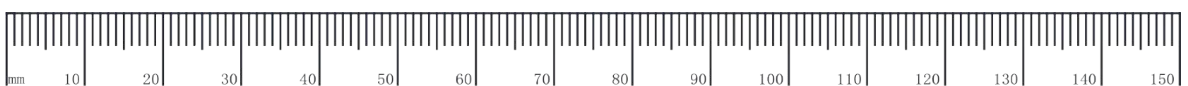



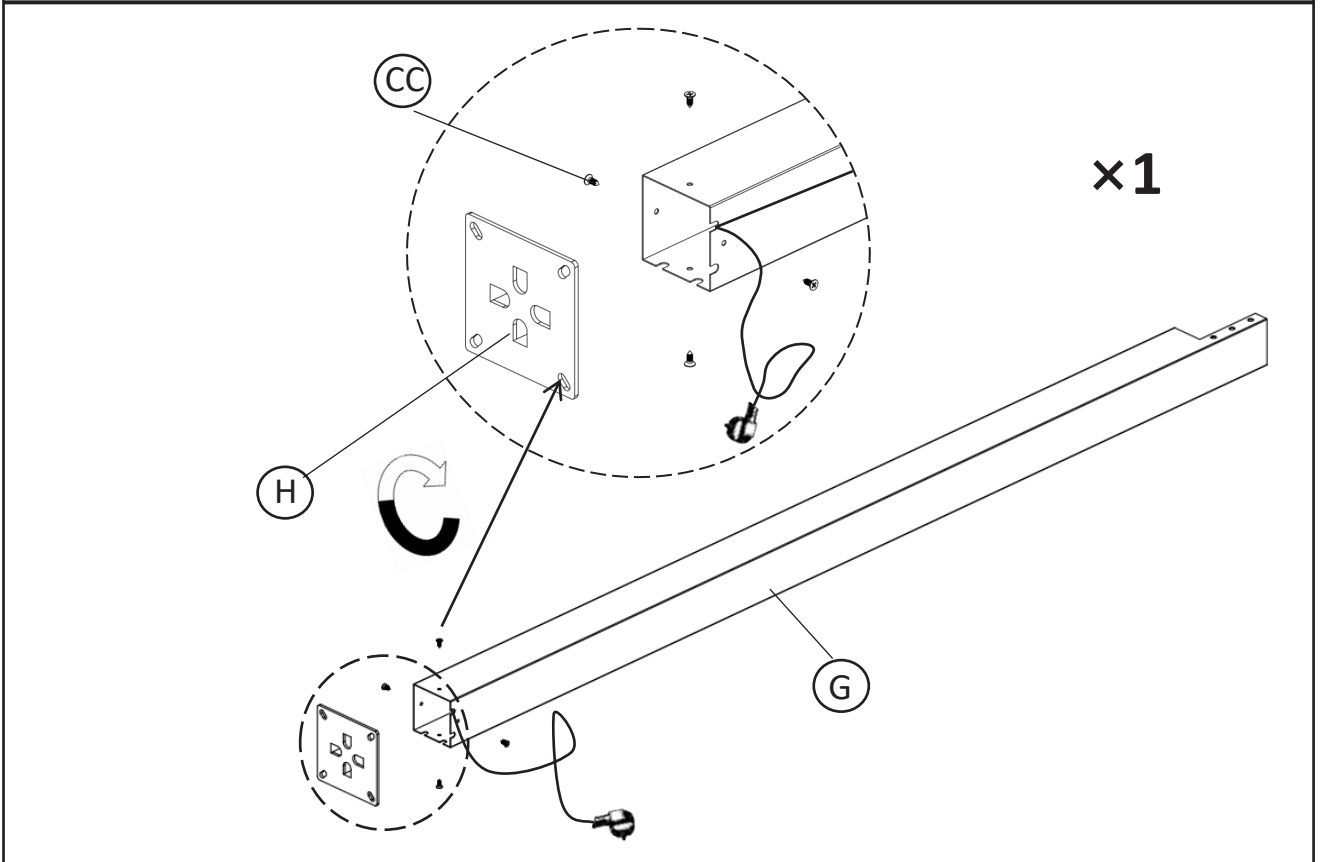
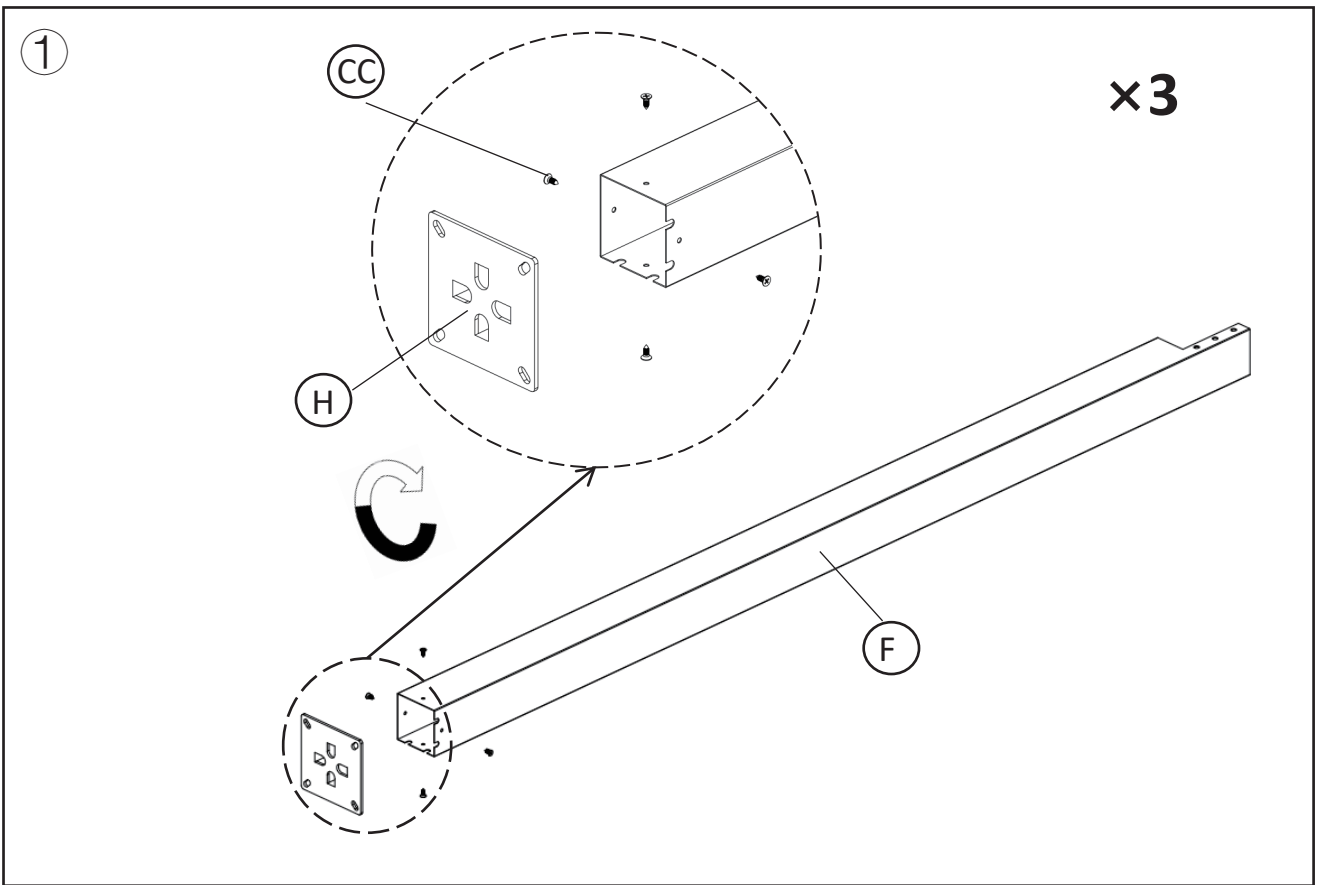

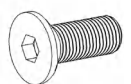
X 2hours



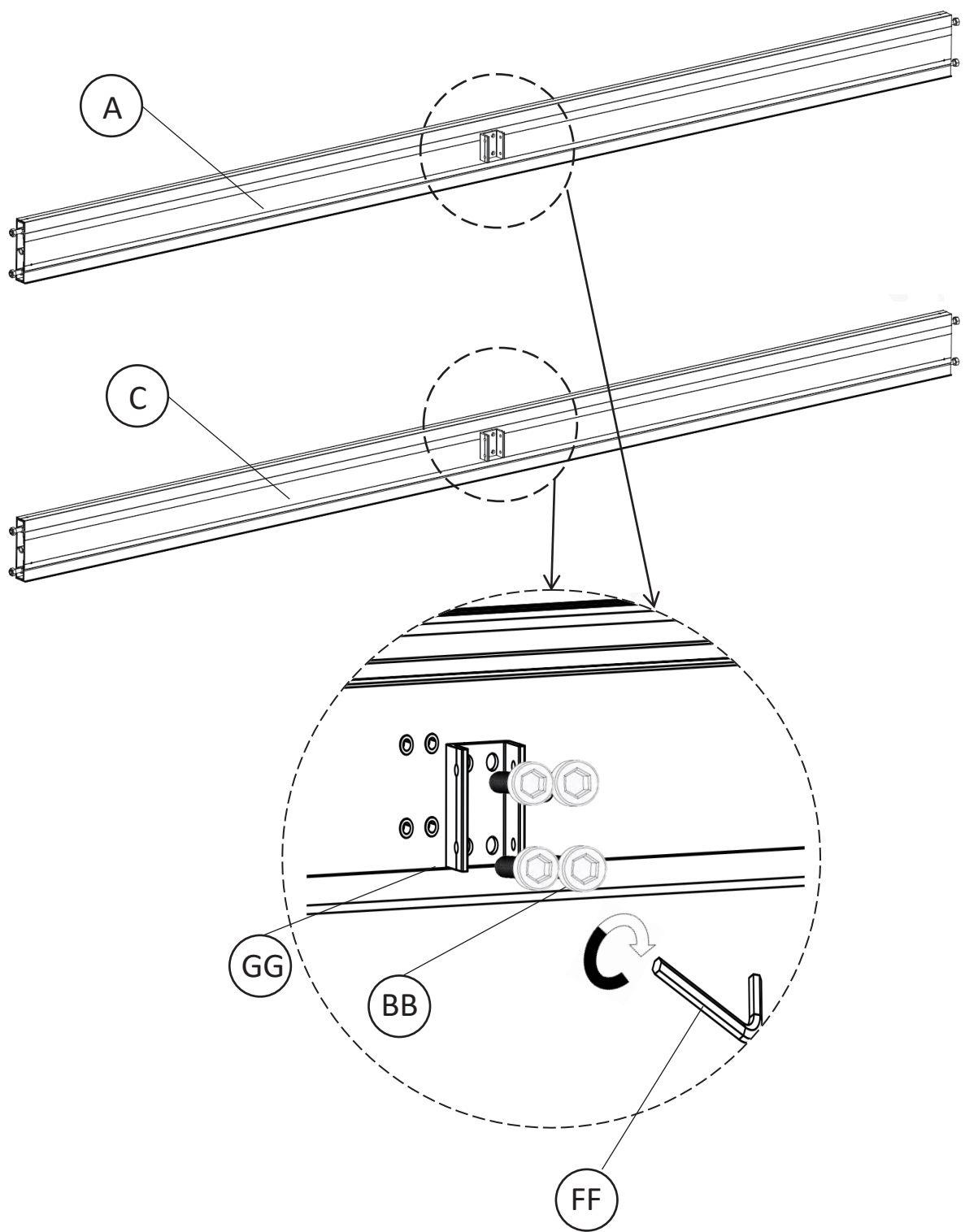



H		200*200*5mm	4
CC		M6*16mm	×16

2

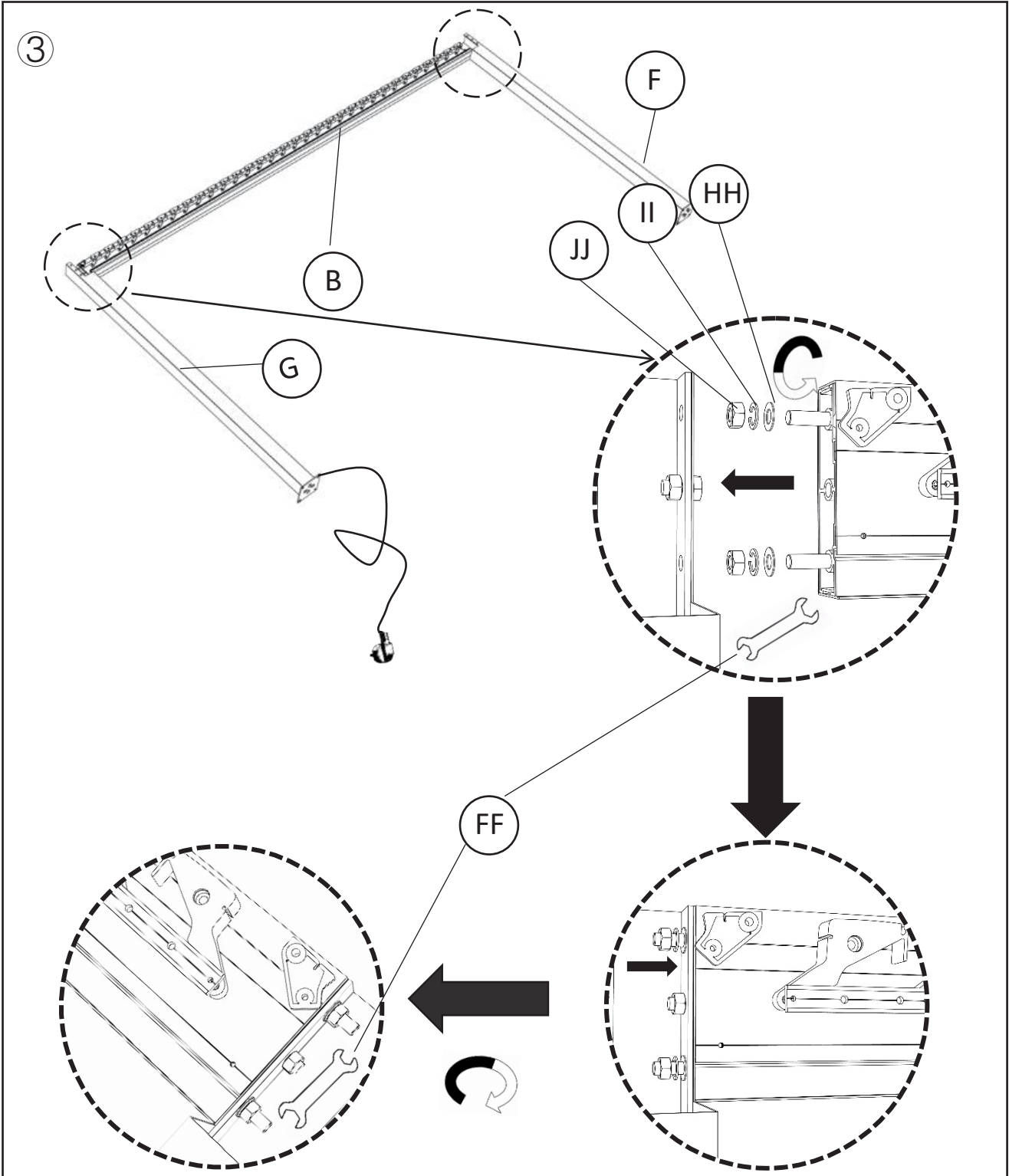

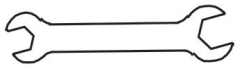



GG		\	×2
FF		\	×2
BB		M6*20 mm	×8

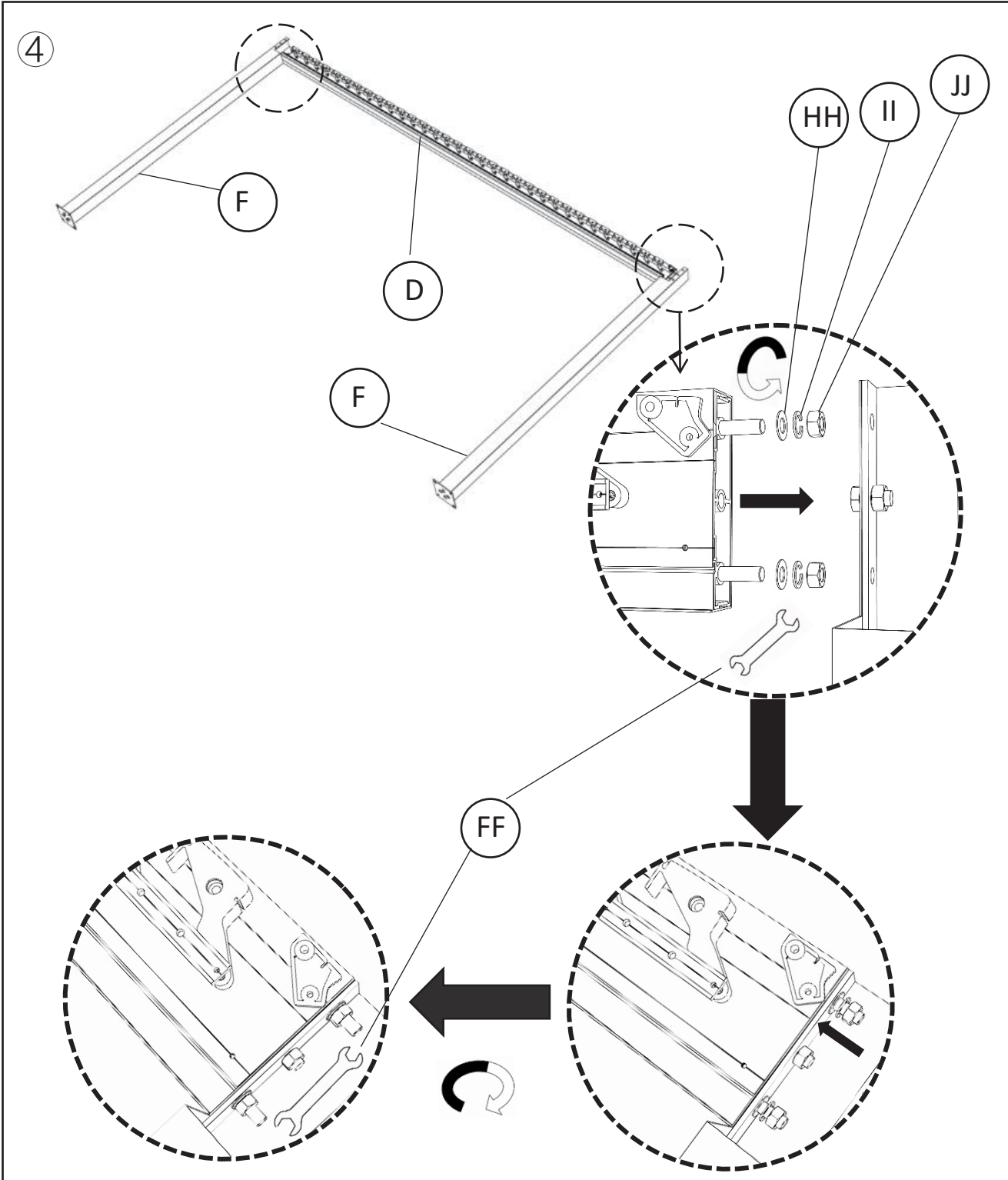

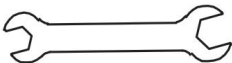



FF		\	×1
HH		M10	×4
II		M10	×4
JJ		M10	×4

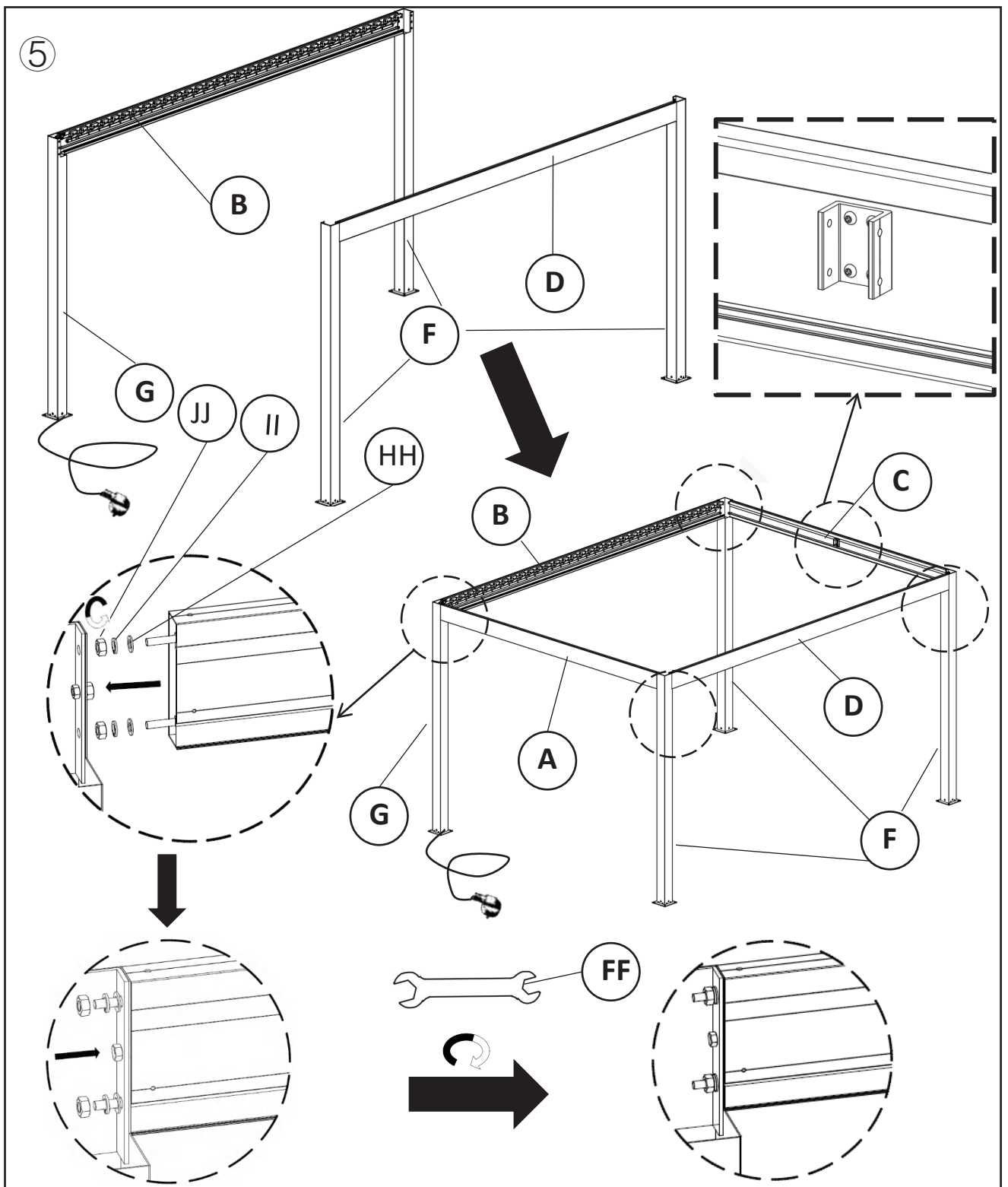

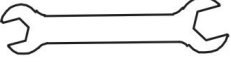
FF		\	×1
HH		M10	×4
II		M10	×4
JJ		M10	×4



FF		\	×1
HH		M10	×8
II		M10	×8
JJ		M10	×8

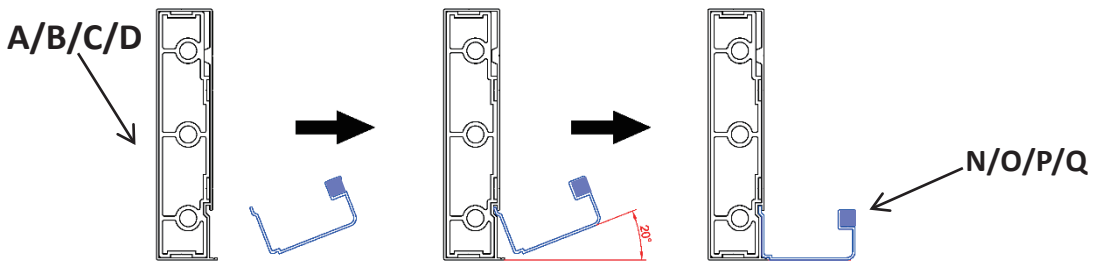
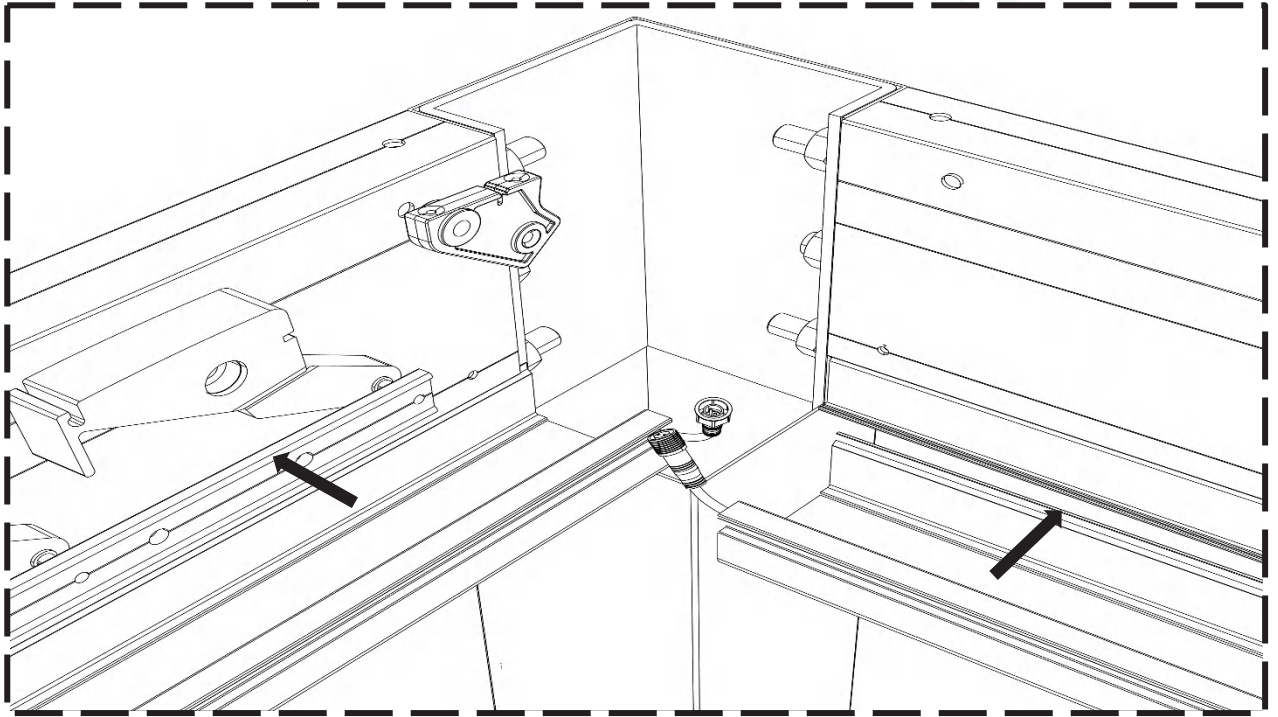
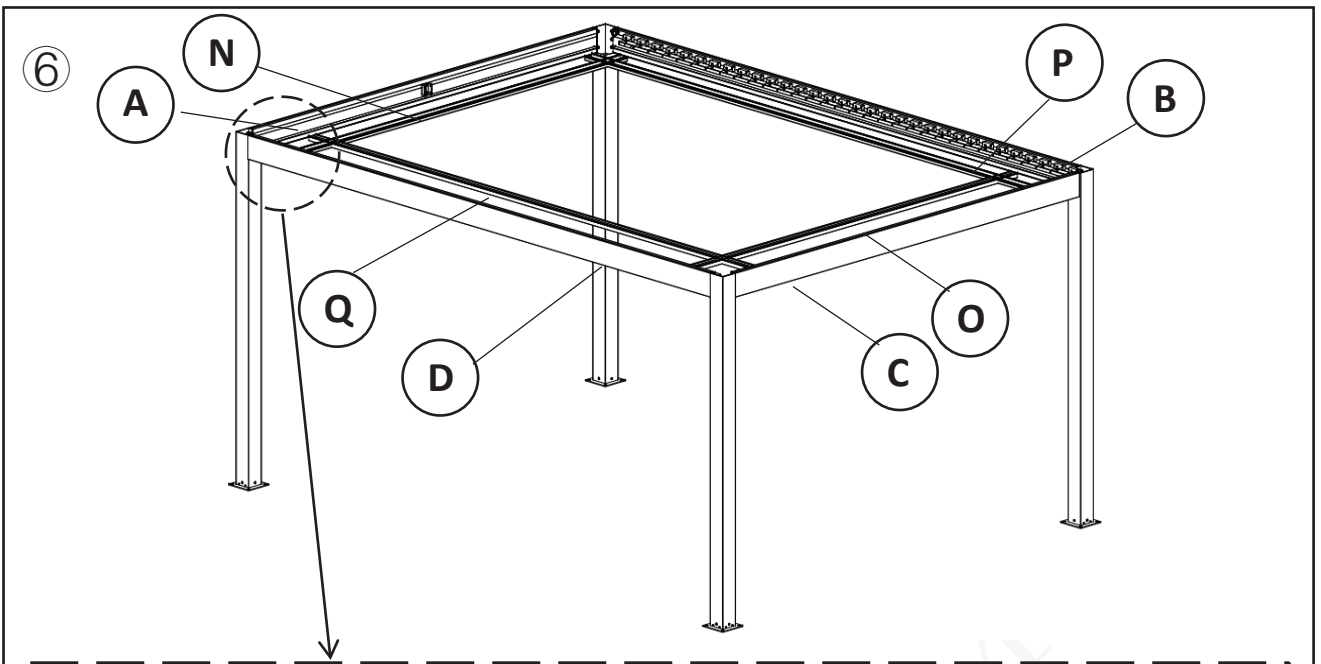

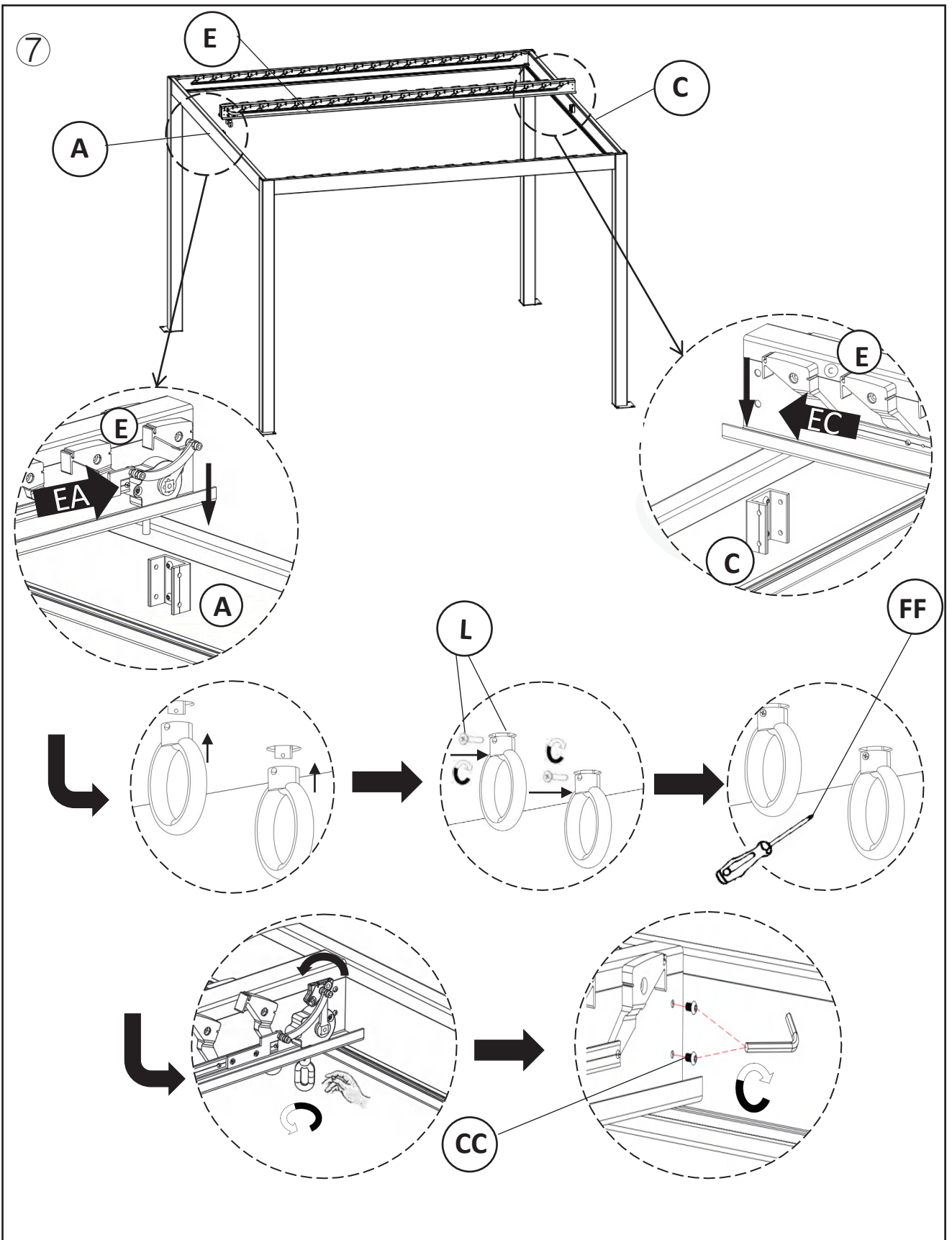

N	O		\	×1/×1
P	Q		\	×1/×1

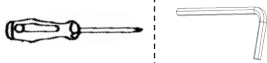
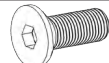

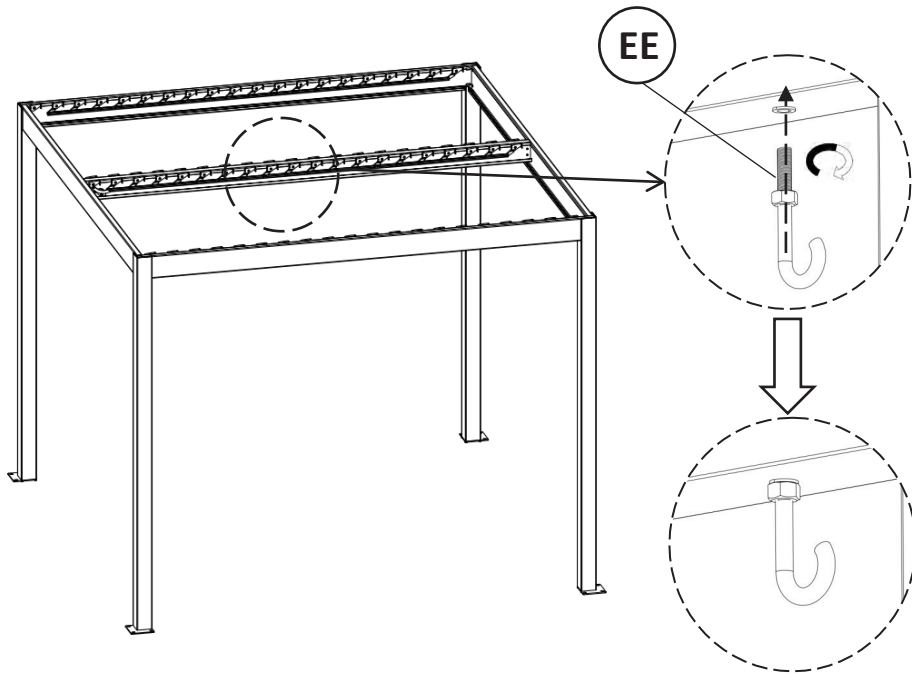
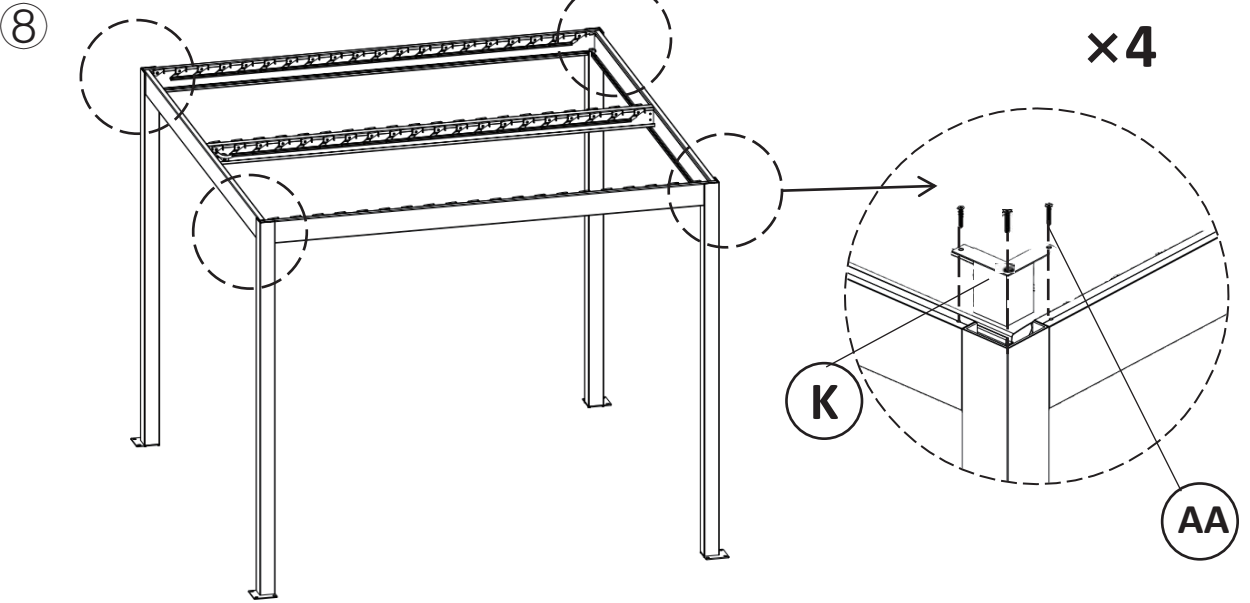
L		M4*20mm	×2
FF		\	×1/×2
CC		M6*16mm	×8



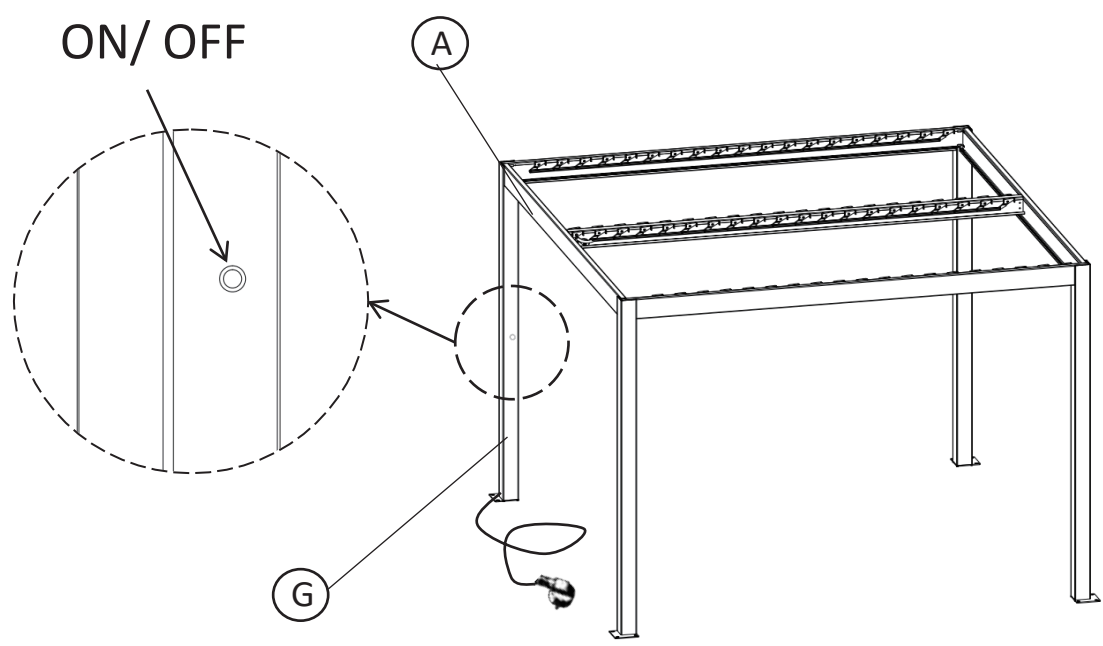
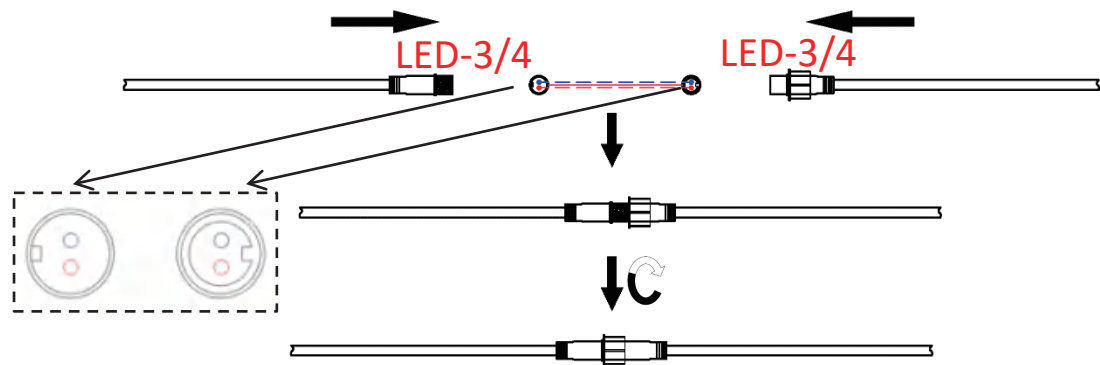
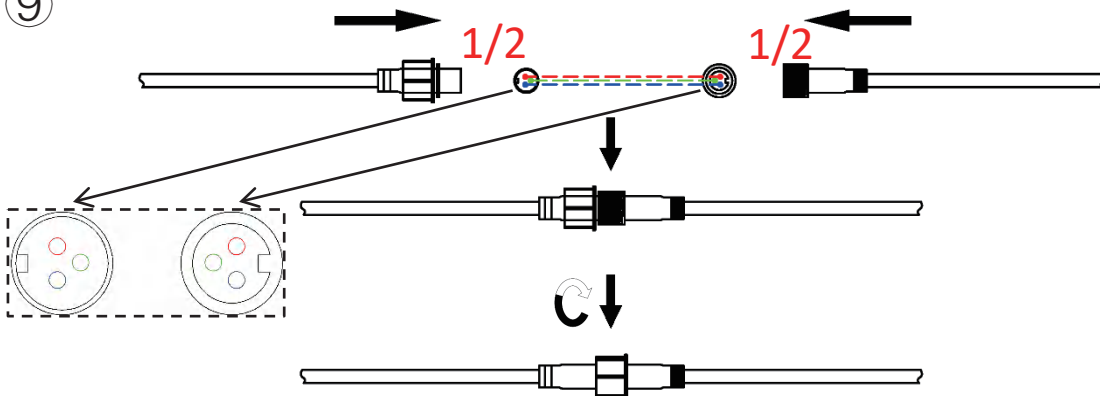

K		\	x4
AA		M4*13mm	x12
EE		M6	x1

9

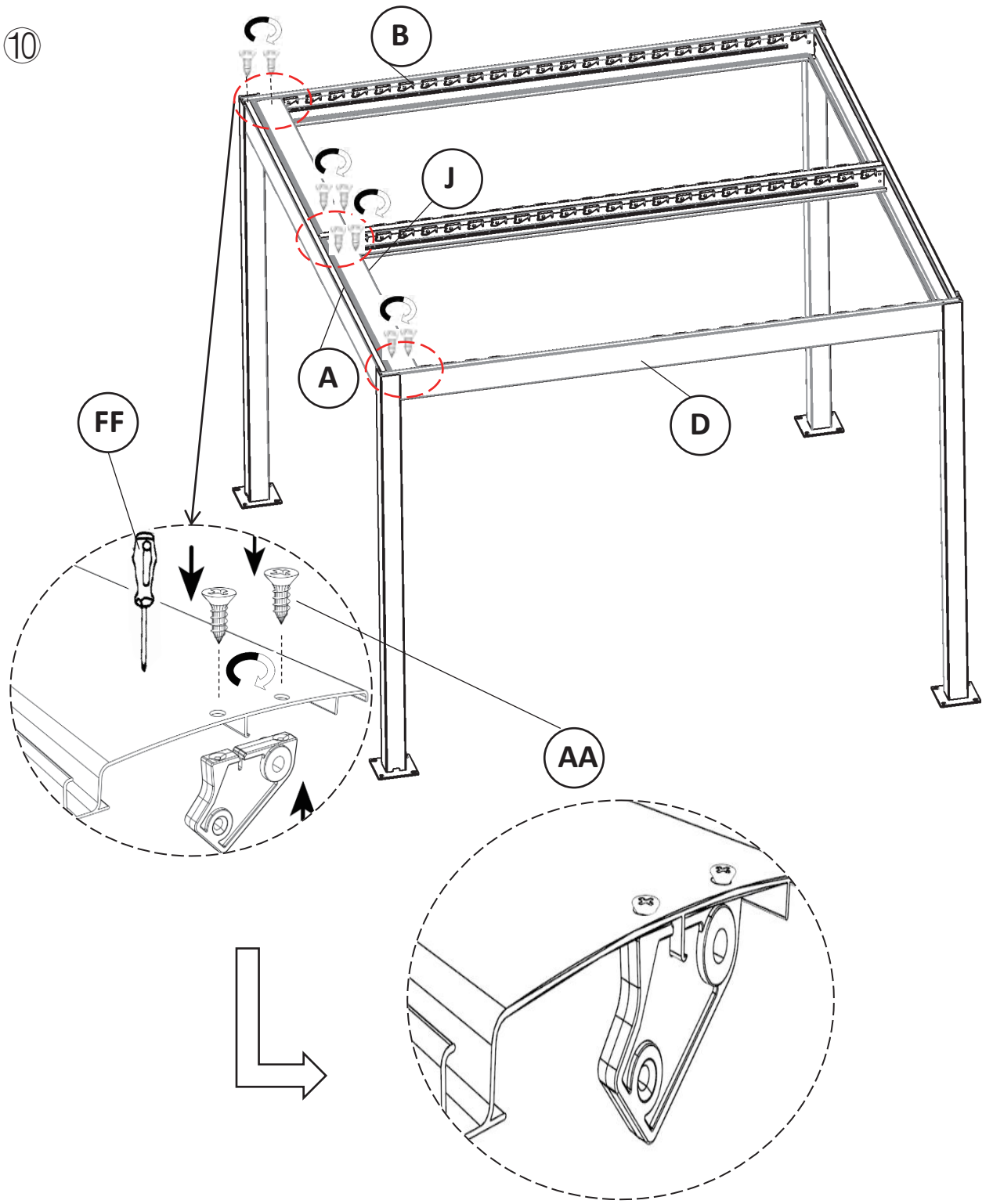

10

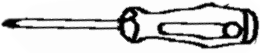

FF		\	×1
AA		M4*13mm	×8
J		\	×2

11

I

J

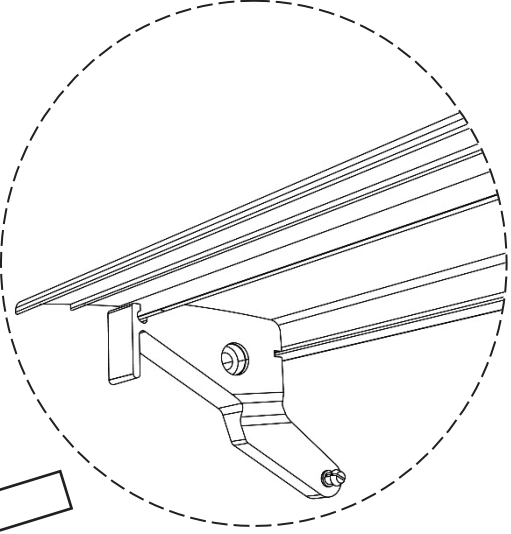
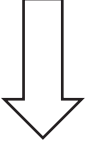
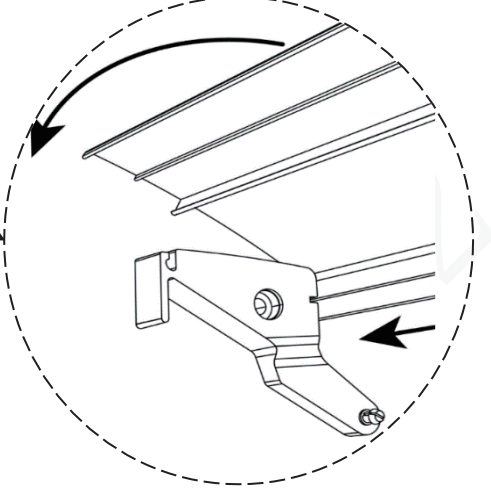
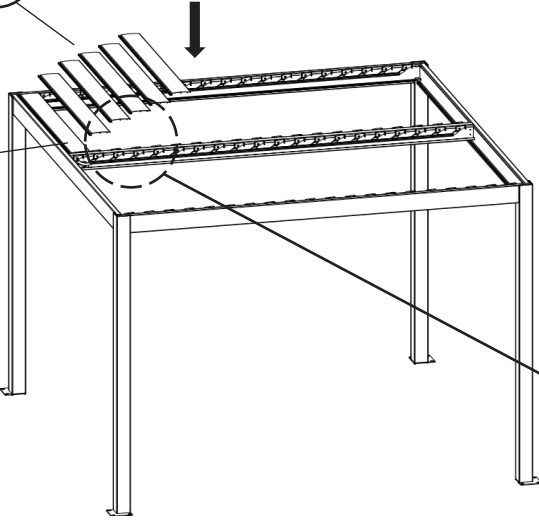

J

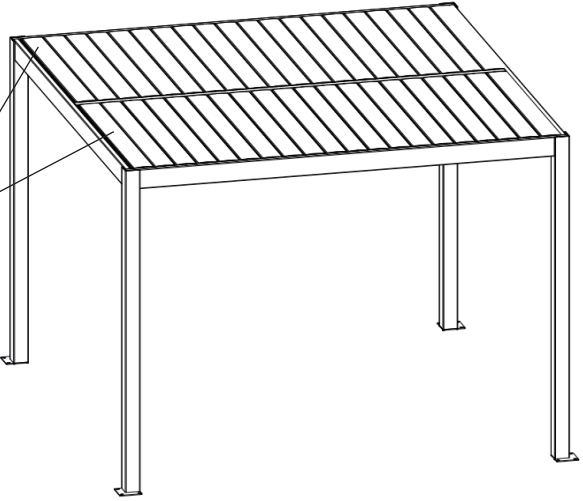

I		I	×64
---	---	---	-----

12

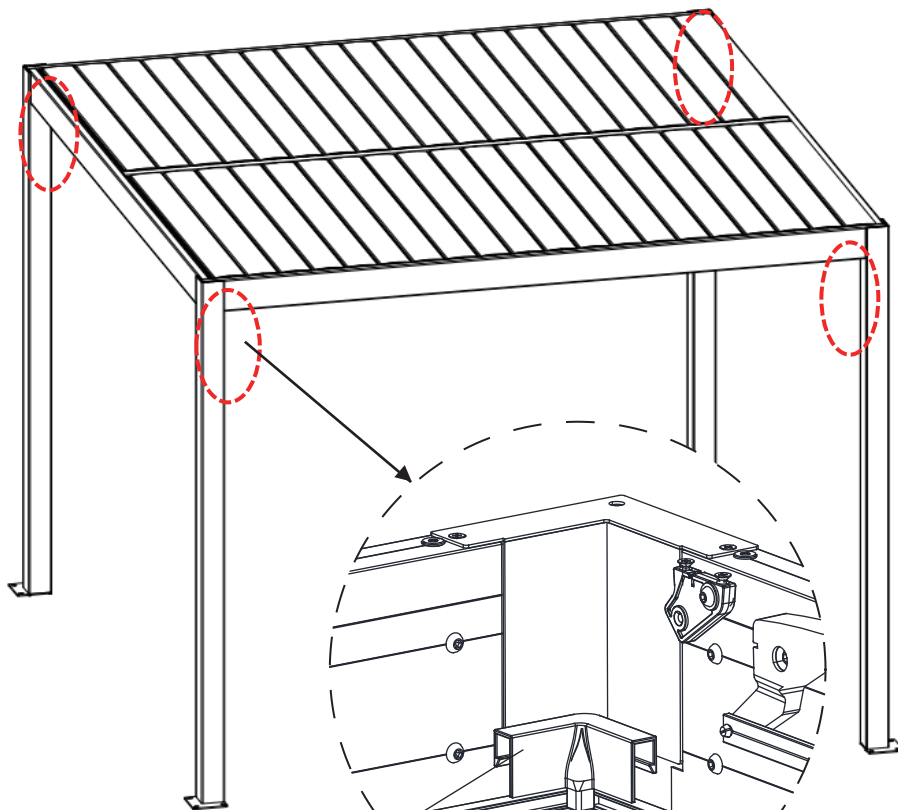

KK

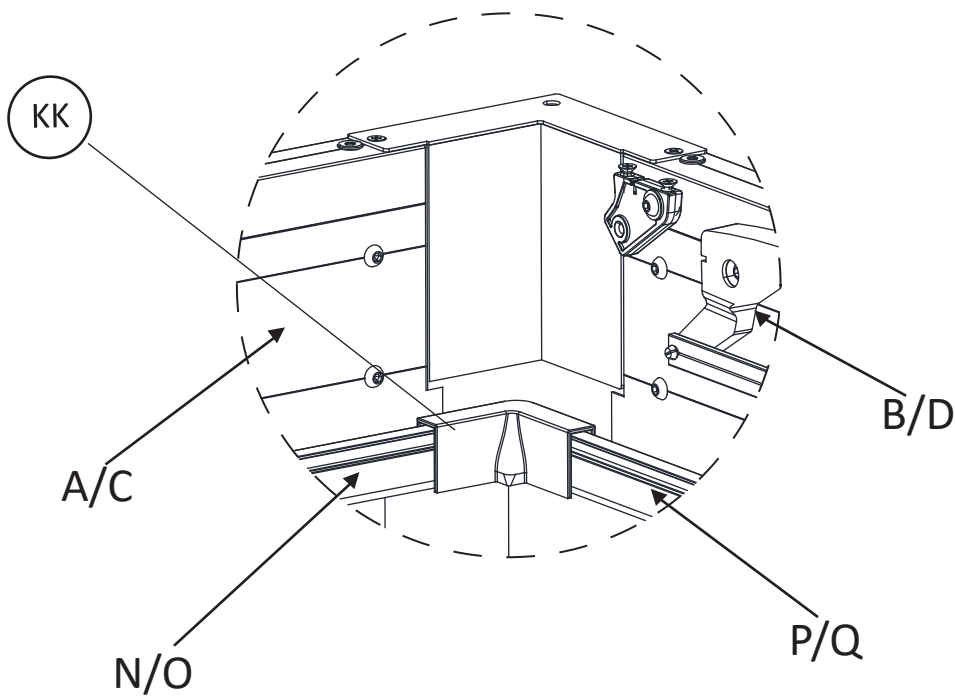





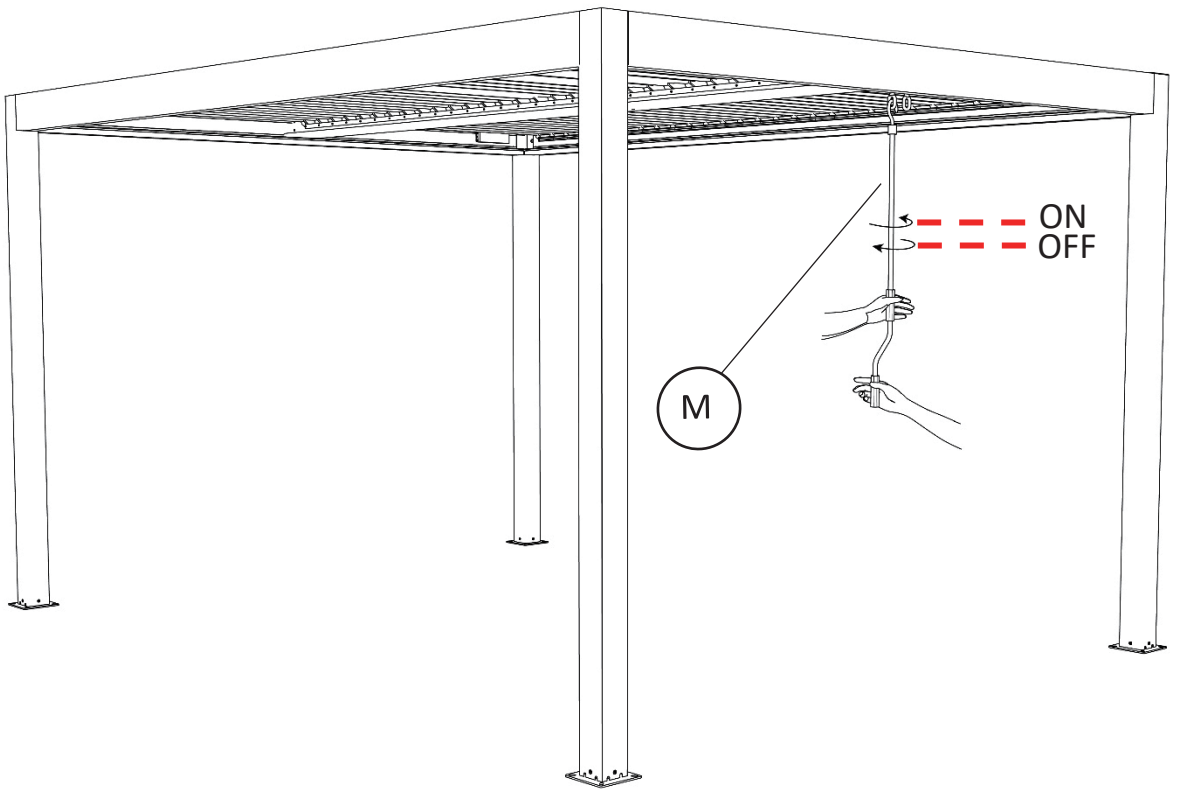



KK		\	×4
----	---	---	----

13





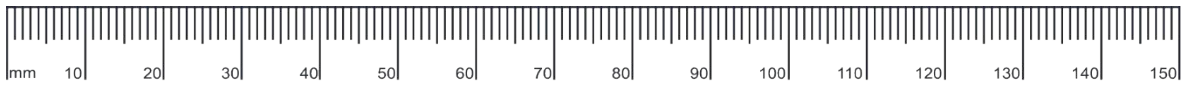

M		\	×1
---	---	---	----

		qty	
3M/4M		1	\
X1+Y1+Z1		1	\
X2+Y2+Z2		1	\
R		1	3mm
S		8	M3.9*16mm
T		8	M4
U		1	\
V		8	M4*25mm

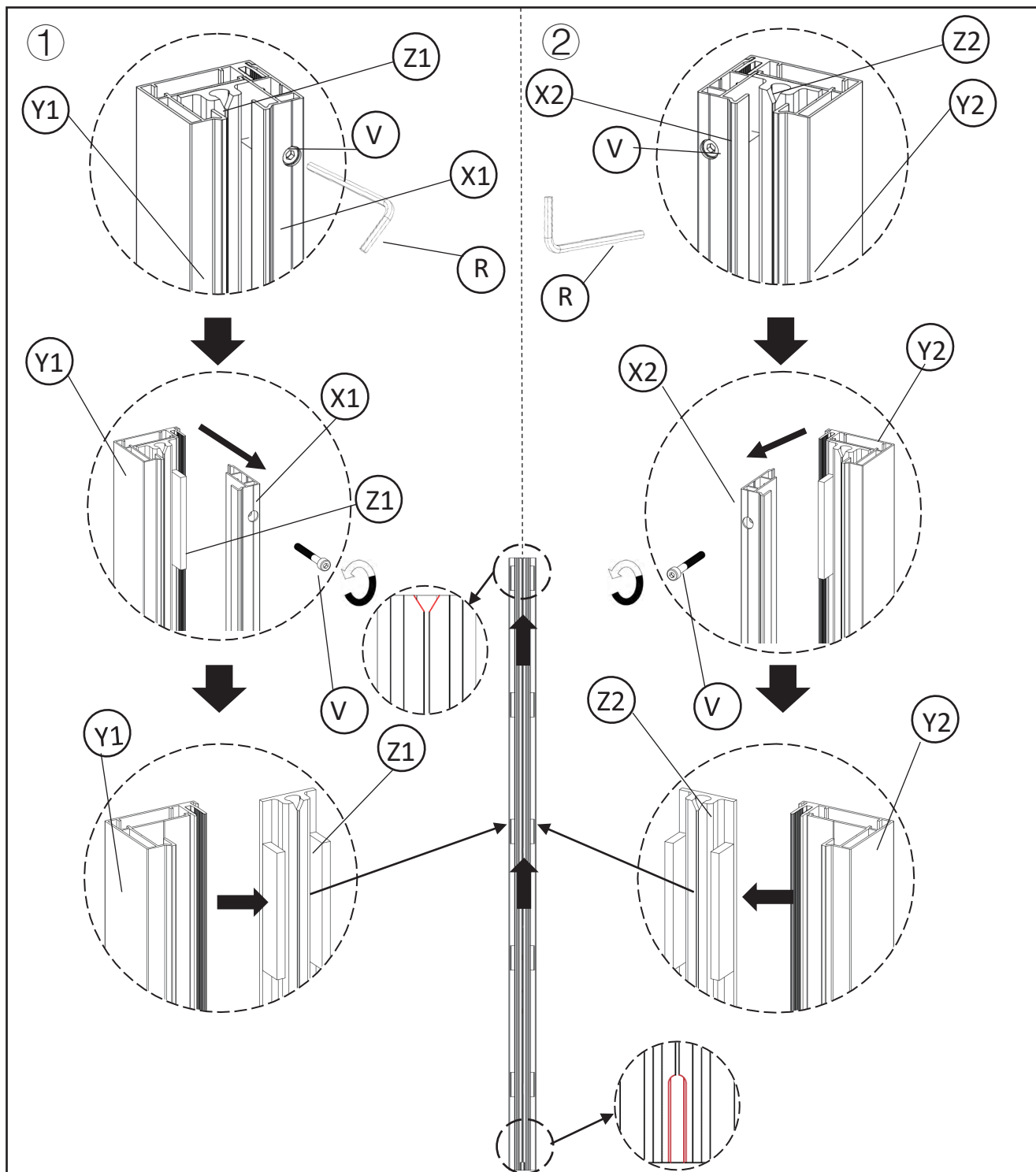

X 30 minutes

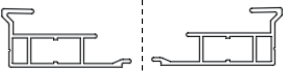

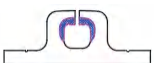
R		\	×1
V		M4*25mm	×8
X1/X2		\	×1/×1
Y1/Y2		\	×1/×1
Z1/Z2		\	×2

③

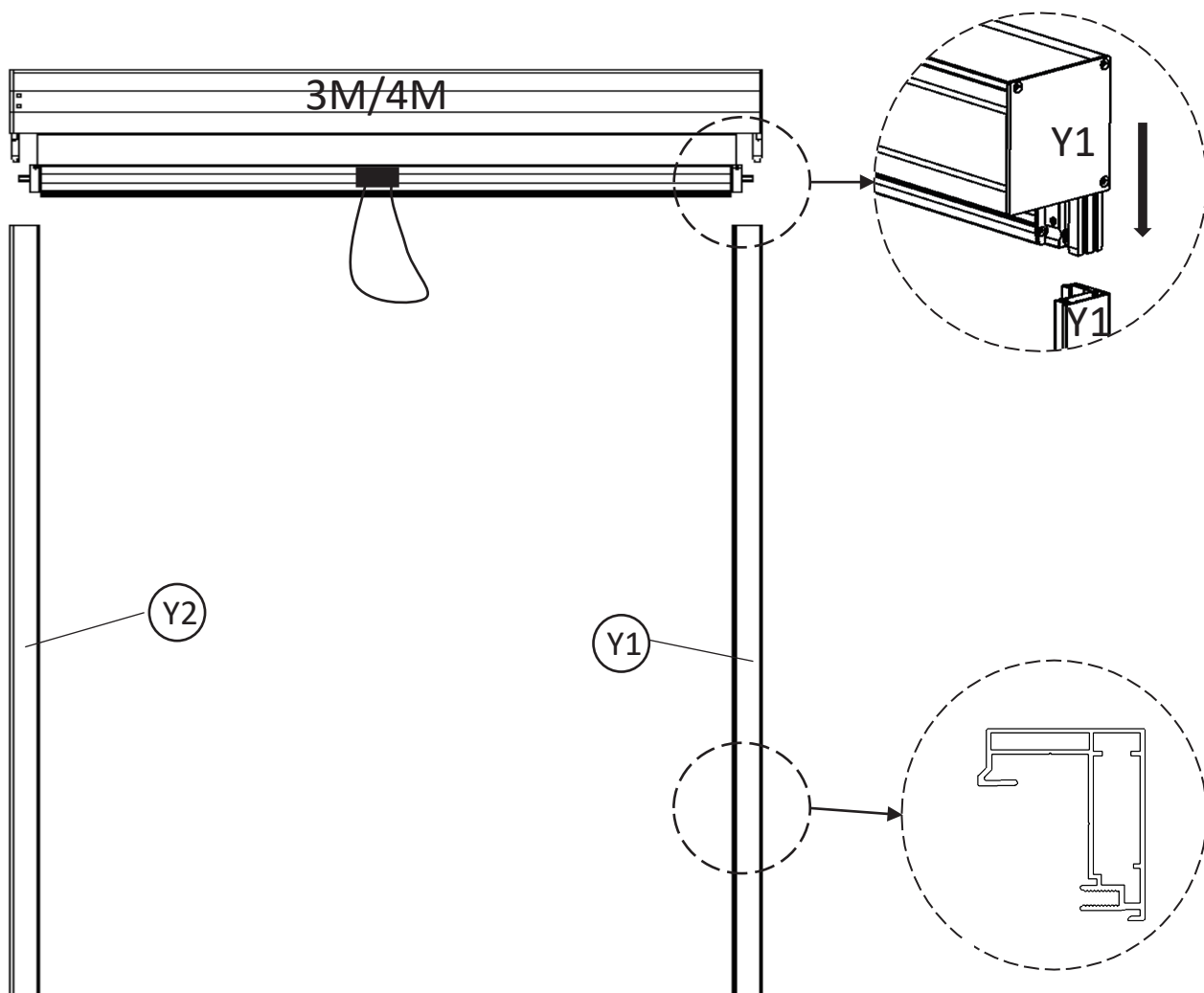

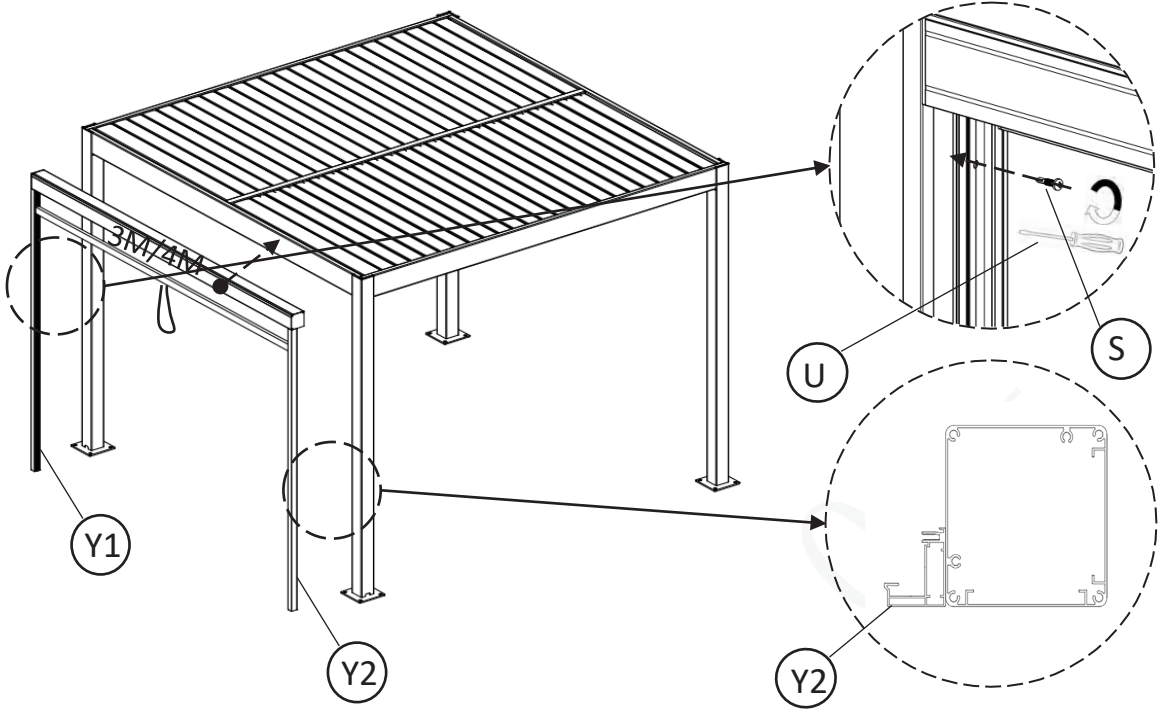

④

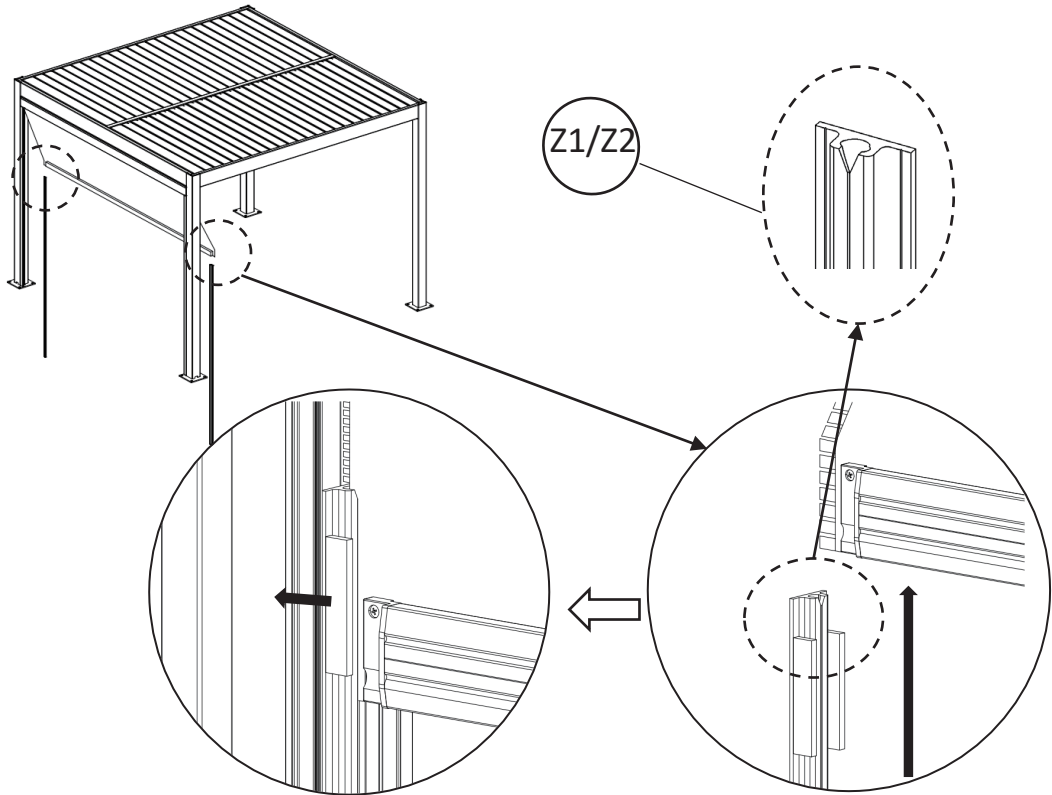

⑤

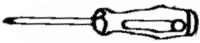





U		\	×1
S		M3.9*16mm	×8

⑥

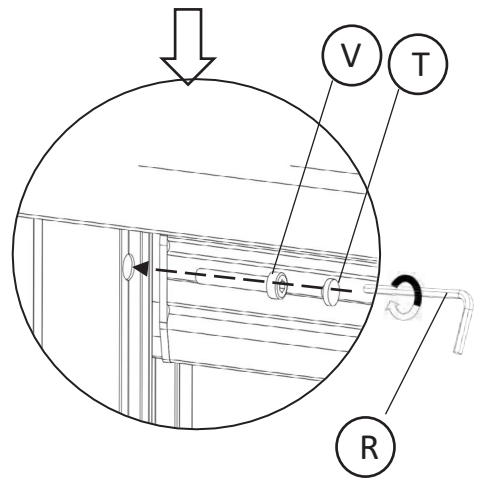
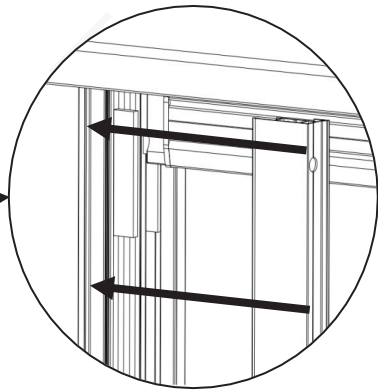
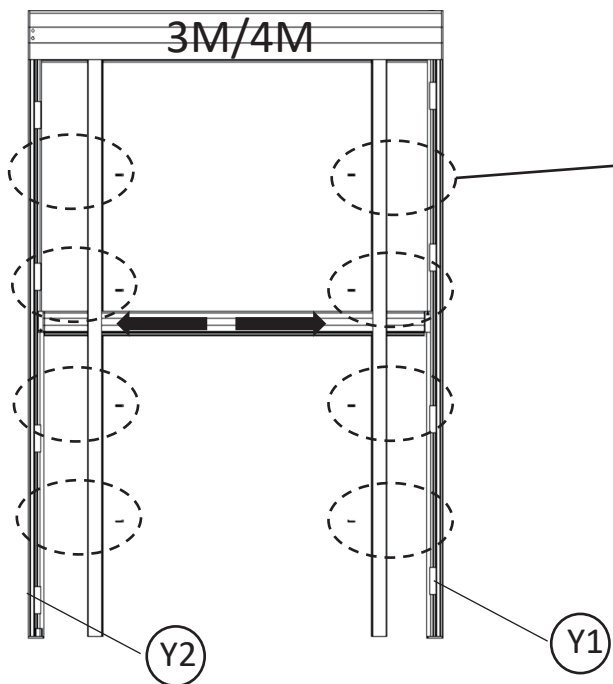
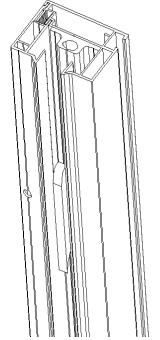
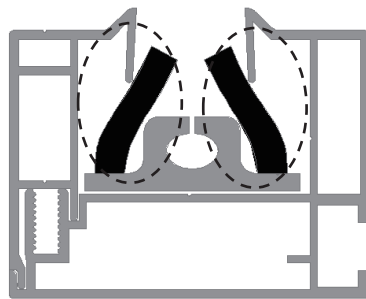
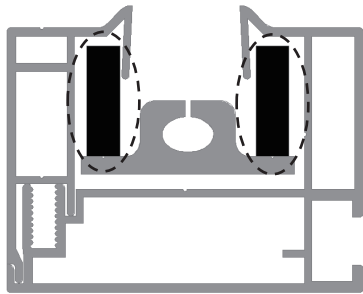
✓

✗



R		\	×1
T		M4	×8
V		M4*25mm	×8

7

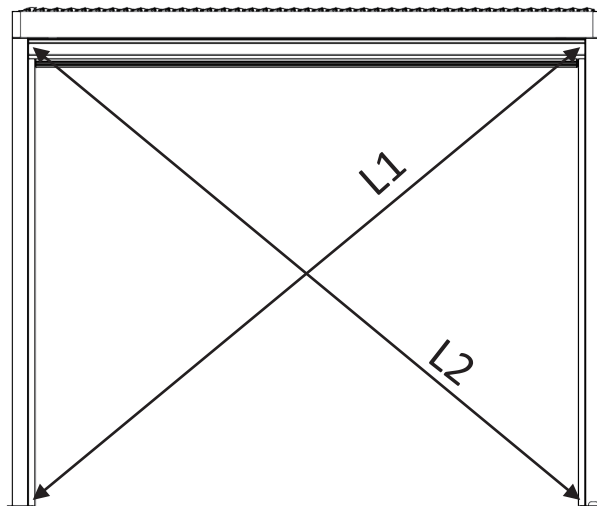
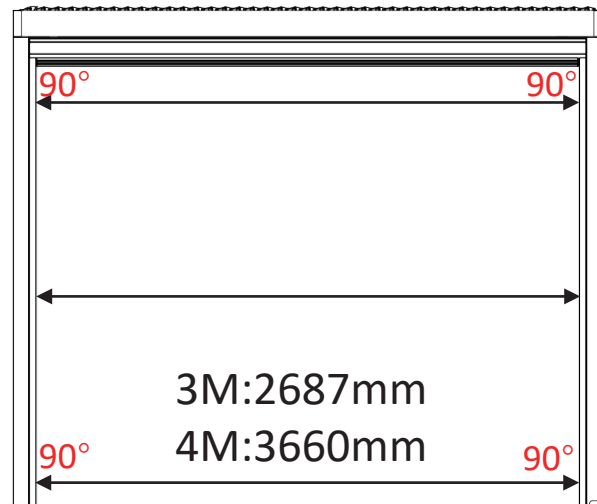

L1=L2 ✓

8

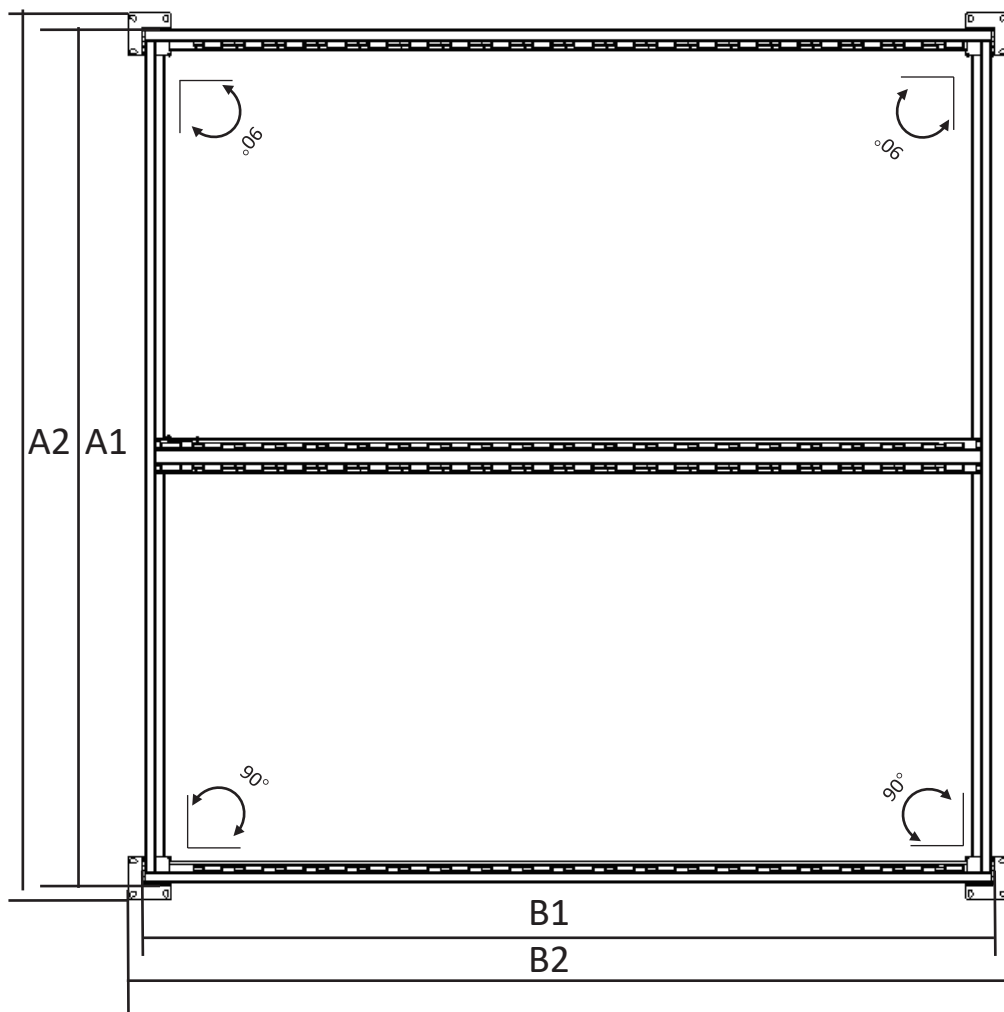

Size of Pergola	A1	A2	B1	B2
3*4M	2887mm	2987mm	3860mm	3960mm

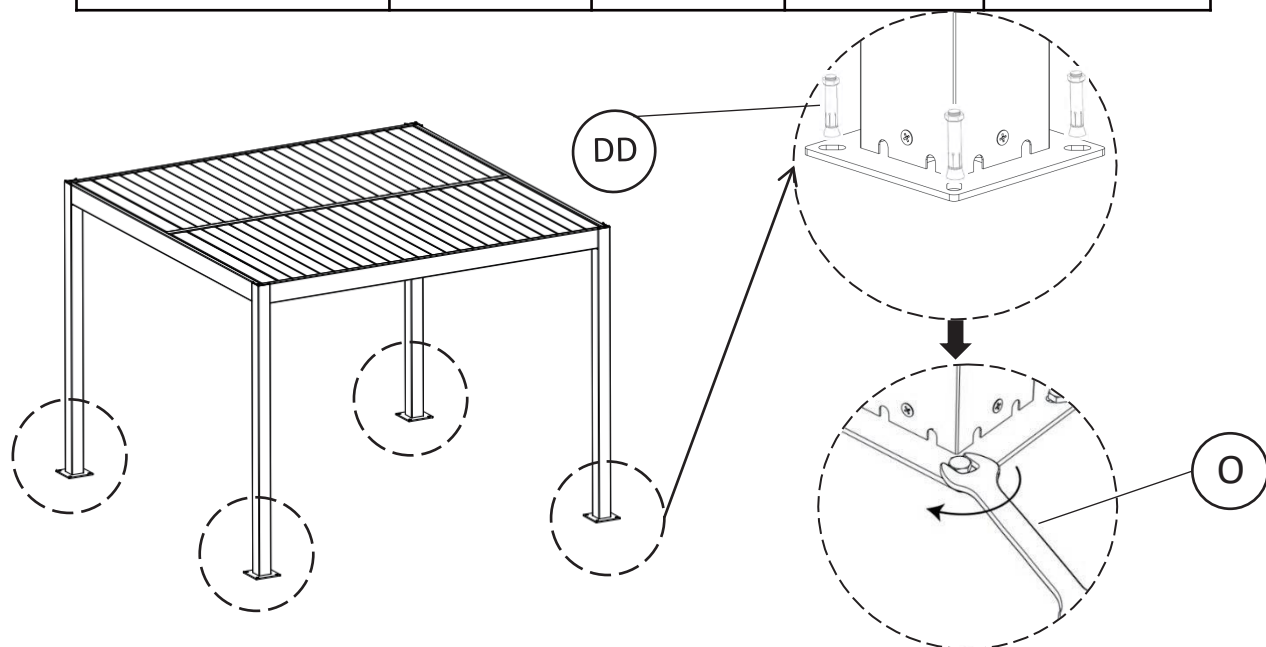

DD



M10\*100mm

×16

9

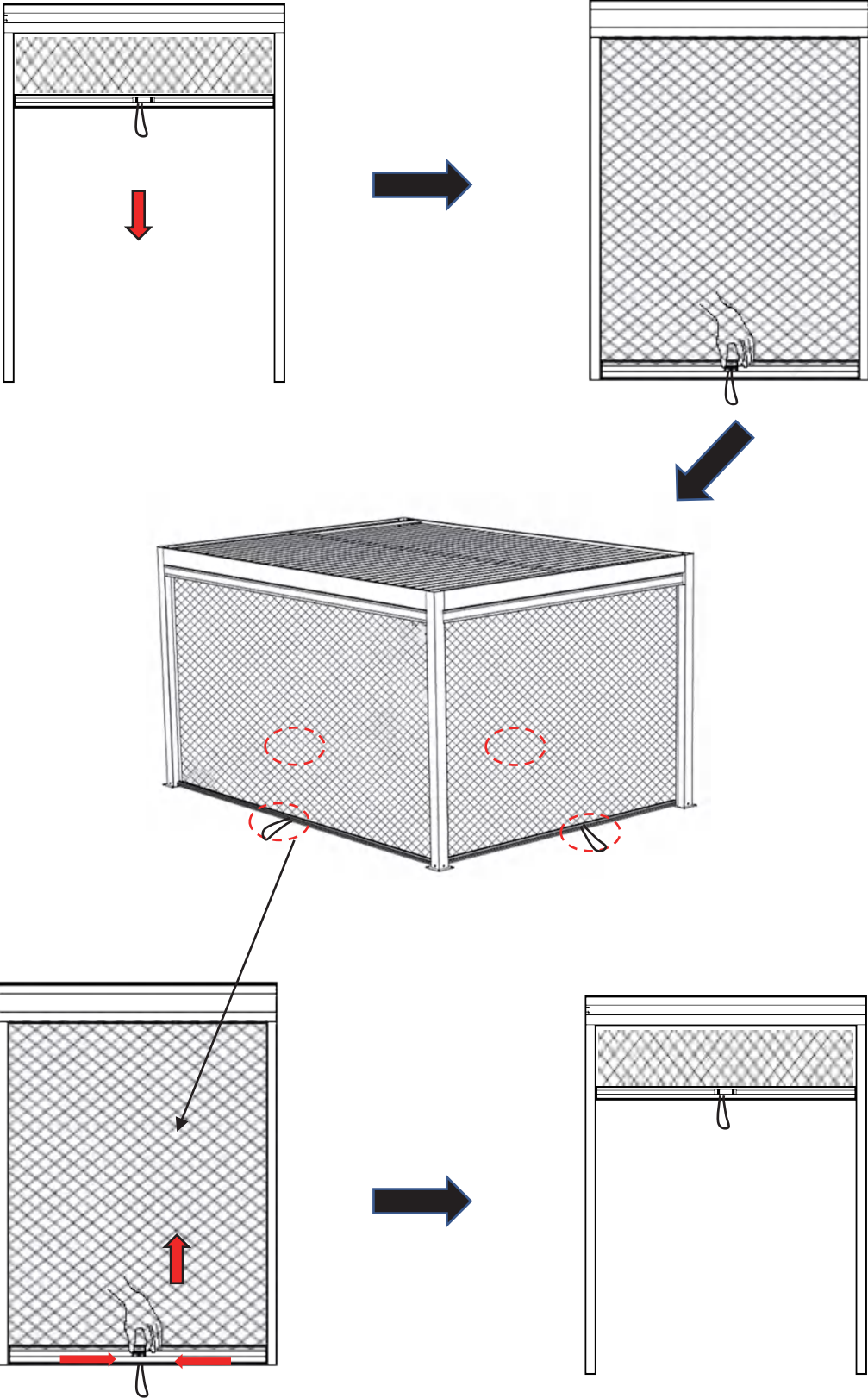

**EN (English):**

The roller blinds must be rolled up during strong winds and should not remain open. They are intended for use as sun protection only.

**DE (Deutsch):**

Die Rollläden müssen bei starkem Wind hochgerollt werden und dürfen nicht offen bleiben. Sie sind nur als Sonnenschutz gedacht.

**HU (Ungarisch):**

Az árnyékolókat erős szél esetén fel kell tekerni, és nem szabad nyitva hagyni. Ezek kizárólag napvédelemre szolgálnak.

**CZ (Tschechisch):**

Rolety musí být při silném větru srolovány a nesmějí zůstat otevřené. Jsou určeny pouze k ochraně před sluncem.

**SK (Slowakisch):**

Rolety musia byť pri silnom vetre zrolované a nesmú zostať otvorené. Sú určené len na ochranu pred slnkom.

**SI (Slowenisch):**

Rolete je treba močno veter zviti navzgor in ne smejo ostati odprte. Namenjene so samo za zaščito pred soncem.

**PL (Polnisch):**

Rolety należy zwinąć podczas silnego wiatru i nie powinny pozostawać otwarte. Służą wyłącznie do ochrony przed słońcem.

**HR (Kroatisch):**

Roletne se moraju podići tijekom jakog vjetra i ne smiju ostati otvorene. Namijenjene su isključivo za zaštitu od sunca.

**RO (Rumänisch):**

Jaluzelele trebuie să fie rulate în timpul vântului puternic și nu trebuie să rămână deschise. Sunt destinate exclusiv protecției solare.

**SE (Schwedisch):**

Rullgardinerna måste rullas upp vid kraftig vind och får inte lämnas öppna. De är avsedda enbart för solskydd.

**RS (Serbisch):**

Roletne treba da se podignu tokom jakog vetra i ne smeju ostati otvorene. Namenjene su samo za zaštitu od sunca.

**BG (Bulgarisch):**

Щорите трябва да се навият по време на силен вятър и не трябва да остават отворени. Те са предназначени само за слънцезащита.

**FR (Französisch):**

Les stores doivent être enroulés par vent fort et ne doivent pas rester ouverts. Ils sont destinés uniquement à la protection solaire.





06390087/01

XXXLutz KG  
Roemerstrasse 39  
AT-4600 Wels Austria  
Info@xxxlutz.at

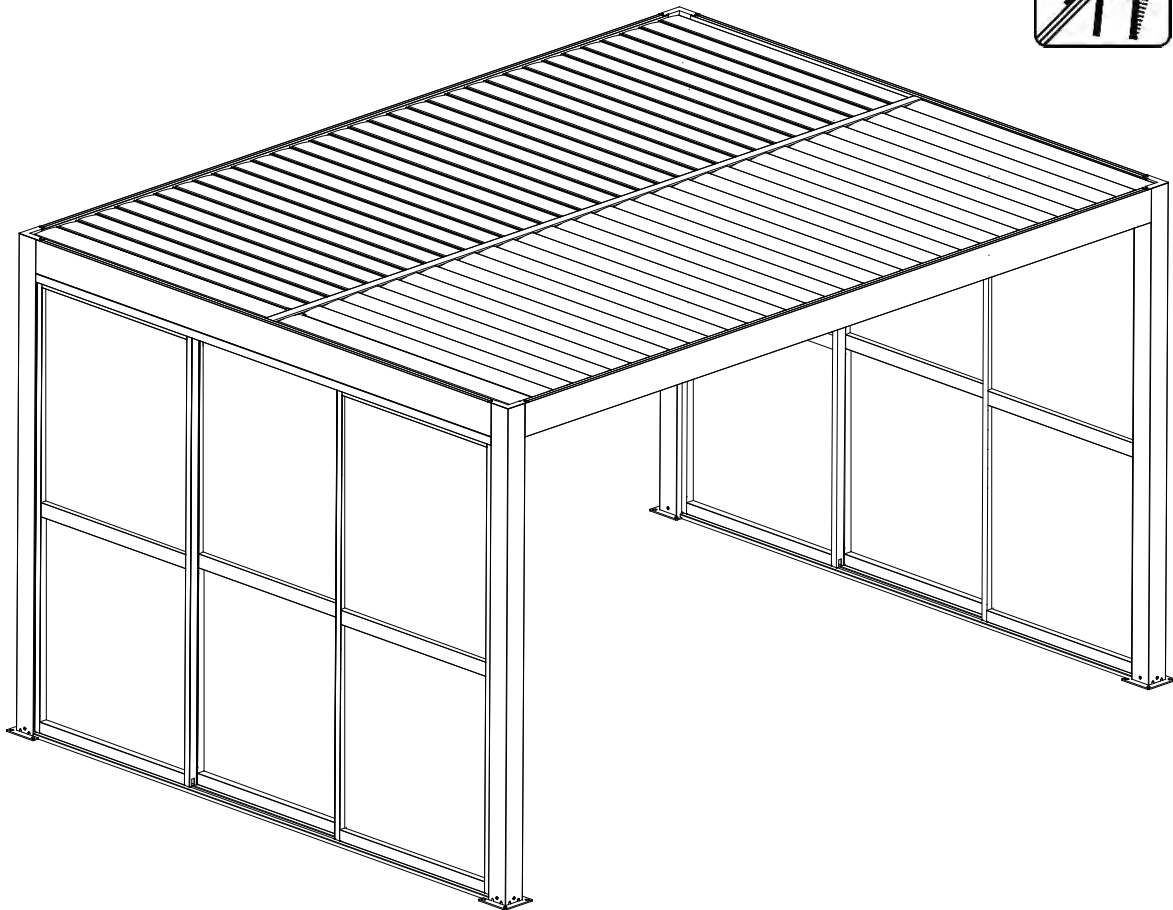
Vorsicht Glas!

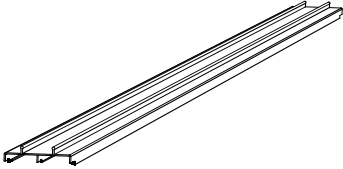
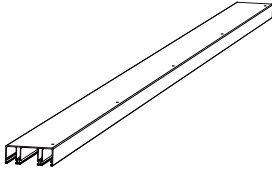
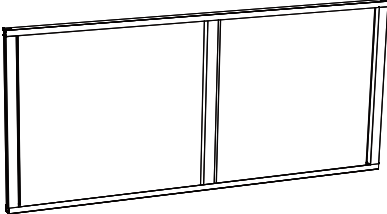
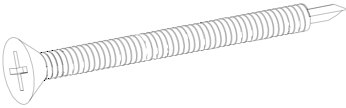

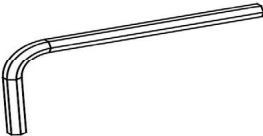
	pic	qty
A3/A4		1
B3/B4		1
C3/C4		1
D		1~3
F	 M3.9*38	10
G	  M5*60+M10*50	10
H	 5mm	1

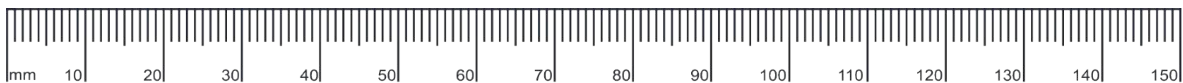

X 30 minutes

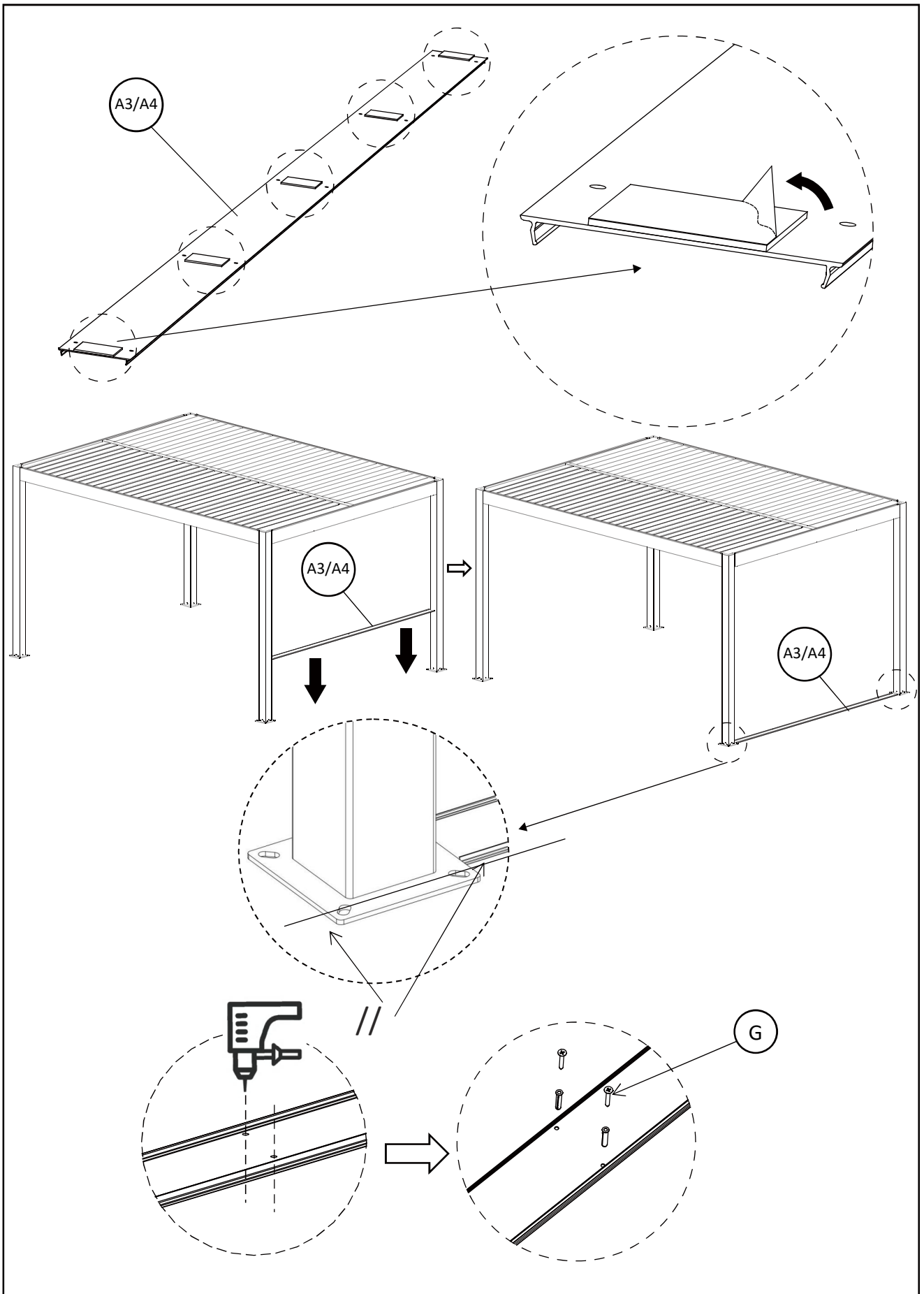

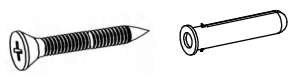
G		M5*60+M10*50	X10
---	---	--------------	-----

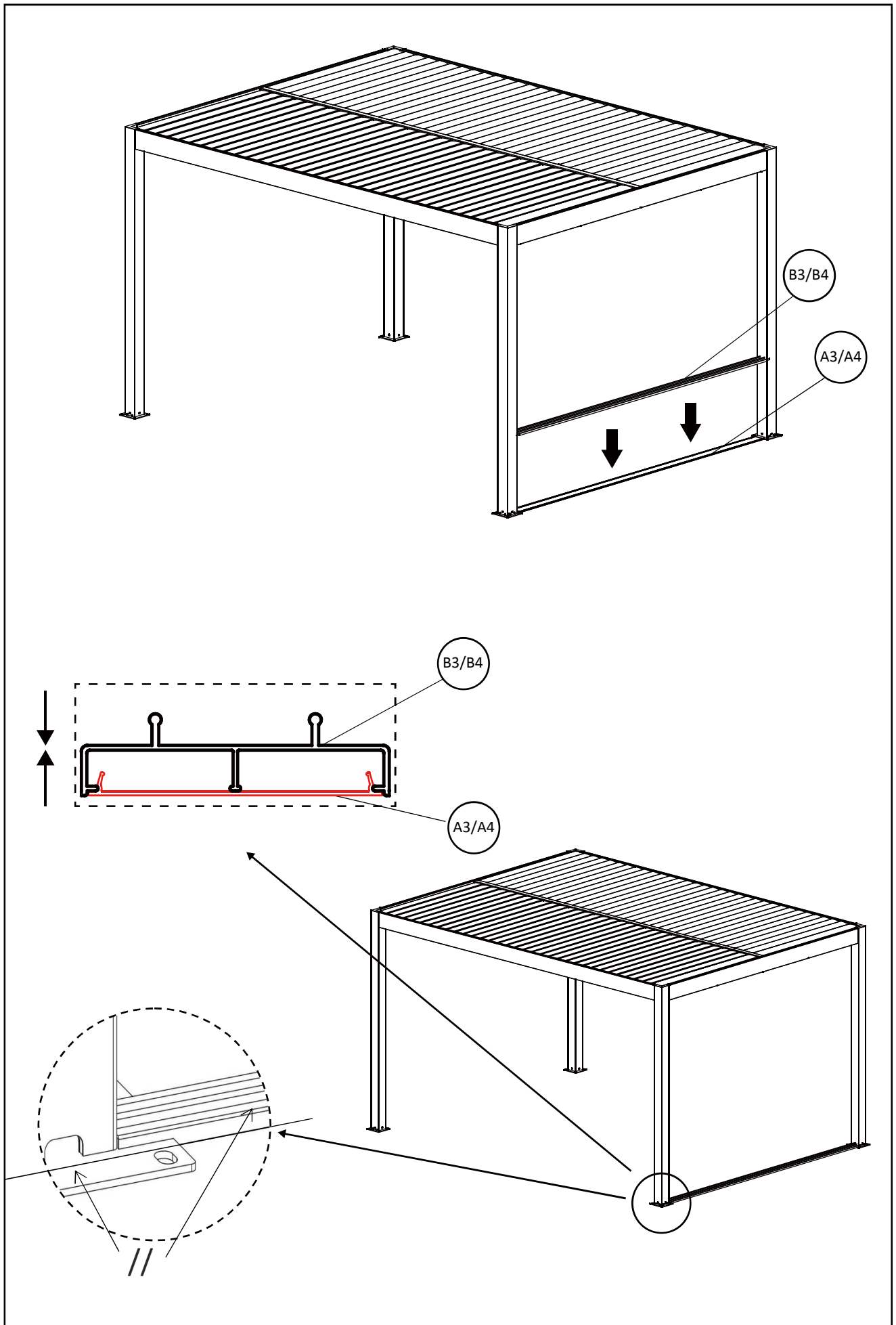

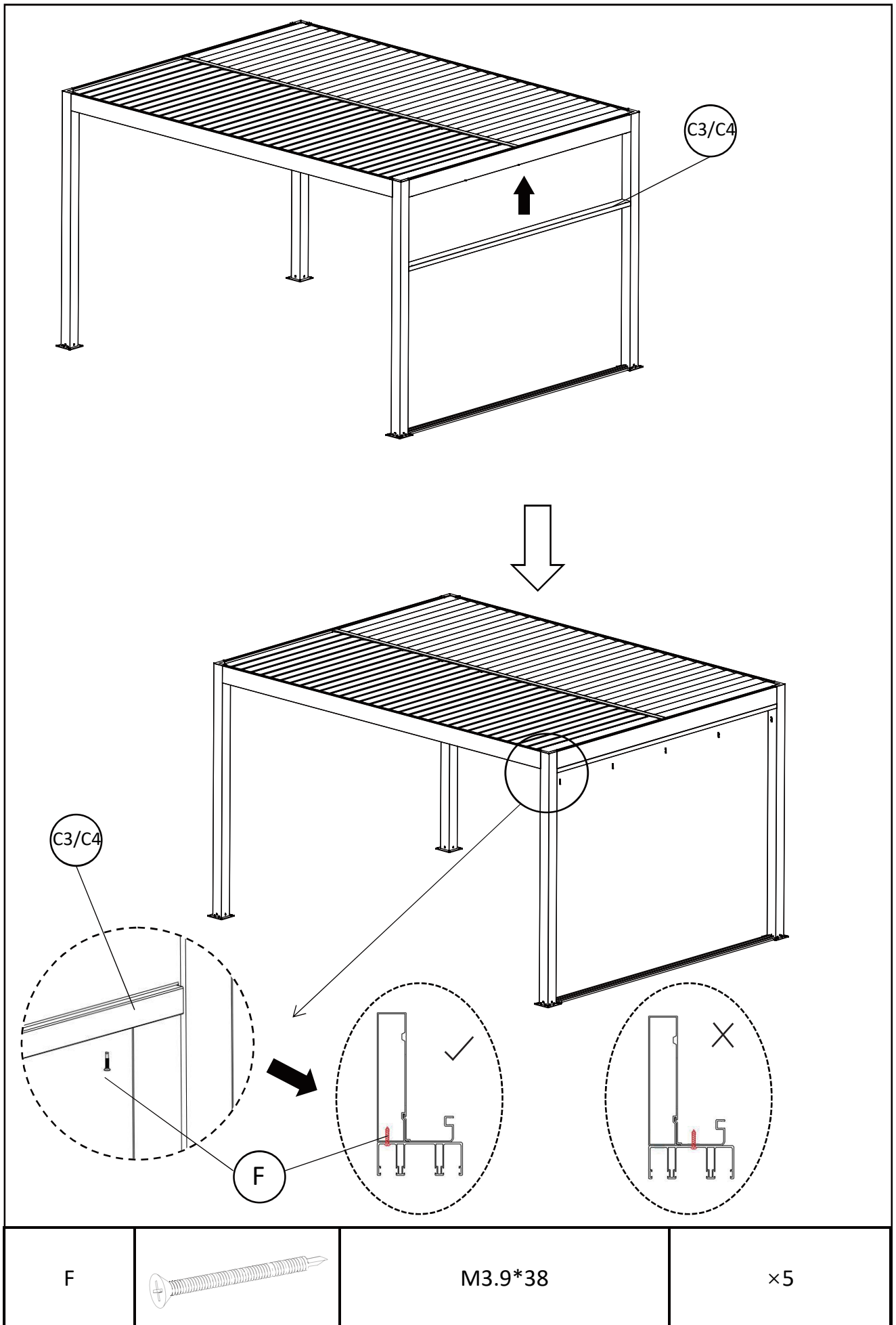

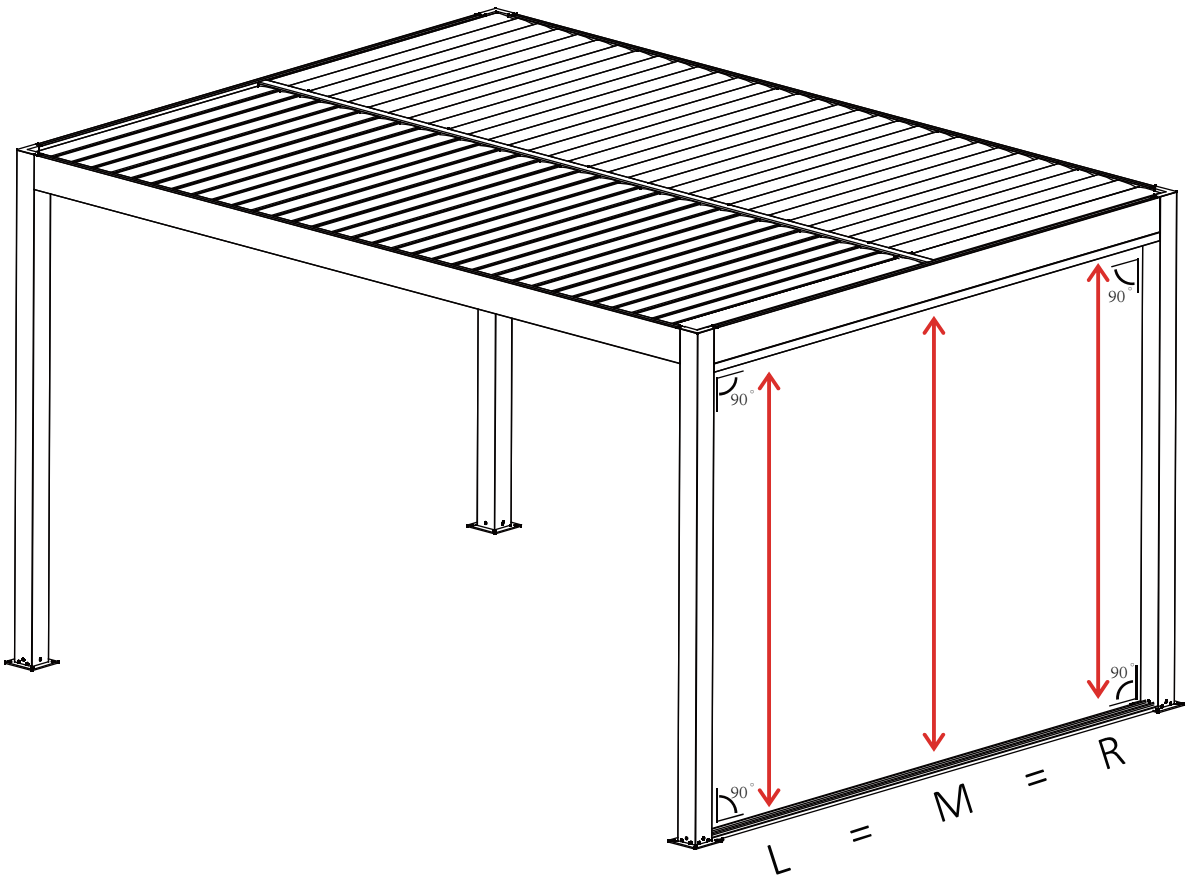

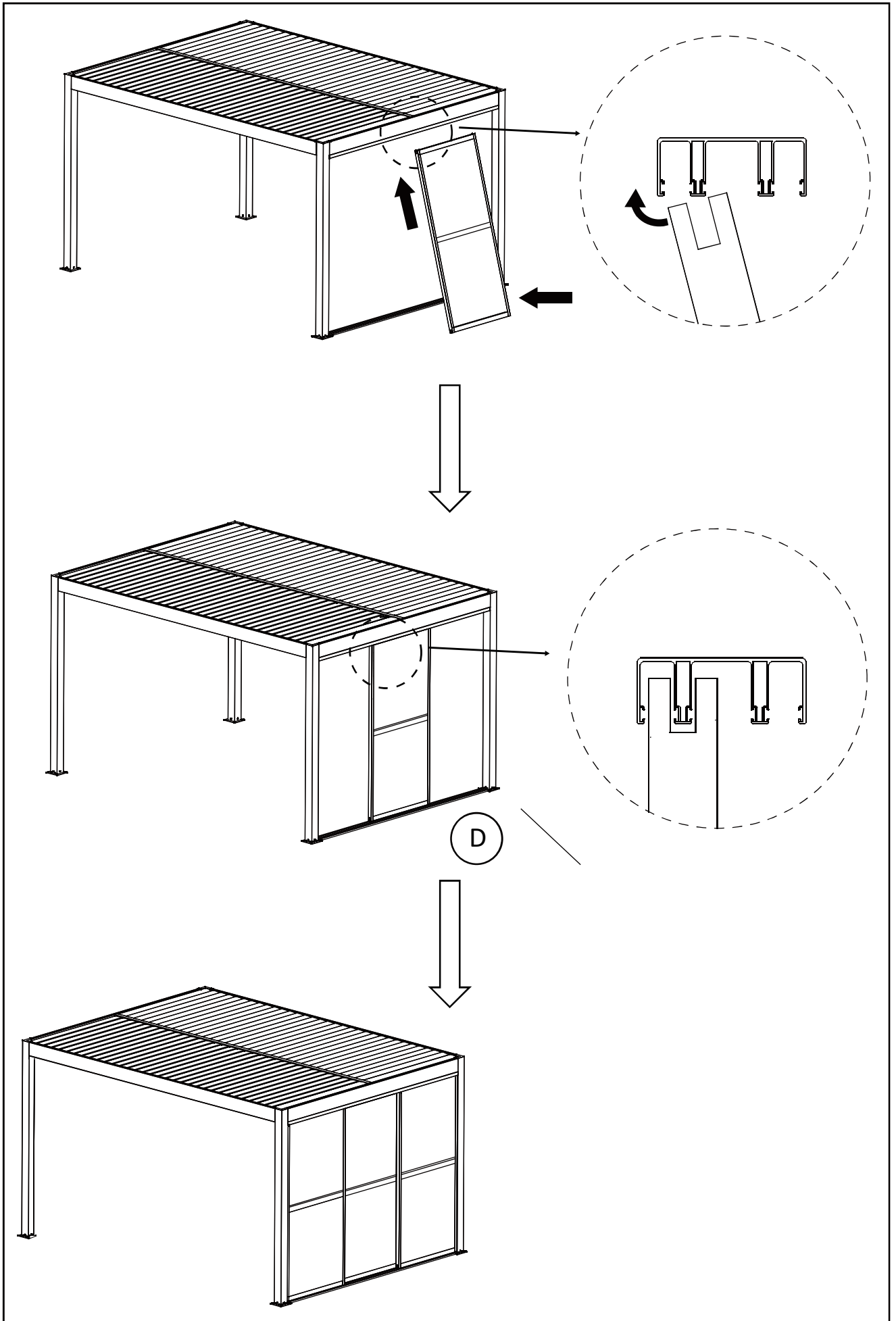

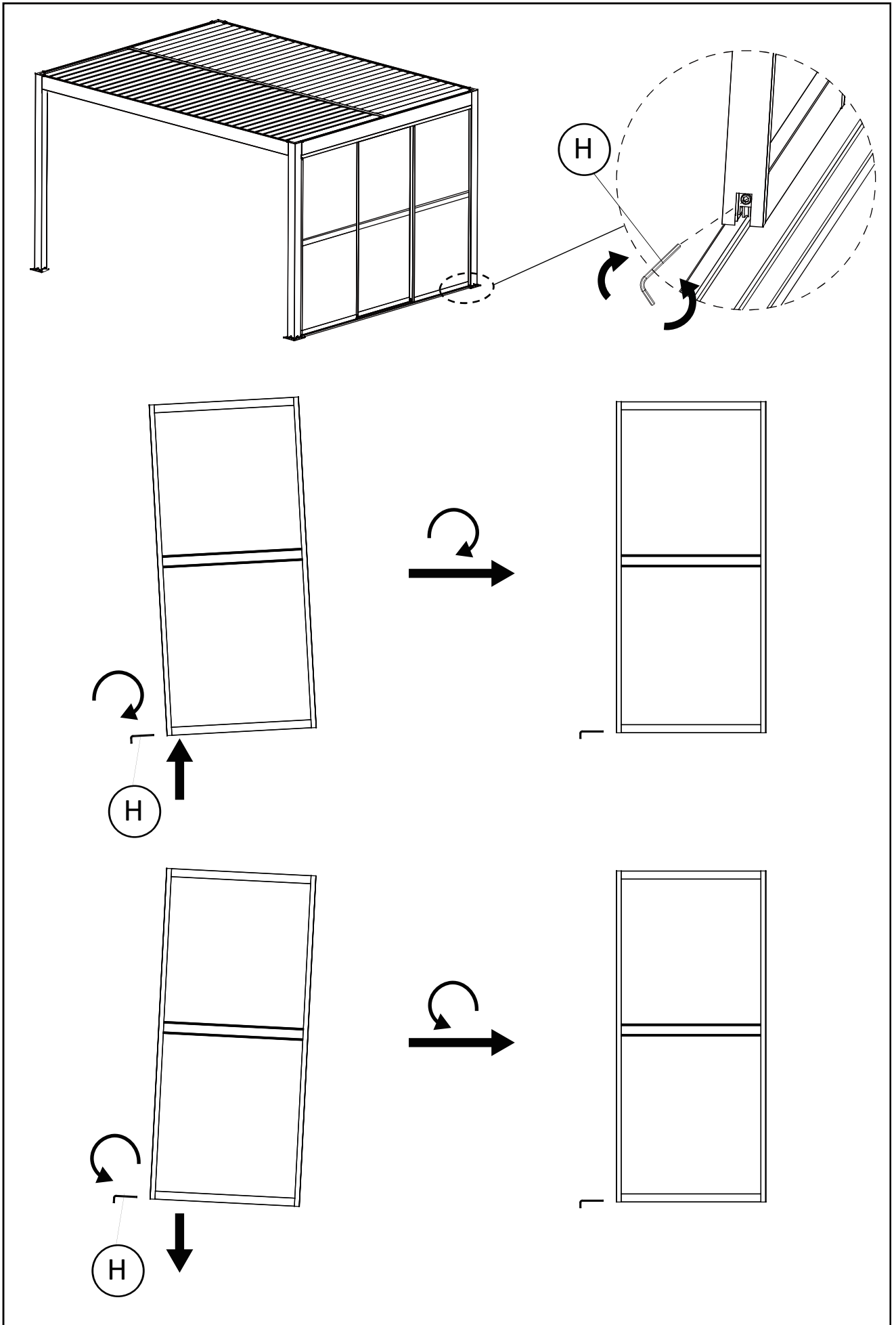

3M:

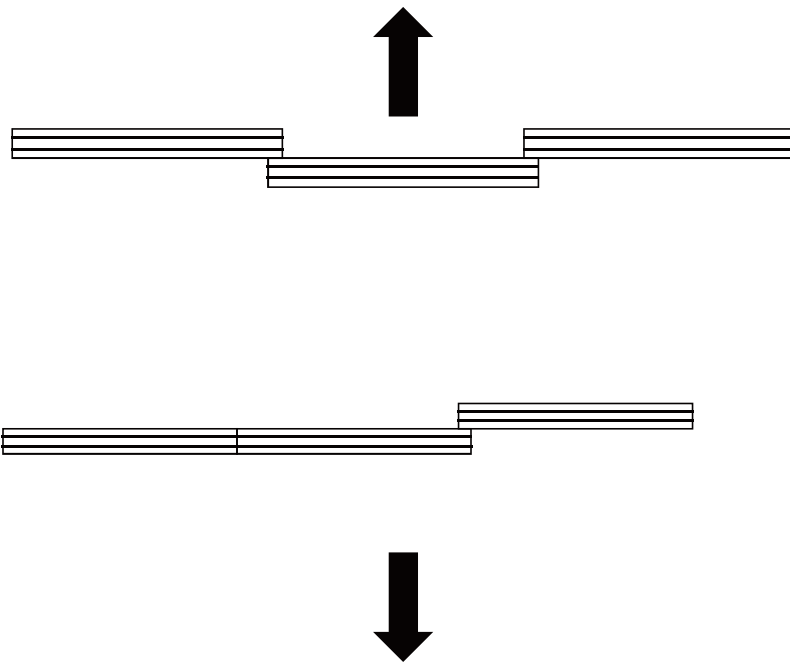









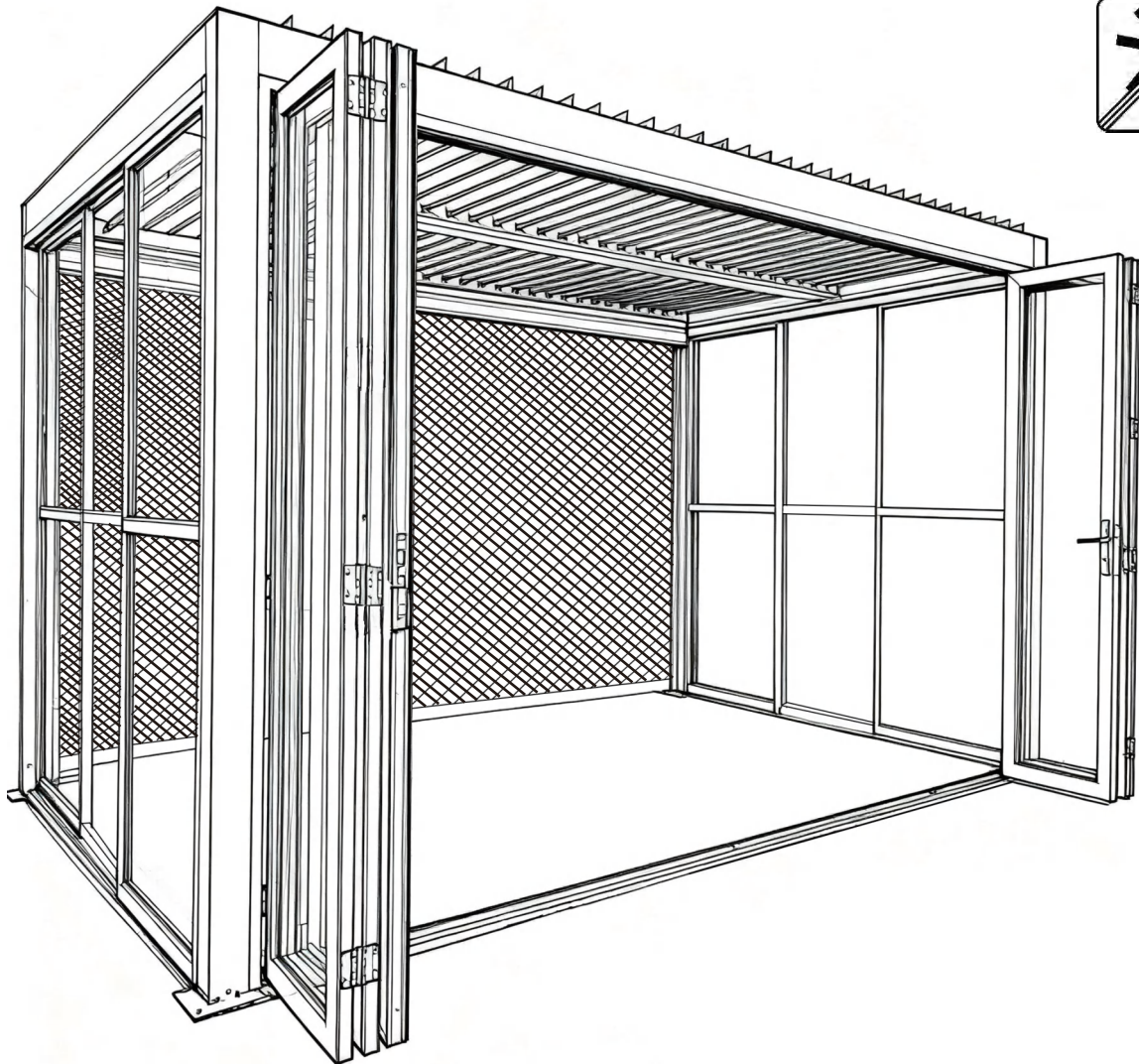

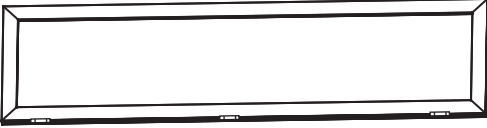
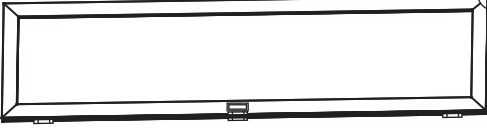
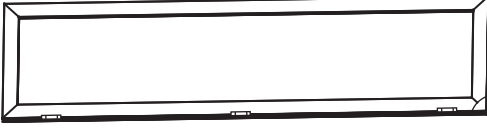
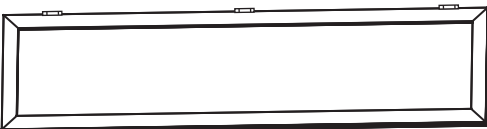
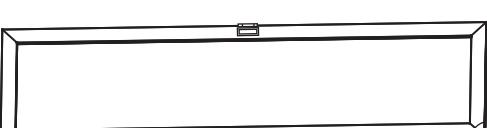
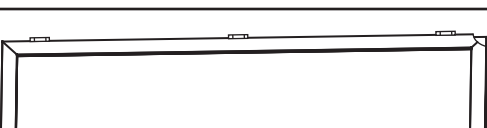

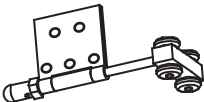

06390087/01

XXXLutz KG  
Roemerstrasse 39  
AT-4600 Wels Austria  
Info@xxxlutz.at

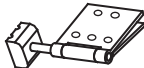
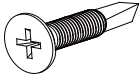
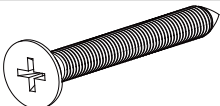
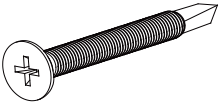
Vorsicht Glas!

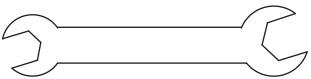
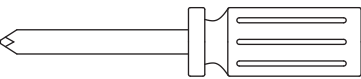
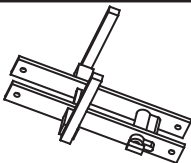
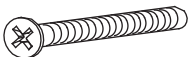

	pic	qty
L1		X1
L2		X1
L3		X1
R1		X1
R2		X1
R3		X1
A4		X1
B4		X1
L0		X1
R0		X1
A		X2
B		X2

C			X2
D		ST3.5x16	X110+5
E		ST3.9x40	X4+2
F		ST3.9x38	X11+2
G		ST4.8x60	X5+5
H		M10x50	X5+5
I		L5	X1
J		L2	X1
K		10-13mm	X1
L			X1
M			X1
N		M5x50	X2
O		M5x40	X1
P			X2

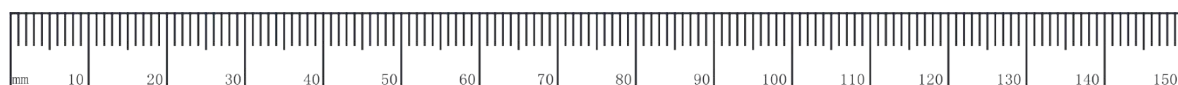

X 3hours

1

B4

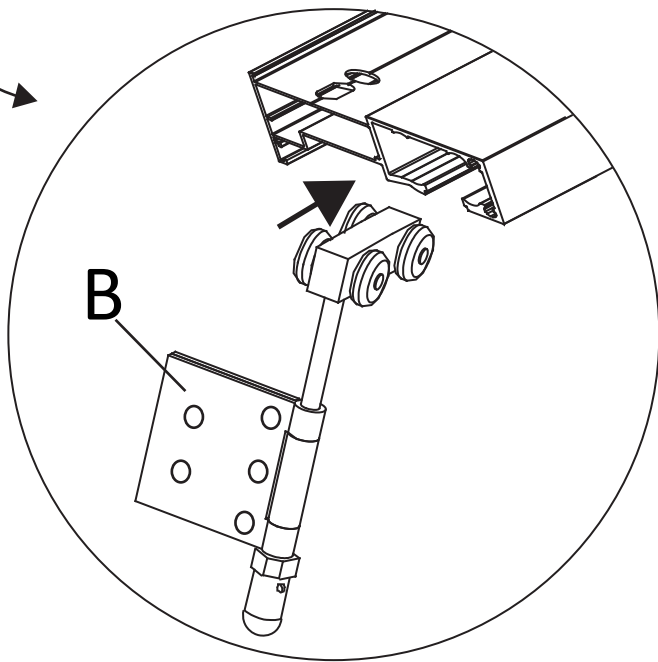
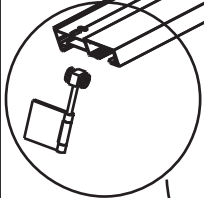

X2

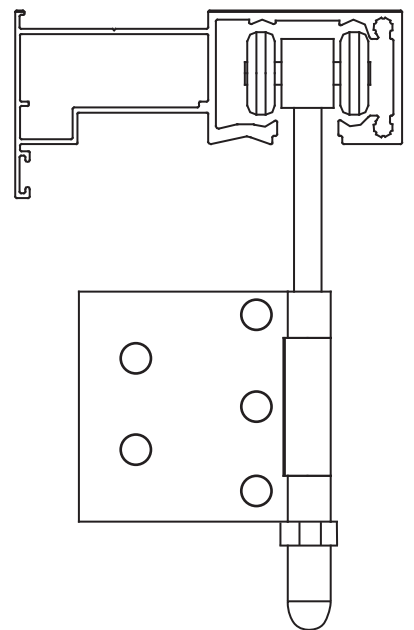

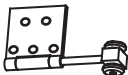
B		X2
---	---	----

2

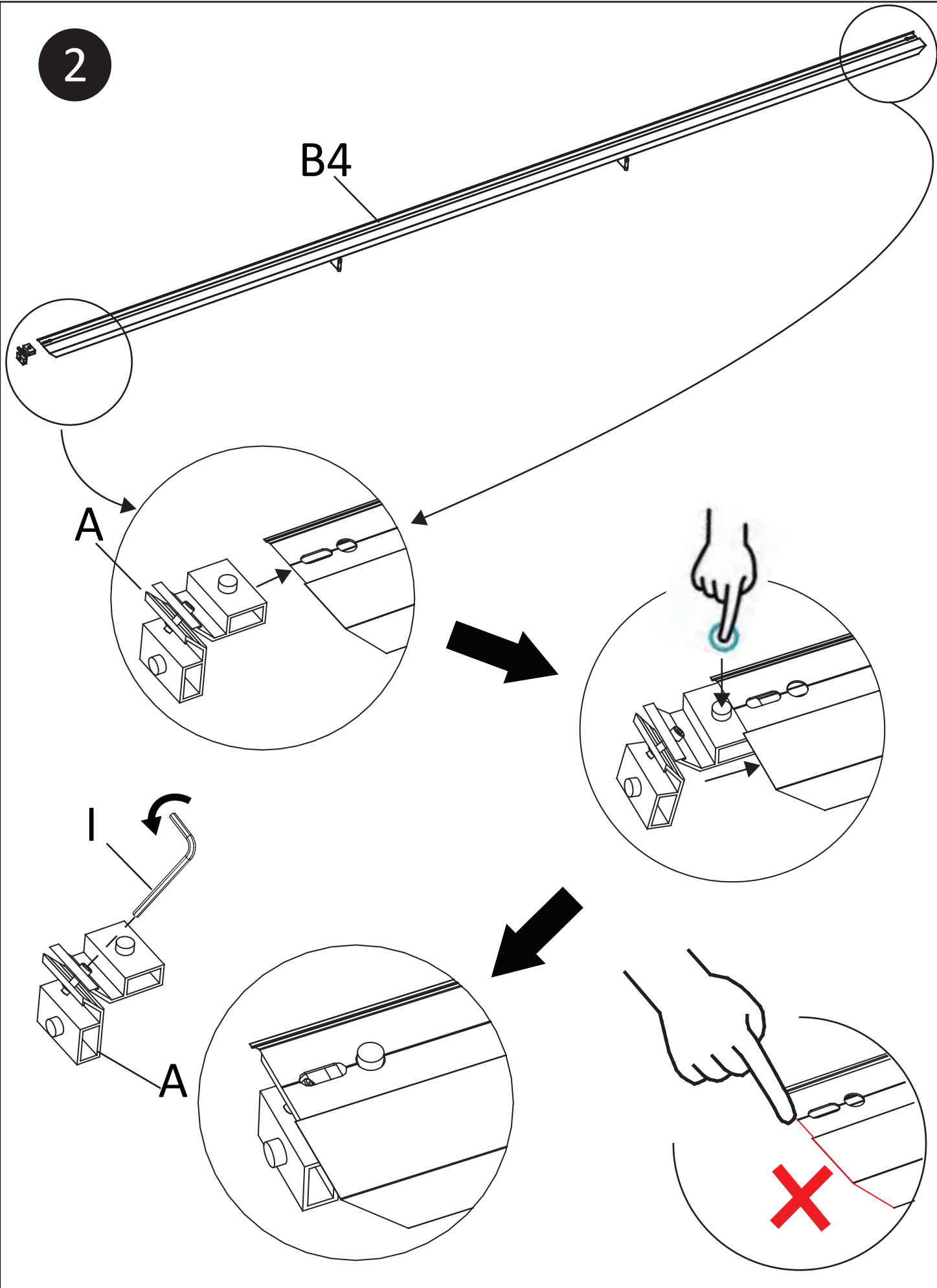

B4

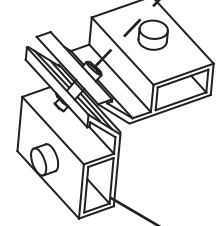
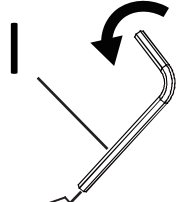
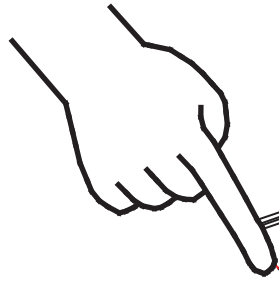

A

A



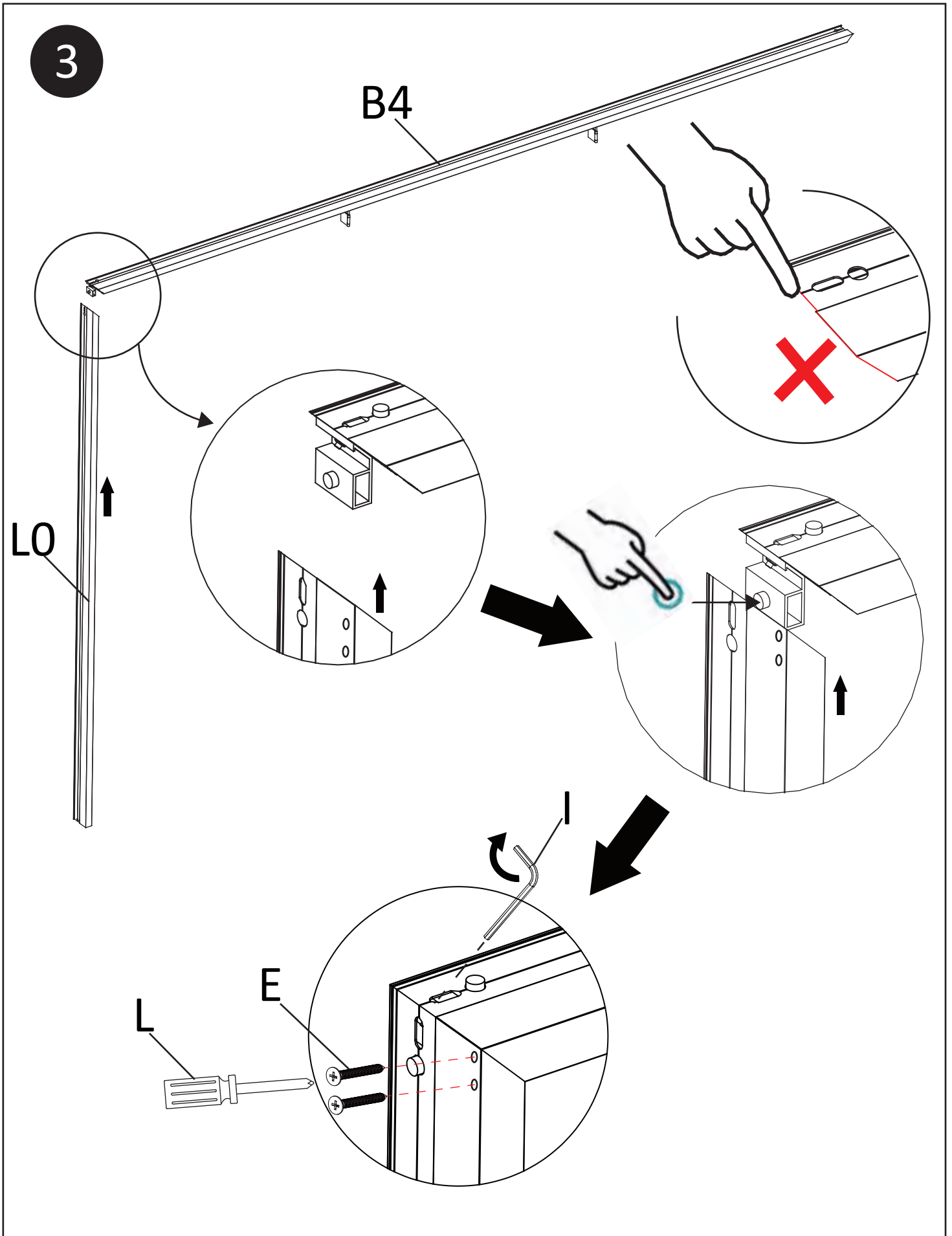

A		X2	I		X1
---	---	----	---	---	----

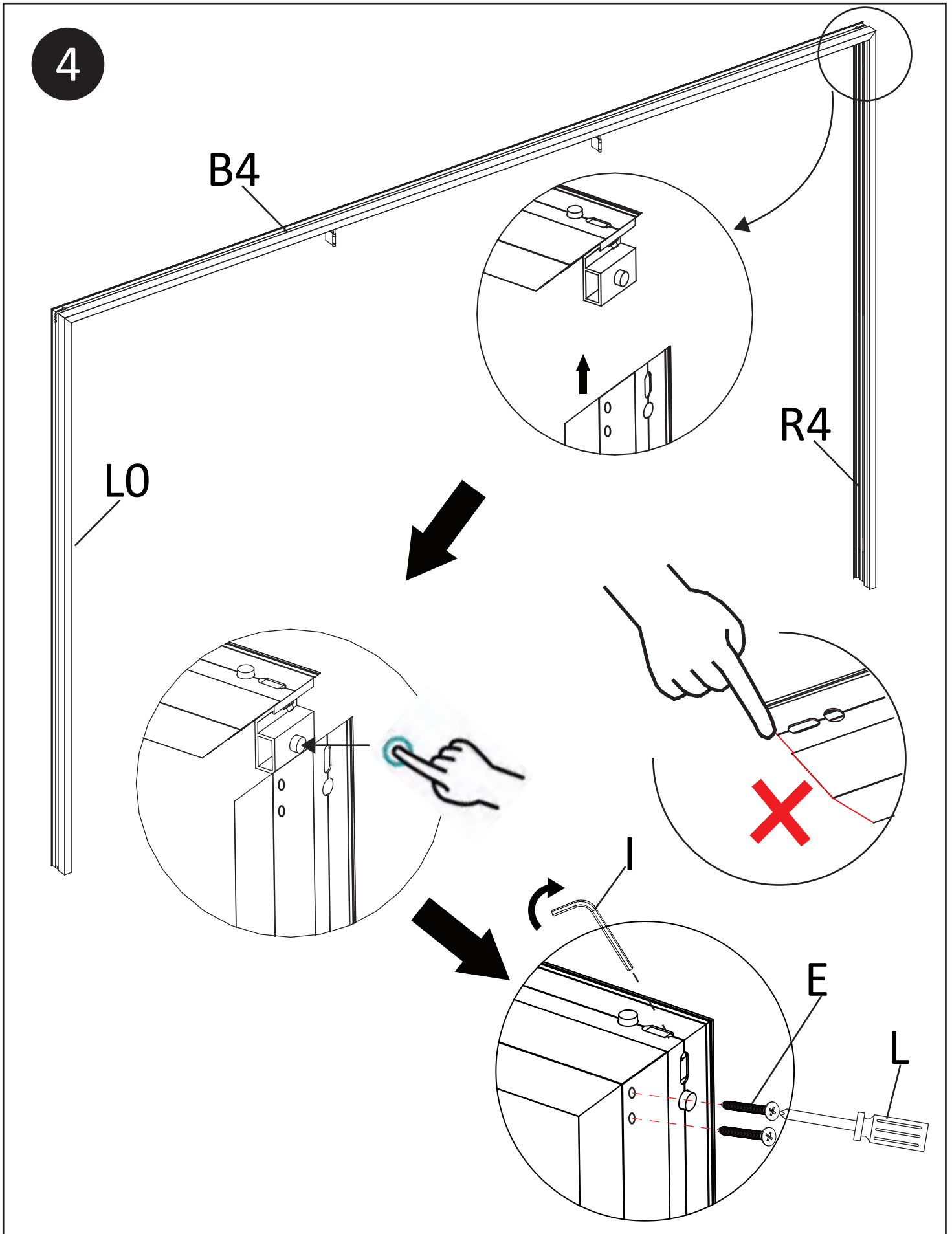

I		L5	X1
L			X1

E		ST3.9x40	X2
---	--	----------	----

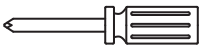

I		L5	X1
L			X1

E		ST3.9x40	X2
---	---	----------	----

5

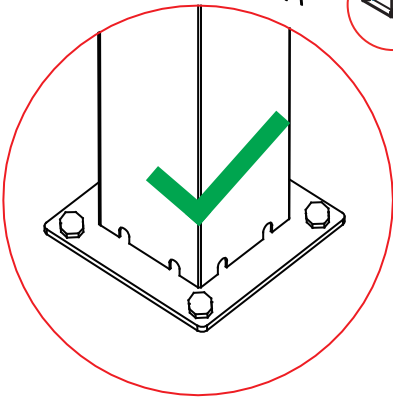
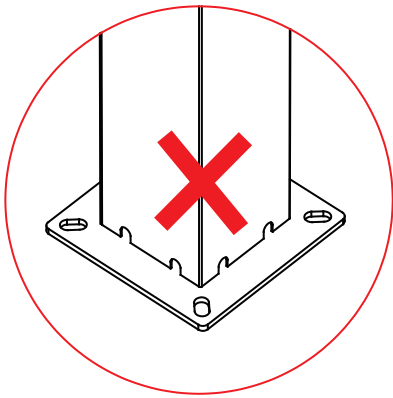
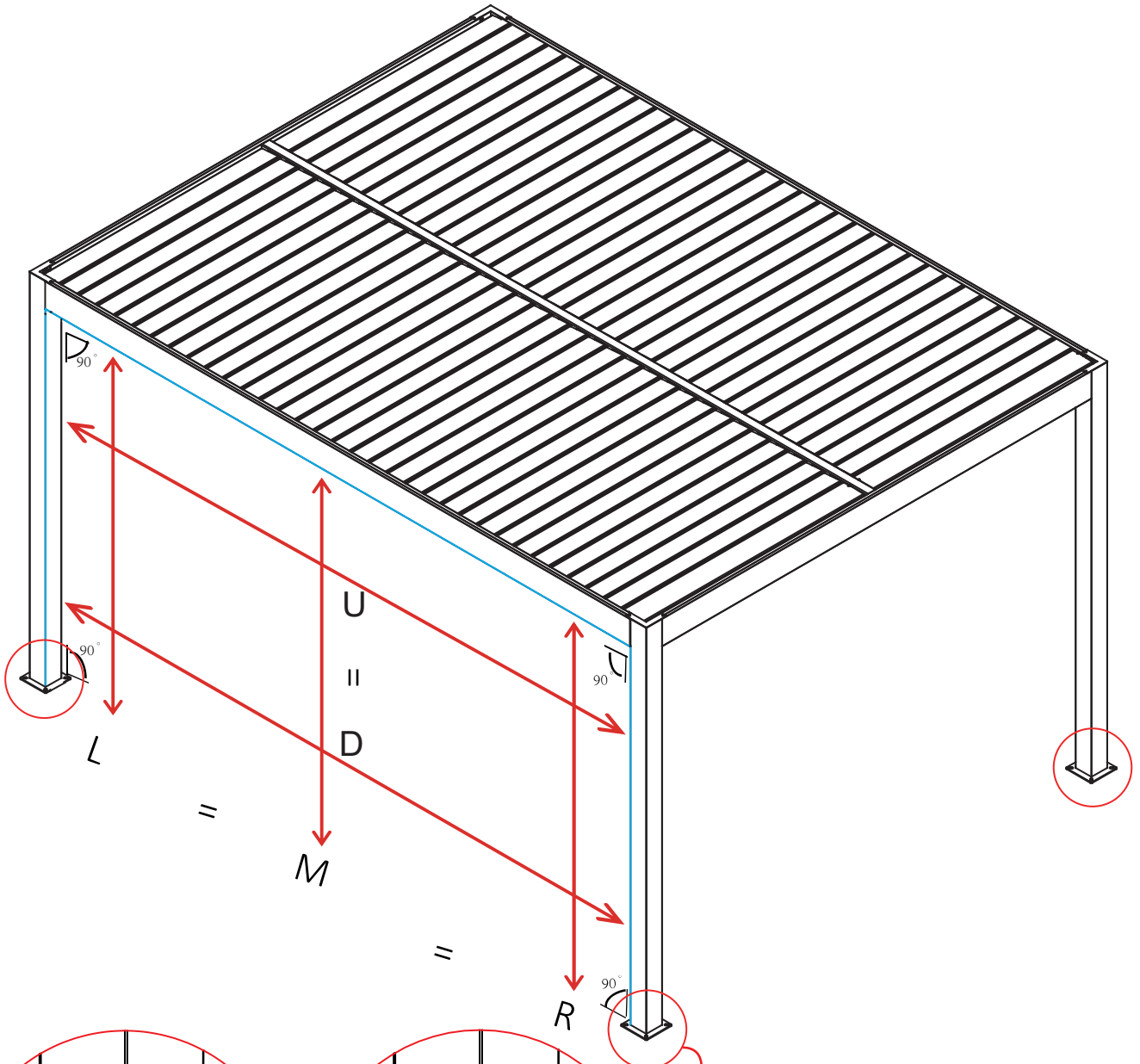

6

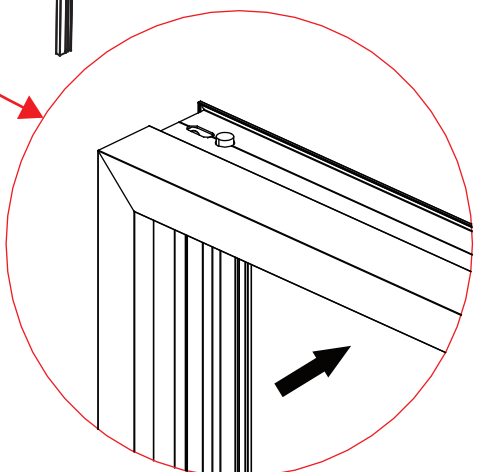
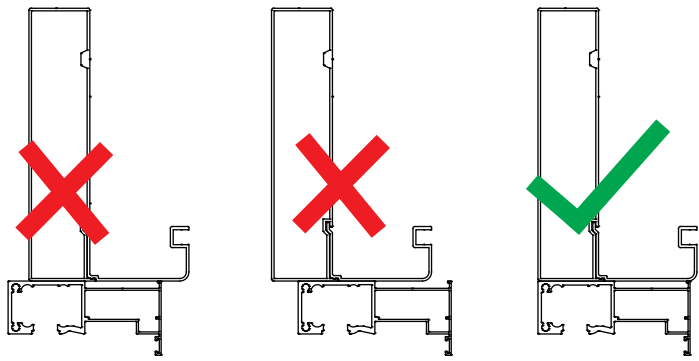
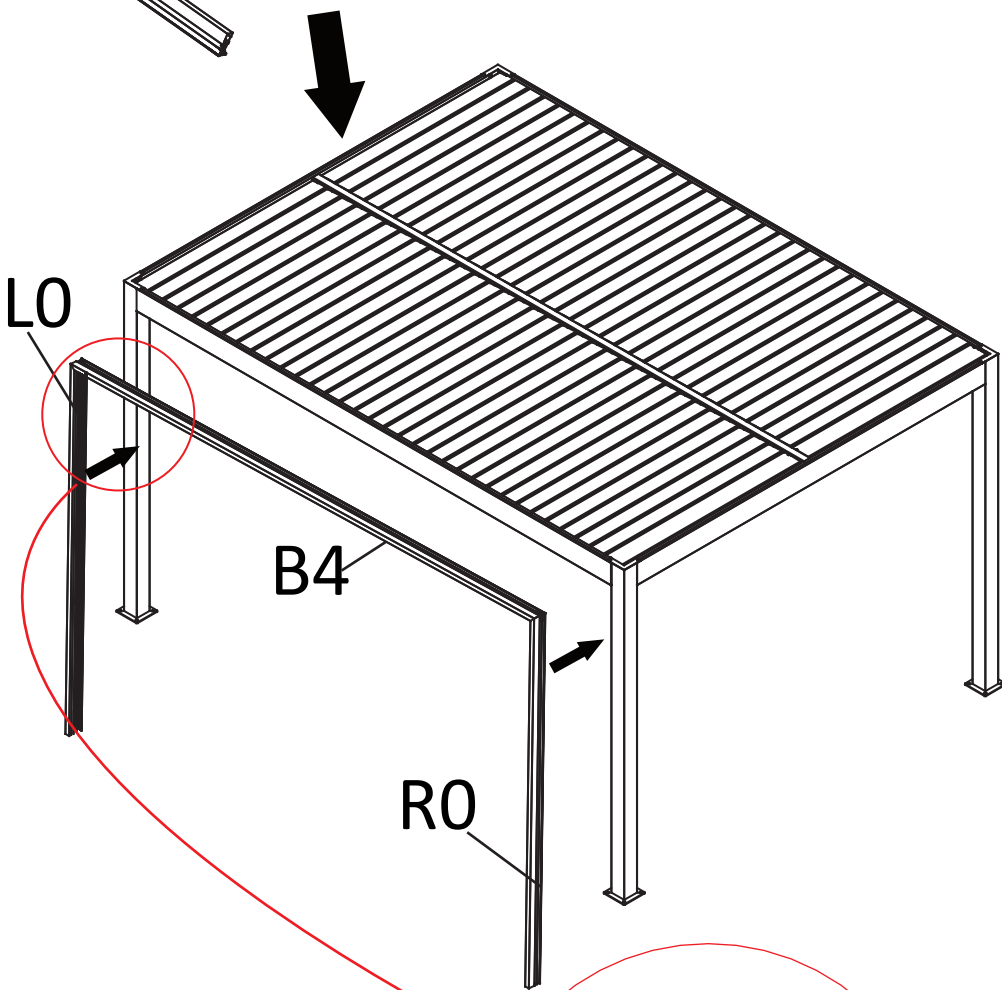
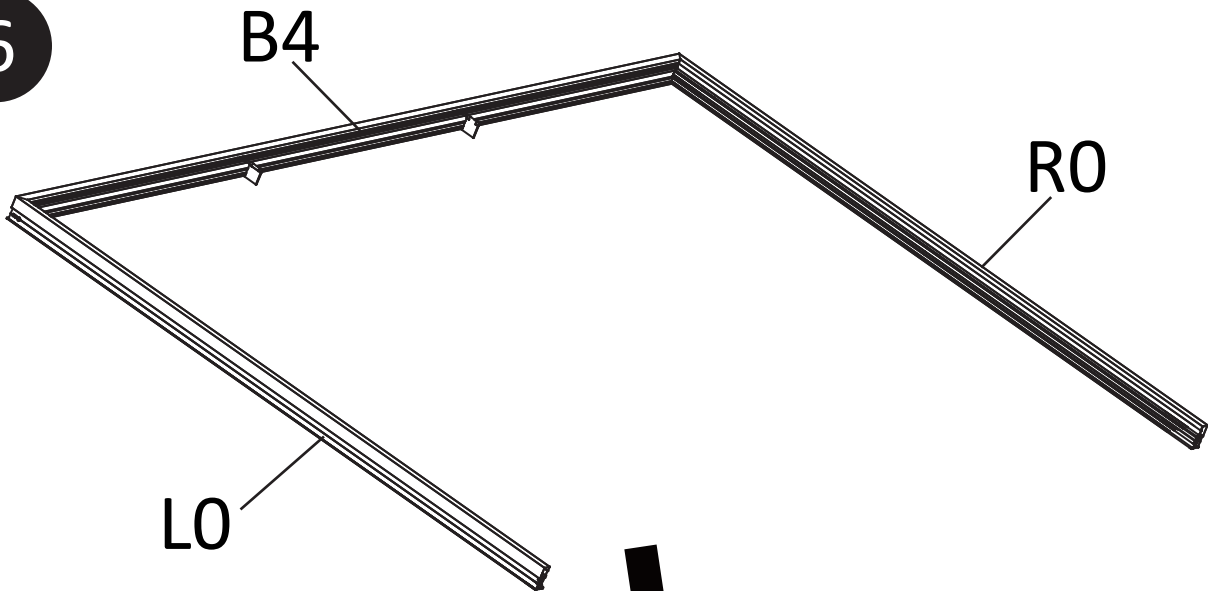

7

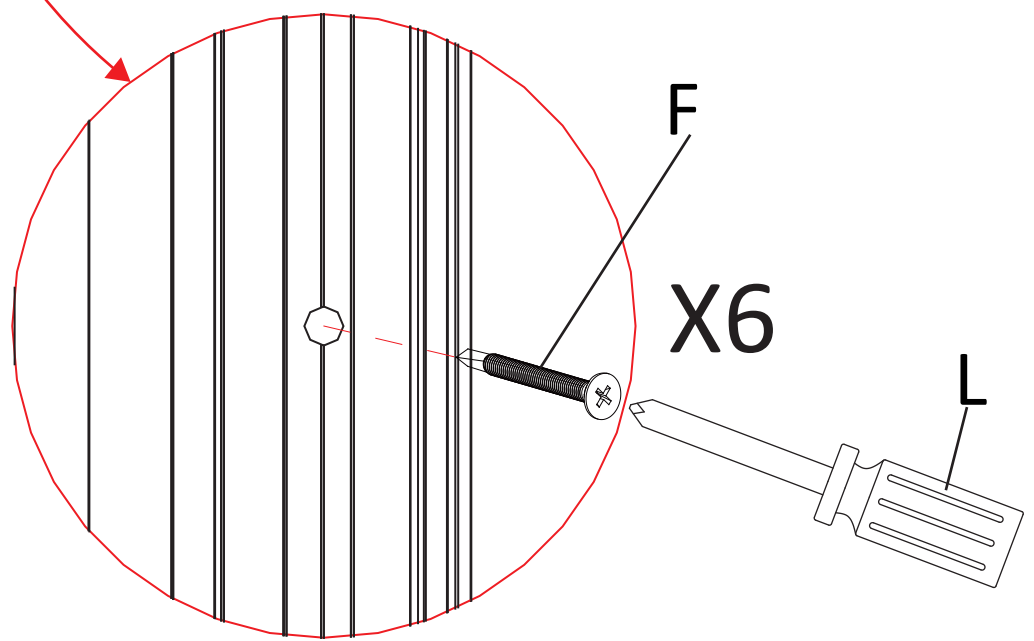
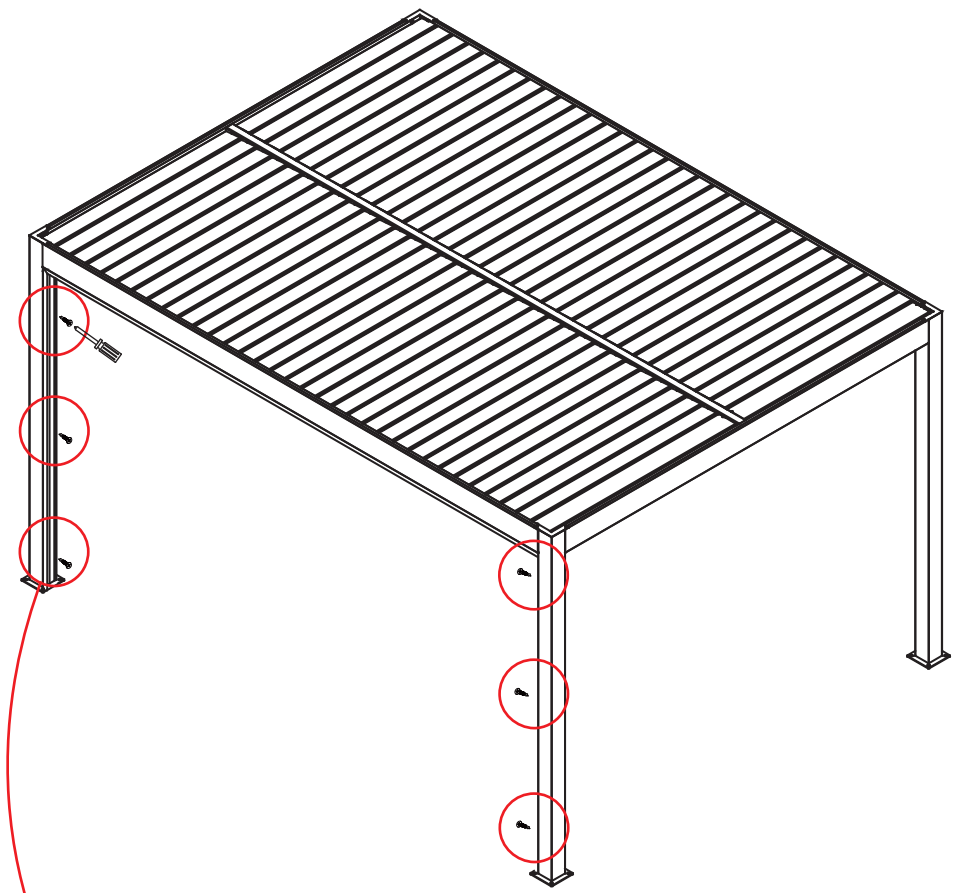

F		ST3.9x38	X6	L		X1
---	---	----------	----	---	---	----

8

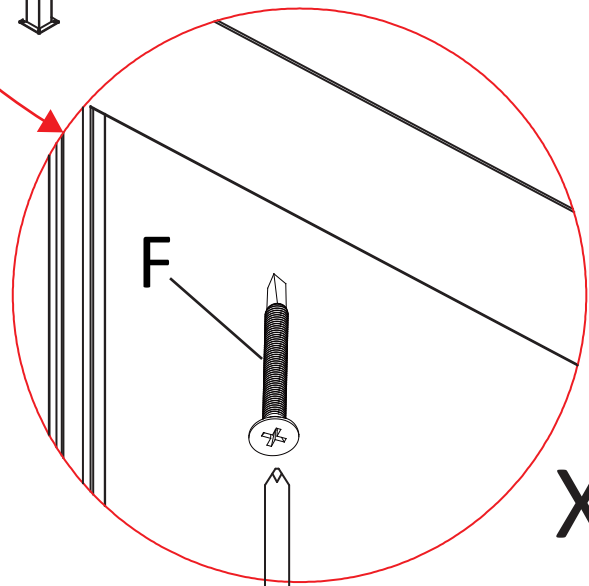
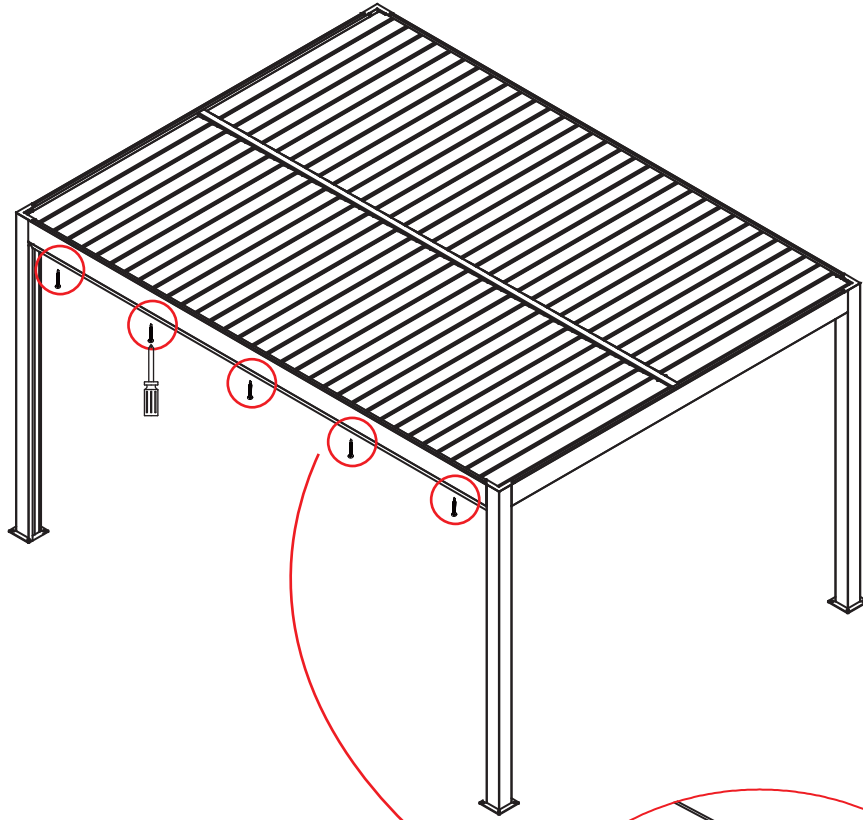

X5

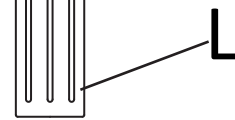
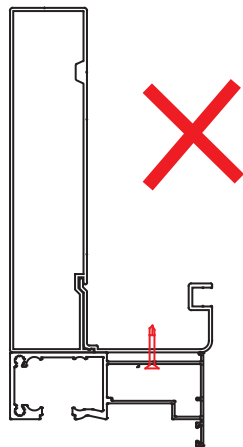
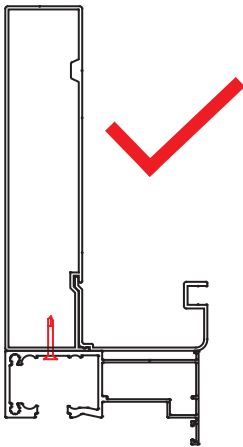

F		ST3.9x38	X5	L		X1
---	---	----------	----	---	---	----

9

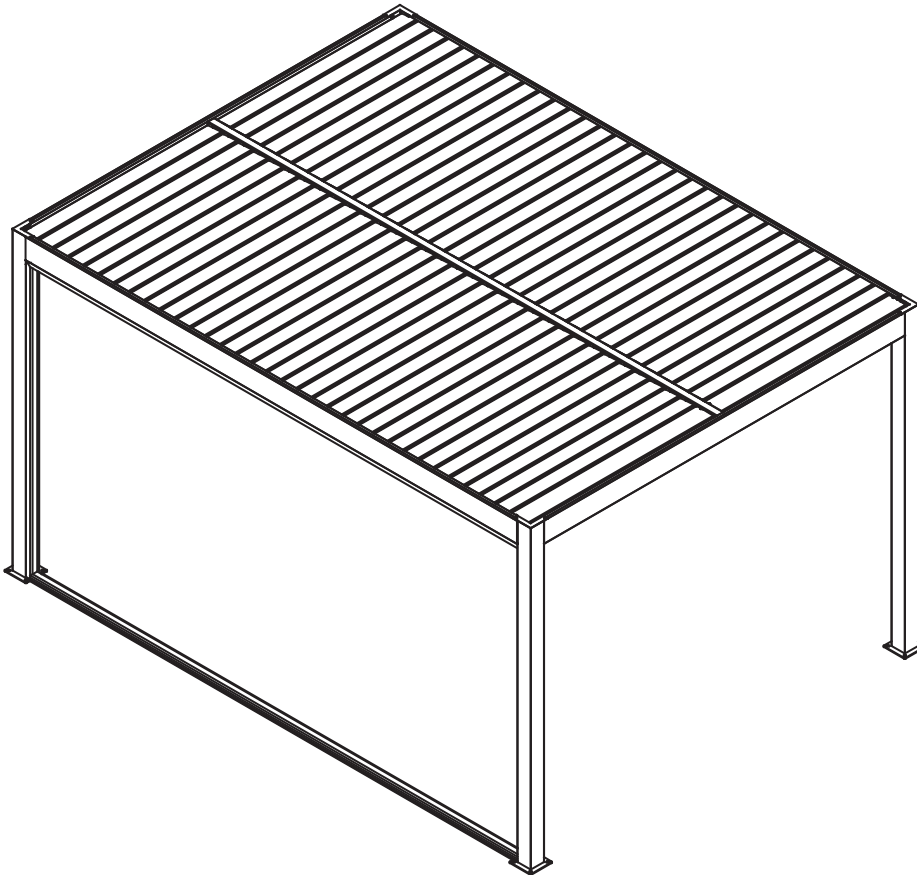
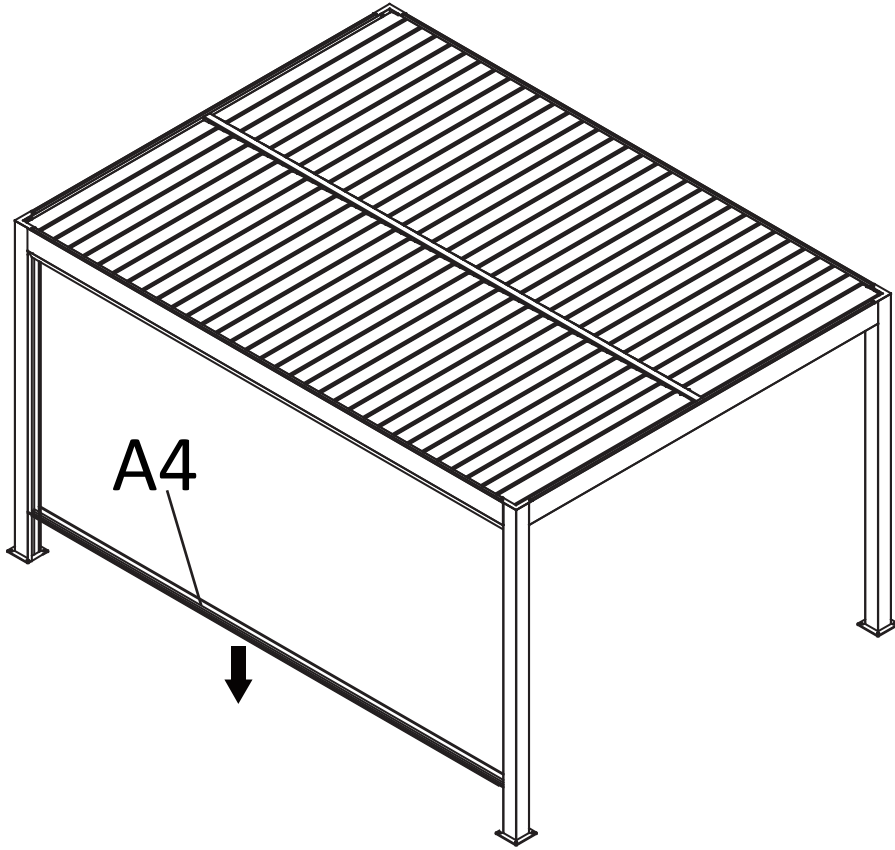

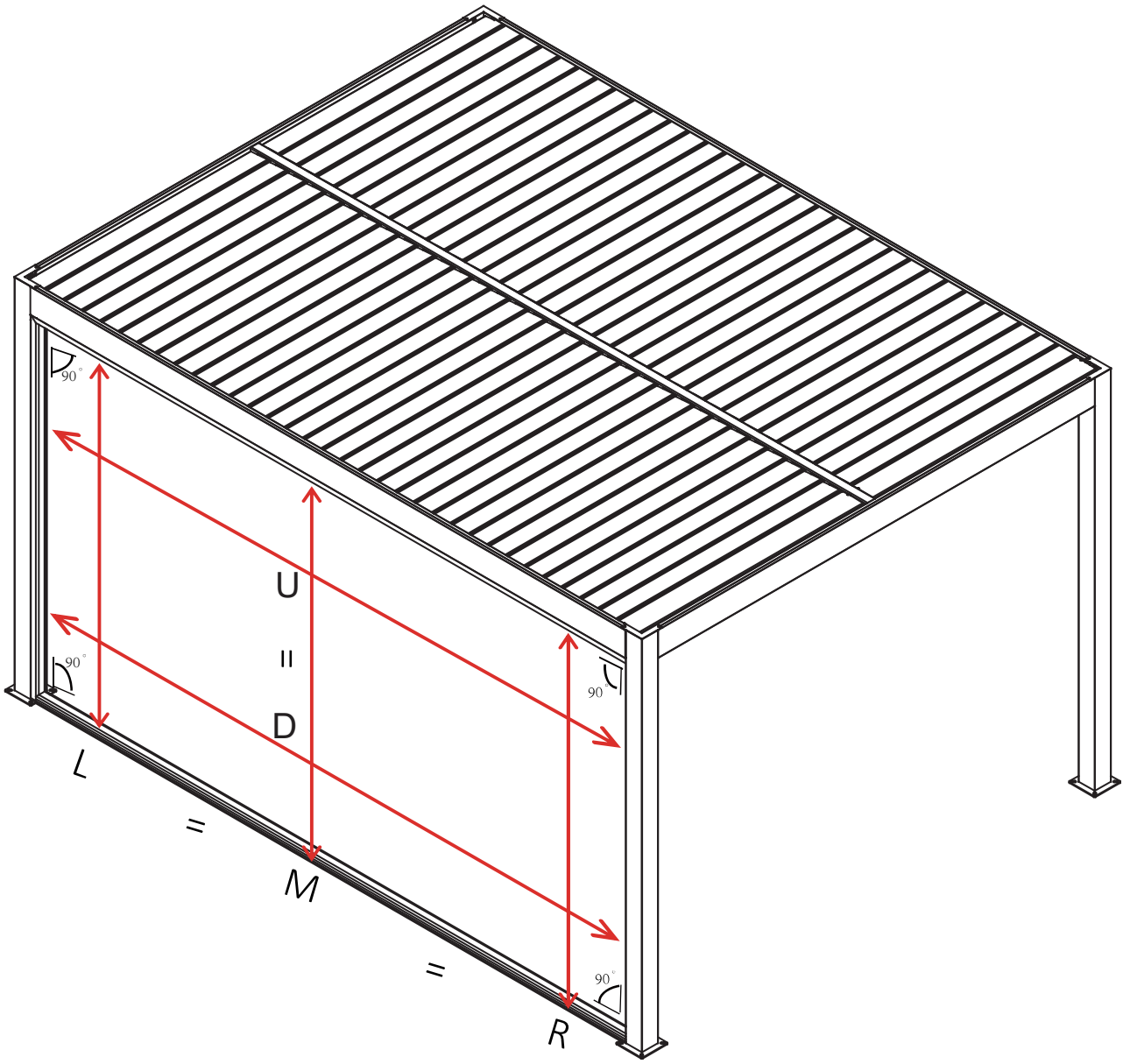

10

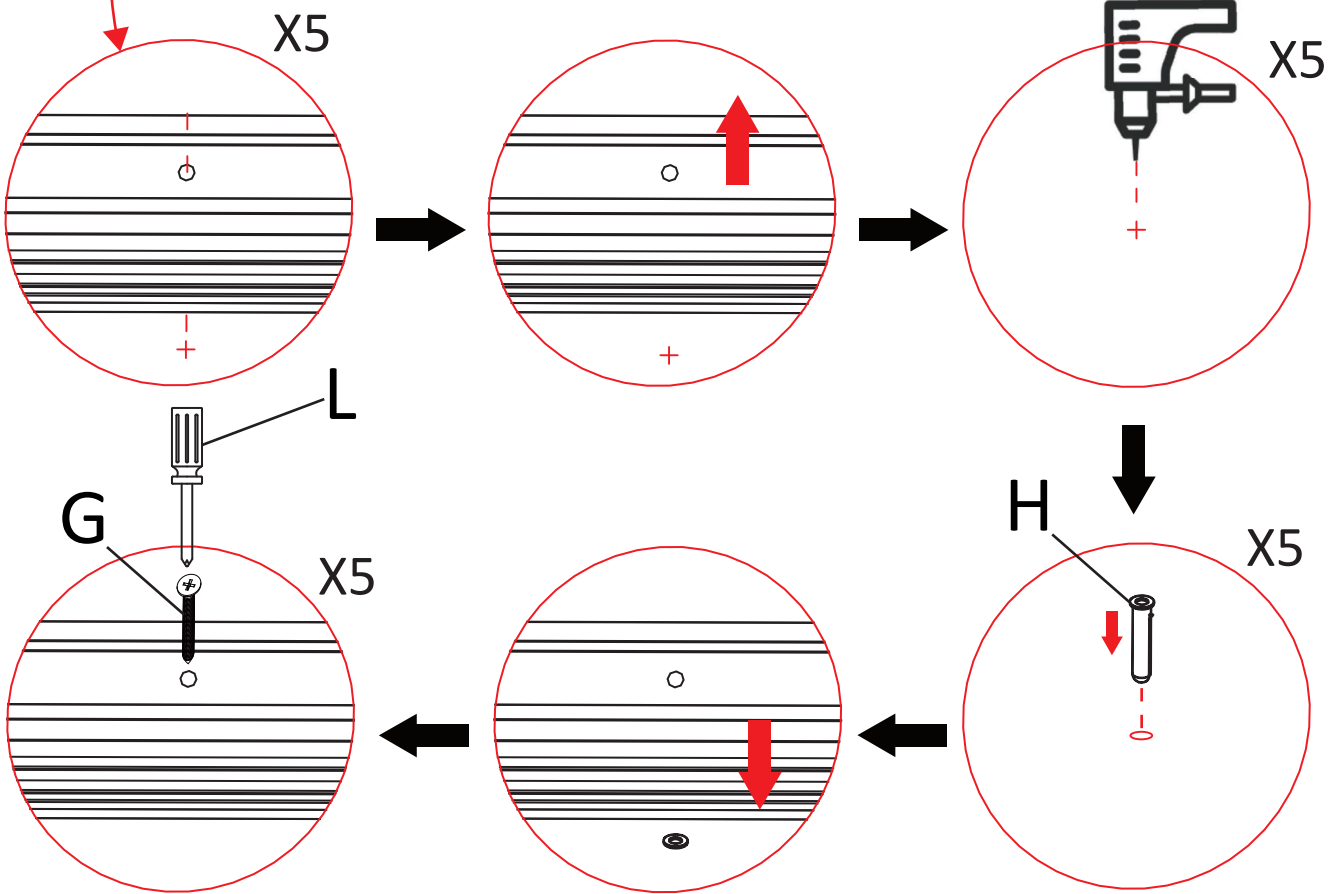
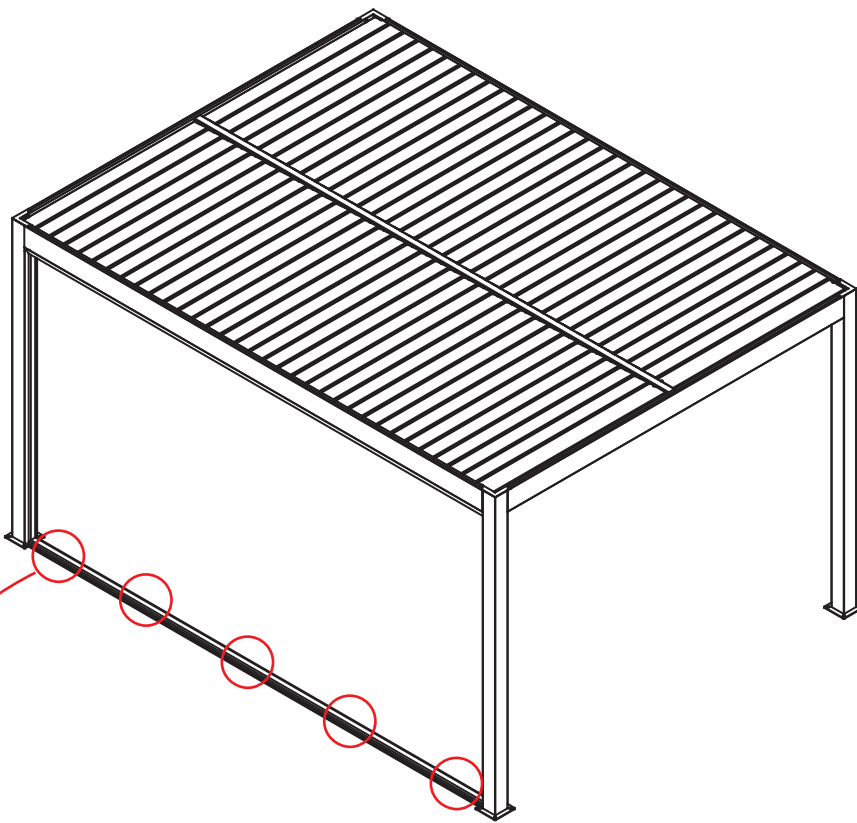

11

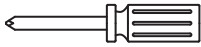

G	 ST4.8x60	X5
H	 M10x50	

L		X1
---	---	----

12

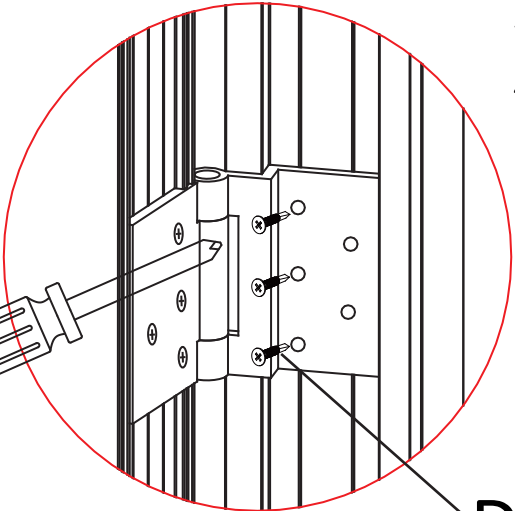
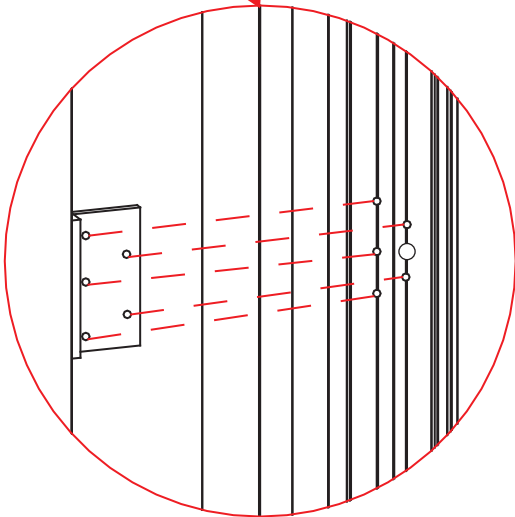
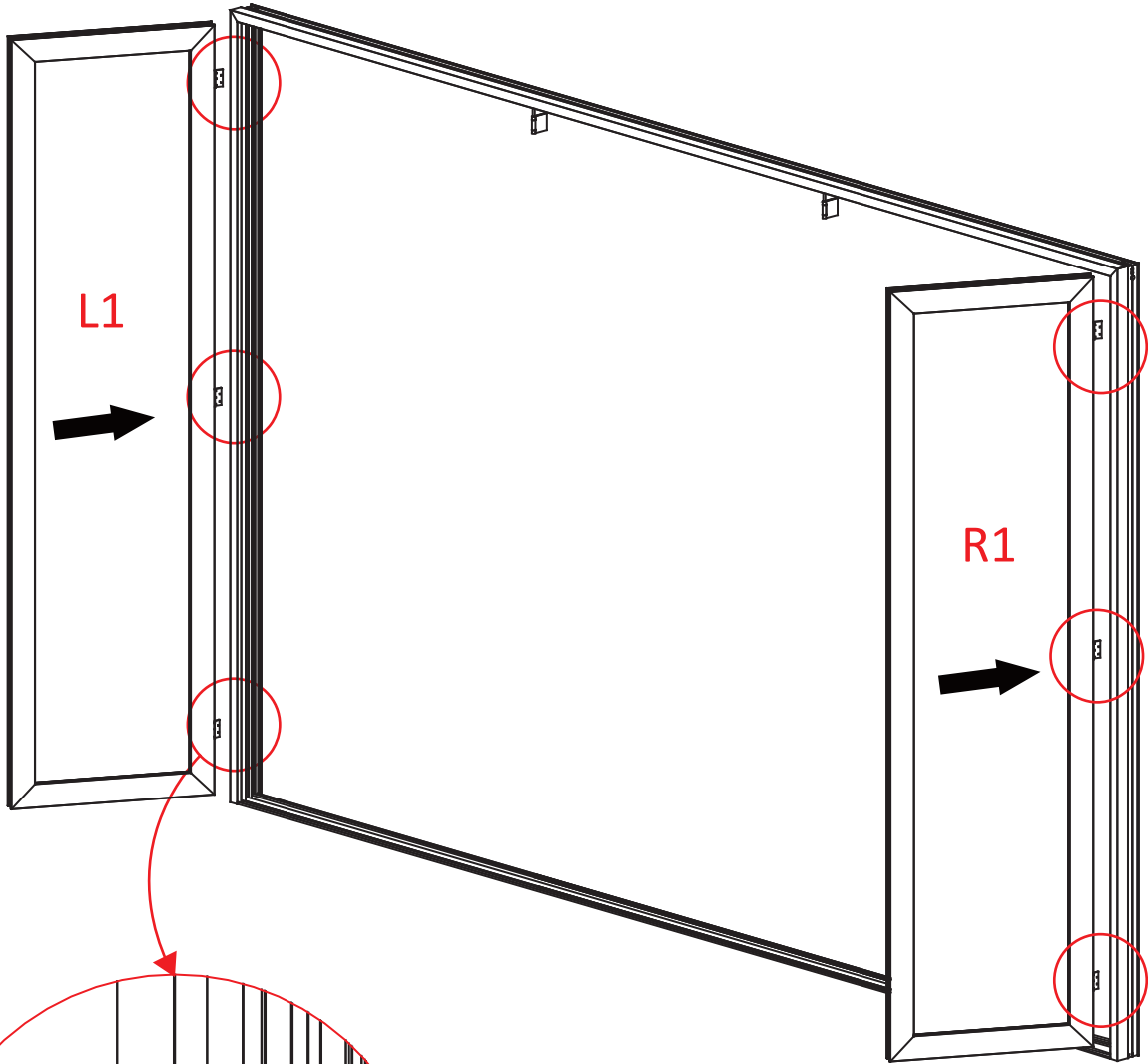

X6

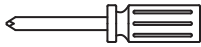
D		ST3.5x16	X18	L		X1
---	---	----------	-----	---	---	----

13

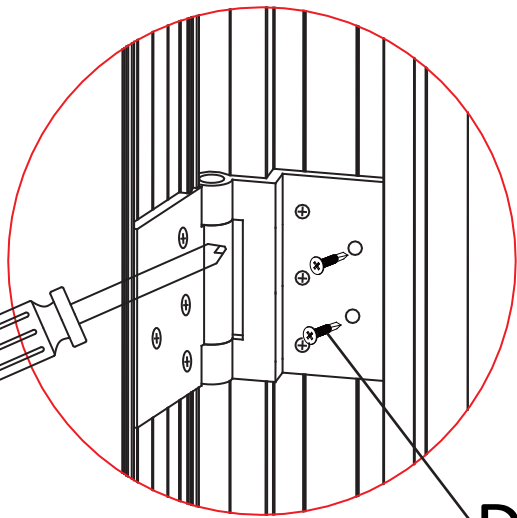
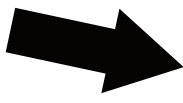
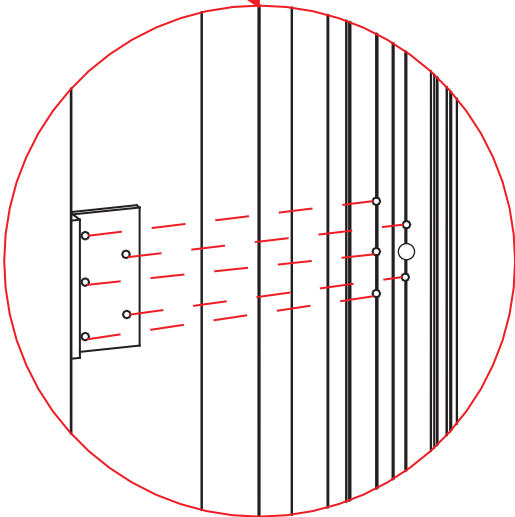
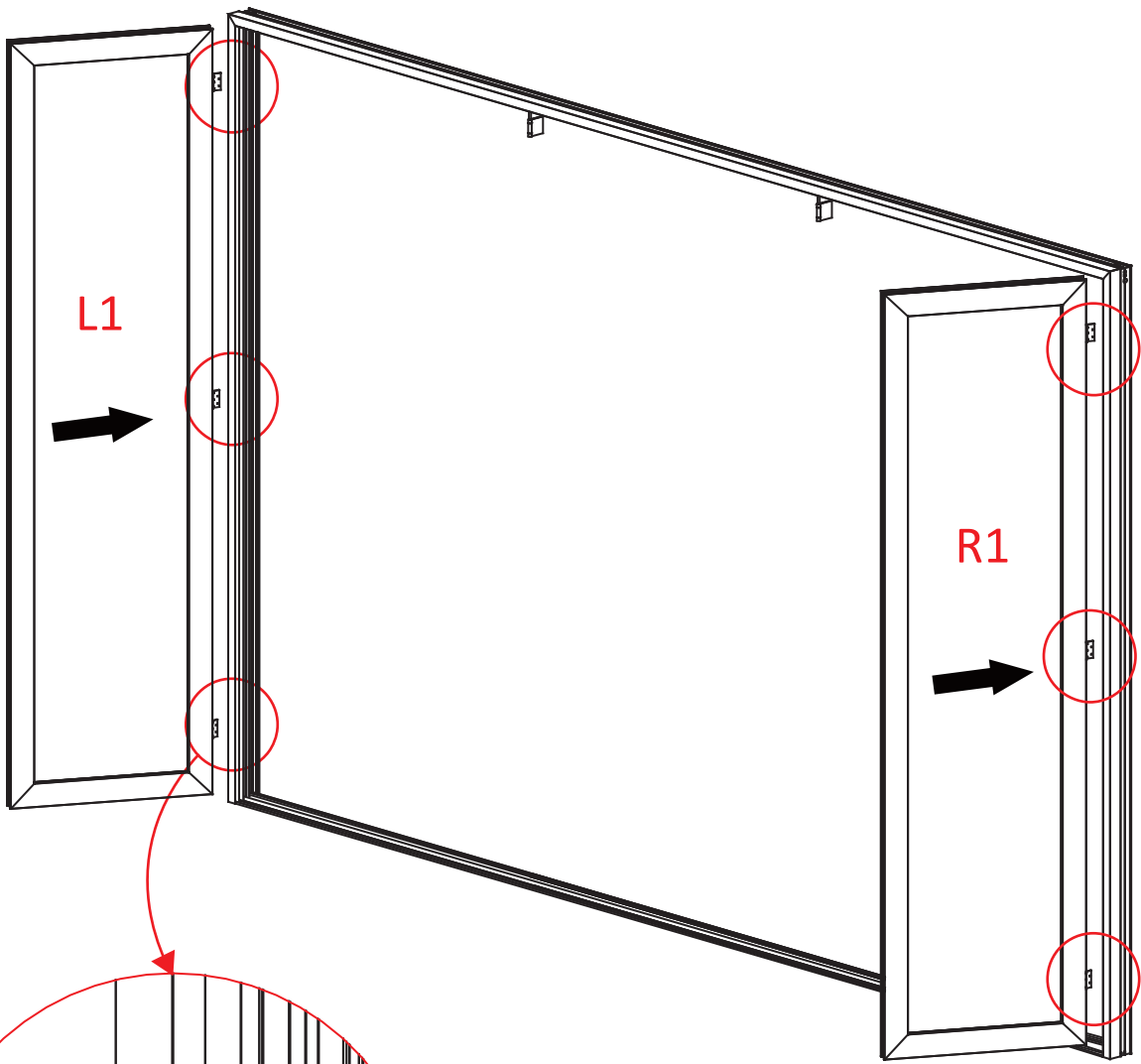

X6

L

D

D		ST3.5x16	X12	L		X1
---	---	----------	-----	---	---	----

14

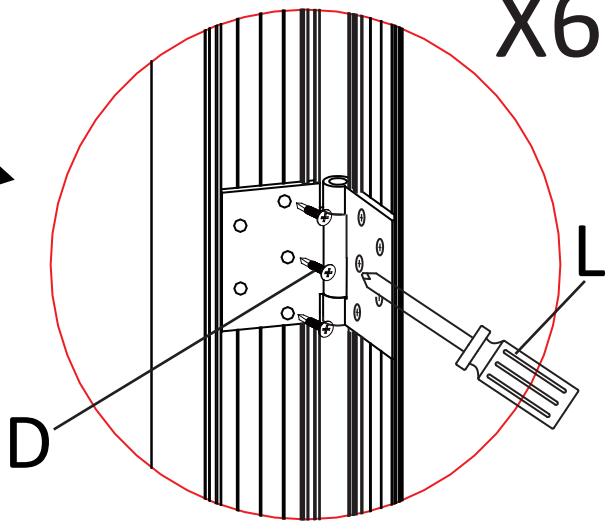
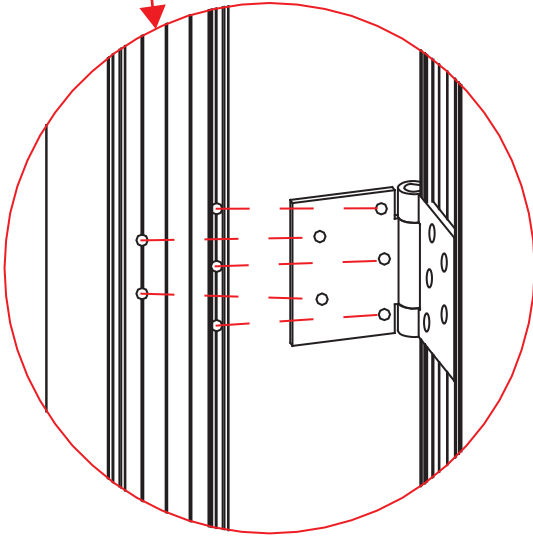
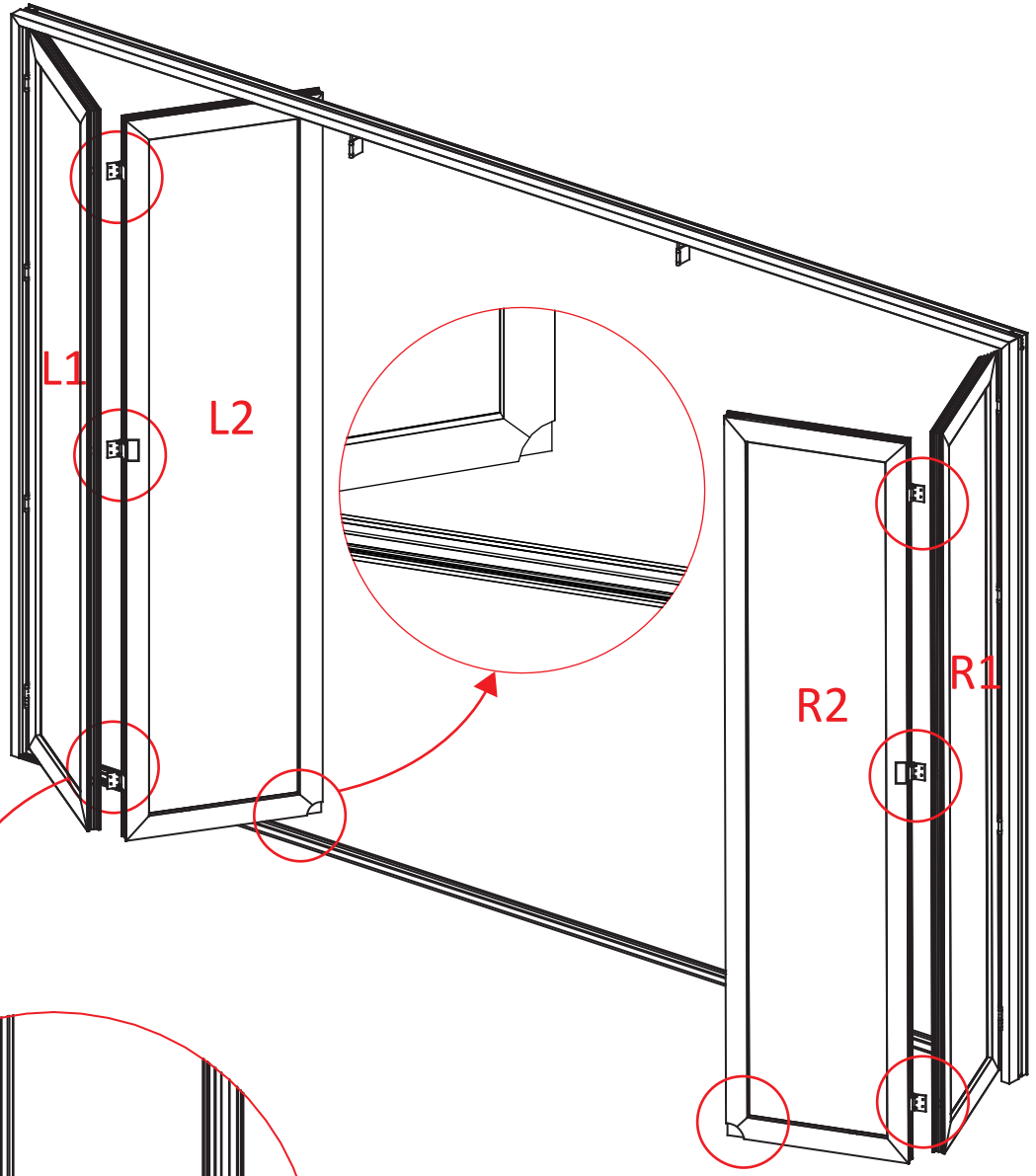

<b>D</b>		ST3.5x16	X18	<b>L</b>		X1
----------	---	----------	-----	----------	---	----

15

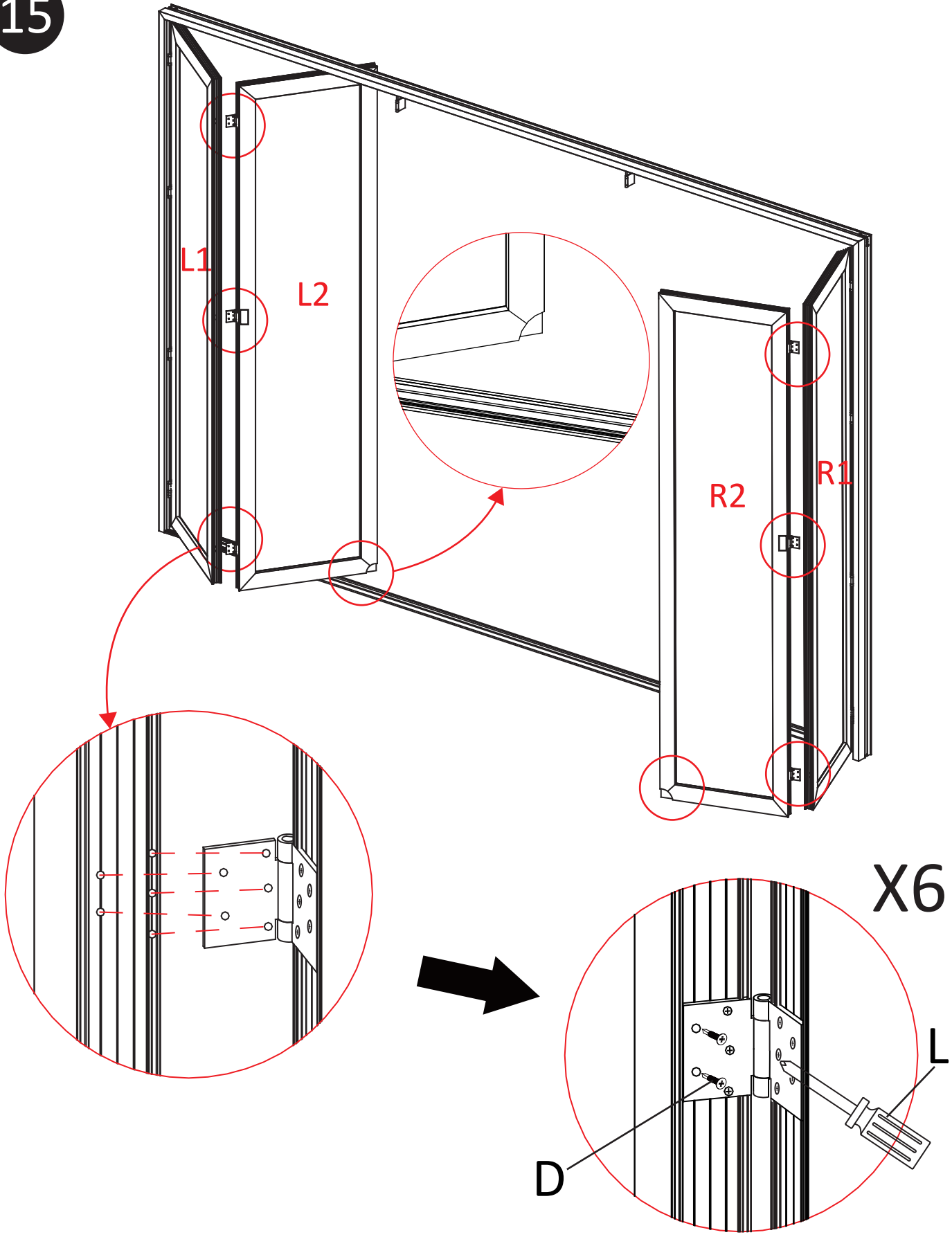

D		ST3.5x16	X12	L		X1
---	---	----------	-----	---	---	----

16

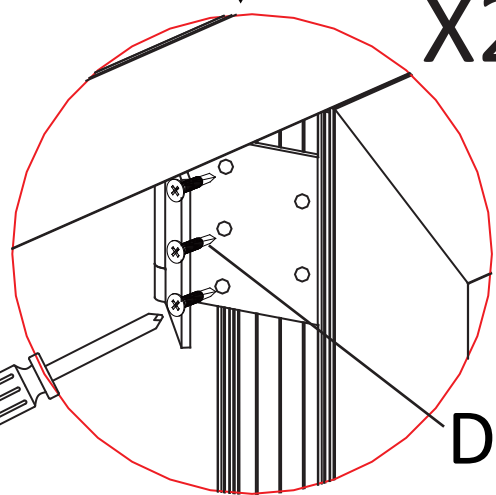
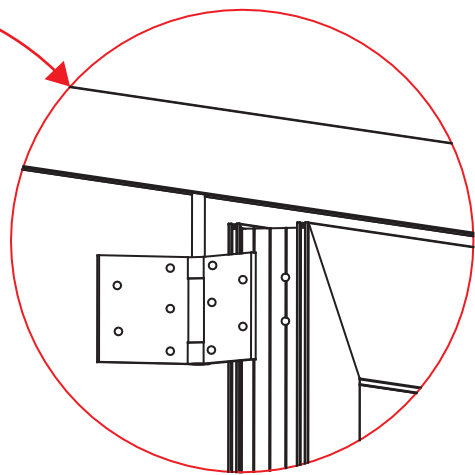
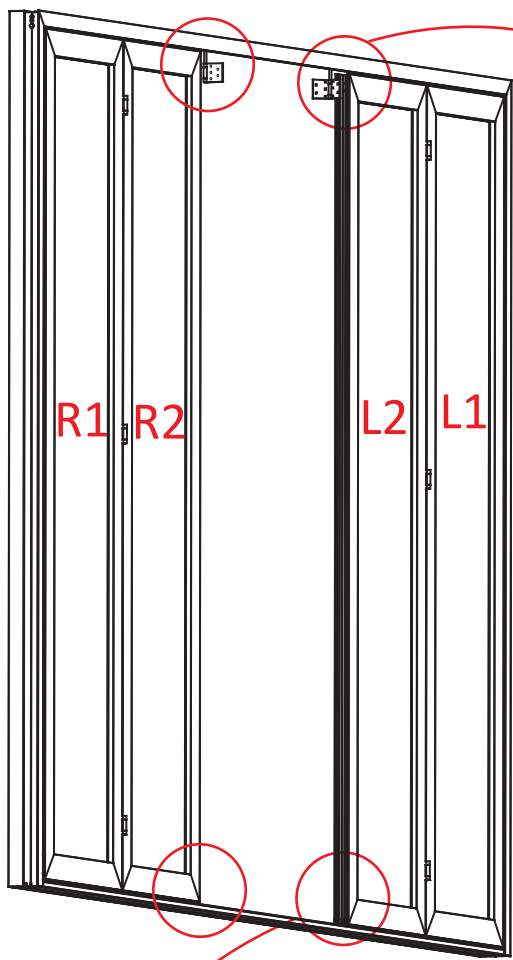

L

D

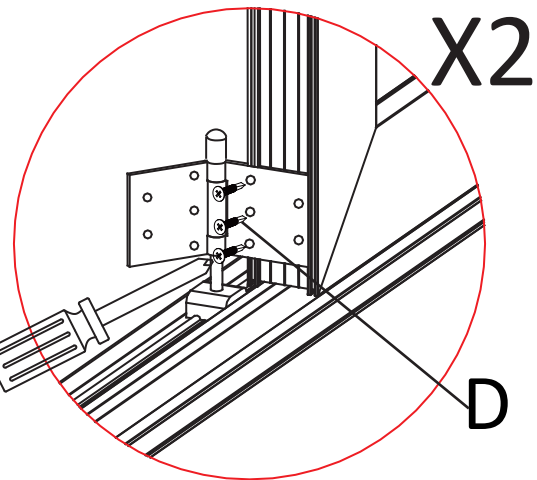
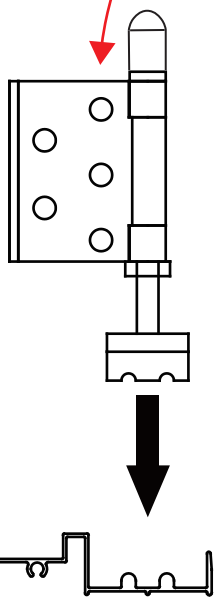

L

D

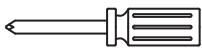
D	 ST3.5x16	X12
L		X1

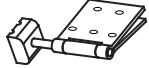
C		X2
---	---	----

17

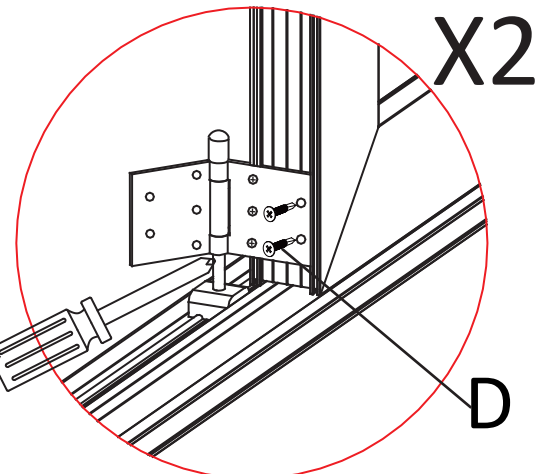
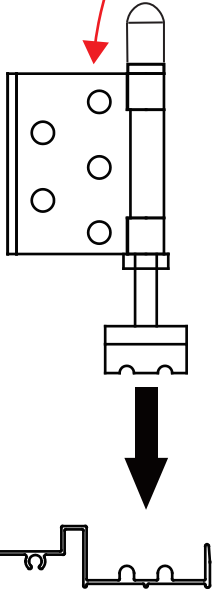
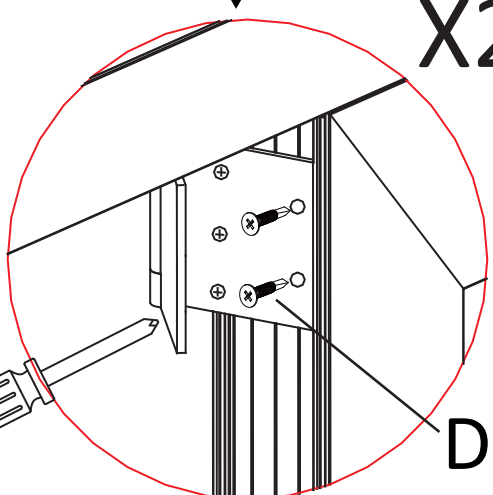
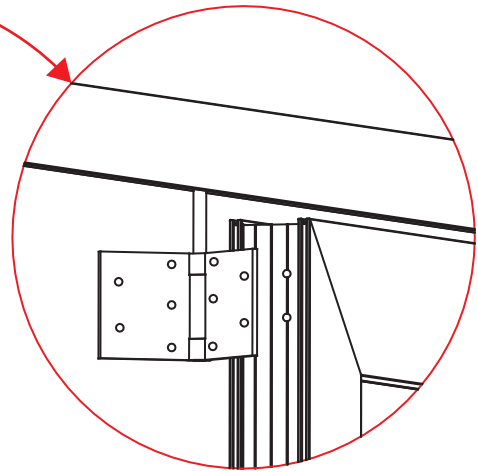
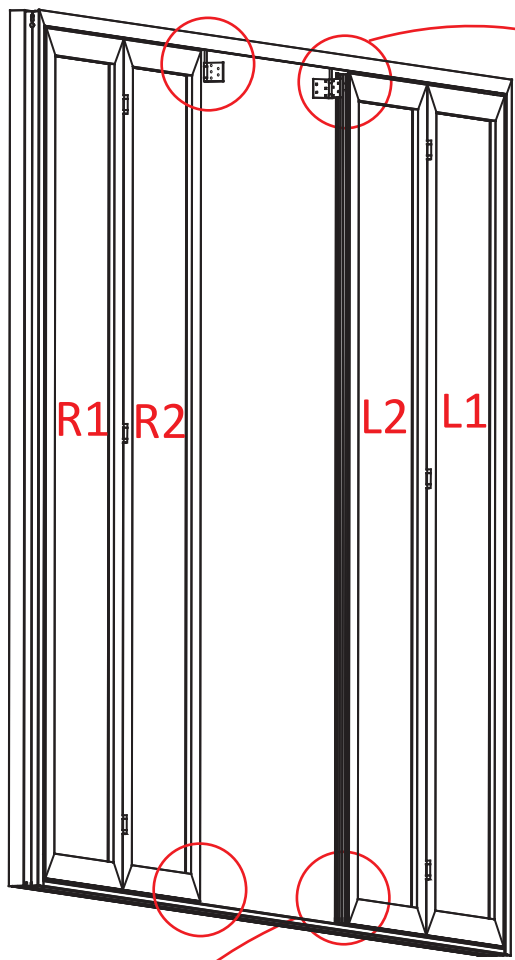

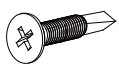
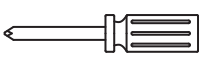
D	 ST3.5x16	X8
L		X1

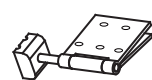
C		X2
---	---	----

18

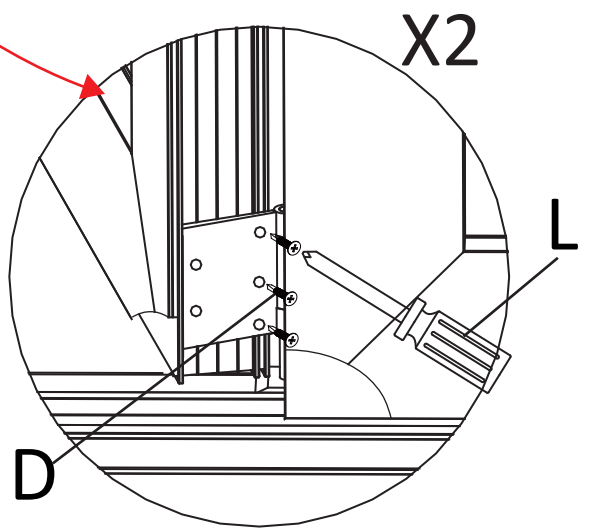
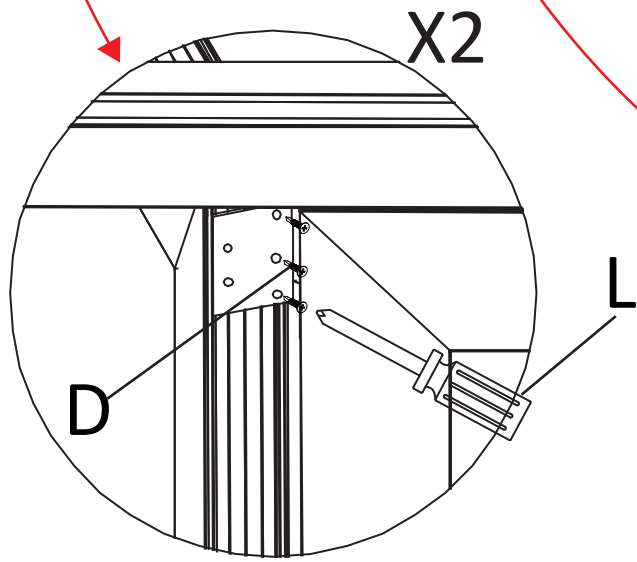
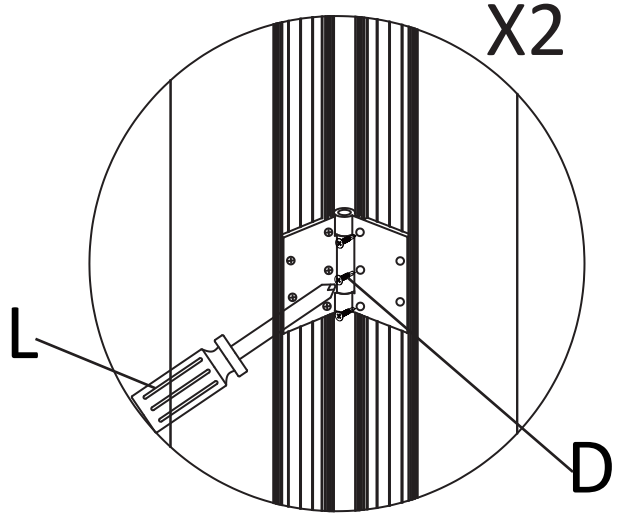
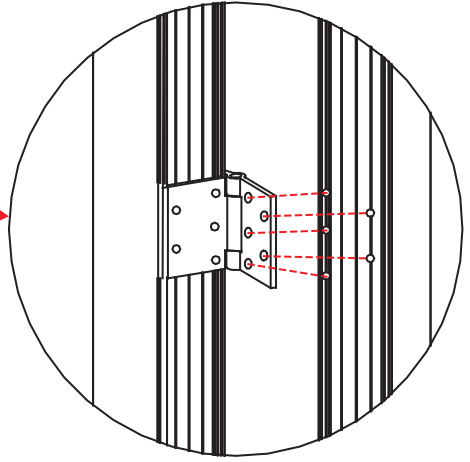
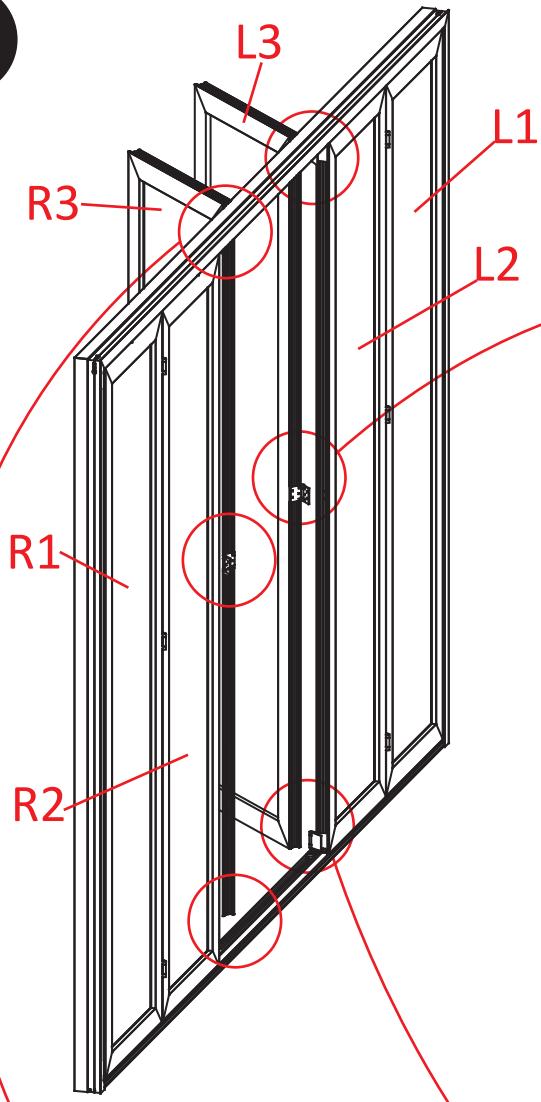

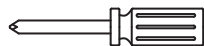
D		ST3.5x16	X18	L		X1
---	---	----------	-----	---	---	----

19

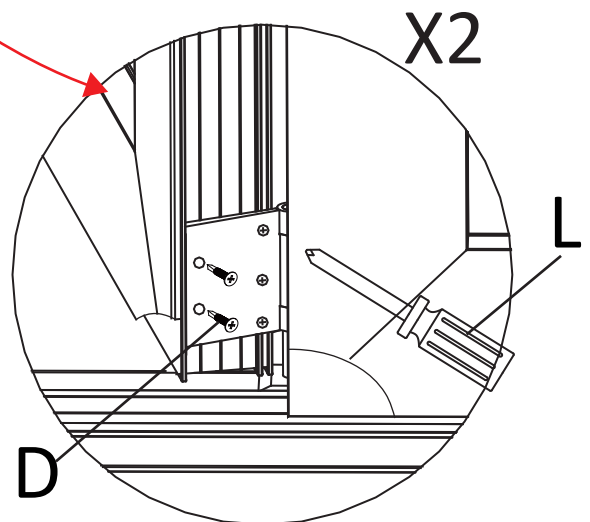
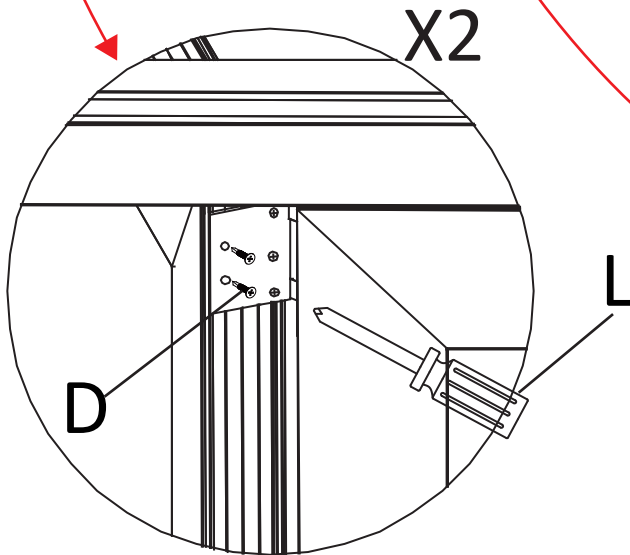
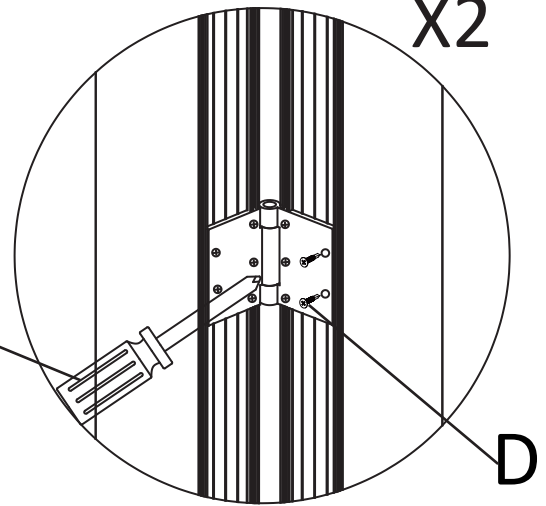
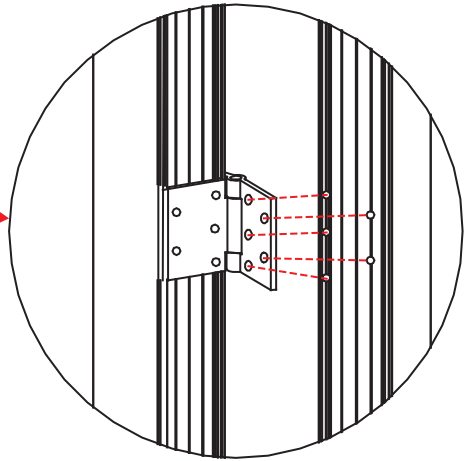
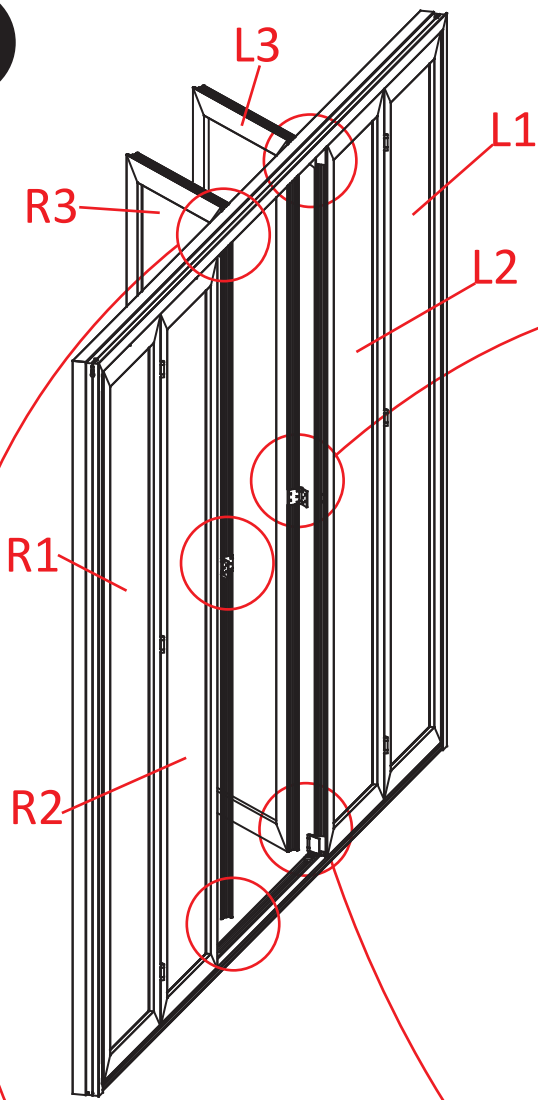

D



ST3.5x16

X12

L

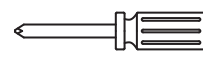



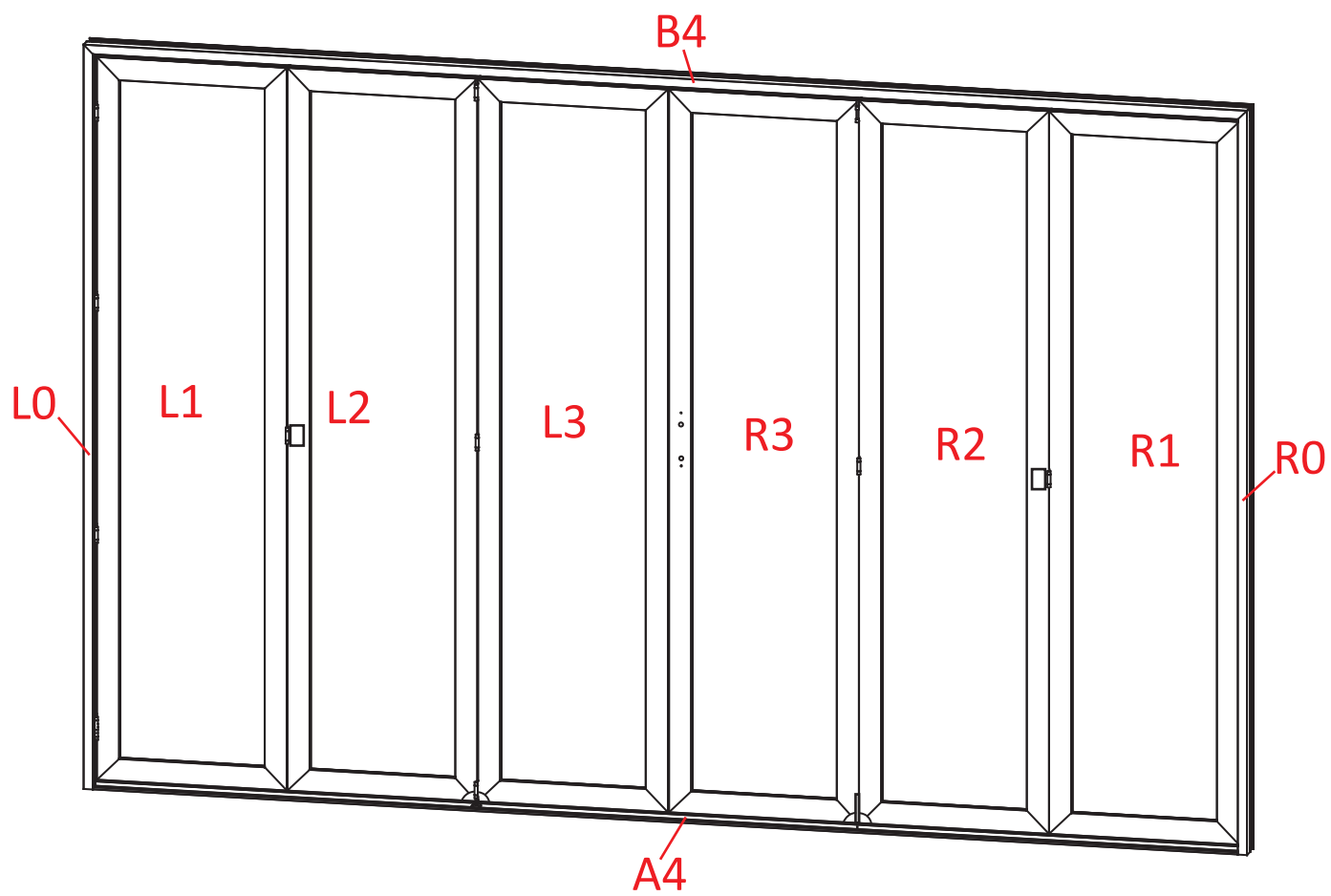

X1

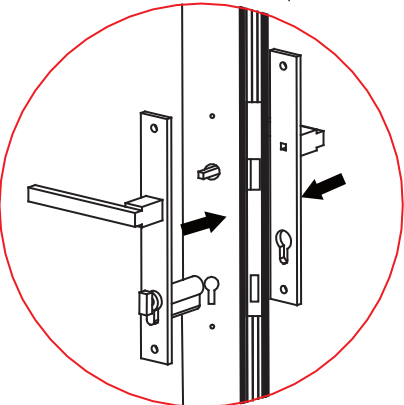
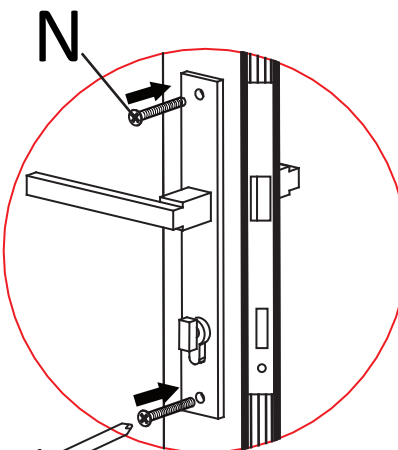
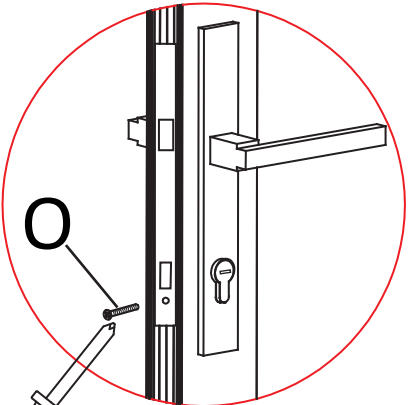
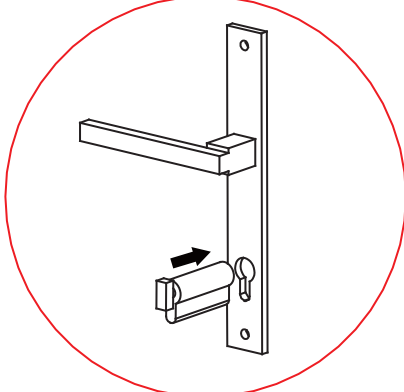
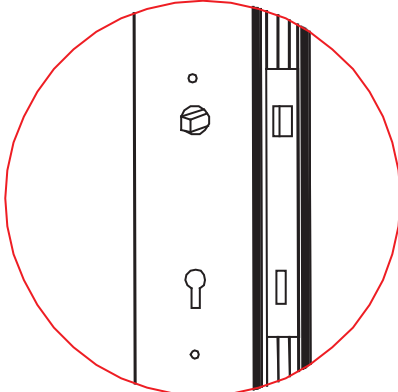
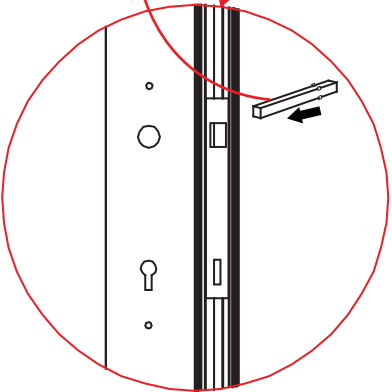
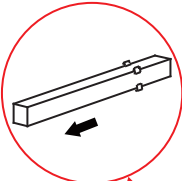
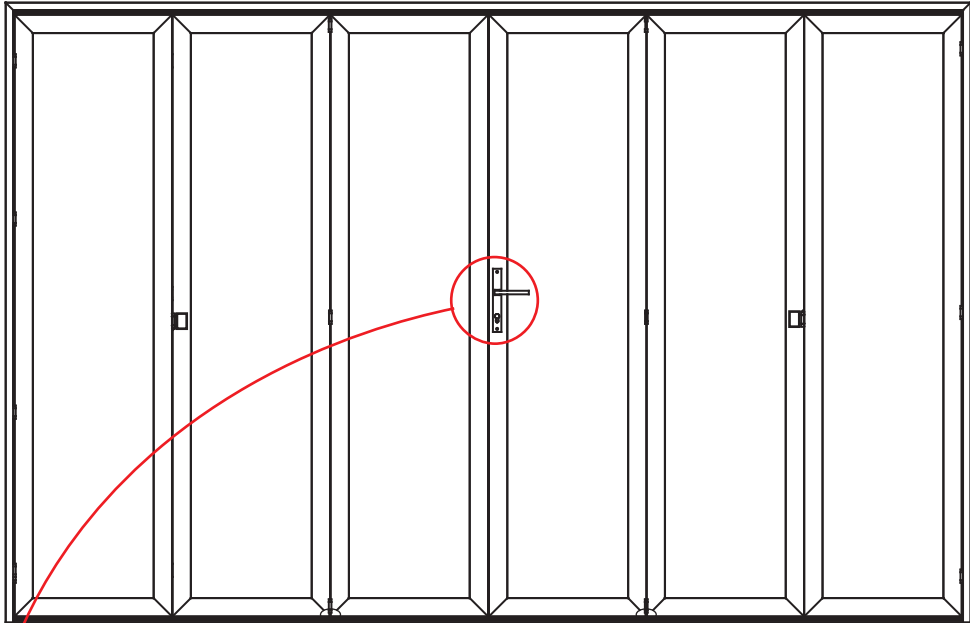

21

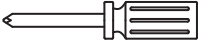

I		X1
N	 M5x50	X2
P		X2

L		X1
O	 M5x40	X1

22

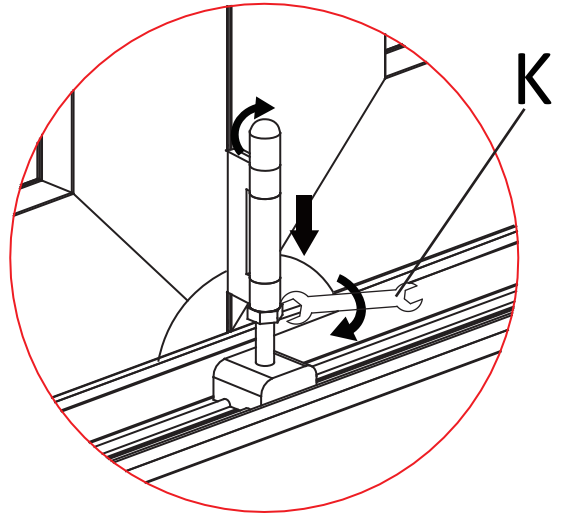
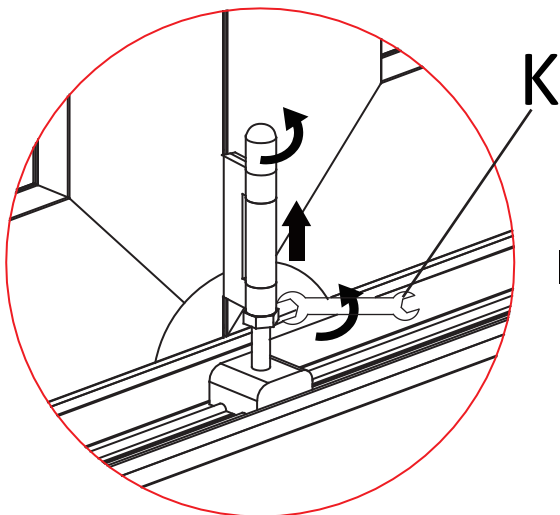
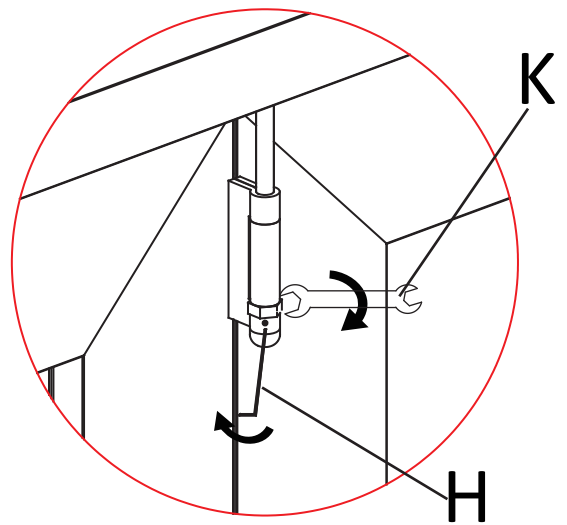
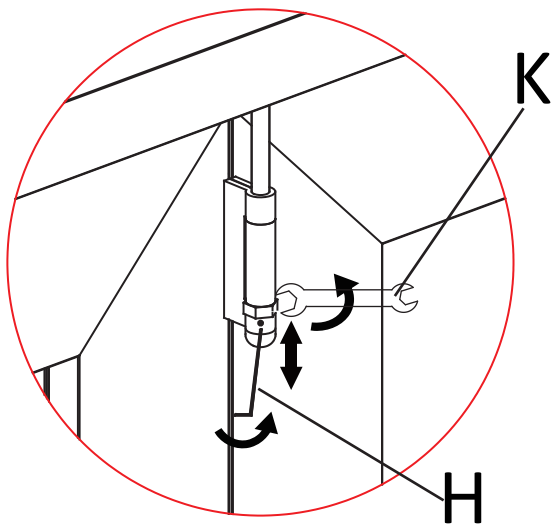
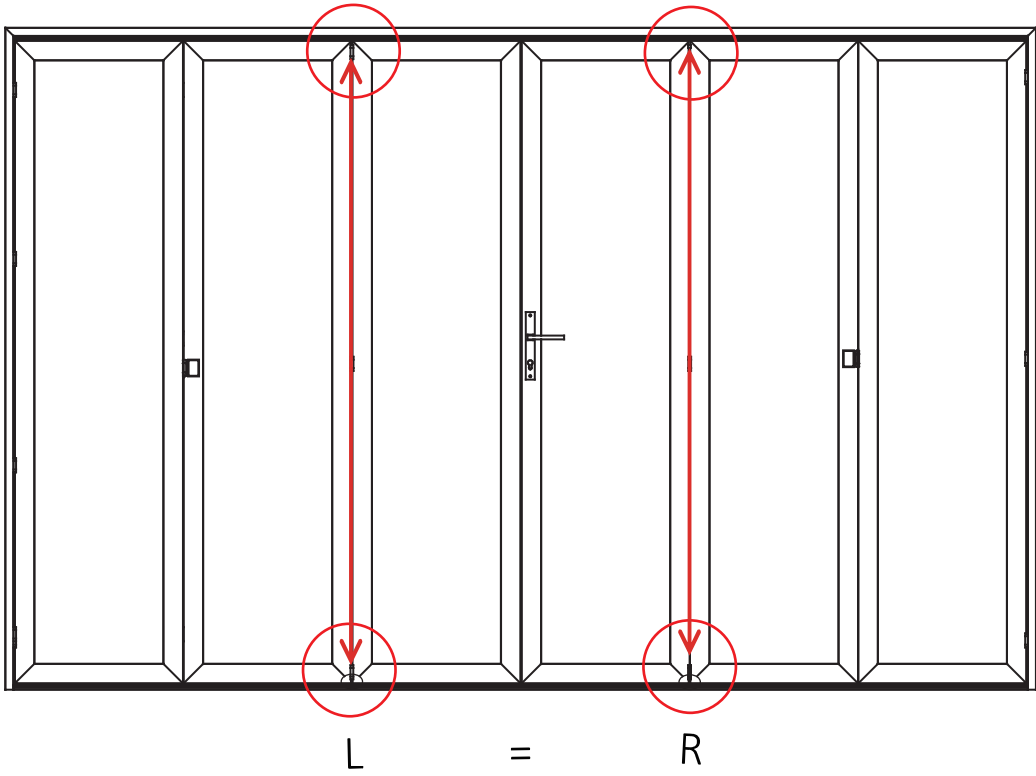

H	 L2	X1	K	 10-13mm	X1
---	--	----	---	---	----

23

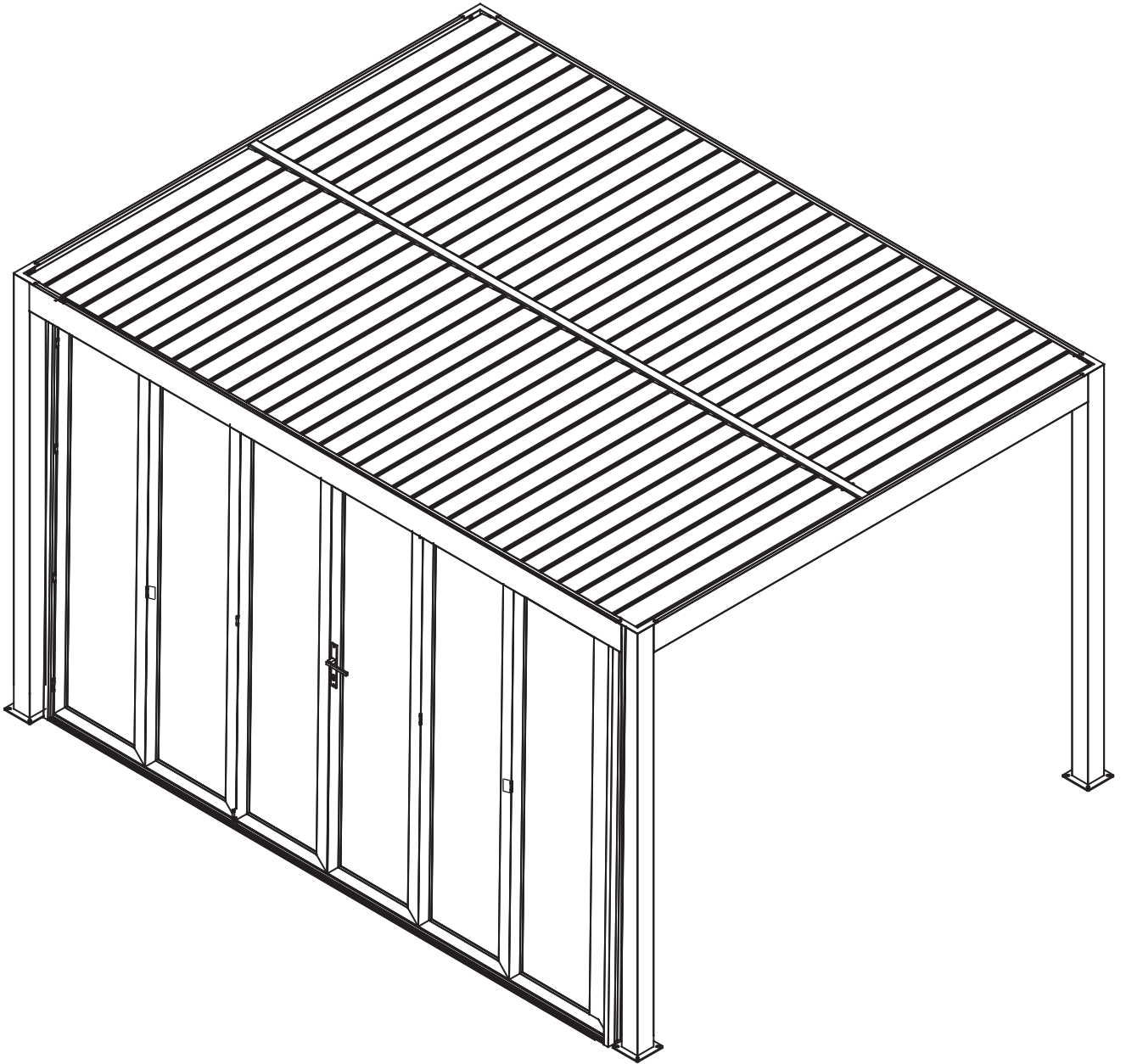

24

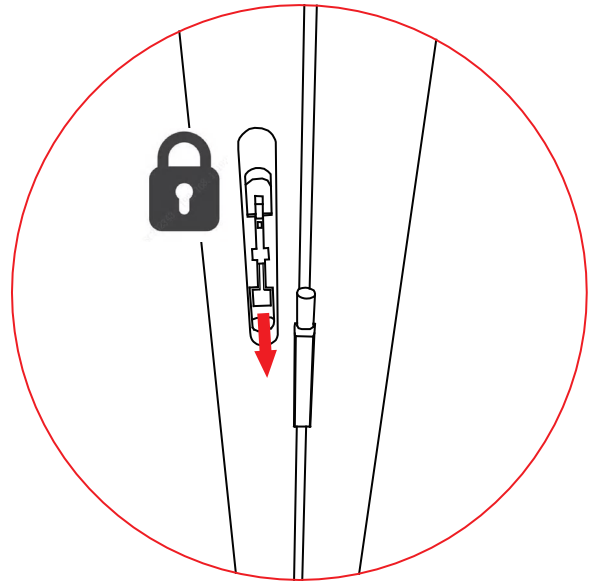
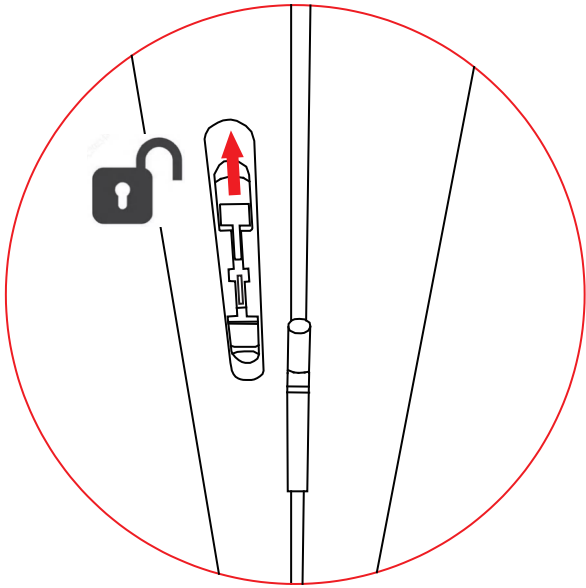
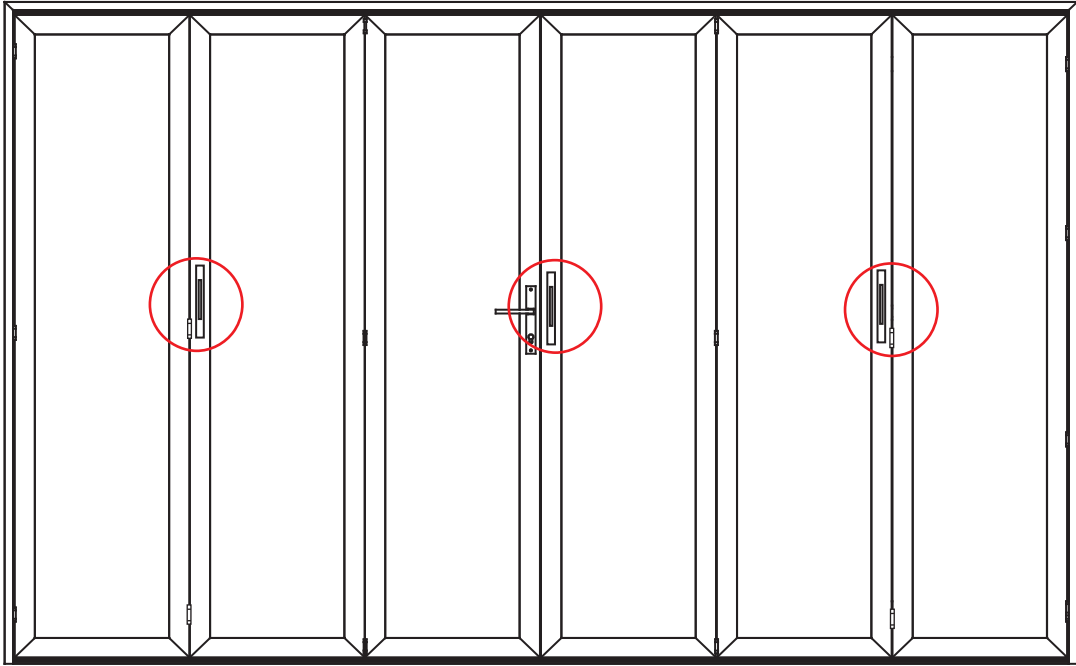



LED STRIP Protection class: Class III  
LED STRIP Environmental class: IP56  
Power supply Protection class: Class II  
Power supply Environmental class: IP67  
Power supply:  
INPUT: 110-250V  
OUTPUT: DC24V=6.25A

### Disposal of Waste Electrical and Electronic Equipment (WEEE)

This marking on the product or its packaging indicates that this product must not be disposed of with other household waste at the end of its working life.

To prevent possible harm to the environment or human health from uncontrolled waste disposal, and to promote the sustainable reuse of material resources, you are required by EU law to hand this equipment over to a designated collection point for the recycling of waste electrical and electronic equipment.

For more information about where you can drop off your waste equipment for recycling, please contact your local city office, your household waste disposal service, or the retailer where you purchased the product.

Material of Gazebo: Aluminium, tempered glass, textilene

Attention: A level installation site is essential, Please verify the ground is level in all directions prior to proceeding.

## Informationen zum Elektro- und Elektronikgerätegesetz 3 (ElektroG3)

### Symbolerklärung



Das Symbol des durchgestrichenen Müllimers besagt, dass dieses Elektro- bzw. Elektronikgerät am Ende seiner Lebensdauer nicht im Hausmüll entsorgt werden darf, sondern vom Endnutzer einer getrennten Sammlung zugeführt werden muss.

### Getrennte Erfassung von Altgeräten

Elektro- und Elektronikgeräte, die zu Abfall geworden sind, werden als Altgeräte bezeichnet. Besitzer von Altgeräten haben diese einer, vom unsortierten Siedlungsabfall getrennten, Erfassung zuzuführen. Altgeräte gehören insbesondere nicht in den Hausmüll, sondern in spezielle Sammel- und Rückgabesysteme.

### Batterien und Akkus sowie Lampen

Besitzer von Altgeräten haben Altbatterien und Altakkumulatoren, die nicht vom Altgerät umschlossen sind, sowie Lampen, die zerstörungsfrei aus dem Altgerät entnommen werden können, im Regelfall vor der Abgabe an einer Erfassungsstelle vom Altgerät zu trennen. Dies gilt nicht, soweit Altgeräte einer Vorbereitung zur Wiederverwendung unter Beteiligung eines öffentlich-rechtlichen Entsorgungsträgers zugeführt werden.

### Möglichkeiten der Rückgabe von Altgeräten

Besitzer von Altgeräten aus privaten Haushalten können diese bei den Sammelstellen der öffentlich-rechtlichen Entsorgungsträger oder bei den von Herstellern oder Vertreibern im Sinne des ElektroG eingerichteten Rücknahmestellen unentgeltlich abgeben. Zur Rückgabe stehen in Ihrer Nähe kostenfreie Sammelstellen für Elektroaltgeräte sowie gegebenenfalls weitere Annahmestellen für die Wieder-Verwendung der Geräte zur Verfügung. Die Adressen können Sie von Ihrer Stadt- bzw. Kommunalverwaltung erhalten. Auch Vertreter mit einer Verkaufsfläche für Elektro- und Elektronikgeräte von mindestens 400 Quadratmetern sowie Vertreter von Lebensmitteln mit einer Gesamtverkaufsfläche von mindestens 800 Quadratmetern, die mehrmals im Kalenderjahr oder dauerhaft Elektro- und Elektronikgeräte anbieten und auf dem Markt bereitstellen, sind verpflichtet unentgeltlich alte Elektro- und Elektronikgeräte zurückzunehmen. Diese müssen bei der Abgabe eines neuen Elektro- oder Elektronikgerätes an einen Endnutzer ein Altgerät des Endnutzers der gleichen Geräteart, das im Wesentlichen die gleichen Funktionen wie das neue Gerät erfüllt, am Ort der Abgabe oder in unmittelbarer Nähe hierzu unentgeltlich zurückzunehmen sowie ohne Kauf eines Elektro- oder Elektronikgerätes auf Verlangen des Endnutzers bis zu drei Altgeräte pro Geräteart, die in keiner äußeren Abmessung größer als 25 Zentimeter sind, im Einzelhandelsgeschäft oder in unmittelbarer Nähe hierzu unentgeltlich zurückzunehmen. Bei einem Vertrieb unter Verwendung von Fernkommunikationsmitteln gelten als Verkaufsflächen des Vertreibers alle Lager- und Versandflächen.

### Datenschutzhinweis

Sofern das alte Elektro- bzw. Elektronikgerät personenbezogene Daten enthält, sind Sie selbst für deren Löschung verantwortlich, bevor Sie es zurückgeben. Sofern dies ohne Zerstörung des alten Elektro- oder Elektronikgerätes möglich ist, entnehmen Sie diesem bitte alte Batterien oder Akkus sowie Altlampen, bevor sie es zur Entsorgung zurückgeben, und fuhren diese einer separaten Sammlung zu.

## **Weitere Informationen**

Weitere Informationen zum Elektroggesetz finden Sie auf [www.elektroggesetz.de](http://www.elektroggesetz.de). Informationen zur Erfüllung der quantitativen Zielvorgaben nach § 10 Abs. 3 ElektroG (Sammelquote) und § 22 Abs. 1 ElektroG (Verwertungsquoten):

Das Bundesministerium für Umwelt, Naturschutz, nukleare Sicherheit und Verbraucherschutz veröffentlicht jährlich ausführliche Daten zu Elektro- und Elektronikgeräten und die in Deutschland erreichten und an die EU-Kommission zu übermittelnden quantitativen Zielvorgaben auf seiner Internetseite:

<https://www.bmu.de/themen/wasser-ressourcenabfall/kreislaufwirtschaft/statistiken/elektro-und-elektronikaltgeraete>.

## **Hinweise zur Abfallvermeidung**

Nach den Vorschriften der Richtlinie 2008/98/EU über Abfälle und ihrer Umsetzung in den Gesetzgebungen der Mitgliedstaaten der Europäischen Union haben Maßnahmen der Abfallvermeidung grundsätzlich Vorrang vor Maßnahmen der Abfallbewirtschaftung. Als Maßnahmen der Abfallvermeidung kommen bei Elektro- und Elektronikgeräten insbesondere die Verlängerung ihrer Lebensdauer durch Reparatur defekter Geräte und die Veräußerung funktionstüchtiger gebrauchter Geräte anstelle ihrer Zuführung zur Entsorgung in Betracht. Weitere Informationen enthält das Abfallvermeidungsprogramm des Bundes unter Beteiligung der Länder:

<https://www.bmu.de/publikation/abfallvermeidungsprogramm-desbundesunter-beteiligung-der-laender/>

## **WEEE-Registrierungsnummer und Kontaktdaten**

Unter der WEEE-Registrierungsnummer DE 76956000 sind wir bei  
XXXLutz KG  
Roemerstrasse 39 AT-4600 Wels Austria,  
als Händler und Inverkehrbringer von Elektro- und Elektronikgeräten registriert.

E-Mail-Adresse:

[info@xxxlutz.at](mailto:info@xxxlutz.at)