

REPC-Nr.:

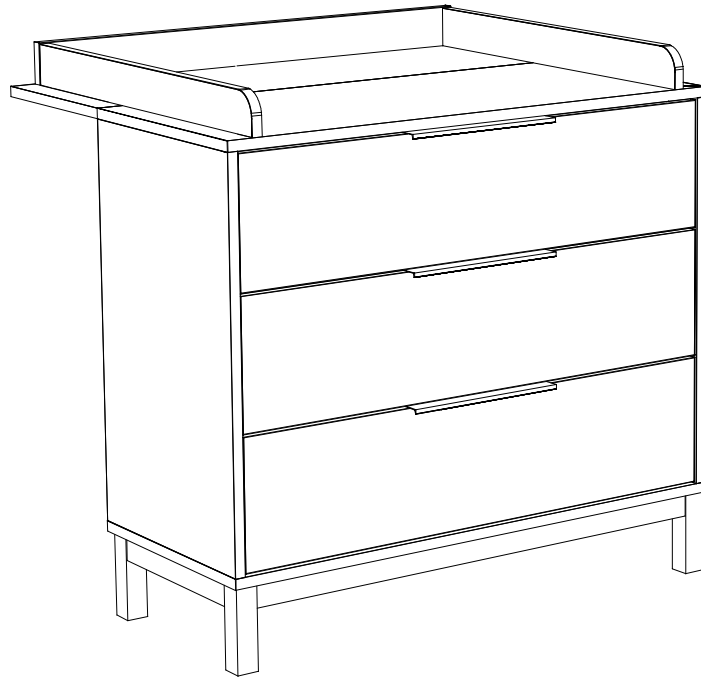

Artikel.-Nr.:

**4004-Wiko-03**

Montageanleitung.-Nr.:

**MA1-00828**

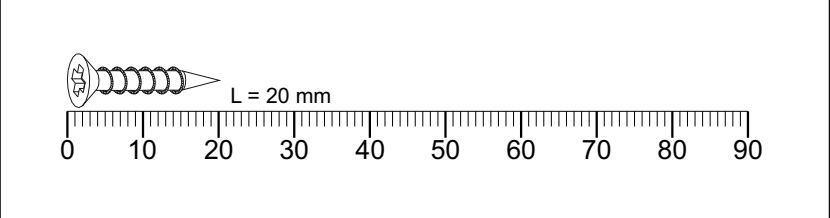
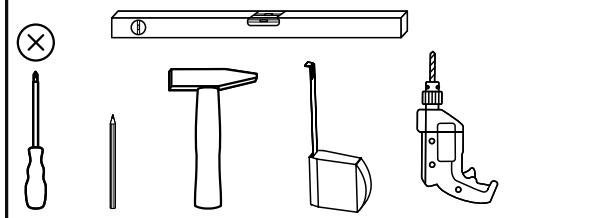
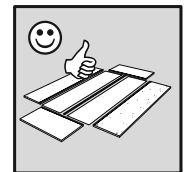
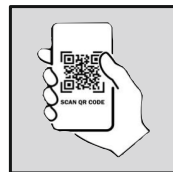
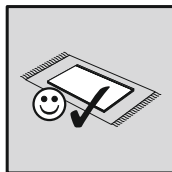
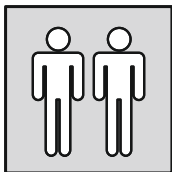
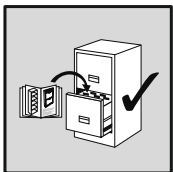

SCAN ME

Das Ersatzteil-Anforderungsformular finden Sie auf  
The replacement parts requisition form you find on  
<https://www.mausbacher.de/ersatzteile/>

## Colli 1/2

### BT1-00913

B01-10		B01-122		B01-174	
13x	6,3x50	6x	4x13	7x	4,5x50
B01-189		B01-200		B01-30	
4x	M4x10	18x	6,3x13	30x	3x16
B01-352		B01-90		B02-10	
4x	M4	4x	3,5x20	14x	ø15x12mm
B02-20		B02-103		B02-142	
14x		8x	8x30	2x	45x12
B05-185		B08-80			
4x		1x			

### BT1-00914

B05-01		B06-423	
2x	ø14mm	3x	300mm
B02-10		B02-20	
12x	ø15x12mm	12x	
B02-103		B05-02	
24x	8x30	12x	ø20mm

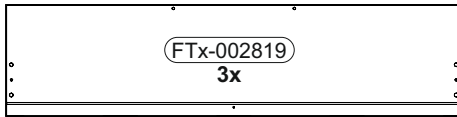

964 x 236

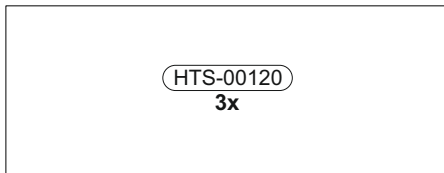

938 x 358

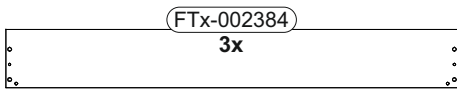

957 x 124

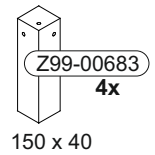
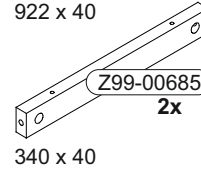
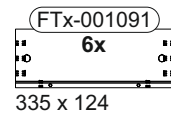
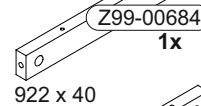
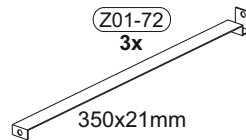
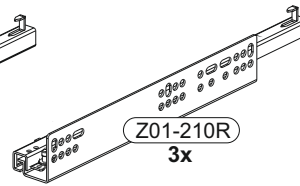
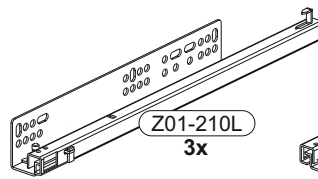

## Colli 2/2

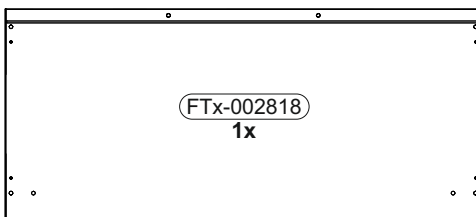

1007 x 444

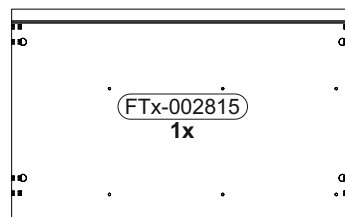

724 x 444

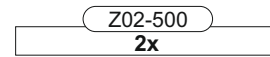

500 x 50

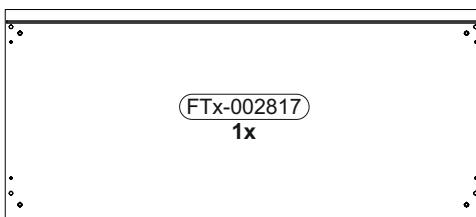

1007 x 444

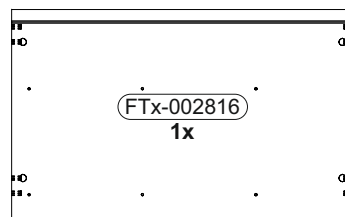

724 x 444

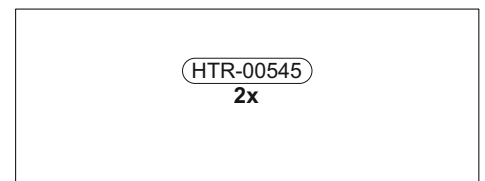

980 x 368

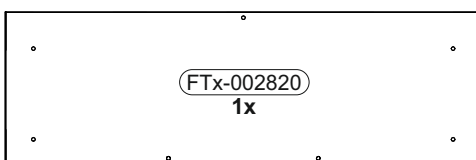

1007 x 328

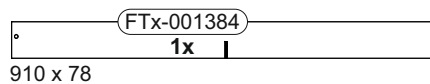



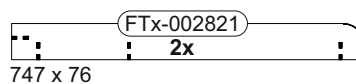

910 x 78





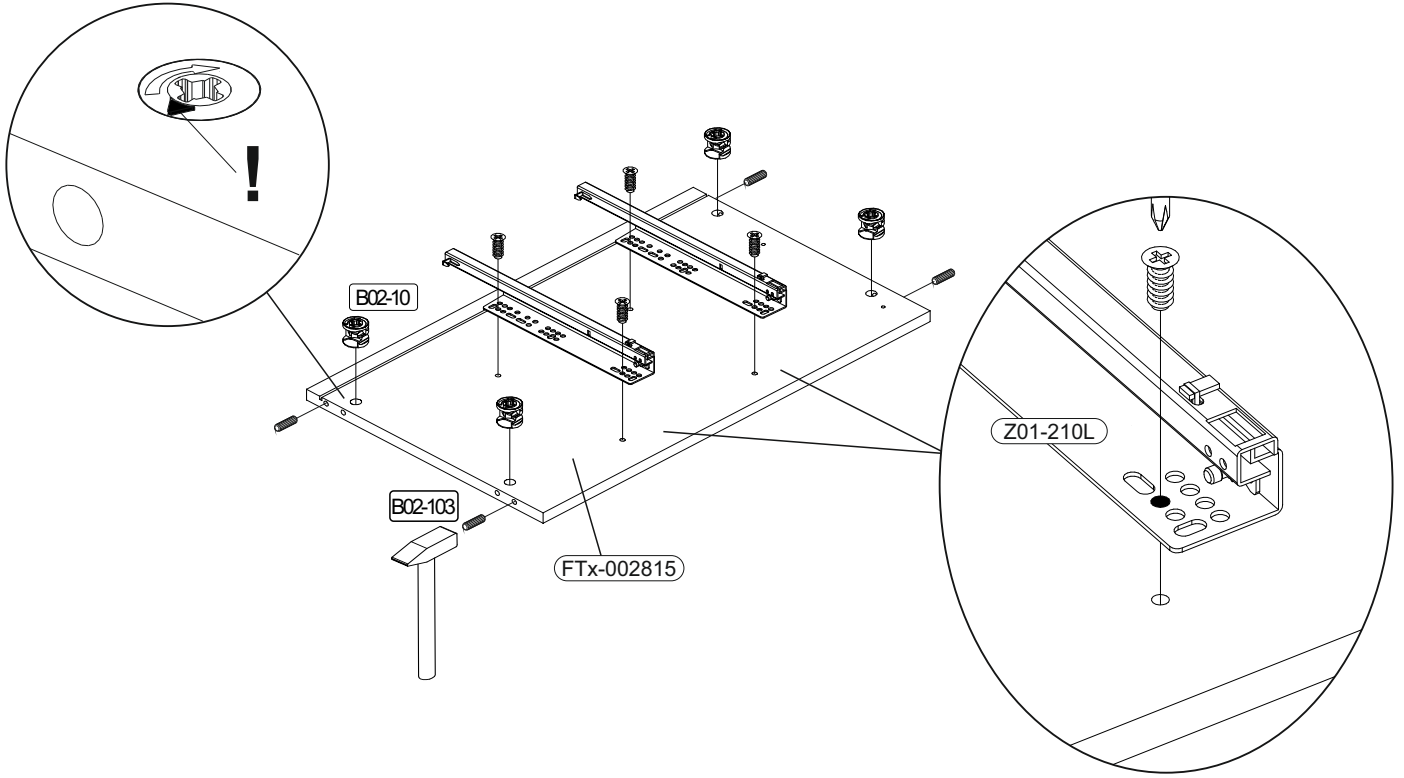

747 x 76

1

 +		B02-10		B01-200		B02-103	
		4x	ø15x12mm	4x	6,3x13	4x	8x30





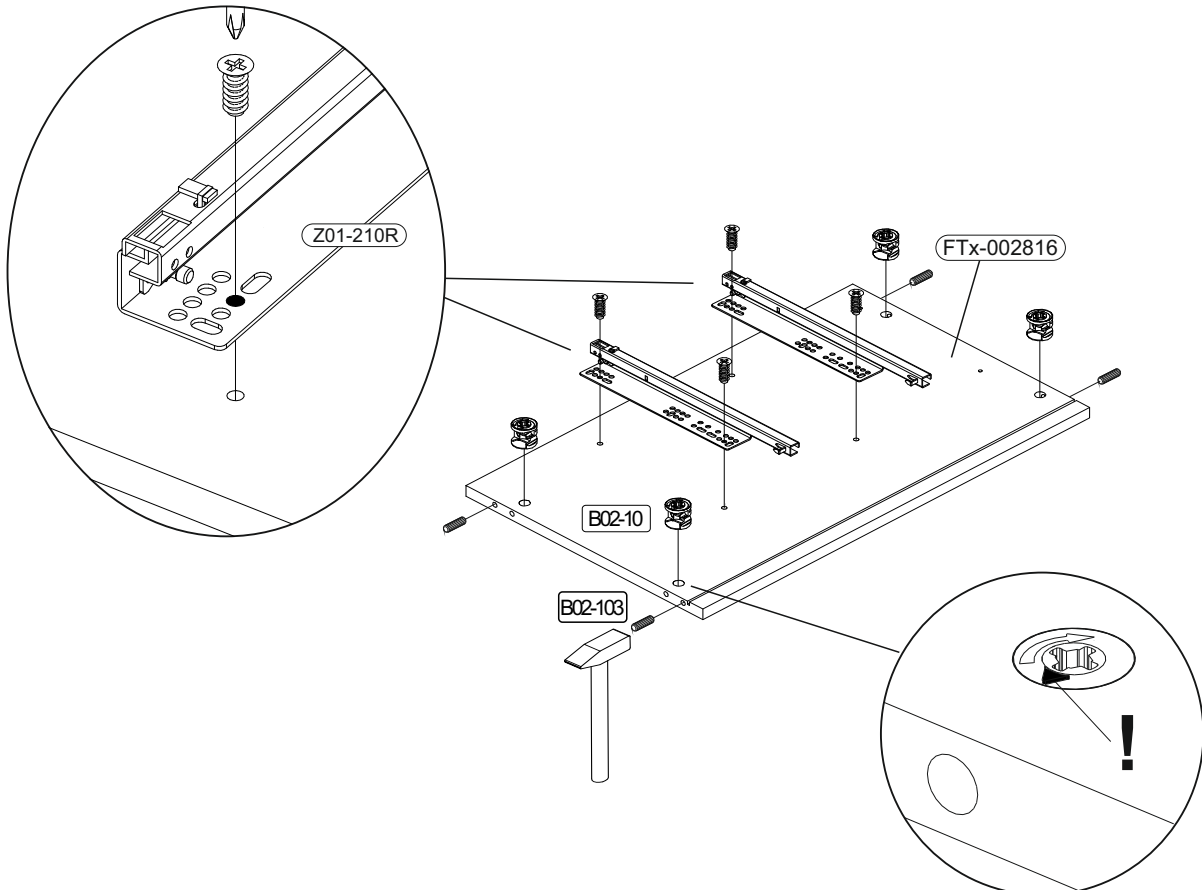

2

 +		B02-10		B01-200		B02-103	
		4x	ø15x12mm	4x	6,3x13	4x	8x30



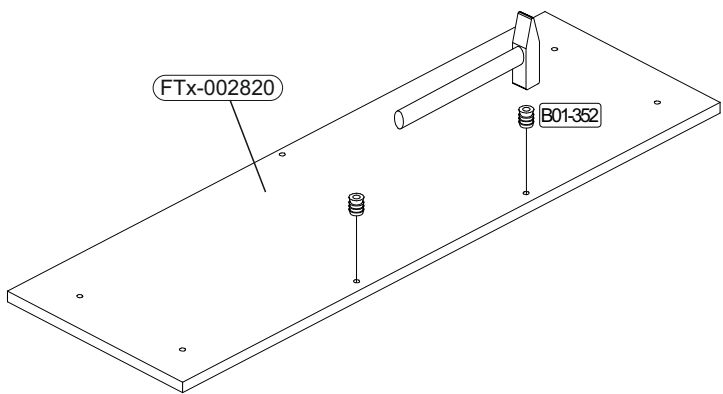
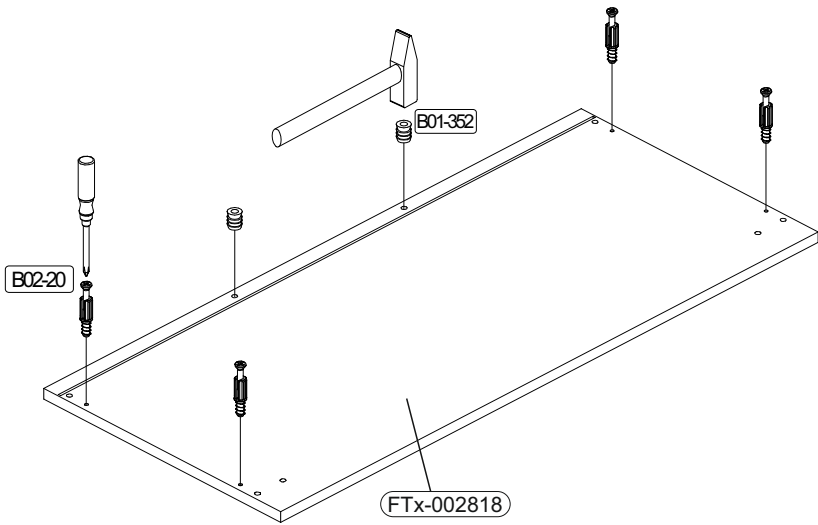

3

		B01-352		B02-20	
		4x		M4	



4

	B02-10	
	6x	

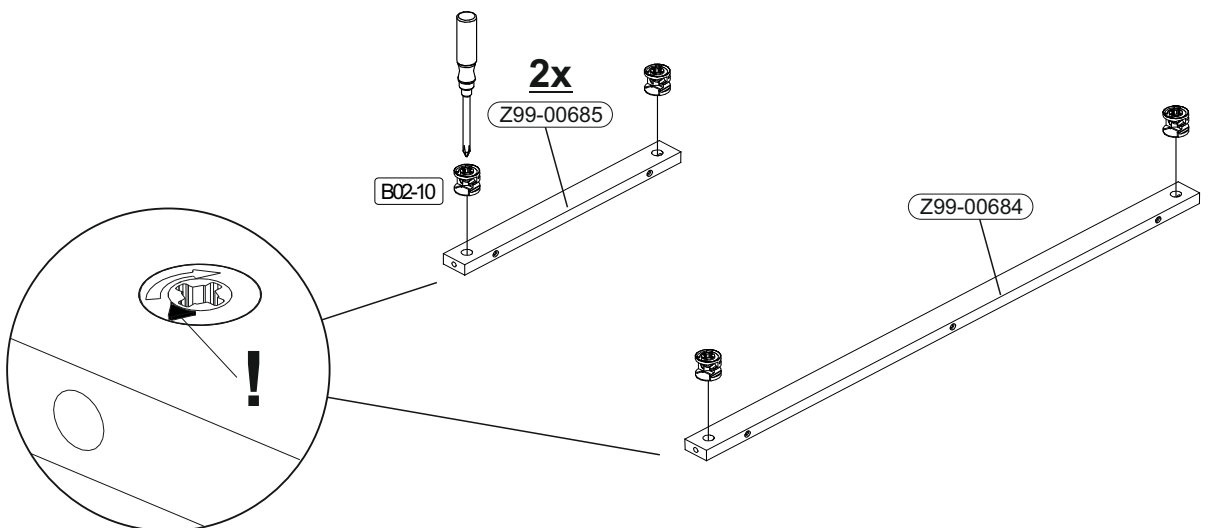

**5**

	<b>B01-10</b>		<b>B02-20</b>		<b>B01-174</b>	
	<b>4x</b>	<b>6,3x50</b>	<b>10x</b>		<b>7x</b>	<b>4,5x50</b>

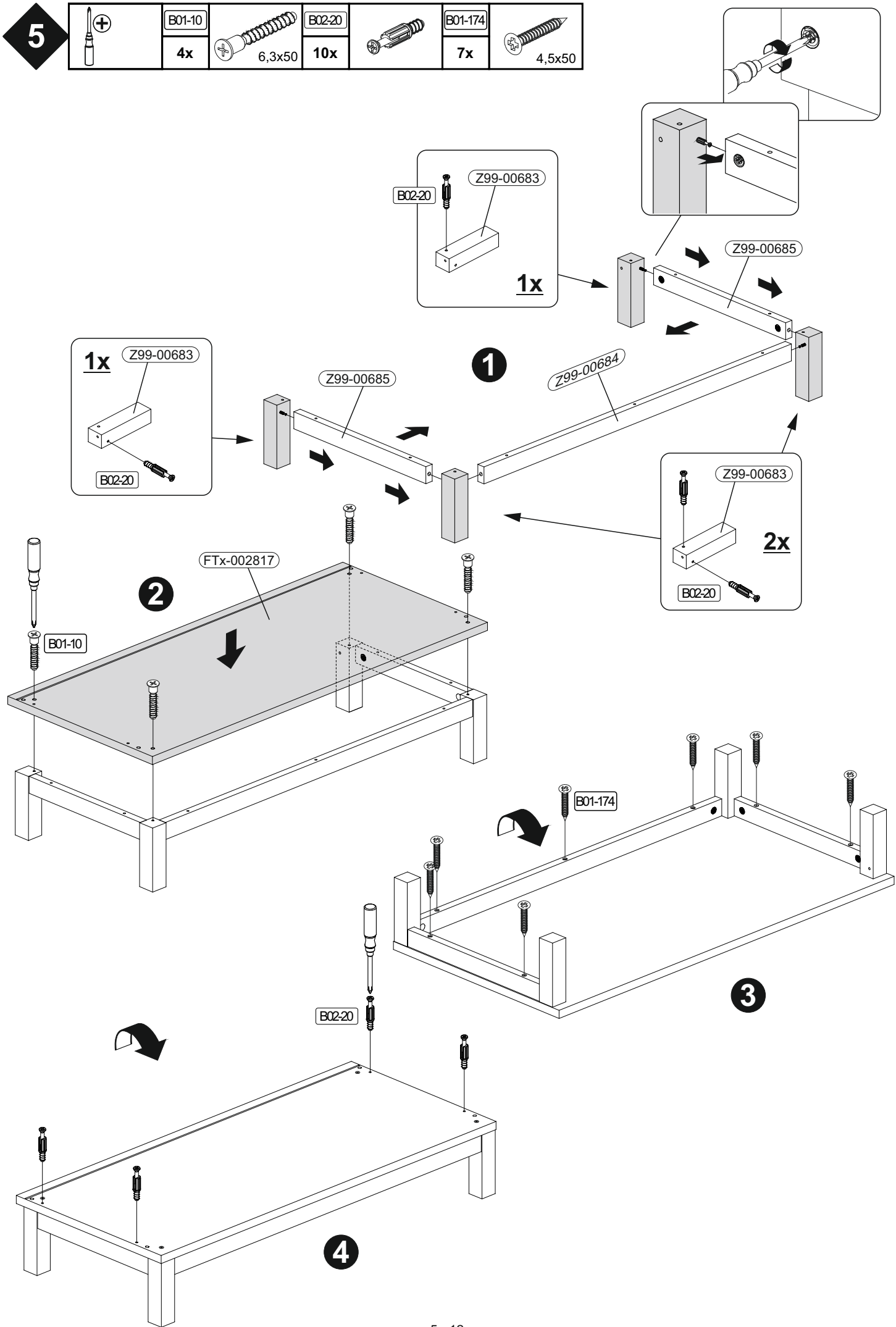

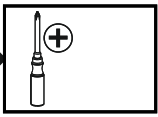
**6** 

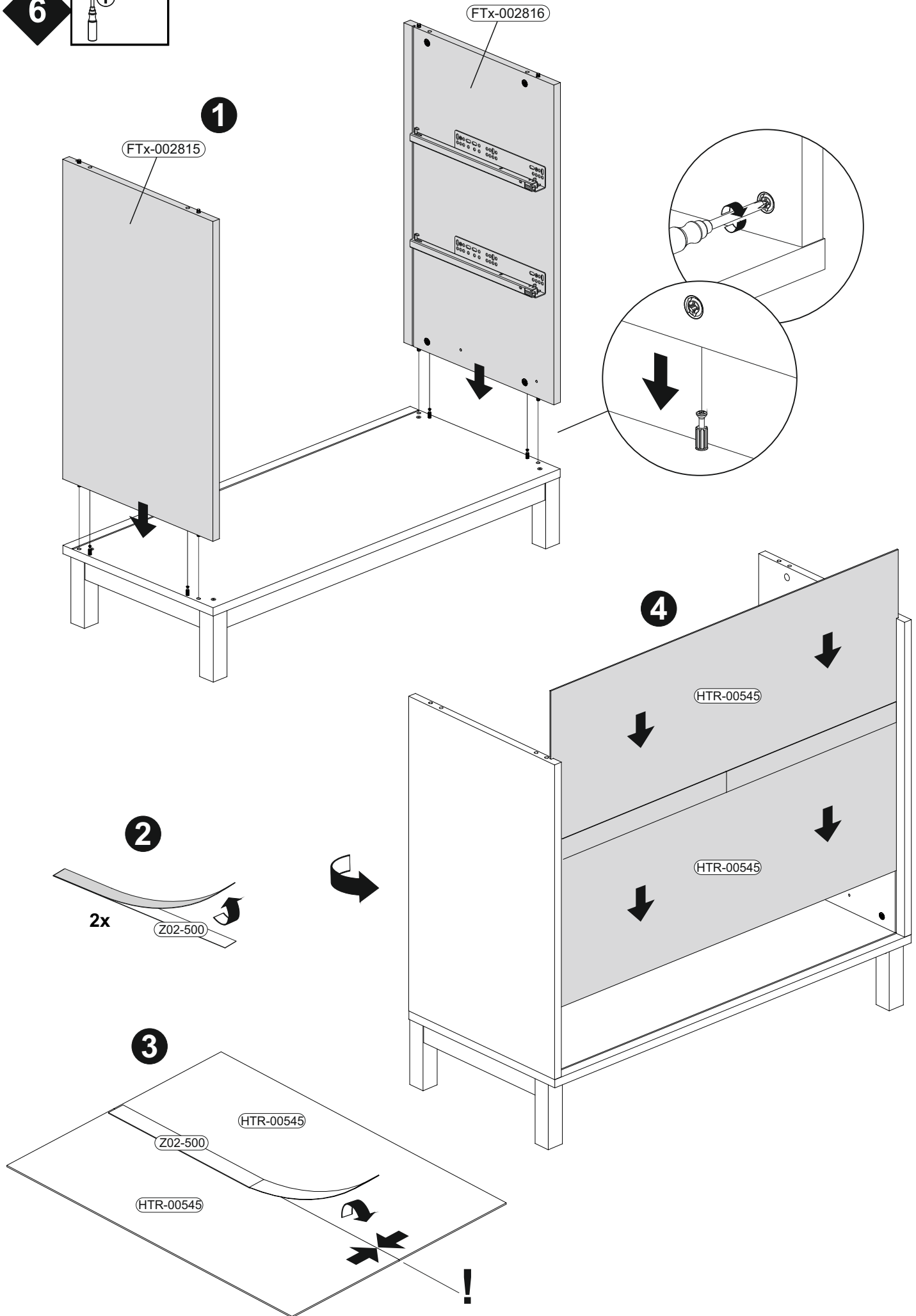

7

	B05-185		B01-90	
	4x		4x	3,5x20

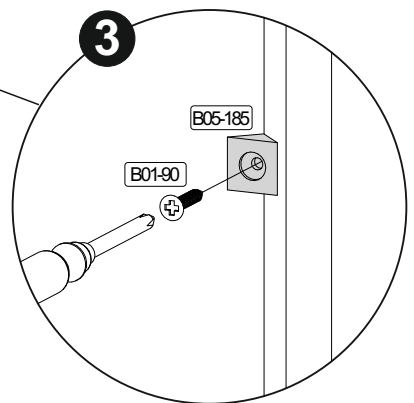
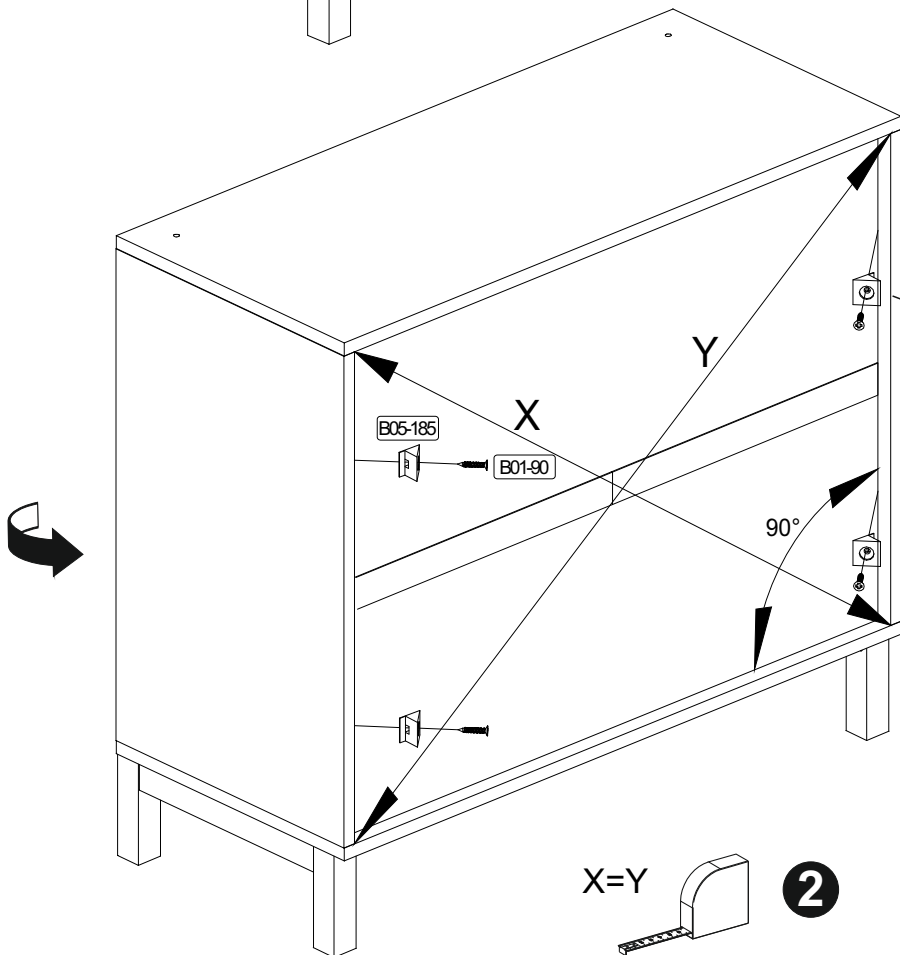
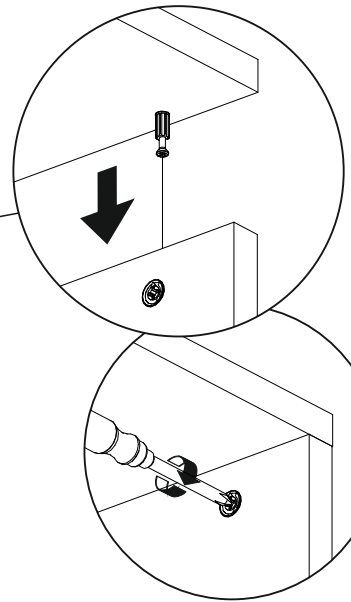
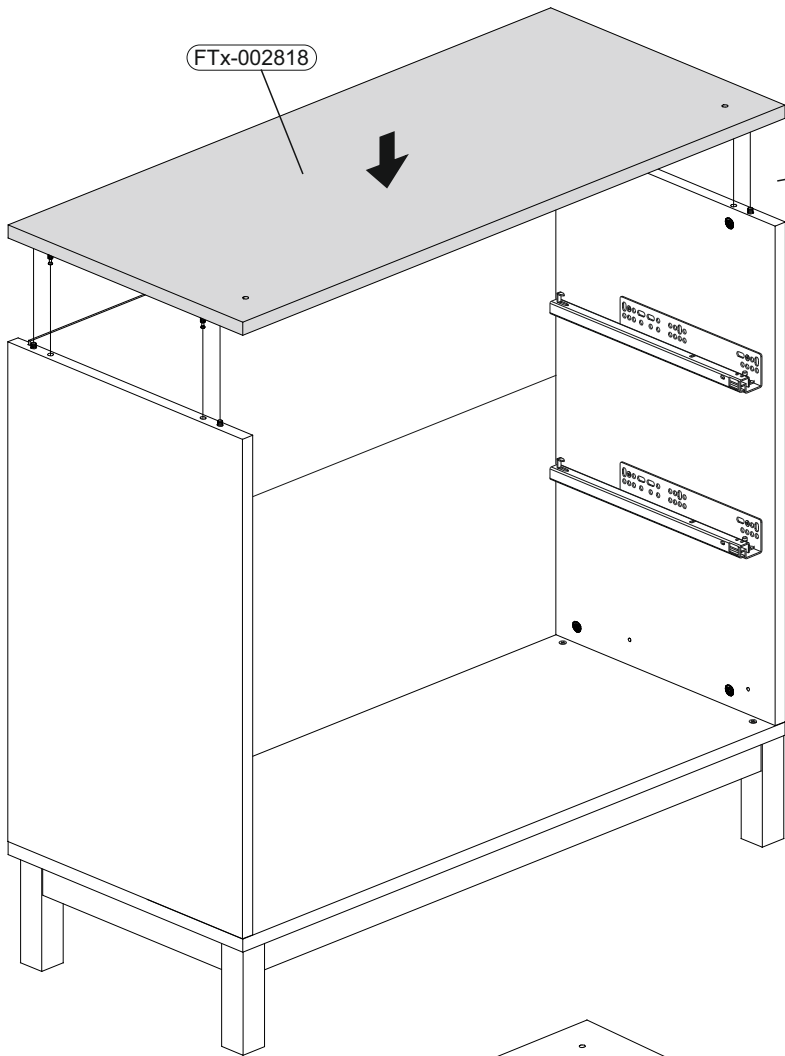

8

	9x	6,3x50	4x	2x	45x12

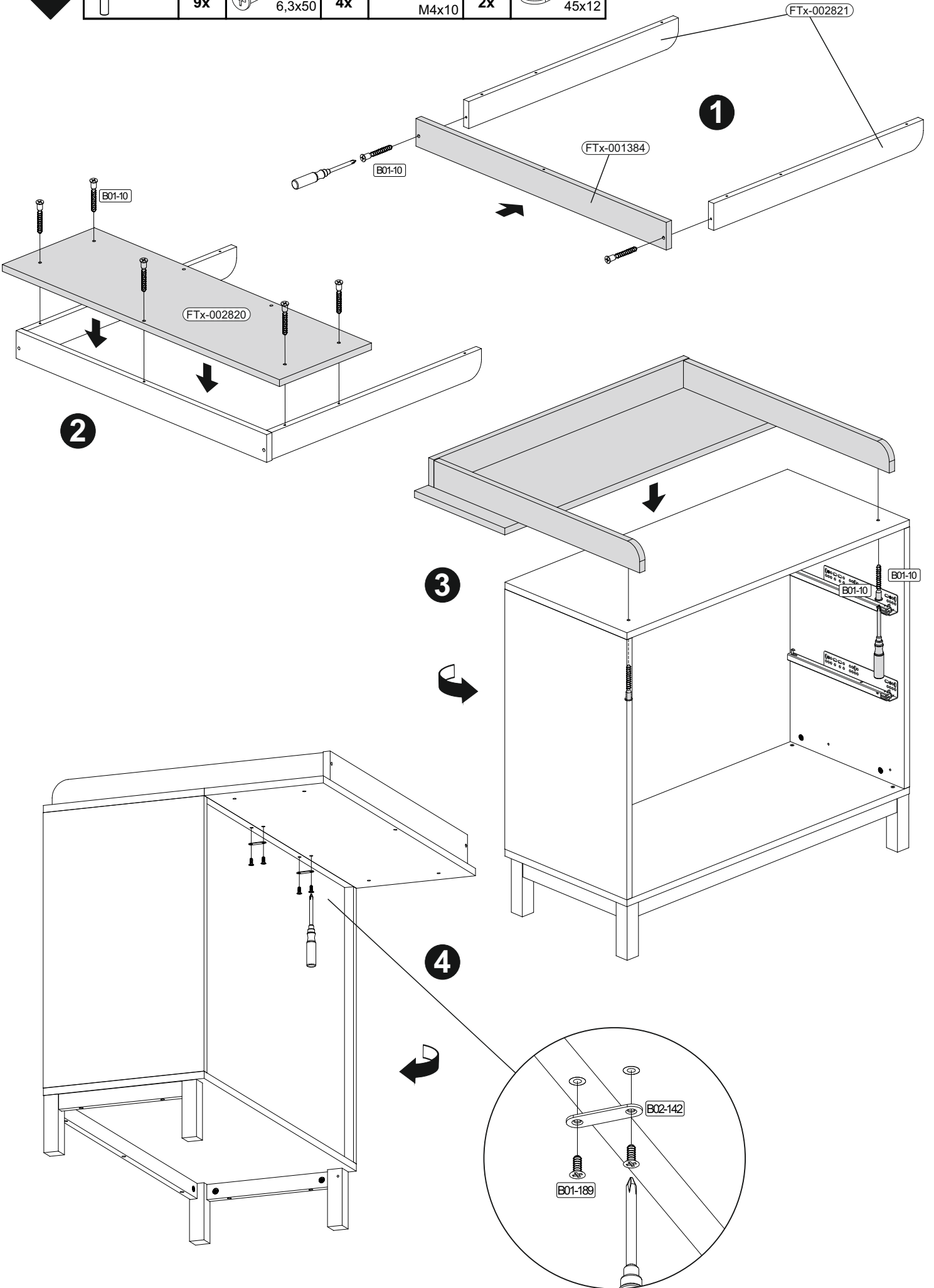

9

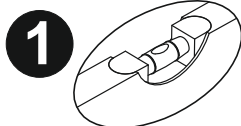
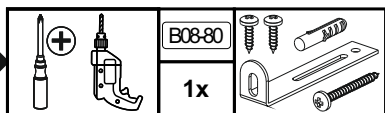

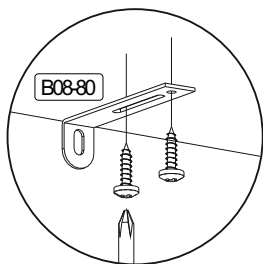

2

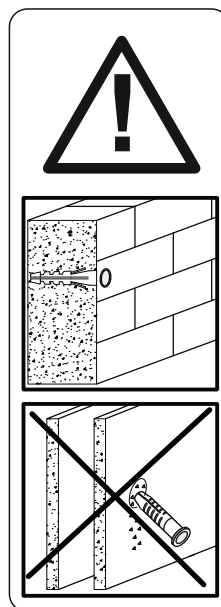
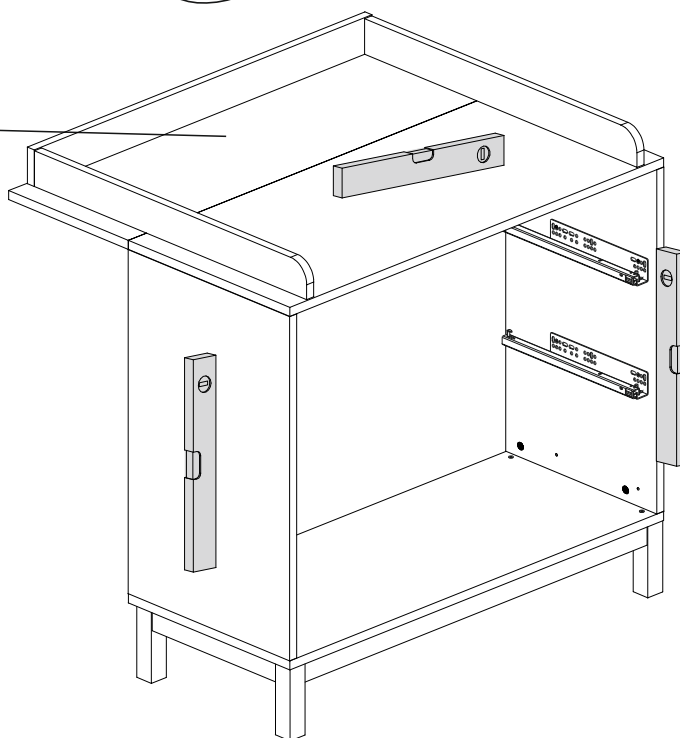
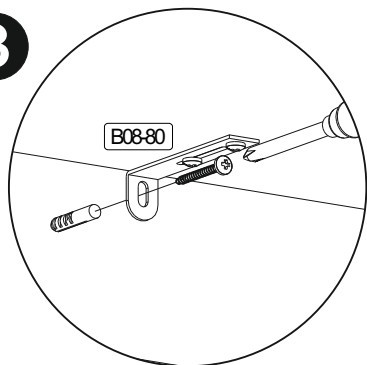

3



 <b>Achtung • Attention • Attenzione • Opgelet • Uwaga • Pozor • Figelem • Atenție • Dikkat • Внимание • Fara • Vaara • Fare • Peligro</b> 	
<b>(D)</b>	Wandbefestigung dient als Kippschutz - unbedingt anbringen! Bei einigen Wandtypen kann ein Spezialdübel erforderlich sein!
<b>(GB)</b>	The wall fastening serves to prevent tipping - be absolutely sure to mount it! For certain wall types, a special wall plug may be necessary!
<b>(FR)</b>	La fixation murale sert de protection contre le basculement – à installer impérativement ! Pour certains types de murs il faut des chevilles spéciales !
<b>(TR)</b>	Duvardaki sabitleme, devrilmeye karşı bir emniyet tedbiridir ve mutlaka monte edilmelidir! Bazı duvar tiplerinde bunun için özel bir dübel gerekli olabilir!
<b>(IT)</b>	Il fissaggio alla parete serve da protezione anti-ribaltamento – attaccarla assolutamente! Per alcune strutture di parete può essere necessario un tassello speciale!
<b>(NL)</b>	Bevestiging aan de muur dient als kantelbescherming – zeker en vast bevestigen! Bij enkele muurtypes is een speciale plug misschien vereist!
<b>(RU)</b>	Обязательно установите крепление на стене во избежание опрокидывания! Для некоторых типов стен может потребоваться специальный дюбель!
<b>(CZ)</b>	Montáž na stěnu slouží jako ochrana proti převrnutí – bezpodmínečně umístěte! U některých typů stěn může být zapotřebí speciální hmoždinka!
<b>(HU)</b>	A termék a falhoz kel rögzíténi, különben az felborulhat! Egyes faltípusoknál speciális tiplit kell használni!
<b>(RO)</b>	Sistemul de fixare la perete servește ca protecție la răsturnare - de montat obligatoriu! Pentru unele tipuri de pereți este posibil să fie necesar un diblu special!
<b>(PL)</b>	Mocowanie do ściany jest jednocześnie zabezpieczeniem przed przewróceniem – koniecznie zamontować! Do niektórych rodzajów ścian koniecznie zastosować specjalne kołki mocujące.
<b>(SWE)</b>	Väggmontering fungerar som anti-lutnings skydd - det är viktigt att fästa det! En speciell plugg kan behövas för vissa väggtyper!
<b>(FIN)</b>	Seinäkiinnitys toimii kaatumista estävänä suojana - se on ehdottomasti kiinnitettävä! Joihinkin seinätyypeihin voidaan tarvita erityistappi!
<b>(NOR)</b>	Veggmontering fungerer som anti-vippebeskyttelse - det er viktig å feste det! En spesiell dyvel kan være nødvendig for noen veggtyper!
<b>(DAN)</b>	Vægmontering fungerer som anti-vip beskyttelse - det er vigtigt at fastgøre det! En speciel dyvel kan være påkrævet til nogle vægtyper!
<b>(SK)</b>	Upevnenie na stenu slúži ako ochrana proti prevráteniu – bezpodmienečne použite! Pre niektoré druhy stien môže byť potrebná špeciálna hmoždinka!
<b>(ES)</b>	El montaje en la pared sirve como protección antivuelco: ¡es imprescindible fijarlo! ¡Es posible que se requiera una espiga especial para algunos tipos de paredes!

**10**

		B02-20		B02-10		B02-103		B01-30		B01-122	
		12x		12x	ø15x12mm	24x	8x30	30x	3x16	6x	4,0x13

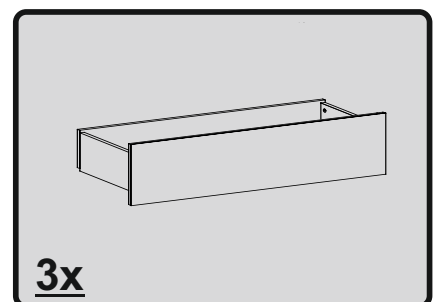
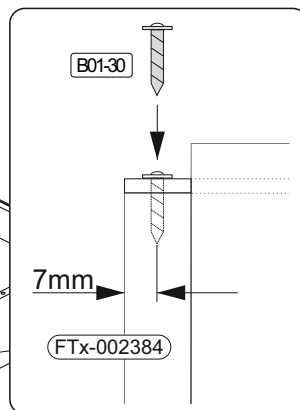
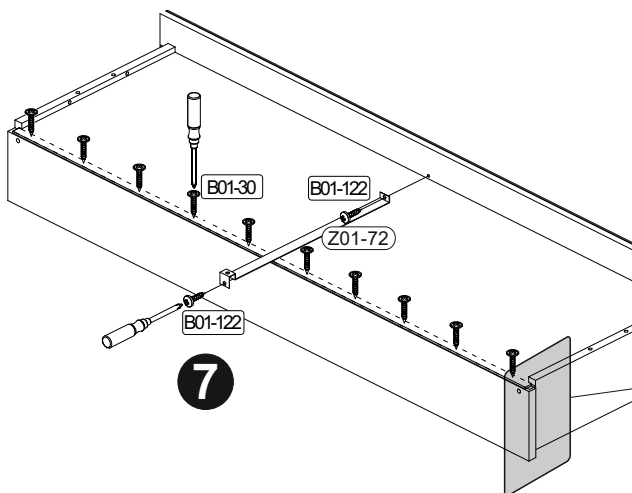
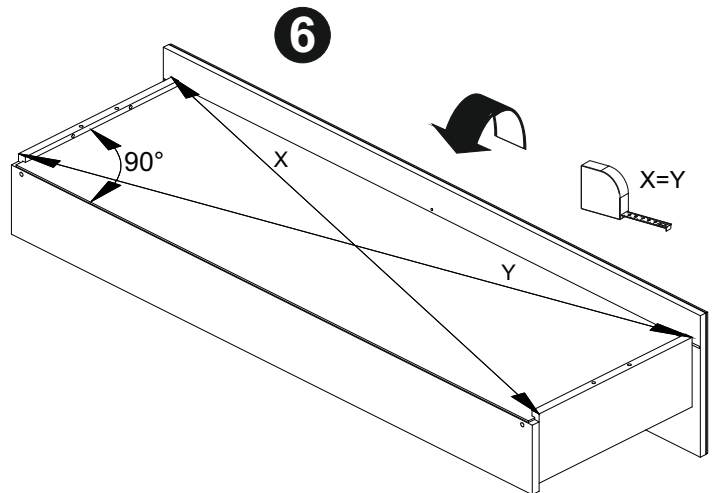
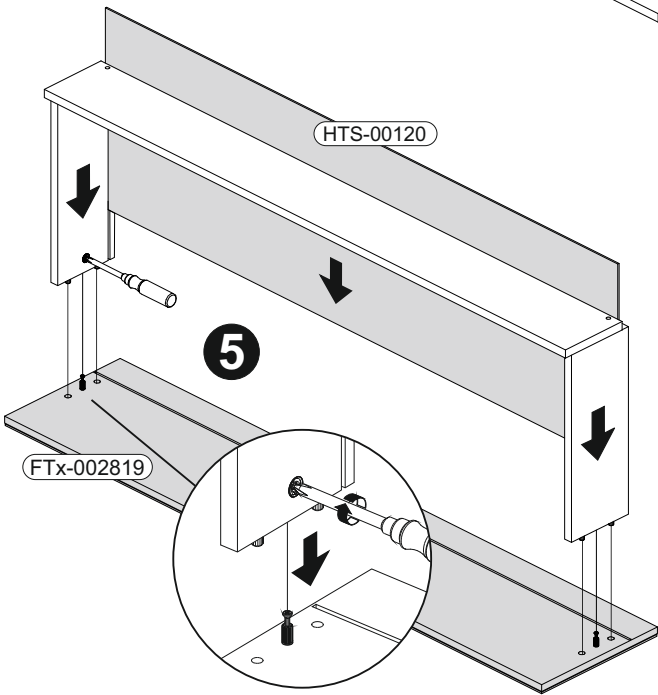
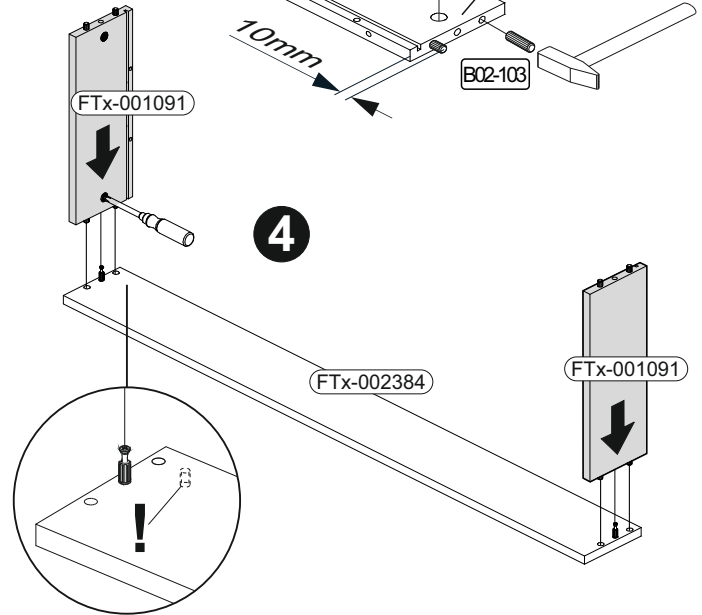
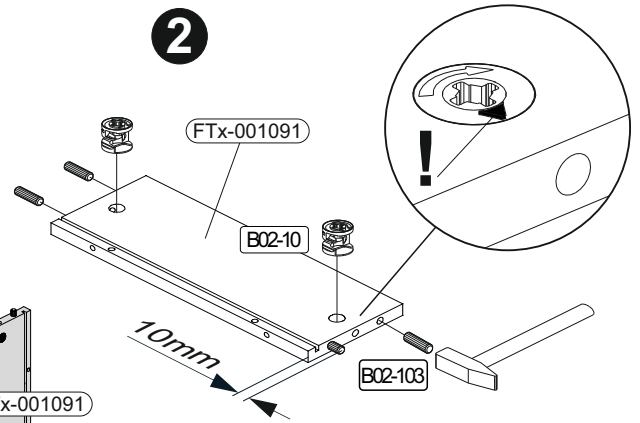
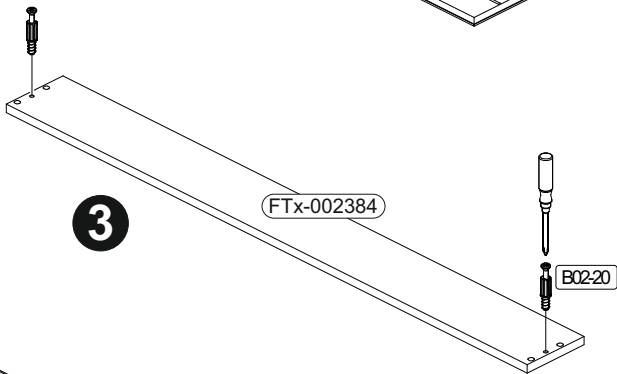
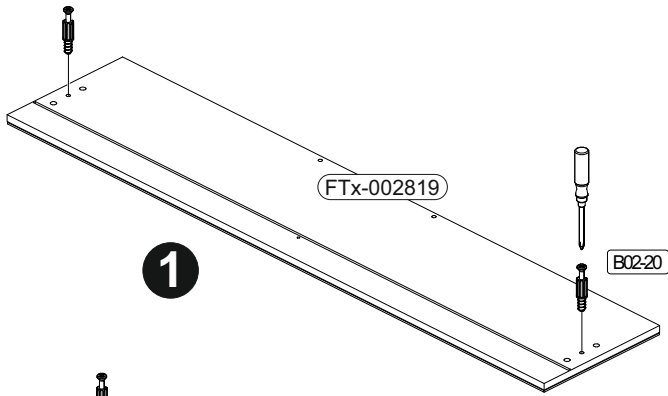

11

12x	ø20mm	10x	6,3x13	3x
				300mm

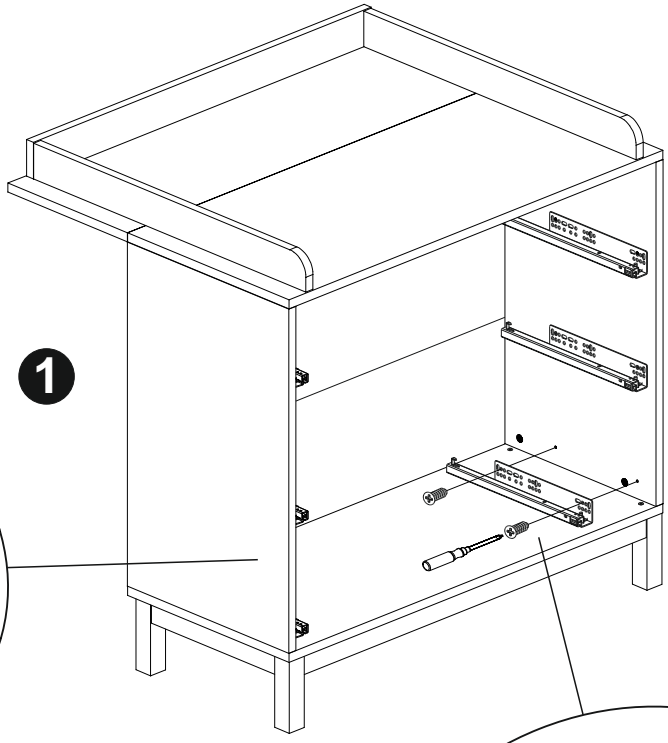

1

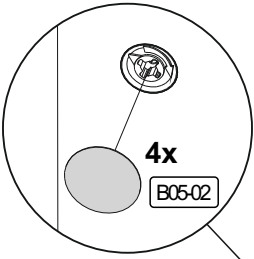
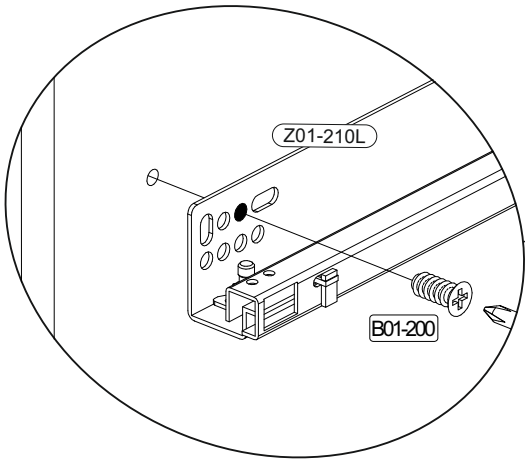

4x  
B05-02

2

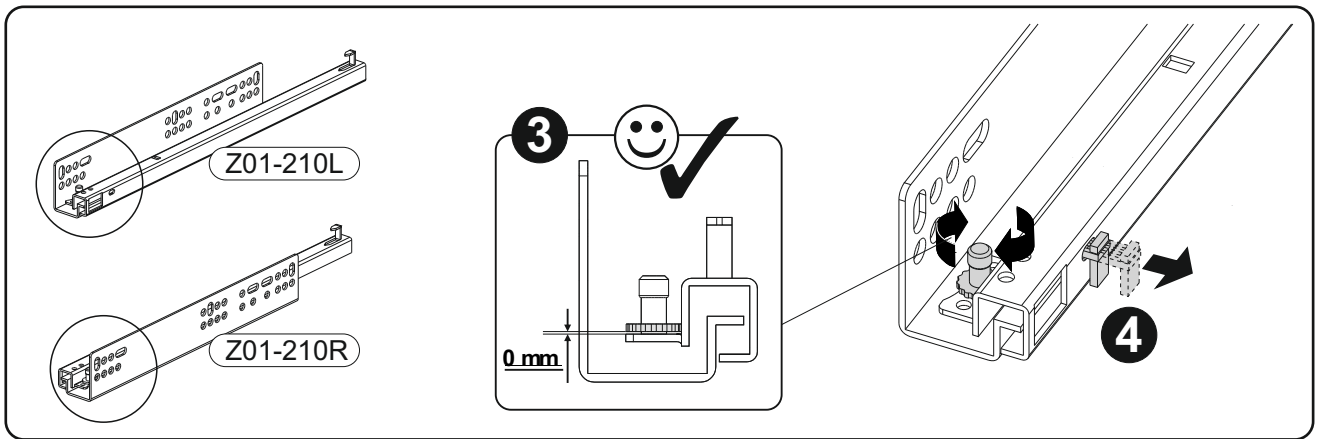
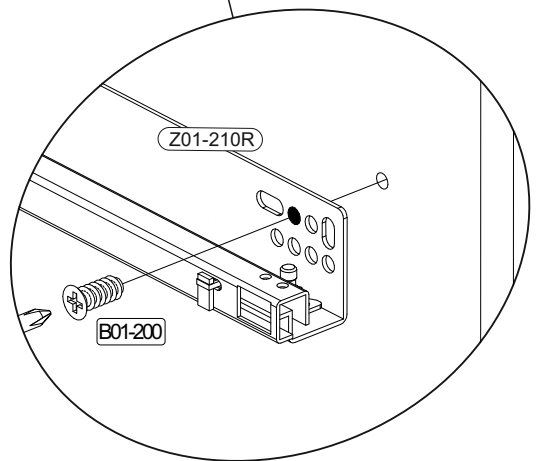
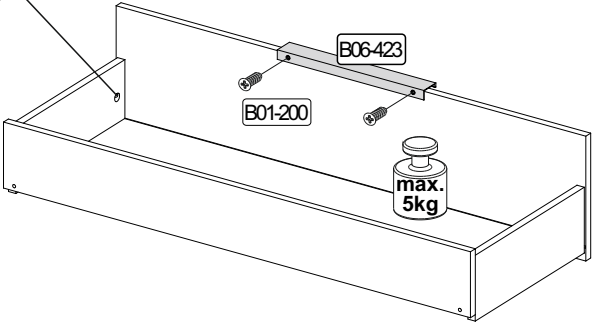

3

4

12

	B05-01	
	2x	ø14mm

