

Dieter Knoll Collection

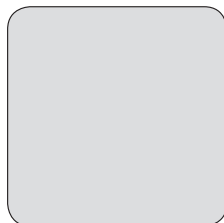
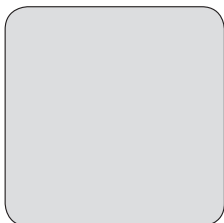
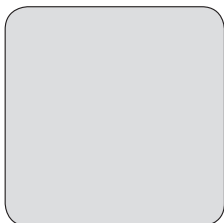
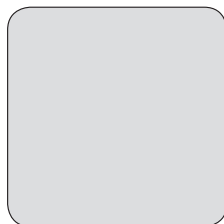
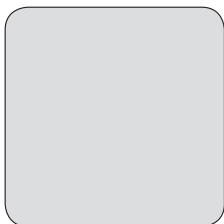
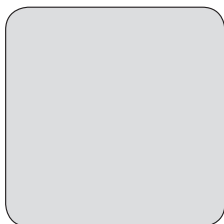
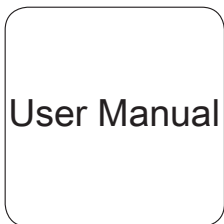

CONTENTS

Safety information	2	Automatic programmes	18
Safety instructions	3	Using the accessories	19
Installation	6	Additional functions	22
Product description	8	Hints and tips	24
Control panel	8	Care and cleaning	40
Before first use	10	Troubleshooting	44
Daily use	10	Energy efficiency	46
Clock functions	17		

Subject to change without notice.

SAFETY INFORMATION

Before the installation and use of the appliance, carefully read the supplied instructions. The manufacturer is not responsible for any injuries or damage that are the result of incorrect installation or usage. Always keep the instructions in a safe and accessible location for future reference.

Children and vulnerable people safety

- This appliance can be used by children aged from 8 years and above and persons with reduced physical, sensory or mental capabilities or lack of experience and knowledge if they have been given supervision or instruction concerning the use of the appliance in a safe way and understand the hazards involved.
- Children between 3 and 8 years of age and persons with very extensive and complex disabilities shall be kept away from the appliance unless continuously supervised.
- Children of less than 3 years of age should be kept away from the appliance unless continuously supervised.
- Do not let children play with the appliance.
- Keep all packaging away from children and dispose of it appropriately.
- Keep children and pets away from the appliance when it operates or when it cools down. Accessible parts may become hot during use.
- If the appliance has a child safety device, it should be activated.

- Children shall not carry out cleaning and user maintenance of the appliance without supervision.

General Safety

- Only a qualified person must install this appliance and replace the cable.
- **WARNING:** The appliance and its accessible parts become hot during use. Care should be taken to avoid touching heating elements.
- Always use oven gloves to remove or put in accessories or ovenware.
- Before carrying out any maintenance, disconnect the appliance from the power supply.
- **WARNING:** Ensure that the appliance is switched off before replacing the lamp to avoid the possibility of electric shock.
- Do not use the appliance before installing it in the built-in structure.
- Do not use a steam cleaner to clean the appliance.
- Do not use harsh abrasive cleaners or sharp metal scrapers to clean the glass door since they can scratch the surface, which may result in shattering of the glass.
- If the mains power supply cable is damaged, it must be replaced by the manufacturer, its Authorised Service Centre or similarly qualified persons to avoid an electrical hazard.
- To remove the shelf supports first pull the front of the shelf support and then the rear end away from the side walls. Install the shelf supports in the opposite sequence.

SAFETY INSTRUCTIONS

Installation



WARNING! Only a qualified person must install this appliance.

- Remove all the packaging.
- Do not install or use a damaged appliance.
- Follow the installation instructions supplied with the appliance.
- Always take care when moving the appliance as it is heavy. Always use safety gloves and enclosed footwear.
- Do not pull the appliance by the handle.

- Keep the minimum distance from other appliances and units.
- Install the appliance in a safe and suitable place that meets installation requirements.
- The appliance is equipped with an electric cooling system. It must be operated with the electric power supply.

Cabinet minimum height (Cabinet under the worktop minimum height)	590 (600) mm
Cabinet width	560 mm
Cabinet depth	550 (550) mm
Height of the front of the appliance	594 mm
Height of the back of the appliance	576 mm
Width of the front of the appliance	595 mm
Width of the back of the appliance	559 mm
Depth of the appliance	569 mm
Built in depth of the appliance	548 mm
Depth with open door	1022 mm
Ventilation opening minimum size. Opening placed on the bottom rear side	560x20 mm
Mains supply cable length. Cable is placed in the right corner of the back side	1500 mm
Mounting screws	4x25 mm

- All electrical connections should be made by a qualified electrician.
- The appliance must be earthed.
- Make sure that the parameters on the rating plate are compatible with the electrical ratings of the mains power supply.
- Always use a correctly installed shockproof socket.
- Do not use multi-plug adapters and extension cables.
- Make sure not to cause damage to the mains plug and to the mains cable. Should the mains cable need to be replaced, this must be carried out by our Authorised Service Centre.
- Do not let mains cables touch or come near the appliance door or the niche below the appliance, especially when it operates or the door is hot.
- The shock protection of live and insulated parts must be fastened in such a way that it cannot be removed without tools.
- Connect the mains plug to the mains socket only at the end of the installation. Make sure that there is access to the mains plug after the installation.
- If the mains socket is loose, do not connect the mains plug.
- Do not pull the mains cable to disconnect the appliance. Always pull the mains plug.
- Use only correct isolation devices: line protecting cut-outs, fuses (screw type fuses removed from the holder), earth leakage trips and contactors.
- The electrical installation must have an isolation device which lets you disconnect the appliance from the mains at all poles. The isolation device must have a contact opening width of minimum 3 mm.
- This appliance is supplied with a main plug and a main cable.

Electrical connection



WARNING! Risk of fire and electric shock.

Cable types applicable for installation or replacement for Europe:

H07 RN-F, H05 RN-F, H05 RRF, H05 VV-F, H05 V2V2-F (T90), H05 BB-F

For the section of the cable refer to the total power on the rating plate. You can also refer to the table:

Total power (W)	Section of the cable (mm ²)
maximum 1380	3 x 0.75
maximum 2300	3 x 1
maximum 3680	3 x 1.5

The earth cord (green / yellow cable) must be 2 cm longer than phase and neutral cables (blue and brown cables).

Use



WARNING! Risk of injury, burns and electric shock or explosion.

- This appliance is for household use only.
- Do not change the specification of this appliance.
- Make sure that the ventilation openings are not blocked.
- Do not let the appliance stay unattended during operation.
- Deactivate the appliance after each use.
- Be careful when you open the appliance door while the appliance is in operation. Hot air can release.
- Do not operate the appliance with wet hands or when it has contact with water.
- Do not apply pressure on the open door.
- Do not use the appliance as a work surface or as a storage surface.
- Open the appliance door carefully. The use of ingredients with alcohol can cause a mixture of alcohol and air.

- Do not let sparks or open flames to come in contact with the appliance when you open the door.
- Do not put flammable products or items that are wet with flammable products in, near or on the appliance.



WARNING! Risk of damage to the appliance.

- To prevent damage or discoloration to the enamel:
 - do not put ovenware or other objects in the appliance directly on the bottom.
 - do not put aluminium foil directly on the bottom of cavity of the appliance.
 - do not put water directly into the hot appliance.
 - do not keep moist dishes and food in the appliance after you finish the cooking.
 - be careful when you remove or install the accessories.
- Discoloration of the enamel or stainless steel has no effect on the performance of the appliance.
- Use a deep pan for moist cakes. Fruit juices cause stains that can be permanent.
- This appliance is for cooking purposes only. It must not be used for other purposes, for example room heating.
- Always cook with the oven door closed.
- If the appliance is installed behind a furniture panel (e.g. a door) make sure the door is never closed when the appliance is in operation. Heat and moisture can build up behind a closed furniture panel and cause subsequent damage to the appliance, the housing unit or the floor. Do not close the furniture panel until the appliance has cooled down completely after use.

Care and cleaning



WARNING! Risk of injury, fire, or damage to the appliance.

- Before maintenance, deactivate the appliance and disconnect the mains plug from the mains socket.
- Make sure the appliance is cold. There is the risk that the glass panels can break.
- Replace immediately the door glass panels when they are damaged. Contact the Authorised Service Centre.
- Be careful when you remove the door from the appliance. The door is heavy!
- Clean regularly the appliance to prevent the deterioration of the surface material.
- Clean the appliance with a moist soft cloth. Only use neutral detergents. Do not use any abrasive products, abrasive cleaning pads, solvents or metal objects.
- If you use an oven spray, follow the safety instruction on it's packaging.
- Do not clean the catalytic enamel (if applicable) with any kind of detergent.

Steam Cooking



WARNING! Risk of burns and damage to the appliance.

- Released Steam can cause burns:
 - Do not open the appliance door during the steam cooking operation.
 - Open the appliance door with care after the steam cooking operation.

INSTALLATION



WARNING! Refer to Safety chapters.

Internal lighting



WARNING! Risk of electric shock.

- The type of light bulb or halogen lamp used for this appliance is for household appliances only. Do not use it for house lighting.
- Before replacing the lamp, disconnect the appliance from the power supply.
- Only use lamps with the same specifications.

Service

- To repair the appliance contact the Authorised Service Centre.
- Use original spare parts only.

Disposal



WARNING! Risk of injury or suffocation.

- Disconnect the appliance from the mains supply.
- Cut off the mains electrical cable close to the appliance and dispose of it.
- Remove the door catch to prevent children or pets from becoming trapped in the appliance.

Building In

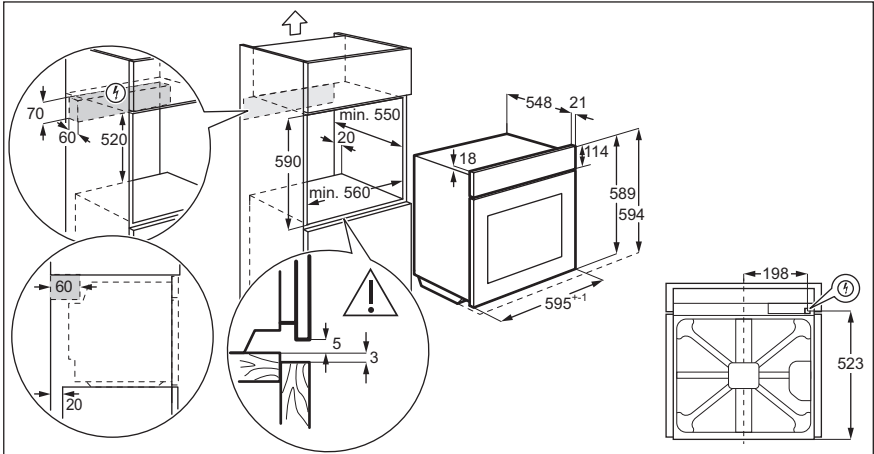
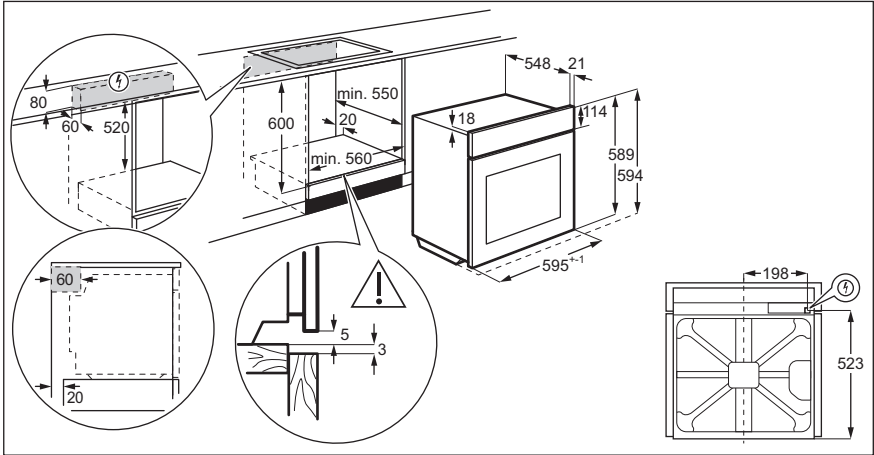

Securing the oven to the cabinet

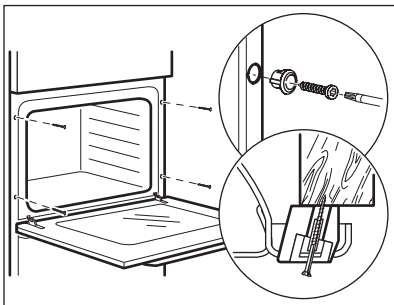

PRODUCT DESCRIPTION

General overview

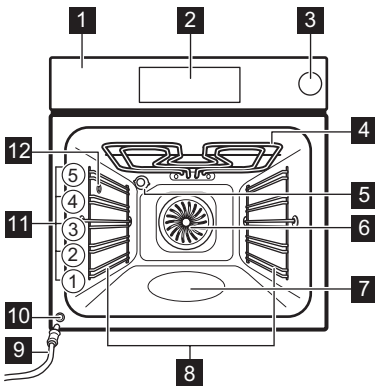

- 1** Control panel
- 2** Electronic programmer
- 3** Water drawer
- 4** Heating element
- 5** Lamp
- 6** Fan
- 7** Cavity embossment
- 8** Shelf support, removable
- 9** Draining pipe
- 10** Water outlet valve
- 11** Shelf positions
- 12** Steam inlet

Accessories

- **Wire shelf**
For cookware, cake tins, roasts.
- **Combi pan**

For cakes and biscuits. To bake and roast or as a pan to collect fat.





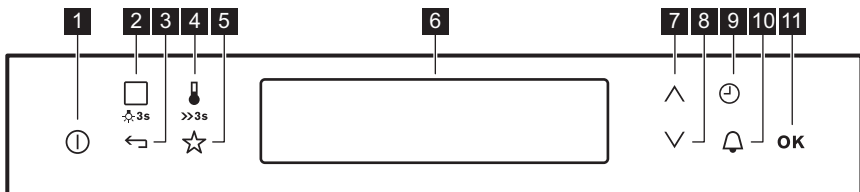

CONTROL PANEL

Electronic programmer



Use the sensor fields to operate the oven.

	Sensor field	Function	Comment
1		ON / OFF	To turn on and off the oven.
2		Heating Functions or Assisted Cooking	Press the sensor field once to choose a heating function or the menu: Assisted Cooking. Press the sensor field again to switch between the menus: Heating Functions, Assisted Cooking. To turn on or off the light, press the field for 3 seconds.



	Sensor field	Function	Comment
3		Back	To go back one level in the menu. To show the main menu, touch the field for 3 seconds.
4		Temperature selection/ Fast Heat Up	To set the temperature or show the current temperature in the oven. Press the field for 3 seconds to turn on or off the function: Fast Heat Up.
5		Favourites	To save and access your favourite programmes.
6	-	Display	Shows the current settings of the oven.
7		Up	To move up in the menu.
8		Down	To move down in the menu.
9		Time and additional functions	To set different functions. When a heating function operates, press the sensor field to set the timer or the functions: Function Lock, Favourites, Heat + Hold, Set + Go.
10		Minute Minder	To set the function: Minute Minder.
11	OK	OK	To confirm the selection or setting.

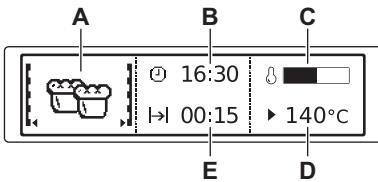







Display



- A. Heating function
- B. Time of day
- C. Heat-up indicator
- D. Temperature
- E. Duration time or end time of a function

Other indicators of the display:

Symbol	Function	
	Minute Minder	The function works.
	Time of day	The display shows the current time.
	Duration	The display shows the necessary time for cooking.

Symbol	Function	
	End Time	The display shows when the cooking time is complete.
	Temperature	The display shows the temperature.
	Time Indication	The display shows how long the heating function works. Press  and  at the same time to reset the time.
	Heat-up Indicator	The display shows the temperature in the oven.
	Fast Heat Up	The function is on. It decreases the heat up time.
	Weight Automatic	The display shows that the automatic weight system is on or that weight can be changed.
	Heat + Hold	The function is on.

BEFORE FIRST USE



WARNING! Refer to Safety chapters.

Initial Cleaning

Remove all accessories and removable shelf supports from the oven.

Refer to "Care and cleaning" chapter.

Clean the oven and the accessories before the first use.

Put the accessories and the removable shelf supports back to their initial position.



First Connection

When you connect the oven to the mains or after the power cut, you have to set the language, the display contrast, the display brightness and the time of the day.

DAILY USE





WARNING! Refer to Safety chapters.

1. Press  or  to set the value.
2. Press **OK** to confirm.

Preheating

Remove all accessories and preheat the oven before first use.

1. Set the function: Conventional Cooking  and the maximum temperature.
2. Let the oven operate for 1 hour.
3. Set the function: True Fan Cooking  and the maximum temperature.
4. Let the oven operate for 15 minutes. The oven can emit an odour and smoke during preheating. Make sure that the airflow in the room is sufficient.

Navigating the menus

1. Turn on the oven.

2. Press \checkmark or \wedge to select the menu option.
3. Press **OK** to move to the submenu or accept the setting.



At each point you can go back to the main menu with \leftarrow .





The menus in overview

Main menu



Symbol / Menu item	Application
 Heating Functions	Contains a list of heating functions.
 Recipes	Contains a list of automatic programmes.
 Favourites	Contains a list of favourite cooking programmes created by the user.
 Basic Settings	Used to set the appliance configuration.
 Specials	Contains a list of additional heating functions.
 Assisted Cooking	Contains recommended oven settings for a wide choice of dishes. Select a dish and start the cooking process. The temperature and time are only guidelines for a better result and can be adjusted. They depend on the recipes and the quality and quantity of the used ingredients.





Submenu for: Basic Settings





Symbol / Menu item	Description
 Set Time of Day	Sets the current time on the clock.
 Time Indication	When ON, the display shows the current time when you deactivate the appliance.
 Fast Heat Up	When ON, the function decreases the heat-up time.
 Set + Go	To set a function and activate it later with a press of any symbol on the control panel.
 Heat + Hold	Keeps the prepared food warm for 30 minutes after a cooking cycle finished.
 Time Extension	Activates and deactivates the time extension function.
 Display Contrast	Adjusts the display contrast by degrees.
 Display Brightness	Adjusts the display brightness by degrees.
 Set Language	Sets the language for the display.
 Buzzer Volume	Adjusts the volume of press-tones and signals by degrees.
 Key Tones	Activates and deactivates the tone of the touch fields. It is not possible to deactivate the tone of the ON / OFF touch field.

Symbol / Menu item	Description
 Alarm/Error Tones	Activates and deactivates the alarm tones.
 DEMO mode	Activation / deactivation code: 2468.
 Service	Shows the software version and configuration.
 Factory Settings	Resets all settings to factory settings.



Heating Functions







Heating function	Application
 True Fan Cooking	To bake on up to three shelf positions at the same time and to dry food. Set the temperature 20 - 40 °C lower than for the function: Conventional Cooking.
 True Fan + Steam	To steam dishes. Use this function to decrease the length of the cooking time and to preserve the vitamins and nutrients in the food. Select the function and set the temperature between 130 °C to 230 °C.
 Pizza Setting	To bake food on one shelf position for a more intensive browning and a crispy bottom. Set the temperature 20 - 40 °C lower than for the function: Conventional Cooking.

Heating function	Application
 Conventional Cooking	To bake and roast food on one shelf position.
 Slow Cooking	To prepare tender, succulent roasts.
 Bottom Heat	To bake cakes with crispy bottom and to preserve food.
 Moist Fan Baking	This function is designed to save energy during cooking. For the cooking instructions refer to "Hints and tips" chapter, Moist Fan Baking. The oven door should be closed during cooking so that the function is not interrupted and to ensure that the oven operates with the highest energy efficiency possible. When you use this function, the temperature in the cavity may differ from the set temperature. The residual heat is used. The heating power may be reduced. For general energy saving recommendations refer to "Energy Efficiency" chapter, Energy Saving. This function was used to comply with the energy efficiency class according to EN 60350-1. When you use this function the lamp automatically turns off after 30 seconds.

Heating function	Application
 Frozen Foods	To make convenience food (e.g. french fries, potato wedges or spring rolls) crispy.
 Grill	To grill flat food and to toast bread.
 Fast Grilling	To grill flat food in large quantities and to toast bread.
 Turbo Grilling	To roast larger meat joints or poultry with bones on one shelf position. To make gratins and to brown.
 Steam Regenerating	Food reheating with steam prevents surface drying. Heat is distributed in a gentle and even way, which allows to recover taste and aroma of food as just prepared. This function can be used to reheat food directly on a plate. You can reheat more than one plate at the same time, using different shelf positions.

Specials

Heating function	Application
 Bread Baking	To bake bread.
 Au Gratin	For dishes such as lasagna or potato gratin. To make gratins and to brown.

Heating function	Application
 Dough Proving	To rise the yeast dough before baking.
 Plate Warming	To preheat plates for serving.
 Preserving	To make vegetable preserves (e.g. pickles).
 Drying	To dry sliced fruit, vegetables and mushrooms.
 Keep Warm	To keep food warm.
 Defrost	To defrost food (vegetables and fruit). The defrosting time depends on the amount and size of the frozen food.

Assisted Cooking

Food Category: Fish / Seafood



Dish	
Fish	Fish, baked
	Fish fingers
	Fish fillet, frozen
	Whole small fish, grilled
Whole salmon	-

Food Category: Poultry

Dish	
Boned poultry	-

Dish	
Chicken	Chicken wings, fresh
	Chicken wings, frozen
	Chicken legs, fresh
	Chicken legs, frozen
	Chicken, 2 halves

Food Category: Meat

Dish	
Beef	Braised meat 
	Meatloaf
Roast beef	Rare
	Medium
	Well done
Pork	Spare ribs
	Pork knuckle, pre-cooked
	Pork joint
	Loin of pork
	Pork neck
	Pork shoulder
	Veal knuckle
Veal	Loin of veal
	Roast veal 
Lamb	Leg of lamb
	Saddle of lamb
	Lamb joint, medium

Dish	
Game	Hare <ul style="list-style-type: none"> • Leg of hare • Saddle of hare
	Venison <ul style="list-style-type: none"> • Haunch of venison • Saddle of venison
	Roast game 

Food Category: Oven Dishes

Dish	
Lasagne / Canneloni, frozen	-
Vegetables au gratin	-
Sweet dishes	-

Food Category: Pizza / Quiche

Dish	
Pizza	Pizza, thin
	Pizza, extra topping
	Pizza, frozen
	Pizza American, frozen
	Pizza, chilled
	Pizza snacks, frozen
Baguettes au gratin	-
Tarte flambée	-
Swiss Tarte, savoury	-
Quiche lorraine	-
Savory flan	-

Food Category: Cake / Pastry

Dish	
Ring cake	-
Apple cake, covered	-
Sponge cake	-
Apple pie	-
Cheese cake, tin	-
Brioche	-
Madeira cake	-
Tarte	-
Swiss Tarte, sweet	-
Almond cake	-
Muffins	-
Pastry	-
Pastry strips	-
Cream puffs	-
Puff pastry	-
Eclairs	-
Macaroons	-
Short pastry biscuits	-
Christmas stollen	-
Apple strudel, frozen	-
Cake on tray	Sponge dough
	Yeast dough
Cheese cake, tray	-
Brownies	-
Swiss roll	-
Yeast cake	-
Crumble cake	-
Sugar cake	-

Dish	
Flan base	Short pastry flan base
	Sponge mixture flan base
Fruit flan	Short pastry fruit flan
	Sponge mixture fruit flan
	Yeast dough

Food Category: Bread / Rolls

Dish	
Rolls	Rolls, frozen
Ciabatta	-
Bread	Bread crown
	Yeast plait
	Unleavened bread

Food Category: Side dishes

Dish	
French fries, thin	-
French fries, thick	-
French fries, frozen	-
Croquettes	-
Wedges	-
Hash browns	-



When it is necessary to change the weight use \wedge or \vee to set the new value.

Setting a heating function

1. Turn on the oven.
2. Select the menu: Heating Functions.
3. Press **OK** to confirm.
4. Select a heating function.
5. Press **OK** to confirm.

6. Set the temperature.
7. Press **OK** to confirm.

Setting a steam function

The water drawer cover is in the control panel.



WARNING! Use only cold tap water. Do not use filtered (demineralised) or distilled water. Do not use other liquids. Do not put flammable or alcoholic liquids into the water drawer.

1. Press the cover of the water drawer to open it.
2. Fill the water drawer with 900 ml of water.
The water supply is sufficient for approximately 55 - 60 minutes.
3. Push the water drawer to its initial position.
4. Turn on the oven.
5. Set a steam heating function and the temperature.
6. If necessary, set the function: Duration \rightarrow | or: End Time \rightarrow |.



When the steam generator is empty, the signal sounds.

The signal sounds at the end of the cooking time.

7. Turn off the oven.
8. Empty the water tank after the steam cooking is completed. Refer to the cleaning function: Tank Emptying.



CAUTION! The oven is hot. There is a risk of burns. Be careful when you empty the water tank.

9. After steam cooking steam can condensate on the bottom of the cavity. Always dry the bottom of the cavity when the oven is cool.

Let the oven dry fully with the door open.



WARNING! Wait a minimum of 60 minutes after each use of the steam cooking in order to prevent hot water from exiting the water outlet valve.

Tank Empty indicator

The display shows: Water required and a signal sounds when the tank is empty and must be refilled.

For more information refer to "Daily use" chapter, Setting a steam function.

Tank Full indicator

When the display shows: Water tank full, you can use the steam cooking.

A signal sounds when the tank is full.



If you put too much water into the tank, the safety outlet moves the excess water to the bottom of the oven. Remove the water with a sponge or cloth.

Emptying the water tank



CAUTION! Make sure that the oven is cold before you start to empty the water tank.

Empty the water tank after each steam cooking.

1. Prepare the draining pipe (C), included in the same package with the user manual. Put the connector (B) onto one of the ends of the draining pipe.

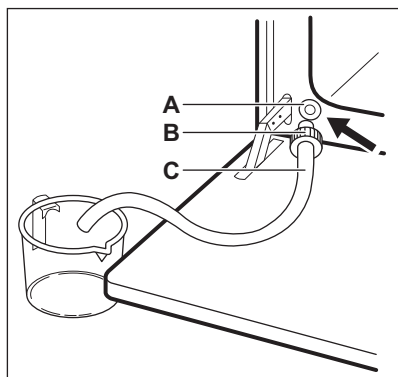

2. Put the second end of the draining pipe (C) into a container. Put it at a lower position than the outlet valve (A).
3. Open the oven door and put the connector (B) into the outlet valve (A).
4. Push the connector again and again when you empty the water tank.

i The tank can have some water when the display shows: Water required. Wait until the water flow from the water outlet valve stops.

5. Remove the connector from the valve when the water stops flowing.

i Do not use the drained water to fill the water tank again.

Heat-up indicator

When you turn on a heating function, the bar on the display comes on. The bar shows that the temperature increases. When temperature is reached the buzzer sounds 3 times and the bar flashes and then disappears.

Fast Heat Up

This function decreases the heat-up time.

i Do not put food in the oven when the Fast heat up function works.





To turn on the function, hold  for 3 seconds. The heat-up indicator alternates. This function is not available for some oven functions.



Residual heat

When you turn off the oven, the display shows the residual heat. You can use the heat to keep the food warm.

CLOCK FUNCTIONS

Clock functions table

Clock function	Application
 Minute Minder	To set a countdown (max. 2 h 30 min). This function has no effect on the operation of the oven. Use  to turn on the function. Press  or  to set the minutes and OK to start.

Clock function	Application
 Duration	To set how long the oven works (max. 23 h 59 min).
 End Time	To set the switch-off time for a heating function (max. 23 h 59 min).

If you set the time for a clock function, the time starts to count down after 5 seconds.





If you use the clock functions: Duration, End Time, the oven turns off the heating elements after 90 % of the set time. The oven uses the residual heat to continue the cooking process until the time ends (3 - 20 minutes).

Setting the clock functions



Before you use the functions: Duration, End Time, you must set a heating function and temperature first. The oven turns off automatically. You can use the functions: Duration and End Time at the same time if you want to automatically turn on and turn off the oven on a given time later.

1. Set a heating function.
 2. Press  again and again until the display shows the necessary clock function and the related symbol.
 3. Press  or  to set the necessary time.
 4. Press **OK** to confirm.
- When the time ends, a signal sounds. The oven turns off. The display shows a message.
5. Press any symbol to stop the signal.

Heat + Hold

Conditions for the function:

AUTOMATIC PROGRAMMES



WARNING! Refer to Safety chapters.

Recipes with Recipe Automatic

This oven has a set of recipes you can use. The recipes are fixed and you cannot change them.

1. Turn on the oven.

- The set temperature is more than 80 °C.
- The function: Duration is set.

The function: Heat + Hold keeps prepared food warm at 80 °C for 30 minutes. It turns on after the baking or roasting procedure ends.

You can turn on or turn off the function in the menu: Basic Settings.



1. Turn on the oven.
 2. Select the heating function.
 3. Set the temperature above 80 °C.
 4. Press  again and again until the display shows: Heat + Hold.
 5. Press **OK** to confirm.
- When the function ends, a signal sounds.

Time Extension

The function: Time Extension makes the heating function continue after the end of Duration.



Applicable to all heating functions with Duration or Weight Automatic.

1. When the cooking time ends, a signal sounds. Press any symbol. The display shows the message.
2. Press  to turn on or  to cancel.
3. Set the length of the function.
4. Press **OK**.

2. Select the menu: Recipes. Press **OK** to confirm.
3. Select the category and dish. Press **OK** to confirm.
4. Select a recipe. Press **OK** to confirm.

Recipes with Weight Automatic

This function automatically calculates the roasting time. To use it, it is necessary to input the food weight.

1. Turn on the oven.
2. Select the menu: Recipes. Press **OK** to confirm.
3. Select the category and dish. Press **OK** to confirm.
4. Select the function: Weight Automatic. Press **OK** to confirm.
5. Press **^** or **v** to set the food weight. Press **OK** to confirm.

The automatic programme starts.

6. You can change the weight at any time. Press **^** or **v** to change the weight.
7. When the time ends, a signal sounds. Press any symbol to turn off the signal.

i With some programmes turn over the food after 30 minutes. The display shows a reminder.

USING THE ACCESSORIES



WARNING! Refer to Safety chapters.

Inserting the accessories

Wire shelf:

Push the shelf between the guide bars of the shelf support and make sure that the feet point down.

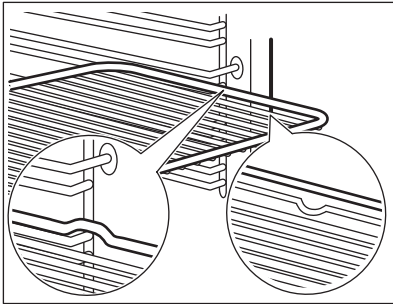

Deep pan:

Push the deep pan between the guide bars of the shelf support.

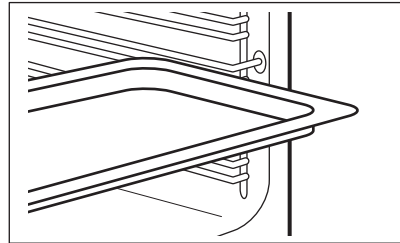

Wire shelf and deep pan together:

Push the deep pan between the guide bars of the shelf support and the wire shelf on the guide bars above.

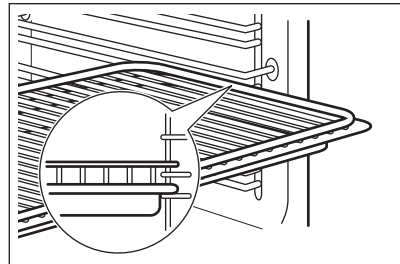

i Small indentation at the top increase safety. The indentations are also anti-tip devices. The high rim around the shelf prevents cookware from slipping of the shelf.

Accessories for steam cooking

The dietary baking dish for steam cooking functions

The dish consists of a glass bowl, a lid with a hole for the injector tube (C) and a steel grill to put at the bottom of the baking dish.

Glass bowl (A)

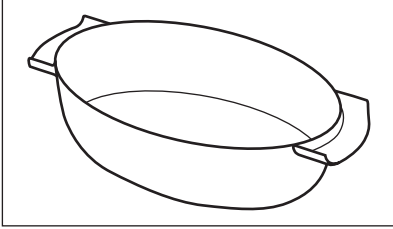

Lid (B)

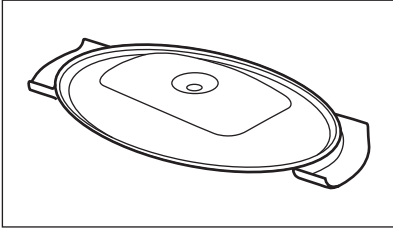

The injector and the injector tube

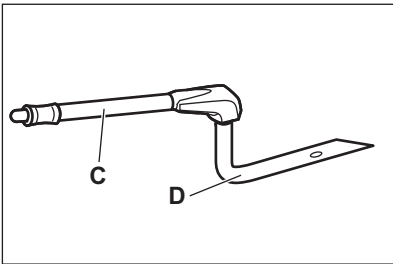

"C" is the injector tube for steam cooking,
"D" is the injector for direct steam cooking.

Injector tube (C)

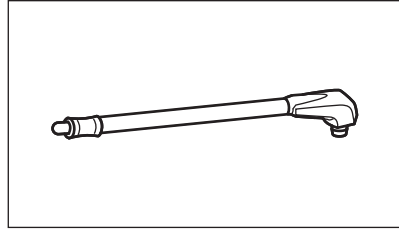

Injector for direct steam cooking (D)

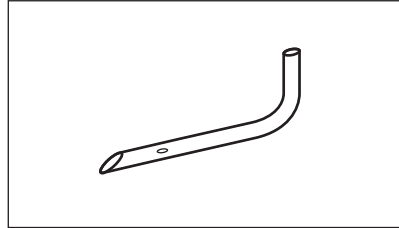

Steel grill (E)

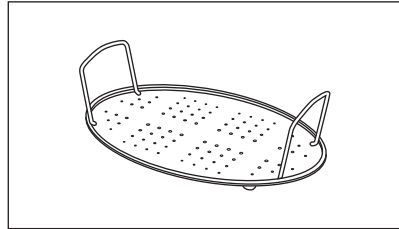

- Do not put the hot baking dish on cold / wet surfaces.

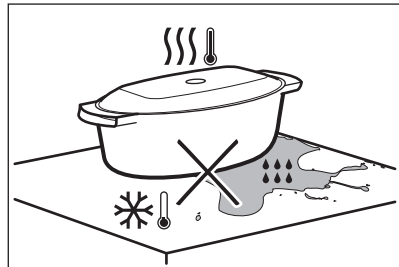

- Do not put cold liquids in the baking dish when it is hot.

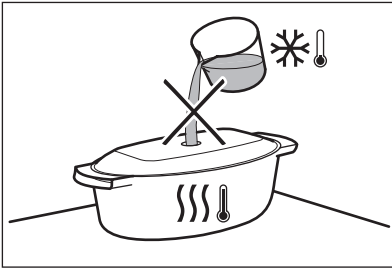

- Do not use the baking dish on a hot cooking surface.

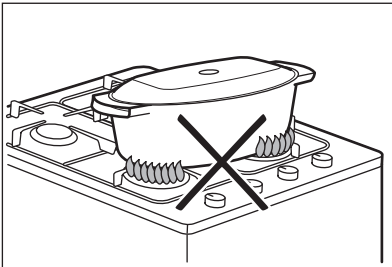

- Do not clean the baking dish with abrasives, scourers and powders.

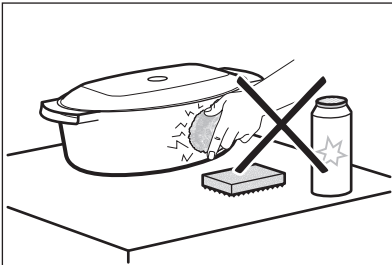

Steam cooking in a dietary baking dish

Put the food onto the steel grill in the baking dish and put the lid on it.

1. Put the injector tube into the special hole in the lid of the dietary baking dish.

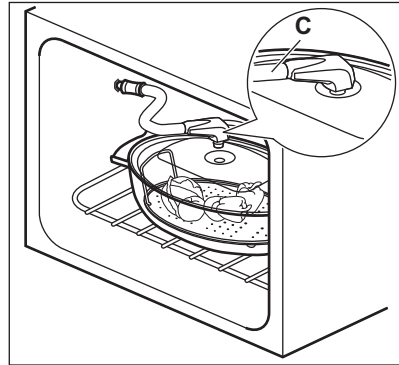

2. Put the baking dish onto the second shelf position from the bottom.
3. Put the other end of the injector tube into the steam inlet.

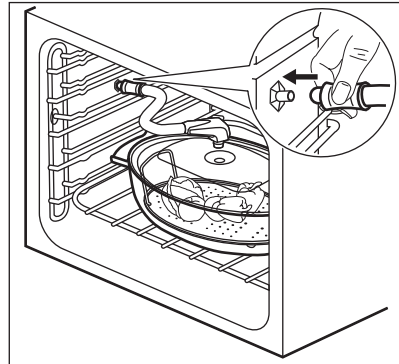

Make sure that you do not crush the injector tube or let it touch a heating element on the top of the oven.

4. Set the oven for the steam cooking function.

Direct steam cooking

Put the food onto the steel grill in the baking dish. Add some water.



CAUTION! Do not use the lid of the dish.



WARNING! Be careful when you use the injector when the oven operates. Always use oven gloves to touch the injector when the oven is hot. Always remove the injector from the oven when you do not use a steam function.



The injector tube is specially made for cooking and does not contain dangerous materials.

1. Put the injector (D) into the injector tube (C). Connect the other end into the steam inlet.

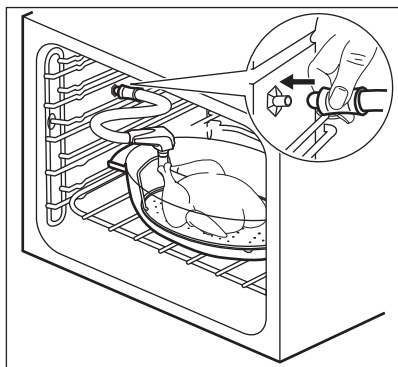

2. Put the baking dish onto the first or second shelf position from the bottom. Make sure that you do not crush the injector tube or let it touch a heating element on the top of the oven.
3. Set the oven for the steam cooking function.

When you cook food such as chicken, duck, turkey, kid or large fish, put the injector (D) directly into the empty part of the meat. Make sure that you do not cause a blockage of the holes.

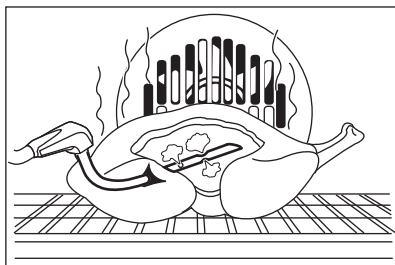

For more information about steam cooking, refer to the cooking tables for steam cooking in the chapter "Hints and Tips".

ADDITIONAL FUNCTIONS

Favourites

You can save your favourite settings, such as duration, temperature or heating function. They are available in the menu: Favourites. You can save 20 programmes.

Saving a programme

1. Turn on the oven.
2. Set a heating function or an automatic programme.
3. Press \odot again and again until the display shows: SAVE.
4. Press OK to confirm. The display shows the first free memory position.
5. Press OK to confirm.
6. Enter the name of the programme. The first letter flashes.
7. Press \vee or \wedge to change the letter.
8. Press OK. The next letter flashes.
9. Do step 7 again as necessary.
10. Press and hold OK to save. You can overwrite a memory position. When the display shows the first free memory position, press \vee or \wedge and press OK to overwrite an existing programme.

You can change the name of a programme in the menu: Edit Programme Name.

Activating the programme

1. Turn on the oven.
2. Select the menu: Favourites.
3. Press OK to confirm.
4. Select your favourite programme name.
5. Press OK to confirm.

You can press ☆ to go directly to menu: Favourites.

Using the Child Lock

When the Child Lock is on, the oven cannot be turned on accidentally.

1. Press ⏸ to turn on the display.
 2. Press ⏸ and ☆ at the same time until the display shows a message .
- To turn off the Child Lock function repeat step 2.

Function Lock

This function prevents an accidental change of the heating function. You can turn it on only when the oven works.

1. Turn on the oven.
2. Set a heating function or setting.
3. Press ⏸ again and again until the display shows: Function Lock.
4. Press OK to confirm.

To turn off the function, press ⏸. The display shows a message. Press ⏸ again and then OK to confirm.

 When you turn off the oven, the function also turns off.

Set + Go

The function lets you set a heating function (or a programme) and use it later with one press of any symbol.

1. Turn on the oven.
2. Set a heating function.
3. Press ⏸ again and again until the display shows: Duration.
4. Set the time.

5. Press ⏸ again and again until the display shows: Set + Go.

6. Press OK to confirm.



Press any symbol (except for ⏸) to start the function: Set + Go. The set heating function starts.

When the heating function ends, a signal sounds.

-  • Function Lock is on when the heating function works.
- The menu: Basic Settings lets you turn the function: Set + Go on and off.

Automatic Switch-Off

For safety reasons the oven turns off automatically after some time, if a heating function works and you do not change any settings.

 (°C)	 (h)
30 - 115	12.5
120 - 195	8.5
200 - 245	5.5
250 - maximum	3

The Automatic Switch-off does not work with the functions: Light, Duration, End Time.

Brightness of the display

There are two modes of display brightness:

- Night brightness - when the oven is turned off, the brightness of the display is lower between 10 PM and 6 AM.
- Day brightness:
 - when the oven is turned on.
 - if you touch a symbol during the night brightness (apart from ON / OFF), the display goes back to the day brightness mode for the next 10 seconds.

- if the oven is turned off and you set the function: Minute Minder. When the function ends, the display goes back to the night brightness.

Cooling fan

When the oven operates, the cooling fan turns on automatically to keep the surfaces of the oven cool. If you turn off the oven, the cooling fan can continue to operate until the oven cools down.

HINTS AND TIPS



WARNING! Refer to Safety chapters.



The temperature and baking times in the tables are guidelines only. They depend on the recipes and the quality and quantity of the ingredients used.

Cooking recommendations

The oven has five shelf positions.

Count the shelf positions from the bottom of the oven floor.

Your oven may bake or roast differently to the oven you had before. The below tables provide you with the standard settings for temperature, cooking time and shelf position.

If you cannot find the settings for a special recipe, look for the similar one.

The oven has a special system which circulates the air and constantly recycles the steam. With this system you can cook in a steamy environment and keep the food soft inside and crusty outside. It decreases the cooking time and energy consumption.

True Fan + Steam

Preheat the empty oven.

Safety thermostat

Incorrect operation of the oven or defective components can cause dangerous overheating. To prevent this, the oven has a safety thermostat which interrupts the power supply. The oven turns on again automatically when the temperature drops.

Baking cakes

Do not open the oven door before 3/4 of the set cooking time is up.

If you use two baking trays at the same time, keep one empty level between them.

Cooking meat and fish

Use a deep pan for very fatty food to prevent the oven from stains that can be permanent.







Leave the meat for approximately 15 minutes before carving so that the juice does not seep out.

To prevent too much smoke in the oven during roasting, add some water into the deep pan. To prevent the smoke condensation, add water each time after it dries up.





Cooking times

Cooking times depend on the type of food, its consistency, and volume.

Initially, monitor the performance when you cook. Find the best settings (heat setting, cooking time, etc.) for your cookware, recipes and quantities when you use this appliance.





 CAKES / PASTRIES				
	 (°C)	 (min)		
Tarts, preheating is not needed	175	30 - 40	2	Cake mould, Ø 26 cm
Fruit cake, preheating is not needed	160	80 - 90	2	Cake mould, Ø 26 cm
Panettone	150 - 160	70 - 100	2	Cake mould, Ø 20 cm
Plum cake	160	40 - 50	2	Bread tin
Biscuits, preheating is not needed	150	20 - 35	3 (2 and 4)	Baking tray
Sweet buns	180 - 200	12 - 20	2	Baking tray
Brioches	180	15 - 20	3 (2 and 4)	Baking tray





Use the cake mould.



 FLANS				
	 (°C)	 (min)		
Vegetables filled	170 - 180	30 - 40	1	
Lasagne	170 - 180	40 - 50	2	
Potato gratin	160 - 170	50 - 60	1 (2 and 4)	

Use the second shelf position.



Use the wire shelf.

 MEAT		
	 (°C)	 (min)
Roast pork, 1 kg	180	90 - 110
Veal, 1 kg	180	90 - 110



 MEAT		
	 (°C)	 (min)
Roast beef, rare, 1 kg	210	45 - 50
Roast beef, medium, 1 kg	200	55 - 65

MEAT		
		
	(°C)	(min)
Roast beef, well done, 1 kg	190	65 - 75



Use the second shelf position.



		
	(°C)	(min)
Lamb leg, 1 kg	175	110 - 130
Whole chicken, 1 kg	200	55 - 65
Whole turkey, 4 kg	170	180 - 240
Whole duck, 2 - 2.5 kg	170 - 180	120 - 150
Rabbit, cut in pieces	170 - 180	60 - 90

Use the first shelf position.

		
	(°C)	(min)
Whole goose, 3 kg	160 - 170	150 - 200

Use the second shelf position.

FISH		
		
	(°C)	(min)
Trout, 3 - 4 fish, 1.5 kg	180	25 - 35



FISH		
		
	(°C)	(min)
Tuna, 4 - 6 fillets, 1.2 kg	175	35 - 50
Hake	200	20 - 30

Cooking in the dietary baking dish



Use the function: True Fan + Steam.

Use the second shelf position.



Set the temperature to 130°C.

VEGETABLES	
	
	(min)
Tomatoes	15
Aubergines	15 - 20
Broccoli, florets	20 - 25
Courgette, slices	20 - 25
Pepper, strips	20 - 25
Cauliflower, florets	25 - 30
Kohlrabi	25 - 30
Asparagus, white	25 - 35
Celery, slices	30 - 35
Fennel	30 - 35
Asparagus, green	35 - 45
Carrots	35 - 40



Set the temperature to 130°C.



MEAT	
	 (min)
Poached chicken breast	25 - 35
Cooked ham	55 - 65
Kasseler	80 - 100

Set the temperature to 130°C.

FISH	
	 (min)
Trout / Salmon fillet	25 - 30

Set the temperature to 130°C.

SIDE DISHES	
	 (min)
Rice	35 - 40



SIDE DISHES	
	 (min)
Boiled potatoes, quartered	35 - 45
Polenta	40 - 45
Unpeeled potatoes, medium	50 - 60

Steam Regenerating







Preheat the empty oven.

Set the temperature to 130°C.

Use the second shelf position.

	 (min)
Pasta and sauce	10 - 15
Side dishes	10 - 15
One-Plate dish	10 - 15
Meat	10 - 15
Vegetables	10 - 15
Casseroles / Gratins	15 - 25

Baking and roasting

CAKES						
	Conventional Cooking		True Fan Cooking		 (min)	
	 (°C)		 (°C)			
Whisked recipes	170	2	160	3 (2 and 4)	45 - 60	Cake mould



CAKES

Conventional
Cooking

(°C)





True Fan Cook-
ing

(°C)











(min)









	Conventional Cooking		True Fan Cook- ing		(min)	
	 (°C)		 (°C)			
Shortbread dough	170	2	160	3 (2 and 4)	20 - 30	Cake mould
Buttermilk cheesecake	170	1	165	2	80 - 100	Cake mould, Ø 26 cm
Strudel	175	3	150	2	60 - 80	Baking tray
Jam tart	170	2	165	2	30 - 40	Cake mould, Ø 26 cm
Christmas cake, preheat the empty oven	160	2	150	2	90 - 120	Cake mould, Ø 20 cm
Plum cake, preheat the empty oven	175	1	160	2	50 - 60	Bread tin
Biscuits	140	3	140 - 150	3	25 - 45	Baking tray
Meringues	120	3	120	3	80 - 100	Baking tray
Meringues, preheat the empty oven, two levels	-	-	120	2 and 4	80 - 100	Baking tray
Buns, preheat the empty oven	190	3	190	3	12 - 20	Baking tray
Eclairs	190	3	170	3	25 - 35	Baking tray
Eclairs, two levels	-	-	170	2 and 4	35 - 45	Baking tray
Plate tarts	180	2	170	2	45 - 70	Cake mould, Ø 20 cm
Rich fruit cake	160	1	150	2	110 - 120	Cake mould, Ø 24 cm
Victoria sandwich	170	1	160	2	30 - 50	Cake mould, Ø 20 cm

Preheat the empty oven.

 BREAD AND PIZZA						
	Conventional Cook- ing		True Fan Cooking		 (min)	
	 (°C)		 (°C)			
White bread, 1 - 2 pieces, 0.5 kg each	190	1	190	1	60 - 70	-
Rye bread, preheating is not needed	190	1	180	1	30 - 45	Bread tin
Bread rolls, 6 - 8 rolls	190	2	180	2 (2 and 4)	25 - 40	Baking tray
Pizza	230 - 250	1	230 - 250	1	10 - 20	Baking tray / Deep pan
Scones	200	3	190	3	10 - 20	Baking tray





Preheat the empty oven.







Use the cake mould.

 FLANS						
	Conventional Cook- ing		True Fan Cooking		 (min)	
	 (°C)		 (°C)			
Pasta flan, preheating is not needed	200	2	180	2	40 - 50	
Vegetable flan, preheat- ing is not needed	200	2	175	2	45 - 60	
Quiches	180	1	180	1	50 - 60	
Lasagne	180 - 190	2	180 - 190	2	25 - 40	
Cannelloni	180 - 190	2	180 - 190	2	25 - 40	





Use the second shelf position.

Use the wire shelf.

 MEAT 	Conventional Cooking	True Fan Cooking	 (min)
	 (°C)	 (°C)	
Beef	200	190	50 - 70
Pork	180	180	90 - 120
Veal	190	175	90 - 120
English roast beef, rare	210	200	50 - 60
English roast beef, medium	210	200	60 - 70
English roast beef, well done	210	200	70 - 75

 MEAT 	Conventional Cooking		True Fan Cooking		 (min)
	 (°C)		 (°C)		
Pork shoulder, with rind	180	2	170	2	120 - 150
Pork shin, 2 pieces	180	2	160	2	100 - 120
Leg of lamb	190	2	175	2	110 - 130
Whole chicken	220	2	200	2	70 - 85
Whole turkey	180	2	160	2	210 - 240
Whole duck	175	2	220	2	120 - 150
Whole goose	175	2	160	1	150 - 200
Rabbit, cut in pieces	190	2	175	2	60 - 80
Hare, cut in pieces	190	2	175	2	150 - 200
Whole pheasant	190	2	175	2	90 - 120





Use the second shelf position.

 FISH			
	Conventional Cooking	True Fan Cooking	 (min)
	 (°C)	 (°C)	
Trout / Sea bream, 3 - 4 fish	190	175	40 - 55
Tuna / Salmon, 4 - 6 fillets	190	175	35 - 60

Bread Baking

Preheat the empty oven.





Use the second shelf position unless specified otherwise.





 BREAD				
	 (kg)	 (°C)	 (min)	
	White bread, 1 - 2 pieces, 0.5 kg for each	1	180 - 190	45 - 60
Bread rolls, 6 - 8 rolls	0.5	190 - 210	20 - 30	Baking tray, use the second and the fourth shelf position
Rye bread, 1 - 2 pieces, 0.5 kg for each	1	180 - 200	50 - 70	-
Focaccia	-	190 - 210	20 - 25	Baking tray

Crispy baking with: Pizza Setting

Preheat the empty oven.

Use the first shelf position unless specified otherwise.

 PIZZA			
	 (°C)	 (min)	
	Pizza, thin crust	200 - 220	15 - 25





 PIZZA			
	 (°C)	 (min)	
Pizza, thin crust	200 - 220	20 - 30	Baking tray
Mini pizza	200 - 220	15 - 20	Baking tray
Apple pie	150 - 170	50 - 70	Cake mould, Ø 20 cm
Tarts	170 - 190	35 - 50	Cake mould, Ø 26 cm
Onion tart, use the second shelf position	200 - 220	20 - 30	Baking tray

Grill

Preheat the empty oven.

Use the fourth shelf position.

Grill with the maximum temperature setting.





 GRILL			
	 (kg)	 (min) 1st side	 (min) 2nd side
Fillet steaks, 4 pieces	0.8	12 - 15	12 - 14
Beef steak, 4 pieces	0.6	10 - 12	6 - 8
Sausages, 8	-	12 - 15	10 - 12
Pork chops, 4 pieces	0.6	12 - 16	12 - 14
Chicken, half, 2	1	30 - 35	25 - 30
Kebabs, 4	-	10 - 15	10 - 12
Chicken breast, 4 pieces	0.4	12 - 15	12 - 14
Burgers, 6	0.6	20 - 30	-
Fish fillet, 4 pieces	0.4	12 - 14	10 - 12
Toasted sandwiches, 4 - 6	-	5 - 7	-
Toast, 4 - 6	-	2 - 4	2 - 3





Turbo Grilling





Preheat the empty oven.





Use the first or the second shelf position.





To calculate the roasting time multiple the time given in the table below by the centimetres of thickness of the fillet.





 BEEF	 (°C)	 (min)
		
Roast beef or fillet, rare	190 - 200	5 - 6
Roast beef or fillet, medium	180 - 190	6 - 8
Roast beef or fillet, well done	170 - 180	8 - 10





 PORK	 (°C)	 (min)
		
Shoulder / Neck / Ham joint, 1 - 1.5 kg	160 - 180	90 - 120
Chops / Spare rib, 1 - 1.5 kg	170 - 180	60 - 90
Meatloaf, 0.75 - 1 kg	160 - 170	50 - 60
Pork knuckle, precooked, 0.75 - 1 kg	150 - 170	90 - 120

 VEAL	 (°C)	 (min)
		
Roast veal, 1 kg	160 - 180	90 - 120
Veal knuckle, 1.5 - 2 kg	160 - 180	120 - 150

 LAMB	 (°C)	 (min)
		
Lamb leg / Roast lamb, 1 - 1.5 kg	150 - 170	100 - 120
Lamb saddle, 1 - 1.5 kg	160 - 180	40 - 60

 POULTRY	 (°C)	 (min)
		
Poultry, portions, 0.2 - 0.25 kg each	200 - 220	30 - 50
Chicken, half, 0.4 - 0.5 kg each	190 - 210	35 - 50
Chicken, poulard, 1 - 1.5 kg	190 - 210	50 - 70
Duck, 1.5 - 2 kg	180 - 200	80 - 100
Goose, 3.5 - 5 kg	160 - 180	120 - 180
Turkey, 2.5 - 3.5 kg	160 - 180	120 - 150





 POULTRY		
	 (°C)	 (min)
Turkey, 4 - 6 kg	140 - 160	150 - 240

 FISH (STEAMED)		
	 (°C)	 (min)
Whole fish, 1 - 1.5 kg	210 - 220	40 - 60





Slow Cooking





This function allows you to prepare lean, tender meat and fish. It is not applicable for: poultry, fatty roast pork, pot roast. .

1. Sear the meat for 1 - 2 minutes on each side in a pan over high heat.
2. Put the meat in the roasting pan or directly on the wire shelf. Put a tray below the wire shelf to collect fat. Always cook without a lid while using this function.
3. Select the function: Slow Cooking. You can set the temperature between 80 °C and 150 °C for the first 10 minutes. The default is 90 °C.
4. After 10 minutes, the oven automatically lowers the temperature to 80 °C.

 Set the temperature to 120 °C.			
	 (kg)	 (min)	
Steaks	0.2 - 0.3	20 - 40	3
Fillet of beef	1 - 1.5	90 - 150	3
Roast beef	1 - 1.5	120 - 150	1
Roast veal	1 - 1.5	120 - 150	1

Defrost

	 (kg)	 Defrosting time (min)	 Further defrosting time (min)	
Chicken	1	100 - 140	20 - 30	Place chicken on an upturned saucer placed on a large plate. Turn halfway through.

	 (kg)	 Defrosting time (min)	 Further defrost- ing time (min)	
Meat	1	100 - 140	20 - 30	Turn halfway through.
	0.5	90 - 120		
Cream	2 x 0.2	80 - 100	10 - 15	Cream can also be whipped when still slightly frozen in places.
Trout	0.15	25 - 35	10 - 15	-
Strawberries	0.3	30 - 40	10 - 20	-
Butter	0.25	30 - 40	10 - 15	-
Gateau	1.4	60	60	-

Preserving

Use only preserve jars of the same dimensions available on the market.

Do not use jars with twist-off and bayonet type lids or metal tins.

Use the first shelf position.

Put no more than six one-litre preserve jars on the baking tray.



Fill the jars equally and close with a clamp.



The jars cannot touch each other.



Put approximately 1/2 litre of water into the baking tray to give sufficient moisture in the oven.

When the liquid in the jars starts to simmer (after approximately 35 - 60 minutes with one-litre jars), stop the oven or decrease the temperature to 100 °C (see the table).

Set the temperature to 160 - 170 °C.

 SOFT FRUIT	 (min) Cooking time un- til simmering
Strawberries / Blueberries / Raspberries / Ripe gooseberries	35 - 45

 STONE FRUIT	 (min) Cooking time until simmering	 (min) Continue to cook at 100 °C
Peaches / Quinces / Plums	35 - 45	10 - 15

VEGETABLES		
	 (min) Cooking time until simmer- ing	 (min) Continue to cook at 100 °C
Carrots	50 - 60	5 - 10
Cucumbers	50 - 60	-
Mixed pick- les	50 - 60	5 - 10
Kohlrabi / Peas / As- paragus	50 - 60	15 - 20



Drying - True Fan Cooking



Cover trays with grease proof paper or baking parchment.

For a better result, stop the oven halfway through the drying time, open the door and let it cool down for one night to complete the drying.



For 1 tray use the third shelf position.

For 2 trays use the first and fourth shelf position.

VEGETABLES		
	 (°C)	 (h)
Beans	60 - 70	6 - 8



VEGETABLES		
	 (°C)	 (h)
Peppers	60 - 70	5 - 6
Vegetables for soup	60 - 70	5 - 6
Mushrooms	50 - 60	6 - 8
Herbs	40 - 50	2 - 3

Set the temperature to 60 - 70 °C.

FRUIT	
	 (h)
Plums	8 - 10
Apricots	8 - 10
Apple slices	6 - 8
Pears	6 - 9



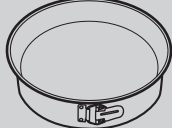

Moist Fan Baking - recommended accessories





Use the dark and non-reflective tins and containers. They have better heat absorption than the light colour and reflective dishes.

			
Pizza pan	Baking dish	Ramekins	Flan base tin
Dark, non-reflective 28 cm diameter	Dark, non-reflective 26 cm diameter	Ceramic 8 cm diameter, 5 cm height	Dark, non-reflective 28 cm diameter

Moist Fan Baking







For the best results follow suggestions listed in the table below.







		 (°C)		 (min)
Sweet rolls, 16 pieces	baking tray or dripping pan	180	2	20 - 30
Rolls, 9 pieces	baking tray or dripping pan	180	2	30 - 40
Pizza, frozen, 0.35 kg	wire shelf	220	2	10 - 15
Swiss roll	baking tray or dripping pan	170	2	25 - 35
Brownie	baking tray or dripping pan	175	3	25 - 30
Soufflè, 6 pieces	ceramic ramekins on wire shelf	200	3	25 - 30
Sponge flan base	flan base tin on wire shelf	180	2	15 - 25
Victoria sandwich	baking dish on wire shelf	170	2	40 - 50
Poached fish, 0.3 kg	baking tray or dripping pan	180	3	20 - 25
Whole fish, 0.2 kg	baking tray or dripping pan	180	3	25 - 35
Fish fillet, 0.3 kg	pizza pan on wire shelf	180	3	25 - 30







		 (°C)		 (min)
Poached meat, 0.25 kg	baking tray or dripping pan	200	3	35 - 45
Shashlik, 0.5 kg	baking tray or dripping pan	200	3	25 - 30
Cookies, 16 pieces	baking tray or dripping pan	180	2	20 - 30
Macaroons, 24 pieces	baking tray or dripping pan	180	2	25 - 35
Muffins, 12 pieces	baking tray or dripping pan	170	2	30 - 40
Savory pastry, 20 pieces	baking tray or dripping pan	180	2	25 - 30
Short crust biscuits, 20 pieces	baking tray or dripping pan	150	2	25 - 35
Tartlets, 8 pieces	baking tray or dripping pan	170	2	20 - 30
Vegetables, poached, 0.4 kg	baking tray or dripping pan	180	3	35 - 45
Vegetarian omelette	pizza pan on wire shelf	200	3	25 - 30
Mediterranean vegetables, 0.7 kg	baking tray or dripping pan	180	4	25 - 30

Information for test institutes

Tests according to IEC 60350-1.

				 (°C)	 (min)	
Small cakes, 20 per tray	Conventional Cooking	Baking tray	3	170	20 - 30	-

				 (°C)	 (min)	
Small cakes, 20 per tray	True Fan Cooking	Baking tray	3	150 - 160	20 - 35	-
Small cakes, 20 per tray	True Fan Cooking	Baking tray	2 and 4	150 - 160	20 - 35	-
Apple pie, 2 tins Ø20 cm	Conventional Cooking	Wire shelf	2	180	70 - 90	-
Apple pie, 2 tins Ø20 cm	True Fan Cooking	Wire shelf	2	160	70 - 90	-
Sponge cake, cake mould Ø26 cm	Conventional Cooking	Wire shelf	2	170	40 - 50	Preheat the oven for 10 minutes.
Sponge cake, cake mould Ø26 cm	True Fan Cooking	Wire shelf	2	160	40 - 50	Preheat the oven for 10 minutes.
Sponge cake, cake mould Ø26 cm	True Fan Cooking	Wire shelf	2 and 4	160	40 - 60	Preheat the oven for 10 minutes.
Short bread	True Fan Cooking	Baking tray	3	140 - 150	20 - 40	-
Short bread	True Fan Cooking	Baking tray	2 and 4	140 - 150	25 - 45	-
Short bread	Conventional Cooking	Baking tray	3	140 - 150	25 - 45	-

				 (°C)	 (min)	
Toast, 4 - 6 pieces	Grill	Wire shelf	4	max.	2 - 3 minutes first side; 2 - 3 minutes second side	Preheat the oven for 3 minutes.
Beef burger, 6 pieces, 0.6 kg	Grill	Wire shelf and dripping pan	4	max.	20 - 30	Put the wire shelf on the fourth level and the dripping pan on the third level of the oven. Turn the food halfway through the cooking time. Preheat the oven for 3 minutes.

CARE AND CLEANING



WARNING! Refer to Safety chapters.

Notes on cleaning



Cleaning Agents

Clean the front of the oven with a soft cloth with warm water and a mild cleaning agent.

To clean metal surfaces, use a dedicated cleaning agent.

Clean stubborn stains with a special oven cleaner.



Everyday Use

Clean the oven cavity after each use. Fat accumulation or other food remains may cause fire. The risk is higher for the grill pan.

Moisture can condense in the oven or on the door glass panels. To decrease the condensation, operate the oven for 10 minutes before cooking. Dry the cavity with a soft cloth after each use.



Accessories

Clean all accessories after each use and let them dry. Use a soft cloth with warm water and a cleaning agent. Do not clean the accessories in a dishwasher.

Do not clean the non-stick accessories using aggressive agents, sharp-edged objects or in a dishwasher.

Stainless steel or aluminium ovens

Clean the oven door with a damp cloth or sponge only. Dry it with a soft cloth.

Do not use steel wool, acids or abrasive materials as they can damage the oven surface. Clean the oven control panel with the same precautions.

Cleaning the door gasket

Regularly do a check of the door gasket. The door gasket is around the frame of the oven cavity. Do not use the oven if the door gasket is damaged. Contact an Authorised Service Centre.

To clean the door gasket, refer to the general information about cleaning.

Removing the shelf supports

To clean the oven, remove the shelf supports.



CAUTION! Be careful when you remove the shelf supports.

1. Pull the front of the shelf support away from the side wall.

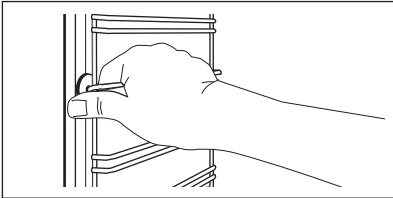

2. Pull the rear end of the shelf support away from the side wall and remove it.

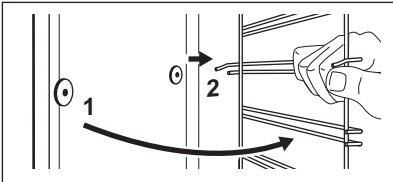

Install the removed accessories in the opposite sequence.

Cleaning the water tank



WARNING! Do not put water into the water tank during the cleaning procedure.



During the cleaning procedure, some water can drip from the steam inlet onto the cavity of the oven. Put a dripping pan on the shelf level directly below the steam inlet to prevent water from falling onto the bottom of the oven cavity.

After some time, you can have lime deposits in your oven. To prevent this, clean the parts of the oven that generate the steam. Empty the tank after each steam cooking.

Types of water

- **Soft water with low lime content** - the manufacturer recommends this because it decreases the quantity of cleaning procedures.
- **Tap water** - you can use it if your domestic water supply has purifier or water sweetener.
- **Hard water with high lime content** - it does not have an effect on the performance of the oven but it increases the quantity of cleaning procedures.

CALCIUM QUANTITY TABLE INDICATED FROM W.H.O. (World Health Organization)

Calcium deposit	Water hardness		Water classification	Run decalcification every
	(French degrees)	(German degrees)		
0 - 60 mg/l	0 - 6	0 - 3	Sweet or soft	75 cycles - 2.5 months
60 - 120 mg/l	6 - 12	3 - 7	Medium hardness	50 cycles - 2 months
120 - 180 mg/l	12 - 18	8 - 10	Hard or calcareous	40 cycles - 1.5 months
over 180 mg/l	over 18	over 10	Very hard	30 cycles - 1 month

1. Fill in the water tank with 850 ml of water and 50 ml of citric acid (five teaspoons). Turn off the oven and wait for approximately 60 minutes.
2. Turn on the oven and set the function: True Fan + Steam. Set the temperature 230 °C. Turn it off after 25 minutes and let it cool down for 15 minutes.
3. Turn on the oven and set the function: True Fan + Steam. Set the temperature between 130 and 230 °C. Turn it off after 10 minutes.

Let it cool down and continue with the removal of the tank contents. Refer to "Emptying the water tank".

4. Rinse the water tank and clean the remaining lime residue in the oven with a cloth.
5. Clean the drain pipe by hand in warm water with soap. To prevent damage, do not use acids, sprays or similar cleaning agents.

Removing and installing door

The oven door has three glass panels. You can remove the oven door and the internal glass panels to clean them. Read the whole "Removing and installing door" instruction before you remove the glass panels.



The oven door may close if you try to remove the glass panels before you remove the oven door.



CAUTION! Do not use the oven without the glass panels.

1. Fully open the door and find the hinge to the right side of the door.
2. Use a screwdriver to lift and turn fully the right side hinge lever.

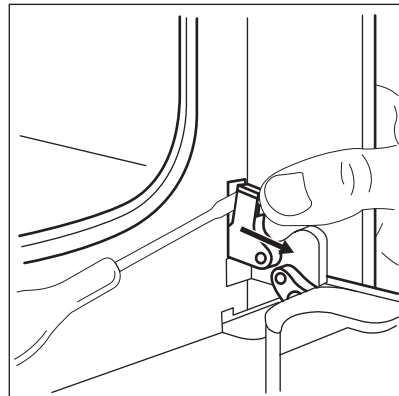

3. Find the hinge to the left side of the door.

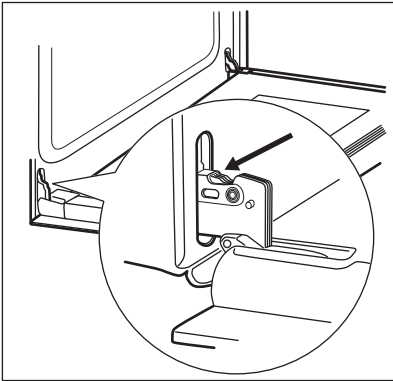

4. Lift and turn the lever fully on the left hinge.

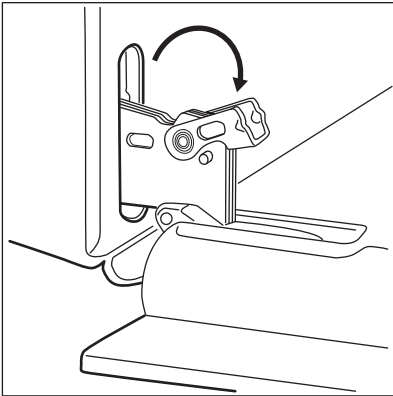

5. Close the oven door halfway to the first opening position. Then lift and pull forward and remove the door from its seat.

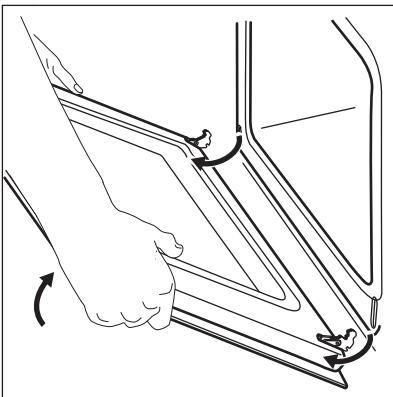

6. Put the door on a soft cloth on a stable surface.
7. Hold the door trim (B) on the top edge of the door at the two sides and push inwards to release the clip seal.

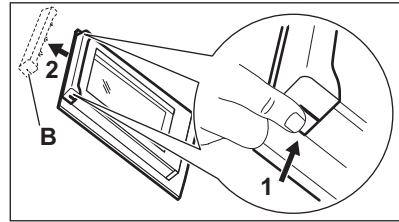

8. Pull the door trim to the front to remove it.
9. Hold the door glass panels by their top edge and carefully pull them out one by one. Start from the top panel. Make sure the glass slides out of the supports completely.

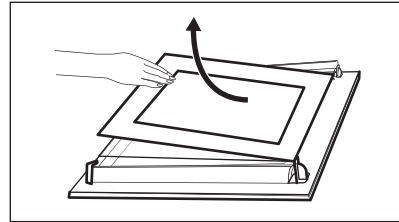

10. Clean the glass panels with water and soap. Dry the glass panels carefully. Do not clean the glass panels in the dishwasher.

When the cleaning is completed, install the glass panels and the oven door.

Make sure that you put the glass panels (A and B) back in the correct sequence. Check for the symbol / printing on the side of the glass panel, each of the glass panels looks different to make the disassembly and assembly easier.

When installed correctly the door trim clicks.

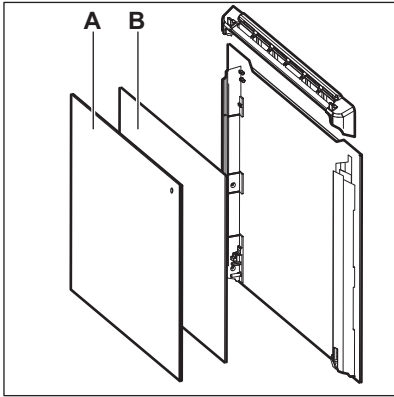

Make sure that you install the middle panel of glass in the seats correctly.

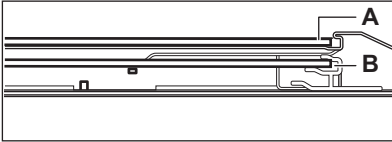

Replacing the lamp



WARNING! Risk of electric shock.
The lamp can be hot.

1. Turn off the oven.
Wait until the oven is cooled down.
2. Disconnect the oven from the mains.
3. Put a cloth on the bottom of the cavity.



CAUTION! Always hold the halogen lamp with a cloth to prevent grease residue from burning on the lamp.

The back lamp

1. Turn the lamp glass cover to remove it.
2. Clean the glass cover.
3. Replace the lamp with a suitable 300 °C heat-resistant lamp.
4. Install the glass cover.

TROUBLESHOOTING



WARNING! Refer to Safety chapters.

What to do if...

Problem	Possible cause	Remedy
You cannot activate or operate the oven.	The oven is not connected to an electrical supply or it is connected incorrectly.	Check if the oven is correctly connected to the electrical supply (refer to the connection diagram if available).
The oven does not heat up.	The oven is turned off.	Turn on the oven.
The oven does not heat up.	The clock is not set.	Set the clock.
The oven does not heat up.	The necessary settings are not set.	Make sure that the settings are correct.
The oven does not heat up.	The automatic switch-off is on.	Refer to "Automatic switch-off".
The oven does not heat up.	The Child Lock is on.	Refer to "Using the Child Lock".

Problem	Possible cause	Remedy
The oven does not heat up.	The fuse is blown.	Make sure that the fuse is the cause of the malfunction. If the fuse is blown again and again, contact a qualified electrician.
The lamp does not operate.	The lamp is defective.	Replace the lamp.
There is water inside the oven.	There is too much water in the tank.	Turn off the oven and wipe the water with a cloth or sponge.
The steam cooking does not work.	There is no water in the tank.	Fill the water tank.
The steam cooking does not work.	Lime obstructs the hole.	Check the steam inlet opening. Remove the lime.
It takes more than three minutes to empty the water tank or the water leaks from the steam inlet opening.	There are lime deposits in the oven.	Clean the water tank. Refer to "Cleaning the water tank".
The display shows an error code that is not in this table.	There is an electrical fault.	<ul style="list-style-type: none"> • Turn off the oven with the house fuse or the safety switch in the fuse box and turn it on again. • If the display shows the error code again, contact the Customer Care Department.
Steam and condensation settle on the food and in the cavity of the oven.	You left the dish in the oven for too long.	Do not leave the dishes in the oven for longer than 15 - 20 minutes after the cooking process ends.
The appliance is activated and does not heat up. The fan does not operate. The display shows " Demo ".	The demo mode is activated.	Refer to "Basic Settings" in "Daily use" chapter.

Service data

If you cannot find a solution to the problem yourself, contact your dealer or an Authorised Service Centre.

The necessary data for the service centre is on the rating plate. The rating plate is

on the front frame of the oven cavity. Do not remove the rating plate from the oven cavity.

We recommend that you write the data here:

Model (MOD.)
Product number (PNC)
Serial number (S.N.)

ENERGY EFFICIENCY

Product Information Sheet

Product information according to EU 65-66/2014

Supplier's name	Dieter Knoll Collection
Model identification	DKS38024XK 949494260
Energy Efficiency Index	81.2
Energy efficiency class	A+
Energy consumption with a standard load, conventional mode	0.93 kWh/cycle
Energy consumption with a standard load, fan-forced mode	0.69 kWh/cycle
Number of cavities	1
Heat source	Electricity
Volume	72 l
Type of oven	Built-In Oven
Mass	32.1 kg

EN 60350-1 - Household electric cooking appliances - Part 1: Ranges, ovens, steam ovens and grills - Methods for measuring performance.

Energy saving



The oven contains features which help you save energy during everyday cooking.

Make sure that the oven door is closed properly when the oven operates. Do not open the door too often during cooking. Keep the door gasket clean and make sure it is well fixed in its position.

Use metal cookware to improve energy saving.

When possible, do not preheat the oven before cooking.

Keep breaks between baking as short as possible when you prepare a few dishes at one time.

Cooking with fan

When possible, use the cooking functions with fan to save energy.

Residual heat

If a programme with the Duration or End Time selection is activated and the cooking time is longer than 30 minutes,

the heating elements automatically turn off earlier in some oven functions.

The fan and lamp continue to operate. When you turn off the oven, the display shows the residual heat. You can use that heat to keep the food warm.

When the cooking duration is longer than 30 minutes, reduce the oven temperature to minimum 3 - 10 minutes before the end of cooking. The residual heat inside the oven will continue to cook.

Use the residual heat to warm up other dishes.

Keep food warm

Choose the lowest possible temperature setting to use residual heat and keep a

meal warm. The residual heat indicator or temperature appears on the display.

Cooking with the lamp off

Turn off the lamp during cooking. Turn it on only when you need it.

Moist Fan Baking

Function designed to save energy during cooking.

When you use this function the lamp automatically turns off after 30 seconds. You may turn on the lamp again but this action will reduce the expected energy savings.

ENVIRONMENTAL CONCERNS

Recycle materials with the symbol . Put the packaging in relevant containers to recycle it. Help protect the environment and human health by recycling waste of electrical and electronic appliances. Do

not dispose of appliances marked with the symbol  with the household waste. Return the product to your local recycling facility or contact your municipal office.

