

LKZ:85340

Modellname / Model name / Nom du modèle / Modellnamn / Nome modello / Název modelu / Modelnaam / Ime modela / Numéro Modello / Modell neve / Название модели / Názov modelu / Ime modela / Denumire model / Наименование на модела / Nazwa modelu

**TOFTA**

Modellnummer / Number / Numéro du modèle / Numero / Номер на модела / modello / Číslo modelu / Modell száma / Éíslo modelu / Številka modela / Număr model / Broj modela / Modelnummer / Numer modelu

**XA1 E1 813** 

Type / Tipo / Típus / Typ / Тип / Tip

**813**

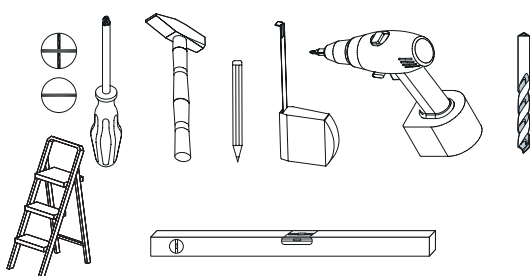
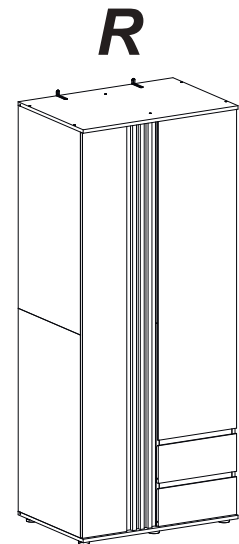
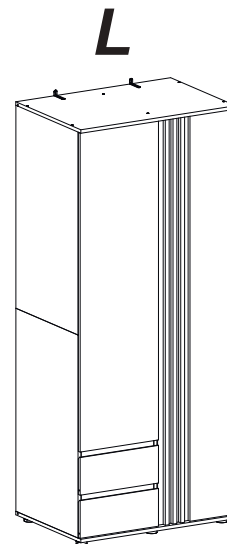
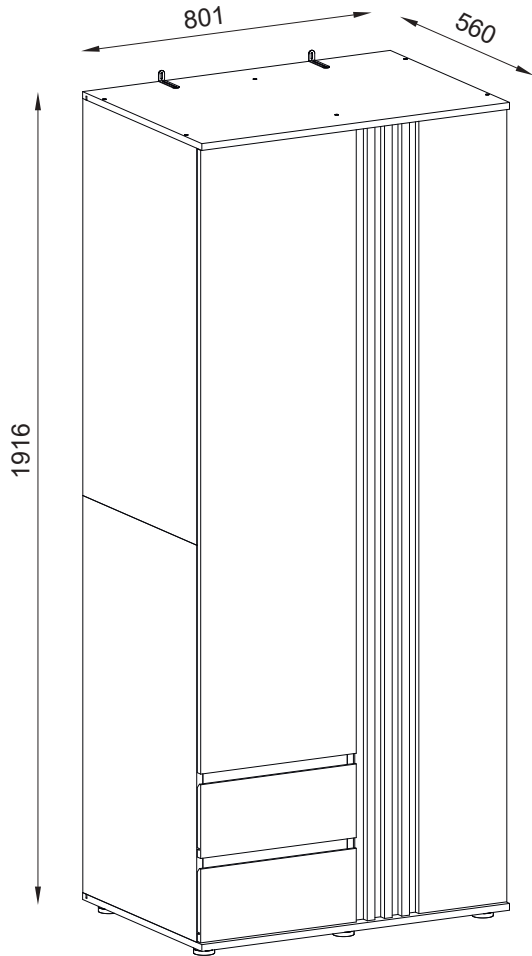
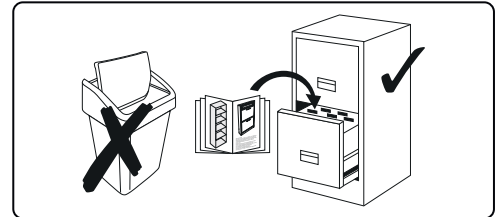
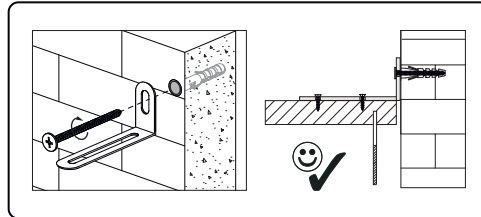
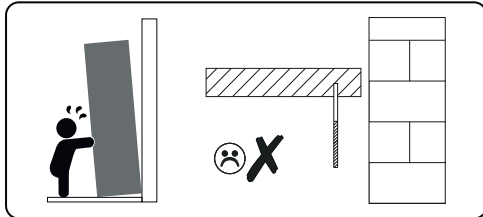
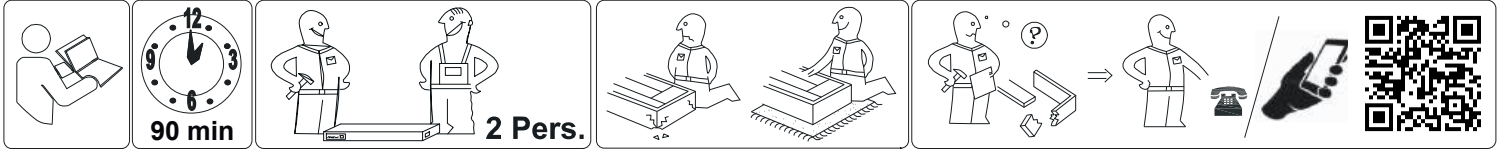

festziehen / tighten / Затягнете / serrer / stringere / utáhnout / vastrekken / zategnuti / strângere / zwiázac / zacisnac / szorosan meghúzni / pevne dotiahnuť / trdno pritegniti / затянуть / dra át

eindrücken / press in / enfoncer / wcisnac / ribattere / zatlacit' / Вкарайте / indrukken / benyomni / stlacit' / vtsniti / tryck in / introducere prin apásare / вдавить

ausmessen / measure / mesurer / misurare / opmeten / izmeriti / miara / kimérni / izmeriti / măsurare / измерить / změřit / Измерете / mät upp / zmierzyc



drücken / press / presser / stisknout / Натиснете / vtsniti / nasinac / drukken / pritisnuti / nacinac / pritisniti / нажать / (meg)nyomni / apásare / tryck fast / nacinac

einschlagen / hammer in / beverni / slain / frapper au marteau / infossare / Zabit' / zarazit / Набийте / zabiti / wbić / introducere prin bátaie / забить / zatlout

Drehen - wenden / przekrećić - odwrócić / Keren - omdraaien / Girare - Ruotare / Okrenuti - obrnuti / Retourner - renverser / Turn over - turn around / Otočte - obratite / Zavъртете - обърнете / Obrnite list / Întoarceți - rotiți / Vrid runt - vänd / прокрутить - повернуть / otočit - obrátit / otočit - obrátit / elforgatni - megfordítani

LKZ:85340

Modellname / Model name / Nom du modèle / Modellnamn  
Nome modello / Název modelu / Modelnaam / Ime modela  
Número Modelo / Modell neve / Назиме модели /  
Názov modelu / Ime modelu / Denumire model /  
Наименование на модела / Nazwa modelu

**TOFTA**

Modellnummer / Number / Numéro du modèle  
Numero / Номер на модела / modello  
Číslo modelu / Modell száma / Éíslo modelu  
Številka modela / Număr model / Broj modela  
Modelnummer / Numer modelu

**XA1 E1 813**

Type / Tipo / Típus / Typ / Тип / Tip

**813**

**D** Unser Direktservice für Beschlagteile  
Sollte Ihnen ein Beschlagteil fehlen, können Sie diese Servicekarte direkt an die untenstehende Adresse mailen. Wir können allerdings nur Beschlagteile auf diesem Wege verschicken. Sollten Sie eine andere Beanstandung an Ihrem Möbelstück haben, so wenden sie sich bitte direkt an Ihr Möbelhaus.

**GB** Our direct order service for fitting  
If a fitting part is missing, you can e-mail this service card directly to the address below. However, we can only send fitting parts in this way. If you have any other cause for complaint concerning your item of furniture, please contact your furniture store directly.

**CZ** Naše přímé služby pro kování  
Chybí-li vám nějaký díl z kování, můžete tuto servisní kartu odeslat e-mailem přímo na níže uvedenou adresu. Touto cestou však můžeme zoslat jen díly kování. Pokud byste reklamovali jiný díl nábytku, obraťte se přímo na svého prodejce nábytku.

**F** Bien étudier la notice de montage  
S'il vous manque une ferrure, veuillez envoyer directement la présente carte service à l'adresse e-mail indiquée ci-dessous. Cependant, ceci nous permet uniquement d'envoyer des ferrures. Pour tout autre type de réclamation concernant votre meuble, veuillez contacter directement votre magasin d'ameublement.

**I** Il nostro servizio diretto per l'ordine della ferramenta  
Qualora Vi dovesse mancare un pezzo di fissaggio, allora Vi preghiamo di inviare questa carta di servizio immediatamente all'indirizzo sottostante. Possiamo inviare i pezzi di fissaggio solamente per mezzo di questo procedimento. Qualora dovete avere qualche altra reclamazione in merito al mobile, allora Vi preghiamo di rivolgerVi direttamente al Vostro Negozio di mobili.

**BG** Нашата директна услуга за обко  
Ако липсват части от комплекта, попълнете настоящата сервисна карта и ни я изпратете на e-mail адреса, посочен по-долу. По този начин можем да доставим само липсващи елементи от обкоа. Ако установите други дефекти по мебелите, Ви съветваме да се обърнете към мебелната къща/магазин, от който сте закупили стоката.

**NL** Onze directservice voor losse onderdelen  
Wanneer er een onderdeel ontbreekt, kunt u deze servicekaart direct aan onderstaand e-mailadres sturen. Wij kunnen langs deze weg echter alleen beslagdelen versturen. Mocht u een ander probleem aan uw meubel hebben, verzoeken wij u contact op te nemen met uw meubeldealer.

**PL** Nasz bezpośredni serwis czesci montazowych  
Jeżeli brakuje czesci koniecznych do montazu, prosimy o przeslanie nam niniejszej karty serwisowej na nizszej podany adres e-mailowy. W ten sposob mozemy przeslac Państwu tylko brakujace czesci. W przypadku innych reklamacji dotyczacych mebla, prosimy zglosic sie do salonu meblowego, w którym zostal dokonany zakup.

**HR** Servis za okove  
U slučaju da nedostaje neki od dijelova molimo vas da na dolje navedenu mail adresu pošaljete ovaj servisni obrazac. Na ovaj način mogu se dostaviti samo okovi. U slučaju da imate dodatne prigovore vezane uz komad namještaja molimo vas da se obratite izravno trgovini namještaja gdje je isti kupljen.

**HU** Direktszolgáltatunk vasalatok esetén  
Ha hiányzik egy vasalat, ezt a kártyát közvetlenül elküldheti az alább található címre. Azonban csakis vasalatoskat tudunk így küldeni. Amennyiben másfajta reklamáció áll fenn bútordarabját illetően, forduljon közvetlenül a bútornához.

**SK** Náš priamy servis pre časti kovania  
Ak by Vám chýbala nejaká časť kovania, môžete poslať túto servisnú kartu poslať e-mailom na nižšie uvedenú adresu. Diely kovania vieme poslať iba týmto spôsobom. Ak by ste mali inú reklamáciu ohľadom Vášho nábytku, obraťte sa priamo na Vašu predajňu nábytku.

**SLO** Naše direktne uslužne storitve za okovje  
Če vam manjka kakšno okovje, lahko to servisno kartico pošljete po e-pošti direktno na spodnji naslov. Po tej poti vam lahko pošljemo samo okovje. Če želite reklamirati kakšen drug del pohištva, se obrnite neposredno na vašo trgovino pohištva.

**RO** Servise-ul nostru direct pentru feronerie  
În cazul în care vă lipsește o piesă de feronerie puteți să trimiteți direct acest card de service prin e-mail la adresa de mai jos. Noi nu putem expedia piese de feronerie decât pe această cale. Dacă aveți o altă reclamație referitoare la piesa de mobilier, atunci vă rugăm să vă adresați direct la magazinul dvs. de mobilă.

**RUS** Наш прямой сервис для поставок фурнитуры  
Если окажется, что Вам не хватает того или иного элемента фурнитуры, Вы можете отправить сервисную карту по факсу непосредственно на нижеприведенный адрес электронной почты. Однако, таким образом мы можем переслать лишь фурнитуру. Если же у Вас возникнут иные претензии относительно приобретенной мебели, пожалуйста, обращайтесь непосредственно в организацию, осуществившую продажу.

**S** Vår direktservice för beslagsdelar  
Om du saknar en beslagsdel kan du skicka detta servicekort direkt till e-postadressen som anges nedan. Tänk på att detta är den enda möjligheten att skicka beslagsdelar till dig. Om du vill reklamera din möbel av en annan anledning måste du kontakta ditt möbelhus direkt.

**ES** Nuestro servicio directo para accesorios  
Si le falta algún accesorio, puede enviar esta tarjeta de servicio directamente a la siguiente dirección. No obstante, por este método solo podemos enviar accesorios. Si tiene alguna otra objeción sobre su mueble, consulte directamente con su mueblería.

**TR** Donatılar için doğrudan servisimiz  
Bir donatınız eksikse bu servis kartını doğrudan aşağıda bulunan adrese doğrudan mail yazabilirsiniz. Sadece bu yolla donatıları gönderebiliriz. Mobilyanızda başka şikayetleriniz varsa lütfen doğrudan mobilya satıcınıza danışın.

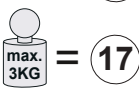
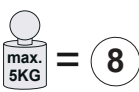
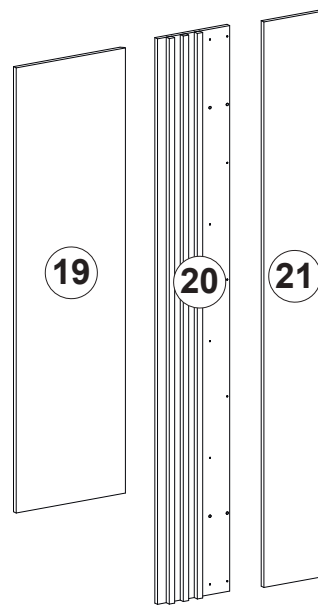
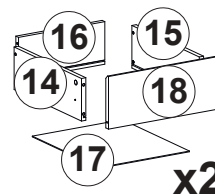
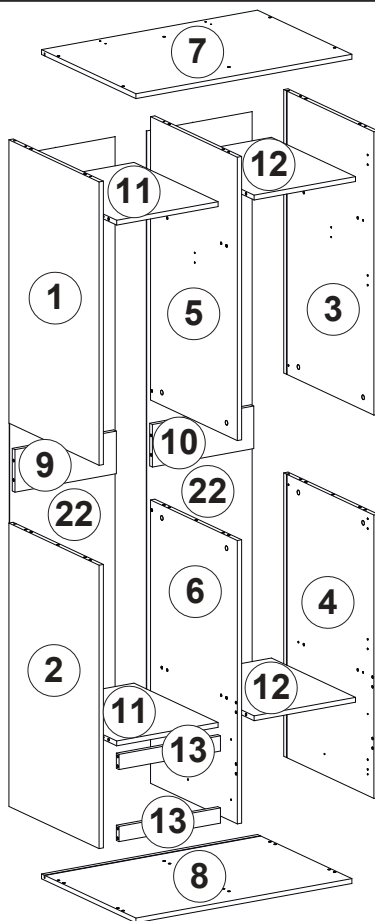

A	B (mm)	C	D
1	932 535	16 x1	1/3
2	932 535	16 x1	2/3
3	932 535	16 x1	1/3
4	932 535	16 x1	1/3
5	932 515	16 x1	1/3
6	932 515	16 x1	1/3
7	801 560	16 x1	2/3
8	801 560	16 x1	2/3
9	376 140	16 x1	2/3
10	376 140	16 x1	2/3
11	376 499	16 x2	2/3
12	376 499	16 x2	2/3

A	B (mm)	C	D
13	376 50	16 x2	2/3
14	400 140	16 x2	2/3
15	400 140	16 x2	2/3
16	320 140	16 x2	2/3
17	334 398	2.5 x2	3/3
18	405 173	16 x2	3/3
19	1464 405	16 x1	3/3
20	1860 240	34 x1	3/3
21	1860 229	16 x1	3/3
22	1878 391	2.5 x2	3/3
B1			1/3

Grund der Beanstandung / Reason of the objection:

---

Möbelhaus / Furniture store:

---

Name / Name: \_\_\_\_\_ Telefon / Telephone: \_\_\_\_\_

---

PLZ / postal code: \_\_\_\_\_ Ort / City: \_\_\_\_\_

---

Strasse / Street: \_\_\_\_\_

---

Haus-Nr. / House No.: \_\_\_\_\_ @E-Mail: \_\_\_\_\_

E-Mail Kundenservice / Customer service e-mail / E-mail servisního střediska / E-mail de notre service clientèle / E-mail на отдела за обслужване на клиенти / E-mail klantenservice / E-mail servisu dla klientów / Servisna mail adresa / Az ügyfélszolgálat e-mail címe / E-mail zákaznického servisu / E-pošta Servisna služba / E-mail Serviciu clienți / E-Mail сервисной службы / E-postadress kundservice / Servicio de atención por correo electrónico / Müşteri hizmetleri e-postası

service@xonox-home.com  
Hotline xonox.home GmBH  
0049 – (0) 5261 – 92020 – 0

LKZ:85340

Modellname / Model name / Nom du modèle / Modellnamn  
Nome modello / Název modelu / Modelnaam / Ime modela  
Numéro Modelo / Modell neve / Название модели /  
Názov modelu / Ime modela / Denumire model /  
Наименование на модела / Nazwa modelu

**TOFTA**











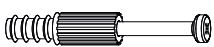

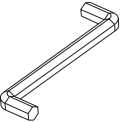
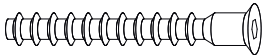
Modellnummer / Number / Numéro du modèle  
Numero / Номер на модела / modello  
Číslo modelu / Modell száma / Éíslo modelu  
Številka modela / Număr model / Broj modela  
Modelnummer / Numer modelu

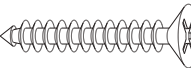
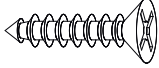
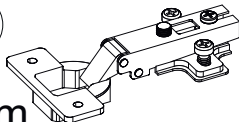
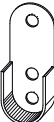
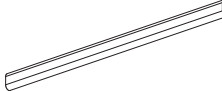
**XA1 E1 813**

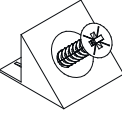
Type / Tipo / Típus / Тип / Тип / Tip

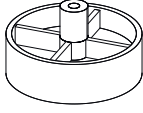
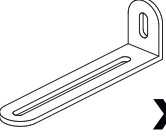
**813**

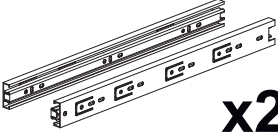
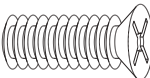
## B1 Colli 1/3

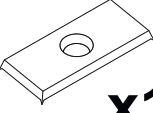
<b>A1</b> 15x12  <b>x38</b>	<b>C2</b> 44mm  <b>x16</b>	<b>B2</b> 8x30  <b>x32</b>
<b>FA1</b> 4mm  <b>x1</b>	<b>F3</b> 6,3x50  <b>x20</b>	<b>B5</b> 8x20  <b>x4</b>
<b>C3</b> 84mm  <b>x11</b>	<b>D26</b> 4x30  <b>x10</b>	<b>D11</b> 3,5x16  <b>x36</b>
<b>K6</b> ø35mm  <b>x7</b>	<b>Q1</b> 30x15mm  <b>x4</b>	<b>Q2</b> 372x23x15mm  <b>x2</b>
<b>DA20</b> 4,2x13  <b>x8</b>	<b>E4</b> 5x9  <b>x8</b>	<b>M1</b> 10x10x15  <b>x26</b>
<b>O1</b> ø18mm  <b>x28</b>	<b>P17</b> 48x20  <b>x6</b>	<b>Y36</b> 75x25x15  <b>x2</b>
<b>B4</b> 8x50  <b>x14</b>	<b>L4</b> 400mm  <b>x2</b>	<b>E6</b> 5x13  <b>x8</b>
<b>O2</b> ø12mm  <b>x20</b>	<b>S4</b> 20x10x2mm  <b>x10</b>	

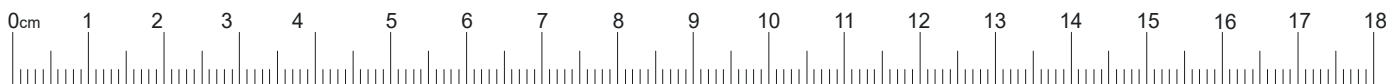

1

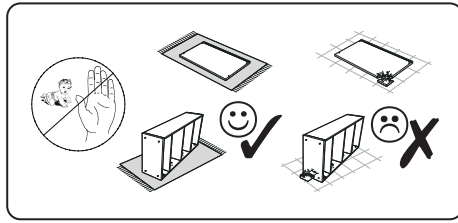

<b>F3</b>		6,3x50	<b>x8</b>
<b>FA1</b>		4mm	<b>x1</b>
<b>A1</b>		15x12	<b>x4</b>
<b>C2</b>		44mm	<b>x4</b>
<b>B2</b>		8x30	<b>x4</b>

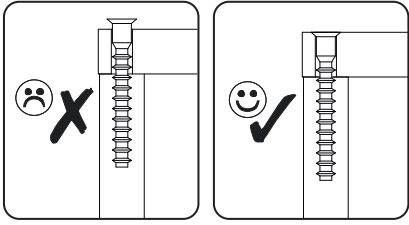

**A**

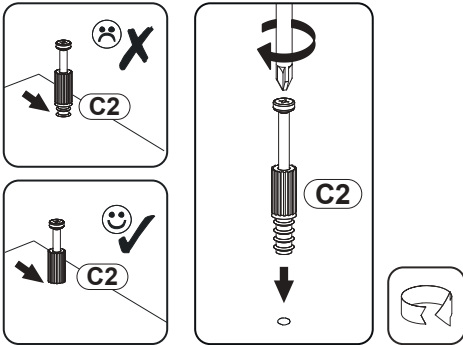
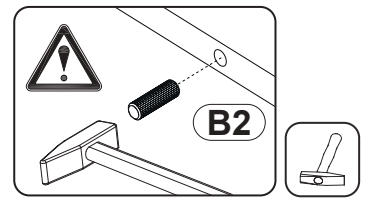
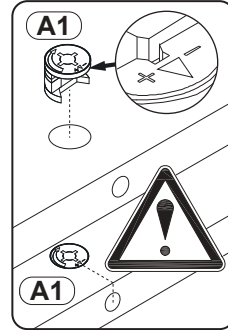
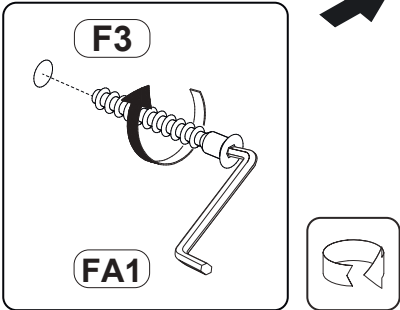
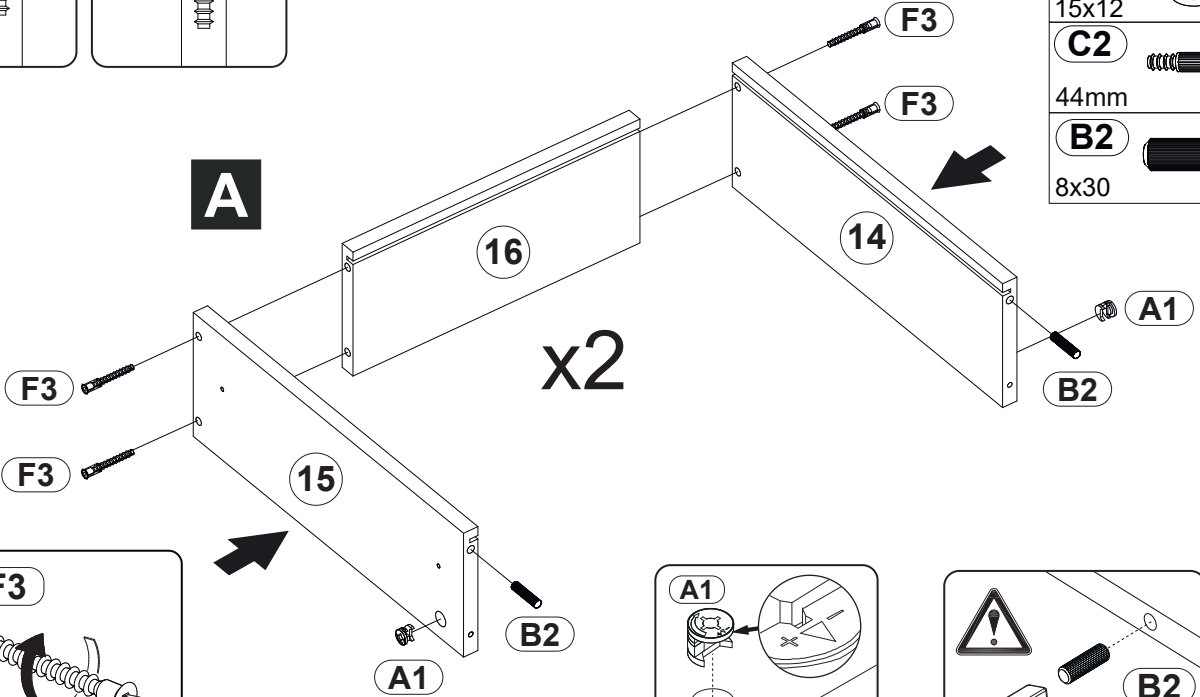

**B**

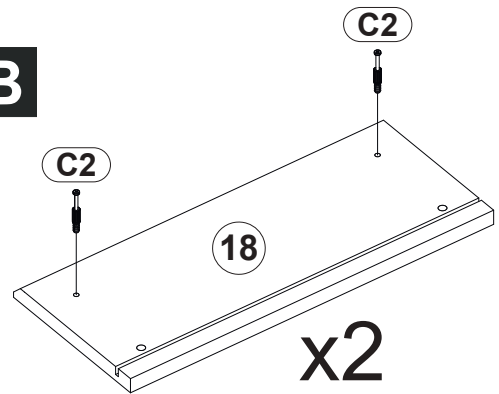

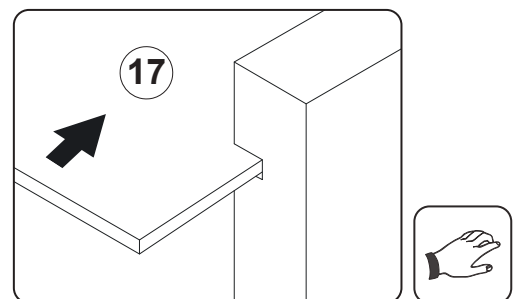
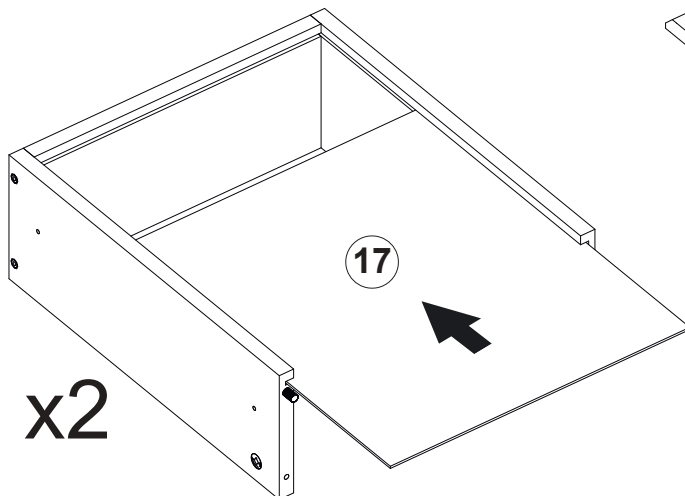

**C**

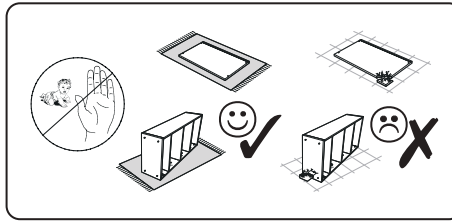

2

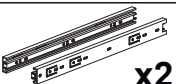
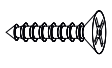

- O1**   $\varnothing 18\text{mm}$  **x4**
- L4**  400mm **x2**
- D11**  3,5x16 **x8**
- M1**  10x10x15 **x8**

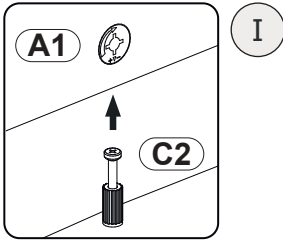

I

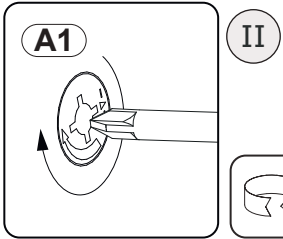

II

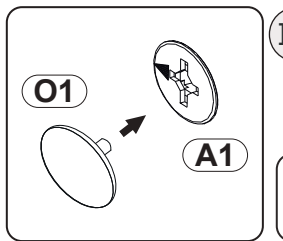

III

**D**

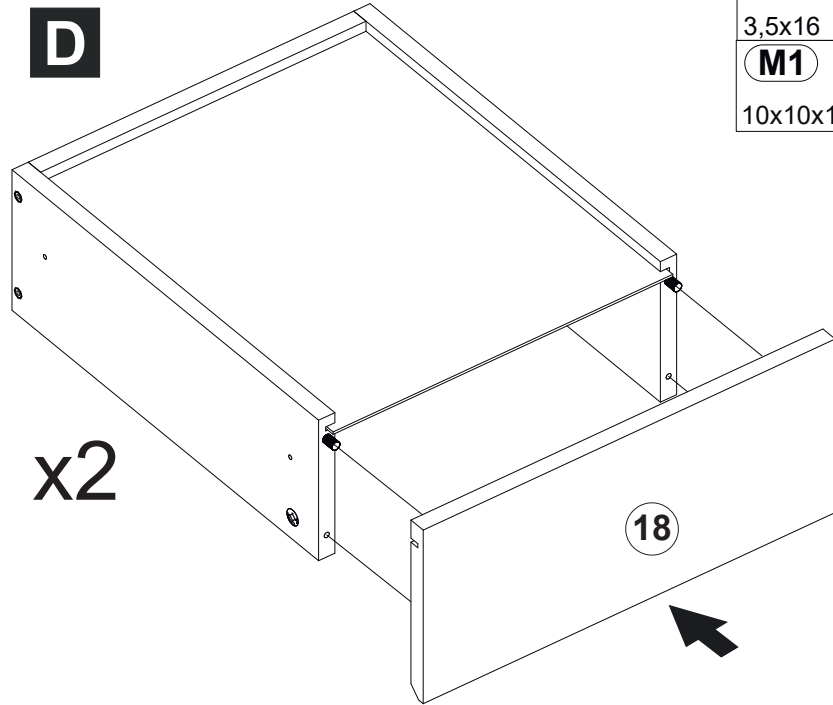

x2

18

**E**

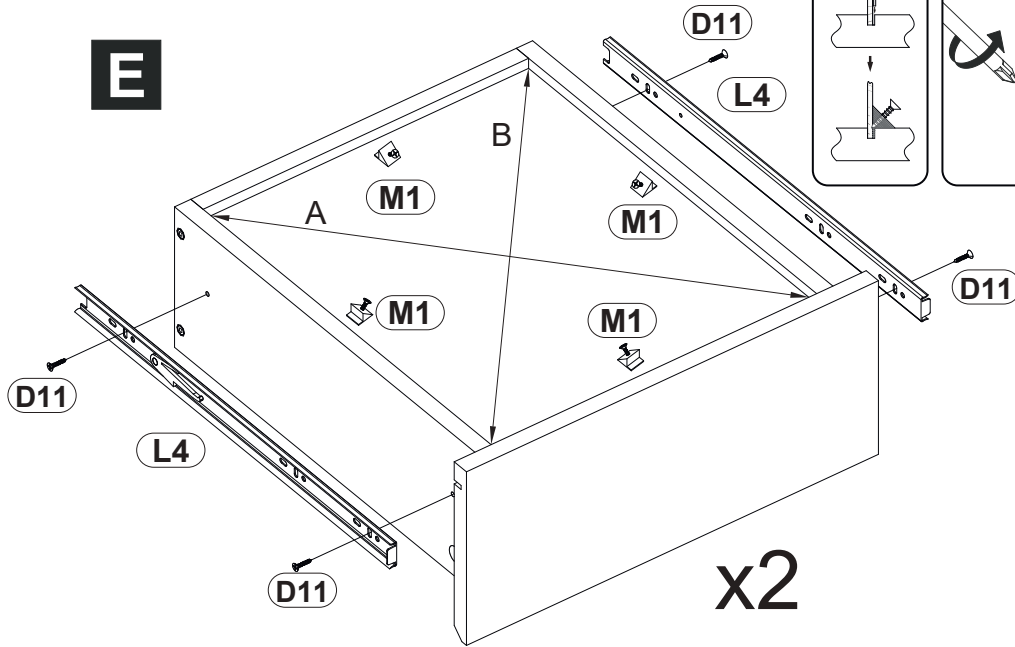

x2

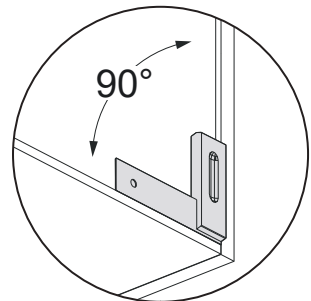
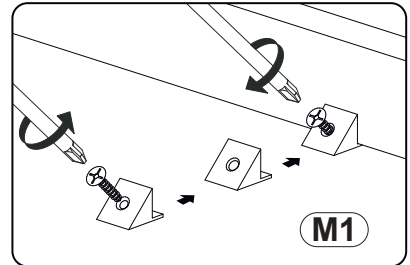
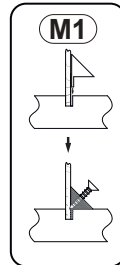

90°



A=B

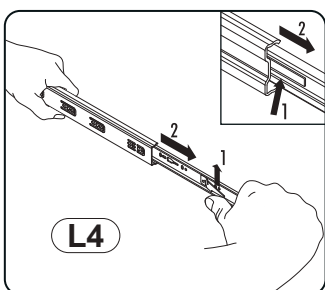

L4

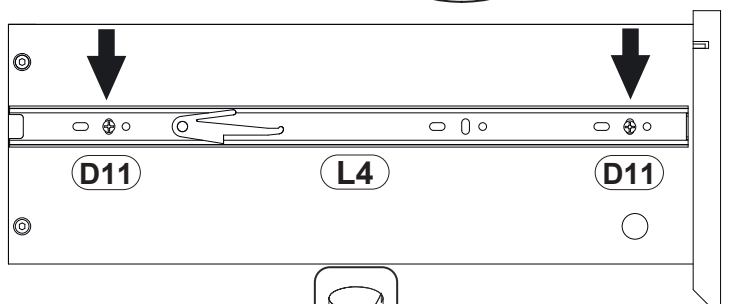

D11

L4

D11



3

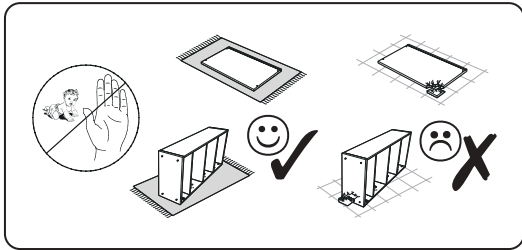

<b>A1</b>		<b>x4</b>
15x12		
<b>C2</b>		<b>x6</b>
44mm		
<b>B2</b>		<b>x4</b>
8x30		
<b>E4</b>		<b>x2</b>
5x9		
<b>Q1</b>		<b>x1</b>
30x15mm		
<b>B4</b>		<b>x3</b>
8x50		

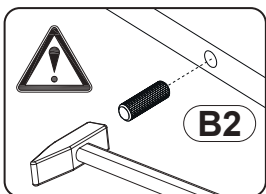
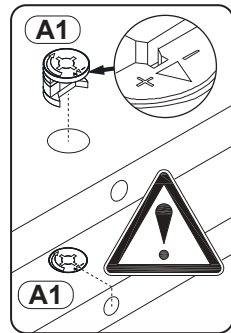
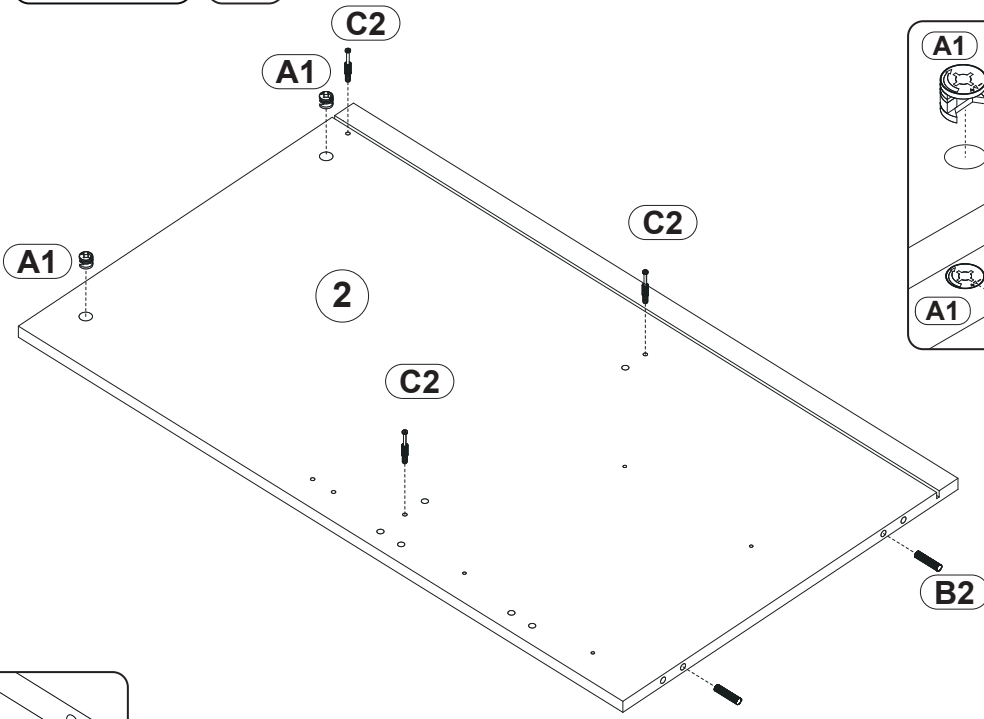
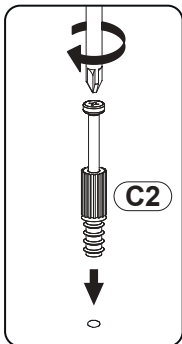
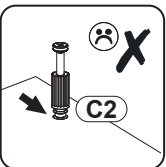
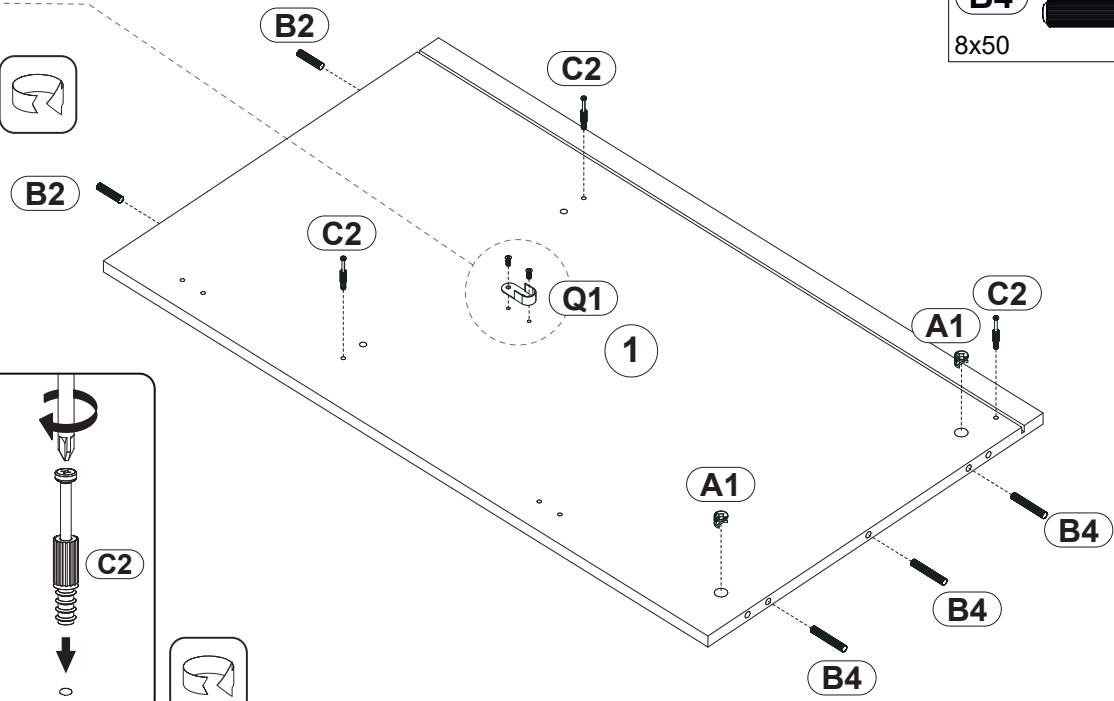
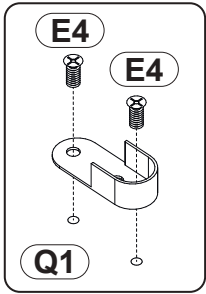

4

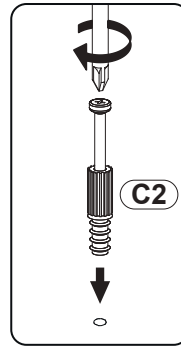
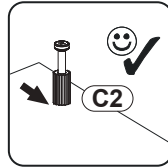
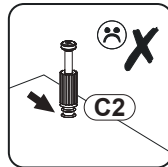
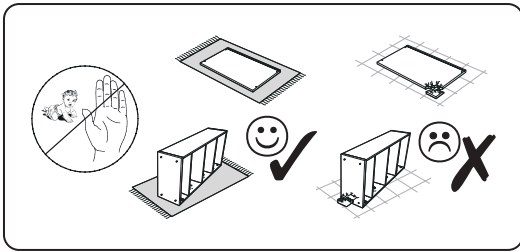



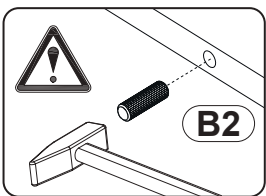
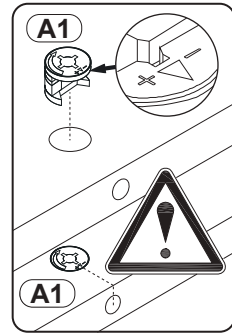
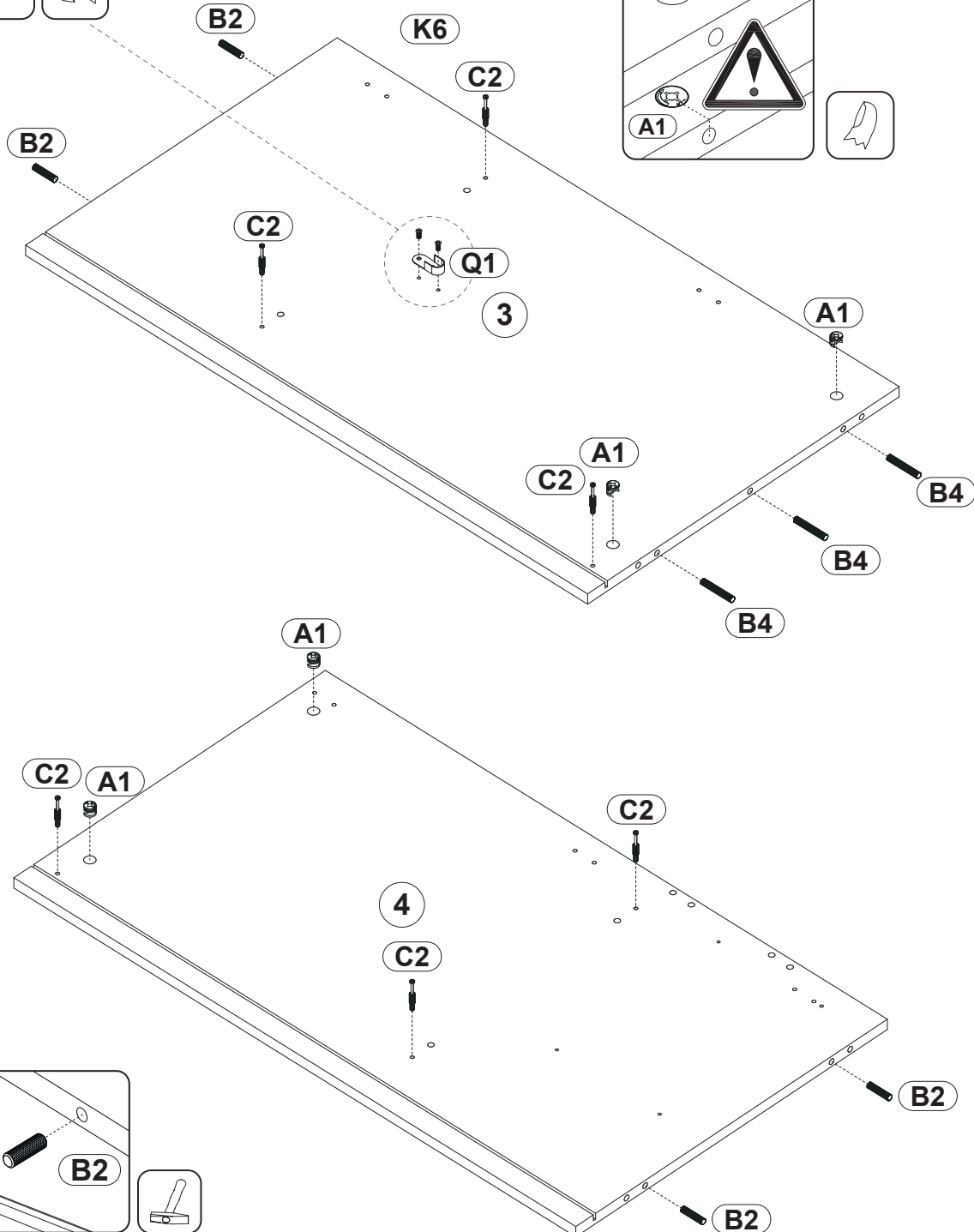
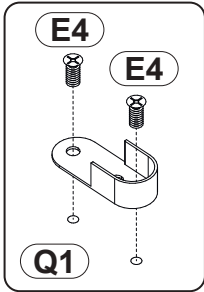

<b>A1</b>		<b>x4</b>
15x12		
<b>C2</b>		<b>x6</b>
44mm		
<b>B2</b>		<b>x4</b>
8x30		
<b>E4</b>		<b>x2</b>
5x9		
<b>Q1</b>		<b>x1</b>
30x15mm		
<b>B4</b>		<b>x3</b>
8x50		

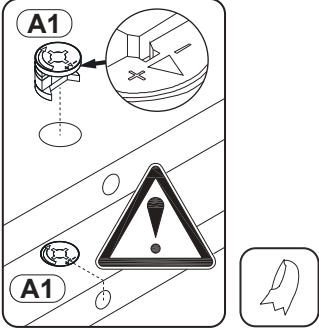
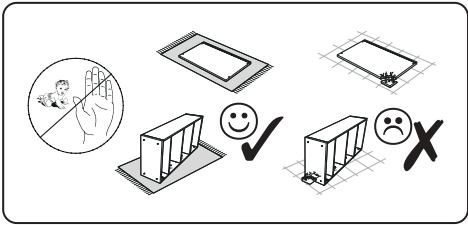



5

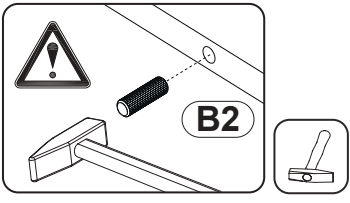
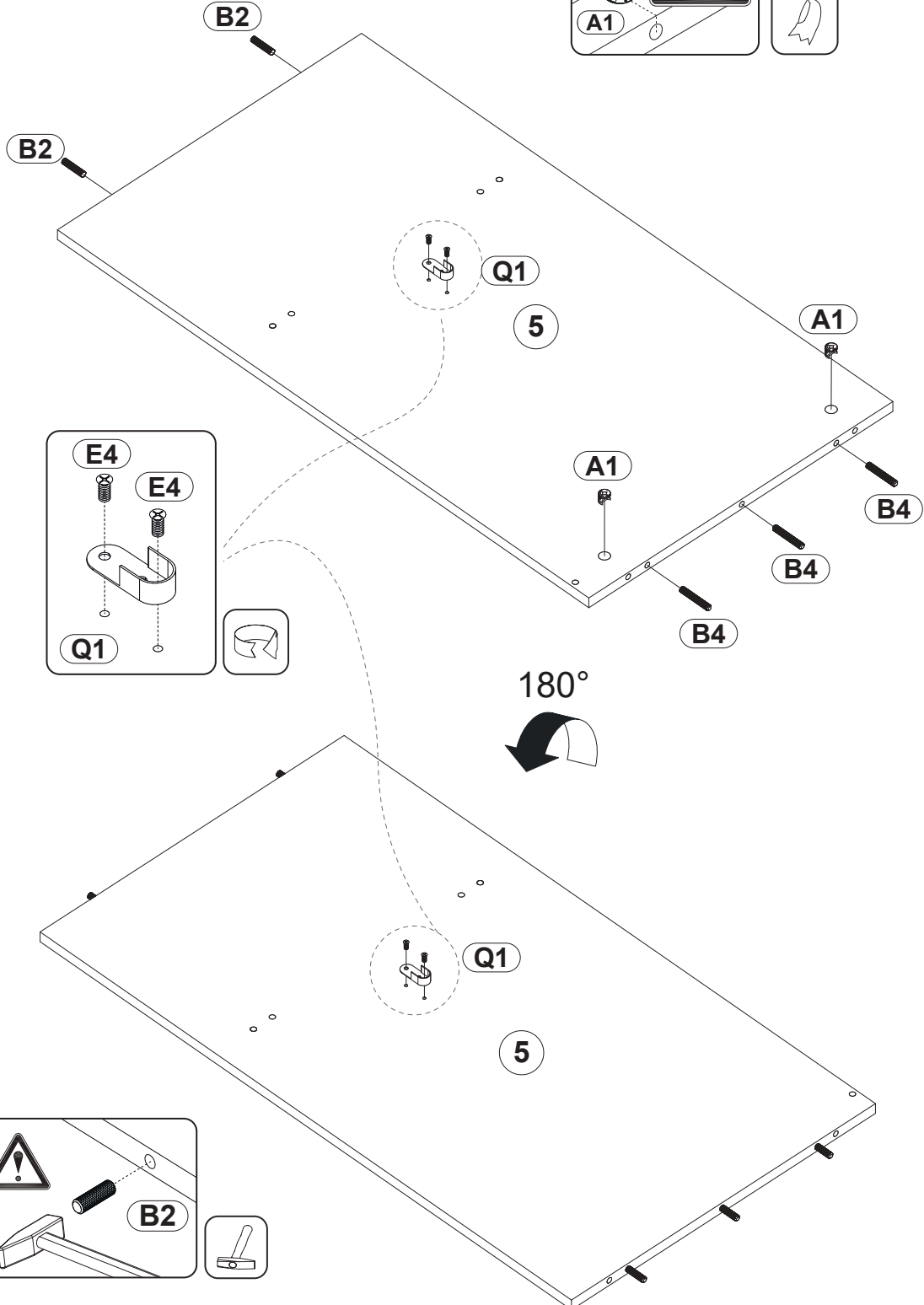

<b>A1</b>		<b>x2</b>
15x12		
<b>B2</b>		<b>x2</b>
8x30		
<b>E4</b>		<b>x4</b>
5x9		
<b>Q1</b>		<b>x2</b>
30x15mm		
<b>B4</b>		<b>x3</b>
8x50		



6

<b>A1</b>		<b>x24</b>
15x12		
<b>B2</b>		<b>x18</b>
8x30		

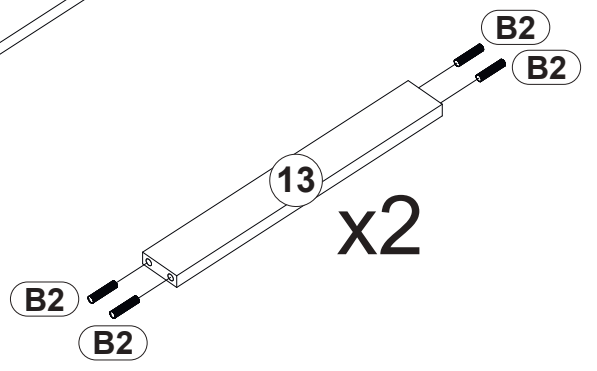
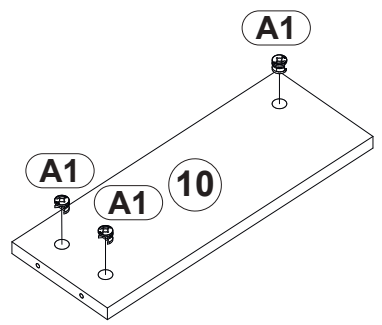
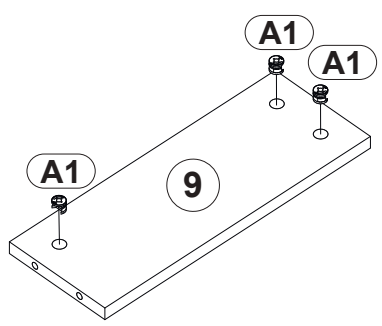
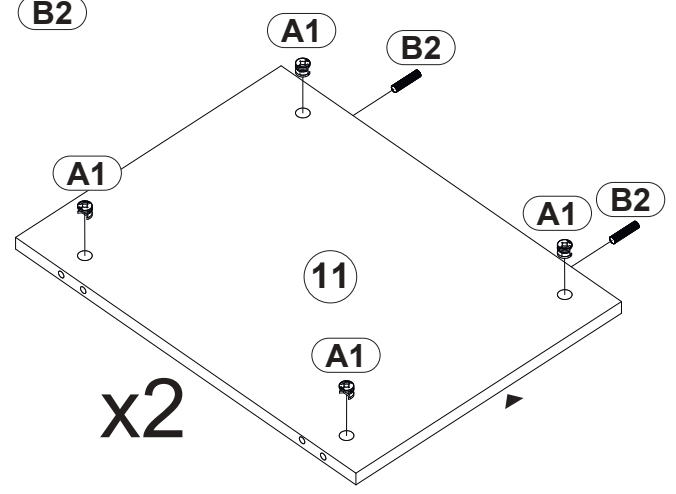
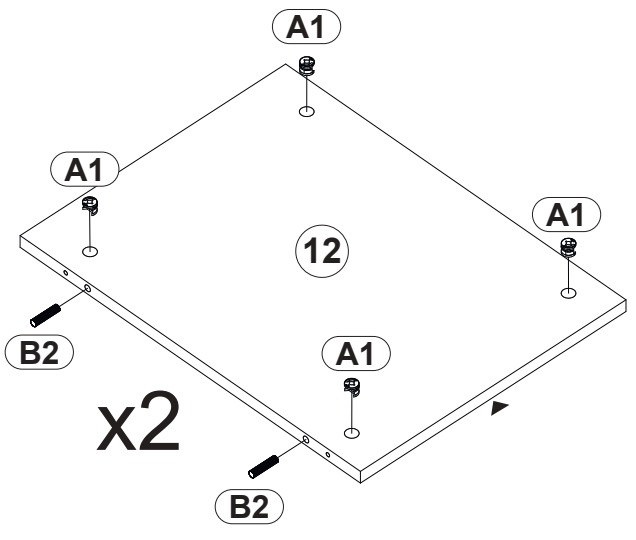
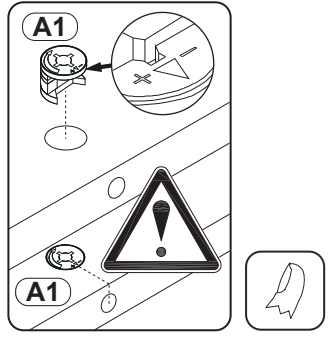
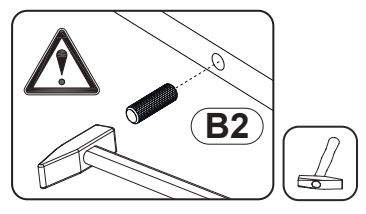
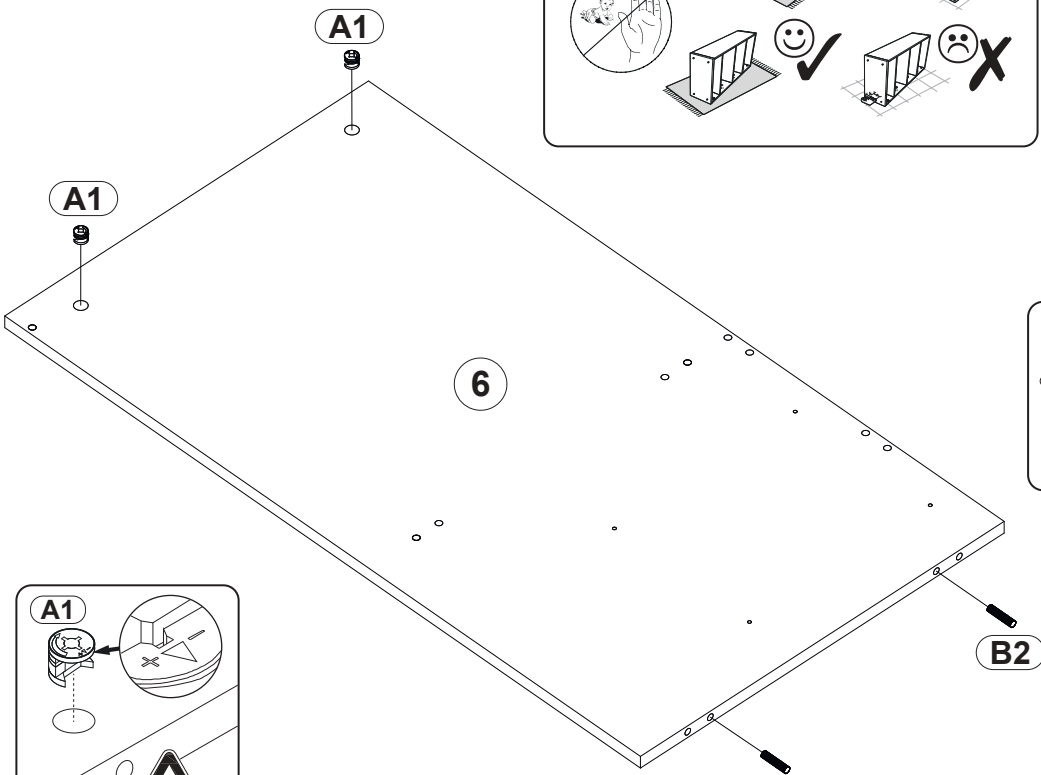
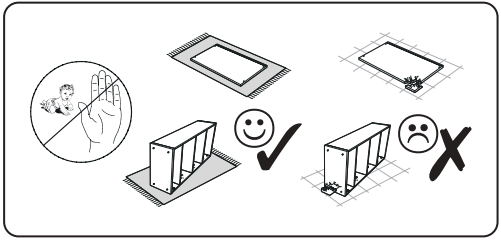

7

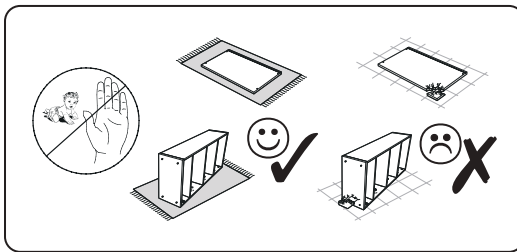

- C3** 84mm x4
- O1** ø18mm x8

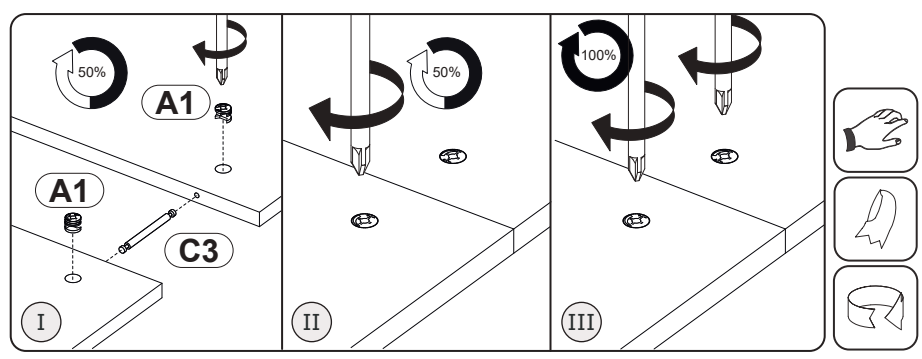
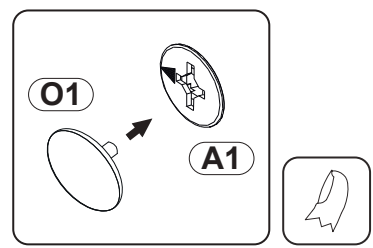
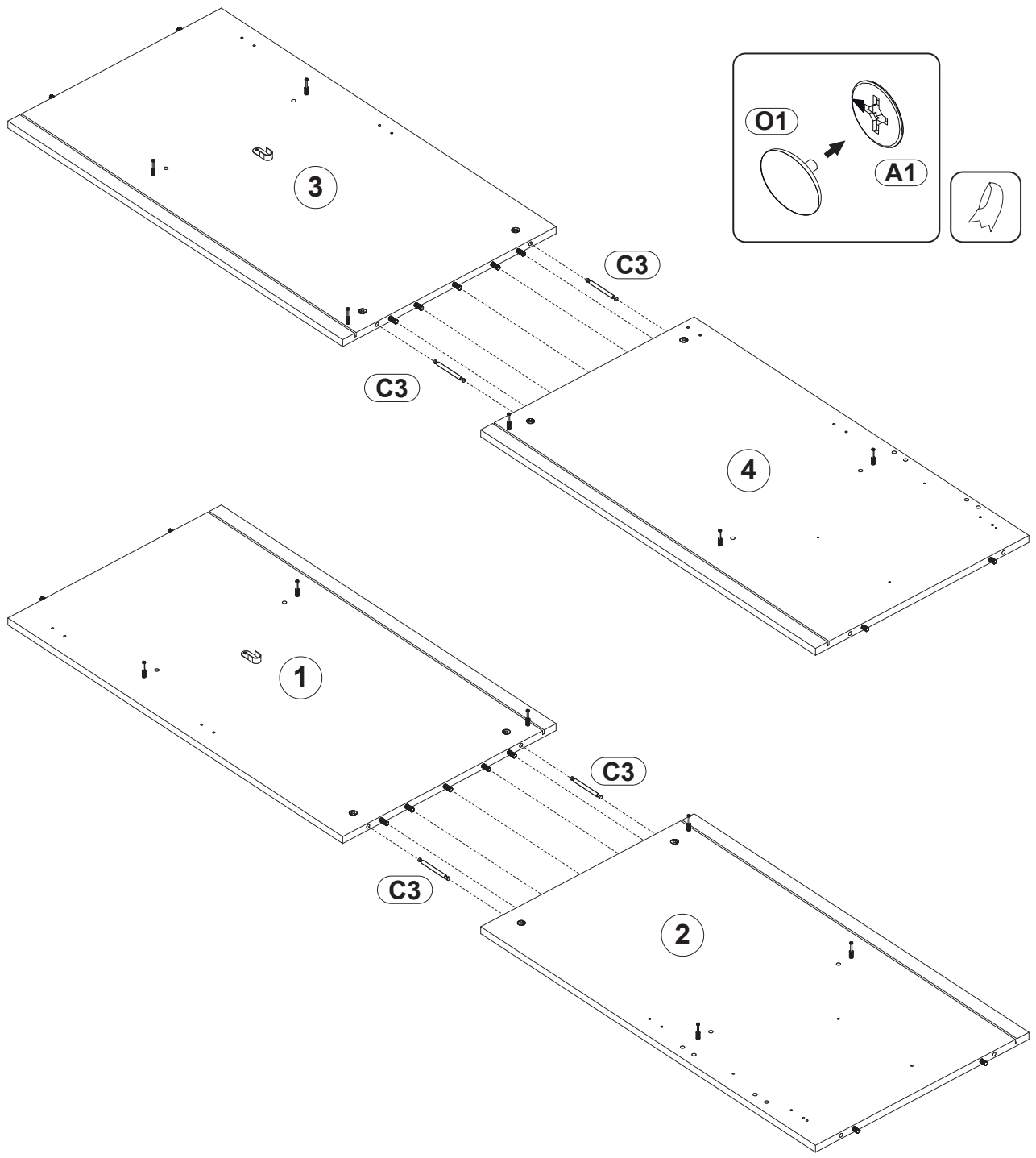

8

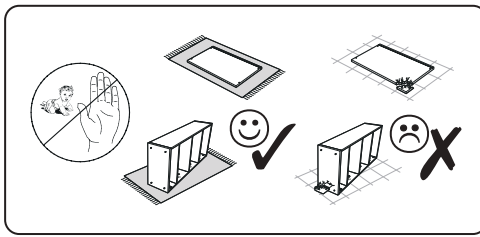

<b>C3</b>		84mm	x7
<b>O1</b>		ø18mm	x4
<b>B4</b>		8x50	x5

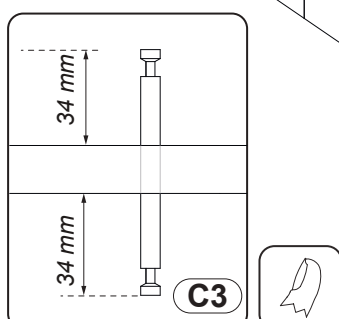
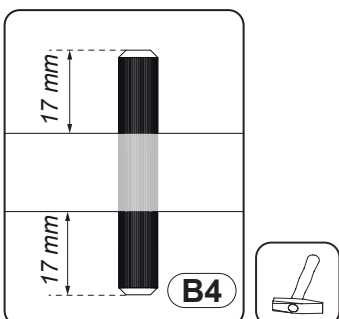
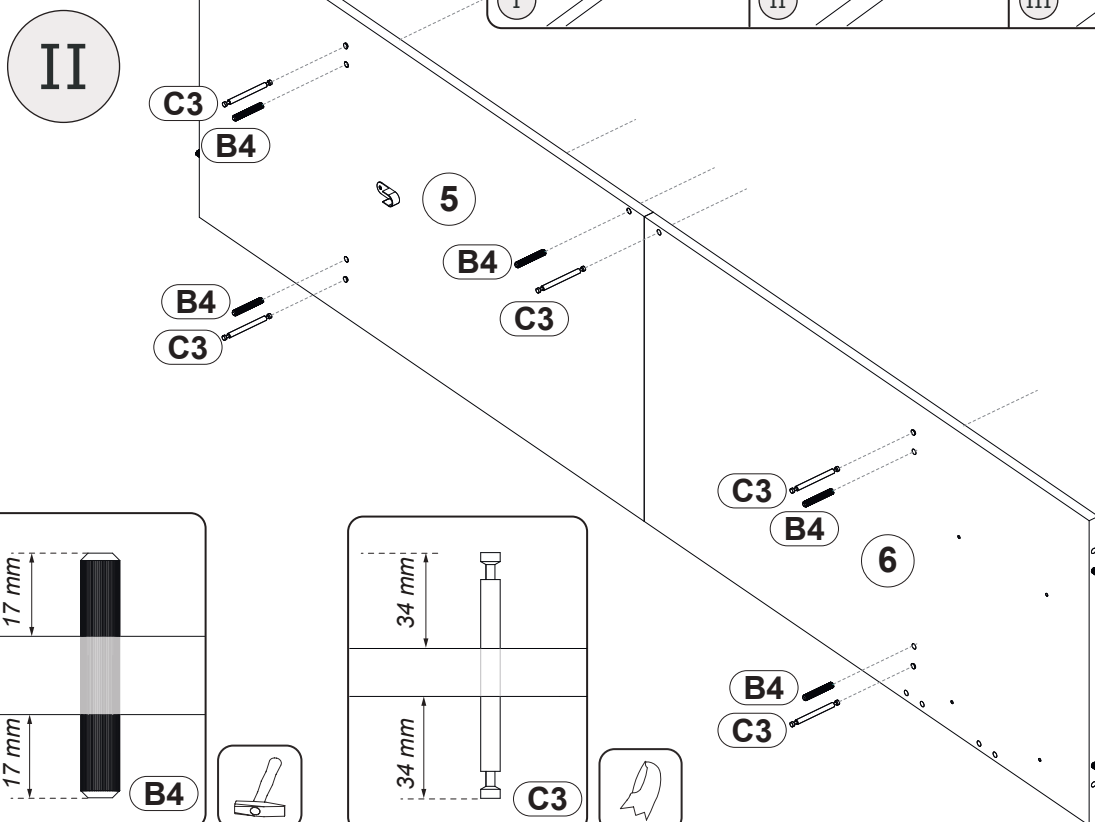
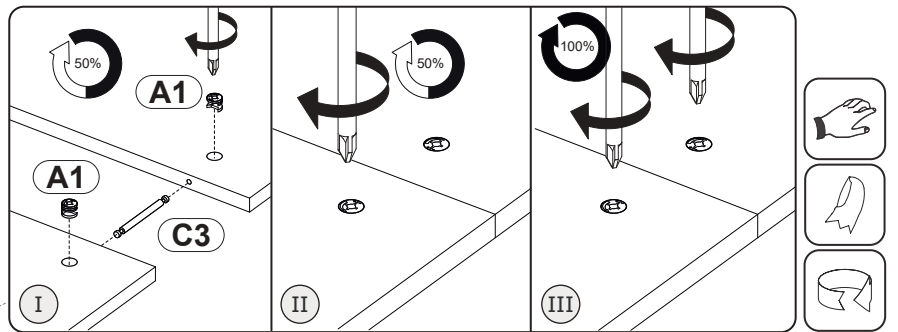
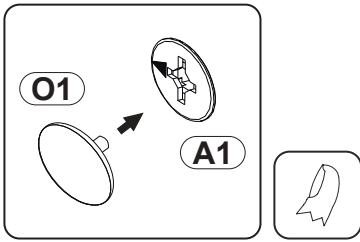
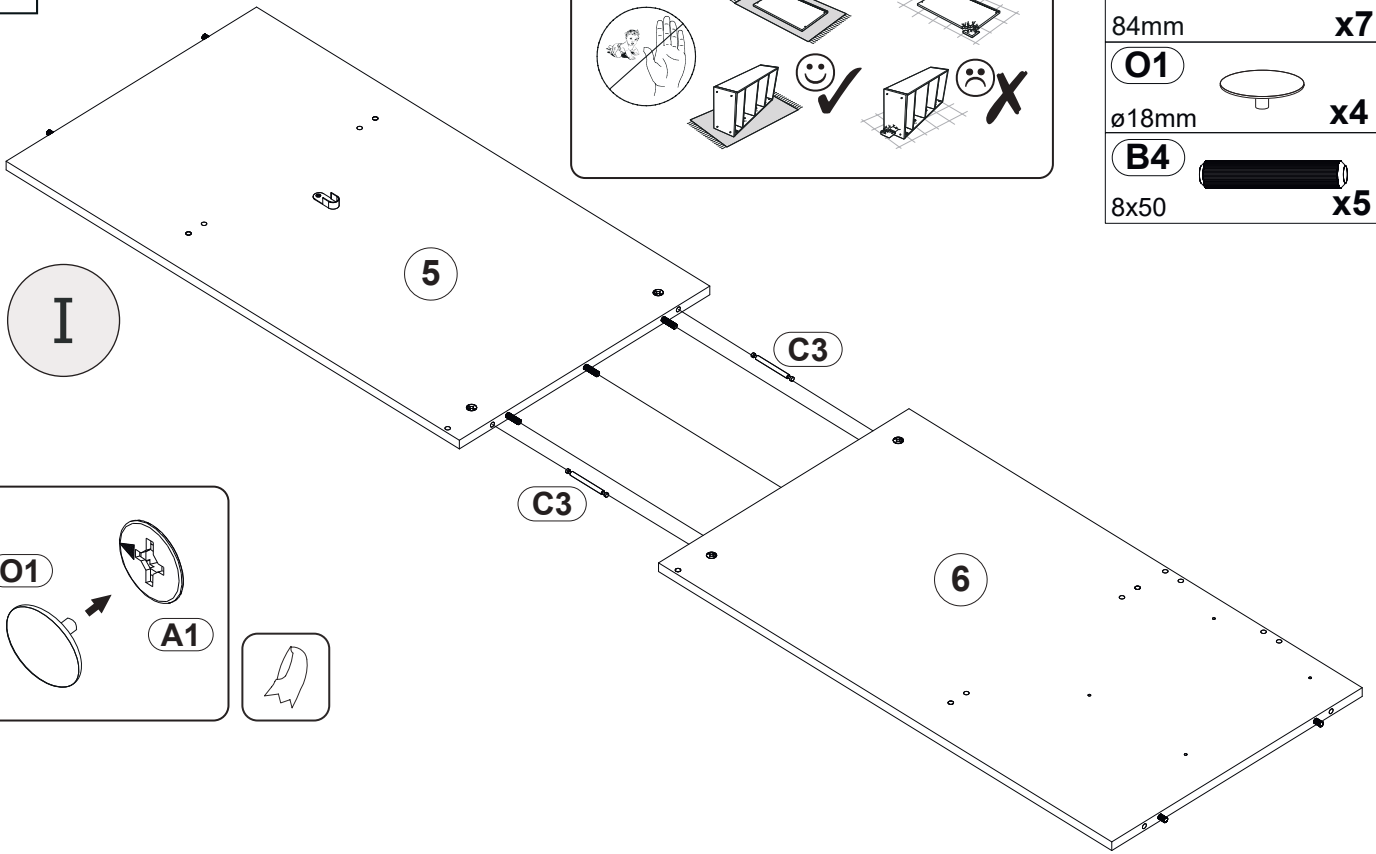

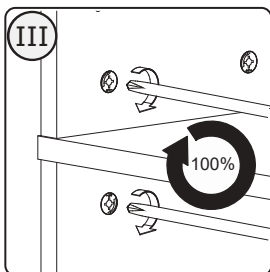
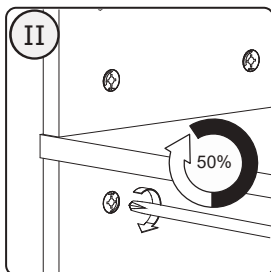
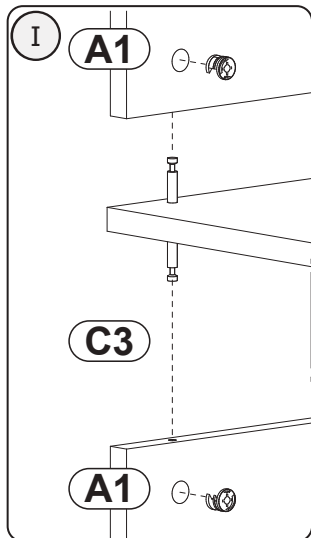
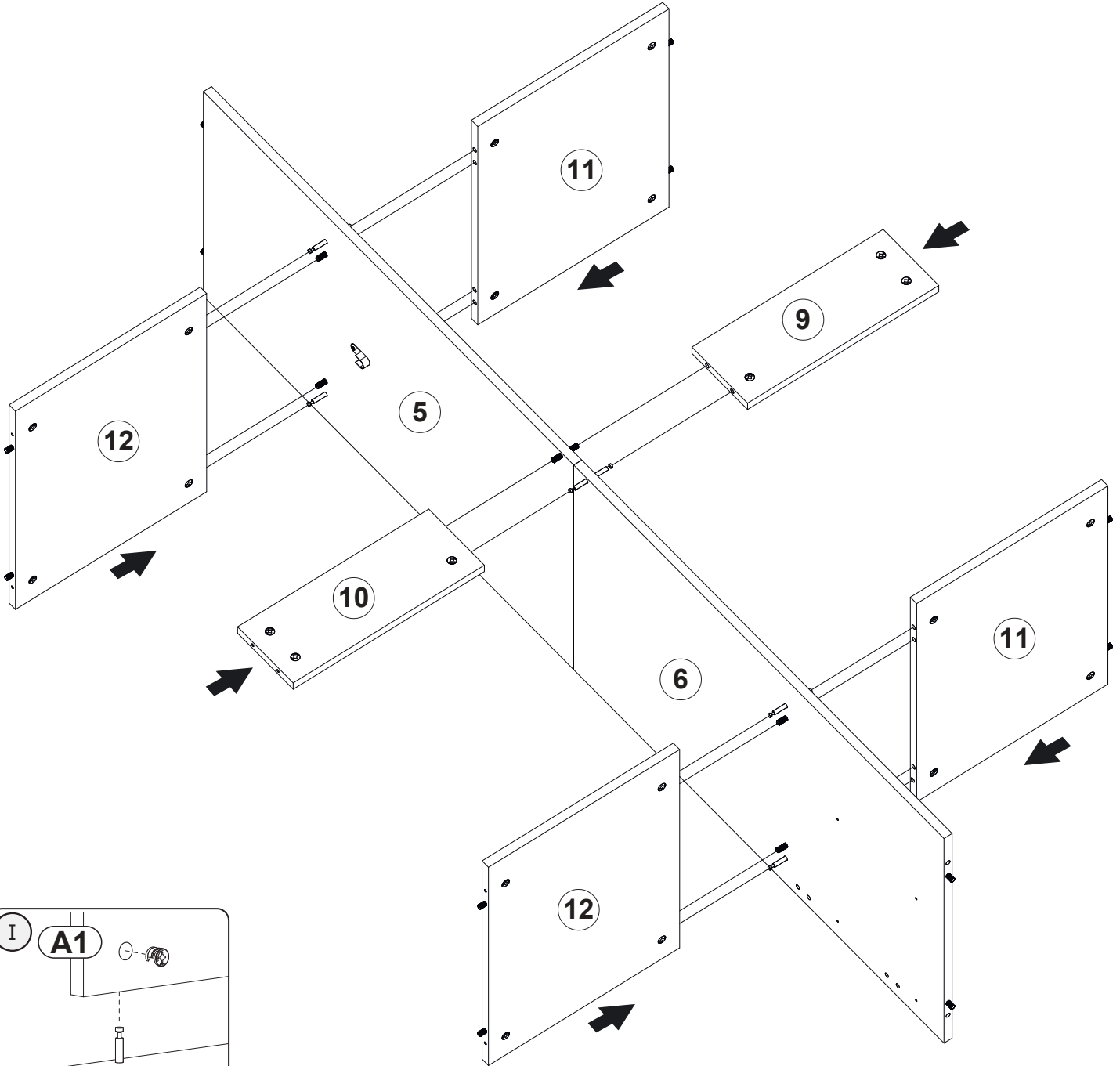
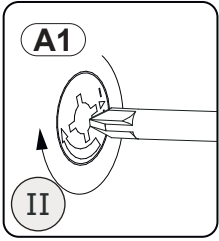
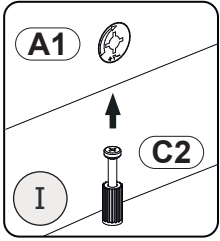
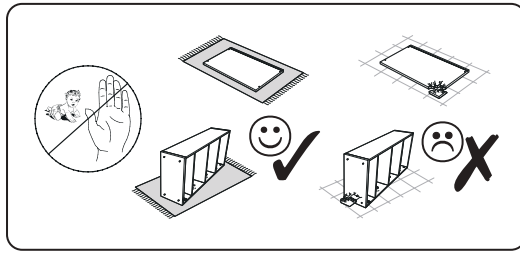

# 9

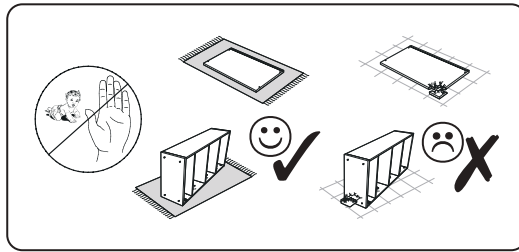
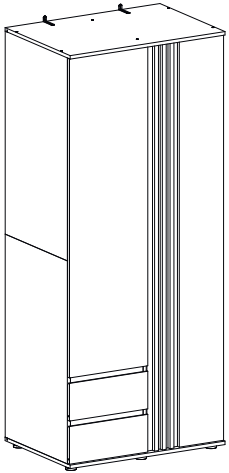

10

L



- O1**  x12
- O2**  x8

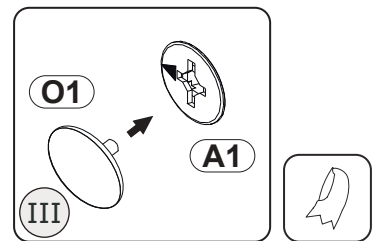
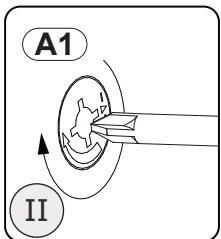
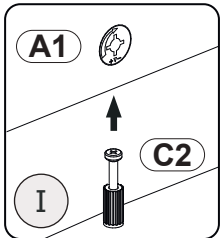
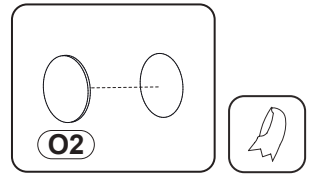
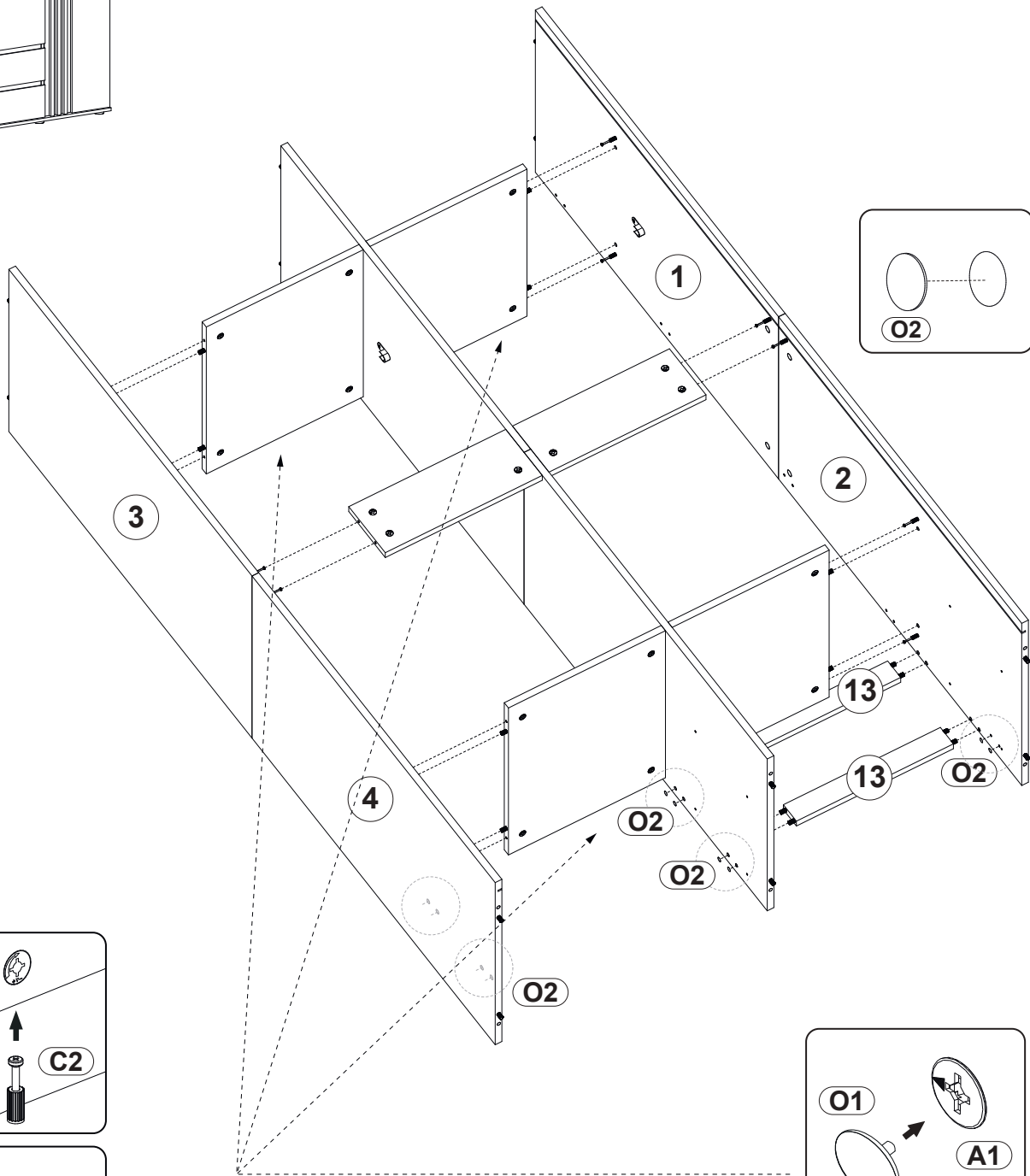

# 11

## L

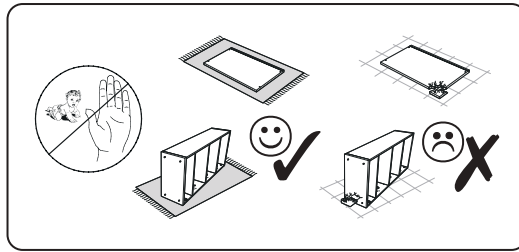
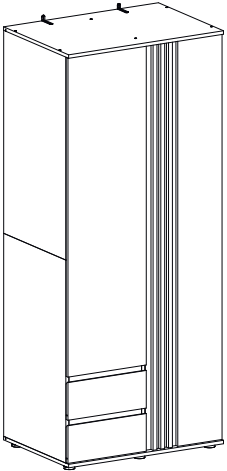

<b>E6</b>		<b>x8</b>
5x13		
<b>L4</b>		<b>x2</b>
400mm		
<b>O2</b>		<b>x8</b>
ø12mm		

### I

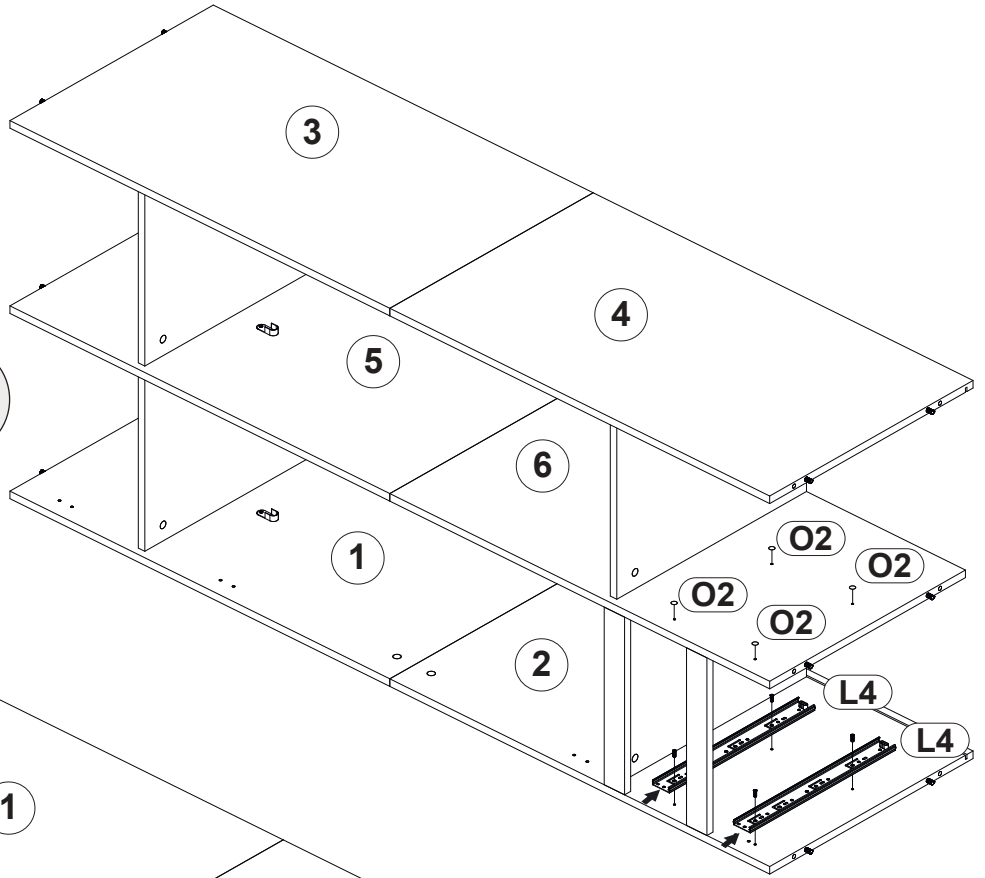

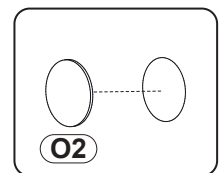
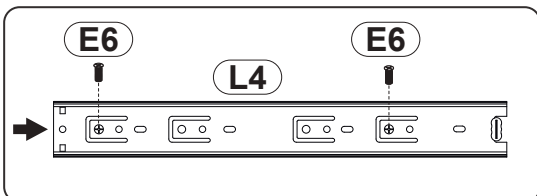
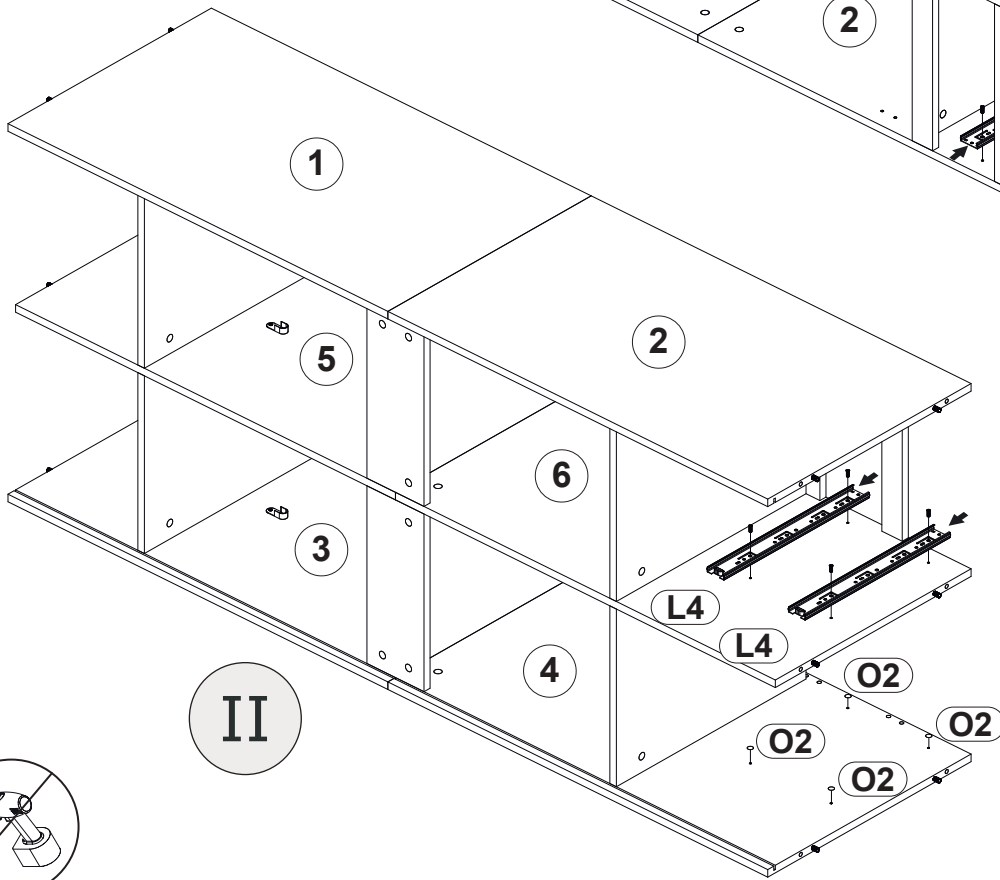

### II

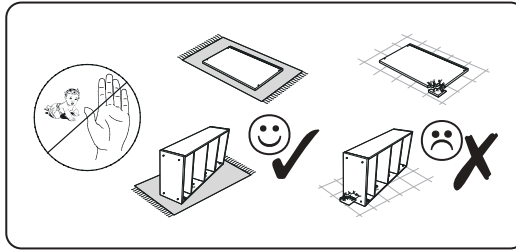
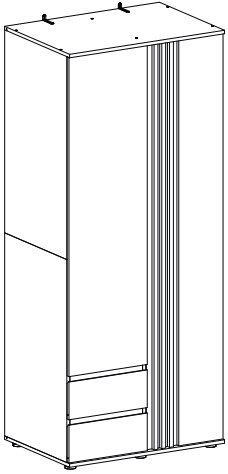

12

L

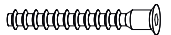

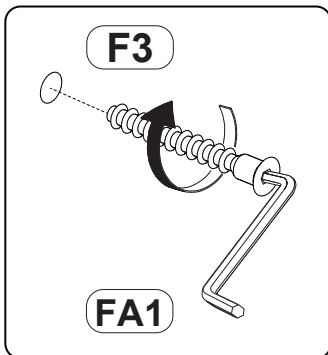
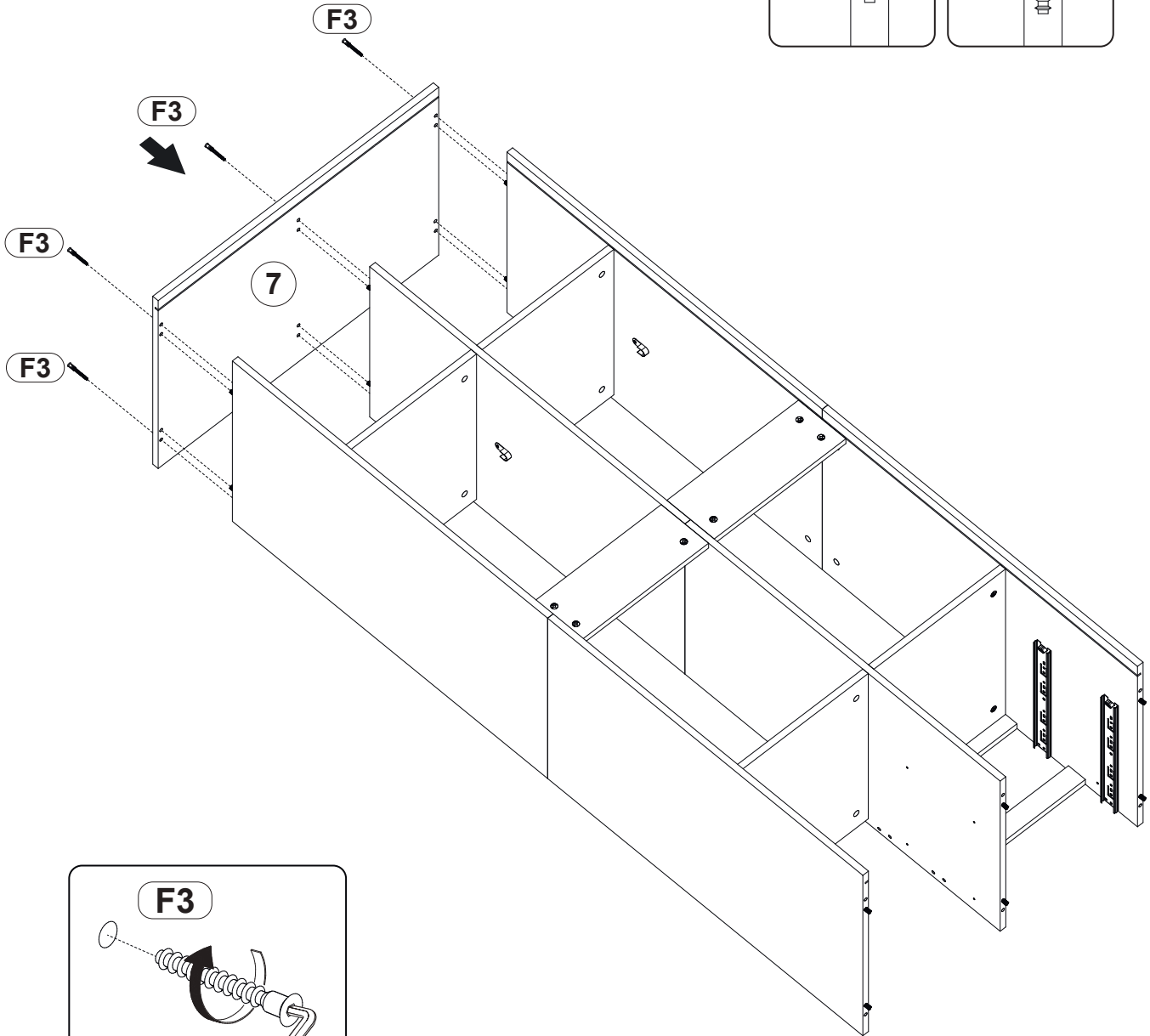
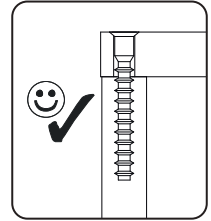
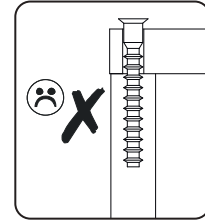

<b>F3</b>		<b>x6</b>
6,3x50		
<b>FA1</b>		<b>x1</b>
4mm		

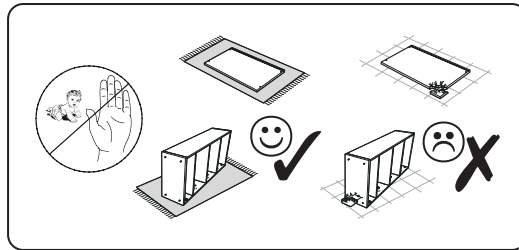
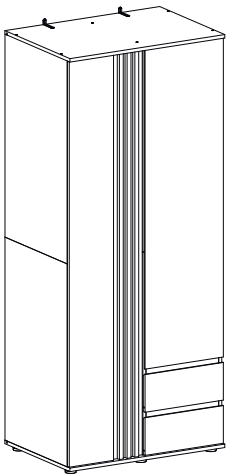

13

R



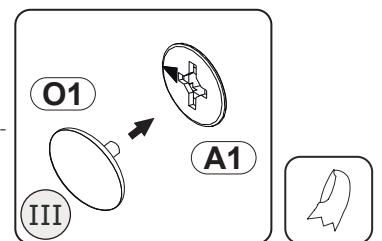
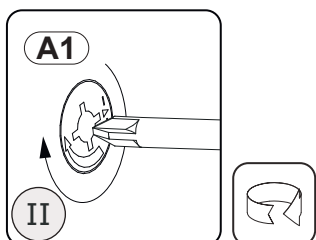
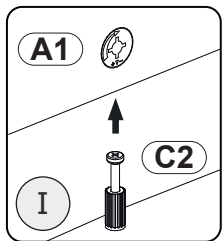
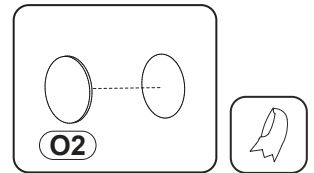
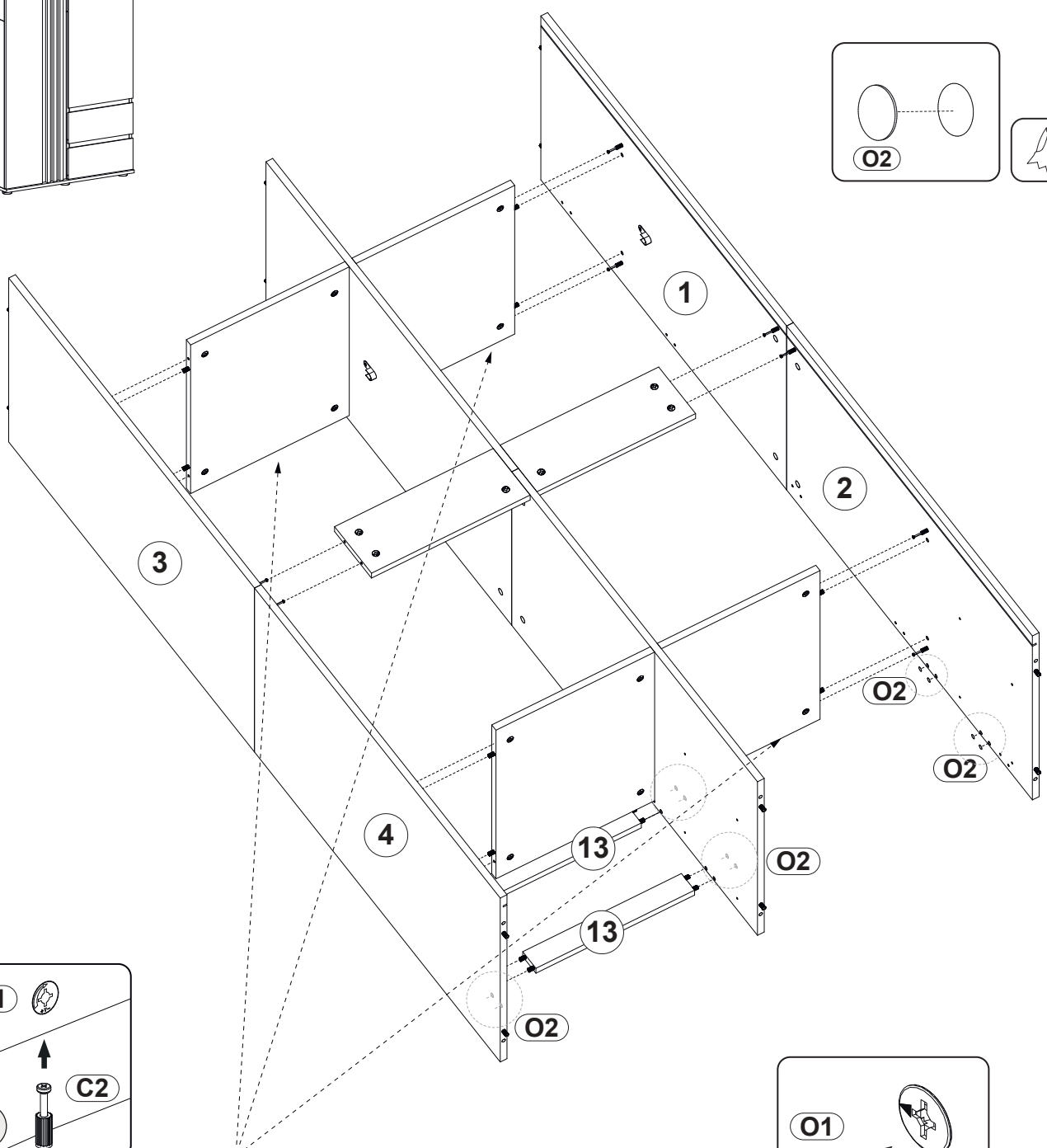

- O1**  **x12**  
ø18mm
- O2**  **x8**  
ø12mm

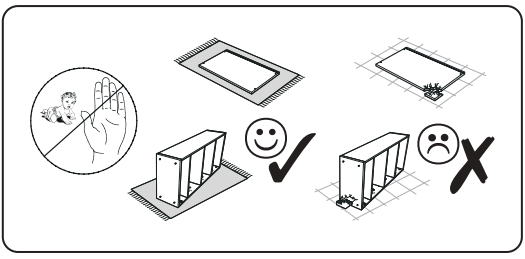
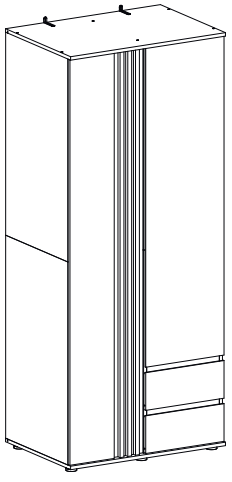

# 14 R

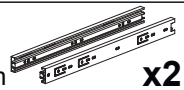

- E6**  **x8**  
5x13
- L4**  **x2**  
400mm
- O2**  **x8**  
ø12mm

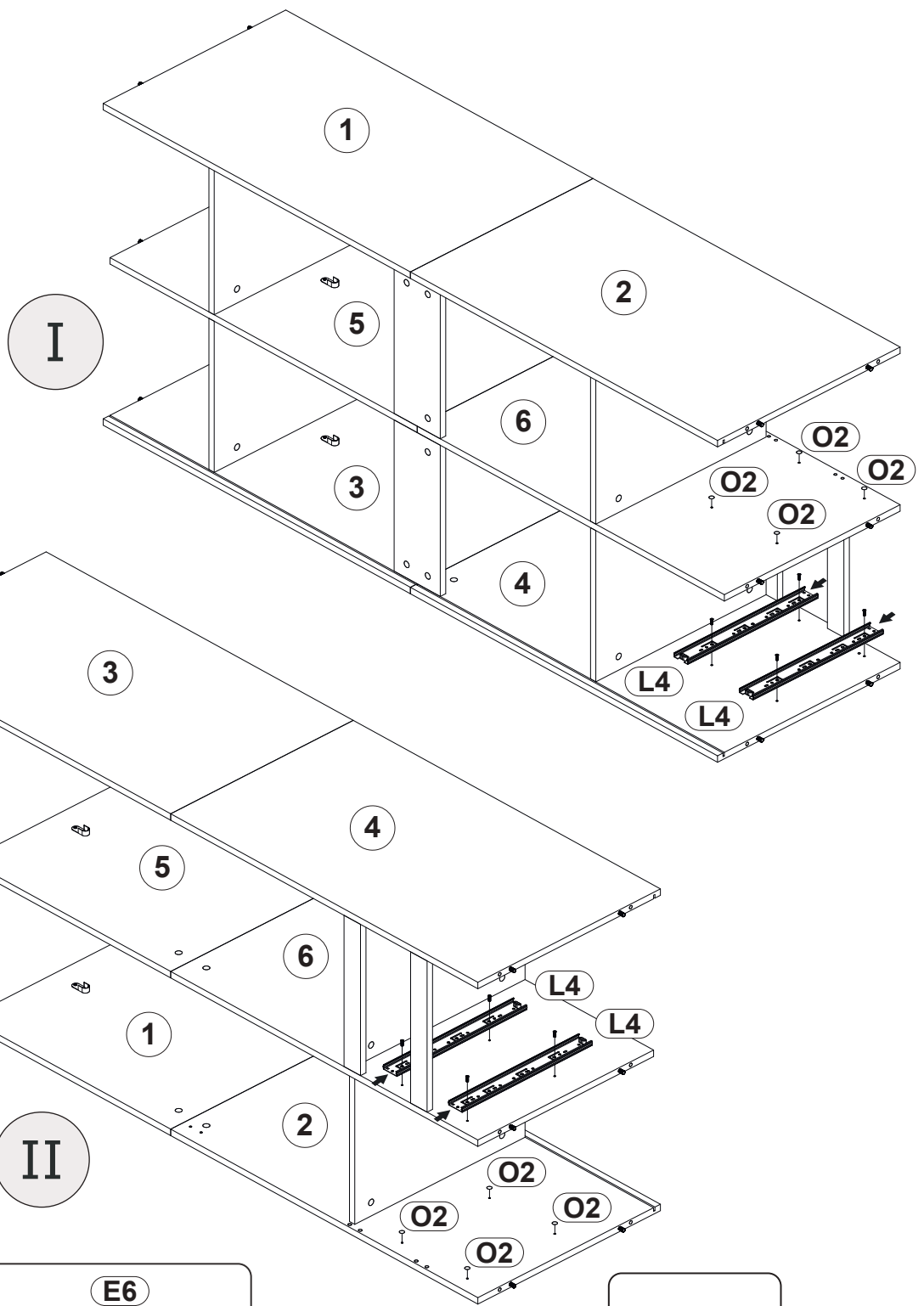

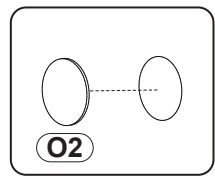
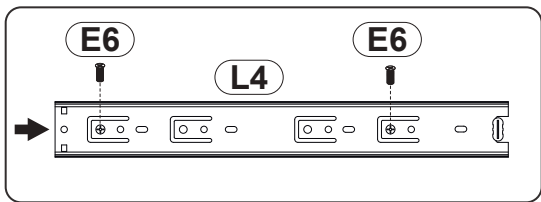

**II**

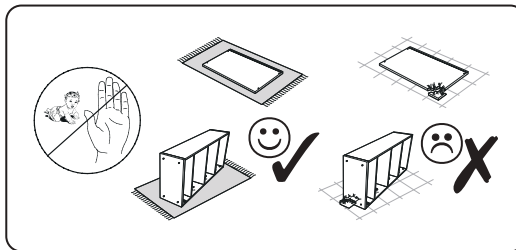
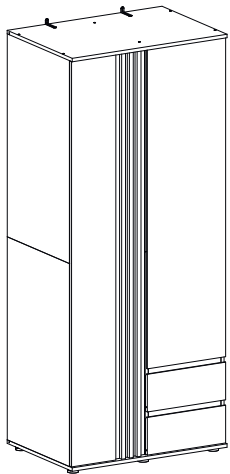

15

R

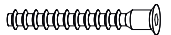

<b>F3</b>		<b>x6</b>
6,3x50		
<b>FA1</b>		<b>x1</b>
4mm		

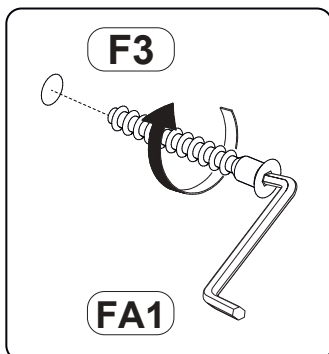
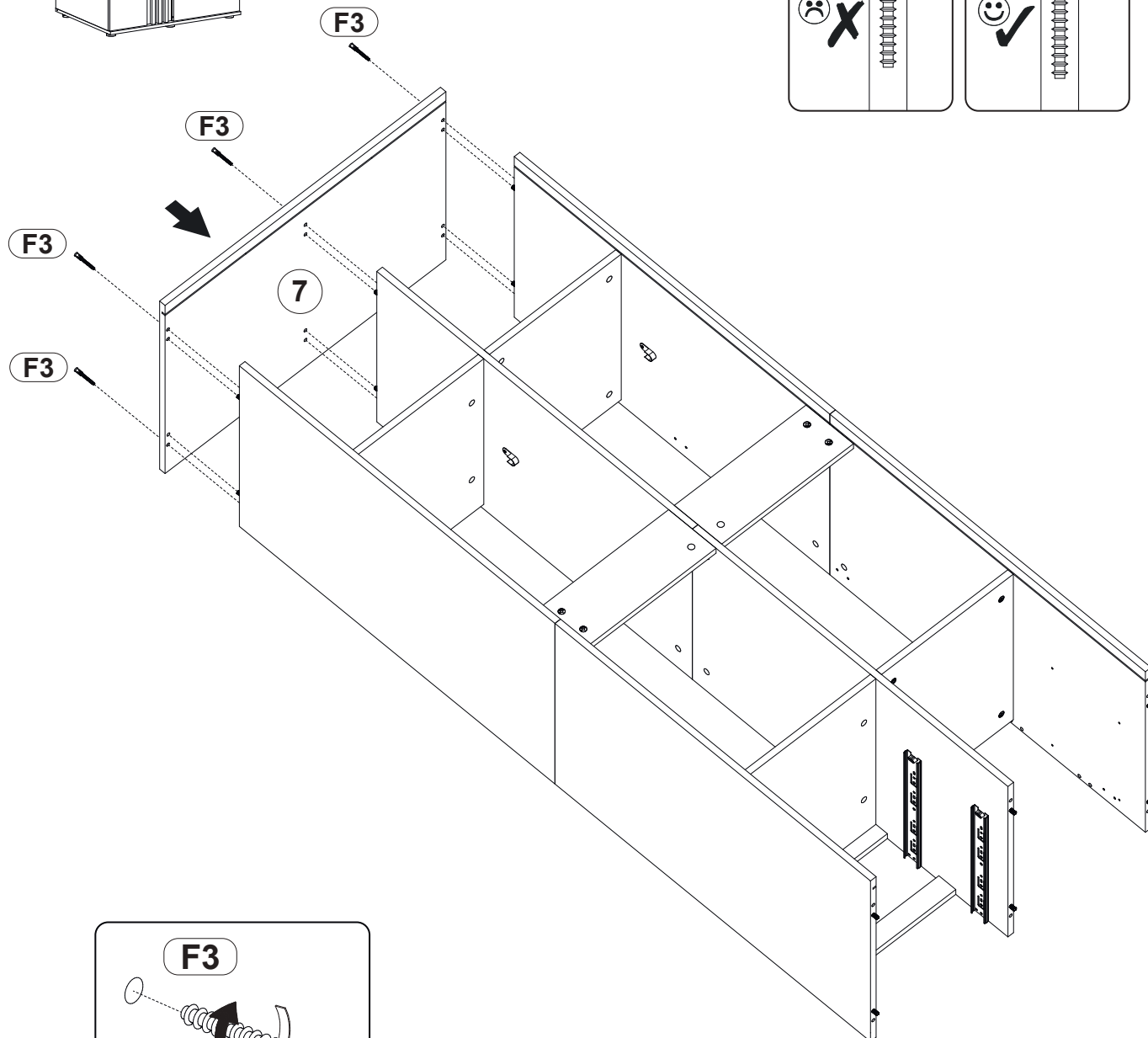
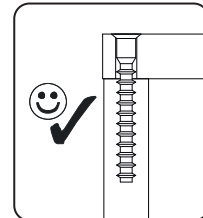
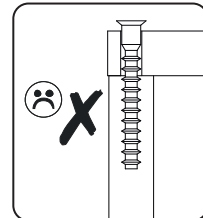

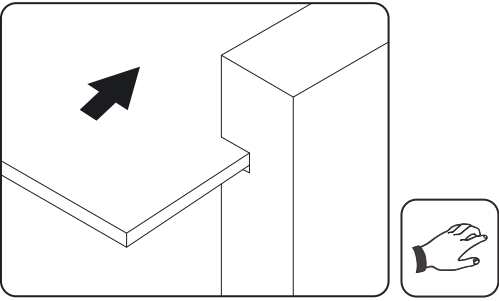
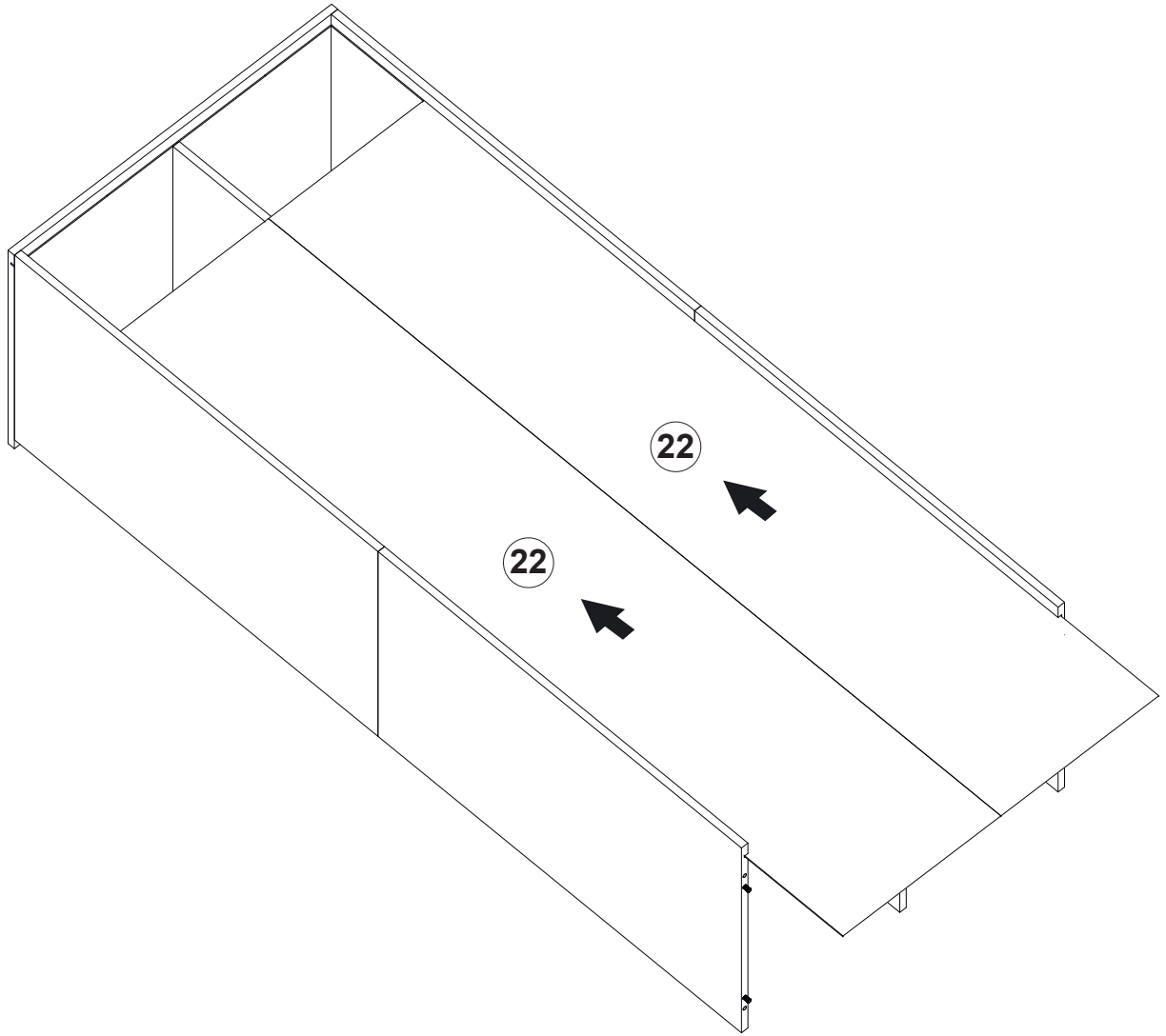
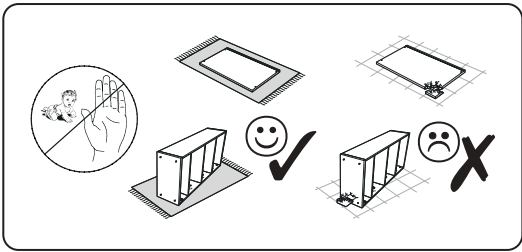

16

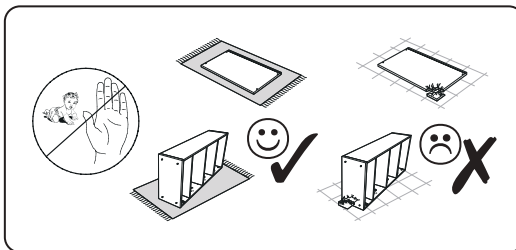

17

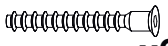

<b>F3</b>		<b>x6</b>
6,3x50		
<b>FA1</b>		<b>x1</b>
4mm		

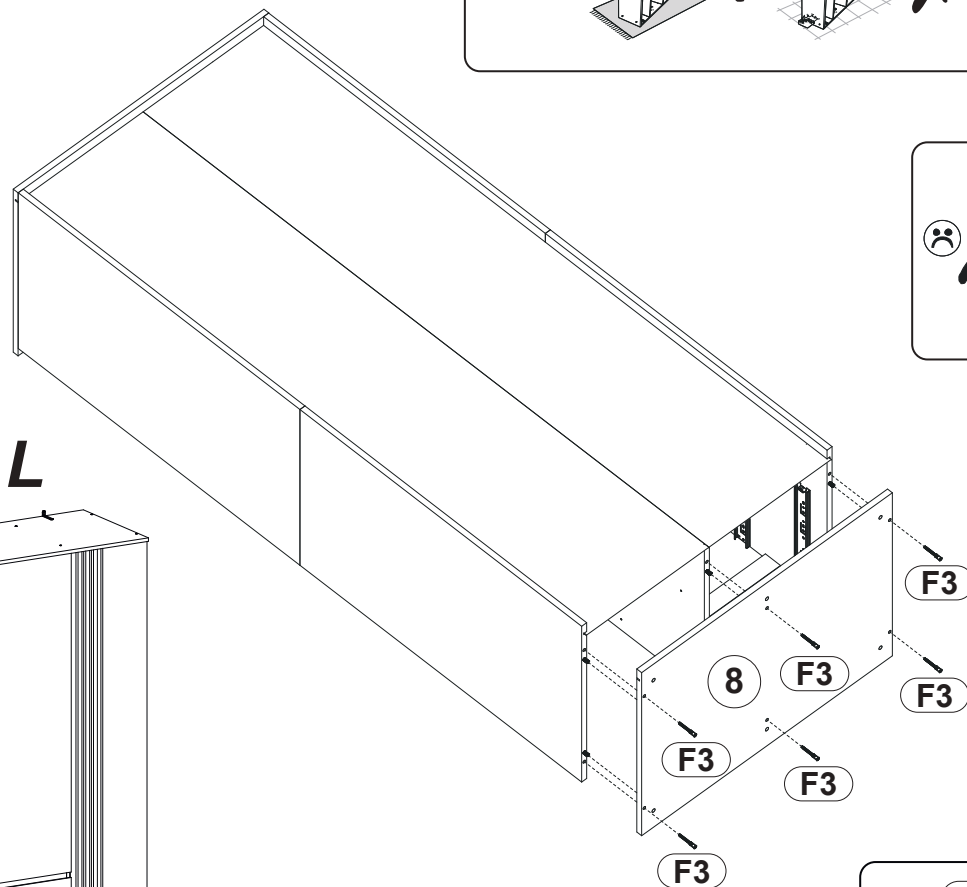
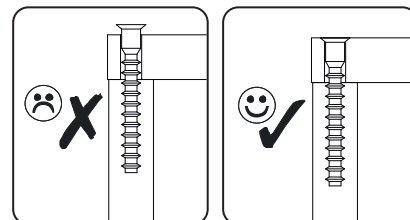

L

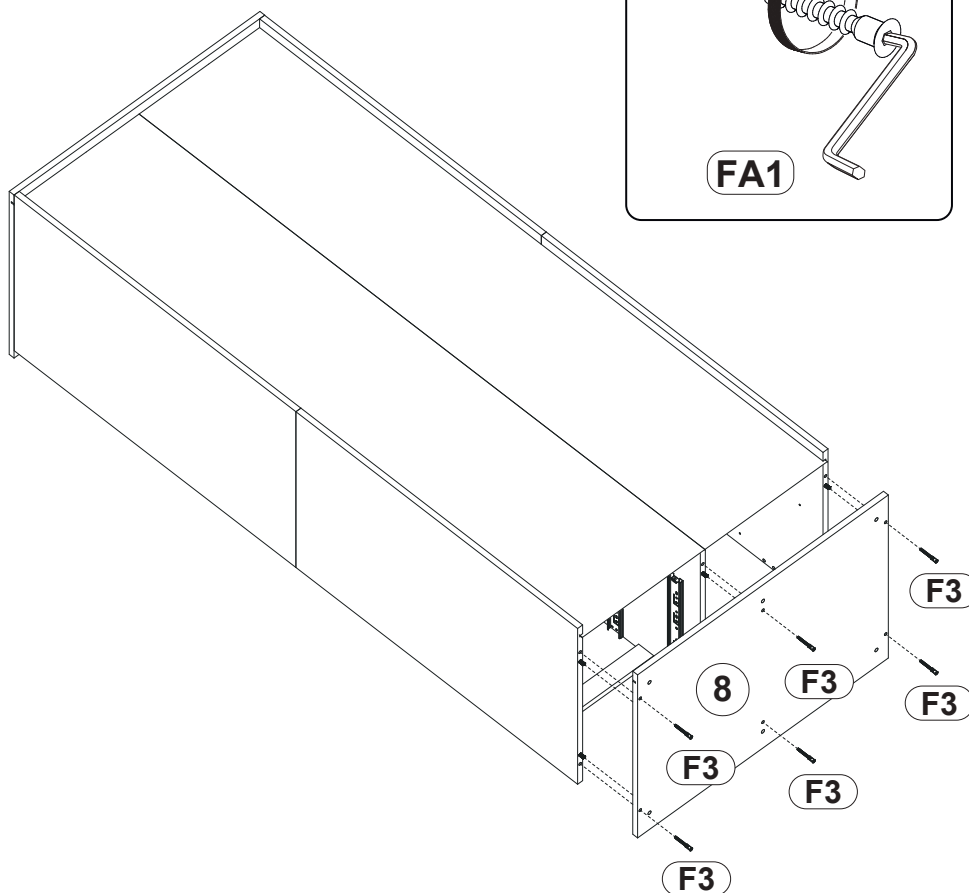
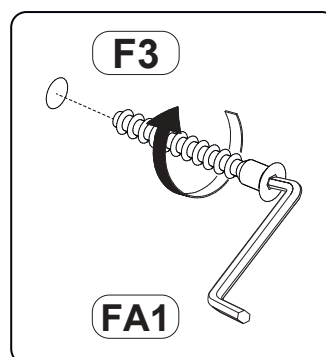
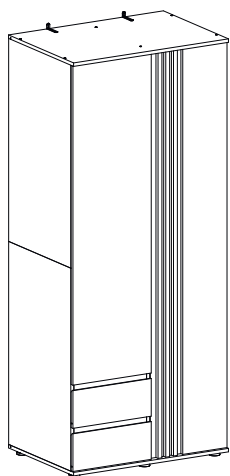



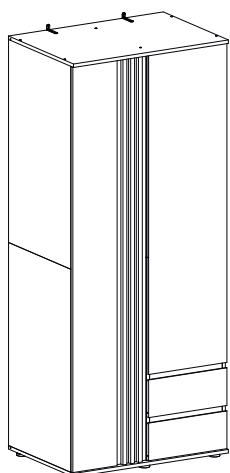

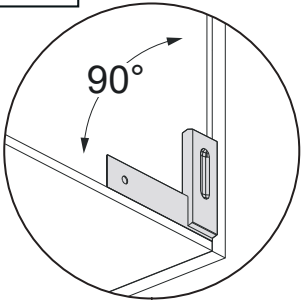
R



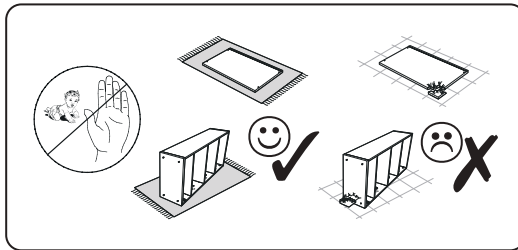

A=B

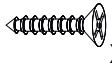

- M1**  **x18**
- DA20**  **x8**
- P17**  **x6**
- S4**  **x10**
- D11**  **x10**

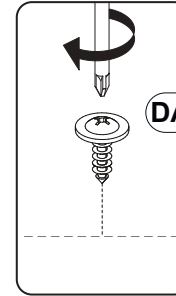

DA20

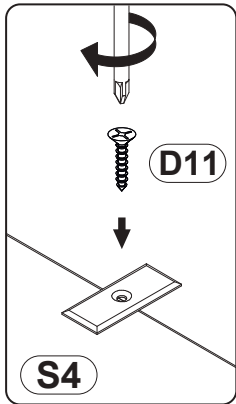
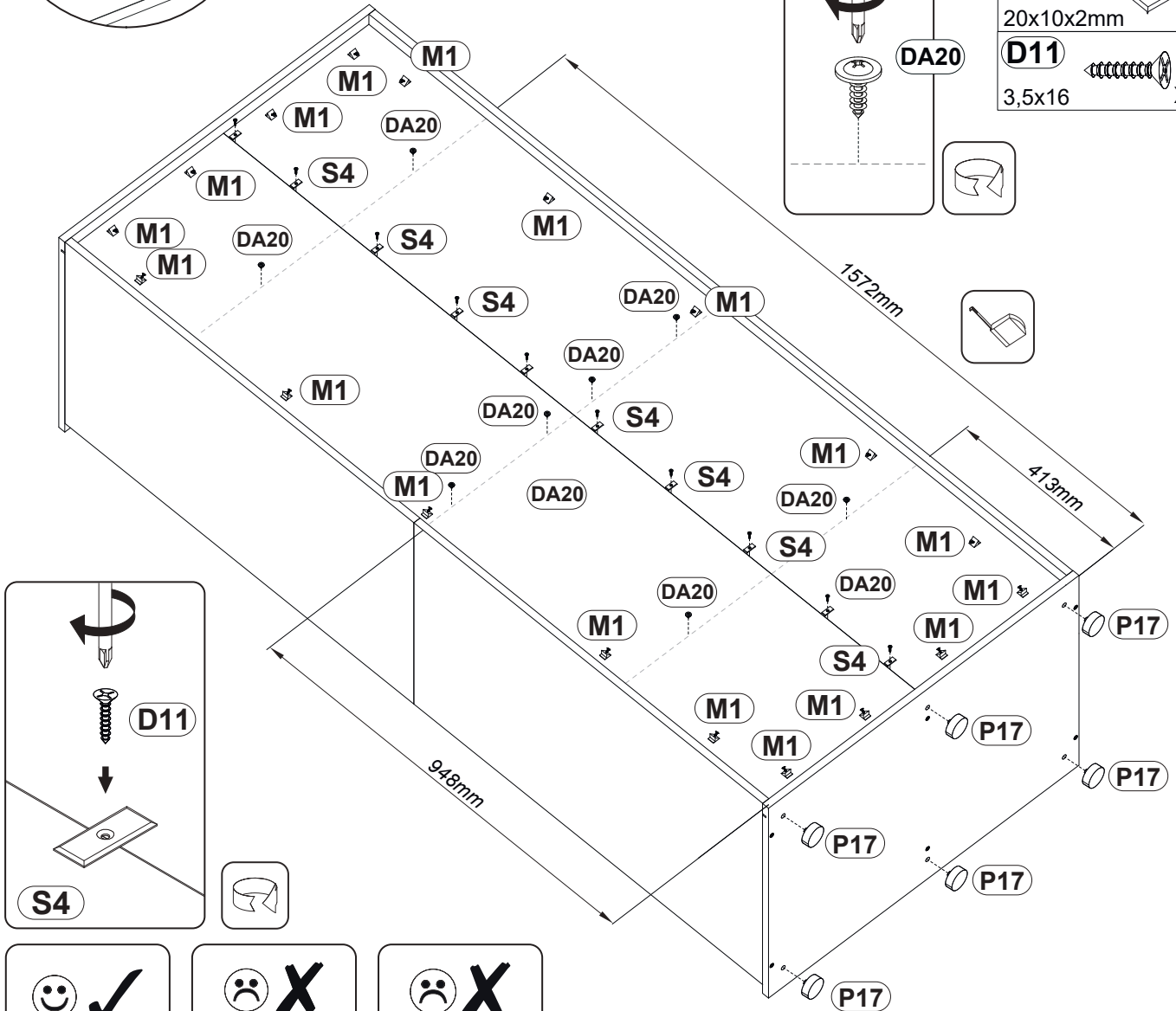

D11

S4

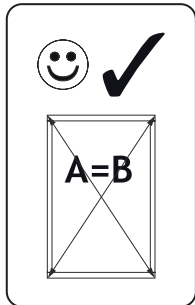

✓

A=B

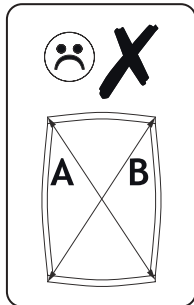

✗

A B

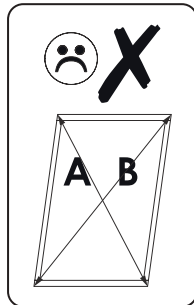

✗

A B

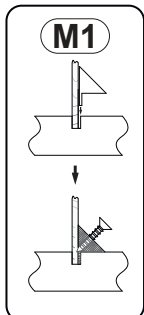

M1

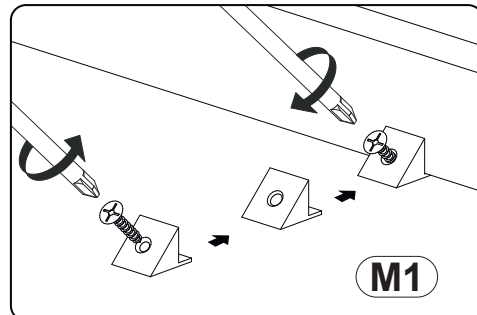

M1

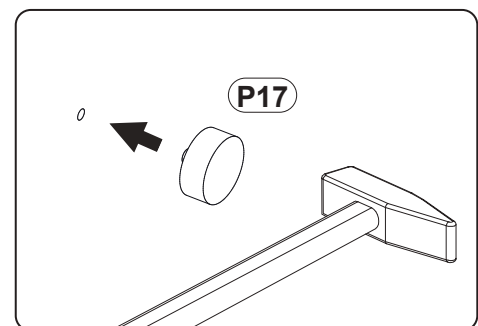



P17

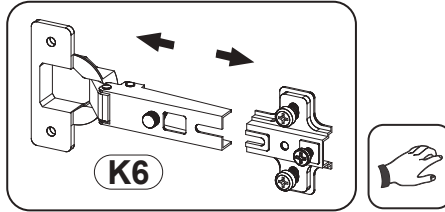
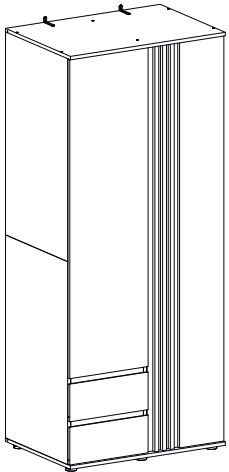

19

L

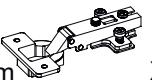

<b>K6</b>		<b>x7</b>
ø35mm		
<b>O2</b>		<b>x2</b>
ø12mm		

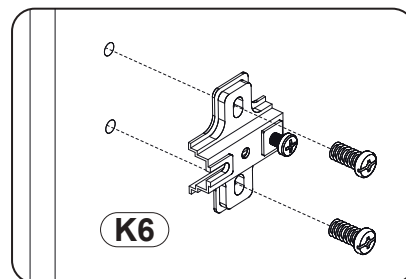
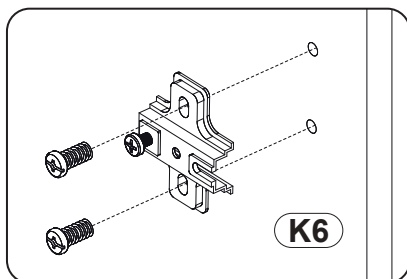
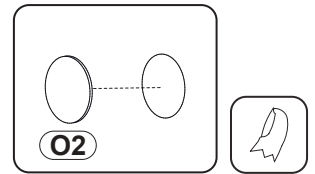
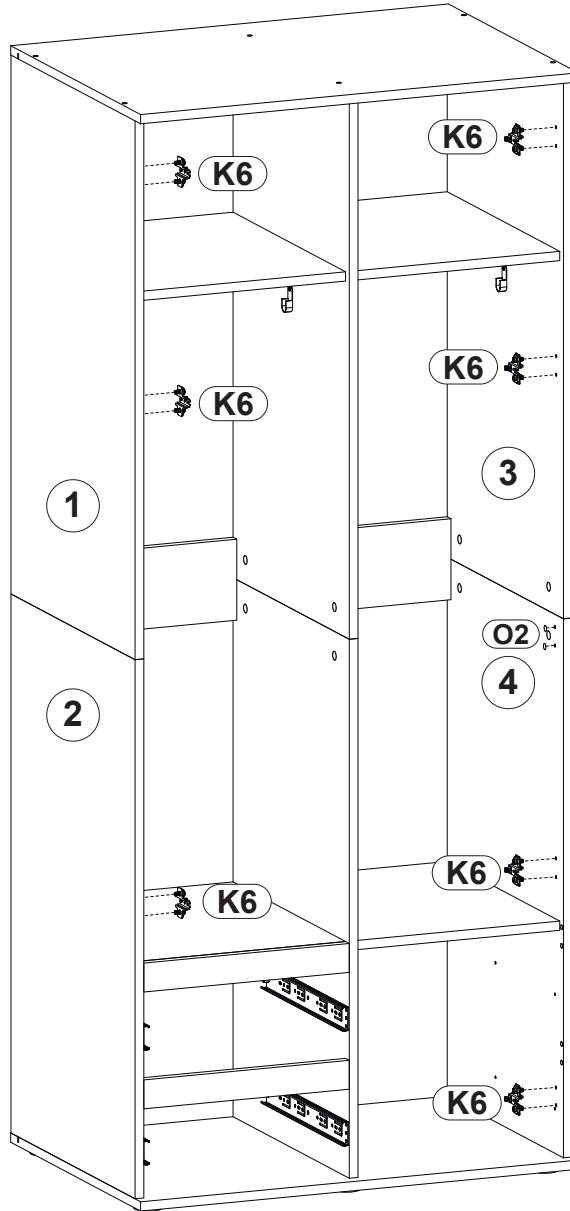

20

L

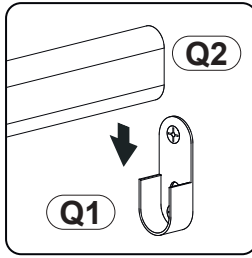
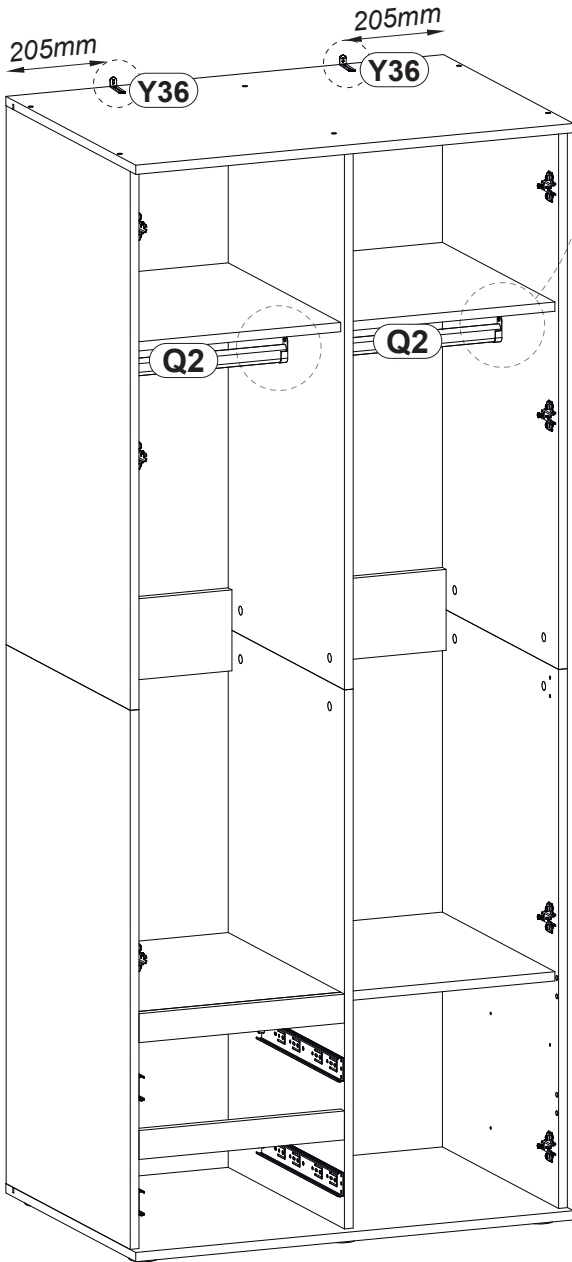
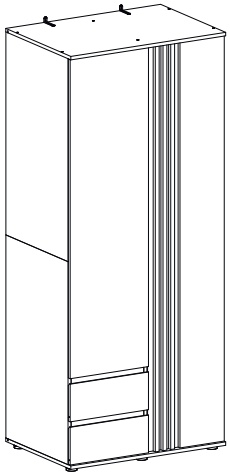

<b>Q2</b>		<b>x2</b>
372x23x15mm		
<b>Y36</b>		<b>x2</b>
75x25x15		
<b>D11</b>		<b>x4</b>
3,5x16		

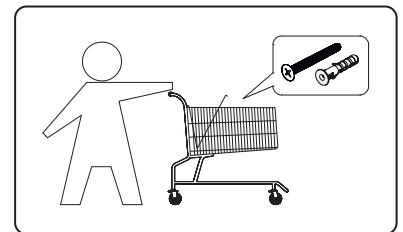
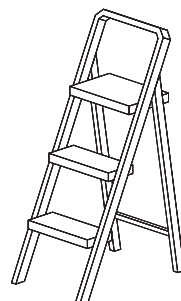
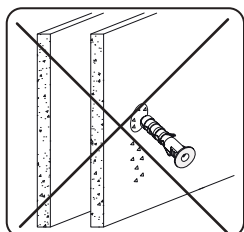
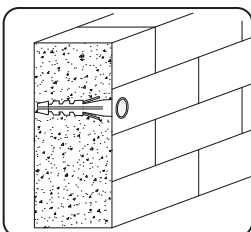
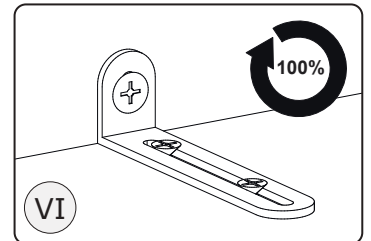
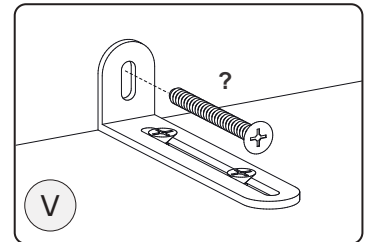
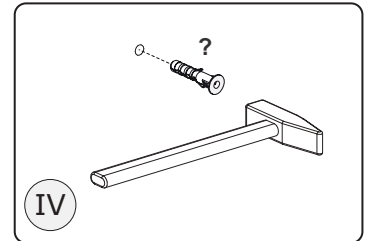
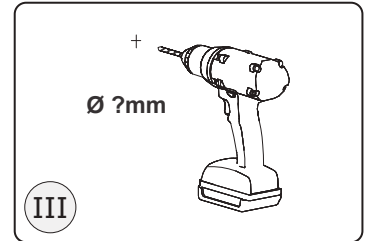
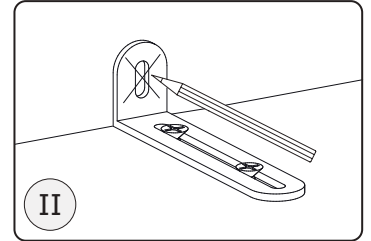
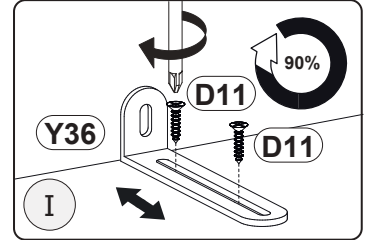

21

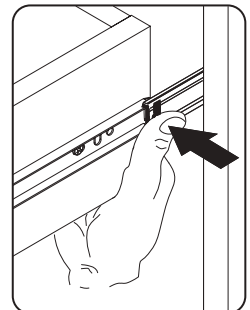
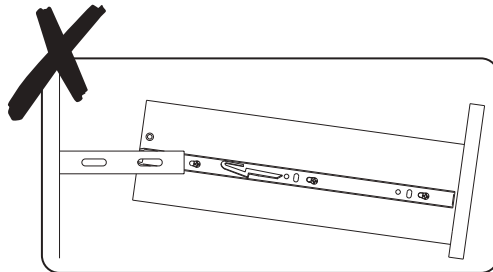
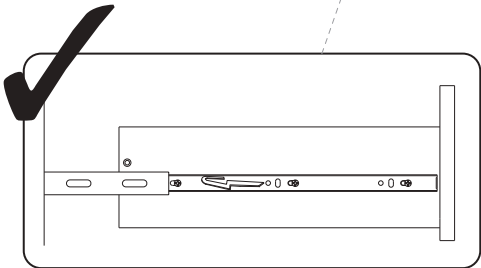
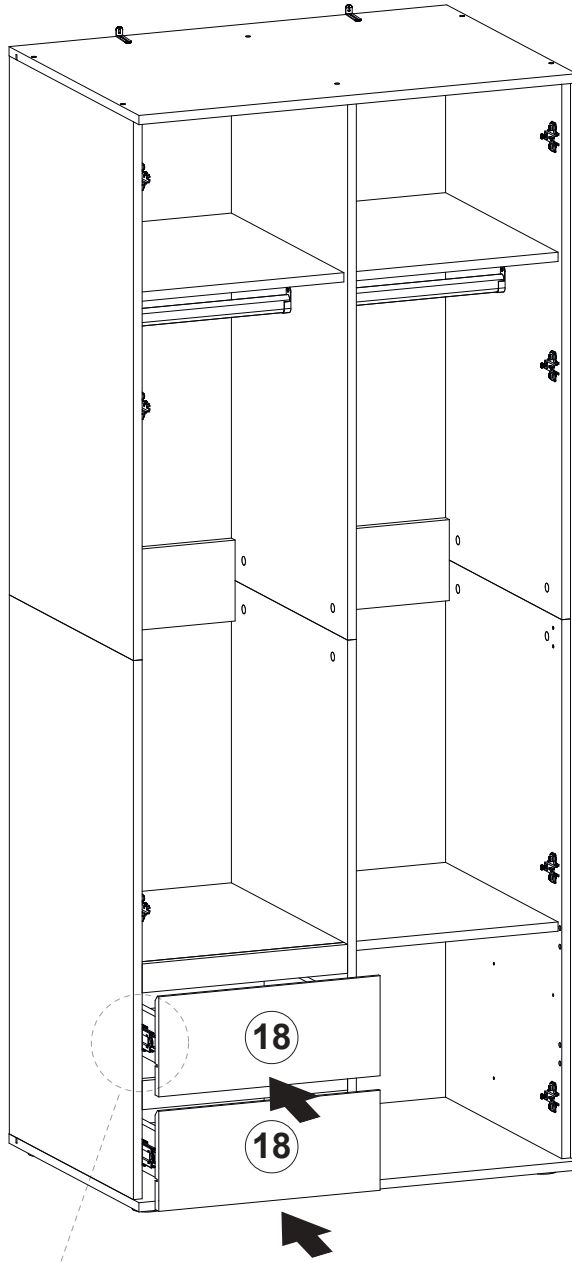
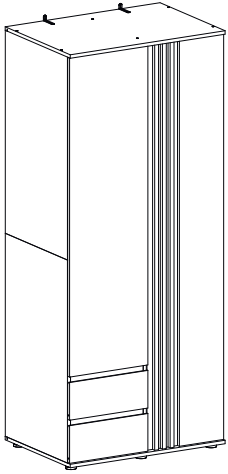

L

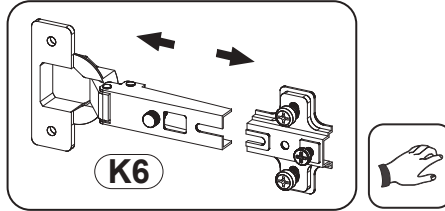
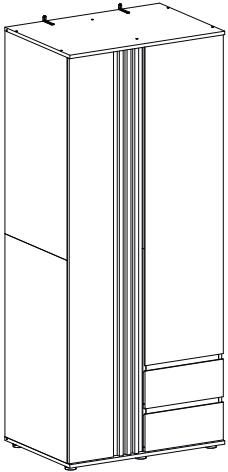

22

R

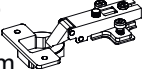

- K6**  
ø35mm  x7
- O2**  
ø12mm  x2

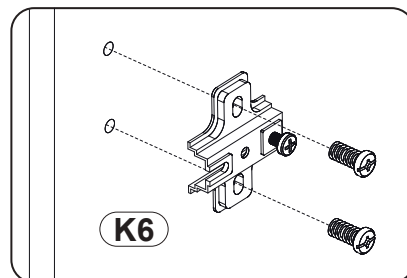
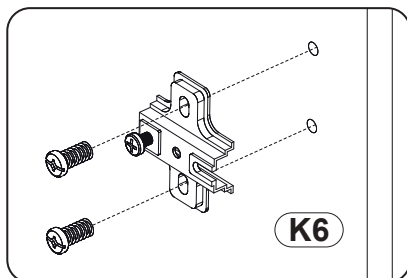
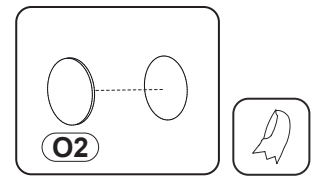
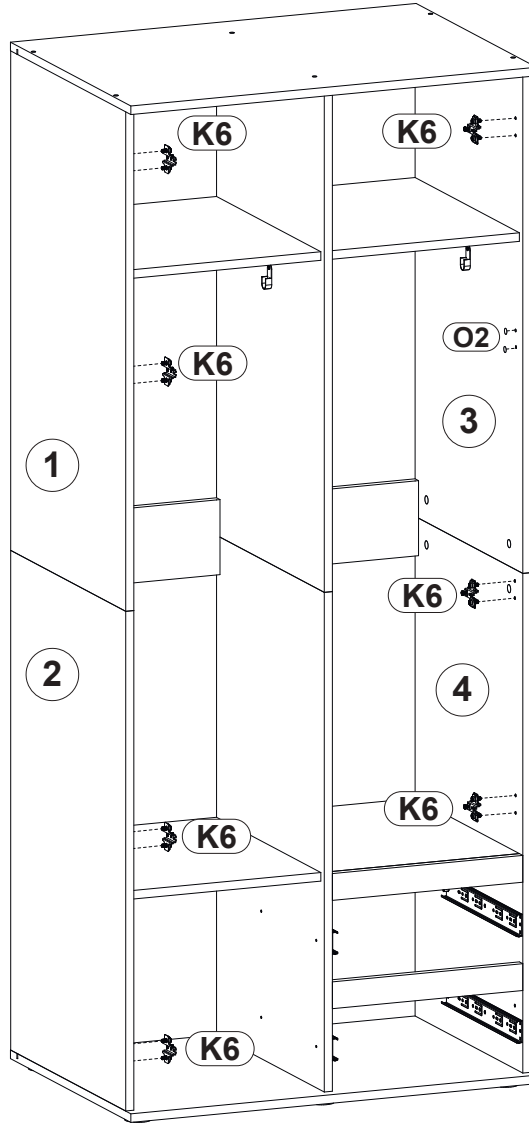

R

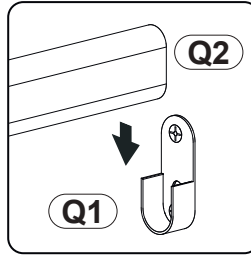
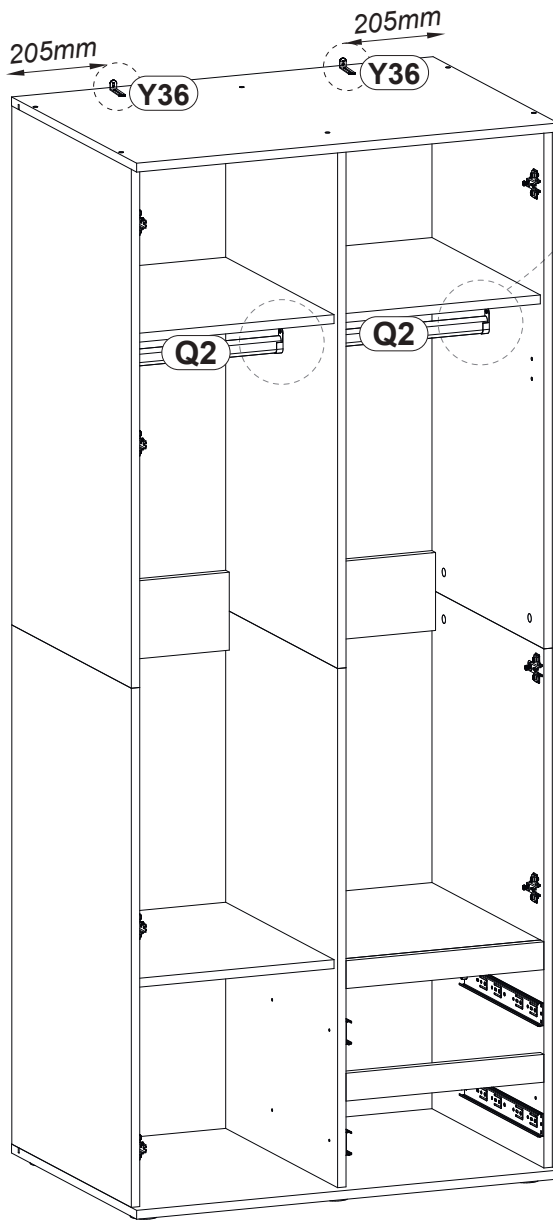
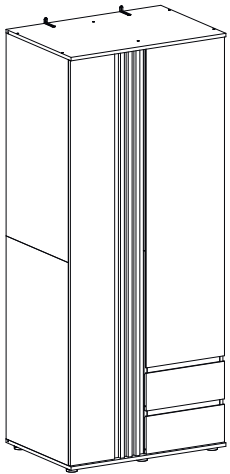

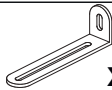
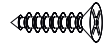
- Q2**  x2  
372x23x15mm
- Y36**  x2  
75x25x15
- D11**  x4  
3,5x16

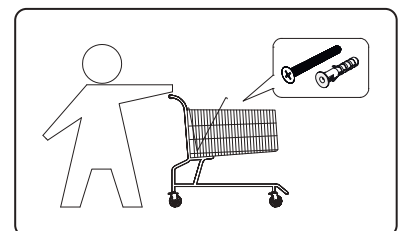
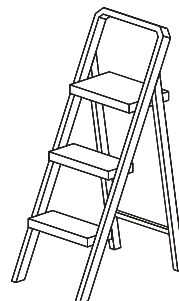
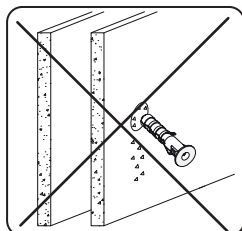
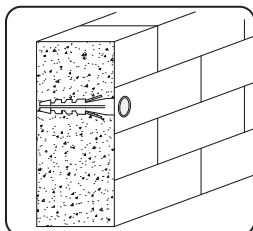
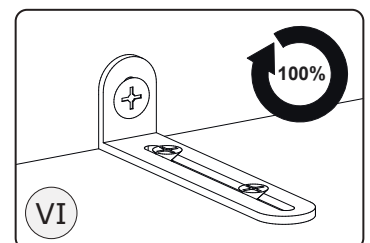
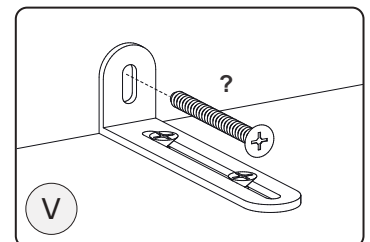
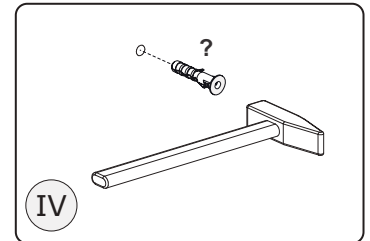
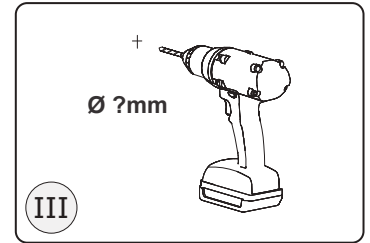
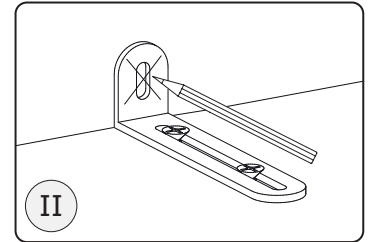
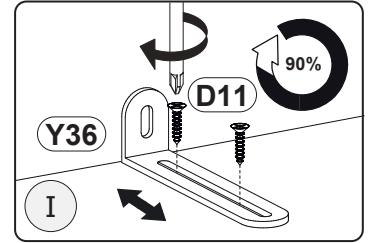

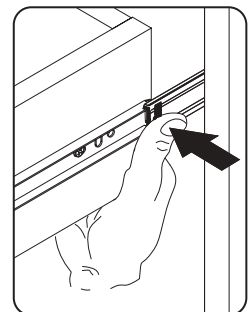
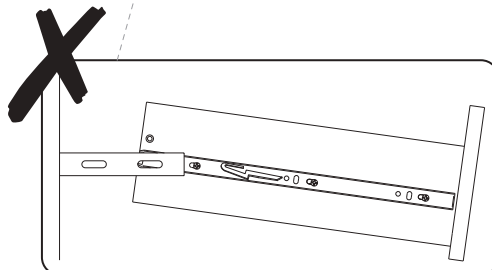
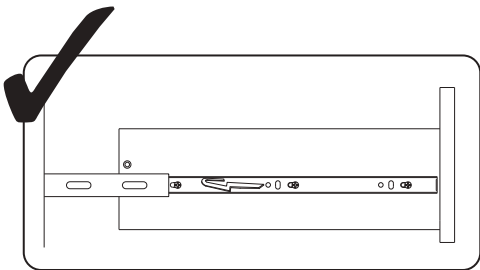
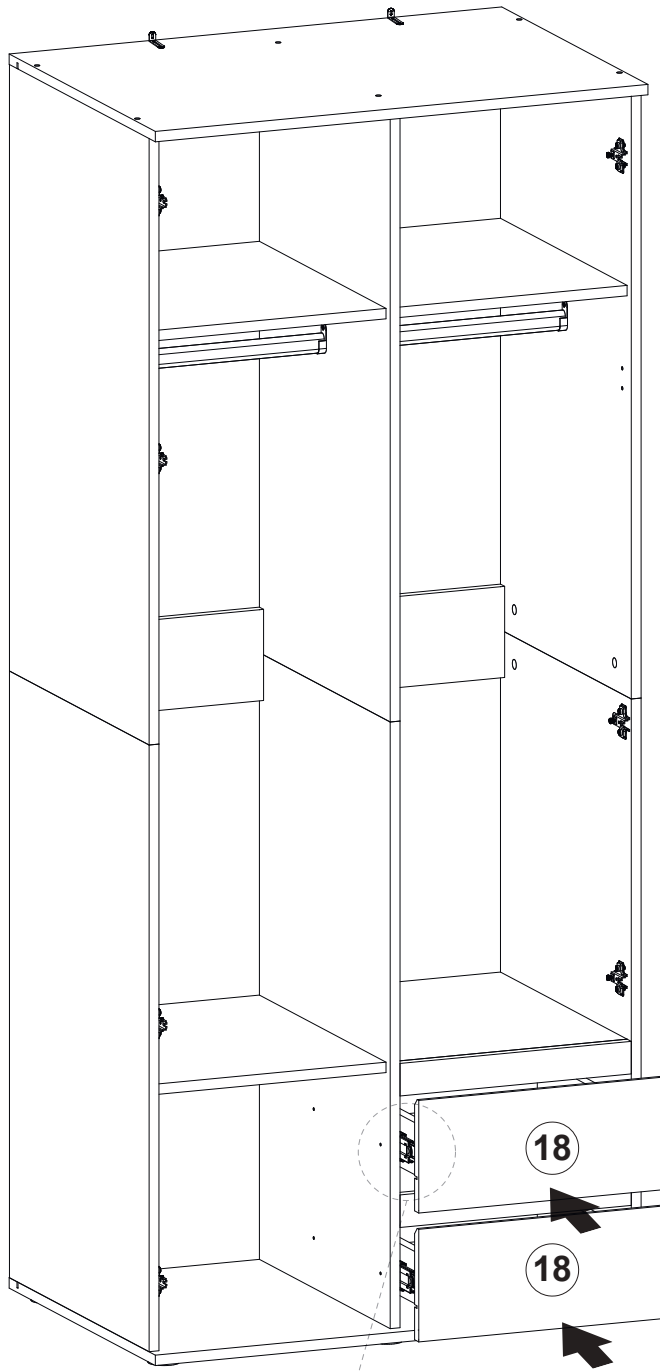
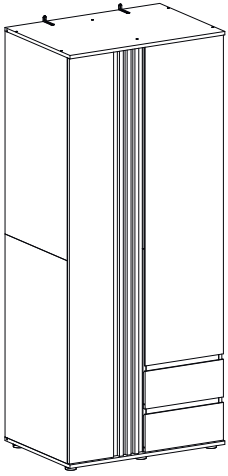

24

R

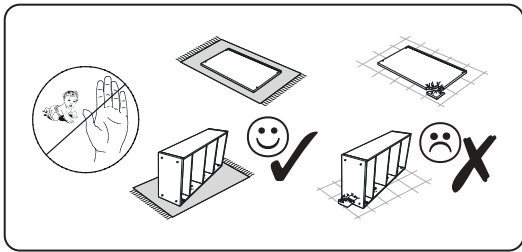



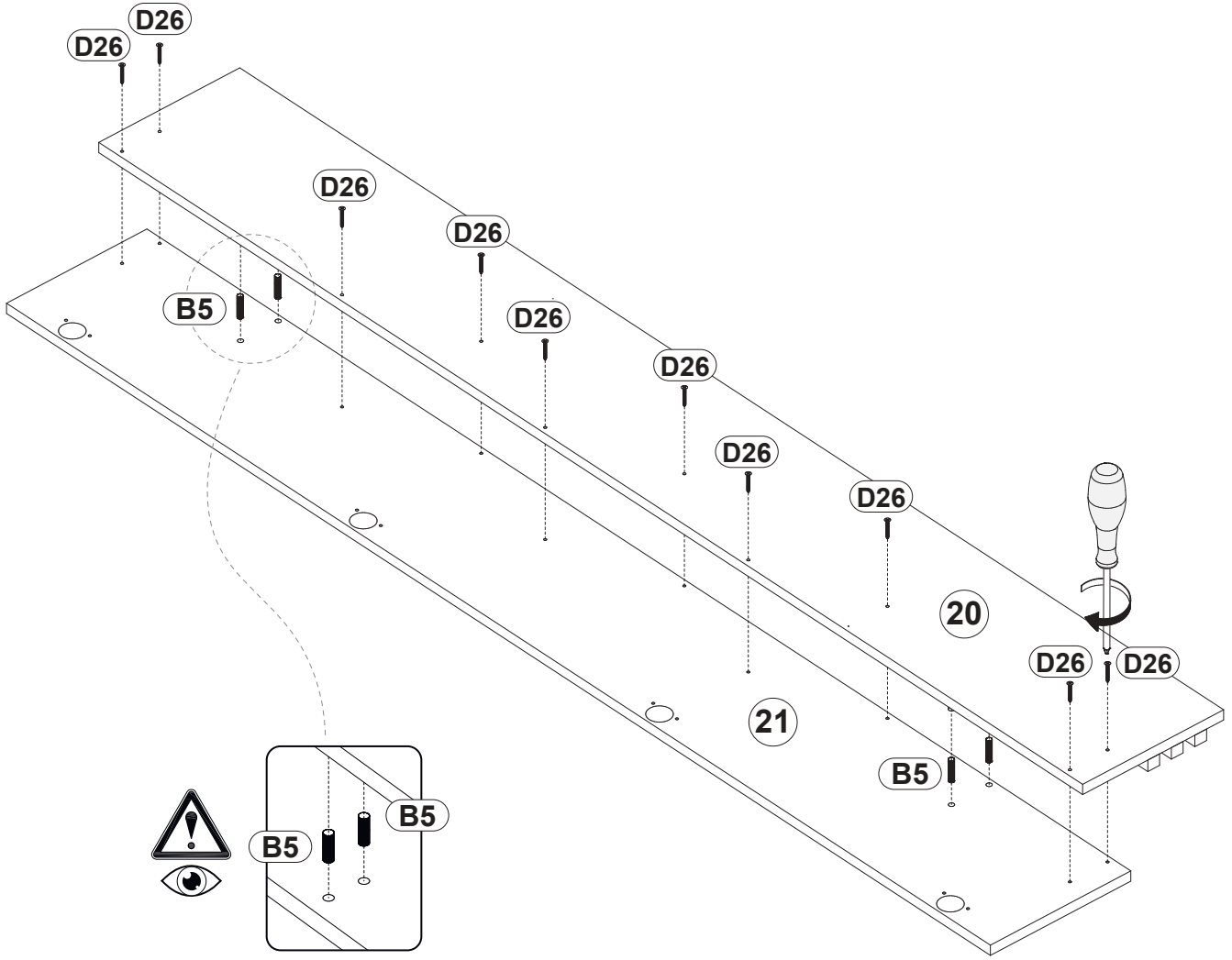

- B5**  **x4**
- D26**  **x10**
- 8x20
- 4x30

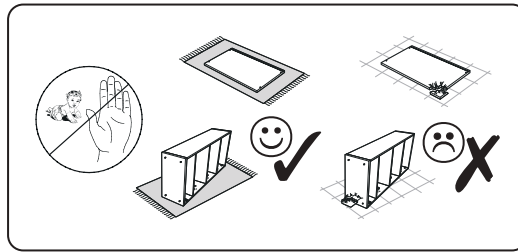
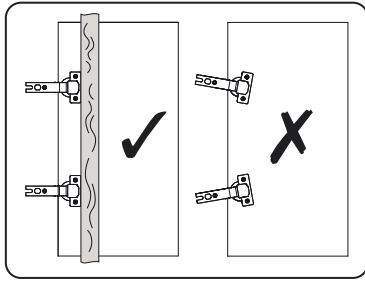

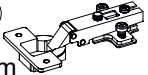



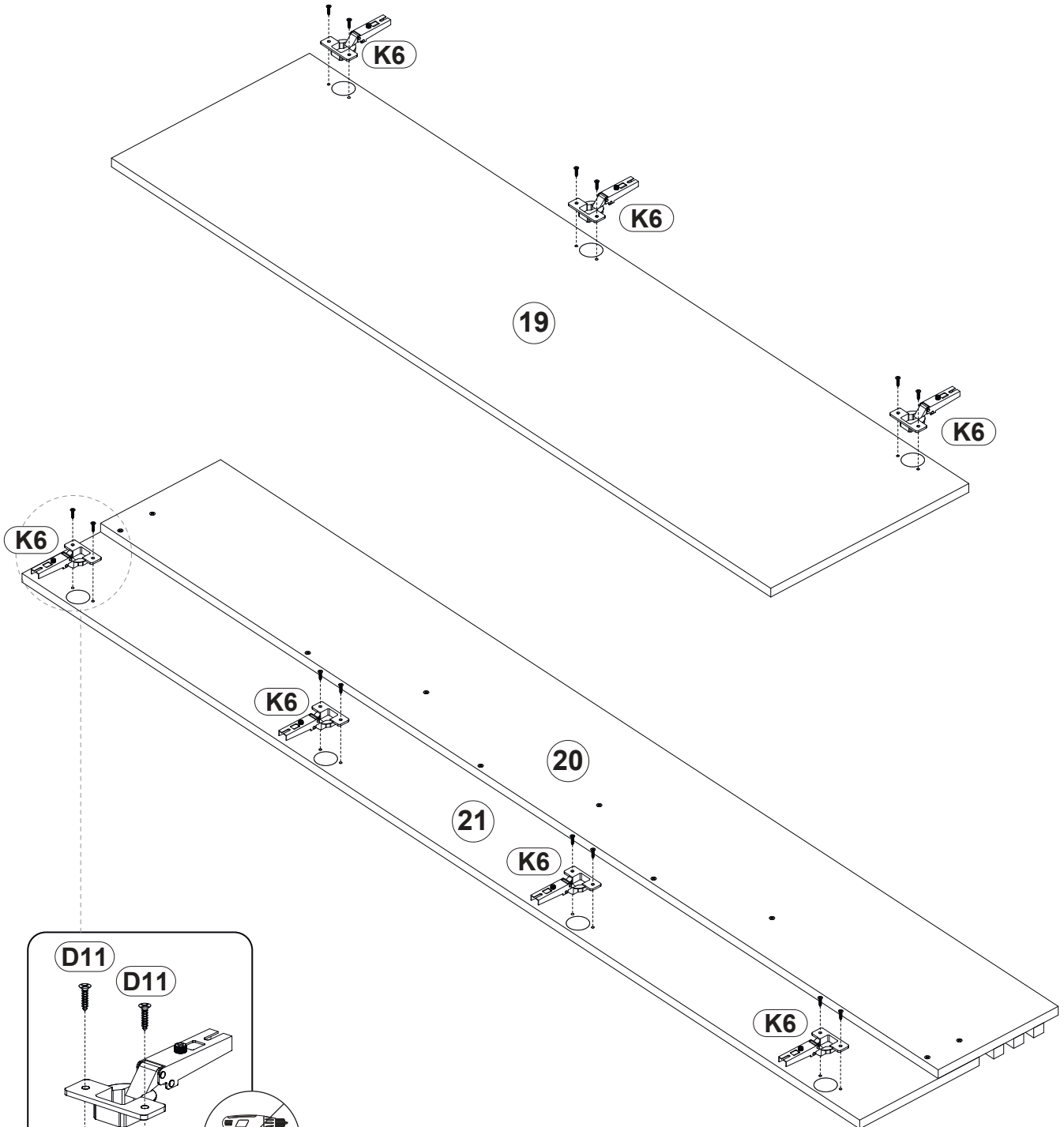

**K6**  **x7**  
ø35mm

**D11**  **x14**  
3,5x16

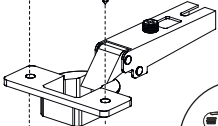

**D11**  **D11** 

**K6** 





27

L

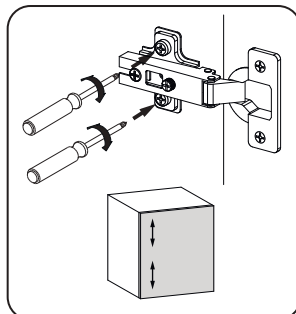
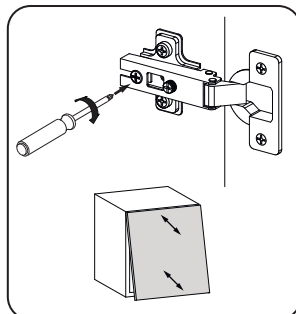
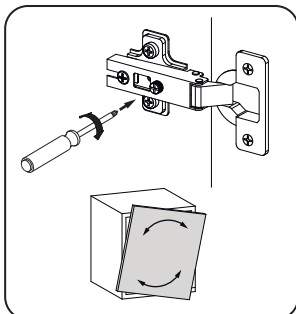
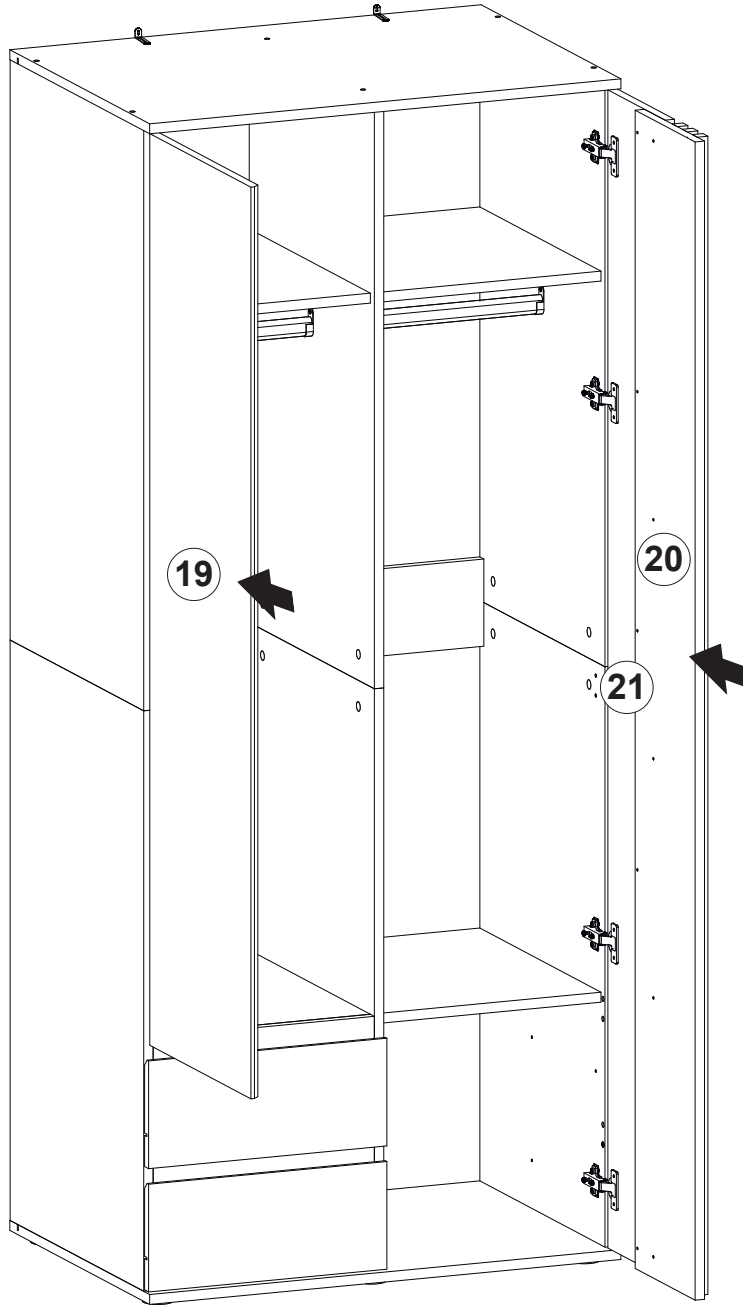
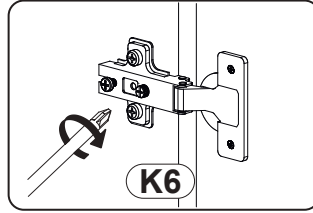
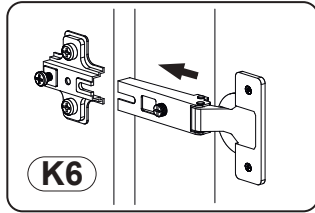
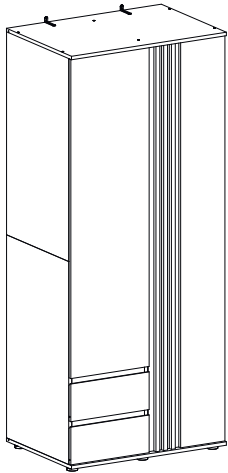

28

R

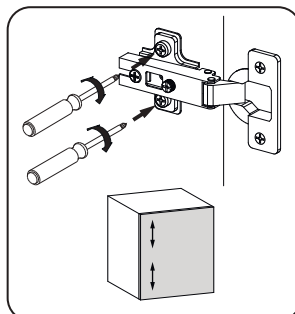
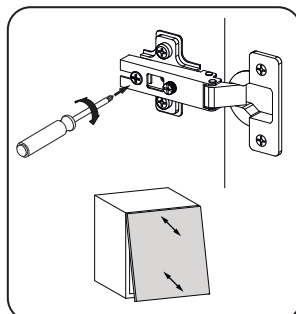
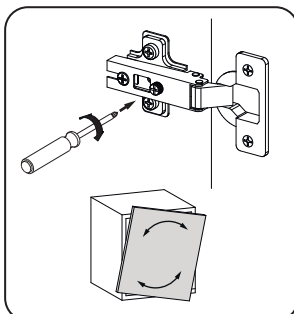
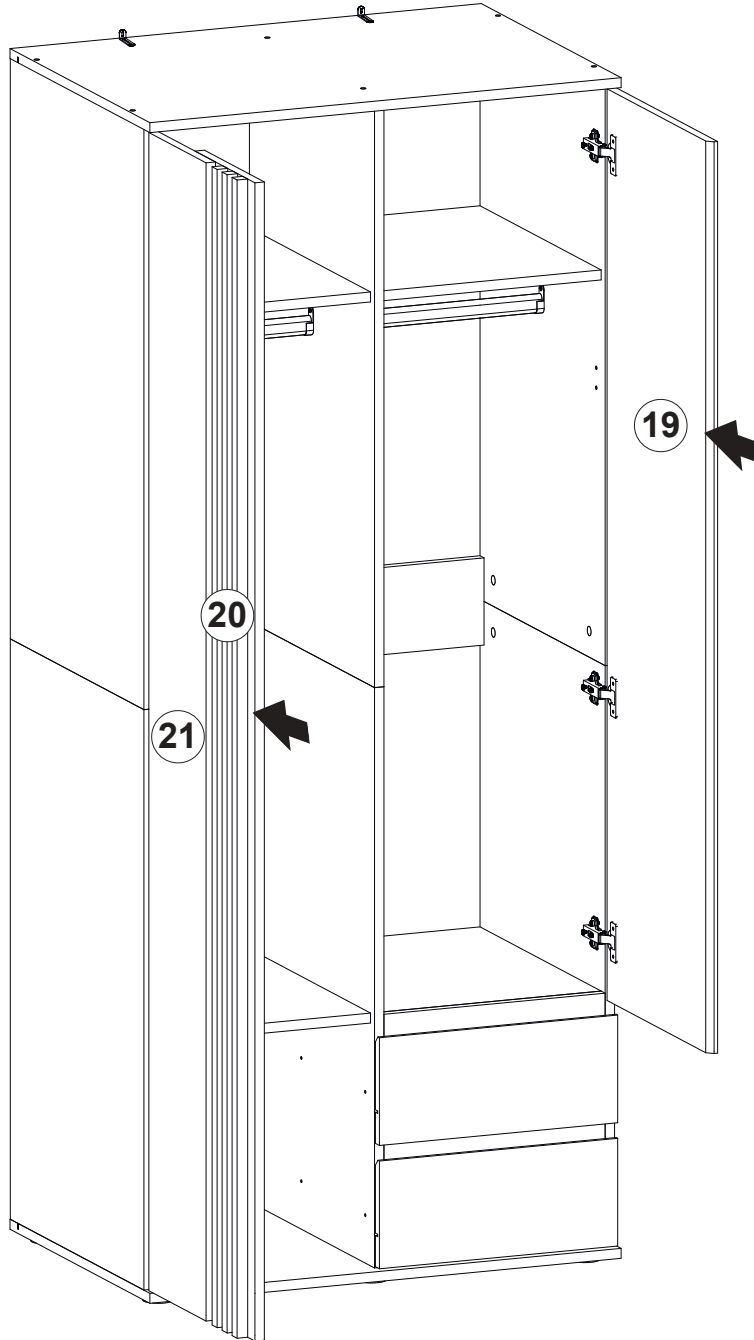
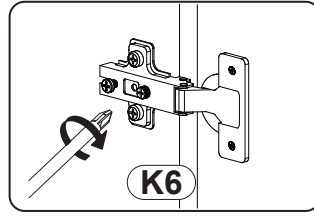
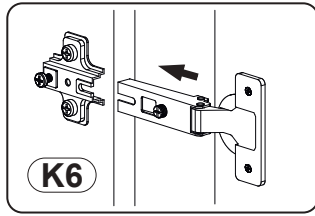
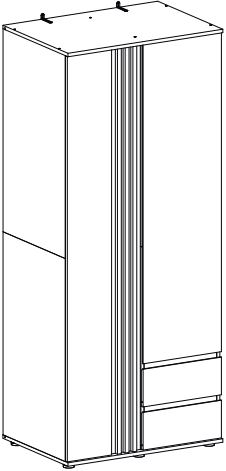

**L**



**R**

