

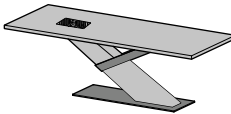

Montage Speisetisch 1506 / 1507 / 1508 / 1509 / 1510 / 1511

| Esstisch mit fester Platte  | Baumkante  | | gerade Kante mit Hirnholz  | | gesoftete Kante  | |
|---|--|-----------------|---|-----------------|--|-----------------|
| | Kerneiche Umato | Kerneiche Natur | Kerneiche Umato | Kerneiche Natur | Kerneiche Umato | Kerneiche Natur |
| Maße in cm | Artikel-Nr. | Artikel-Nr. | Artikel-Nr. | Artikel-Nr. | Artikel-Nr. | Artikel-Nr. |
| L 190 B 95 H 76 | 7100E - 1506 | 8400E - 1506 | 7100E - 1508 | 8400E - 1508 | 7100E - 1510 | 8400E - 1510 |
| L 240 B 110 H 76 | 7100E - 1507 | 8400E - 1507 | 7100E - 1509 | 8400E - 1509 | 7100E - 1511 | 8400E - 1511 |

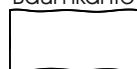

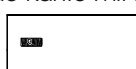
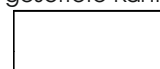

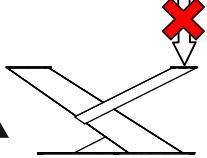
Während der Montage nur geringen Druck auf Metallrahmen ausüben! Bruchgefahr. Erst nach kompletter Montage vollständig belastbar!

Only exert slight pressure on metal frames during assembly! Risk of breakage. Only fully loadable after complete assembly!



Montage mit zwei Personen durchführen!
Carry out assembly with two people!



1. Tischplatte auf Untergestell positionieren

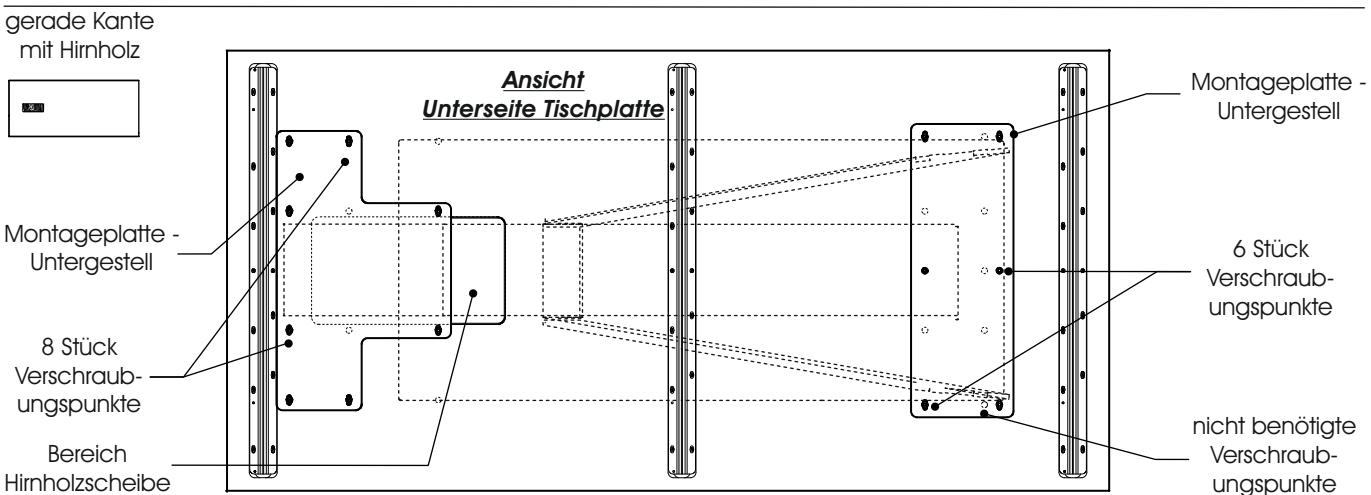
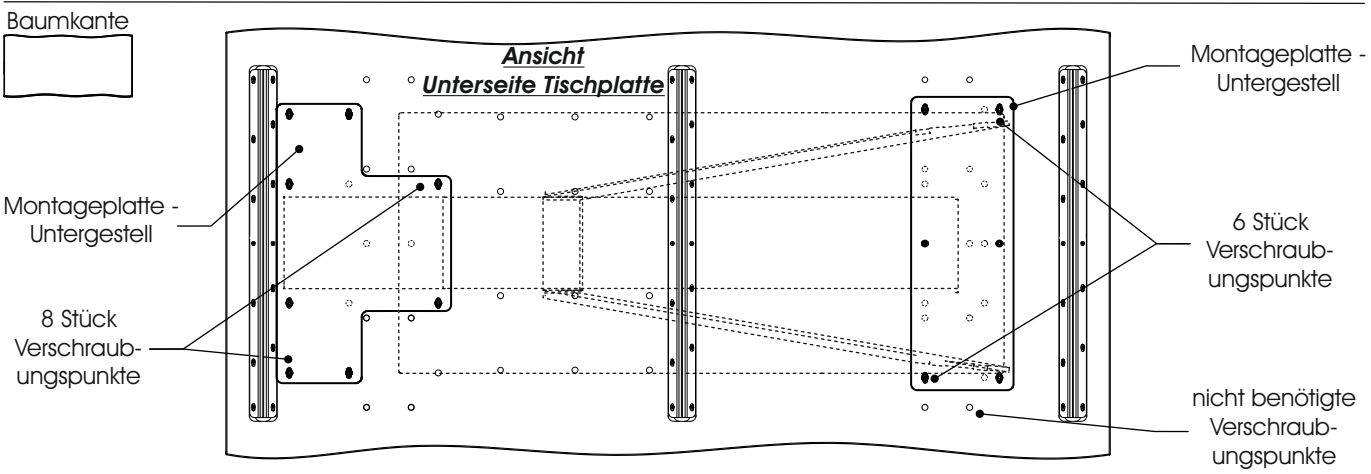
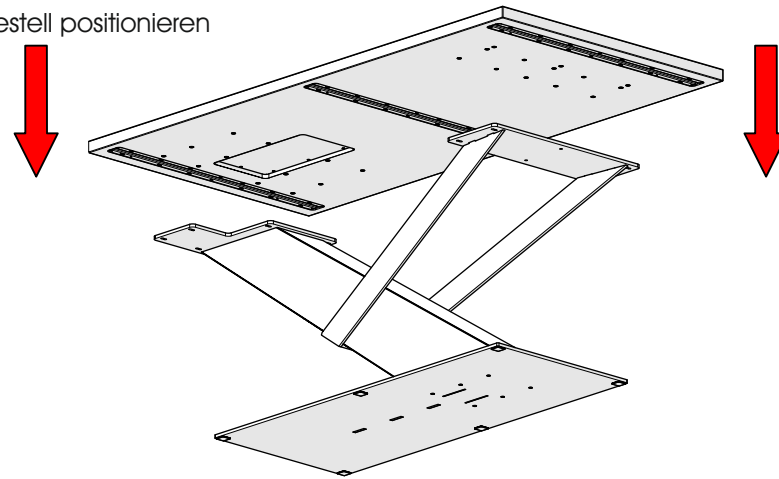

Montage Speisetisch 1506 / 1507 / 1508 / 1509 / 1510 / 1511

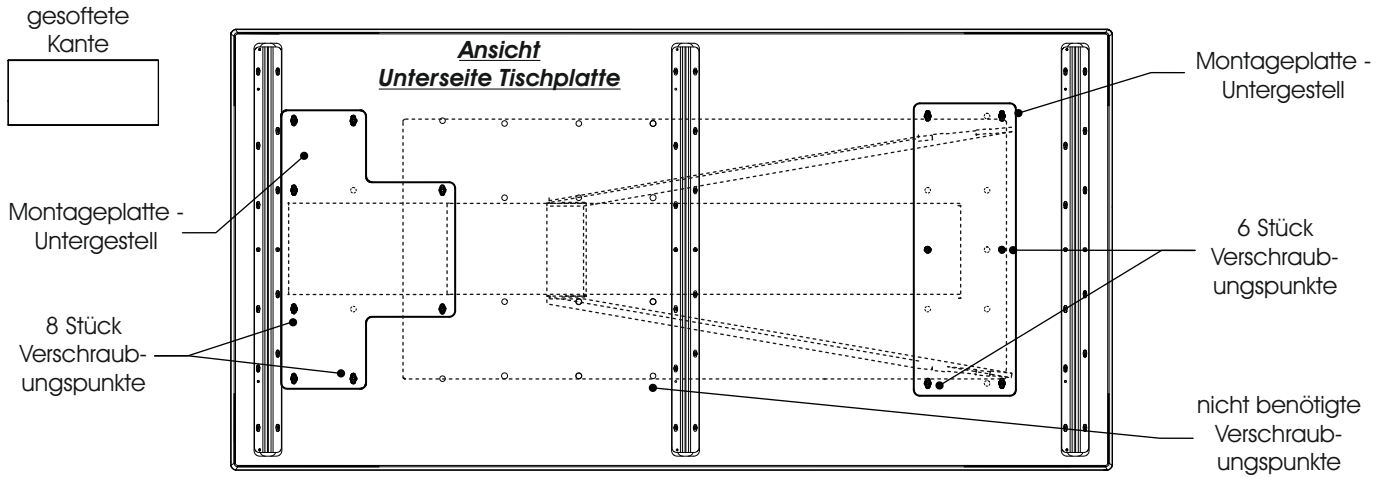

2. Tischplatte auf Untergestell verschrauben

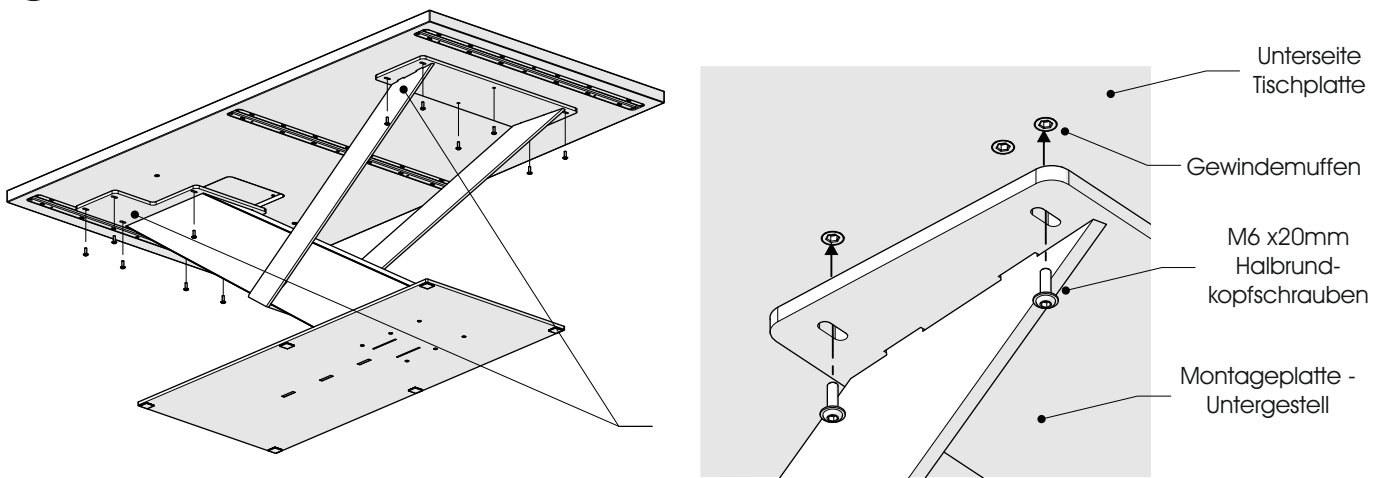

3. Eventualposition: Höhen- / Nivellierausgleich falls notwendig

