

ASSEMBLY INSTRUCTION 18280008-09

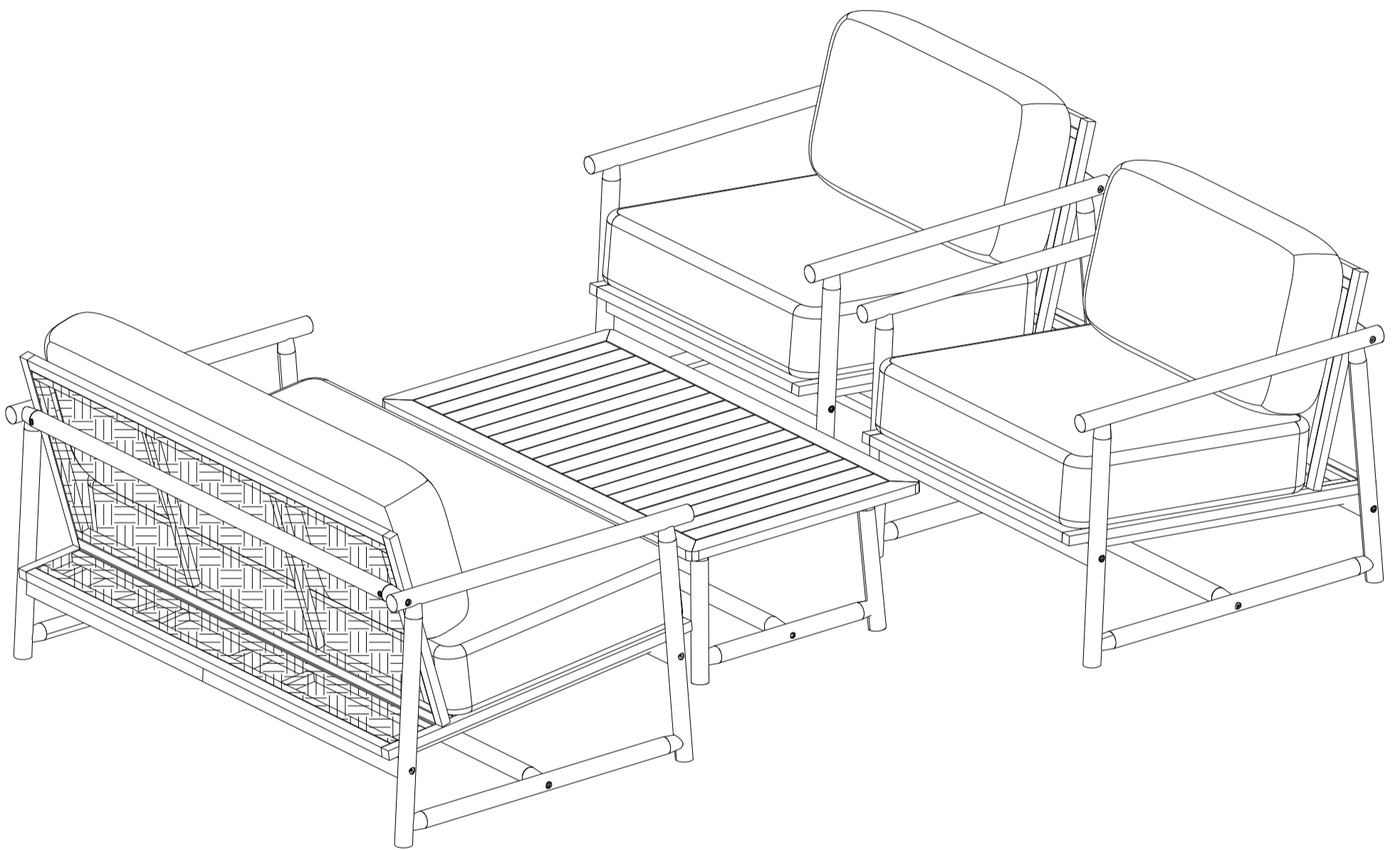

ASSEMBLY INSTRUCTION 18280008-09

A | 3pcs

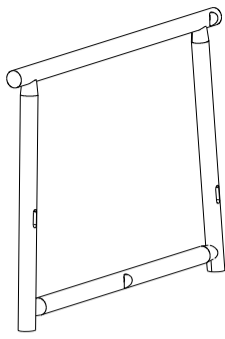

B | 3pcs

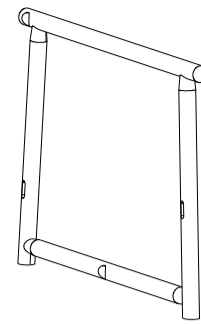

C | 2pcs

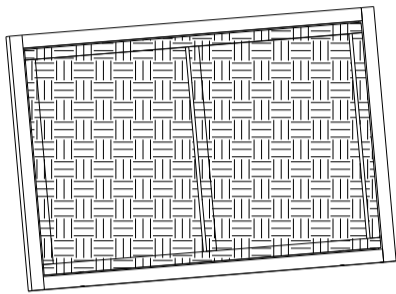

D | 2pcs

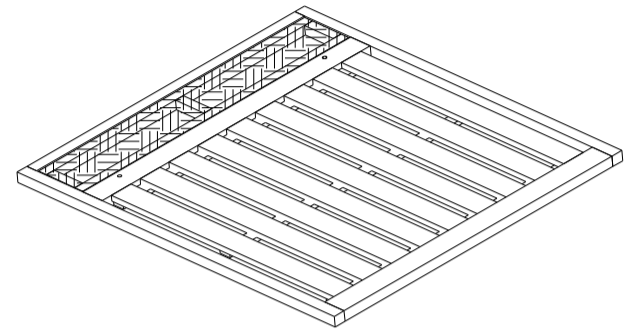

E | 2pcs

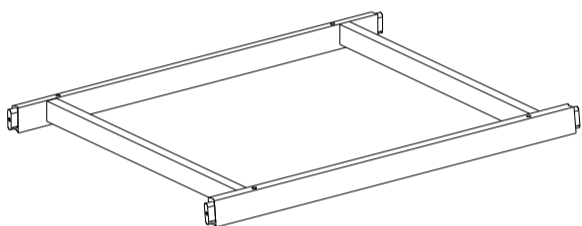

F | 2pcs

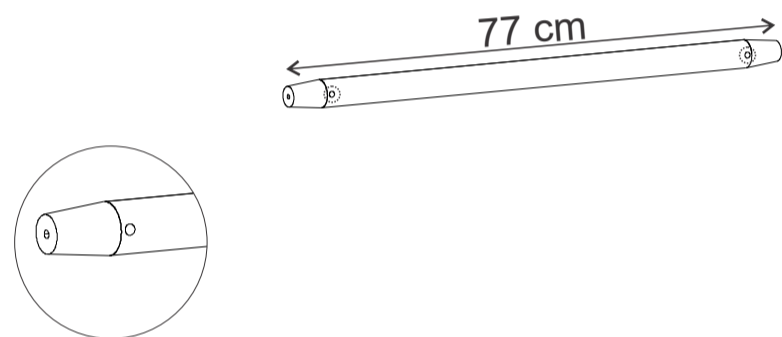

G | 2pcs

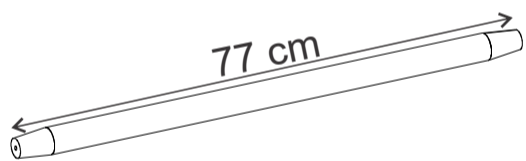

H | 1pc

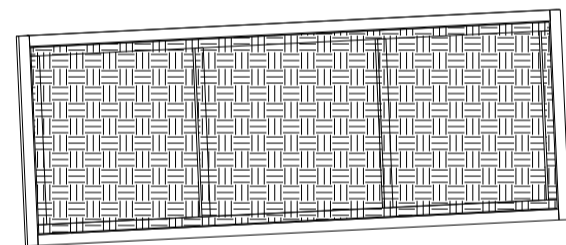

I | 1pc

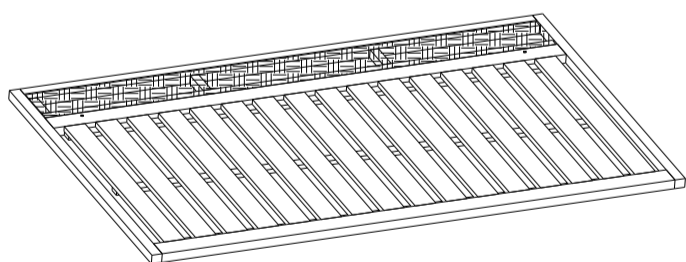

J | 1pc

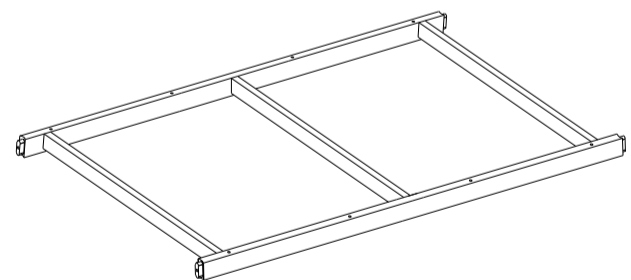

K | 1pc

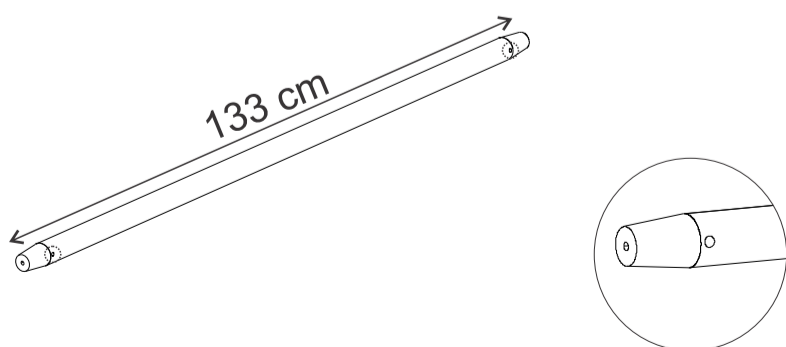

L | 1pc

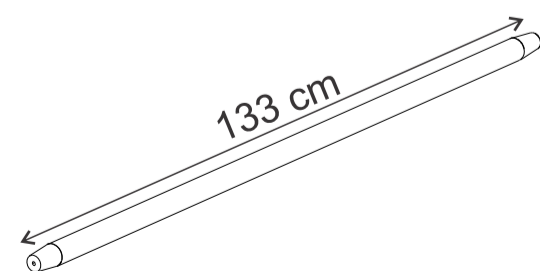

ASSEMBLY INSTRUCTION 18280008-09

M | 2pcs

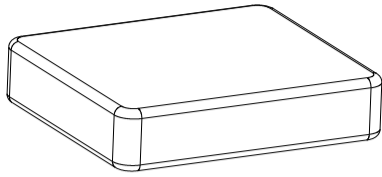

N | 1pc

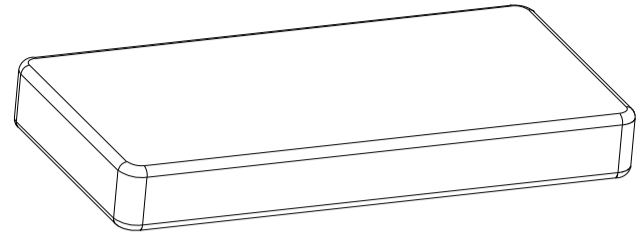

O | 2pcs

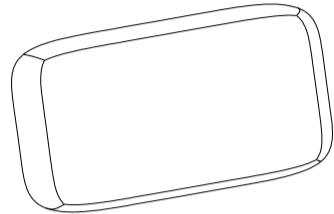

P | 1pc

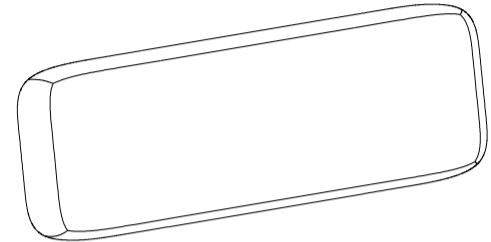

Q | 1pc

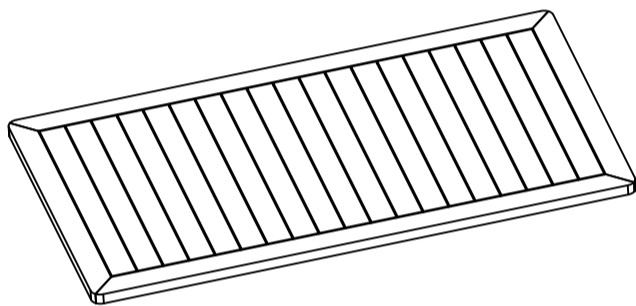

R | 2pcs

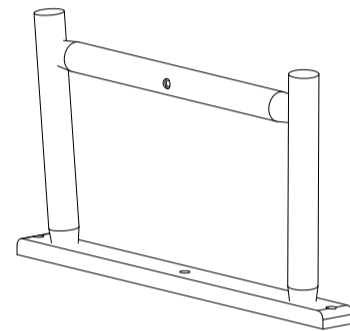

S | 1pc

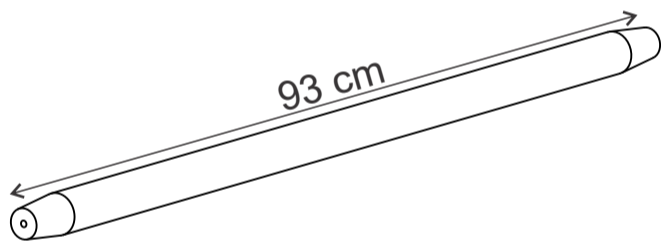

① 26pcs

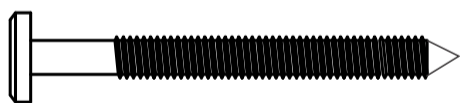

Vis M7x60

② 16pcs

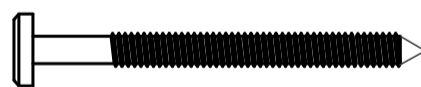

Vis M6x60

③ 12pcs



Vis M6x50

④ 6pcs



BOLT M6x35

⑤ 4pcs

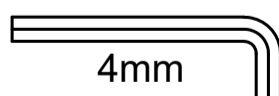

4mm

ASSEMBLY INSTRUCTION 18280008-09

1

X2

Tighten bolts

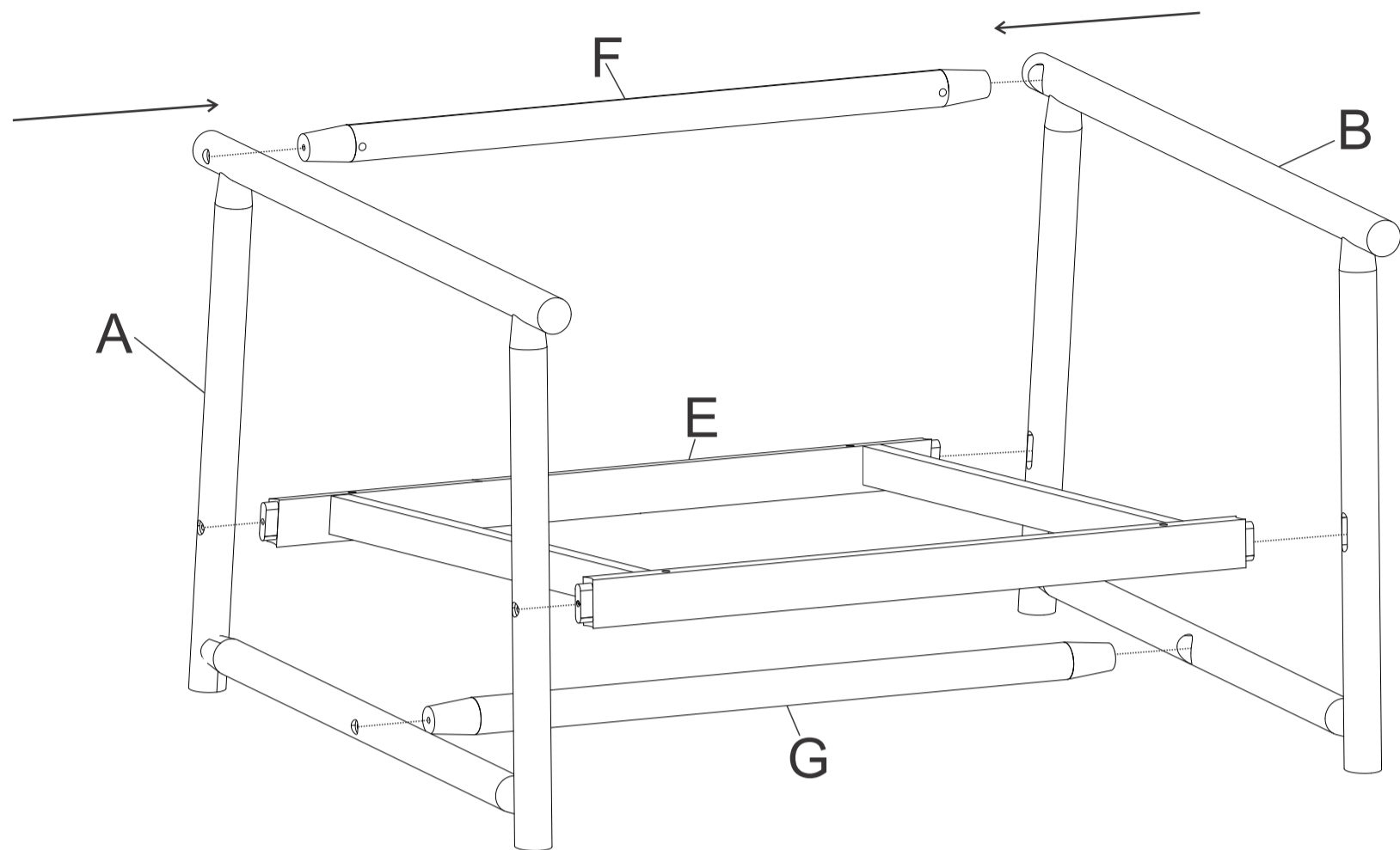

2

X2

Tighten bolts

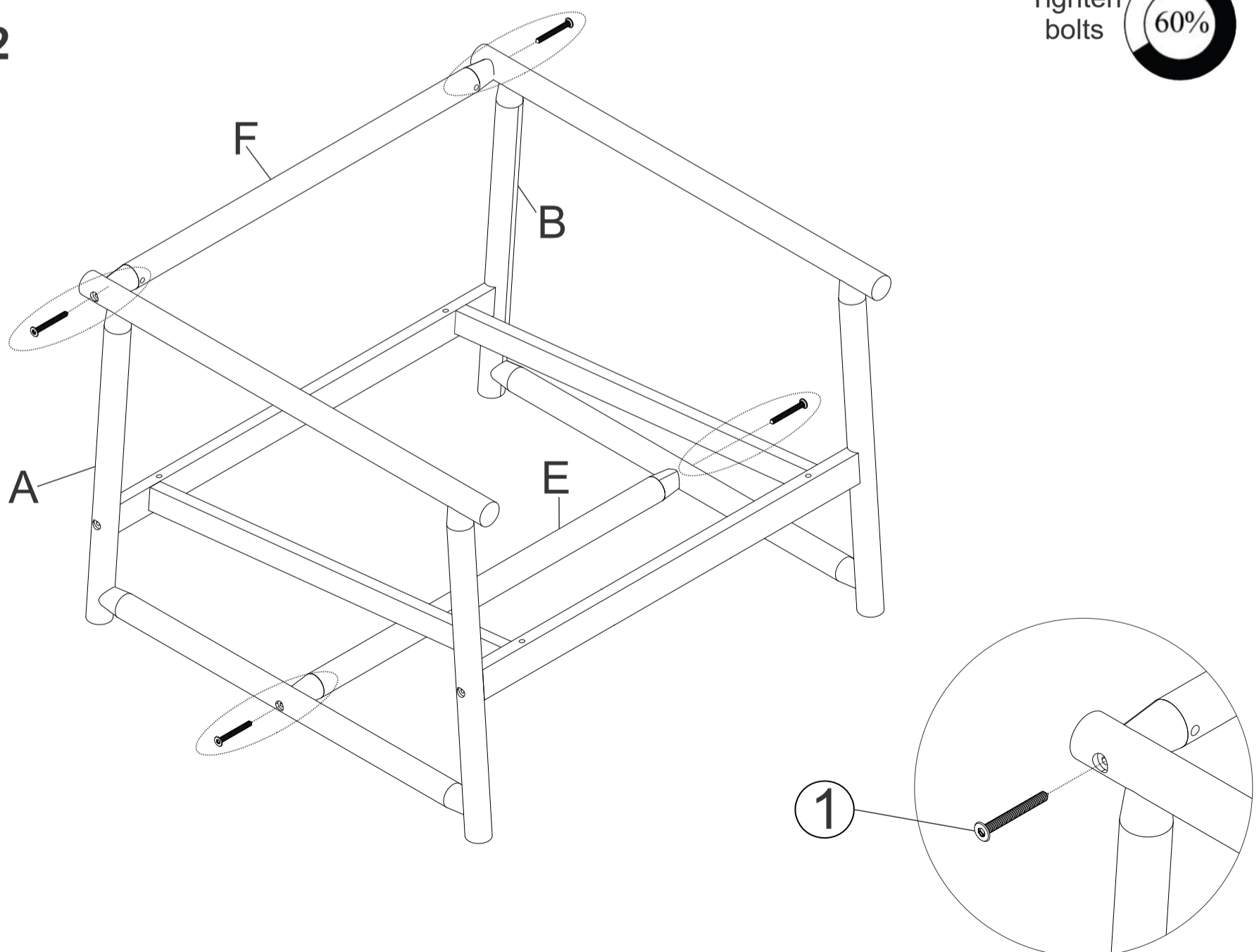

ASSEMBLY INSTRUCTION 18280008-09

3

X2

Tighten bolts

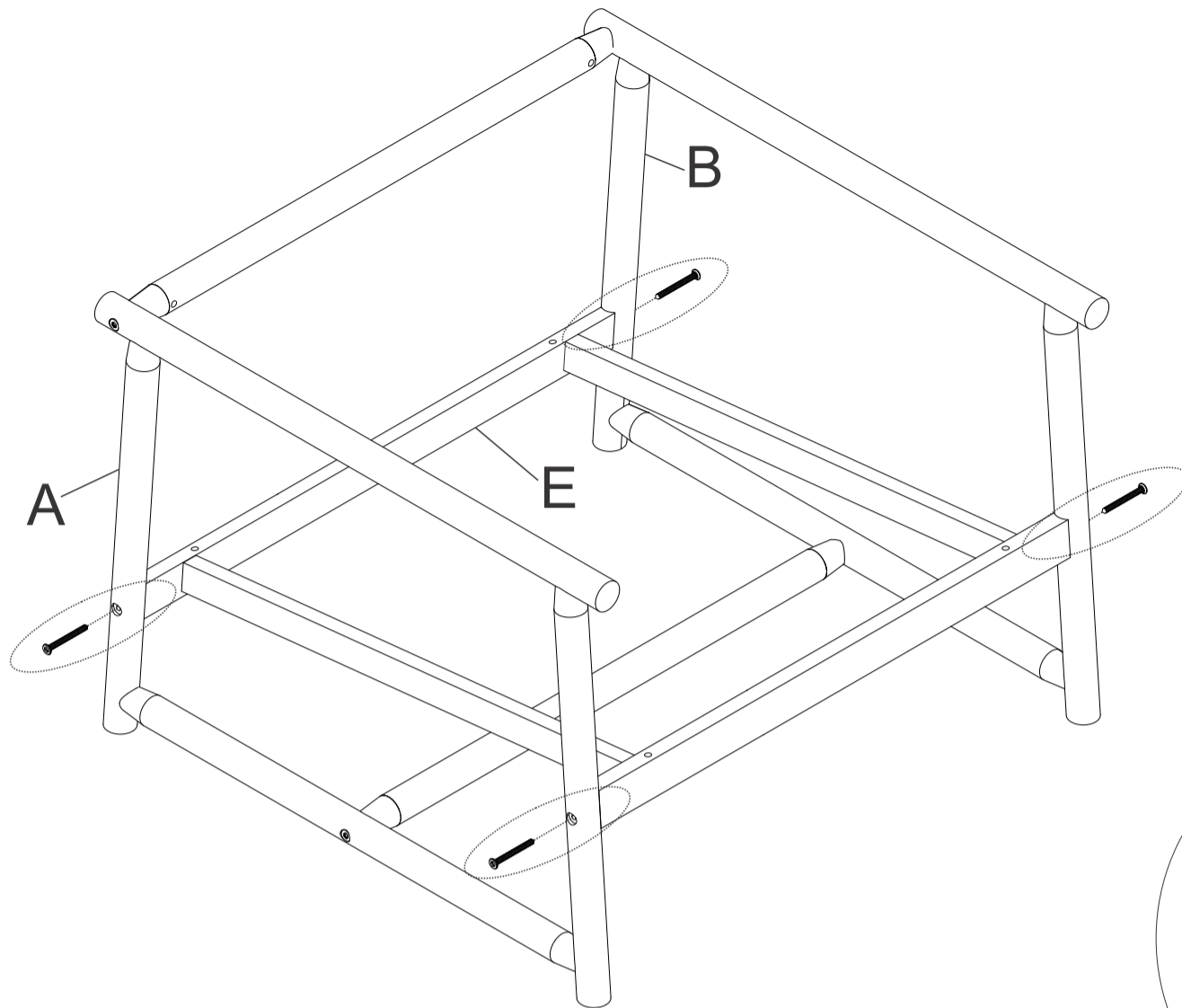

1

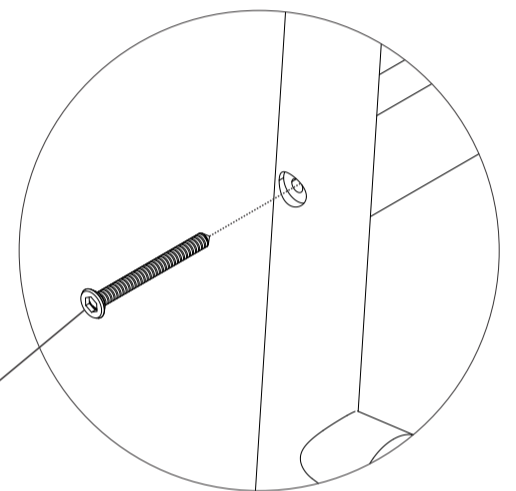

4

X2

Tighten bolts

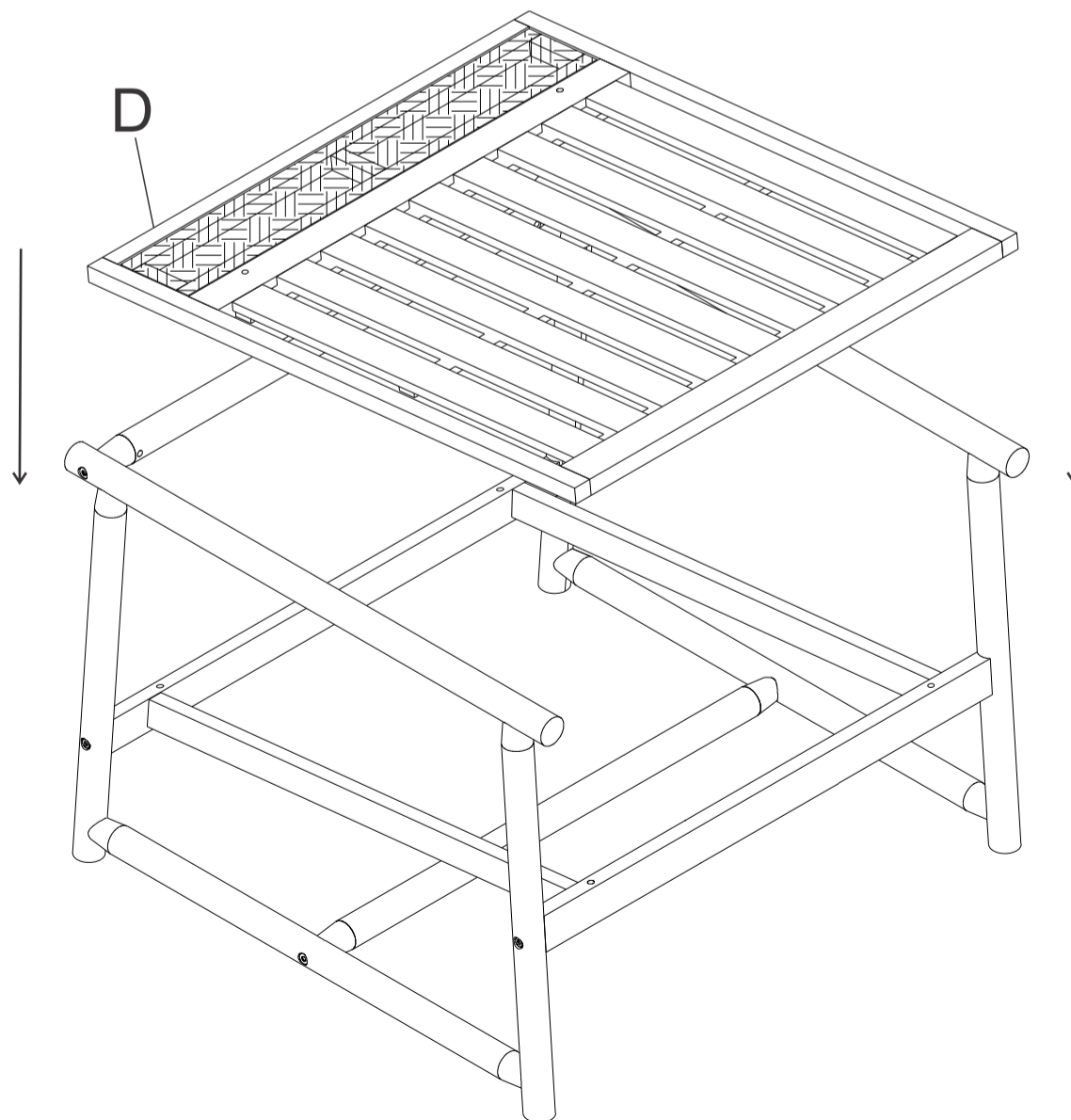

ASSEMBLY INSTRUCTION 18280008-09

5

X2

Tighten bolts

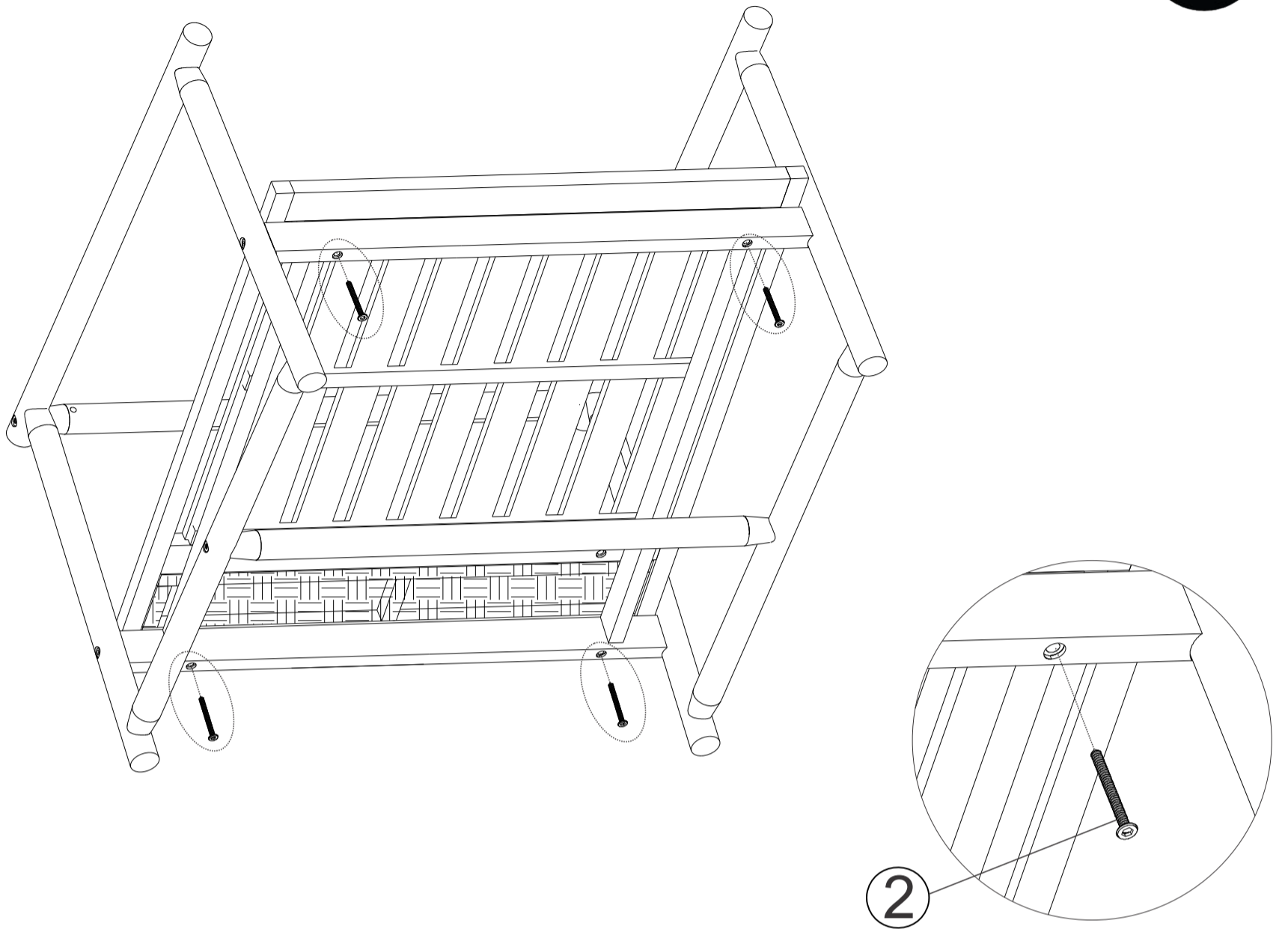

6

X2

Tighten bolts

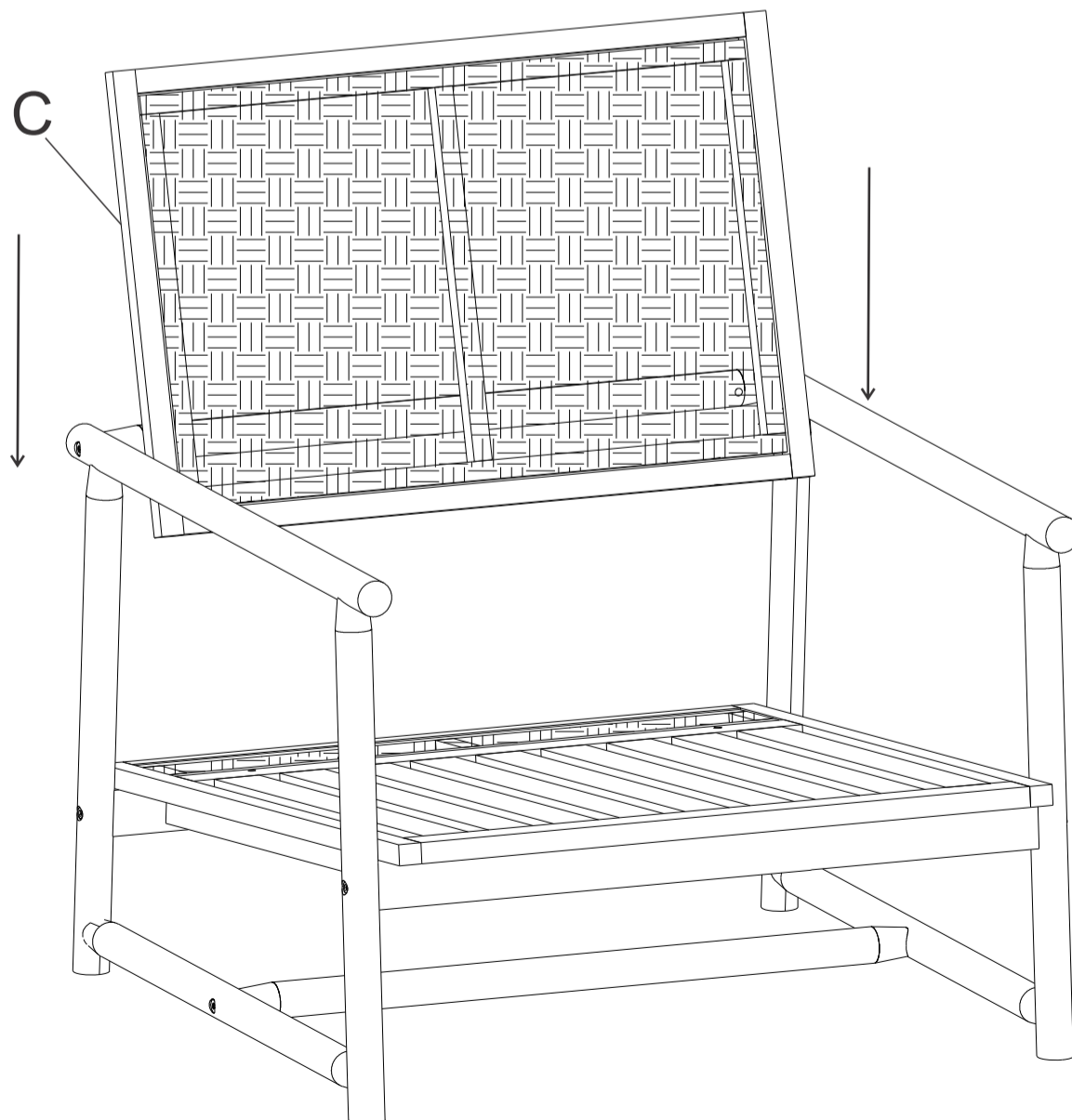

ASSEMBLY INSTRUCTION 18280008-09

7

X2

Tighten bolts

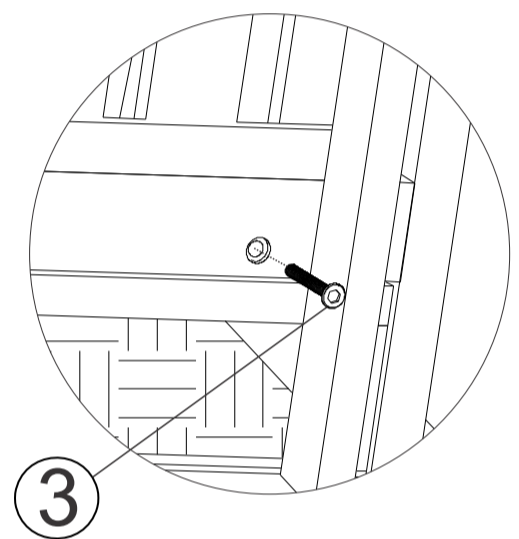
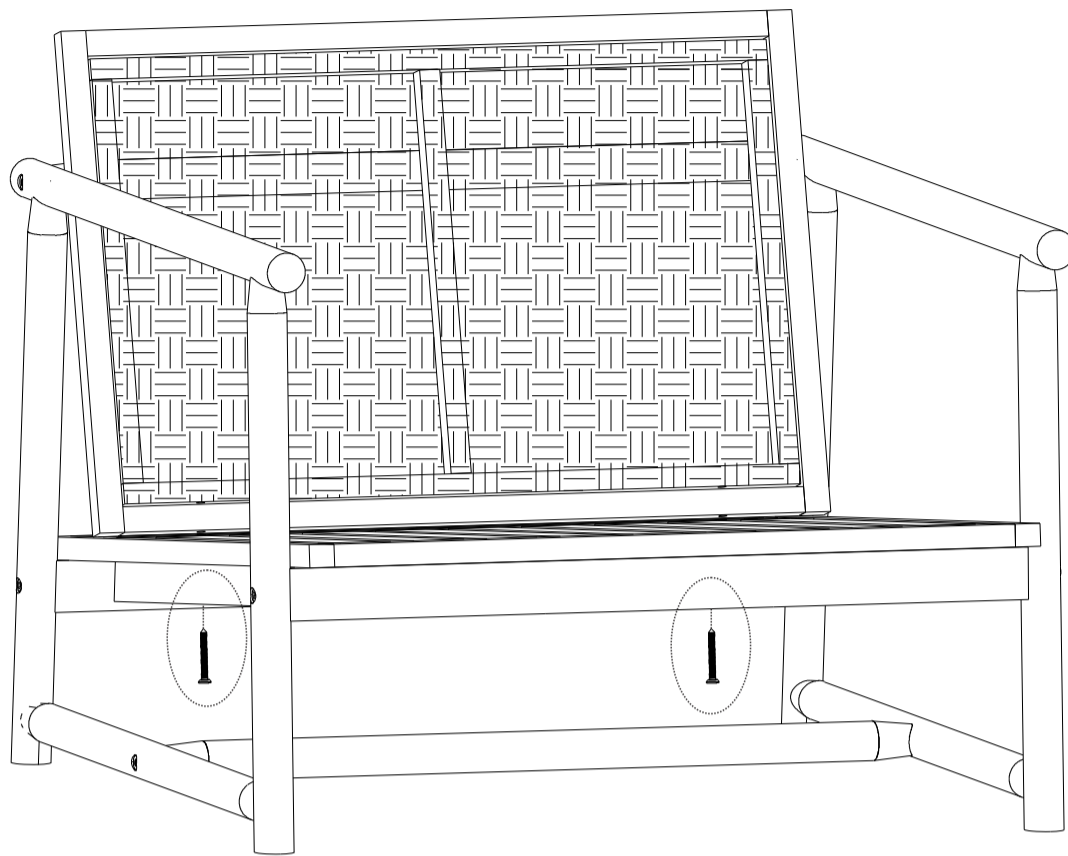

8

X2

Tighten bolts

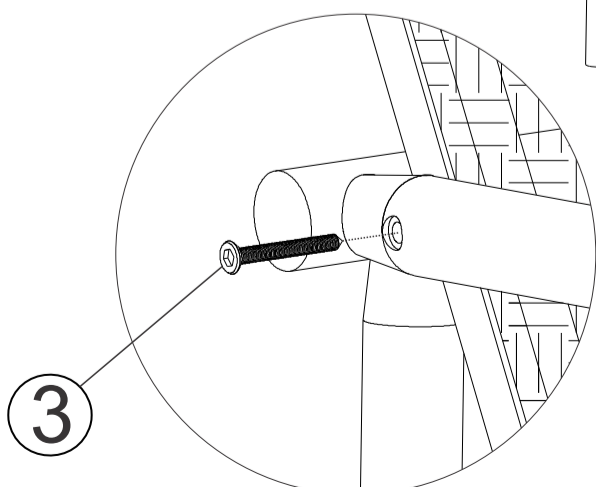
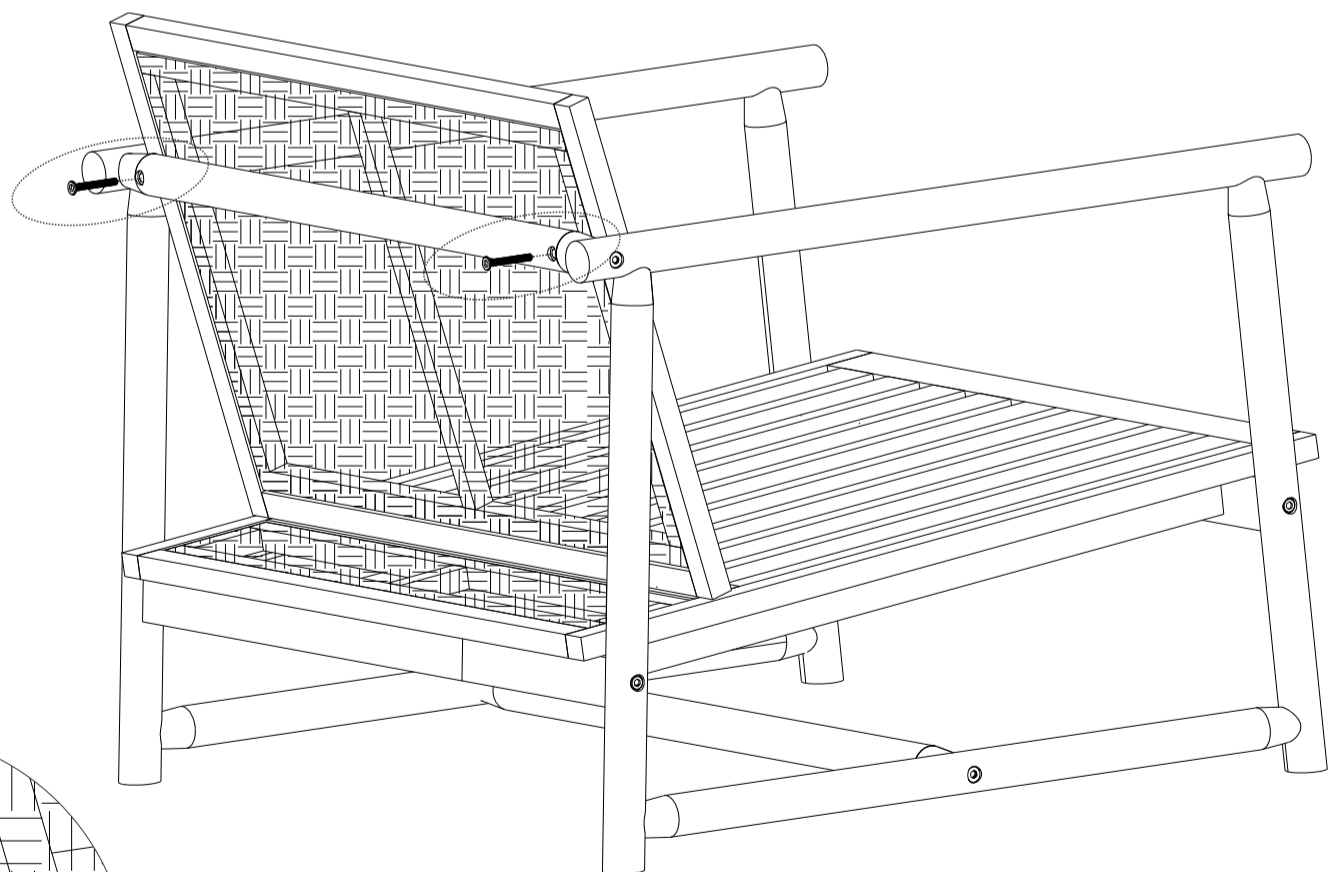

ASSEMBLY INSTRUCTION 18280008-09

9

X2

Tighten bolts

100%

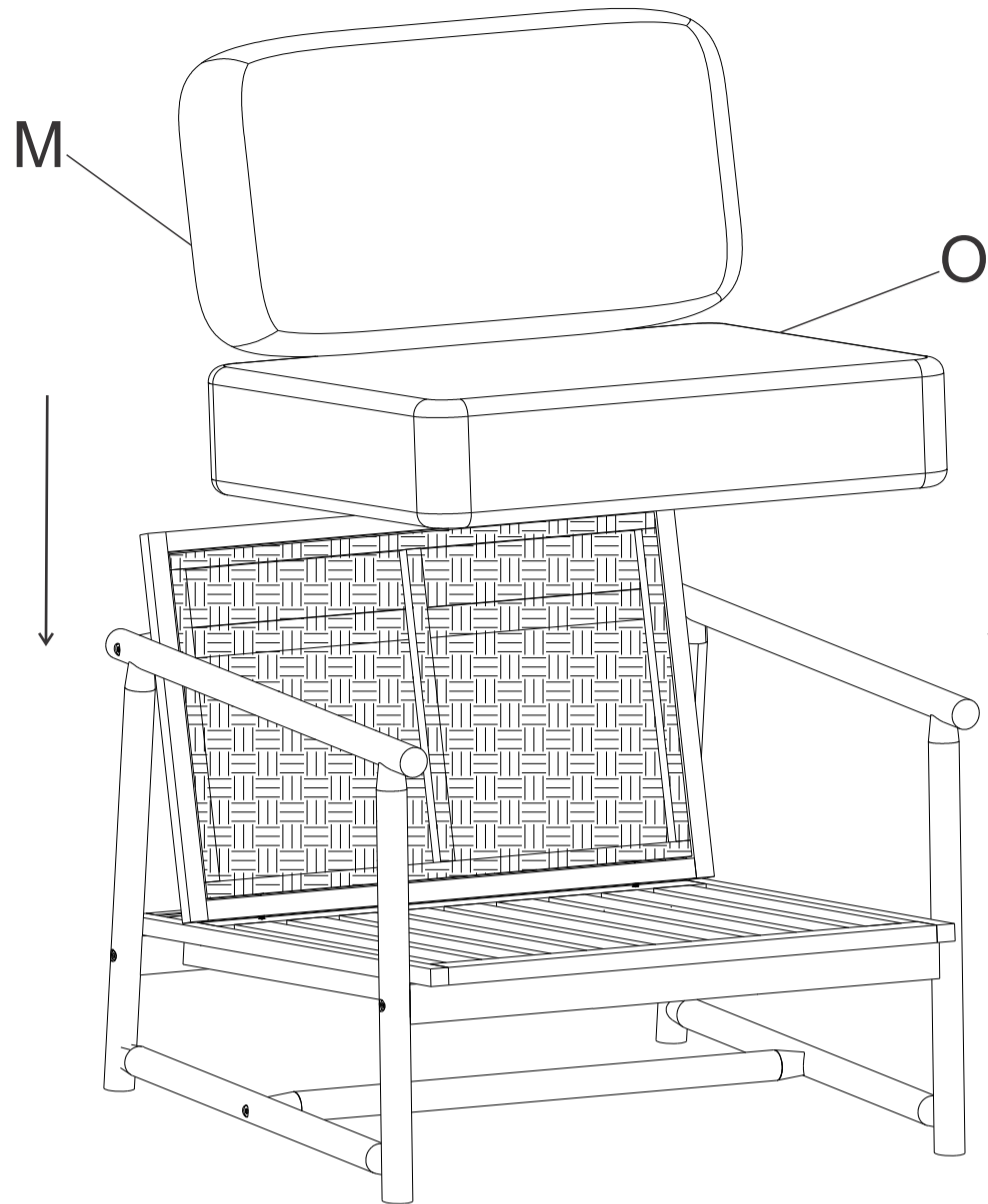

10

X2

Tighten bolts

100%

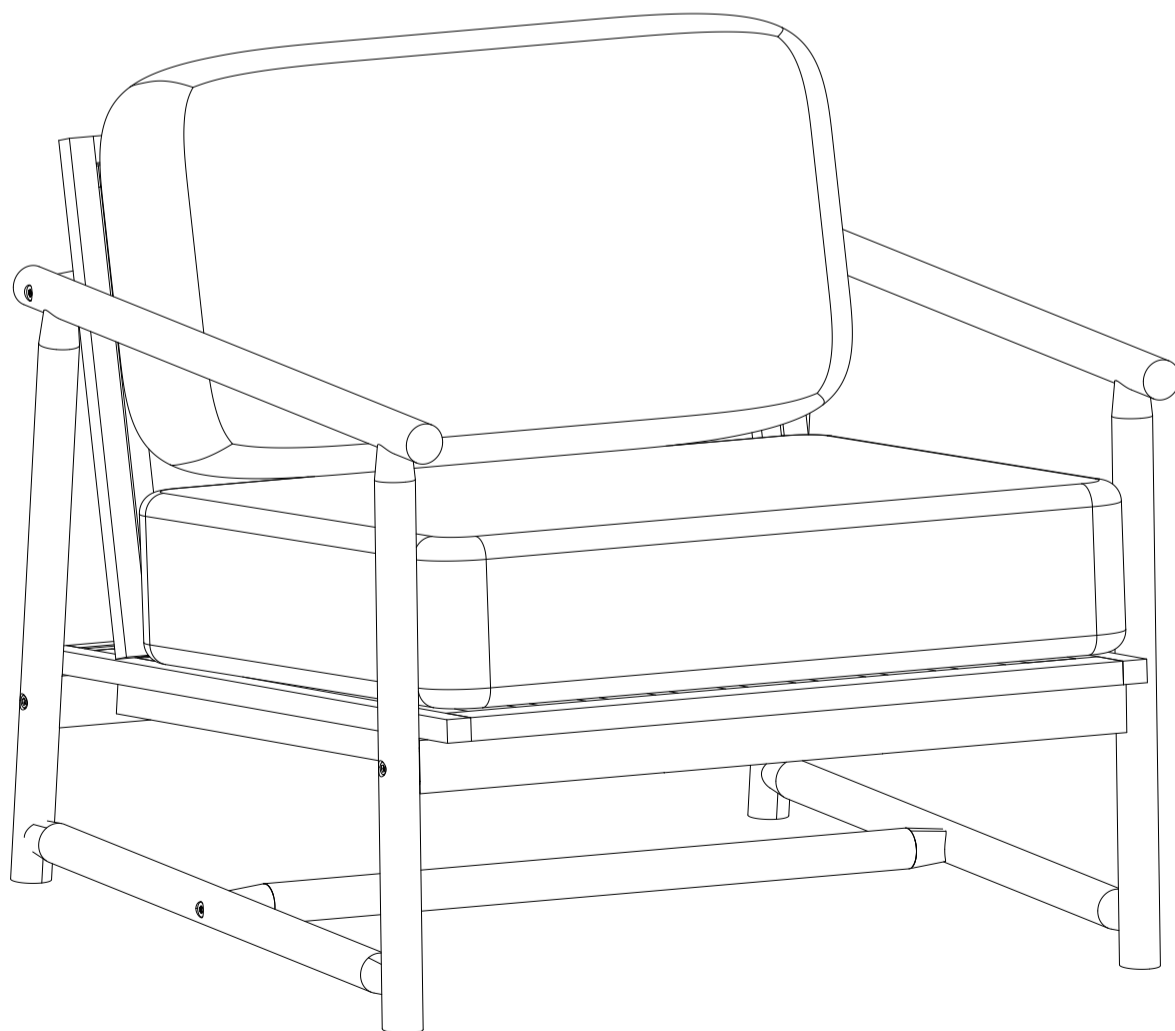

ASSEMBLY INSTRUCTION 18280008-09

11

Tighten bolts 

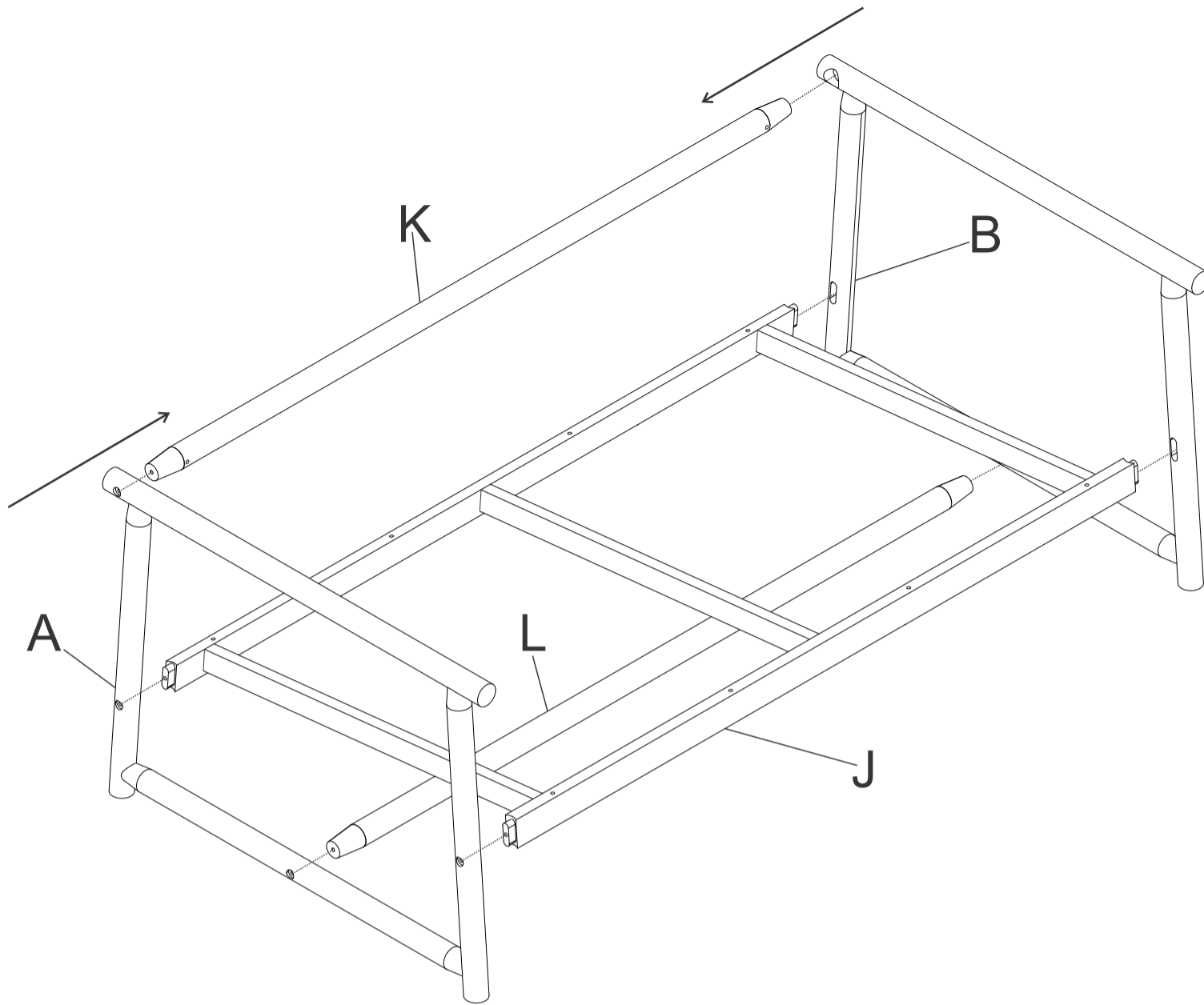

12

Tighten bolts 

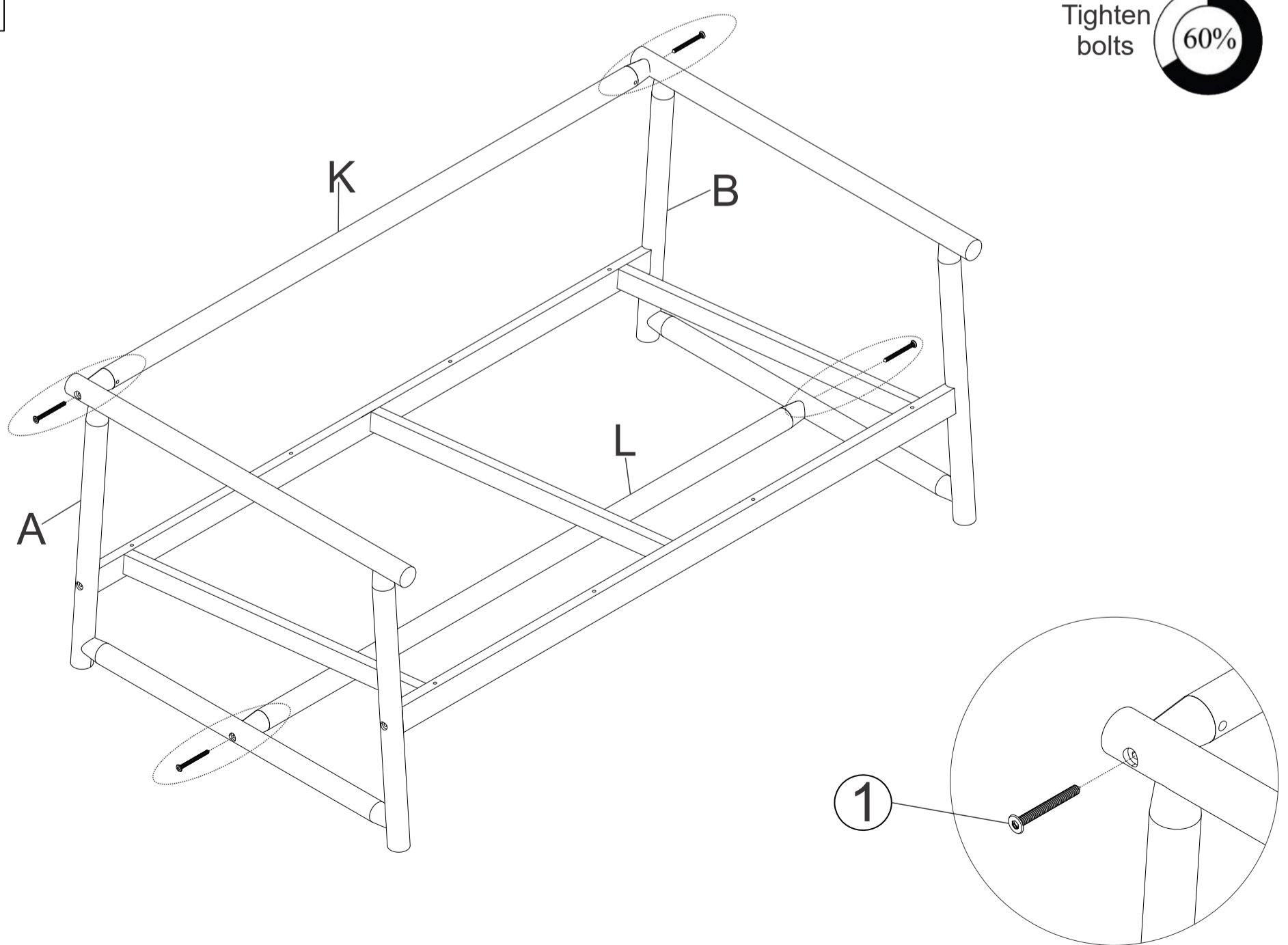

ASSEMBLY INSTRUCTION 18280008-09

13

Tighten bolts

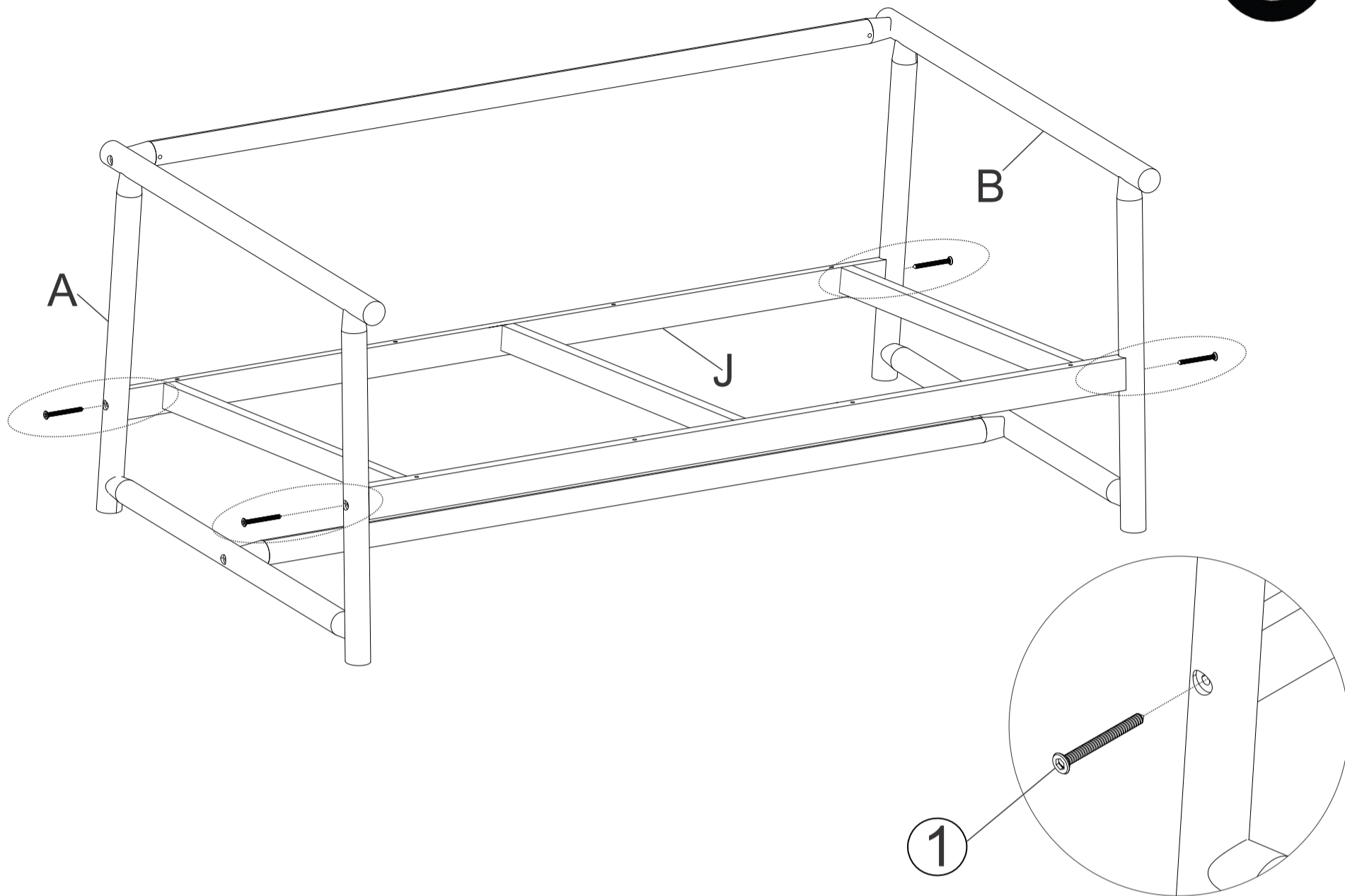
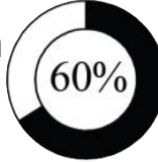

14

Tighten bolts

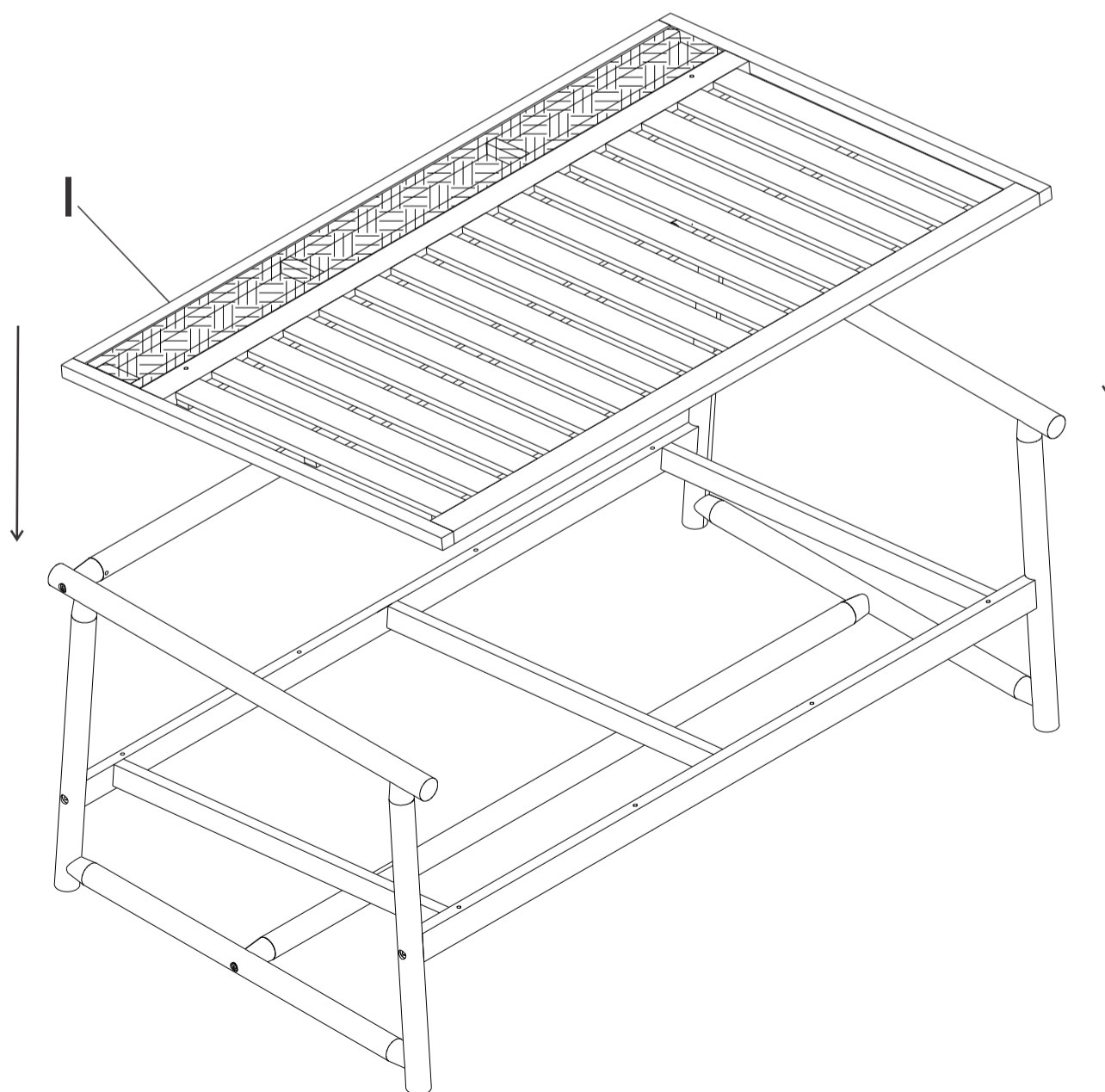

ASSEMBLY INSTRUCTION 18280008-09

15

Tighten bolts 

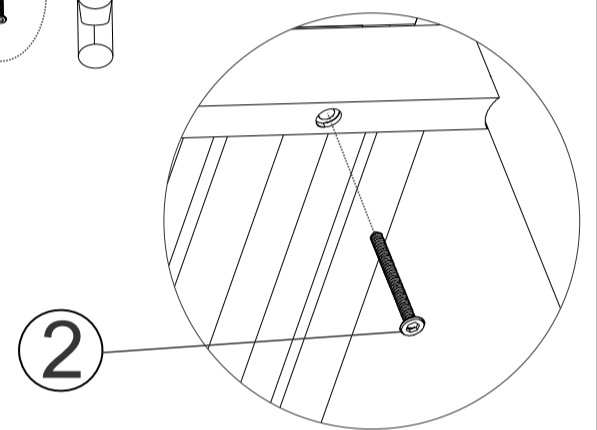
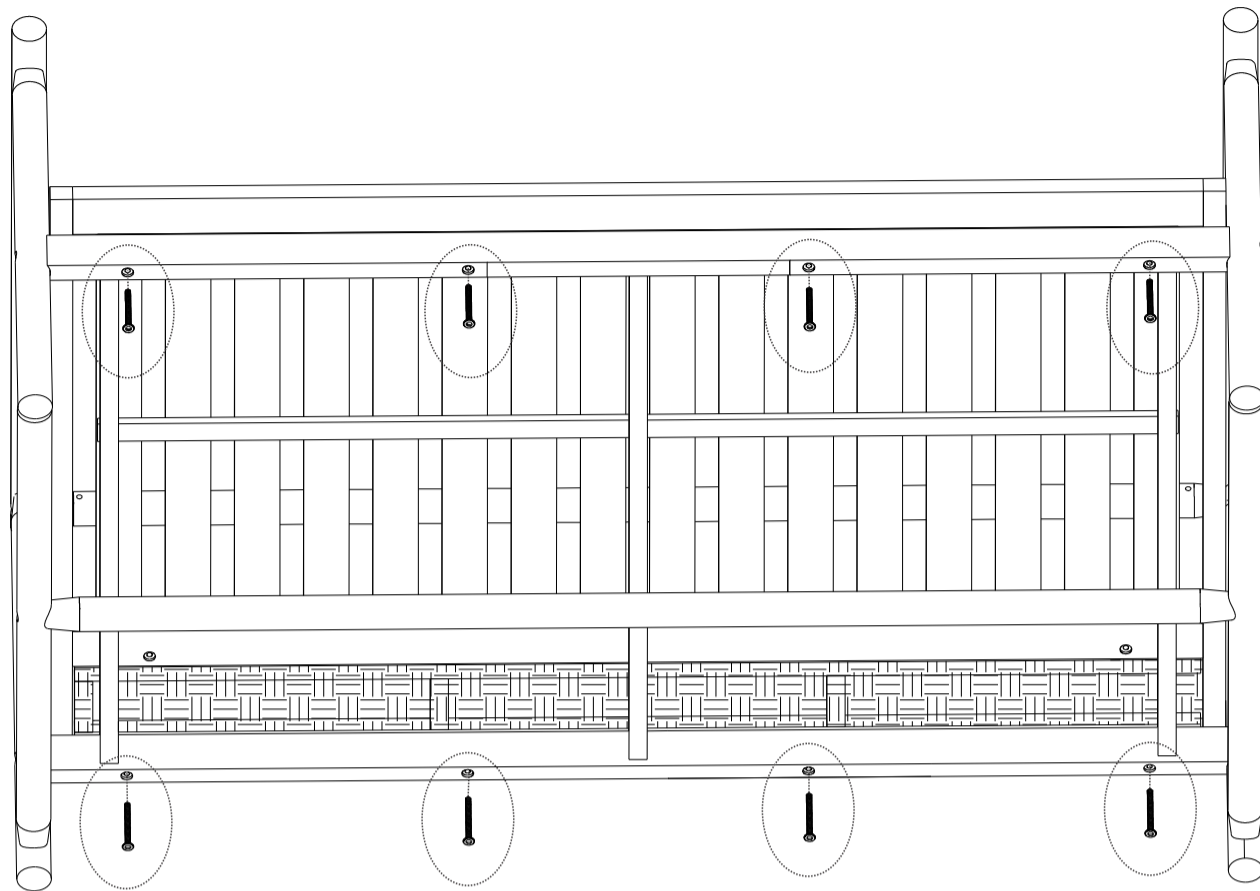

16

Tighten bolts 

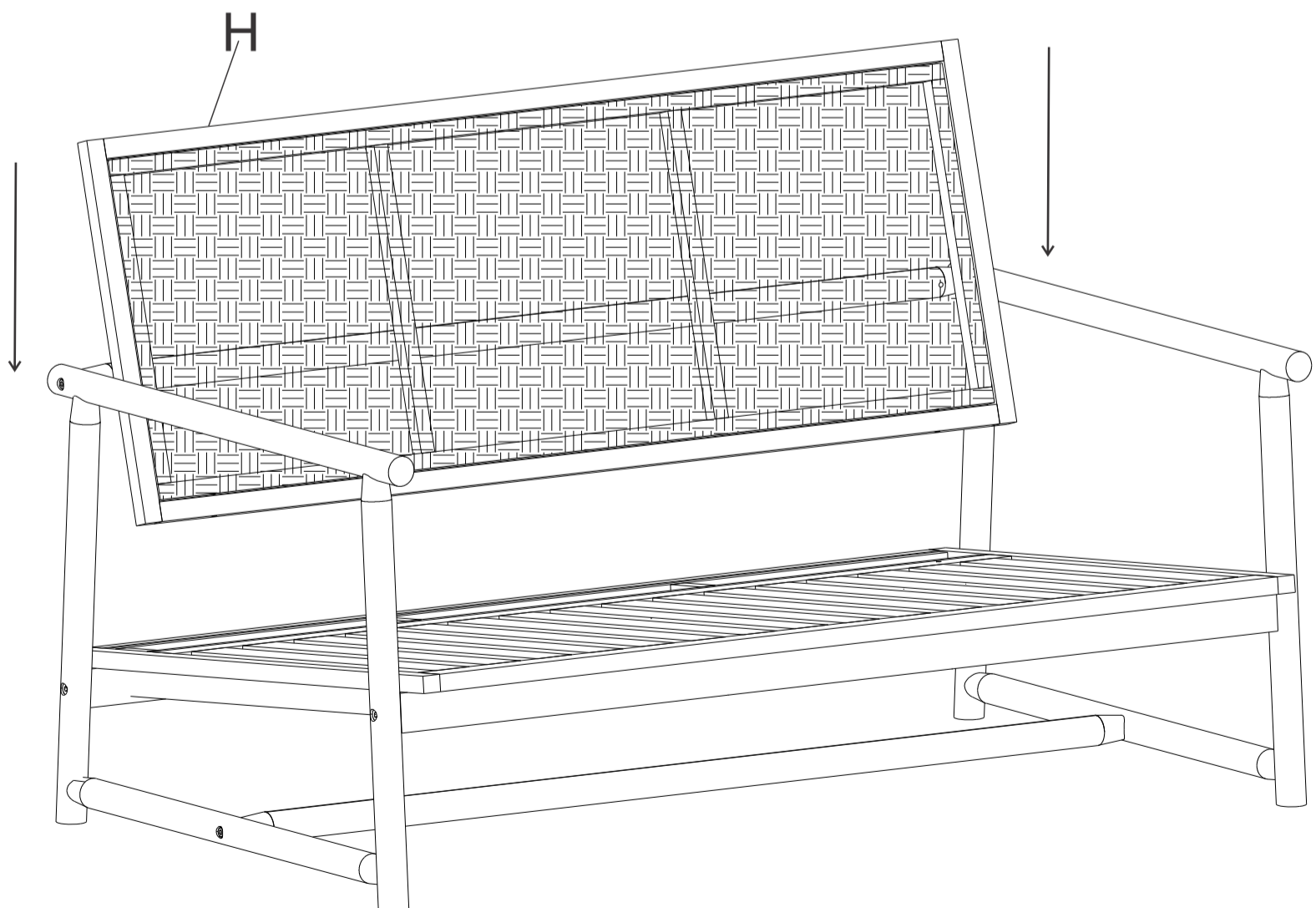

ASSEMBLY INSTRUCTION 18280008-09

17

Tighten bolts

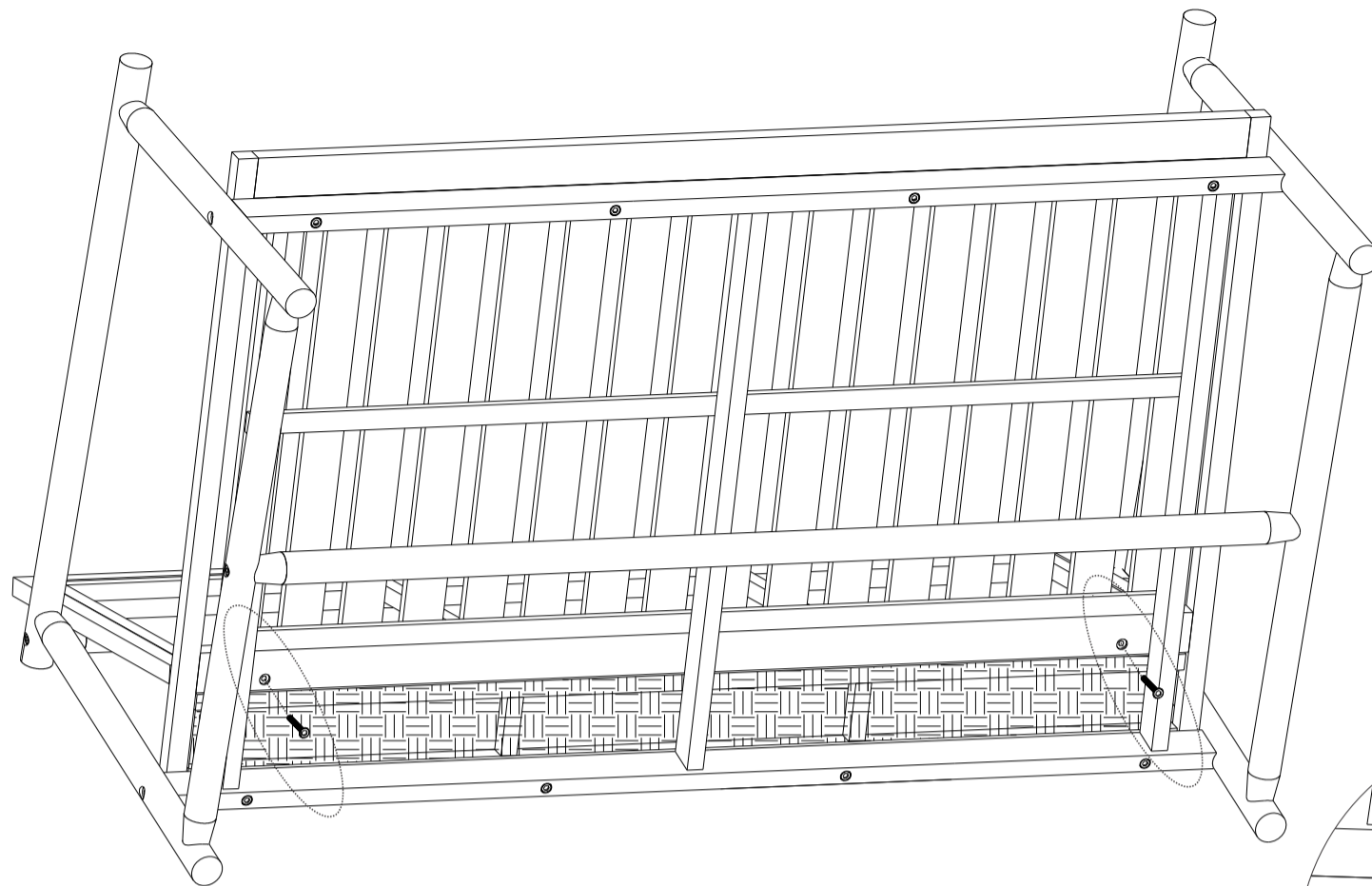
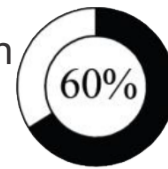

3

18

Tighten bolts

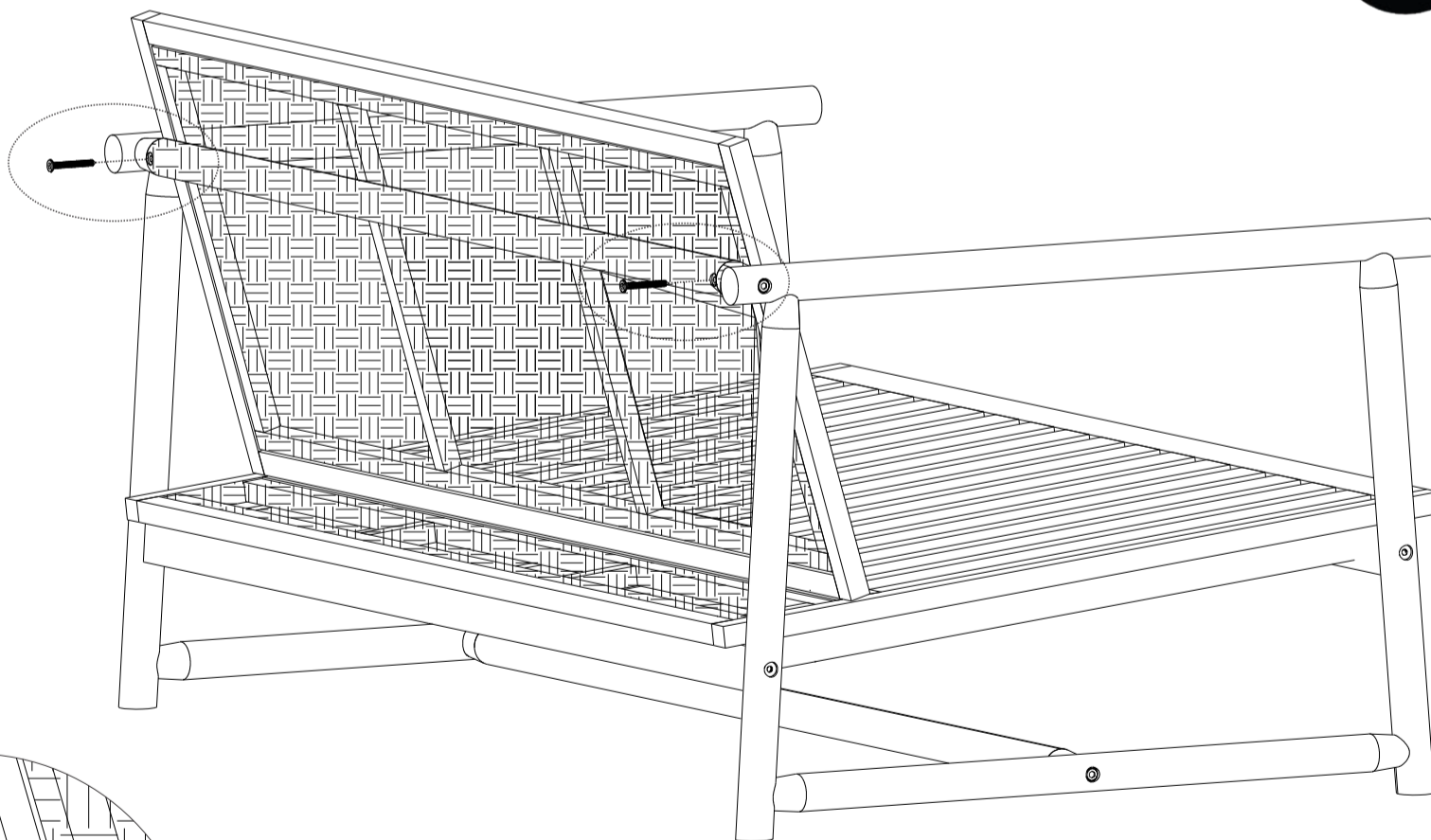
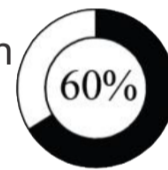

3



ASSEMBLY INSTRUCTION 18280008-09

19

Tighten bolts

100%

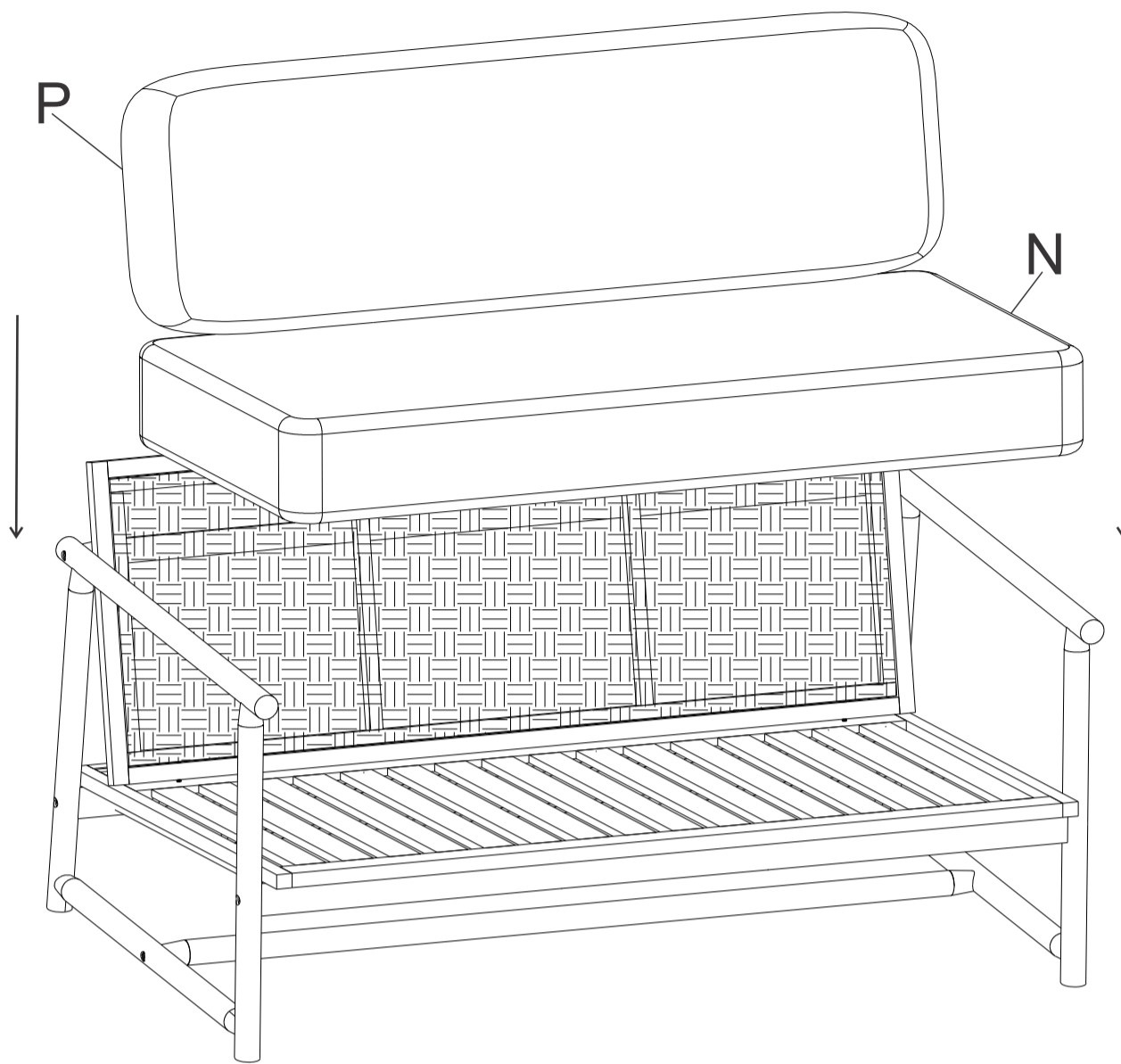

20

Tighten bolts

100%

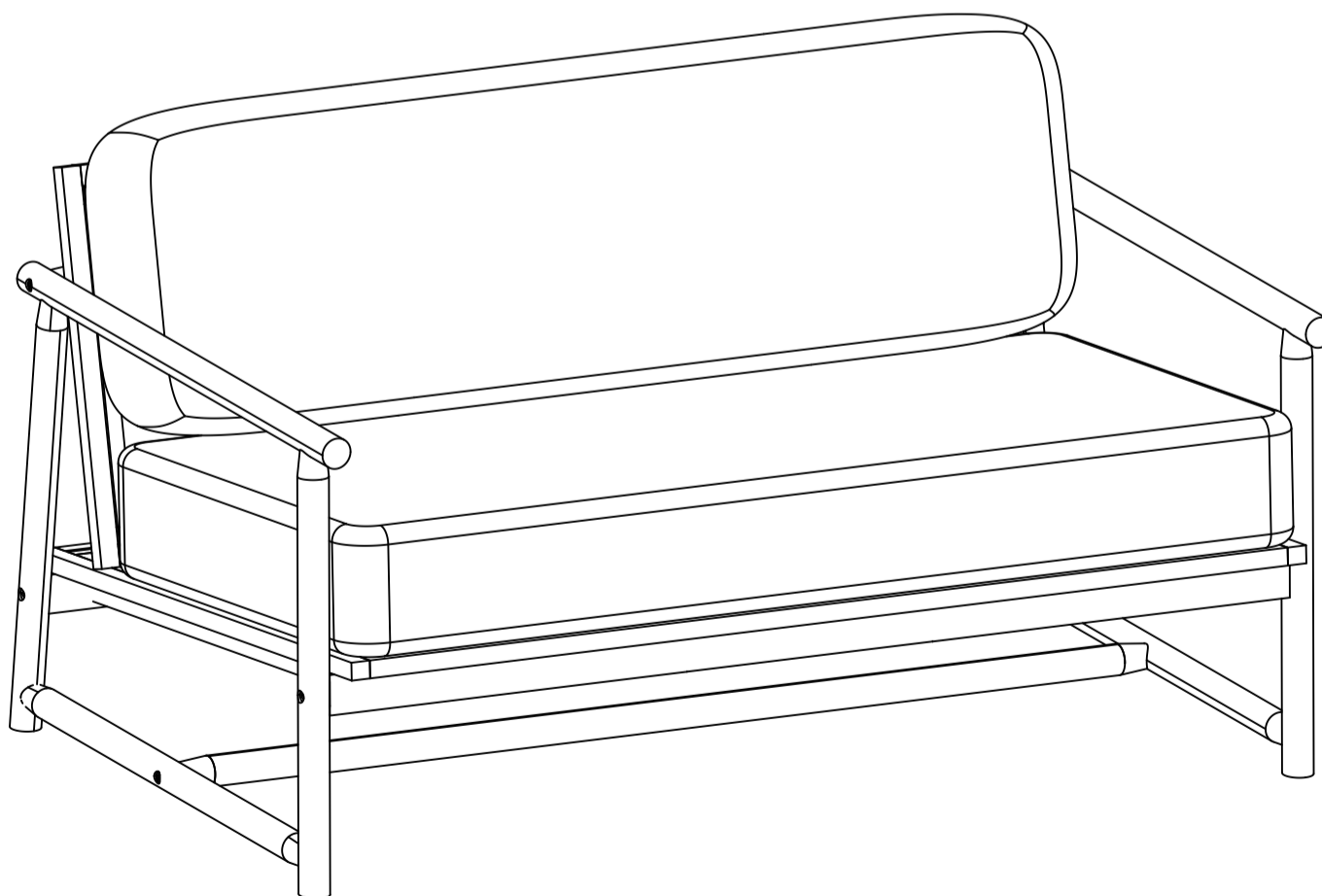

ASSEMBLY INSTRUCTION 18280008-09

21

Tighten bolts

60%

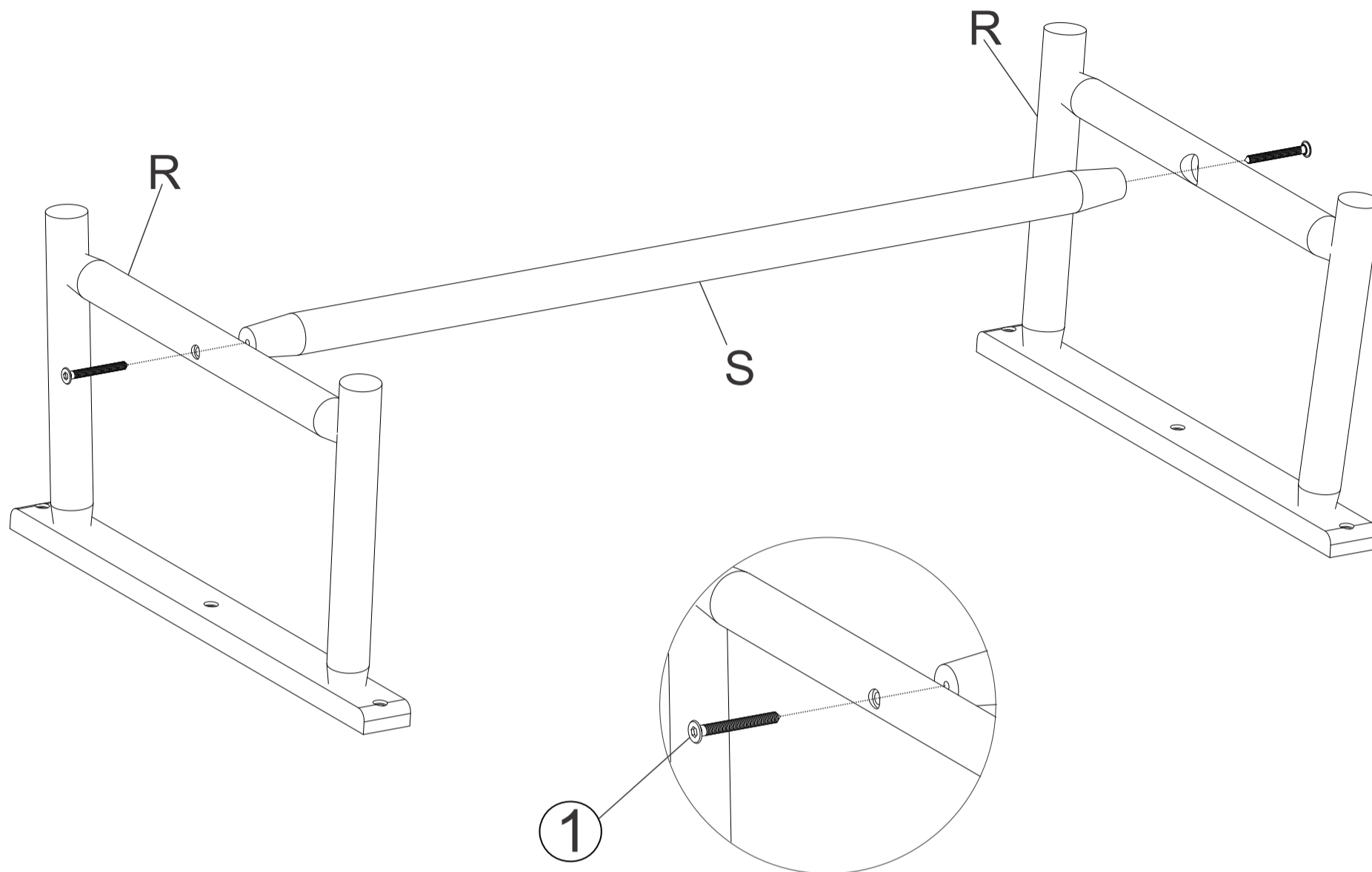

22

Tighten bolts

60%

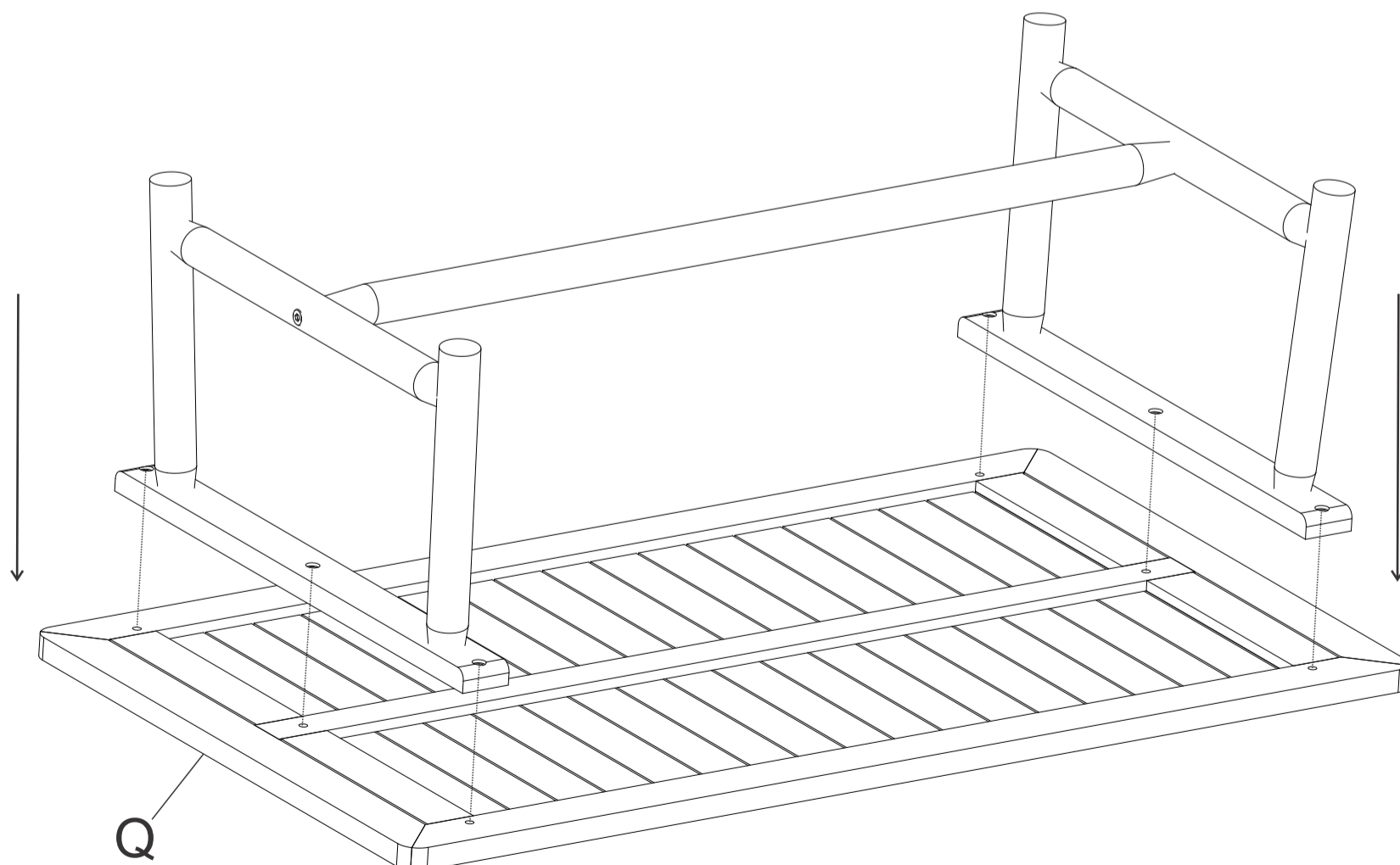

ASSEMBLY INSTRUCTION 18280008-09

23

Tighten bolts

100%

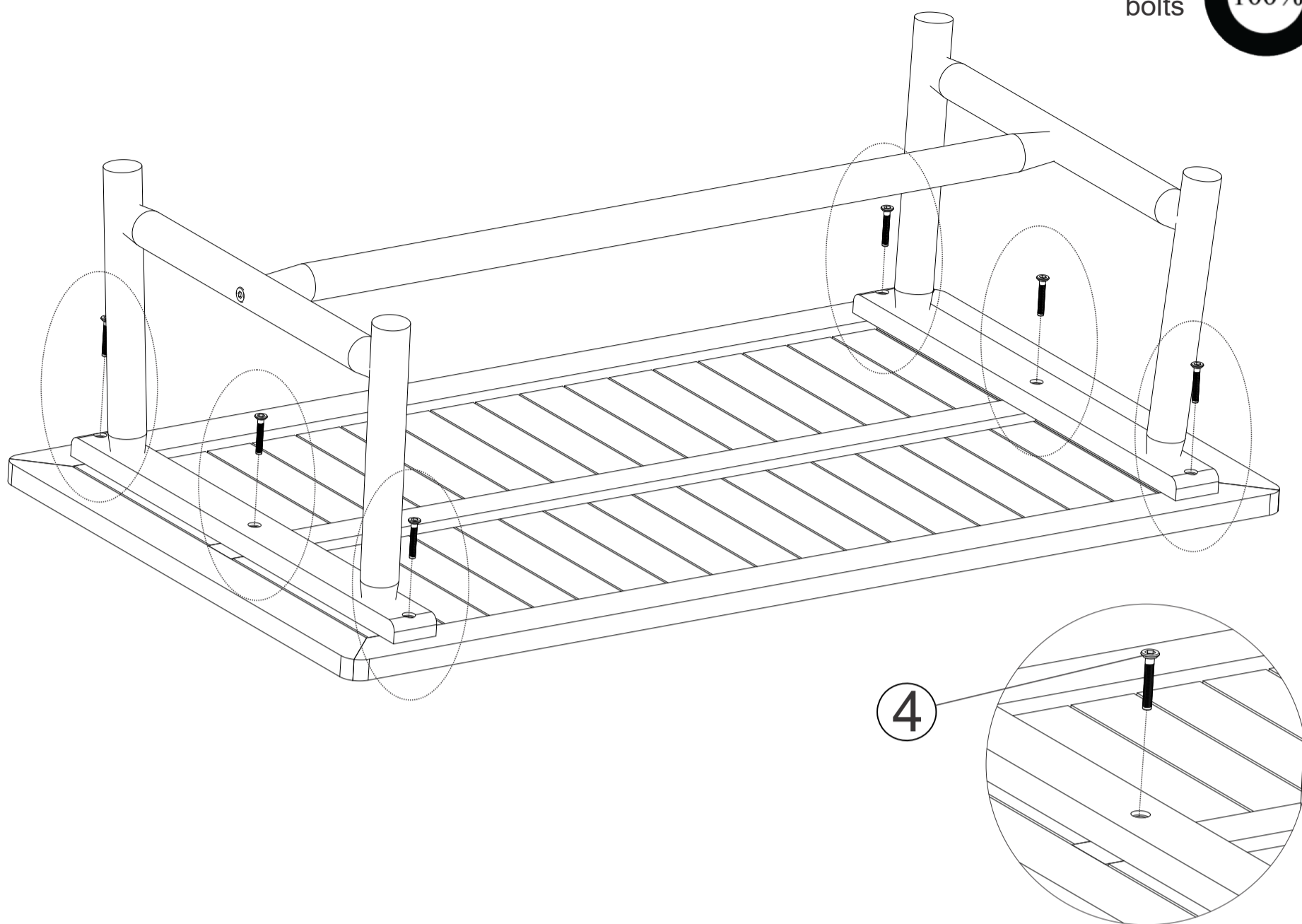

24

Tighten bolts

100%

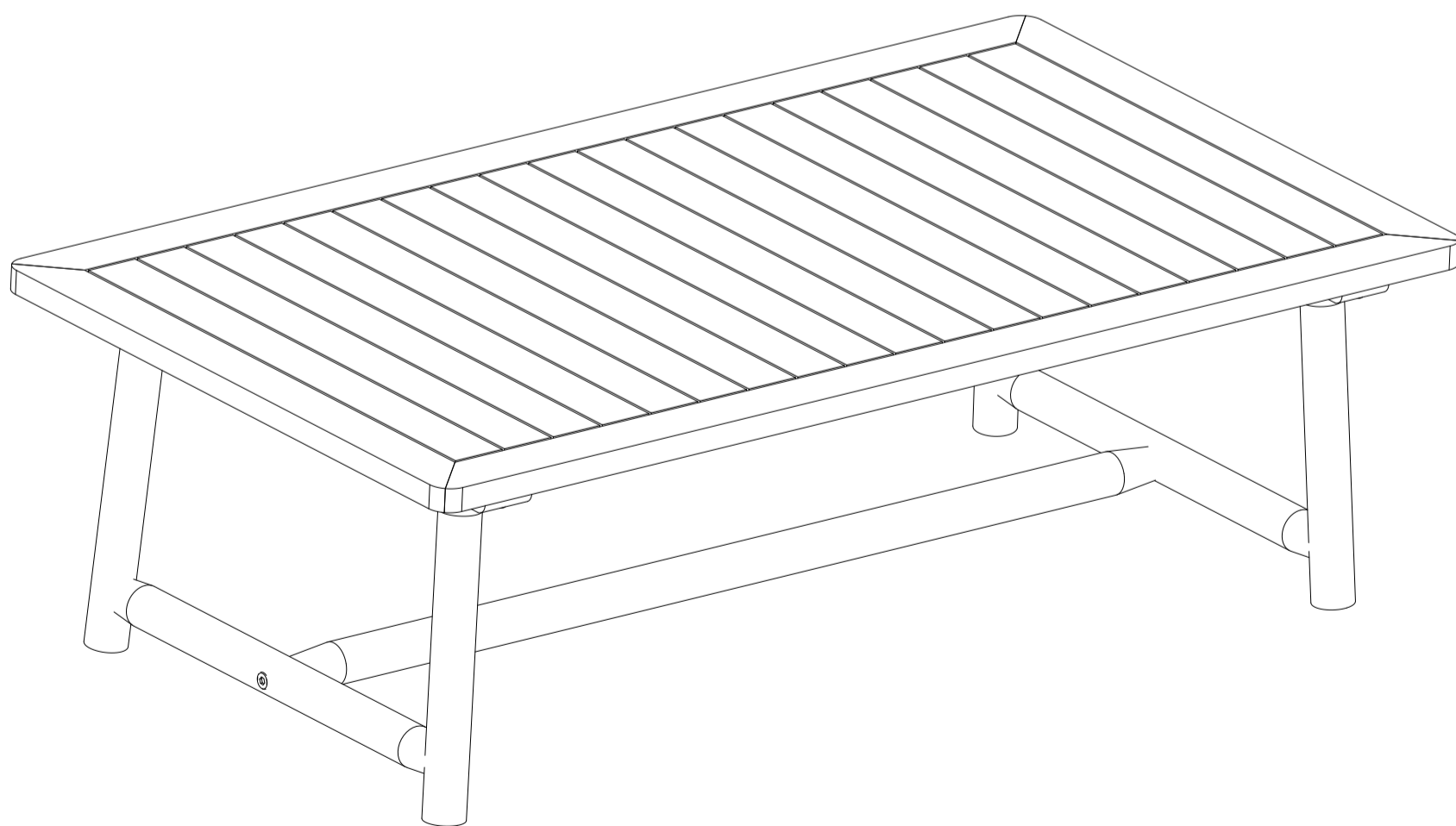

FINISHED.

