

# LINCOLN

# 5S MC LN 23

OPTION L

OPTION R

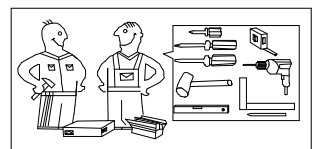
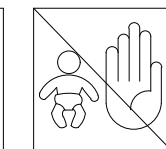
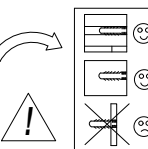
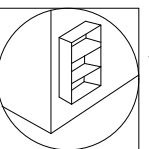
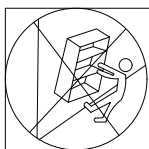
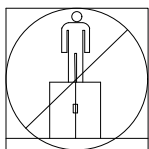
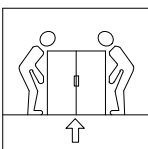
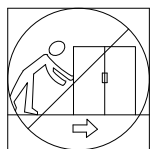
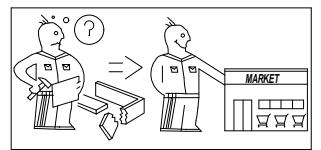
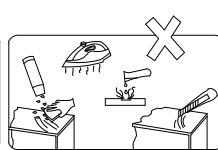
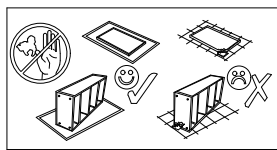
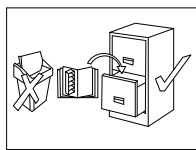
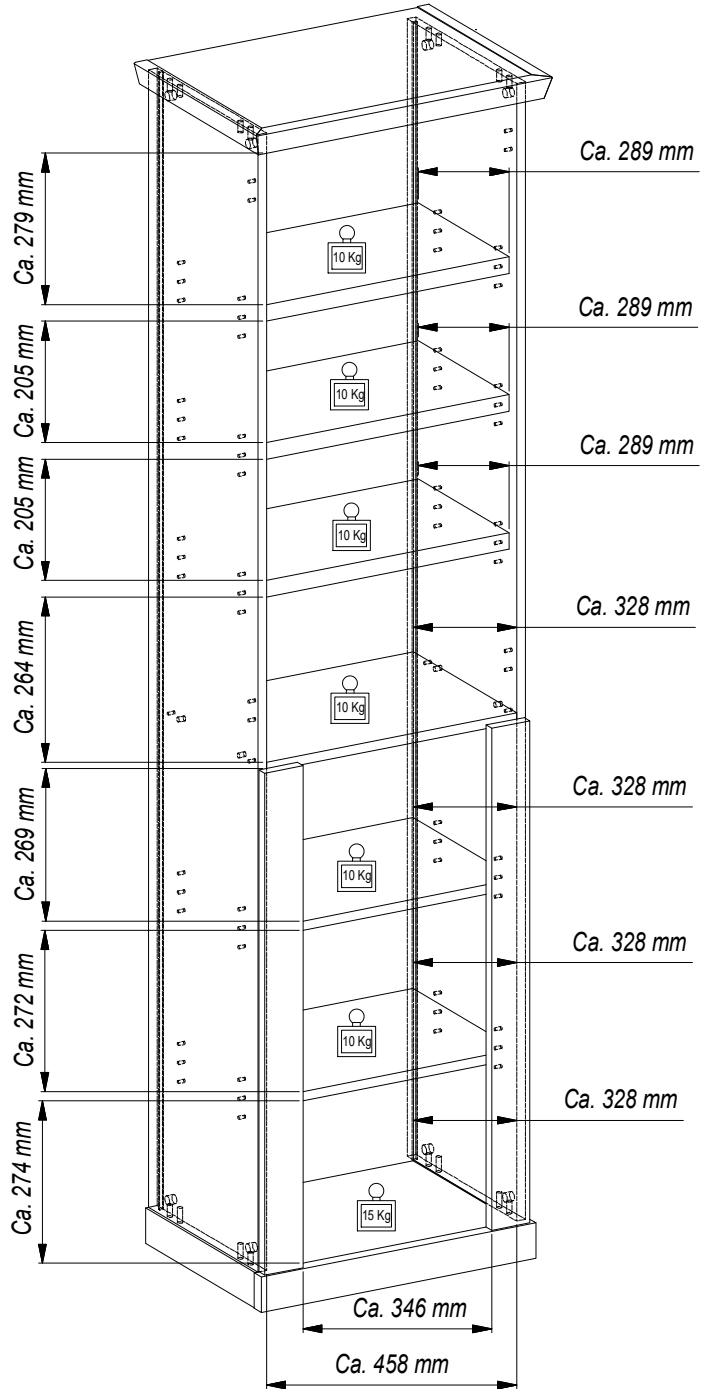
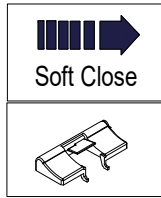
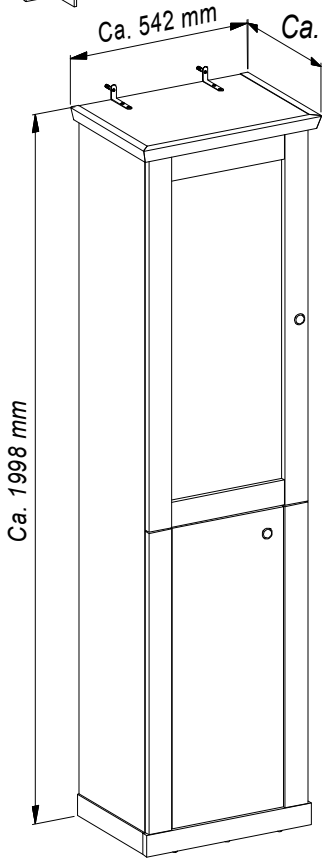
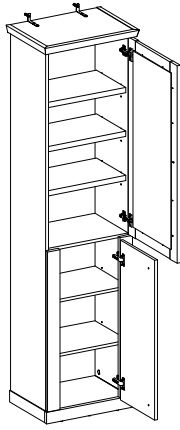
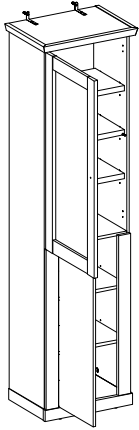

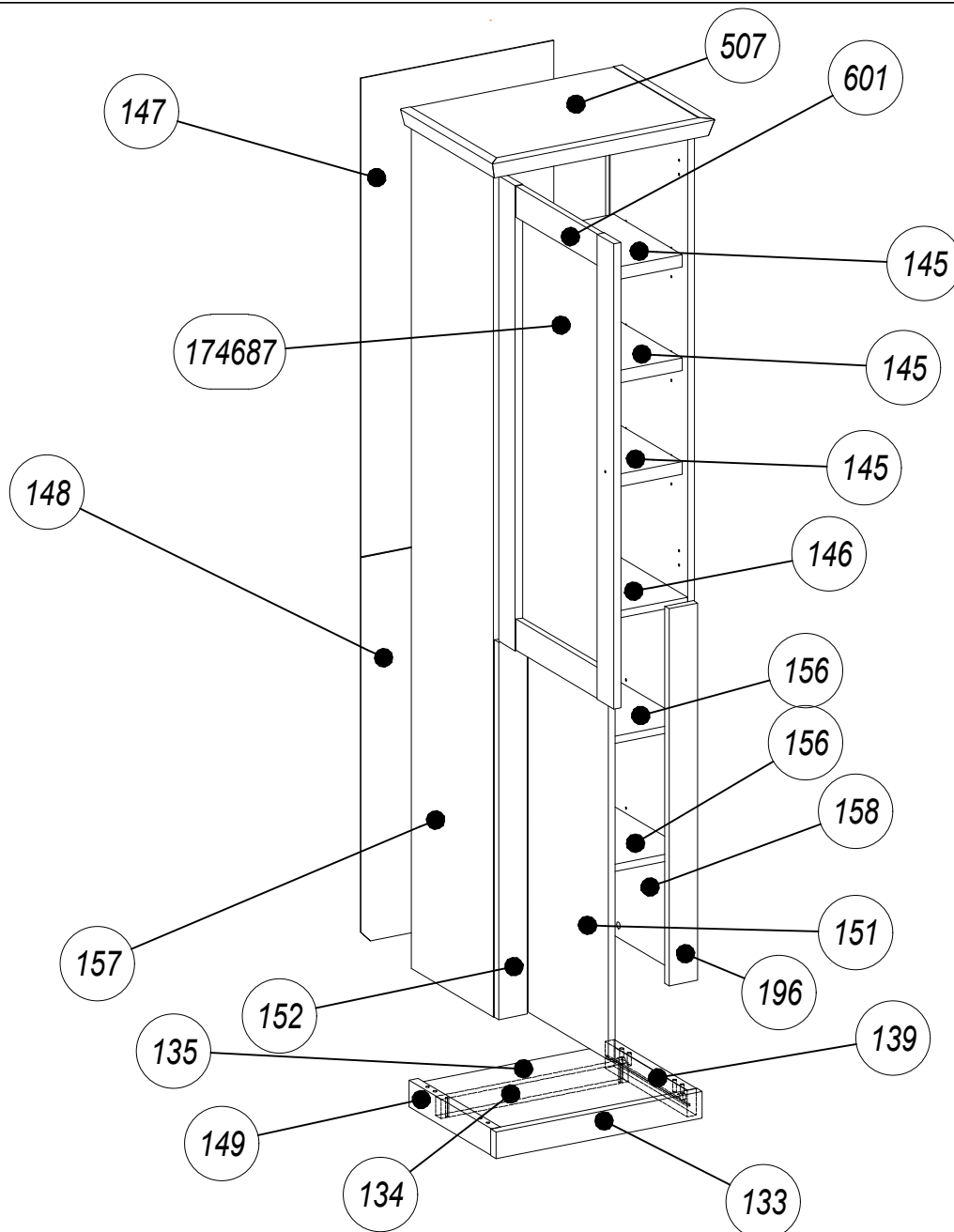

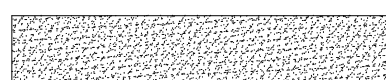
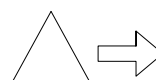
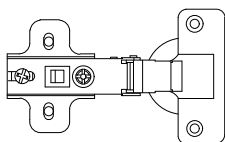
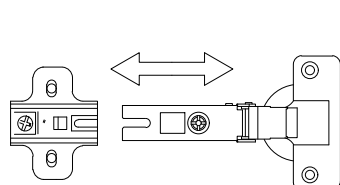
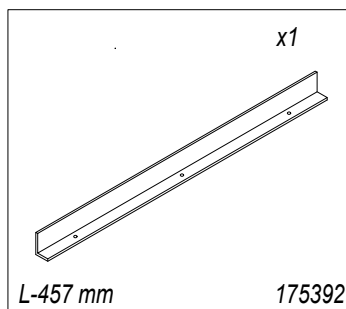
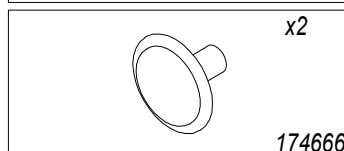
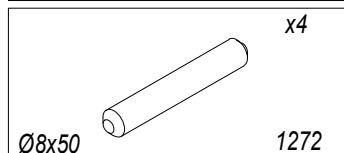
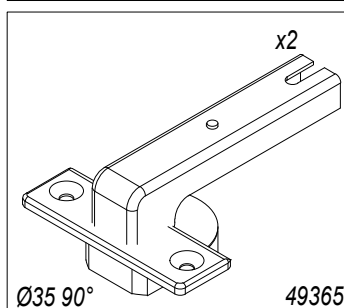
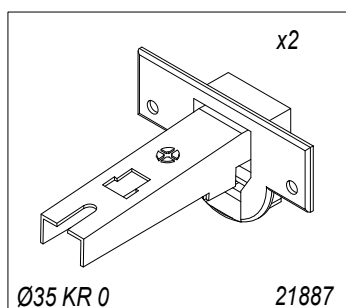
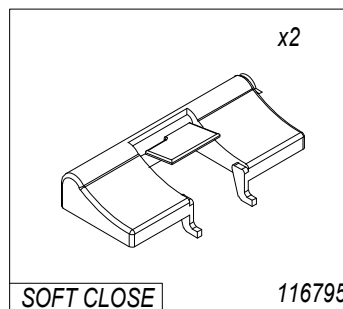
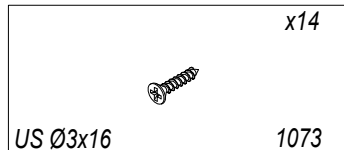
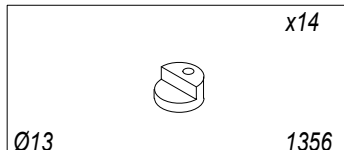
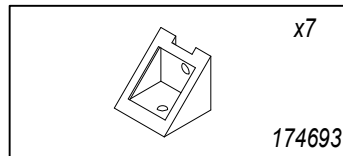
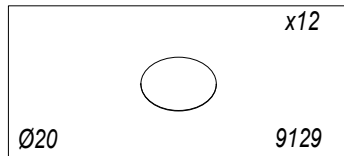
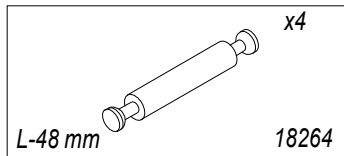
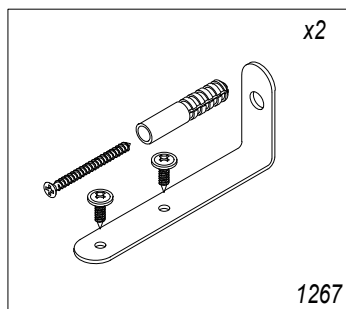
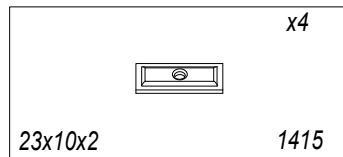
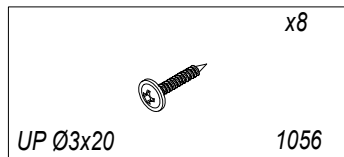
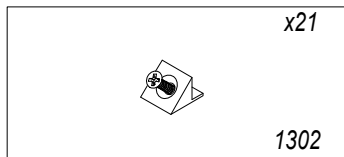
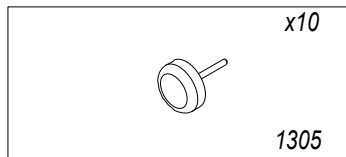
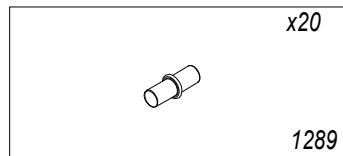
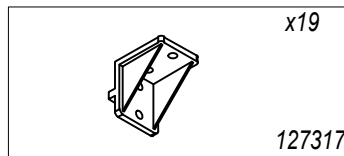
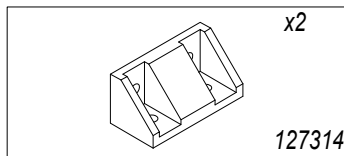
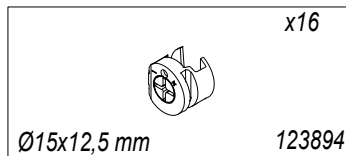
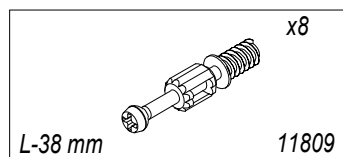
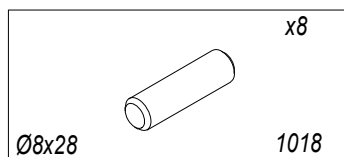
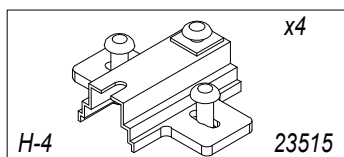
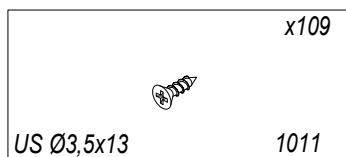

AI No.	QTY	H	W	D	PKG
133	1	503	60	22	1/2
134	1	456	43	22	1/2
135	1	456	327	16	1/2
139	1	347	60	22	1/2
145	3	457	288	28	1/2
146	1	458	327	16	1/2
147	1	1076	470	2,5	2/2
148	1	865	470	2,5	2/2
149	1	347	60	22	1/2
151	1	845	340	16	2/2
152	1	848	70	18	2/2
156	2	457	327	16	1/2
157	1	1921	347	16	2/2
158	1	1921	347	16	2/2
174687	1	934	376	4	2/2
196	1	848	70	18	2/2
507	1	542	388	38	1/2
601	1	486	1046	18	2/2



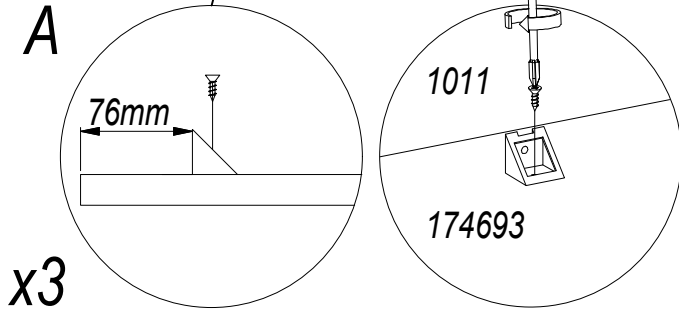
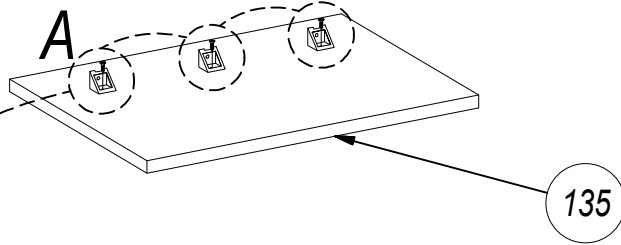

1

 174693 x3	 US Ø3,5x13 1011 x3
--------------------------------------------------------------------------------------------------	---------------------------------------------------------------------------------------------------------------



2

 30x30x3 127317 x2	 US Ø3,5x13 1011 x4
----------------------------------------------------------------------------------------------------------------	-----------------------------------------------------------------------------------------------------------------

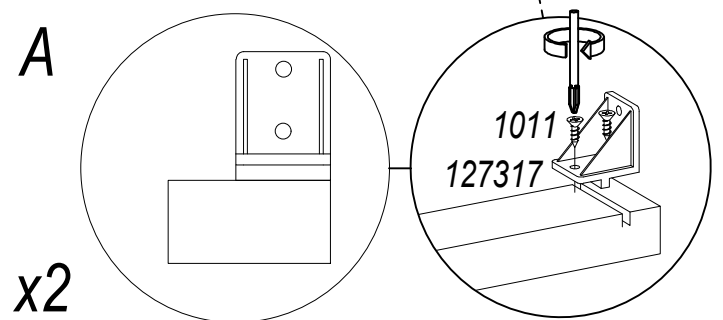
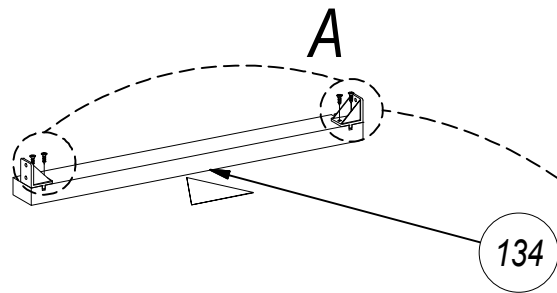

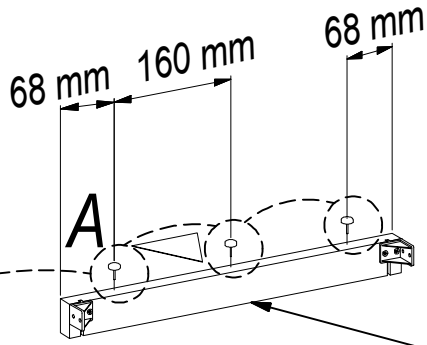
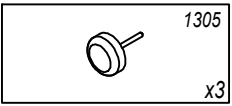

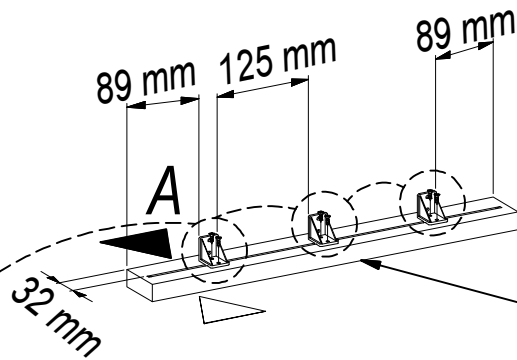
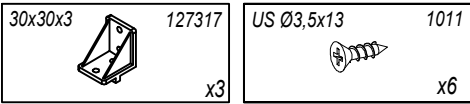
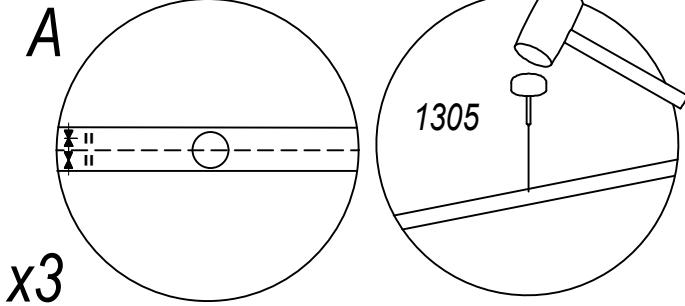

134



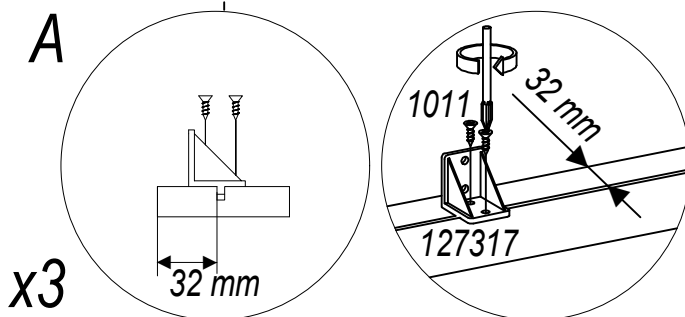

133

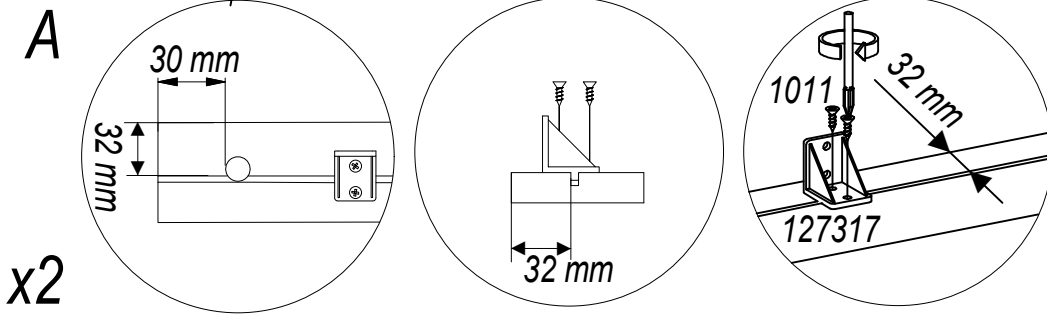
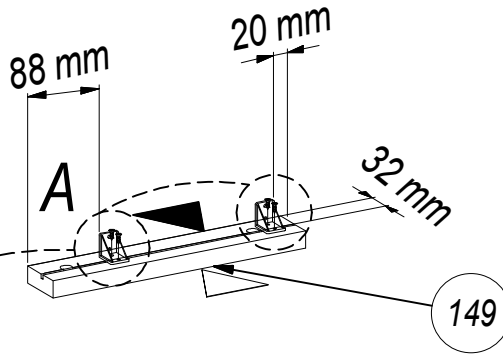

30x30x3	127317	US Ø3,5x13	1011
	x2		x4

5



127314	US Ø3,5x13	1011	
	x1		x2

6

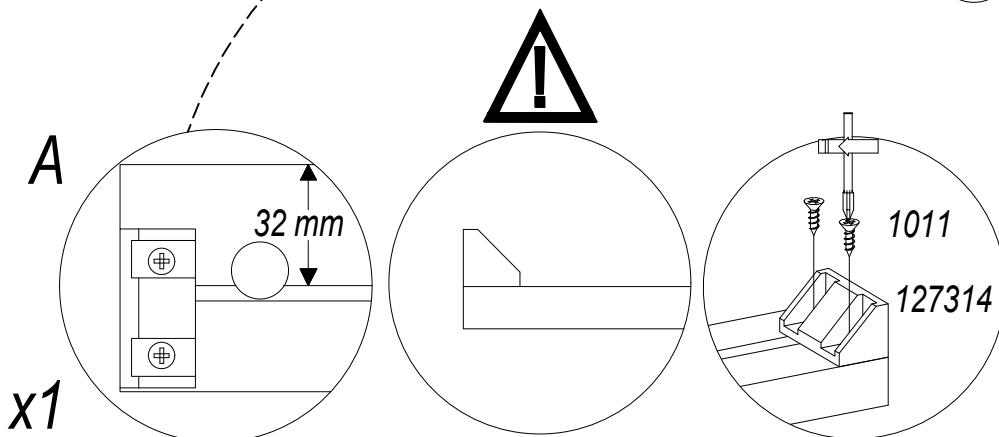
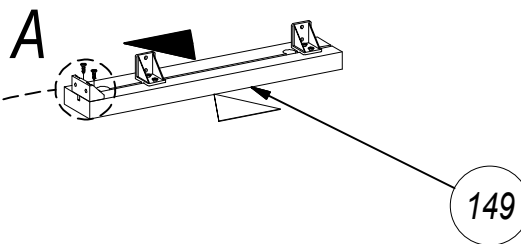

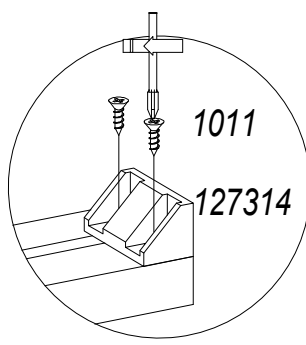
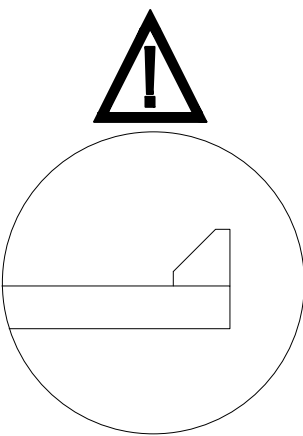
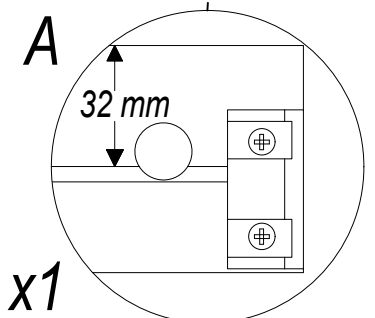
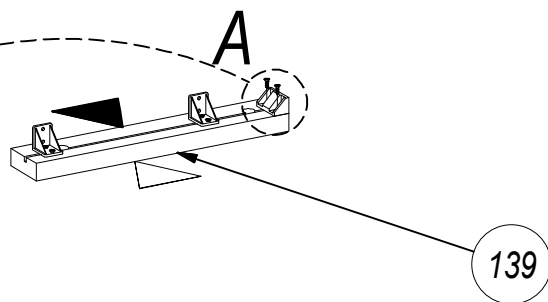
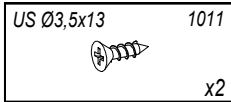
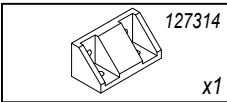
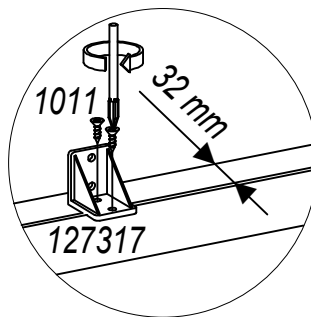
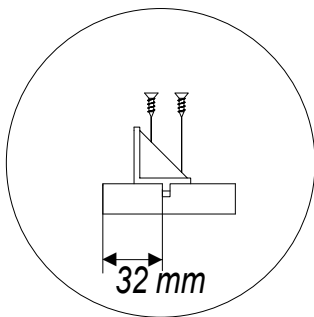
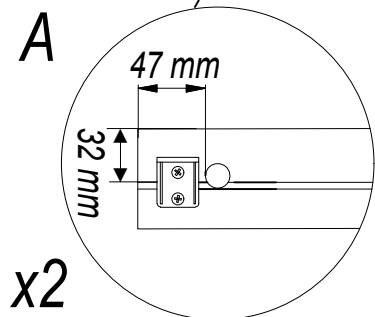
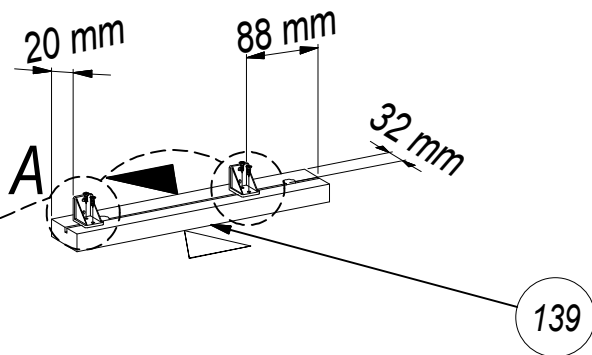
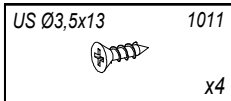
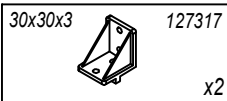

US Ø3,5x13 1011  
x8

9

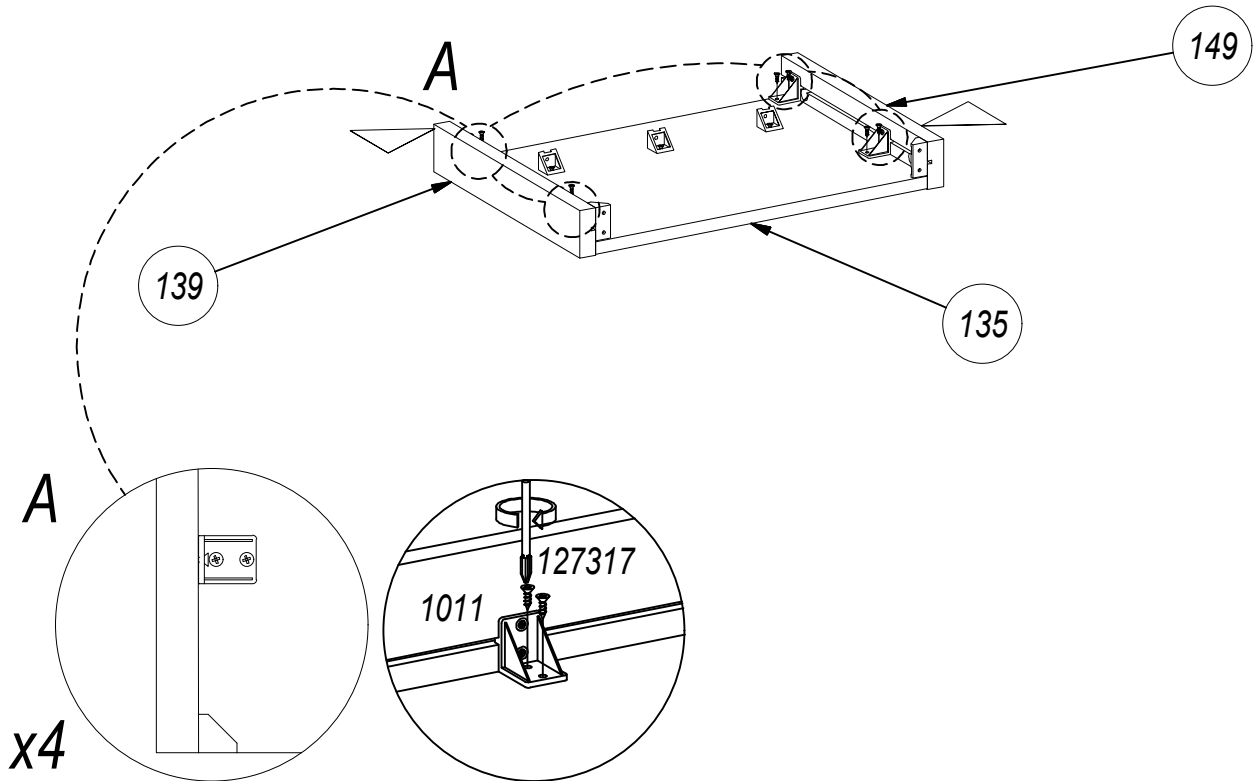

US Ø3,5x13 1011  
x7

10

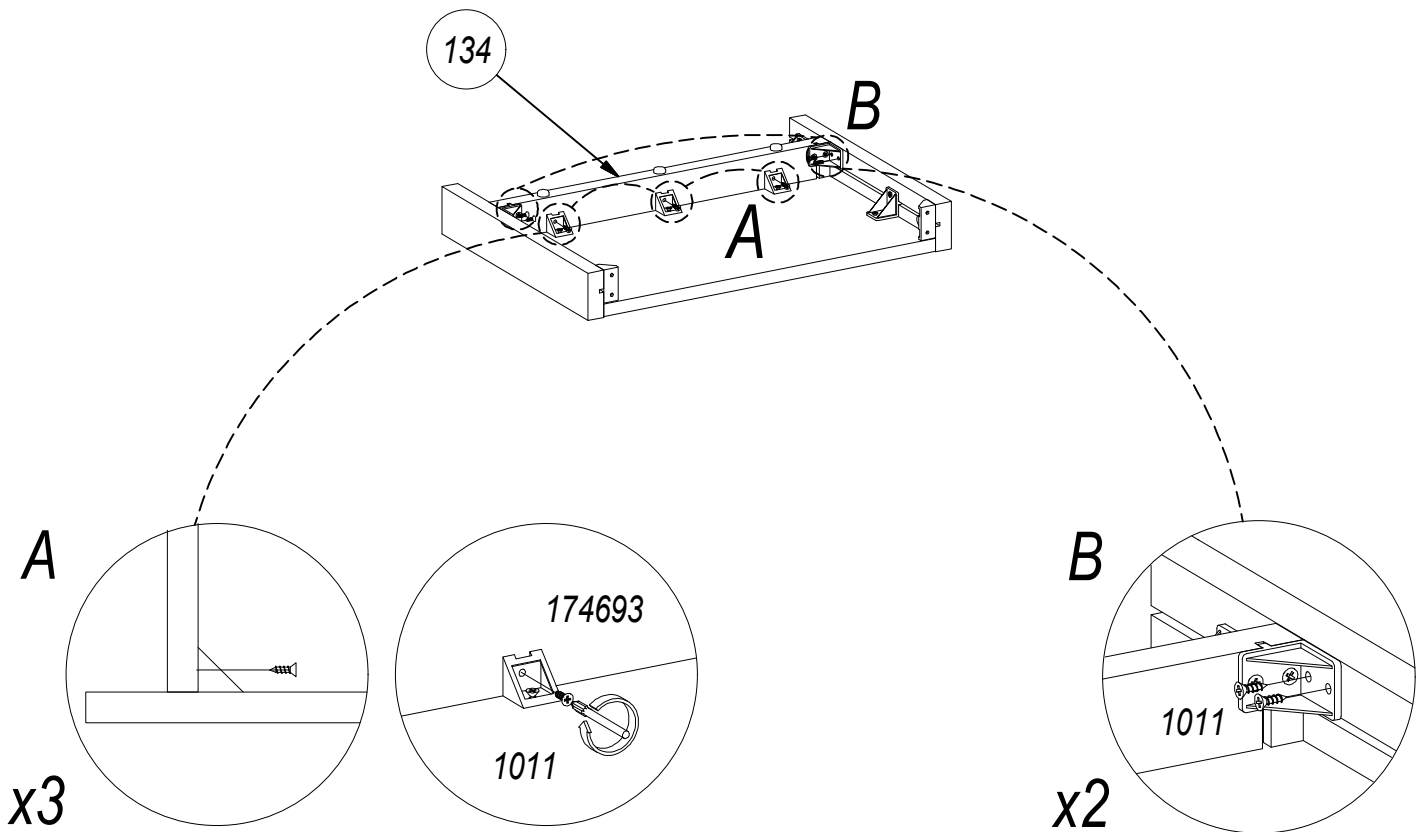

US Ø3,5x13 1011  
  
 x10

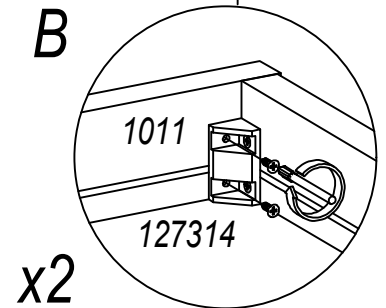
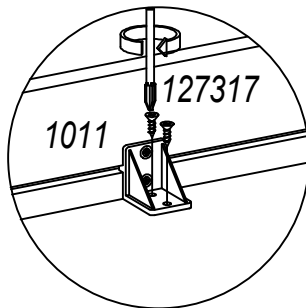
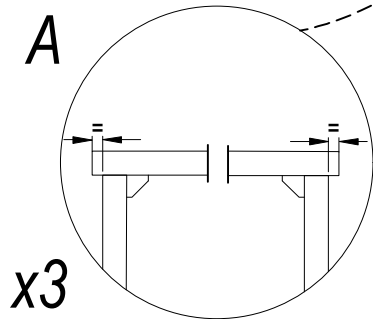
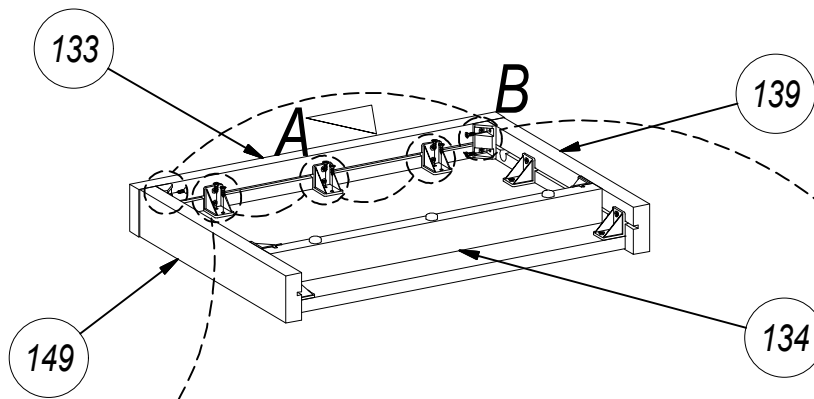

11



1305  
  
 x7

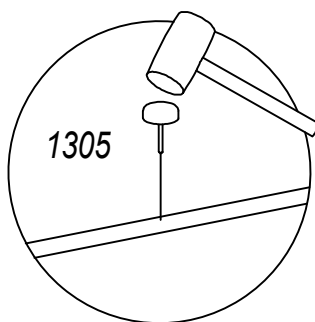
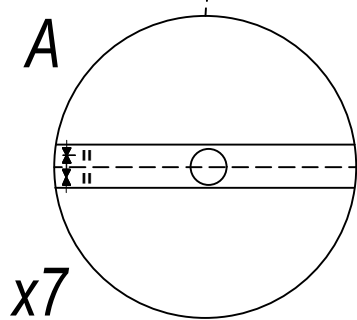
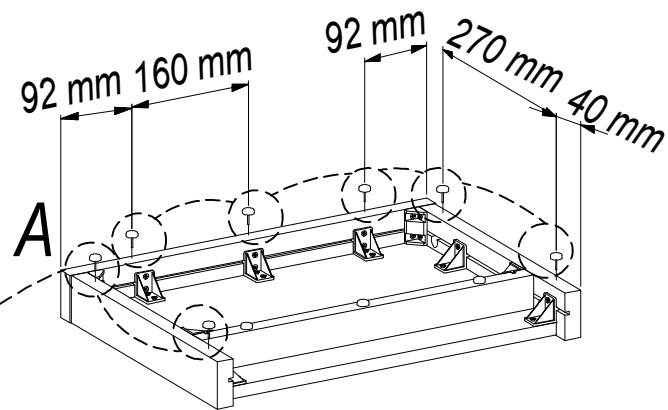

12

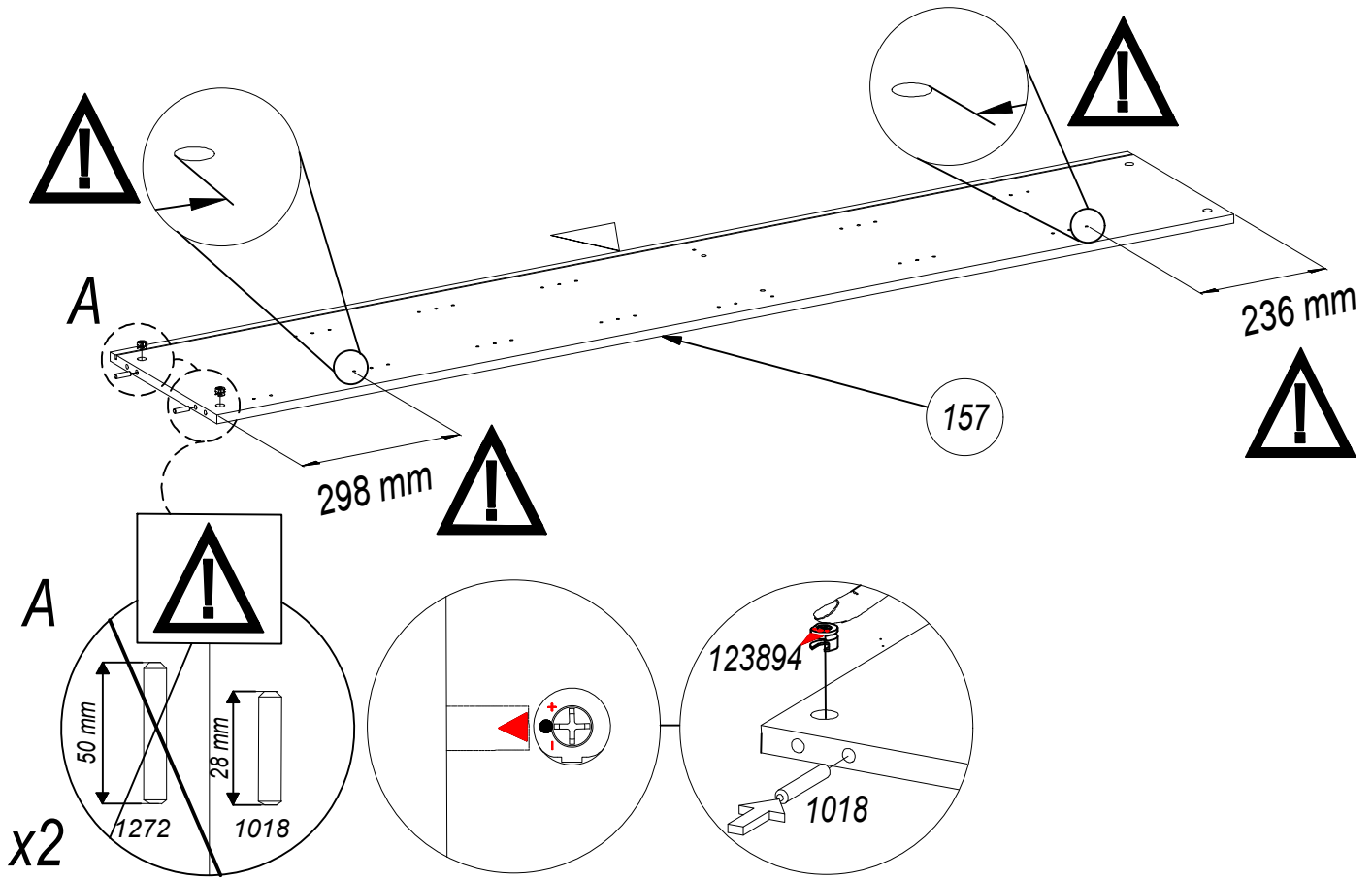

$\varnothing 8 \times 28$	1018	$\varnothing 15 \times 12,5$	123894
	x2		x2

13



L-38 mm	11809	$\varnothing 8 \times 50$	1272
	x2		x2

14

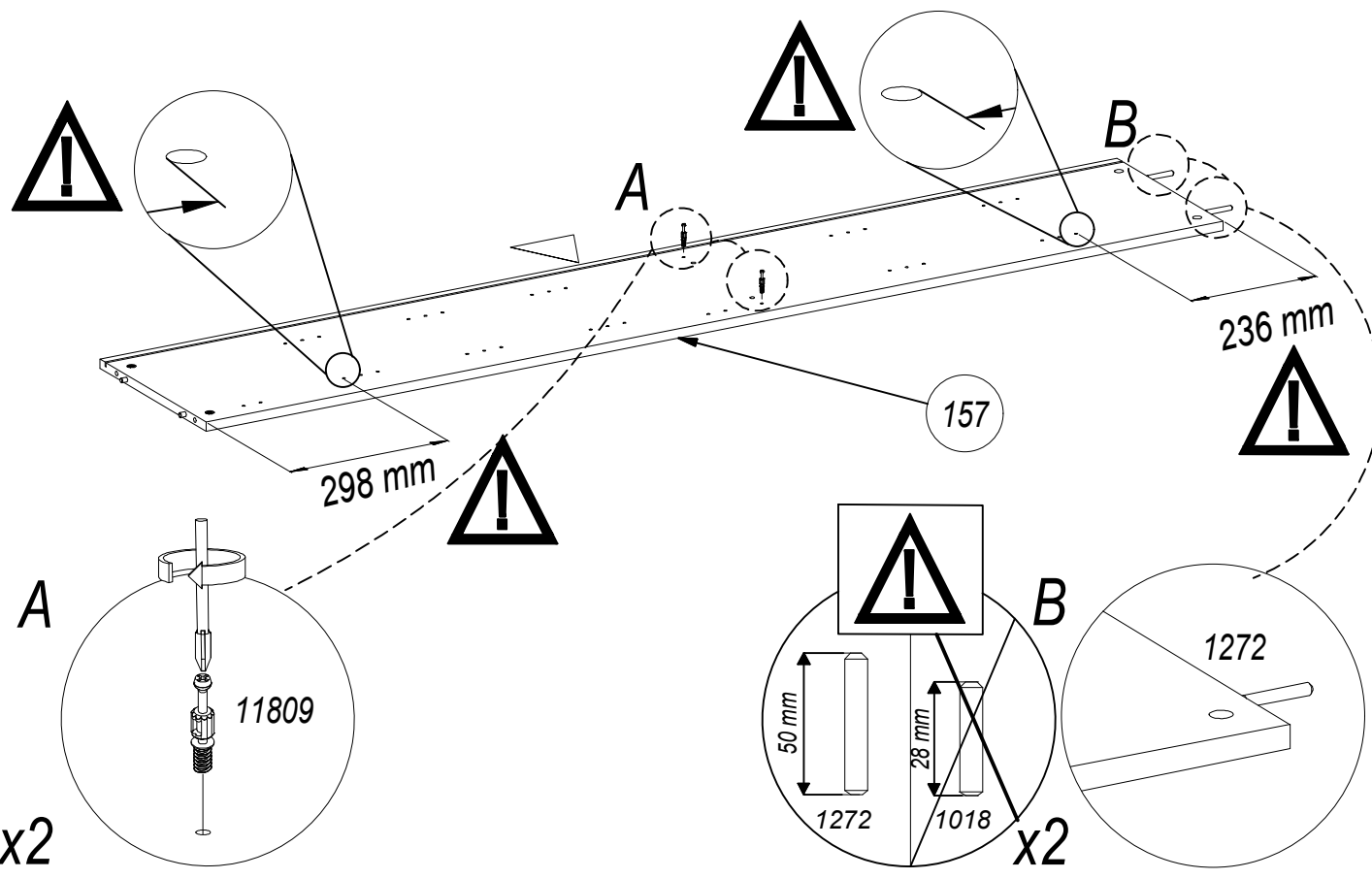

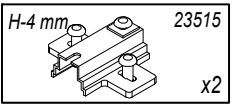

OPTION L

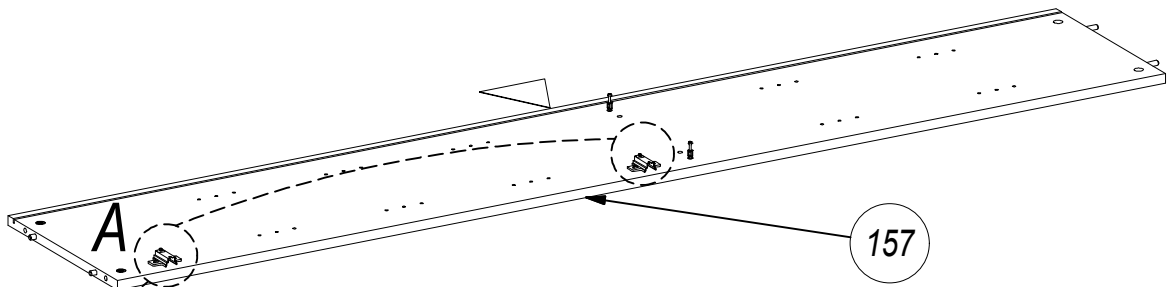
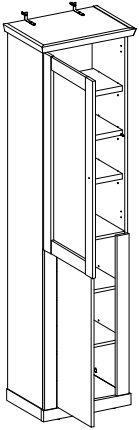

A

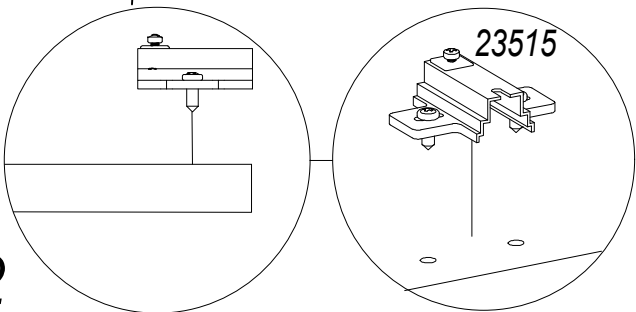

x2

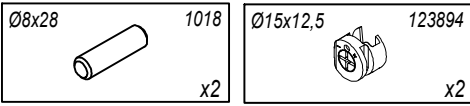

15

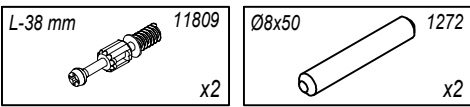
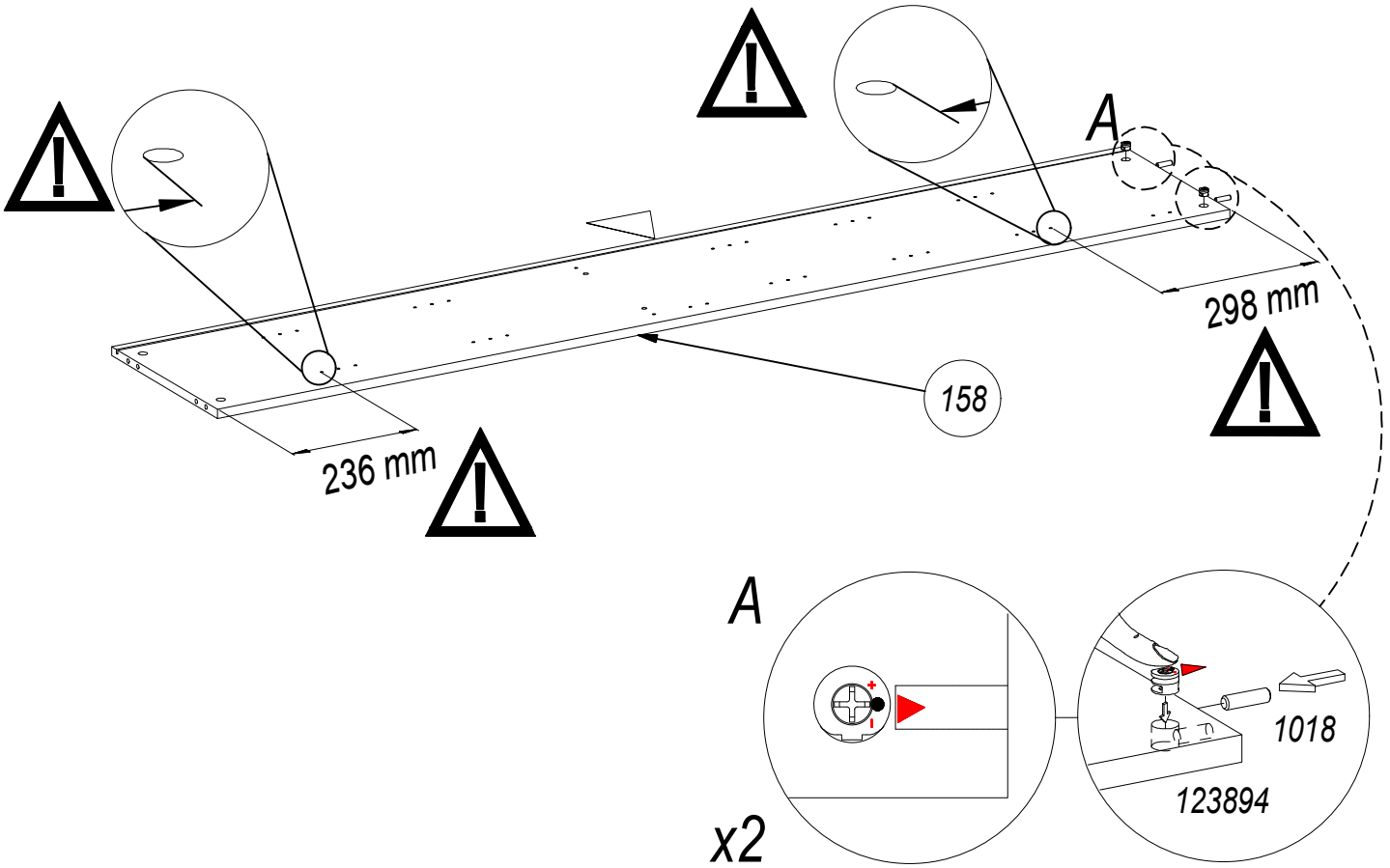

16

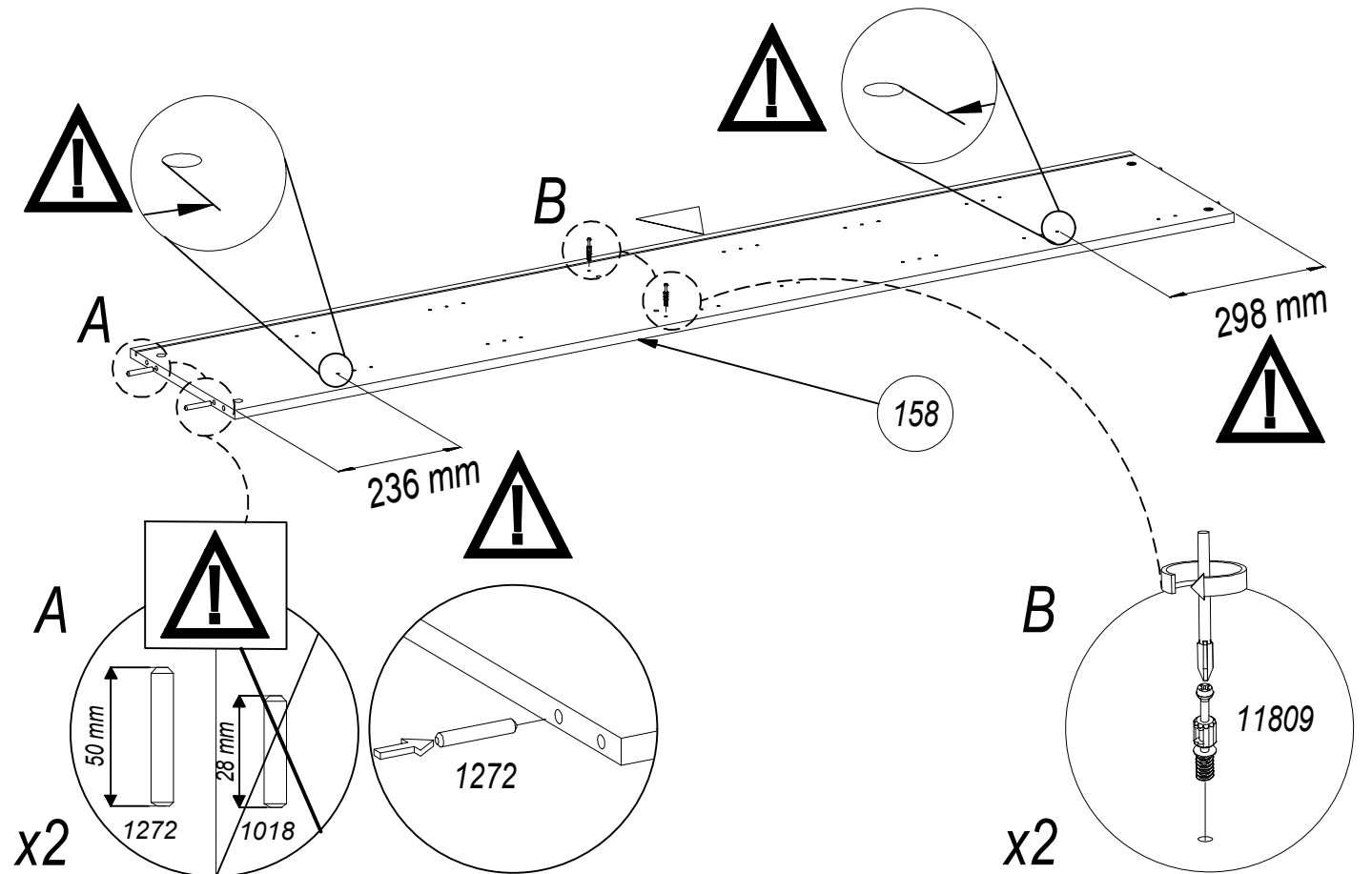

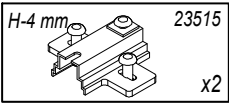

OPTION R

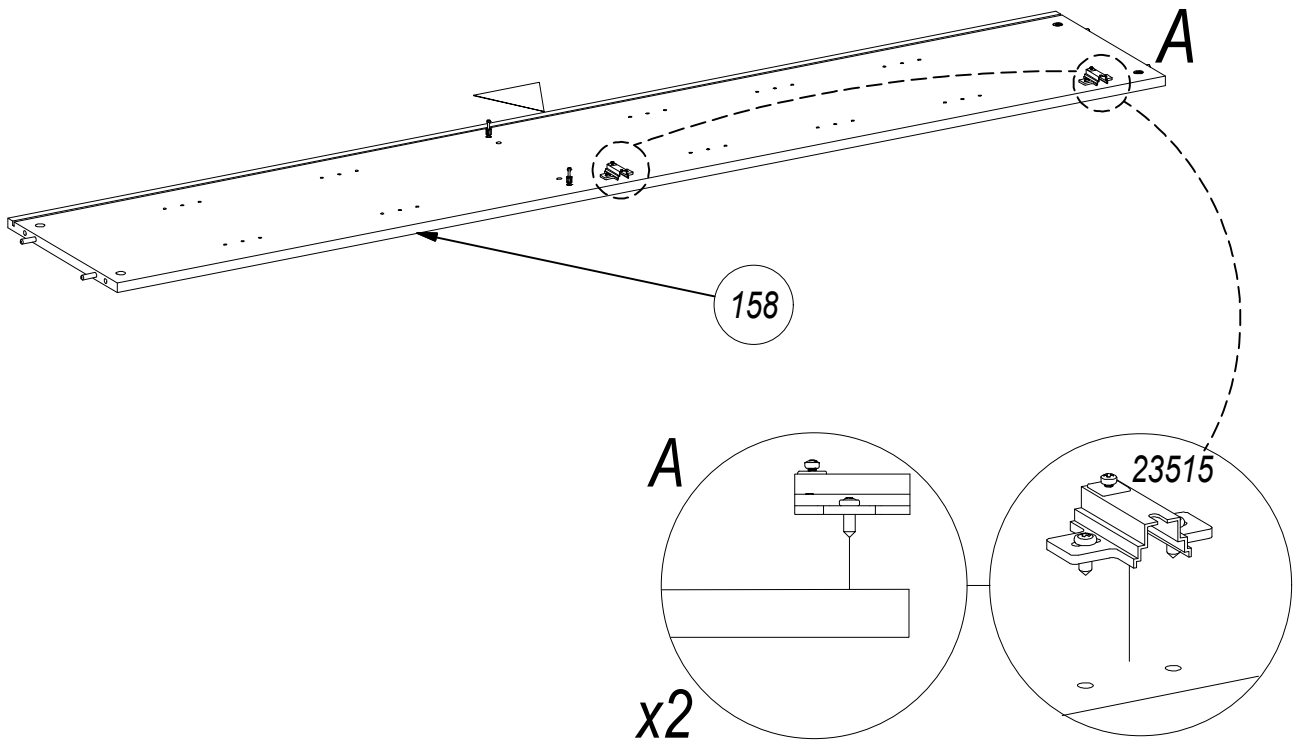
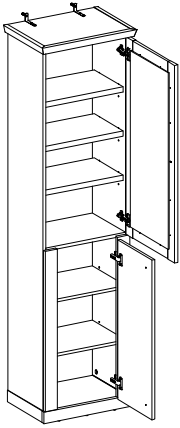

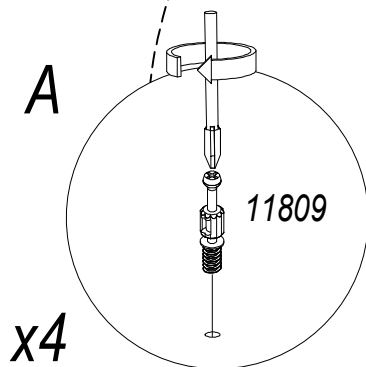
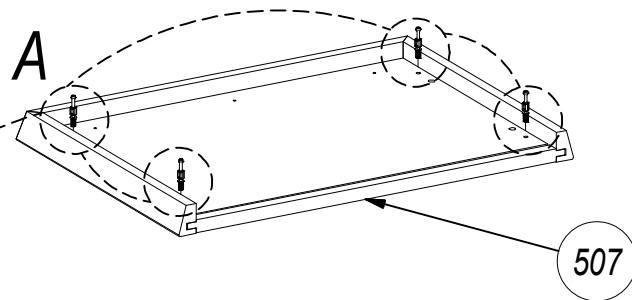
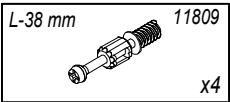
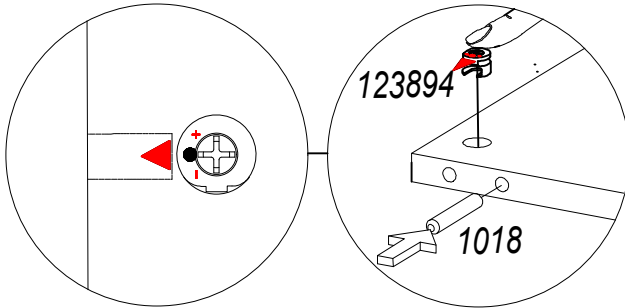
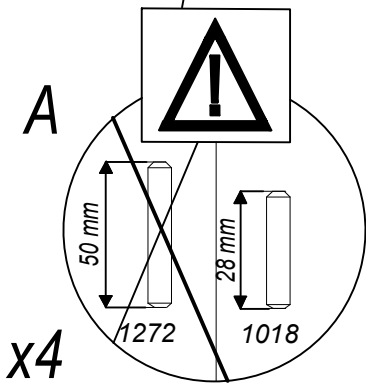
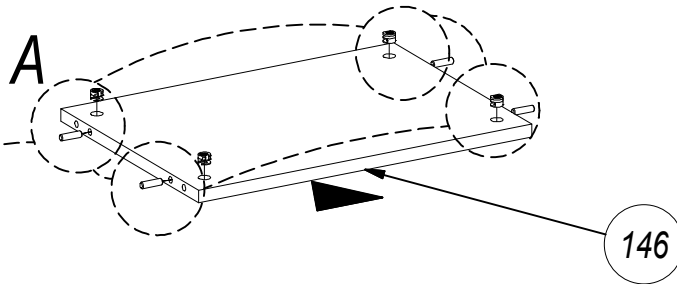
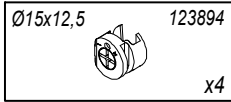
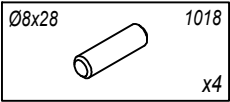

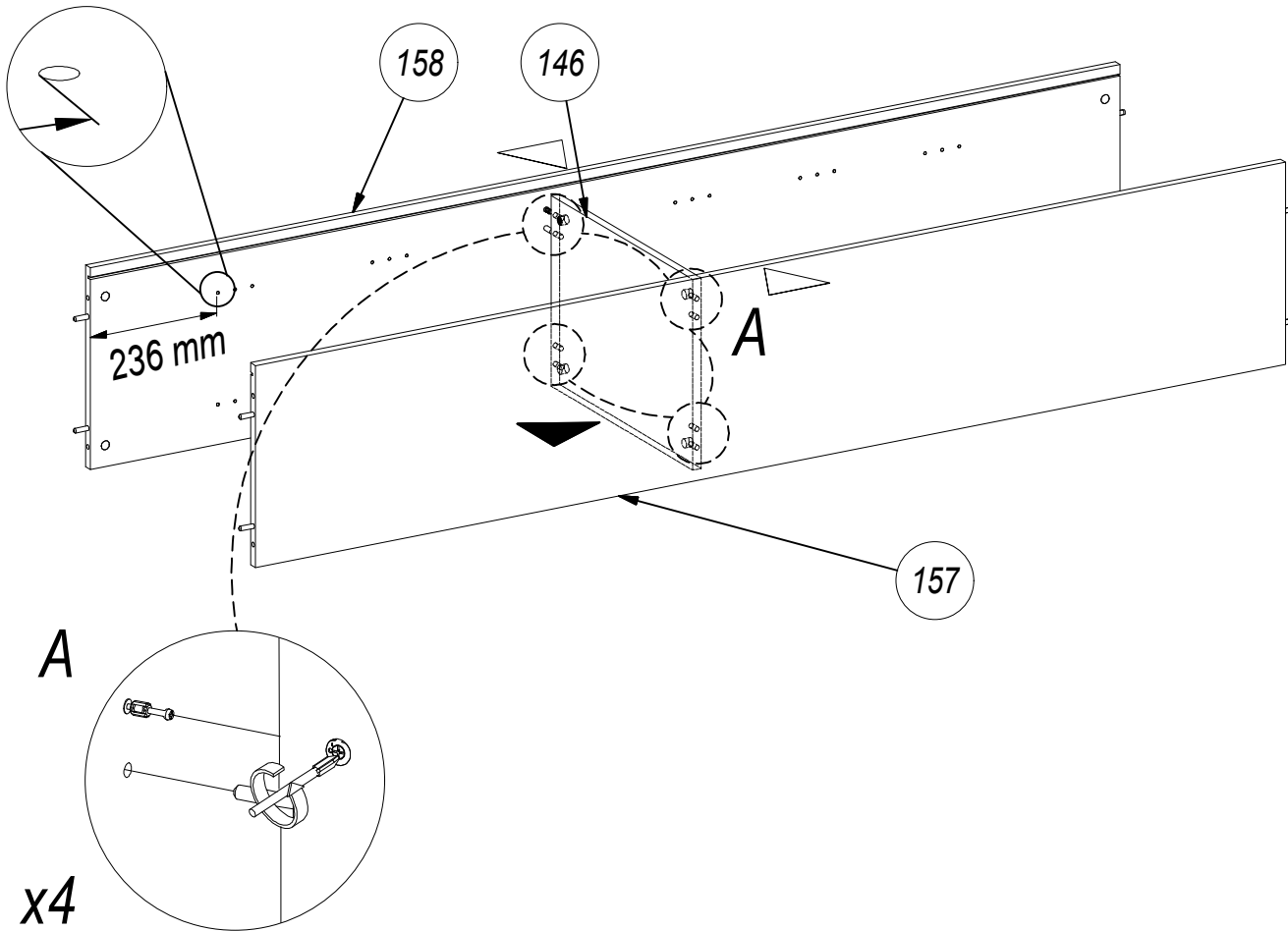

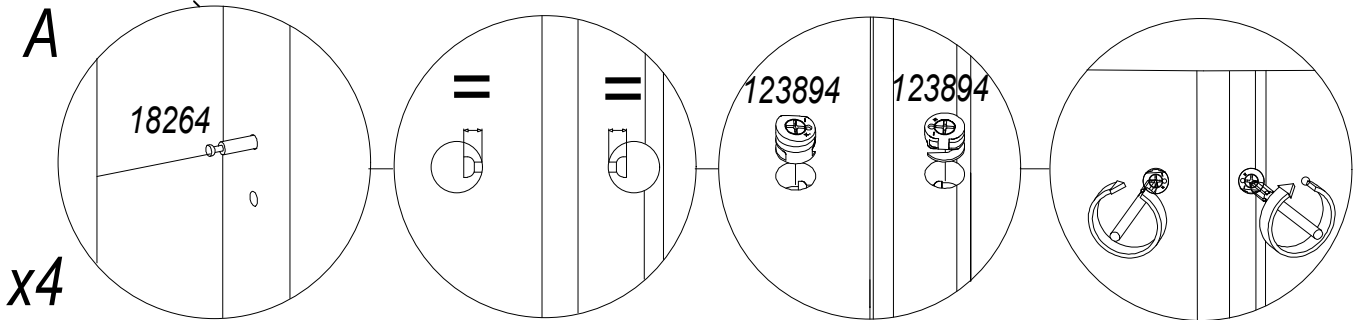
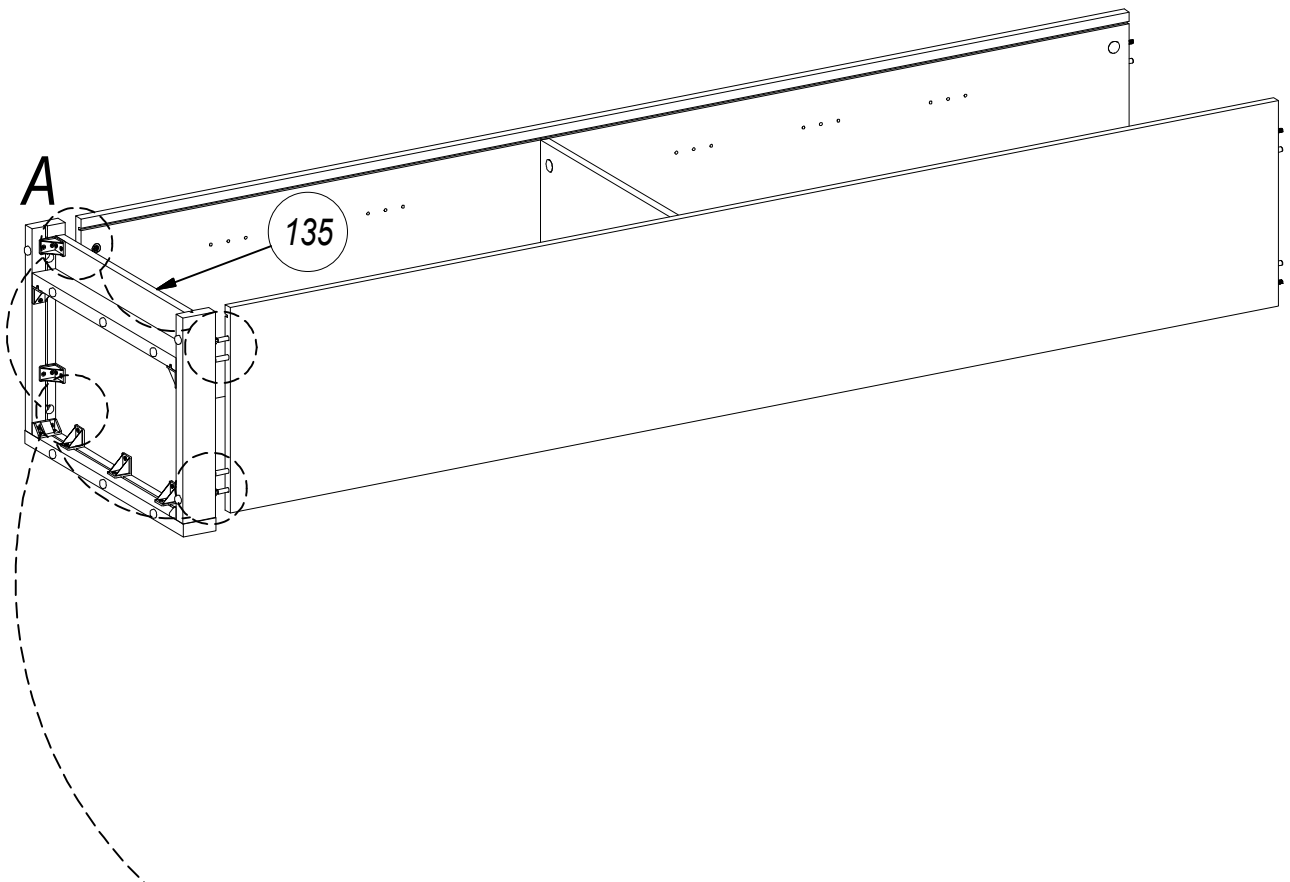
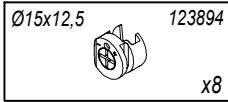
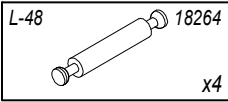

22

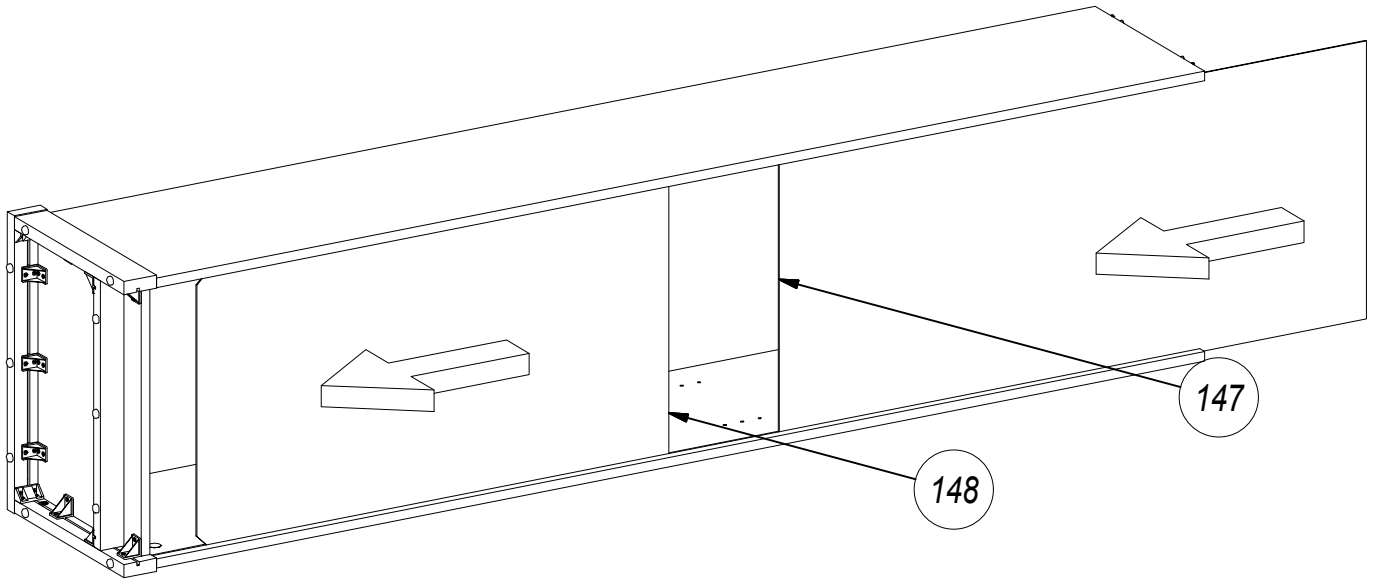

23

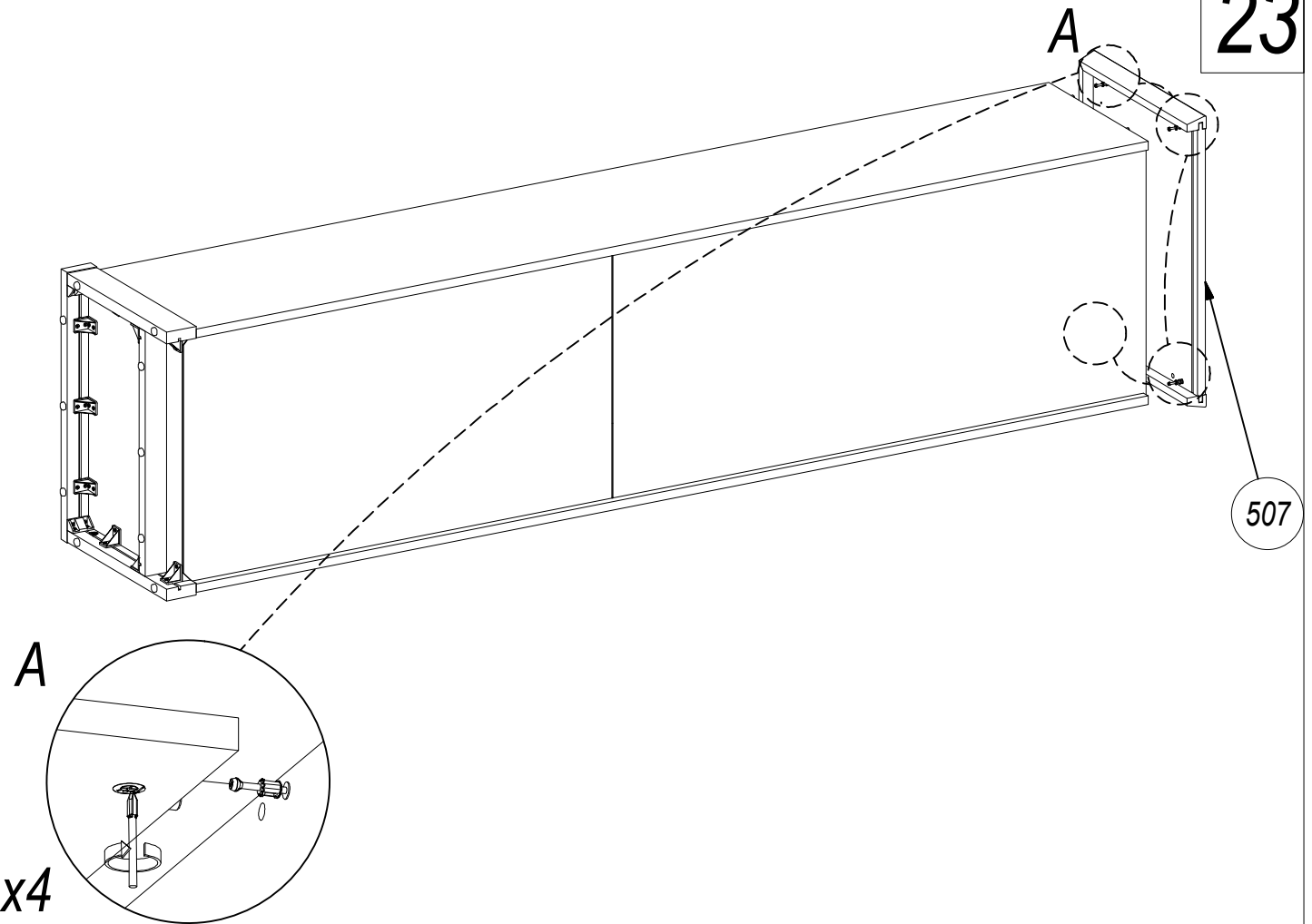

23x10x2 mm 1415  
x4

UP Ø3x20 mm 1056  
x4

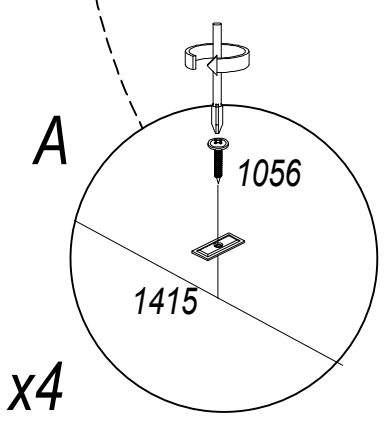
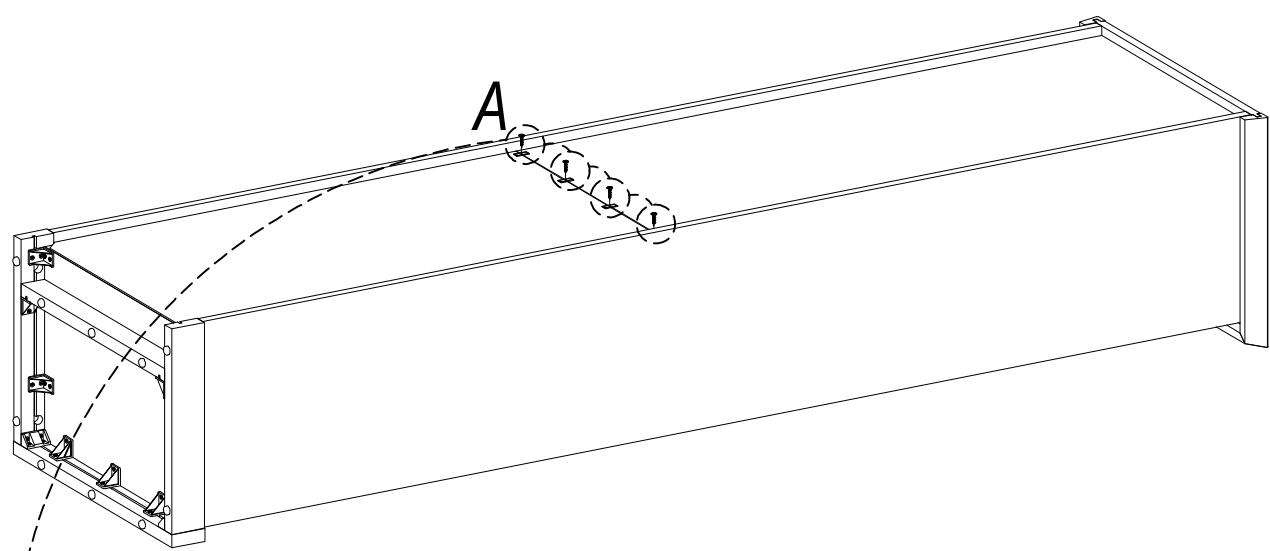
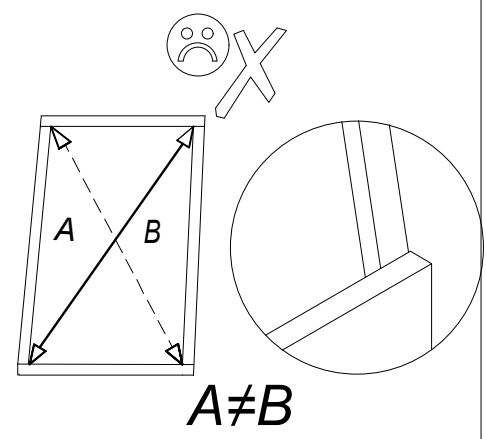
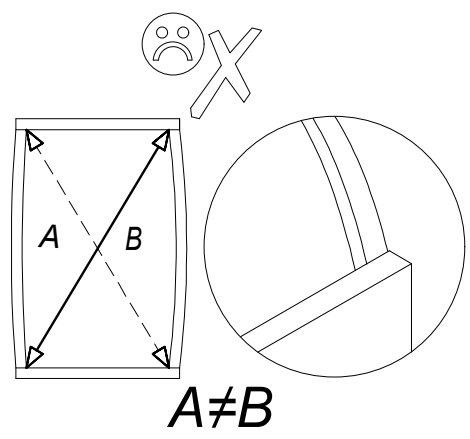
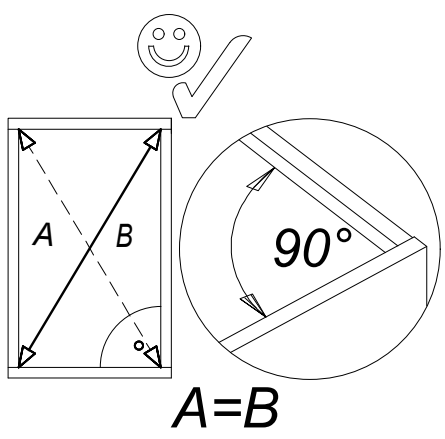

UP Ø3x20 mm 1056  
x4

25

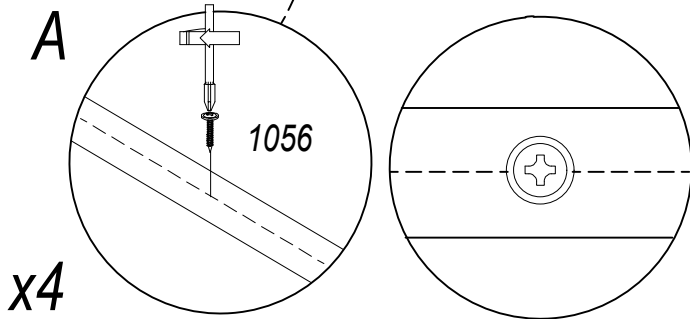
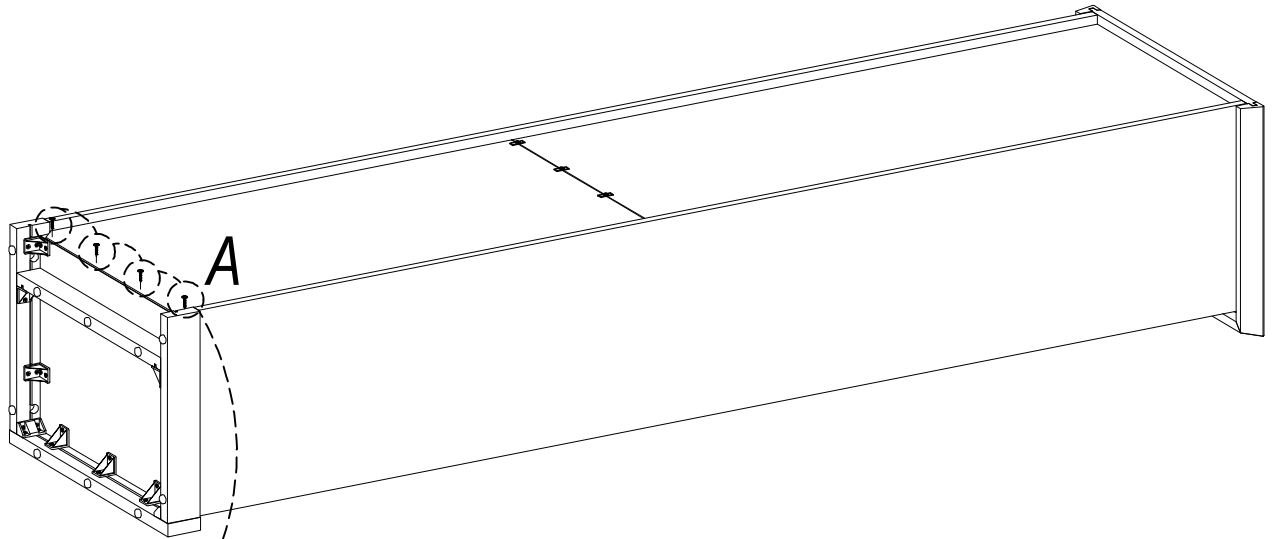

1302  
x21

26

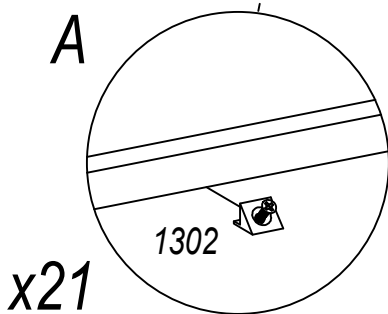
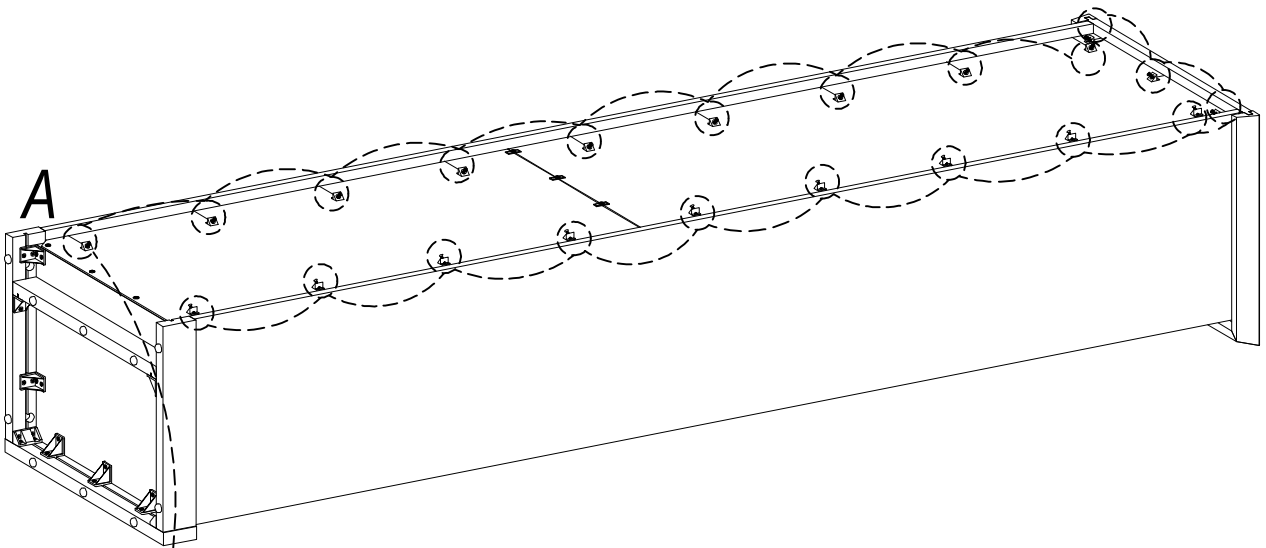

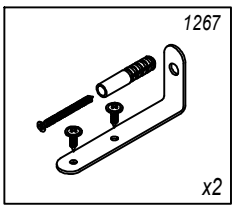

OPTION L

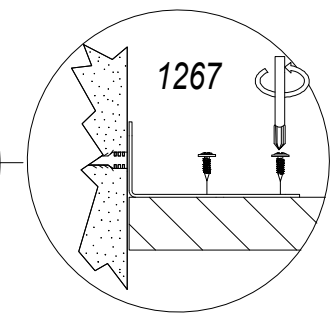
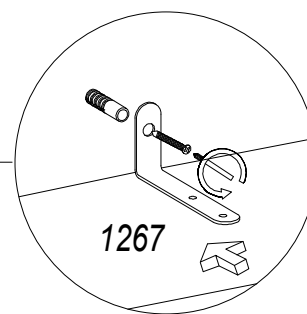
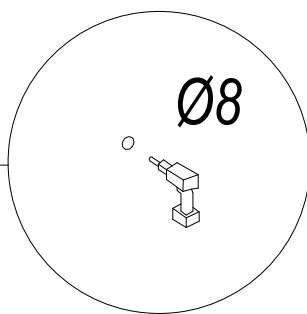
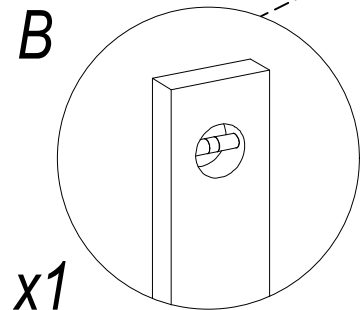
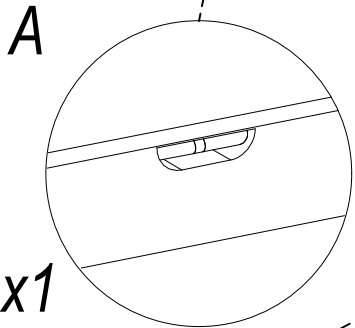
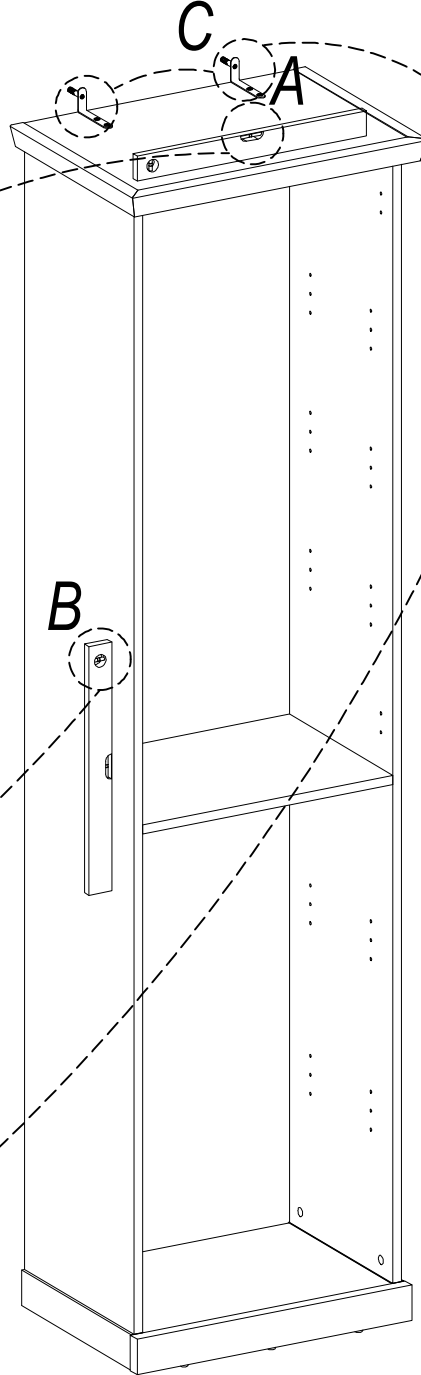
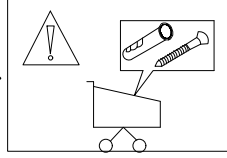
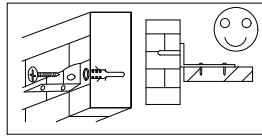
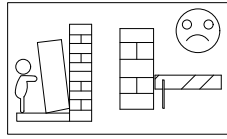
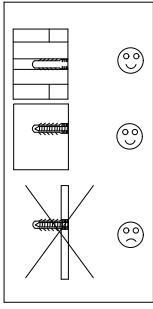
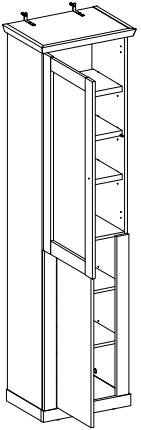

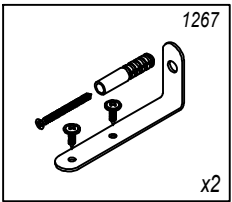

OPTION R

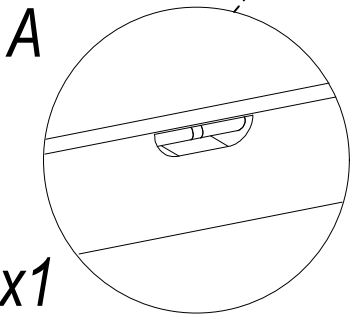
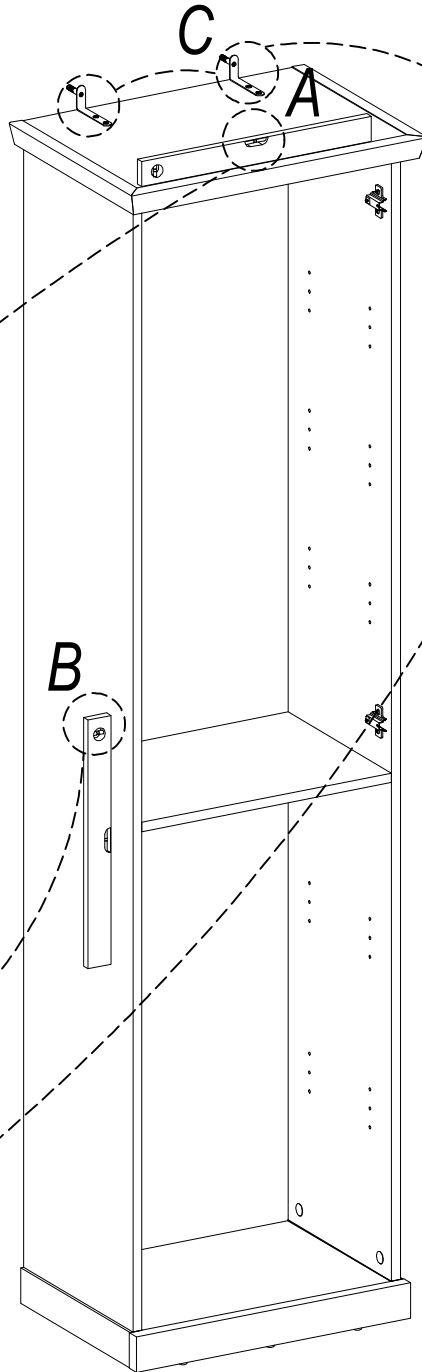
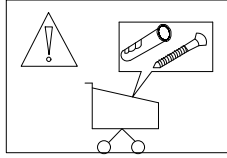
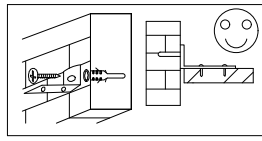
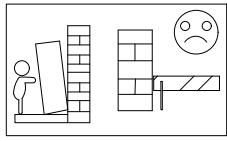
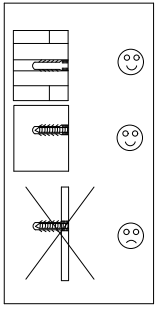
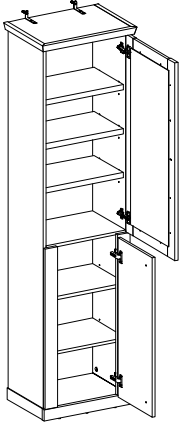

x1

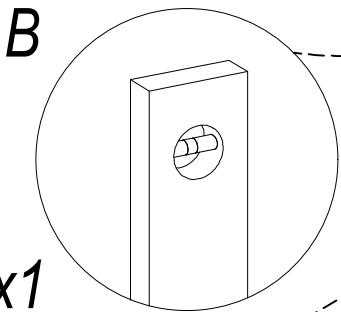

x1

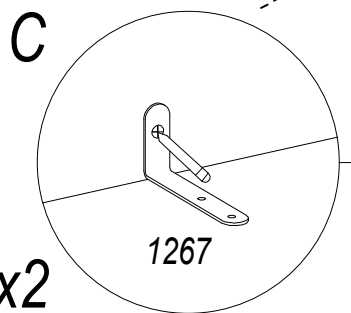

x2

1267

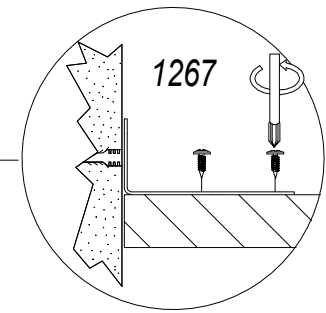
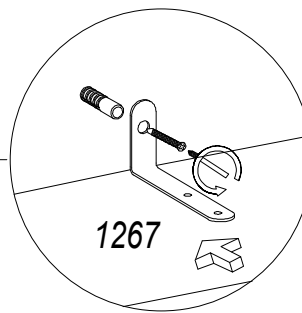
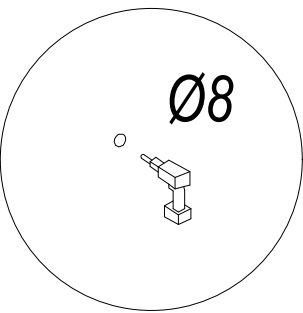

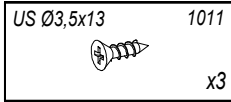
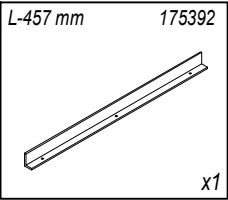

OPTION L

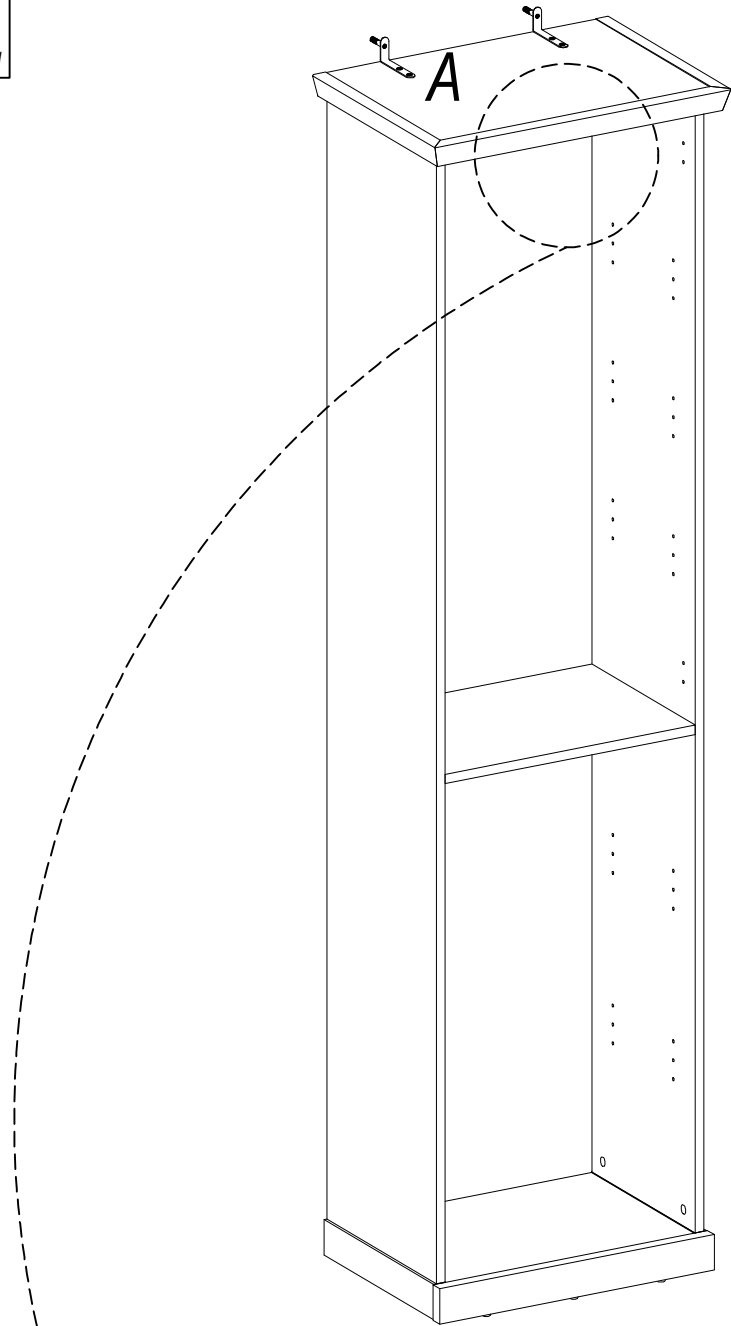
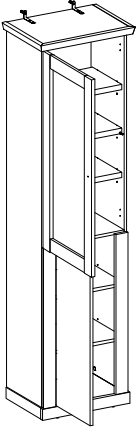

A

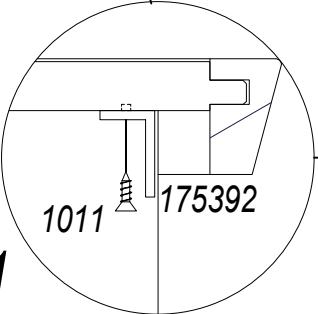

x1

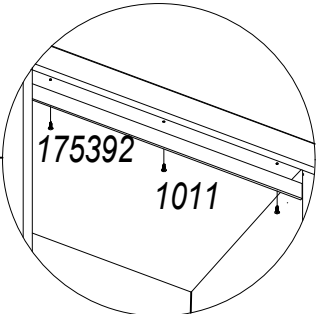

175392 1011

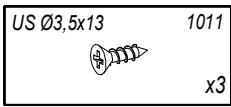
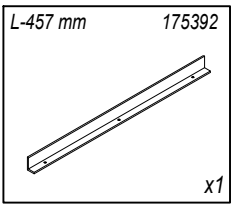

OPTION R

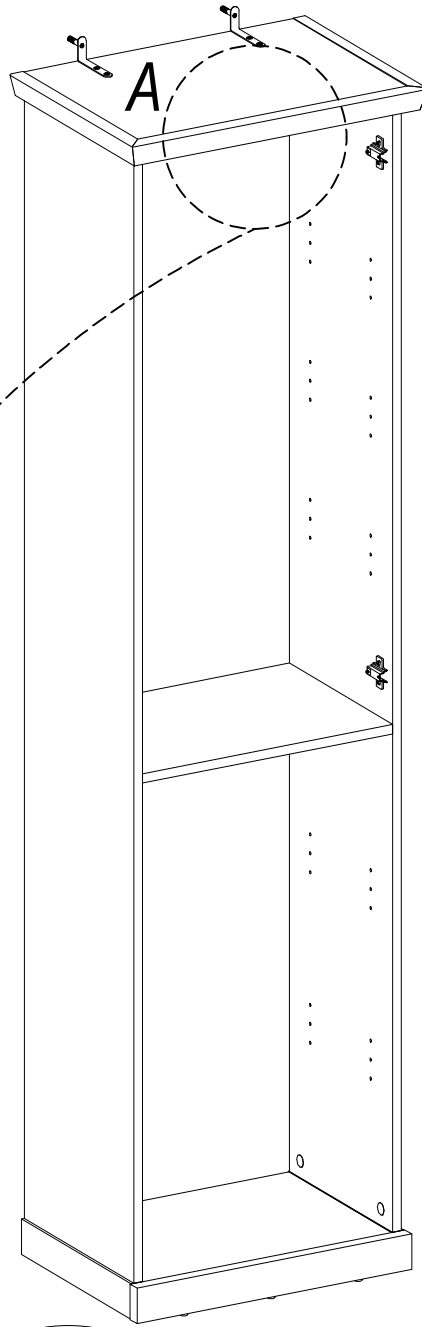
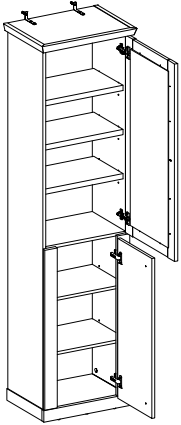

A

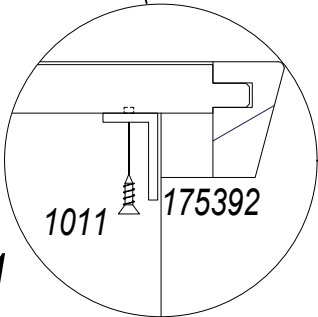

x1

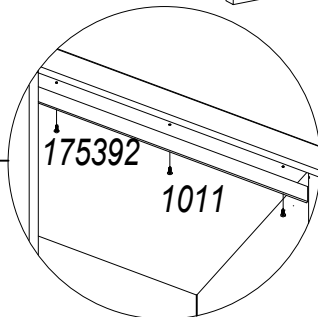

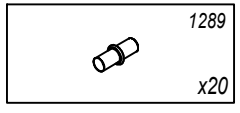

OPTION L

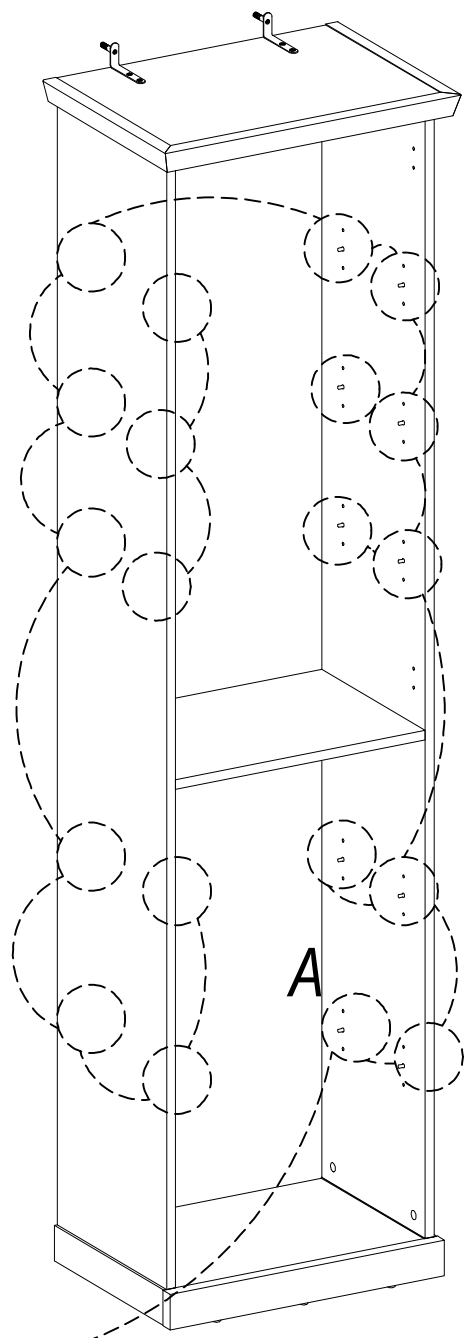
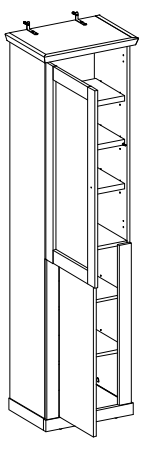

A

A

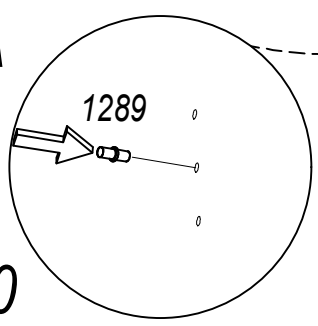

x20

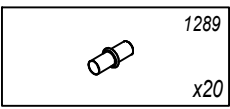

OPTION R

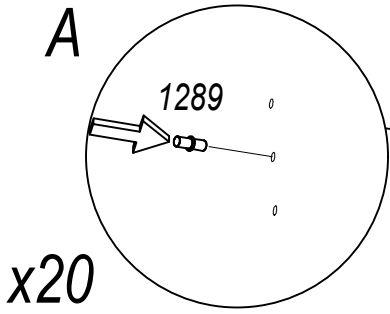
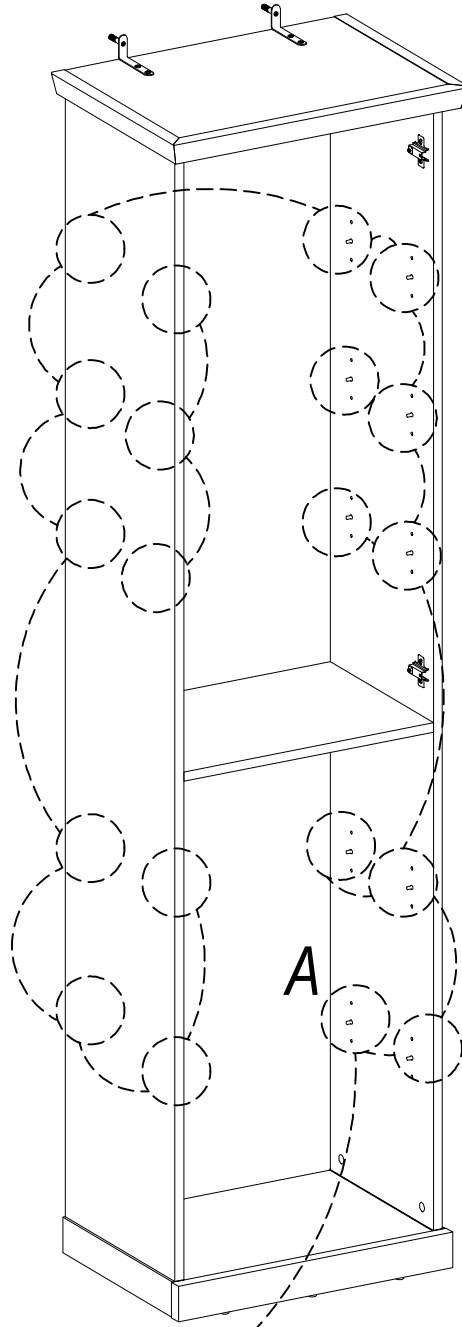
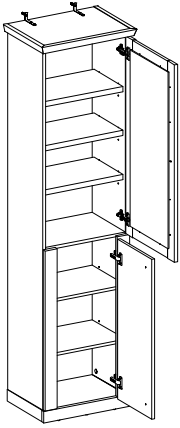

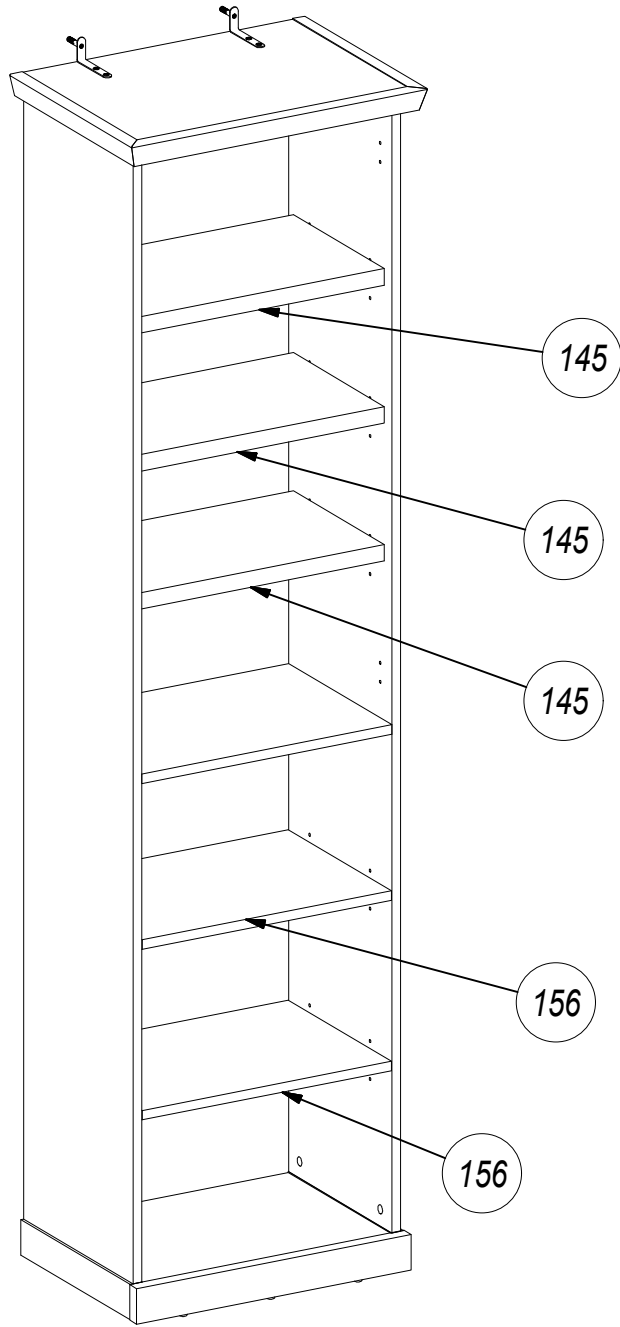
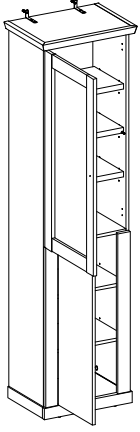

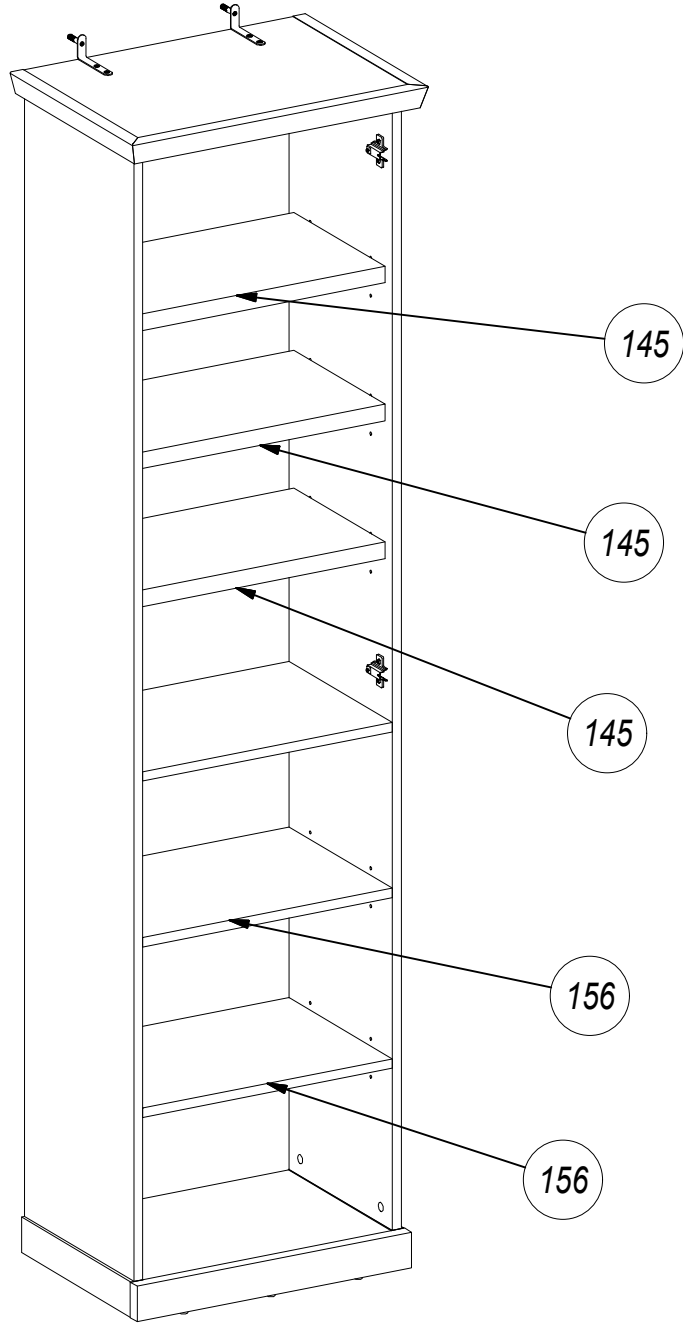
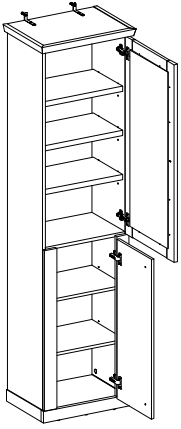

30x30x3 127317 x5

US Ø3,5x13 1011 x10

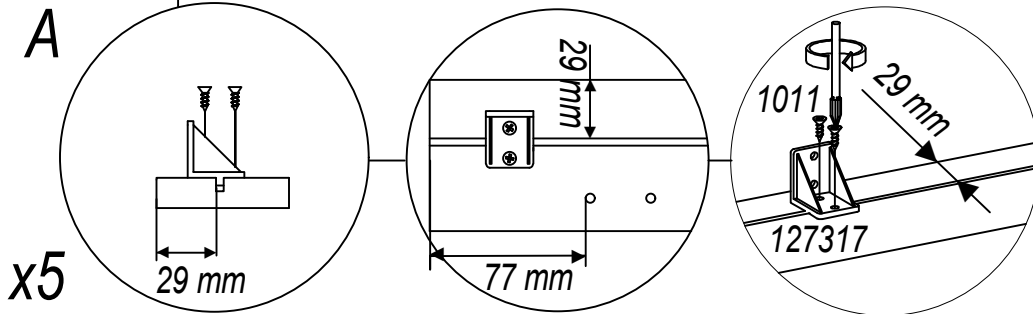
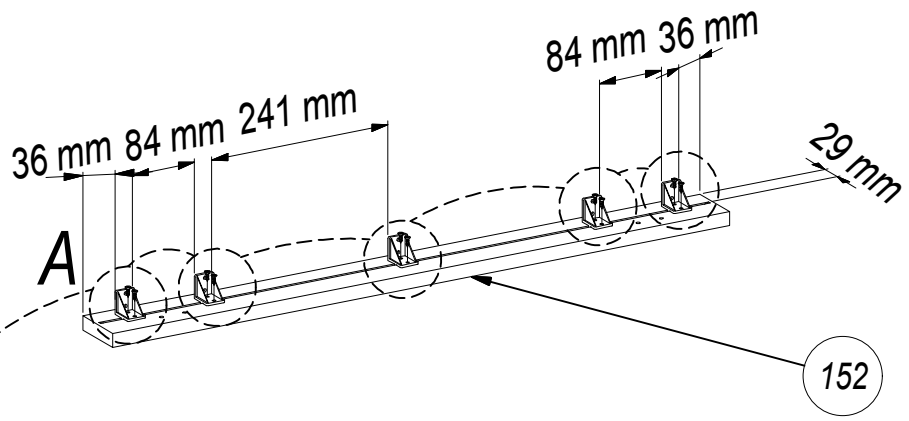

H-4 mm 23515 x2

OPTION L

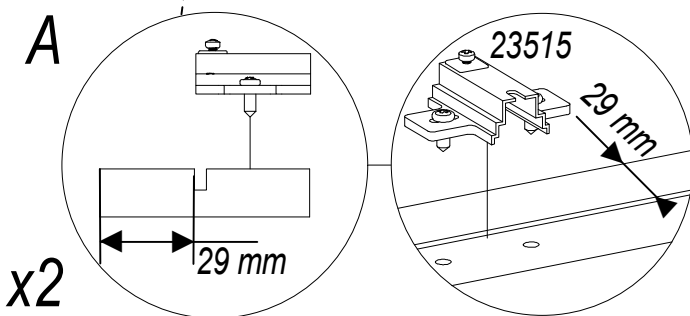
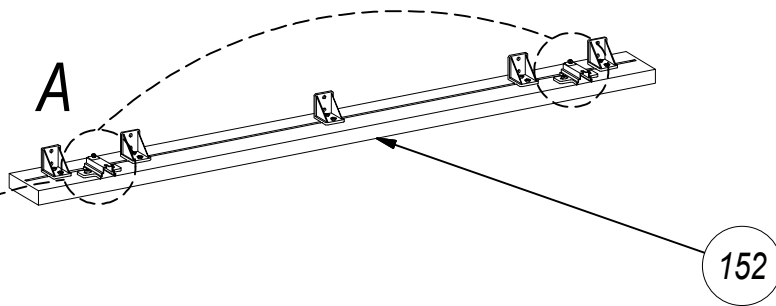
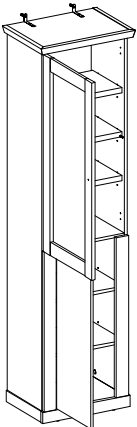

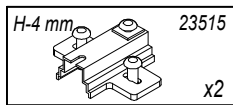
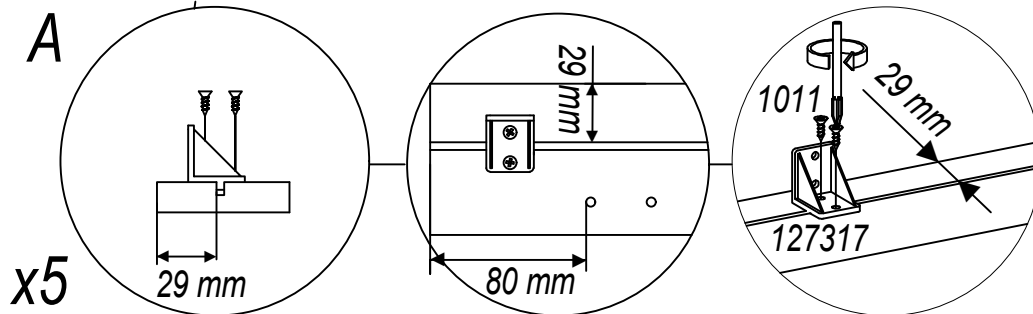
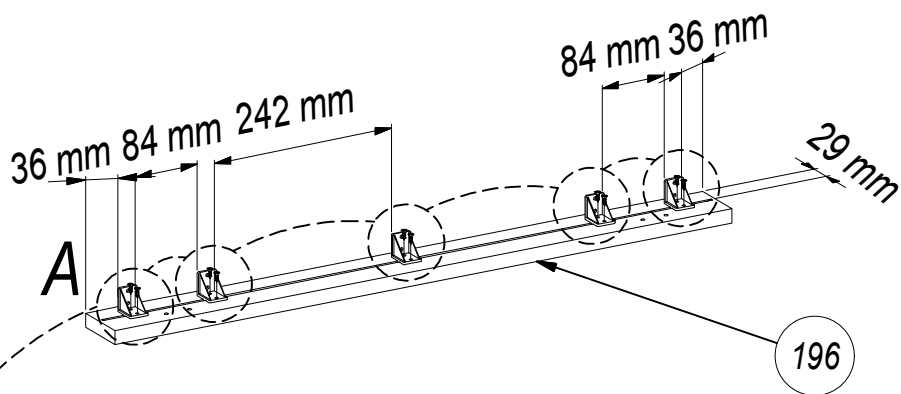
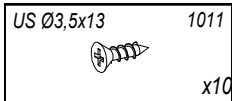
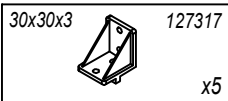

OPTION R

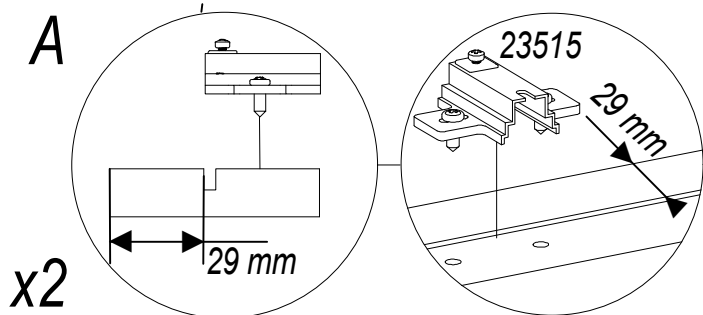
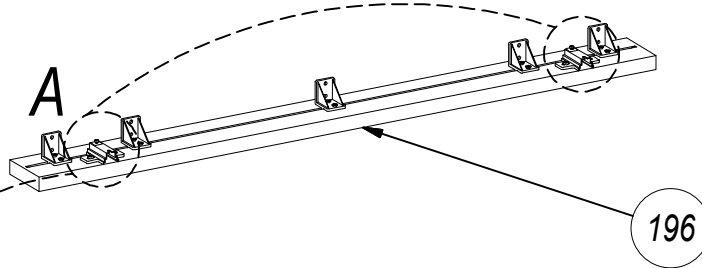
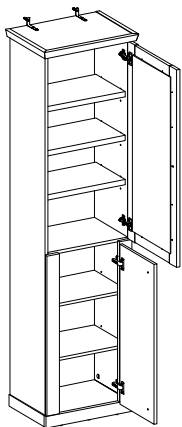

US Ø3,5x13 1011  
x20

OPTION L

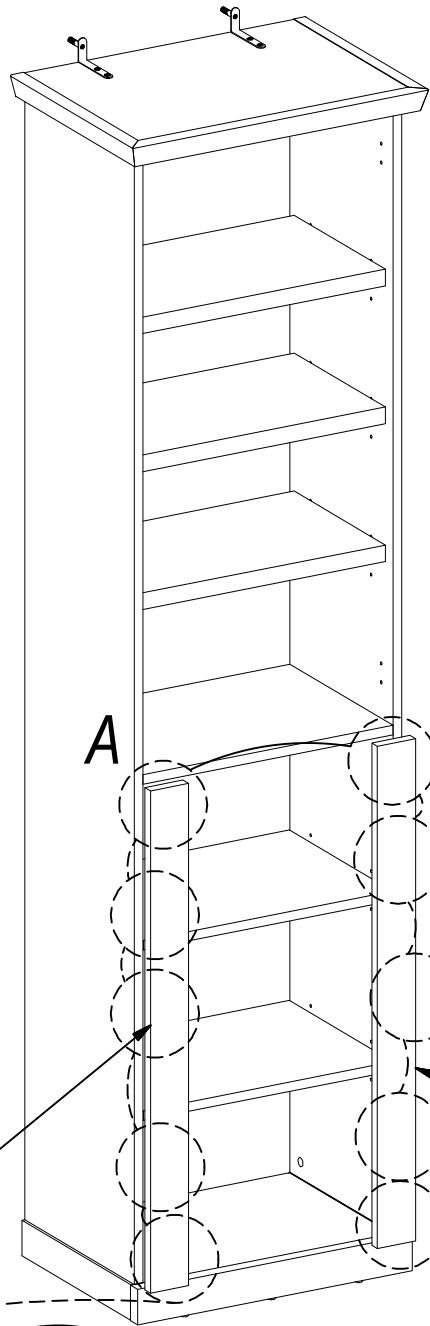
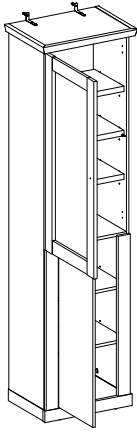

152

196

A

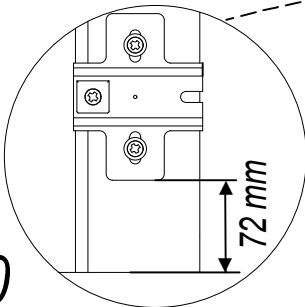

72 mm

x10

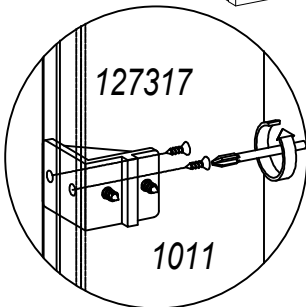



127317

1011

US Ø3,5x13 1011  
x20

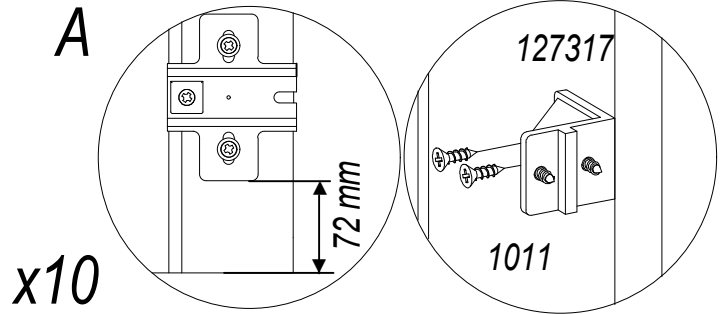
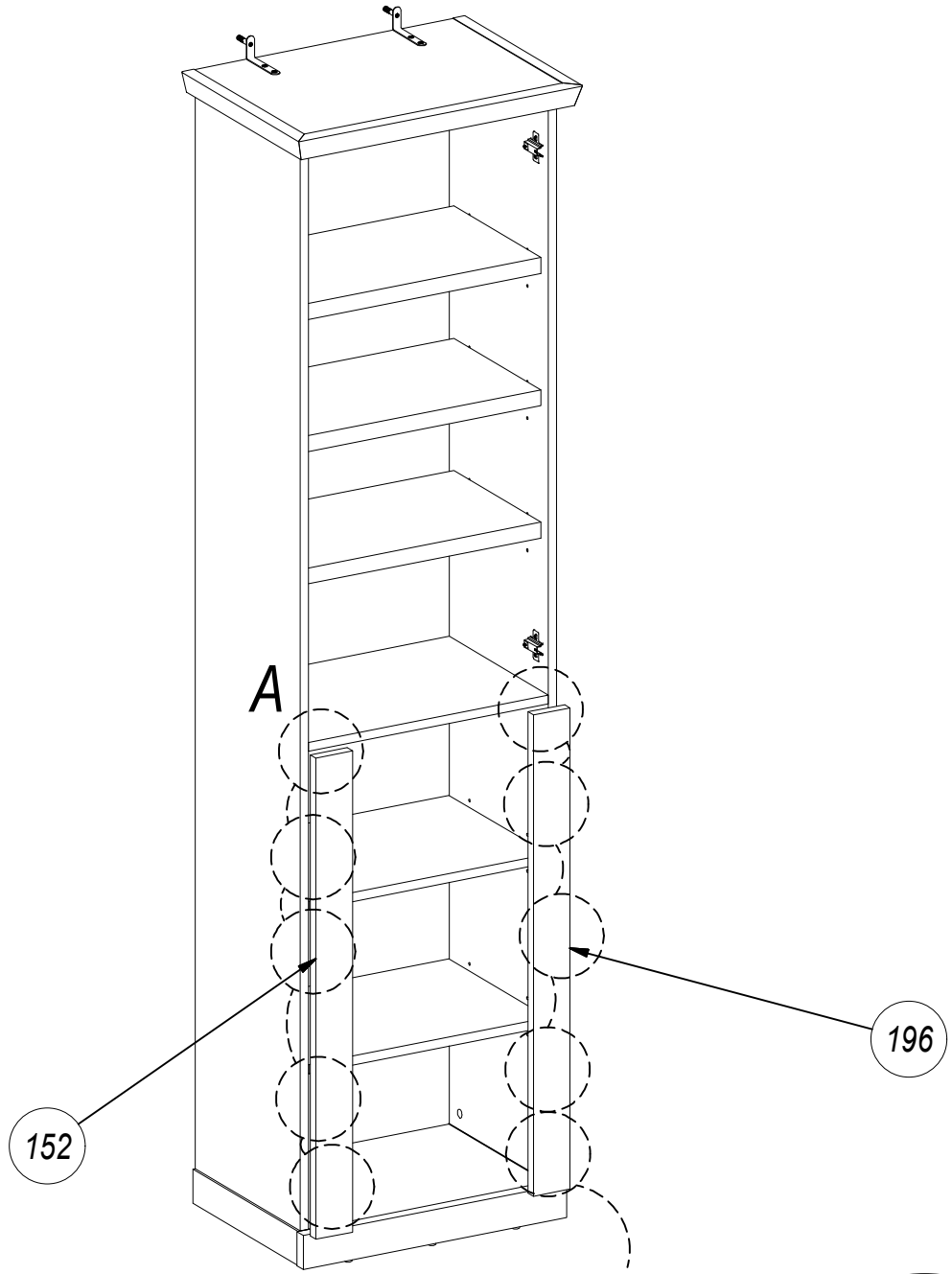
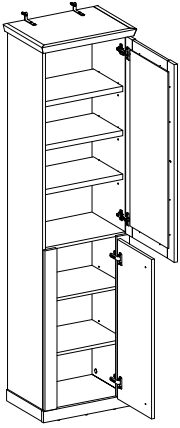
OPTION R



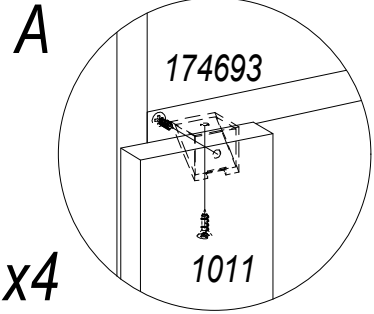
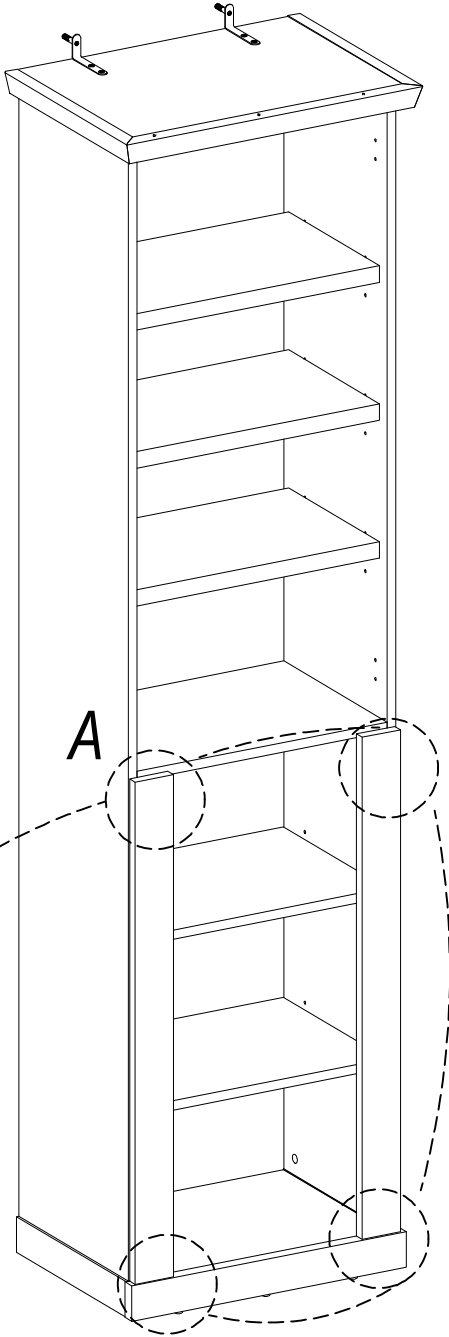
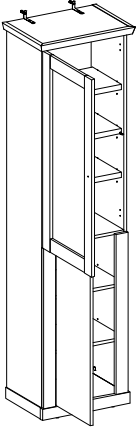

	174693	US Ø3,5x13	1011
x4			x8

OPTION L



x4

 174693 x4	 US Ø3,5x13 1011 x8
--------------------------------------------------------------------------------------------------	---------------------------------------------------------------------------------------------------------------

OPTION R

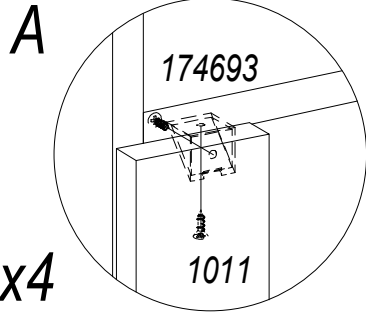
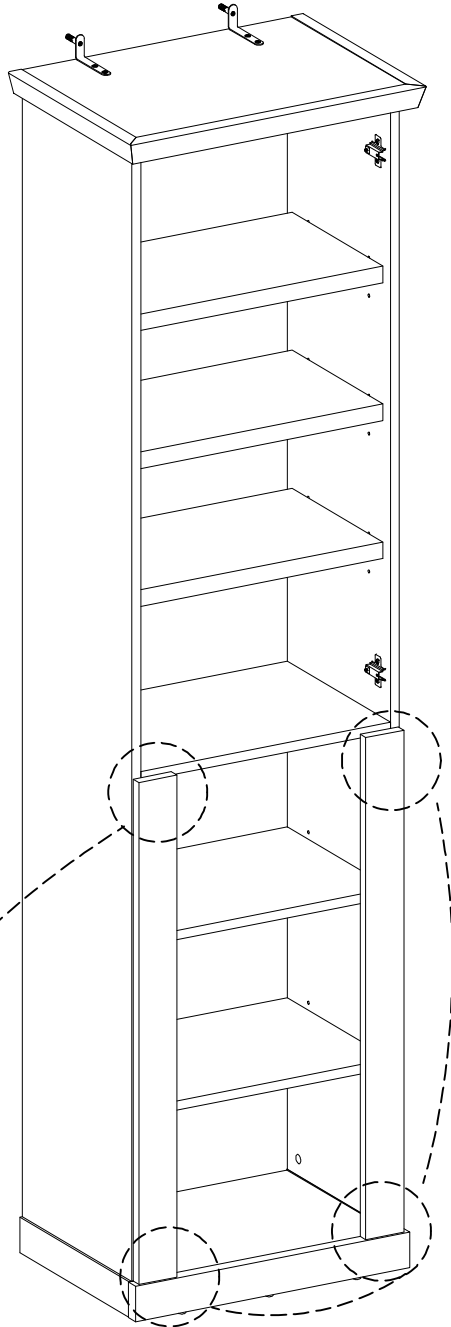
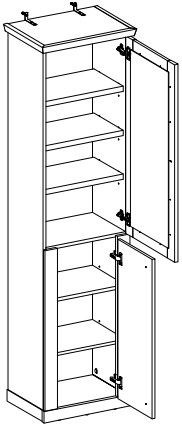

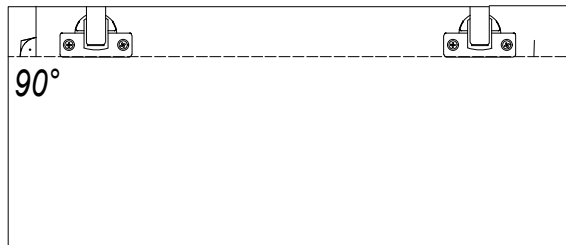
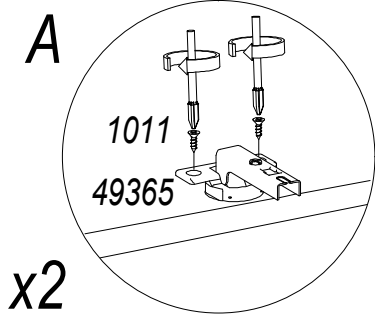
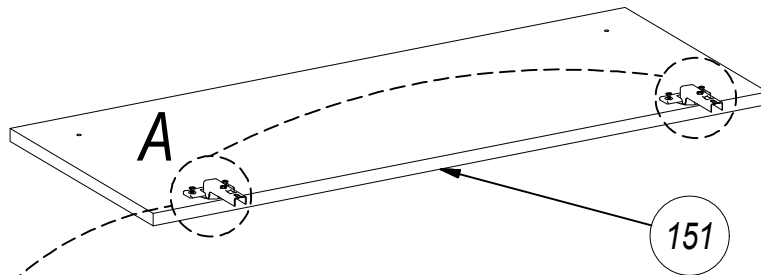
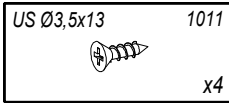
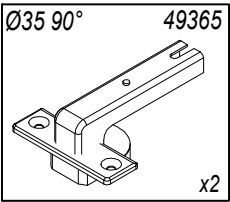

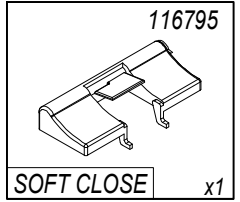

OPTION L

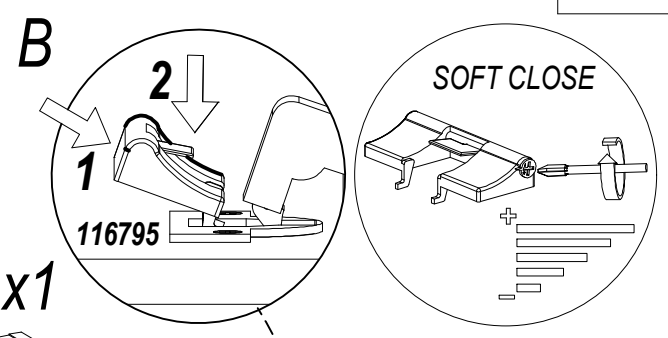
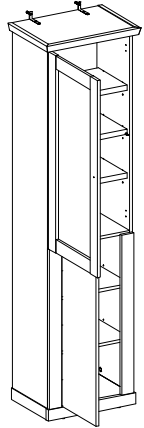

x1

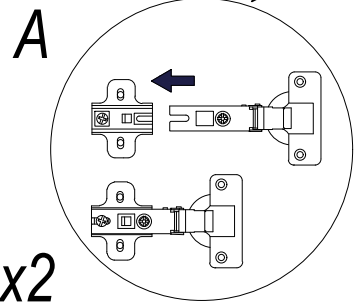
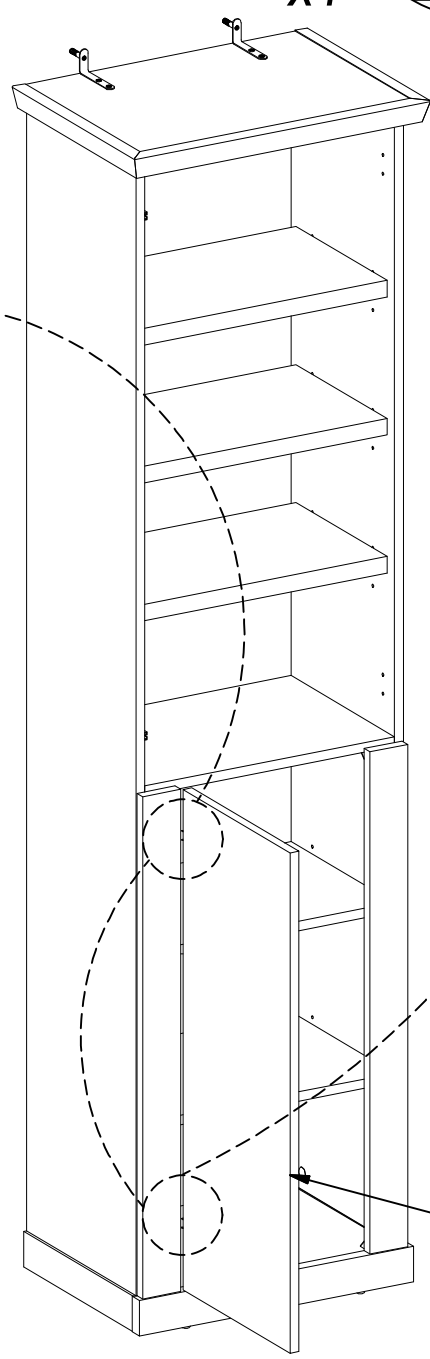

151

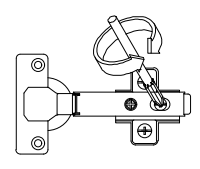
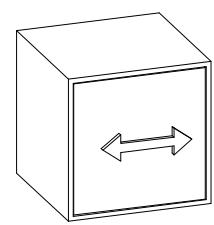
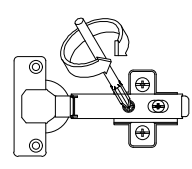
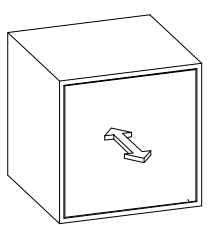
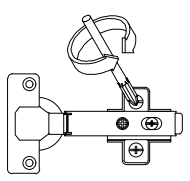
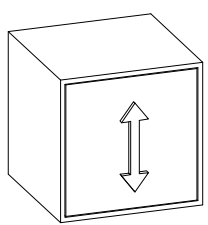

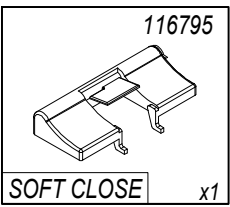

OPTION R

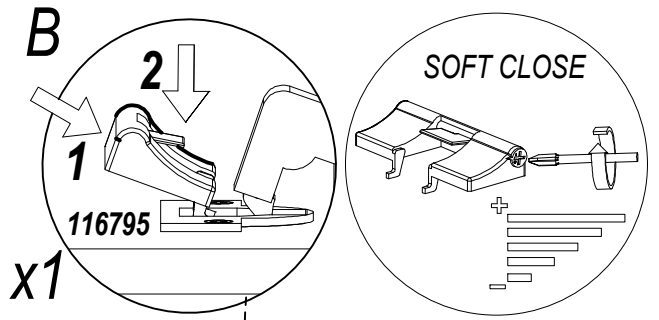
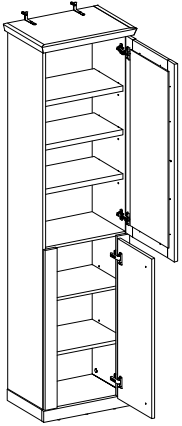

x1

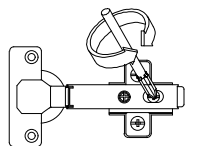
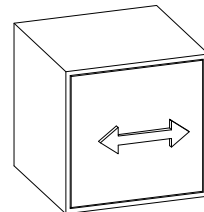
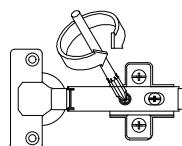
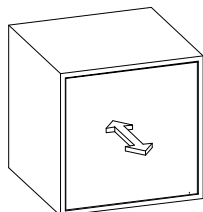
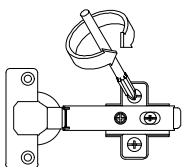
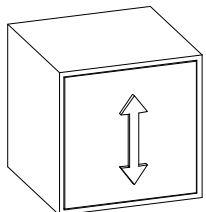
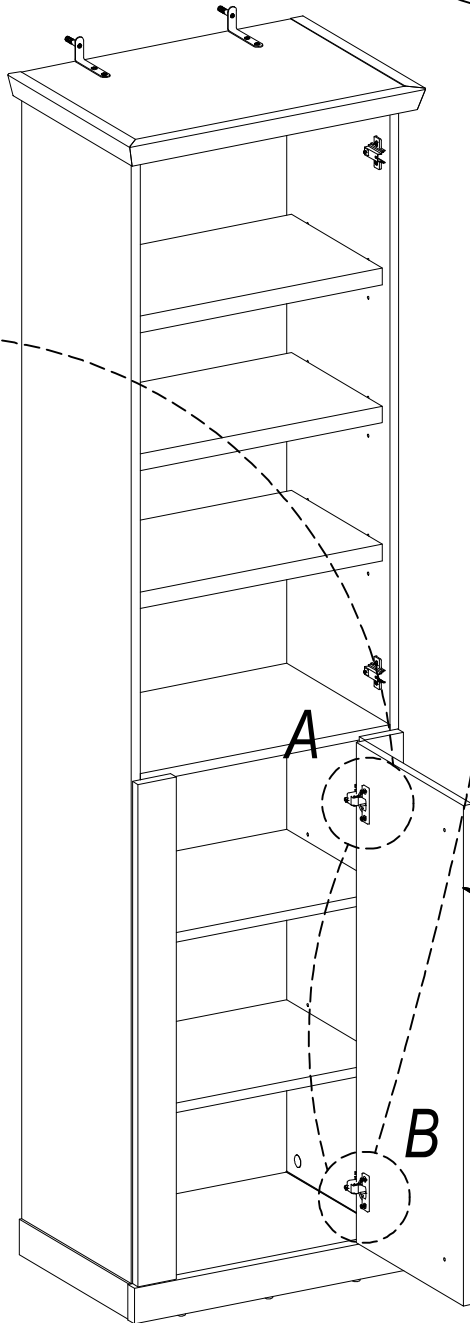
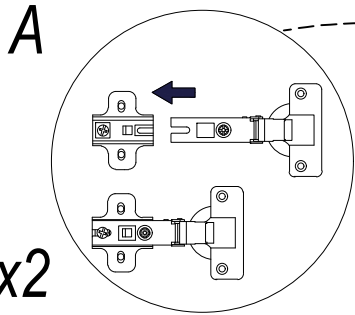

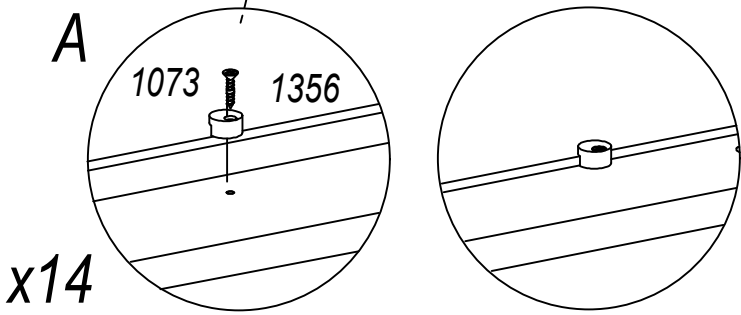
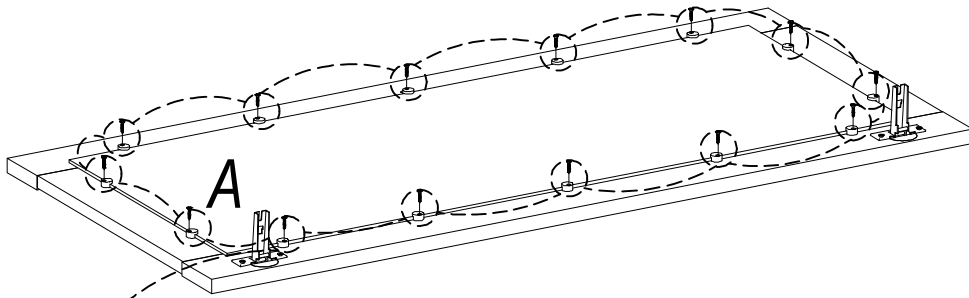
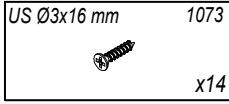
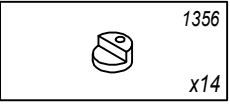
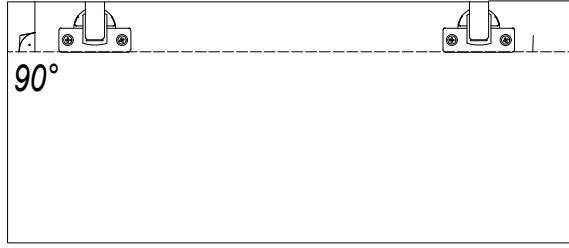
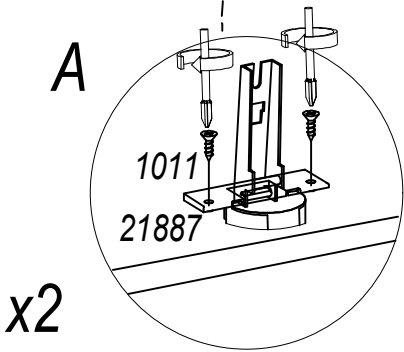
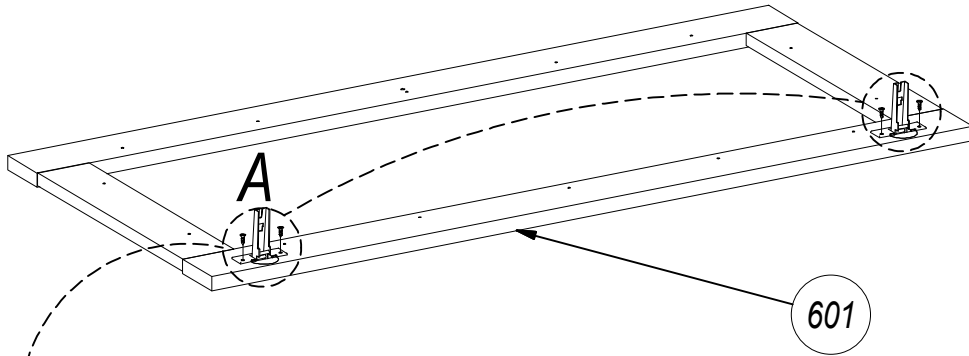
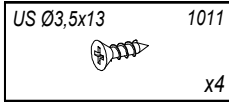
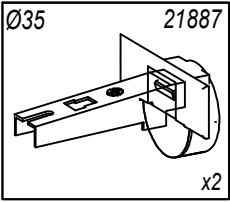

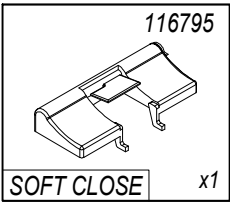

OPTION L

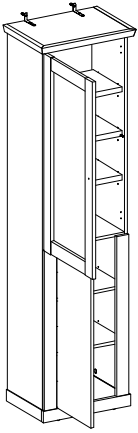

A

x2

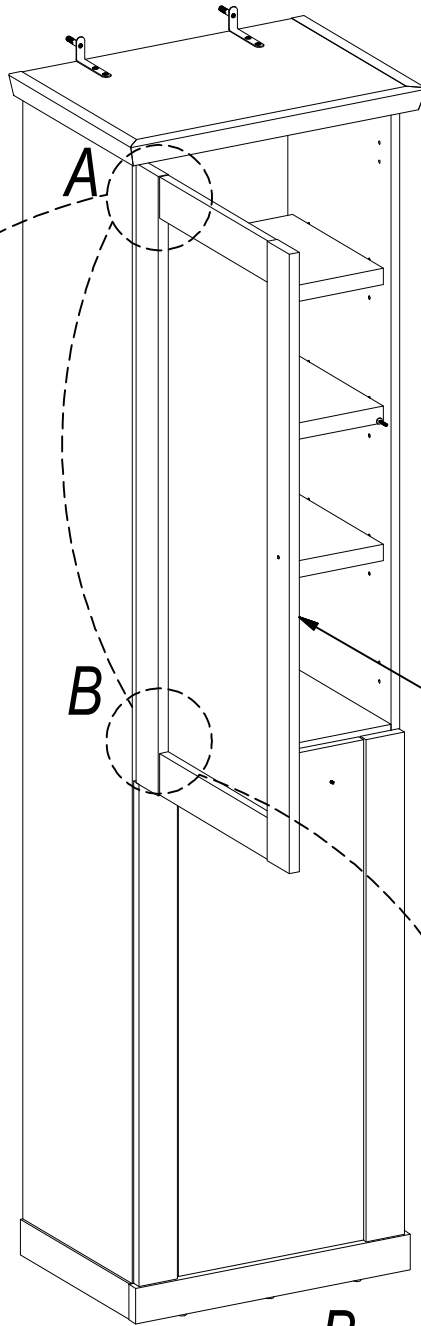
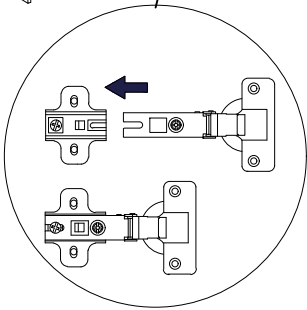

601

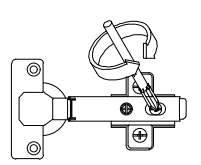
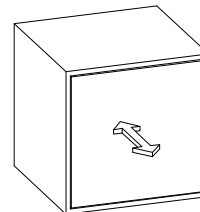
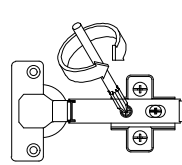
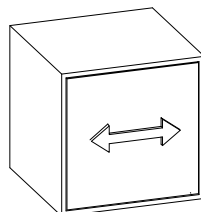
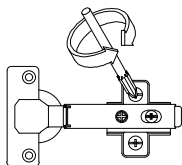
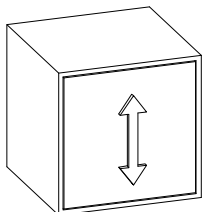
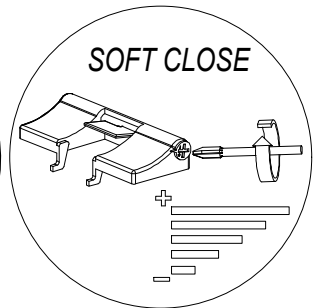
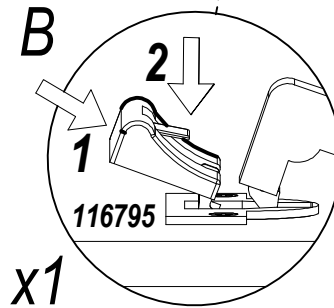

B

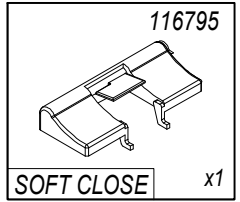



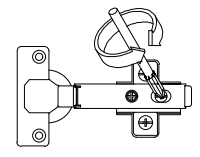
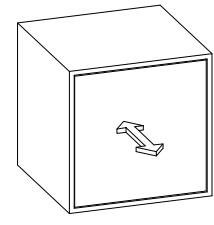
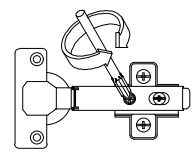
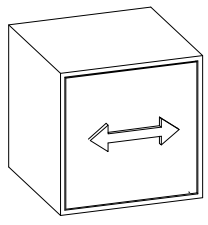
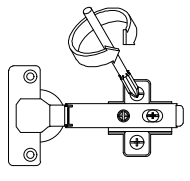
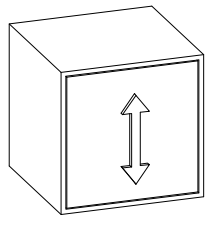
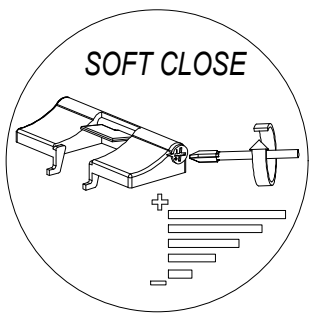
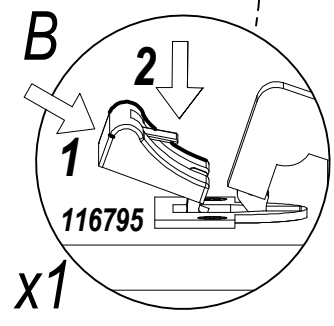
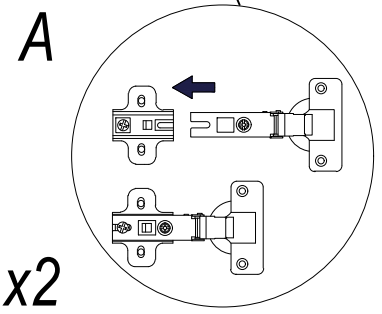
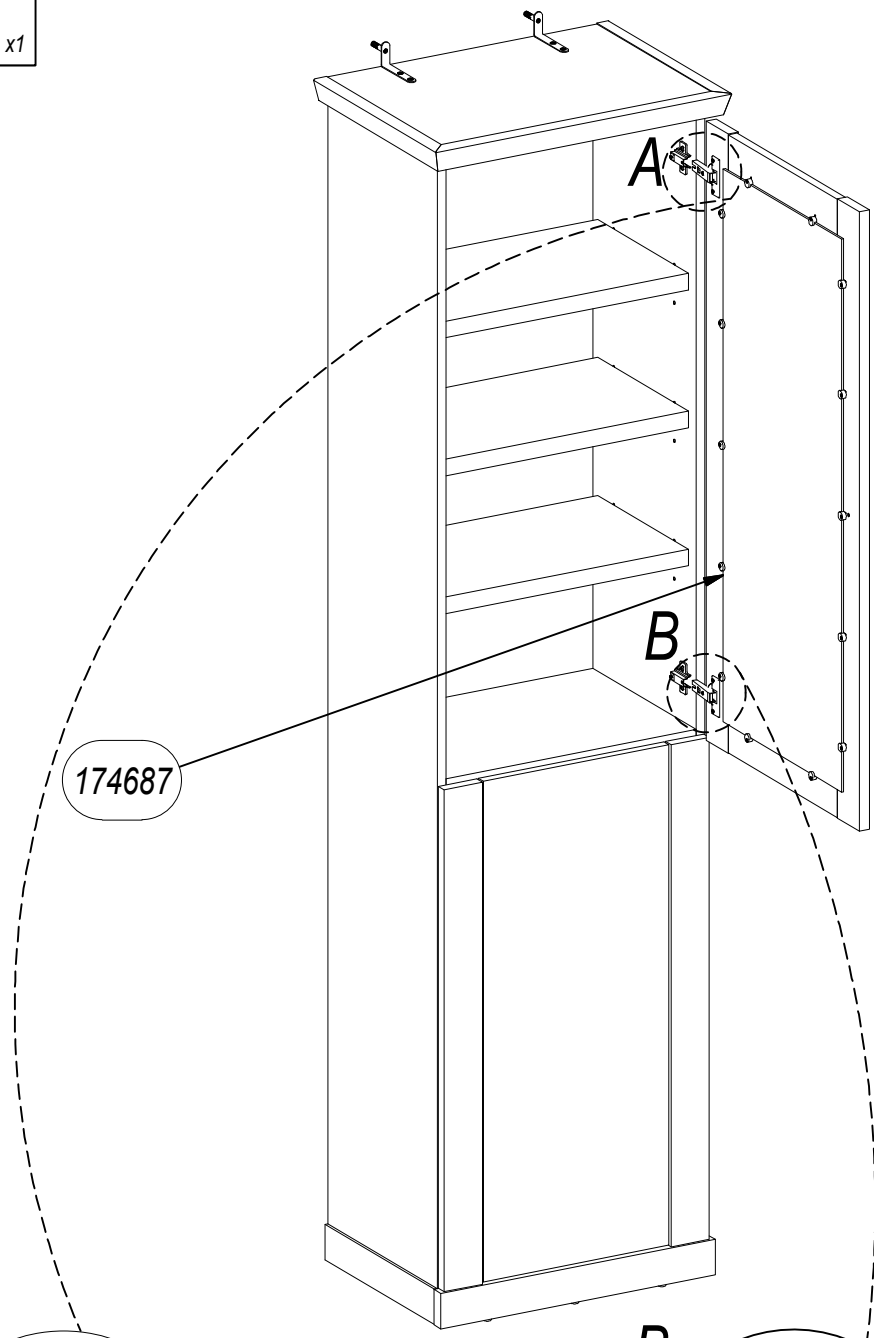
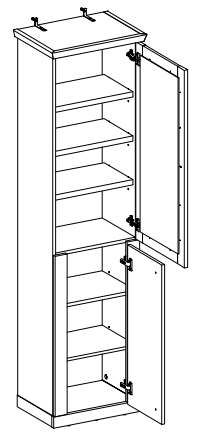

OPTION R

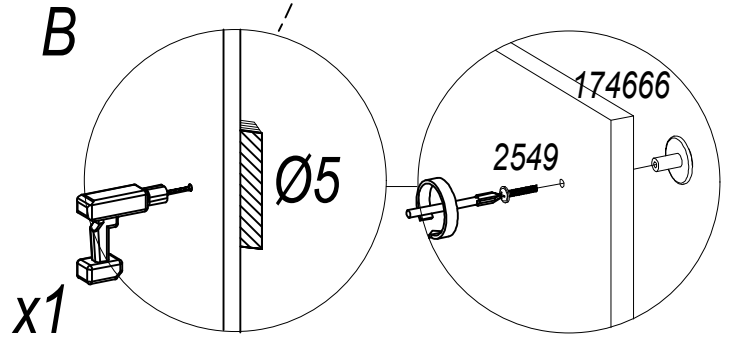
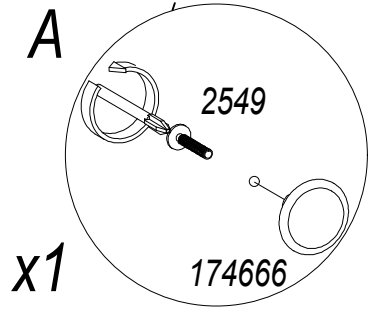
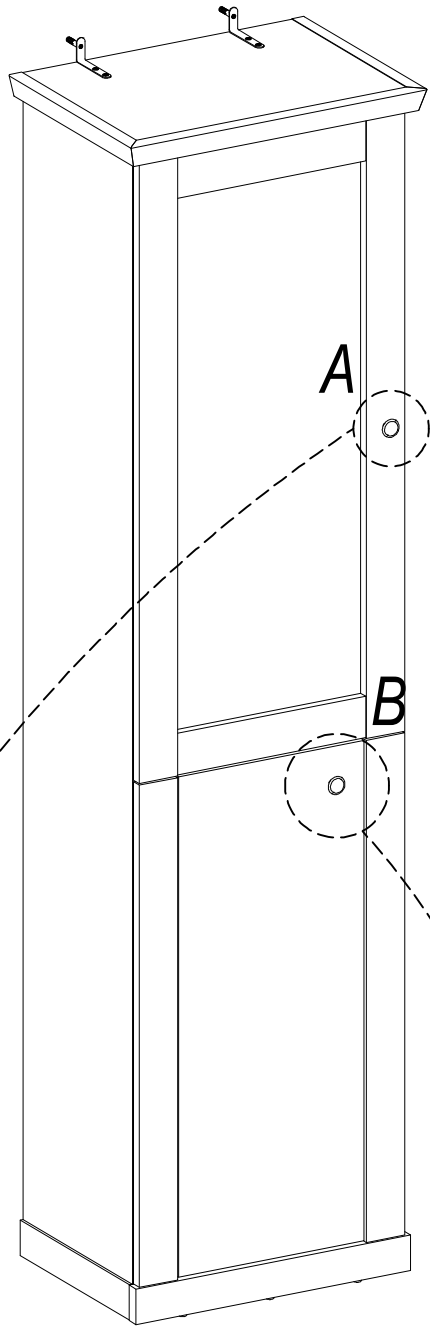
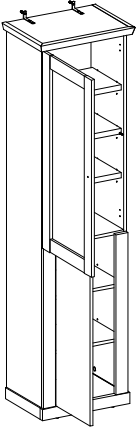

 174666 x2	 WPM Ø4x22 mm 2549 x2
--------------------------------------------------------------------------------------------------	----------------------------------------------------------------------------------------------------------------

OPTION L



	174666	WPM Ø4x22 mm	2549
x2			x2

OPTION R

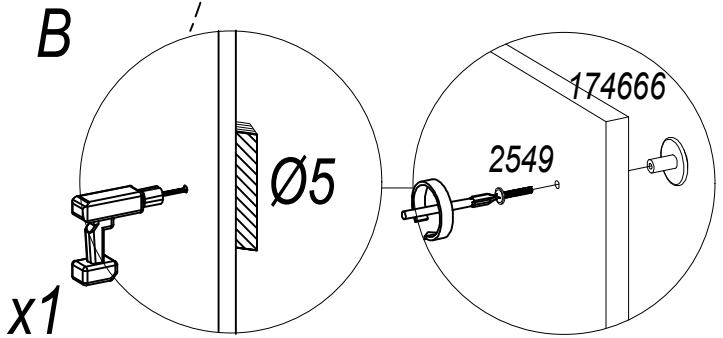
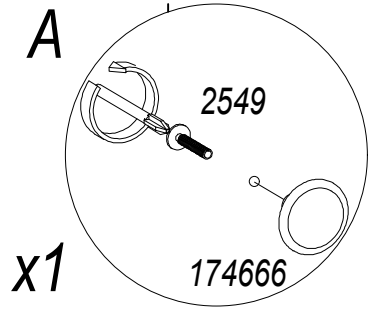
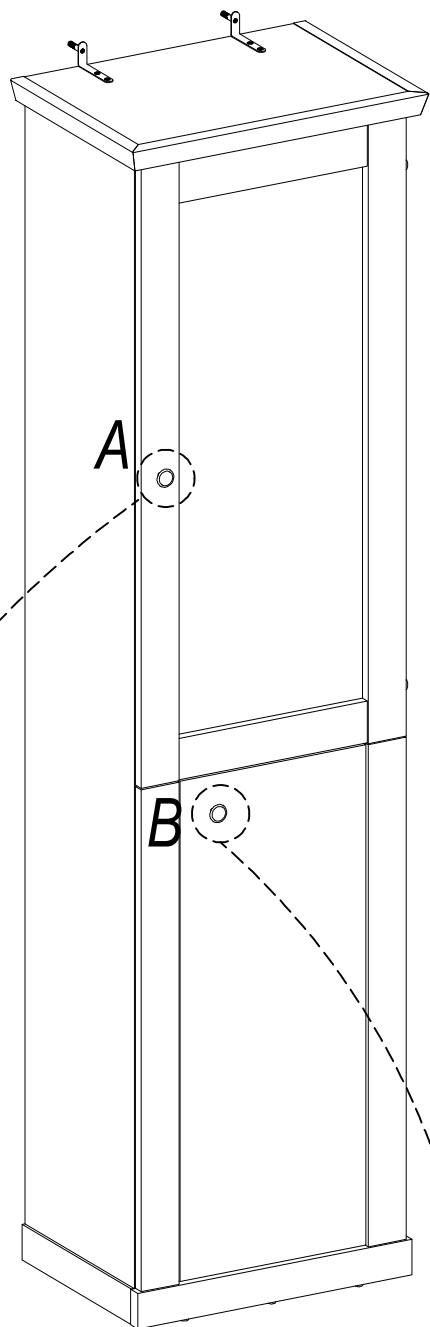
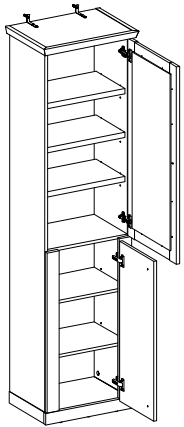

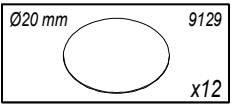

OPTION L

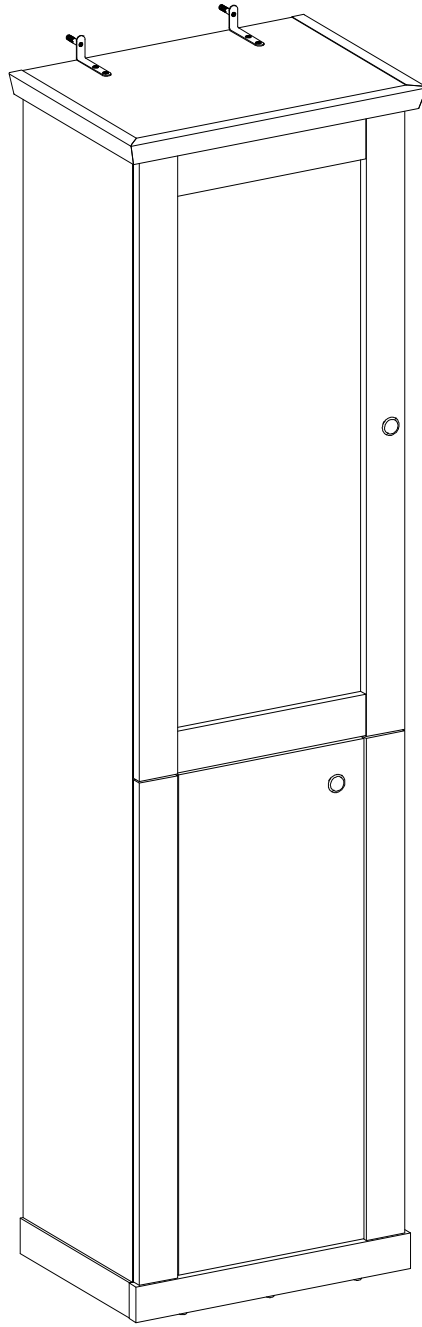
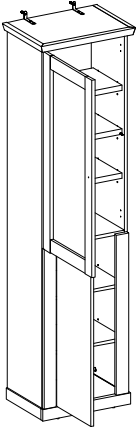

A

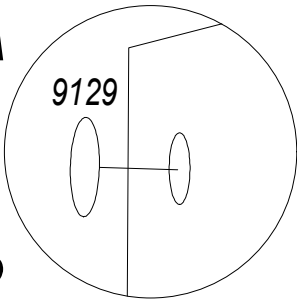

x12

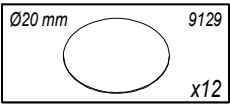

OPTION R

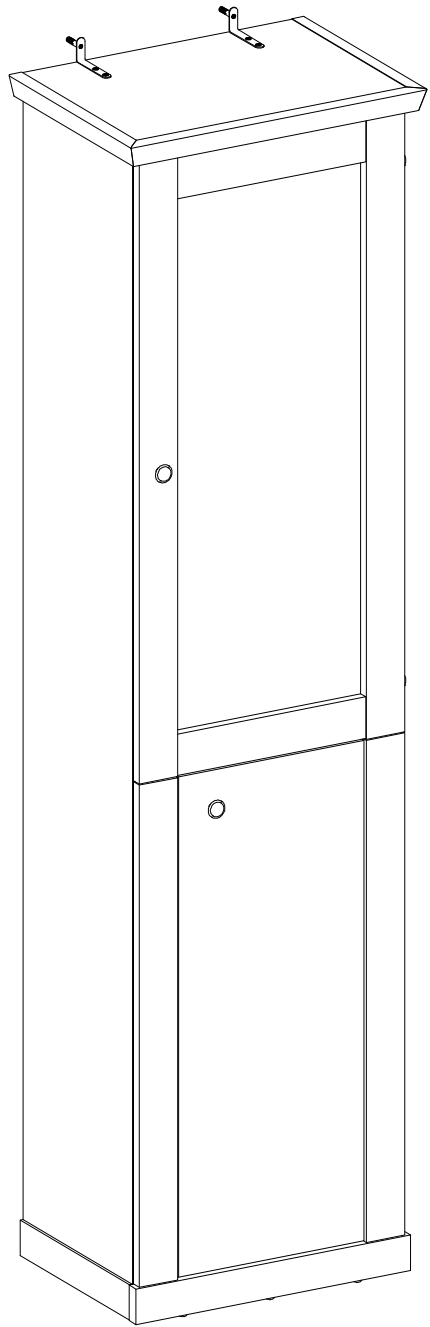
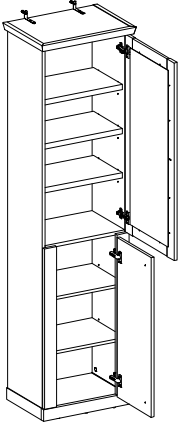

A

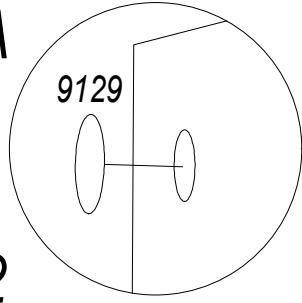

x12

# LINCOLN 5S MC LN 23

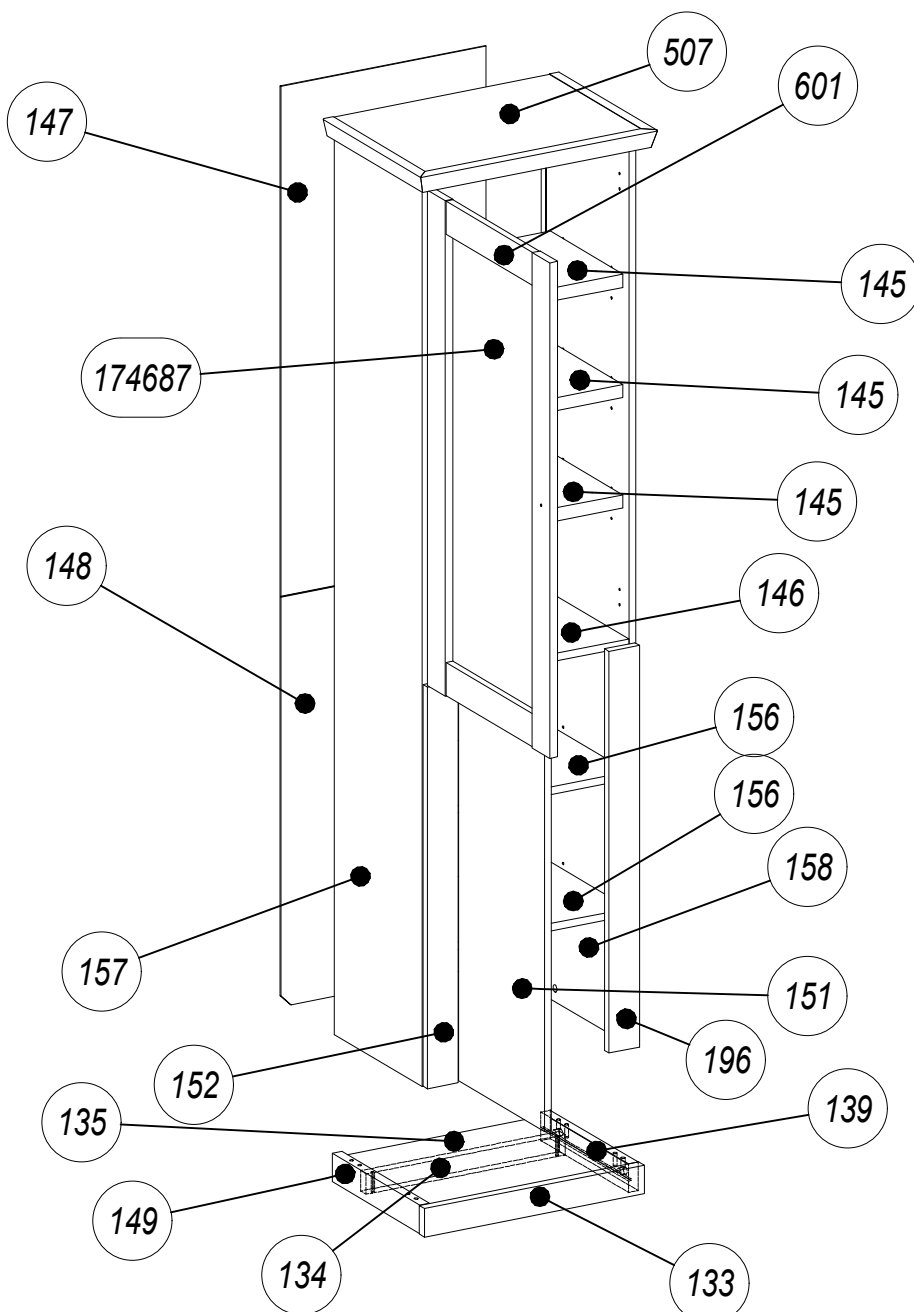

**D** Unser Direktservice für Beschlagteile  
Sollte Ihnen ein Beschlagteil fehlen, können Sie diese Servicekarte direkt an die untenstehende Adresse mailen. Wir können allerdings nur Beschlagteile auf diesem Wege verschicken. Sollten Sie eine andere Beanstandung an Ihrem Möbelstück haben, so wenden sie sich bitte direkt an Ihr Möbelhaus.

**GB** Our direct order service for fittings  
If a fitting part is missing, you can e-mail this service card directly to the address below. However, we can only send fitting parts in this way. If you have any other cause for complaint concerning your item of furniture, please contact your furniture store directly.

**CZ** Naše ořímé služby pro kování  
Chybí-li vám nějaký díl z kování, můžete tuto servisní kartu odeslat e-mailem přímo na níže uvedenou adresu. Touto cestou však můžeme zoslat jen díly kování. Pokud byste reklamovali jiný díl nábytku, obraťte se přímo na svého prodejce nábytku.

**F** Bien étudier la notice de montage  
Si il vous manque une ferrure, veuillez envoyer directement la présente carte service à l'adresse e-mail indiquée ci-dessous. Cependant, ceci nous permet uniquement d'envoyer des ferrures. Pour tout autre type de réclamation concernant votre meuble, veuillez contacter directement votre magasin d'ameublement.

**I** Il nostro servizio diretto per l'ordine della ferramenta  
Qualora Vi dovesse mancare un pezzo di fissaggio, allora Vi preghiamo di inviare questa carta di servizio immediatamente all'indirizzo sottostante. Possiamo inviare i pezzi di fissaggio solamente per mezzo di questo procedimento. Qualora dovreste avere qualche altra reclamazione in merito al mobile, allora Vi preghiamo di rivolgerVi direttamente al Vostro Negozio di mobili.

**BG** Нашата директна услуга за обкоя  
Ако липсват части от комплекта, попълнете настоящата сервисна карта и ни я изпратете на e-mail адреса, посочен по-долу. По този начин можем да доставяме само липсващи елементи от обкоя. Ако установите други дефекти по мебелите, Ви съветваме да се обърнете към мебелната къща/магазин, от който сте закупили стоката.

**NL** Onze directservice voor losse onderdelen  
Wanneer er een onderdeel ontbreekt, kunt u deze servicekaart direct aan onderstaand e-mailadres sturen. Wij kunnen langs deze weg echter alleen beslagdelen versturen. Mocht u een ander probleem aan uw meubel hebben, verzoeken wij u contact op te nemen met uw meubeldealer.

**PL** Nasz bezpośredni serwis części montażowych  
Jeżeli brakuje części koniecznych do montażu, prosimy o przesłanie nam niniejszej karty serwisowej na niżej podany adres e-mailowy. W ten sposób możemy przesłać Państwu tylko brakujące części. W przypadku innych reklamacji dotyczących mebla, prosimy zgłosić się do salonu meblowego, w którym został dokonany zakup.

**HR** Servis za okovje  
U slučaju da nedostaje neki od dijelova molimo vas da na dolje navedenu mail adresu pošaljete ovaj servisni obrazac. Na ovaj način mogu se dostaviti samo okovje. U slučaju da imate dodatne prigovore vezane uz komad namještaja molimo vas da se obratite izravno trgovini namještaja gdje je isti kupljen.

**HU** Direktszolgáltatunk vasalatók esetén  
Ha hiányzik egy vasalató, ezt a kártyát közvetlenül elküldheti az alább található címre. Azonban csak vasalatókat tudunk így küldeni. Amennyiben másfajta reklamáció áll fenn bütöndarabját illetően, forduljon közvetlenül a bütörháználhoz.

**SK** Náš priamy servis pre časti kovania  
Ak by vám chýbala nejaká časť kovania, môžete poslať túto servisnú kartu poslať e-mailom na nižšie uvedenú adresu. Díly kovania vieme poslať iba týmto spôsobom. Ak by ste mali inú reklamáciu ohľadom Vašho nábytku, obraťte sa priamo na Vašu predajňu nábytku.

**SLO** Naše direktne uslužne storitve za okovje  
Če vam manjka kakšno okovje, lahko to servisno kartico pošljete po e-pošti direktno na spodnji naslov. Po tej poti vam lahko pošljemo samo okovje. Če želite reklamirati kakšen drug del pohištva, se obrnite neposredno na vašo trgovino pohištva.

**RO** Service-ul nostru direct pentru feronerie  
In cazul în care vă lipsește o piesă de feronerie puteți să trimiteți direct acest card de service prin e-mail la adresa de mai jos. Noi nu putem expedia piese de feronerie decât pe această cale. Dacă aveți o altă reclamație referitoare la piesa de mobilier, atunci vă rugăm să vă adresați direct la magazinul dvs. de mobilă.

**RUS** Наш прямой сервис для поставок фурнитуры  
Если окажется, что Вам не хватает того или иного элемента фурнитуры, Вы можете отправить сервисную карту по факсу непосредственно на нижеприведенный адрес электронной почты. Однако, таким образом мы можем пересылать лишь фурнитуру. Если же у Вас возникнут иные претензии относительно приобретенной мебели, пожалуйста, обращайтесь непосредственно в организацию, осуществившую продажу.

**S** Vår direktservice för beslagsdelar  
Om du saknar en beslagsdel kan du skicka detta servicekort direkt till e-postadressen som anges nedan. Tank på att detta är den enda möjligheten att skicka beslagsdelar till dig. Om du vill reklamera din möbel av en annan anledning måste du kontakta ditt möbelhus direkt.

**ES** Nuestro servicio directo para accesorios  
Si le falta algún accesorio, puede enviar esta tarjeta de servicio directamente a la siguiente dirección. No obstante, por este método solo podemos enviar accesorios. Si tiene alguna otra objeción sobre su mueble, consulte directamente con su mueblería.

**TR** Donatılar için doğrudan servisimiz  
Bir donatınız eksikse bu servis kartını doğrudan aşağıda bulunan adrese doğrudan mail yazabilirsiniz. Sadece bu yolla donatılar gönderiliriz. Mobilyanızda başka şikayetleriniz varsa lütfen doğrudan mobilya satıcınıza danışın.

AI No.	QTY	H	W	D	PKG
133	1	503	60	22	1/2
134	1	456	43	22	1/2
135	1	456	327	16	1/2
139	1	347	60	22	1/2
145	3	457	288	28	1/2
146	1	458	327	16	1/2
147	1	1076	470	2,5	2/2
148	1	865	470	2,5	2/2
149	1	347	60	22	1/2
151	1	845	340	16	2/2
152	1	848	70	18	2/2
156	2	457	327	16	1/2
157	1	1921	347	16	2/2
158	1	1921	347	16	2/2
174687	1	934	376	4	2/2
196	1	848	70	18	2/2
507	1	542	388	38	1/2
601	1	486	1046	18	2/2

# LINCOLN 5S MC LN 23

**D** Unser Direktservice für Beschlagteile  
Sollte Ihnen ein Beschlagteil fehlen, können Sie diese Servicekarte direkt an die untenstehende Adresse schicken. Wir können allerdings nur Beschlagteile auf diesem Wege verschicken. Sollten Sie eine andere Beanstandung an Ihrem Möbelstück haben, so wenden sie sich bitte direkt an Ihr Möbelhaus.

**GB** Our direct order service for fitting  
If a fitting part is missing, you can e-mail this service card directly to the address below. However, we can only send fitting parts in this way. If you have any other cause for complaint concerning your item of furniture, please contact your furniture store directly.

**CZ** Naše přímé služby pro kování  
Chybí-li vám nějaký díl z kování, můžete tuto servisní kartu odeslat e-mailem přímo na níže uvedenou adresu. Touto cestou však můžeme zoslat jen díly kování. Pokud byste reklamovali jiný díl nábytku, obraťte se přímo na svého prodejce nábytku.

**F** Bien étudier la notice de montage  
S'il vous manque une ferrure, veuillez envoyer directement la présente carte service à l'adresse e-mail indiquée ci-dessous. Cependant, ceci nous permet uniquement d'envoyer des ferrures. Pour tout autre type de réclamation concernant votre meuble, veuillez contacter directement votre magasin d'aménagement.

**I** Il nostro servizio diretto per l'ordine della ferramenta  
Qualora Vi dovesse mancare un pezzo di fissaggio, allora Vi preghiamo di inviare questa carta di servizio immediatamente all'indirizzo sottostante. Possiamo inviare i pezzi di fissaggio solamente per mezzo di questo procedimento. Qualora dovreste avere qualche altra reclamazione in merito al mobile, allora Vi preghiamo di rivolgerVi direttamente al Vostro Negozio di mobili.

**BG** Нашата директна услуга за обков  
Ако липсват части от комплекта, попълнете настоящата сервисна карта и ни я изпратете на e-mail адреса, посочен по-долу. По този начин можем да доставяме само липсващи елементи от обкова. Ако установите други дефекти по мебелите, Ви съветваме да се обърнете към мебелната къща/магазин, от който сте закупили стоката.

**NL** Onze directservice voor losse onderdelen  
Wanneer er een onderdeel ontbreekt, kunt u deze servicekaart direct aan onderstaand e-mailadres sturen. Wij kunnen langs deze weg echter alleen beslagdelen versturen. Mocht u een ander probleem aan uw meubel hebben, verzoeken wij u contact op te nemen met uw meubeldealer.

**PL** Nasz bezpośredni serwis części montażowych  
Jeżeli brakuje części koniecznych do montażu, prosimy o przesłanie nam niniejszej karty serwisowej na niżej podany adres e-mailowy. W ten sposób możemy przesyłać Państwu tylko brakujące części. W przypadku innych reklamacji dotyczących mebla, prosimy zgłosić się do salonu meblowego, w którym został dokonany zakup.

**HR** Služba za okove  
U slučaju da nedostaje neki od dijelova molimo vas da na dolje navedenu mail adresu pošaljete ovaj servisni obrazac. Na ovaj način mogu se dostaviti samo okovi. U slučaju da imate dodatne prigovore vezane uz komad namještaja molimo vas da se obratite izravno trgovini namještaja gdje je isti kupljen.

**HU** Direktszolgáltatunk vasalatok esetén  
Ha hiányzik egy vasalat, azt a kártyát közvetlenül elküldheti az alább található címre. Azonban csak vasalásokat tudunk így küldeni. Amennyiben másfajta reklamáció áll fenn bútorárbáját illetően, forduljon közvetlenül a bútoráruházhoz.

**SK** Náš priamy servis pre časti kovania  
Ak by vám chýbala nejaká časť kovania, môžete poslať túto servisnú kartu poštou e-mailom na nižšie uvedenú adresu. Díly kovania vieme poslať iba týmto spôsobom. Ak by ste mali inú reklamáciu ohľadom Vašho nábytku, obraťte sa priamo na Vašu predajňu nábytku.

**SLO** Naše direktno uslužne storitve za okovje  
Ce vam manjka kakšno okovje, lahko to servisno kartico pošijete po e-pošti direktno na spodnji naslov. Po tej poti vam lahko pošljemo samo okovje. Če želite reklamirati kakšen drug del pohištva, se obrnite neposredno na vašo trgovino pohištva.











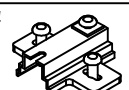



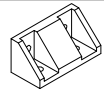



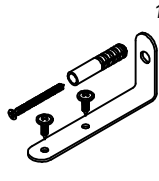
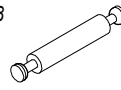
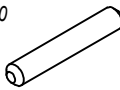

**RO** Service-ul nostru direct pentru feronerie  
In cazul in care va lipseste o piesa de feronerie puteti să trimiteți direct acest card de service prin e-mail la adresa de mai jos. Noi nu putem expedia piese de feronerie decât pe această cale. Dacă aveți o altă reclamație referitoare la piesa de mobilier, atunci vă rugăm să vă adresați direct la magazinul dvs. de mobilă.

**RUS** Наш прямой сервис для поставок фурнитуры  
Если окажется, что Вам не хватает того или иного элемента фурнитуры, Вы можете отправить сервисную карту по факсу непосредственно на нижеприведенный адрес электронной почты. Однако, таким образом мы можем пересылать лишь фурнитуру. Если же у Вас возникнут иные претензии относительно приобретенной мебели, пожалуйста, обращайтесь непосредственно в организацию, осуществившую продажу.

**S** Vår direktservice för beslagsdelar  
Om du saknar en beslagsdel kan du skicka detta servicekort direkt till e-postadressen som anges nedan. Tank på att detta är den enda möjligheten att skicka beslagsdelar till dig. Om du vill reklamera din möbel av en annan anledning måste du kontakta ditt möbelhus direkt.

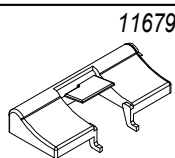
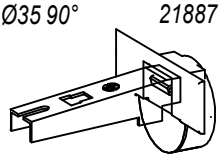
**ES** Nuestro servicio directo para accesorios  
Si le falta algún accesorio, puede enviar esta tarjeta de servicio directamente a la siguiente dirección. No obstante, por este método solo podemos enviar accesorios. Si tiene alguna otra objeción sobre su mueble, consulte directamente con su mueblería.

**TR** Donatılar için doğrudan servisimiz  
Bir donatılar eksikse bu servis kartını doğrudan aşağıda bulunan adrese doğrudan mail yazabilirsiniz. Sadece bu yolla donatıları gönderebiliriz. Mobilyanızda başka şikayetleriniz varsa lütfen doğrudan mobilya satıcınıza danışın.

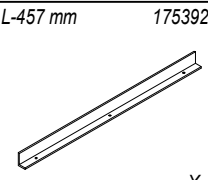
US Ø3,5x13  1011 X...	H-4  23515 X...	Ø8x28  1018 X...
L-38 mm  11809 X...	Ø15x12,5  123894 X...	 127314 X...
30x30x3  127317 X...	 1289 X...	 1305 X...
 1302 X...	UP Ø3x20 mm  1056 X...	23x10x2 mm  1415 X...
 1267 X...	L-48  18264 X...	Ø8x50  1272 X...
 1356 X...	Ø20 mm  9129 X...	 174693 X...
 Ø35 90° 21887 X...	US Ø3x16 mm  1073 X...	 116795 X...
 Ø35 90° 49365 X...	 SOFT CLOSE X...	 174666 X...
WPM Ø4x22 mm  2549 X...	L-457 mm  175392 X...	

