

06410015-03

1217501

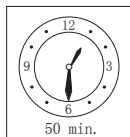

festziehen ytighen уЗатенер у
serrer ystringere utáhnout yvastrekken y
zategnuti ystrangere yzwiazac y
szorosan meghúzni urevne dotiahnut' y
trdno pritegniti uzatyanyt' ydra at y

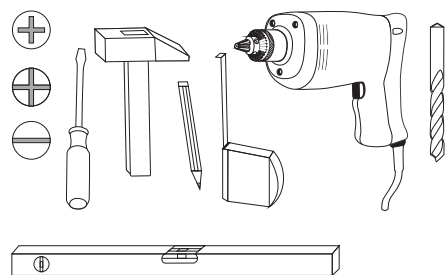
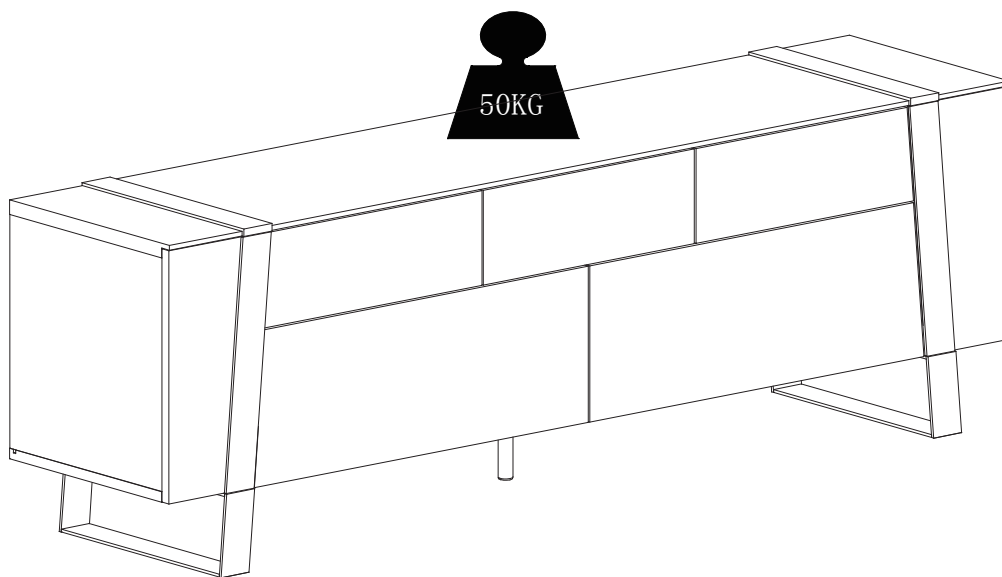

eindrücken ypress in yenfocer y
ribattere yzatlačit yВкарайте у
Benyomni ystlacit' yvtisniti utryck iny
introducere prin apasare удавить у



ausmessen ymeasure ymesures y
misurare yopmeten yizmeriti ymiara y
kiméni yizmeriti ymasurare uyizmerit' y
změřit' yИзмерете умат upp y



drücken ypress ypresser ystisknout y
HaTNCHeTe yvtisniti ynasinac ydrukken y
pritisnuti ynacisnac upritisniti унажать у
ИМегЗуомни уapasare utryck fast y









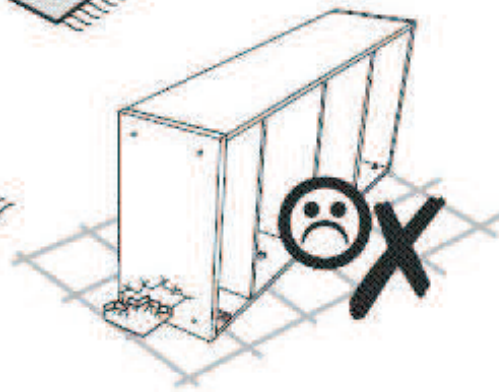
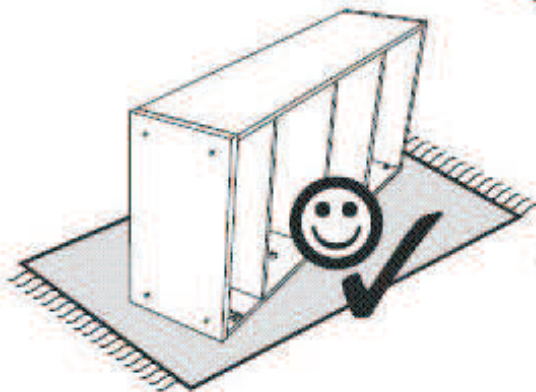
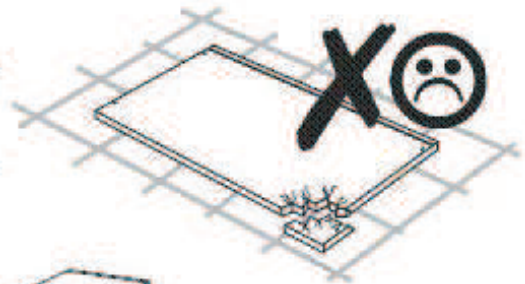
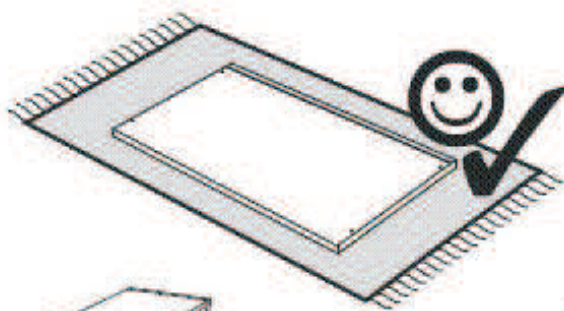
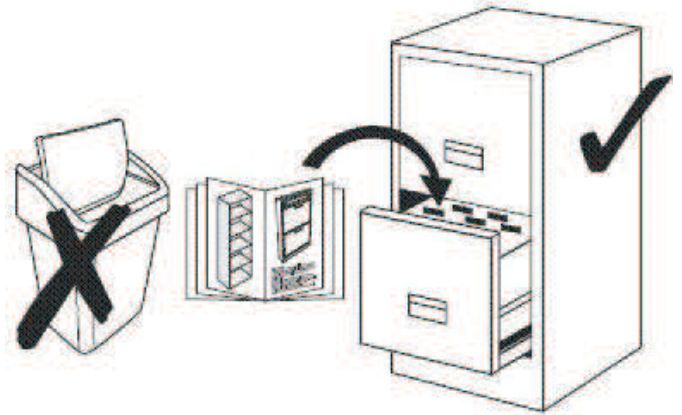
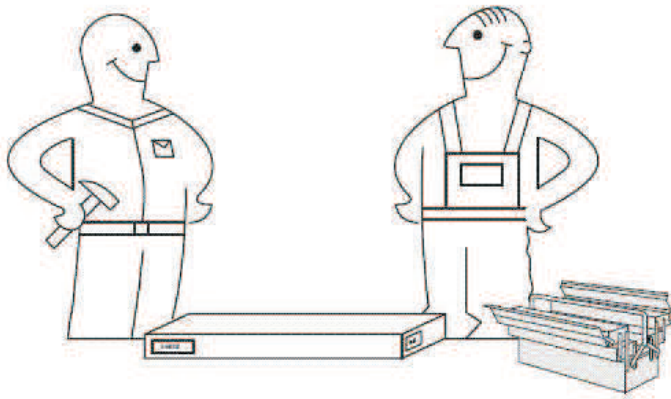

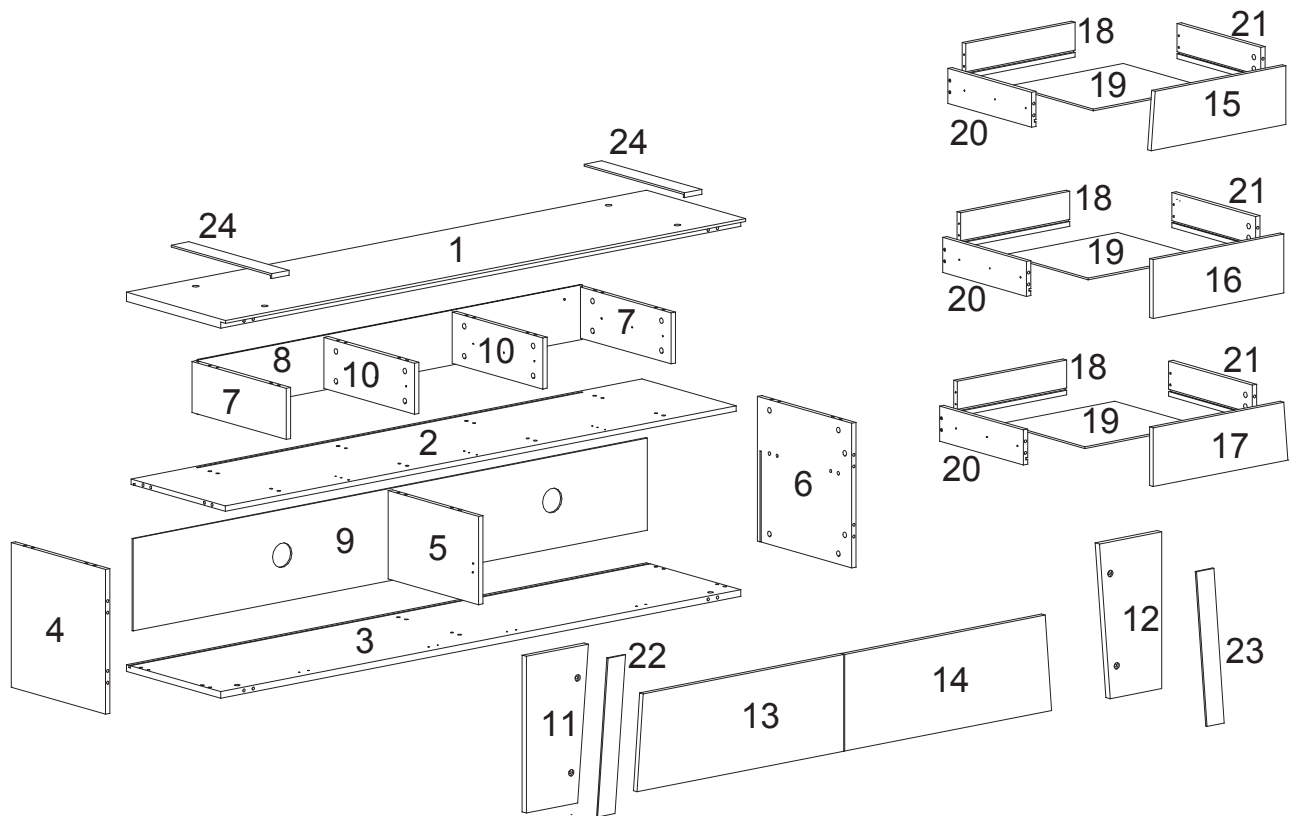



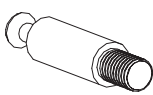
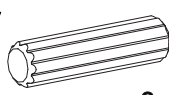

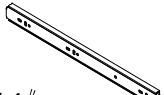

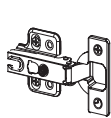

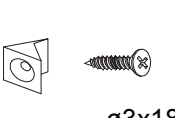
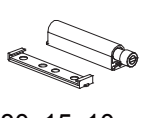



einschlagen yhammer in ybeverni ysla in
frapper au marteler yinfossare yZabit' y
zarazit уЗабийте И чукЗузabiti y
Introducere prin bataie узабить у



Drehenowenden yProsze odwrócić y
Kerenomdraaien yGirareRuotare y
Okrenutiubrnuti yRetournerenverser y
Turn overduim around уOtoctecobratte y
Обърнетесавъртет уObrnite list y
Intoarceți yrotiti yVrid runt cvänd y

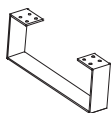

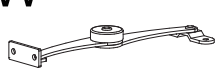
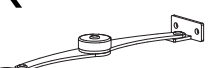

A  $\varnothing 15$ 52x	B  52x	C  $\varnothing 8 \times 30$ 40x	D  $\varnothing 3.5 \times 12$ 59x	E  14" 6x
F  $\varnothing 4 \times 30$ 12x	G  4x	H  $\varnothing 4 \times 14$ 24x	I  $\varnothing 3 \times 18$ 10x	K  80x15x10mm 5x
L  1x	M  $\varnothing 50 \times 3$ 4x	N  M6x15 22x	O  M6x25 4x	P  $\varnothing 20 \times 0.4$ 20x
Q  110x50x9 2x	R  $\varnothing 9 \times 2$ 2x	S  2x	T  $\varnothing 4 \times 50$ 2x	U  2x
V  1x	W  1x	X  1x	Y  $\varnothing 8 \times 12$ 18x	Z  2x

Step:1

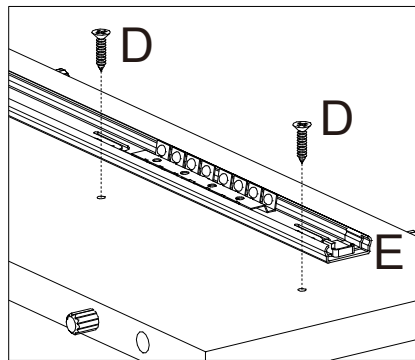
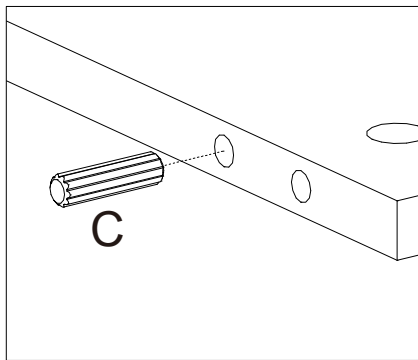
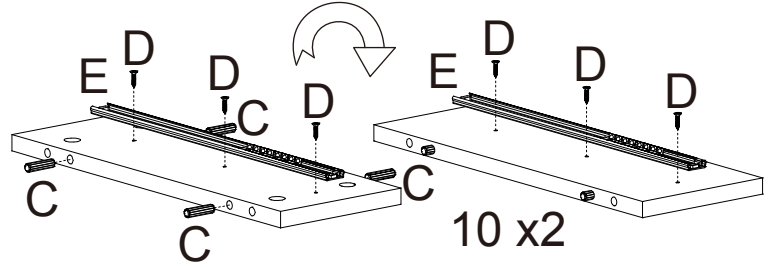
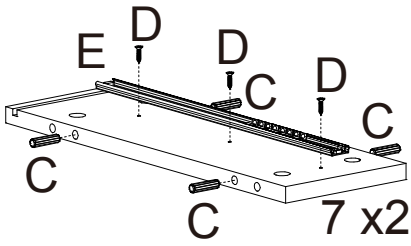
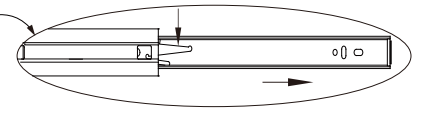
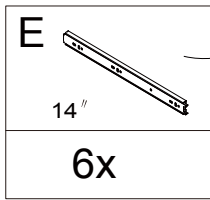
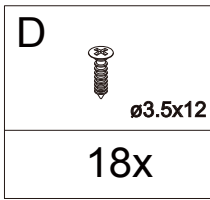
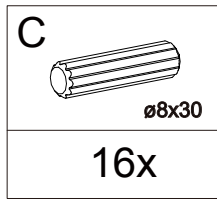

Step:2

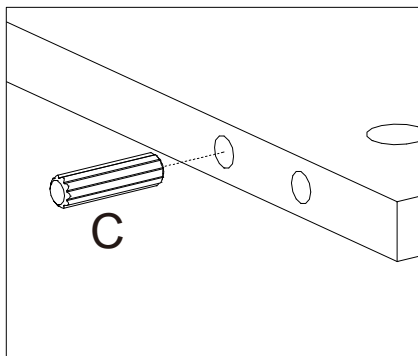
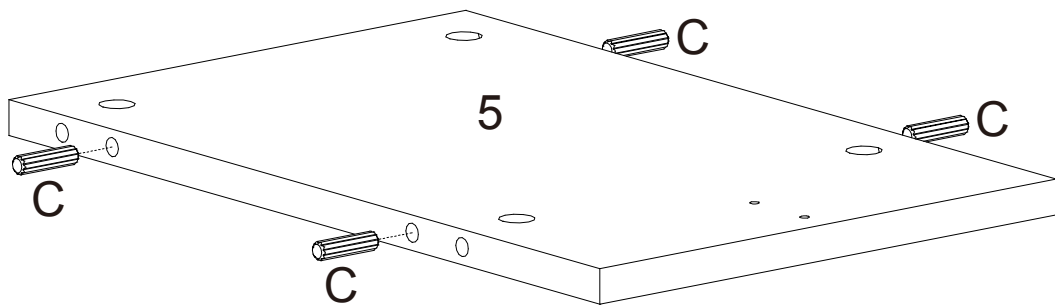
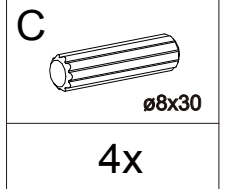

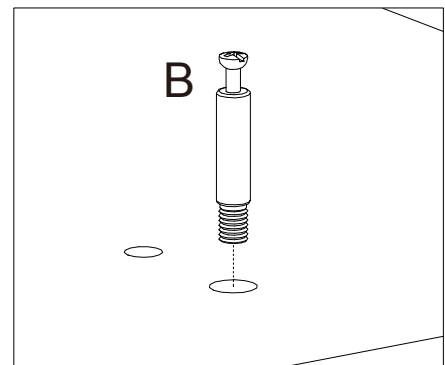
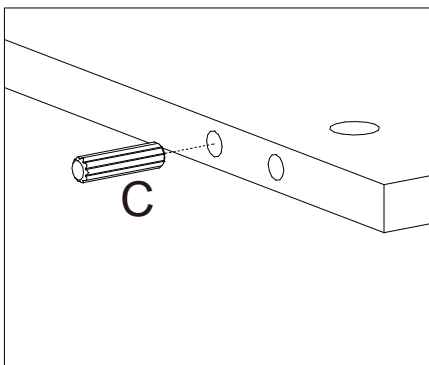
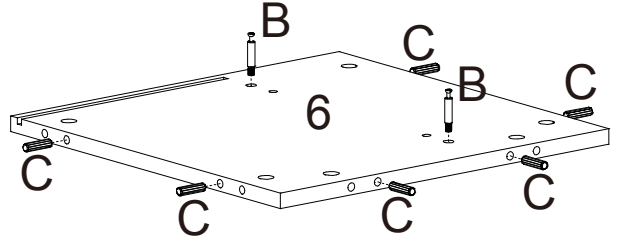
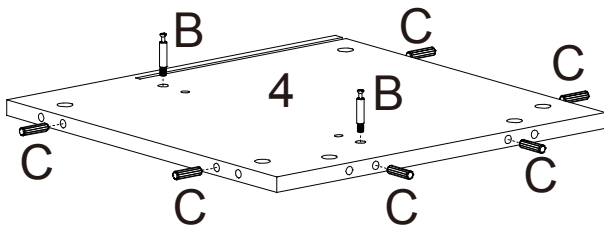
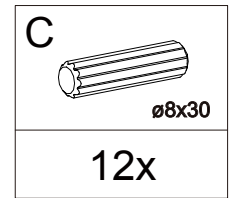
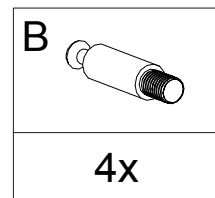

Step: 3

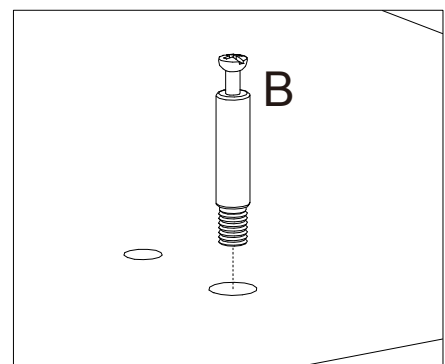
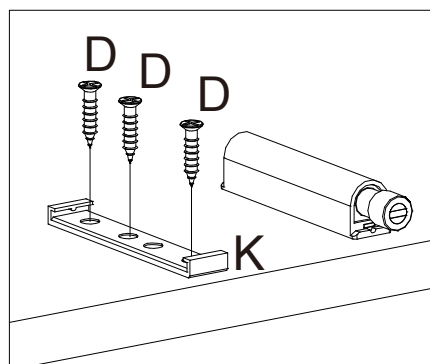
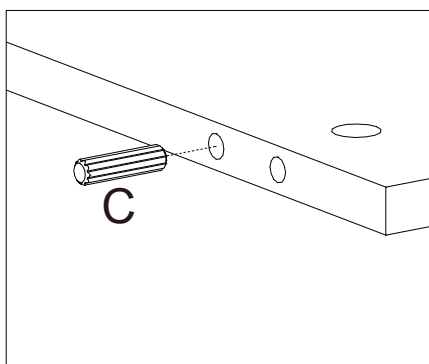
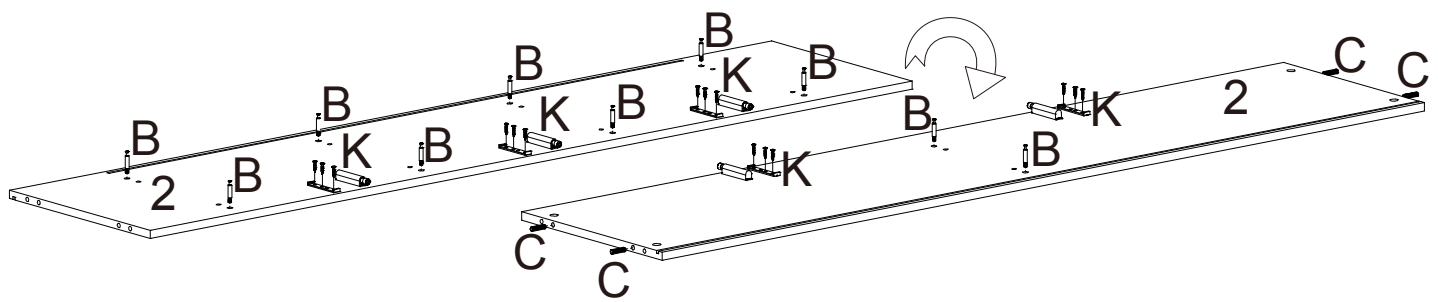
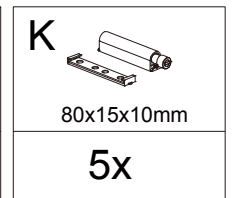
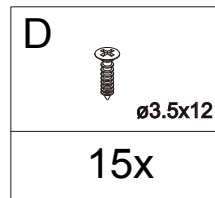
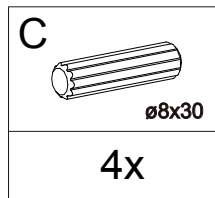
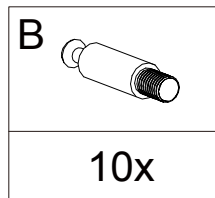

Step: 4



Step: 5

A	 ø15	P	 ø20x0.4
14x		2x	

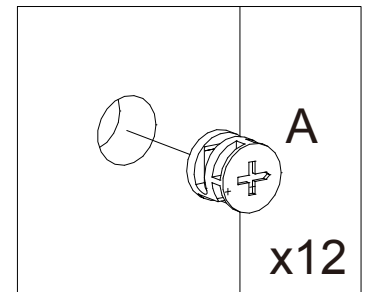
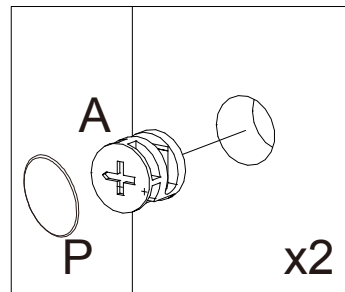
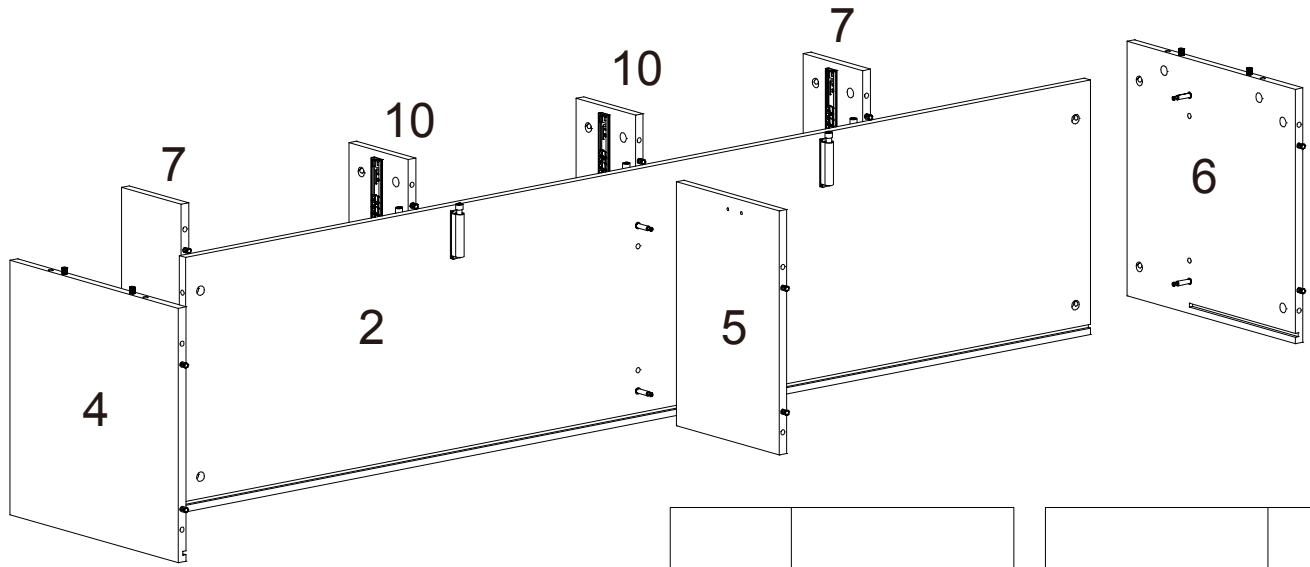





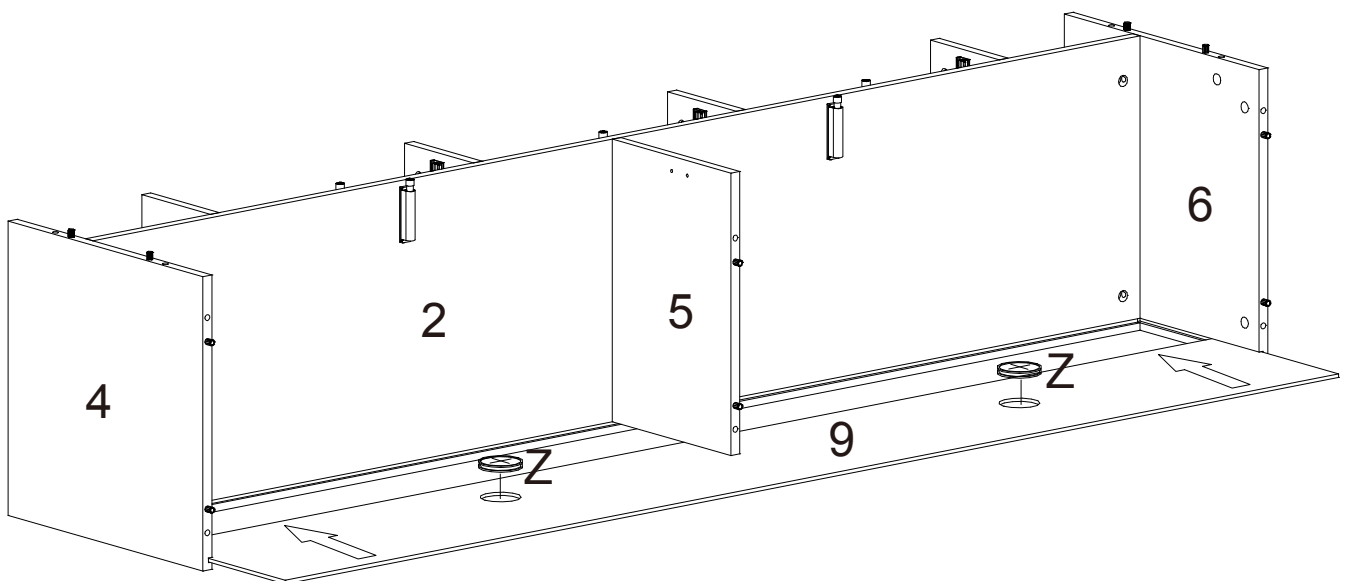

Step: 6

Z	
2x	



Step: 7

L		M	 ø50x3	N	 M6x15	U		V	
	1x		4x		18x		2x		1x
Y	 ø8*12								
	18x								

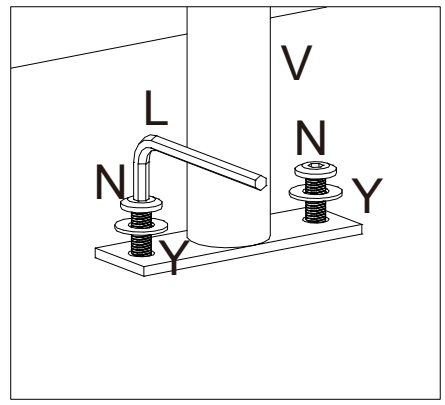
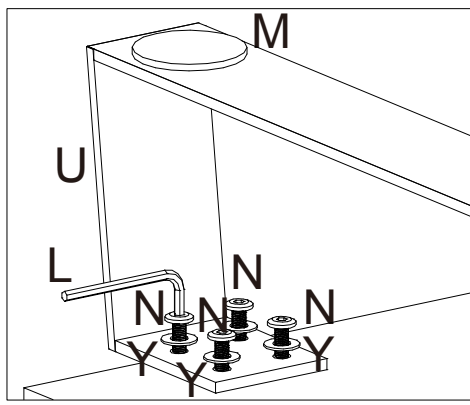
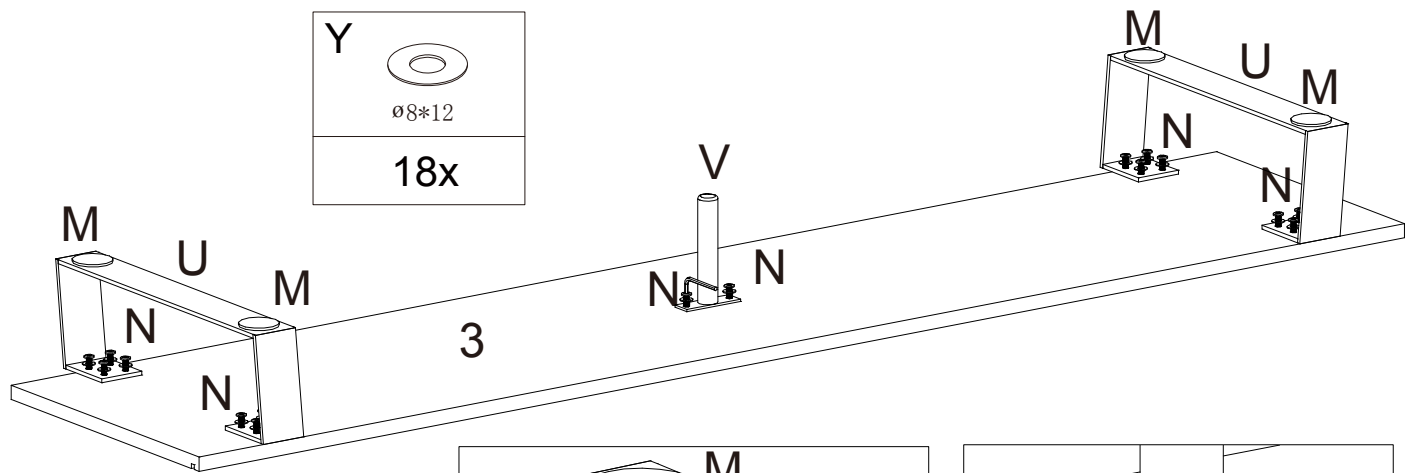

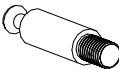
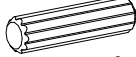

Step: 8

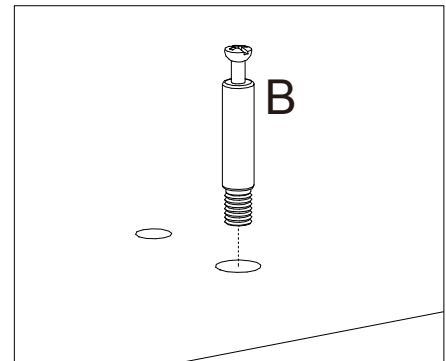
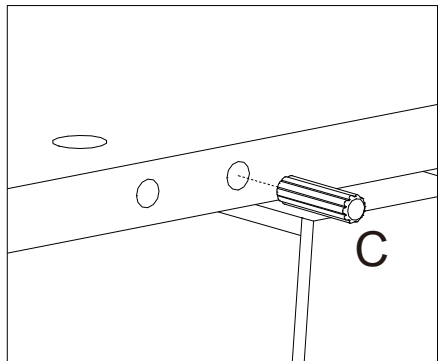
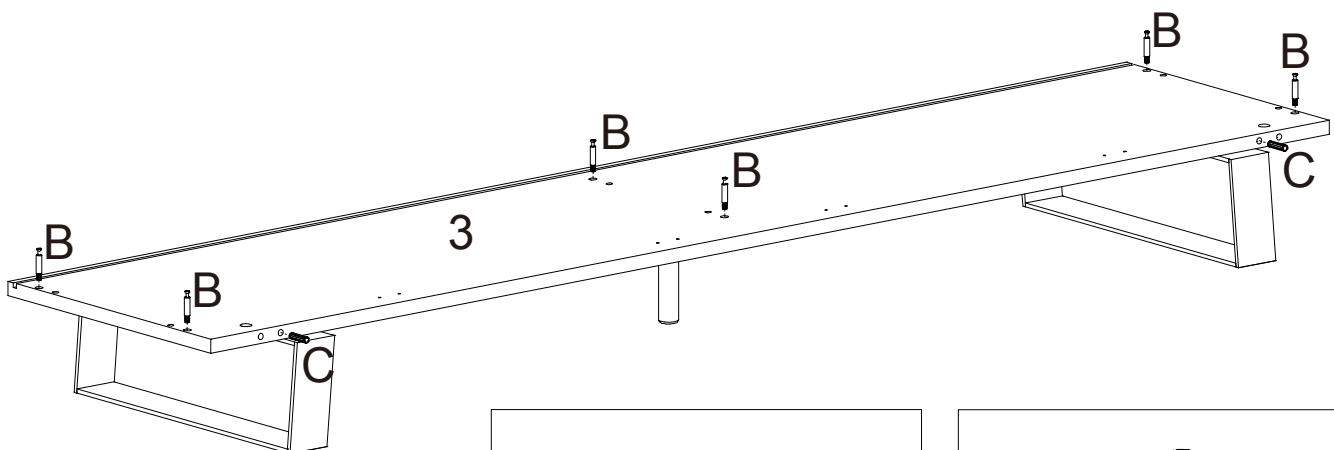
B		C	 ø8x30
	6x		2x



Step: 9

A  $\varnothing 15$	P  $\varnothing 20 \times 0.4$
6x	6x

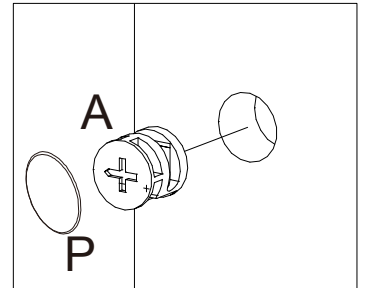
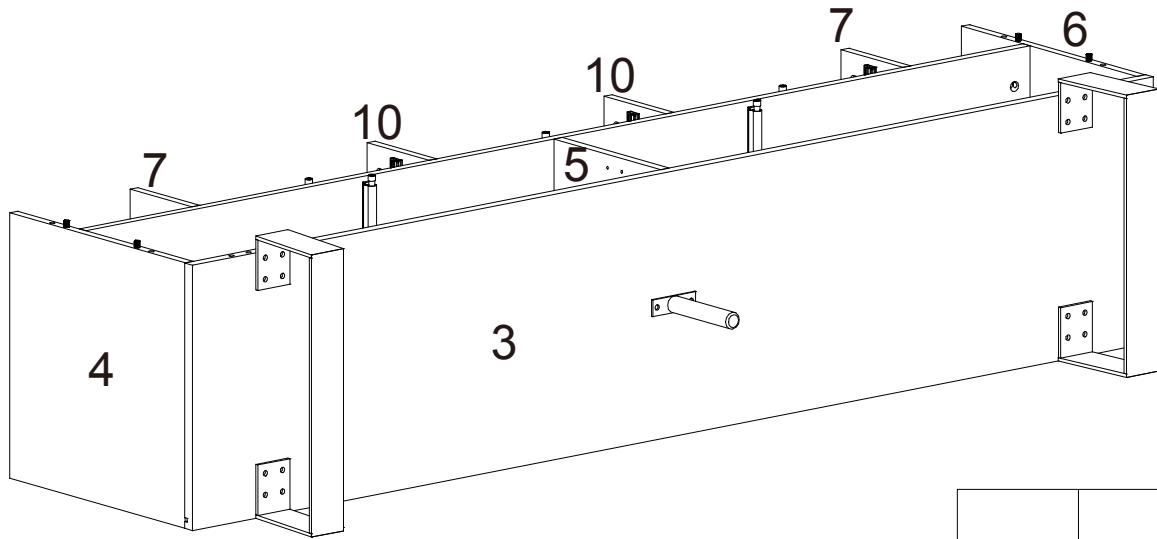

Step: 10

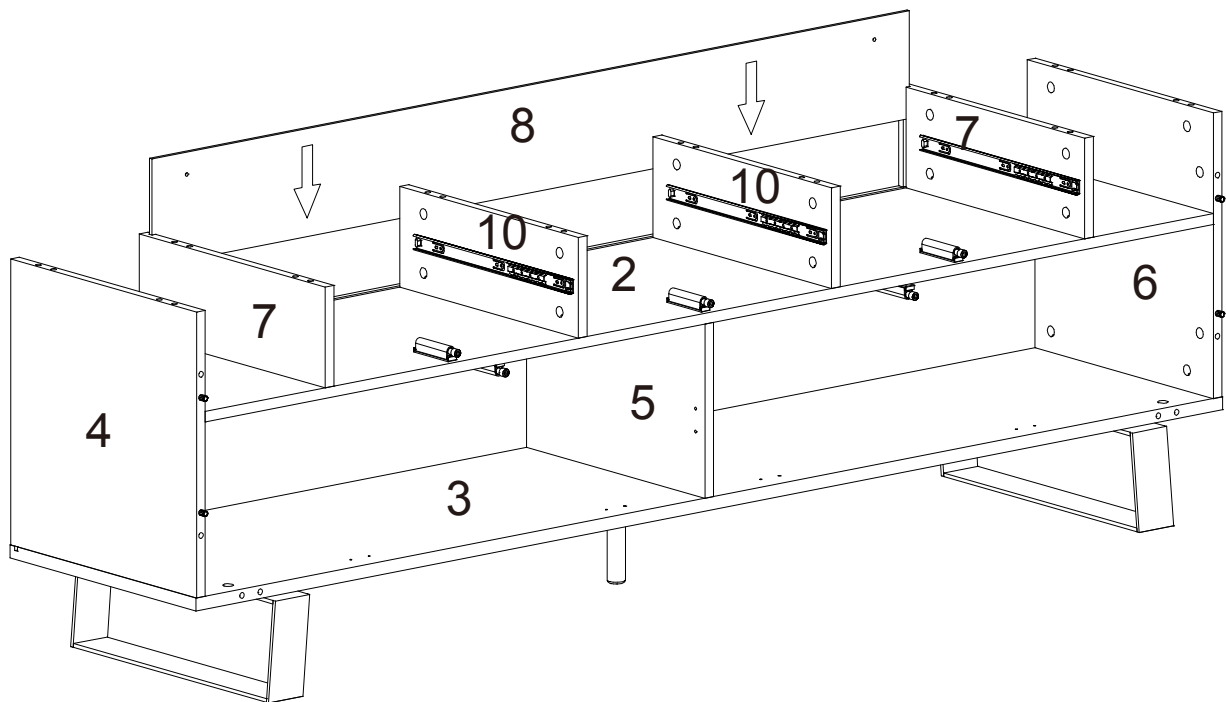

Step: 11

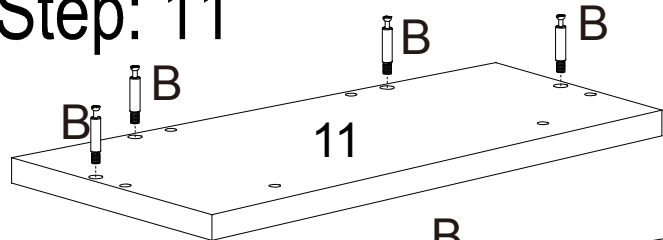

11

12

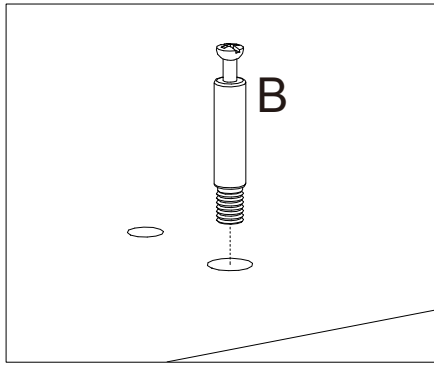
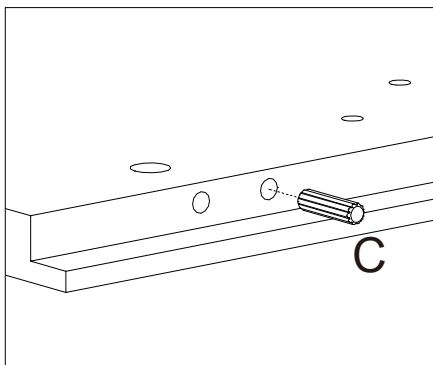
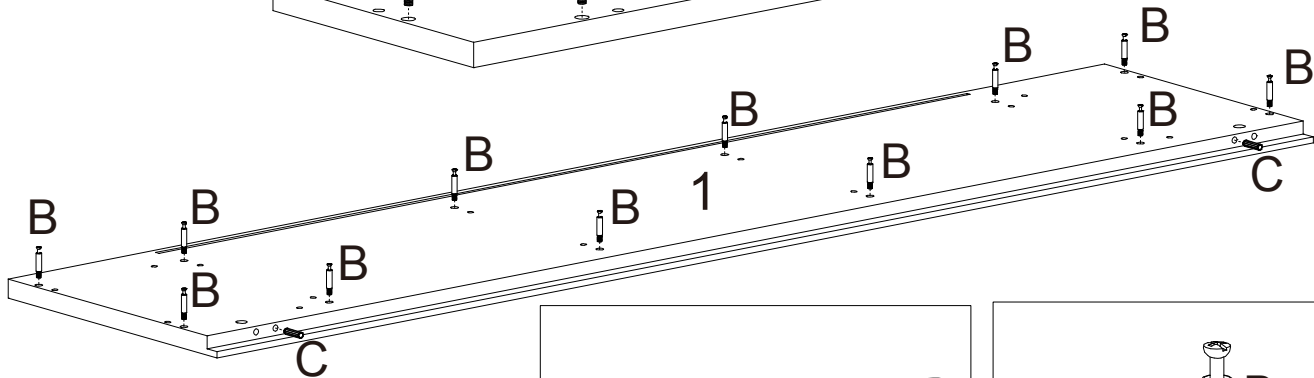
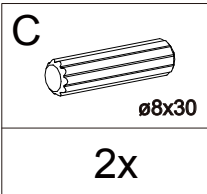
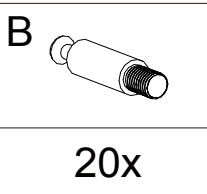

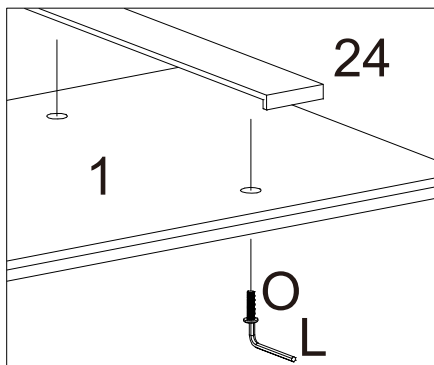
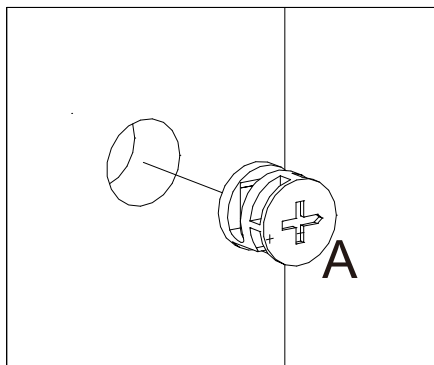
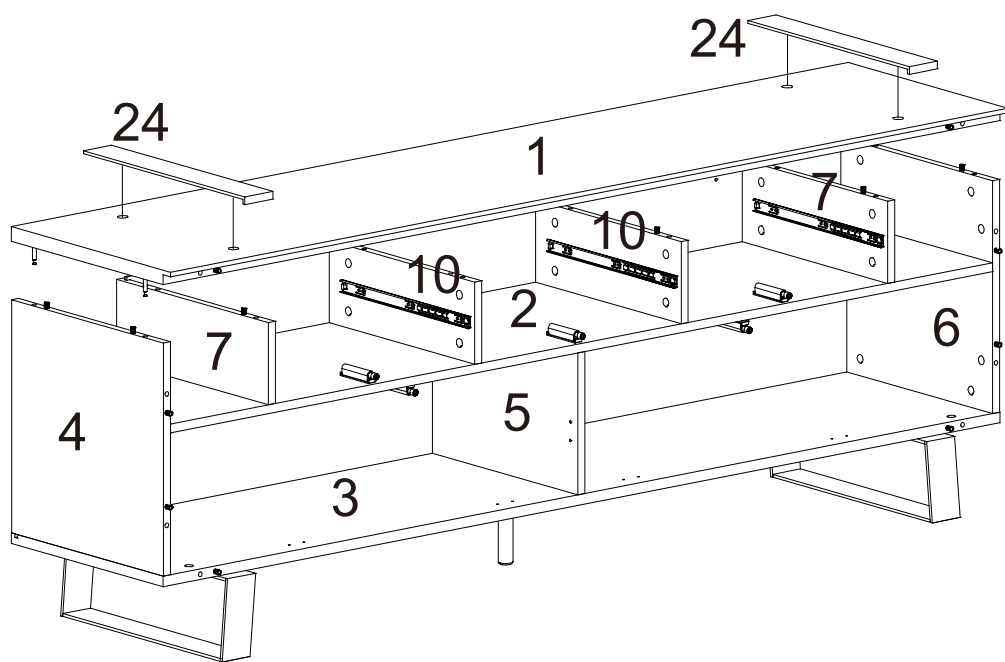
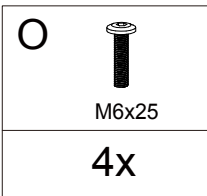
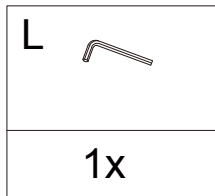
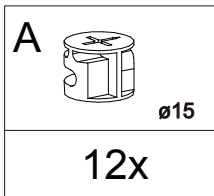

Step: 12



Step: 13

A	 ø15
8x	

L	
1x	

N	 M6x15
6x	

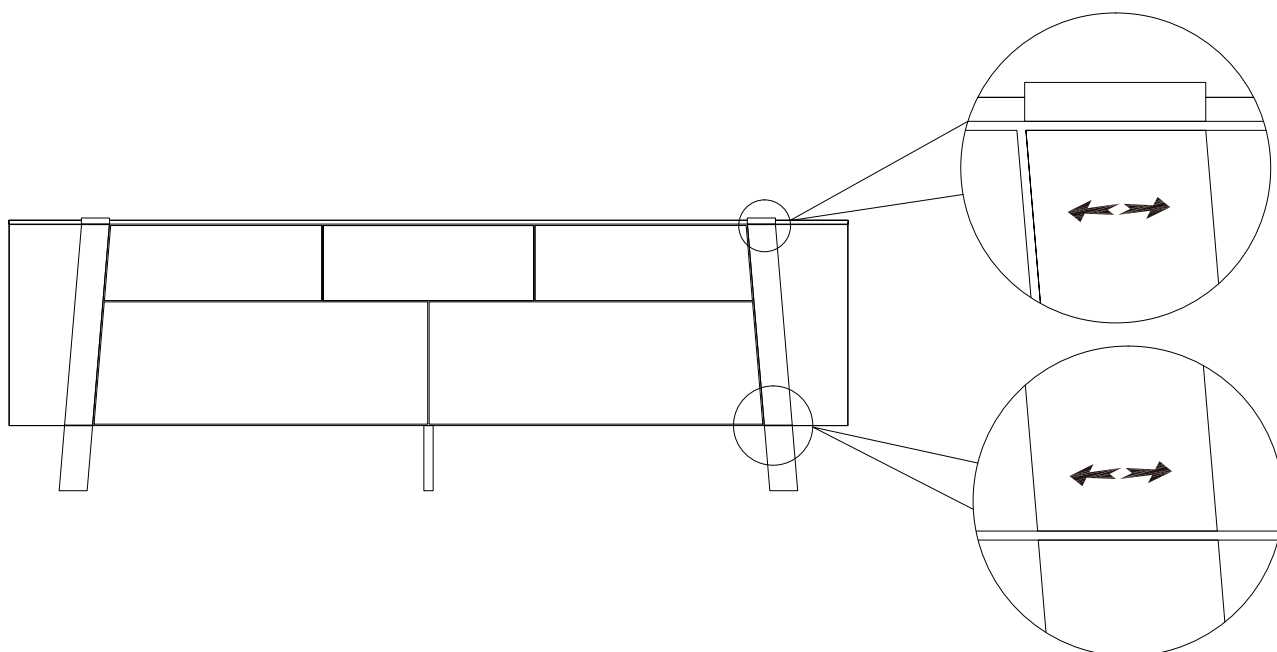
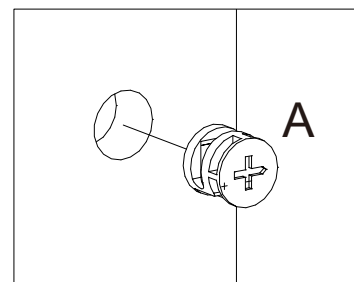
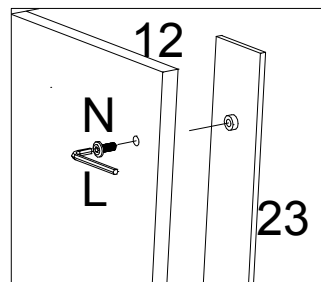
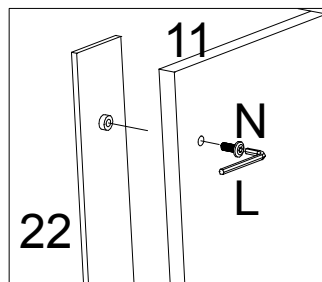
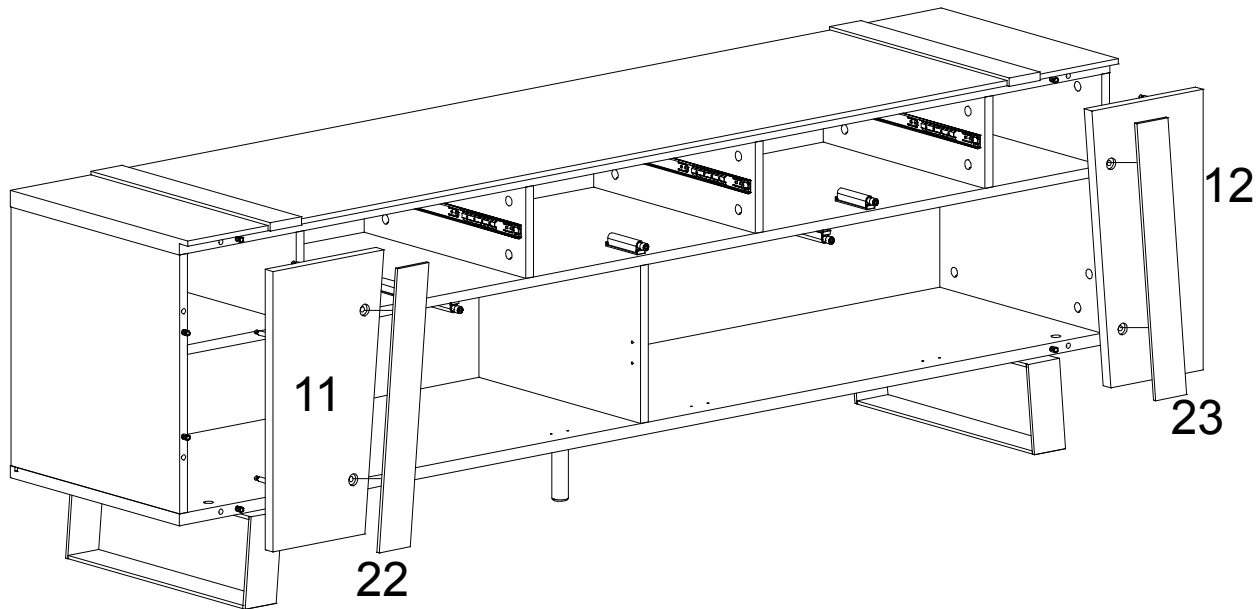

Step: 14

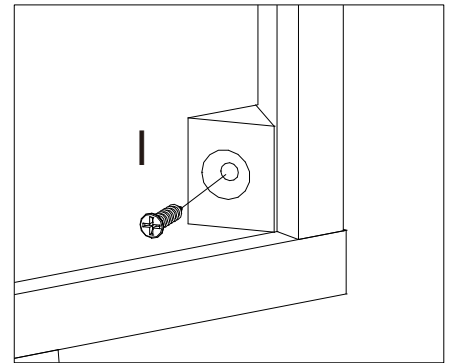
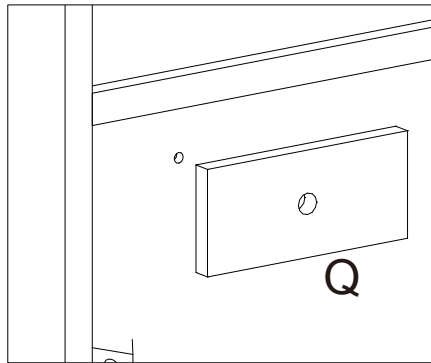
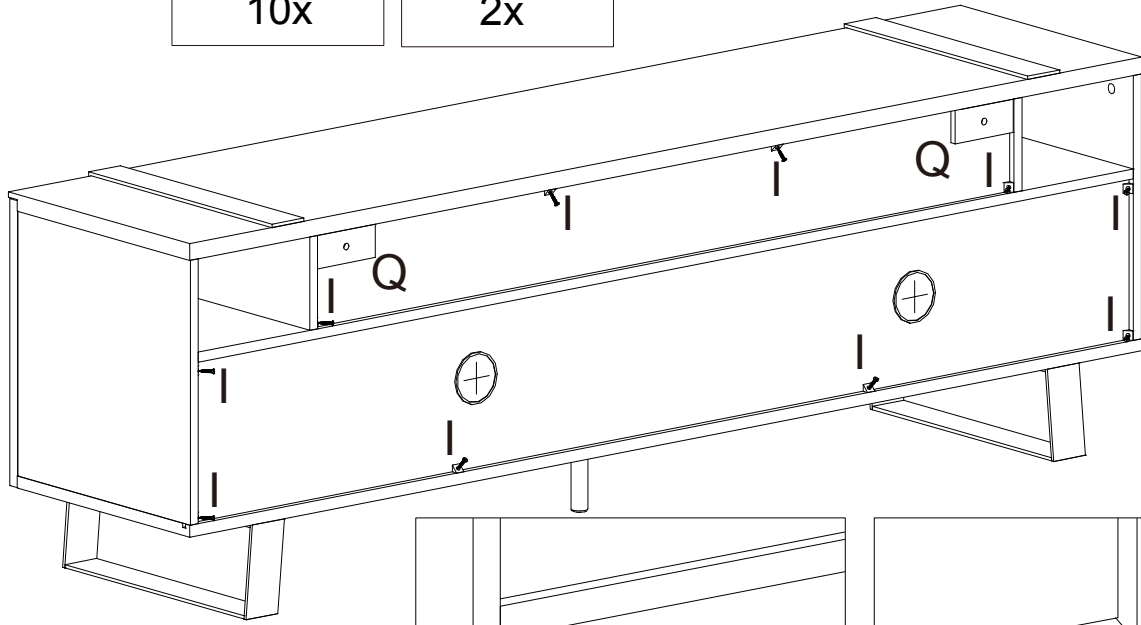
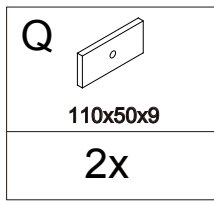
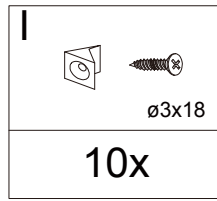

Step: 15

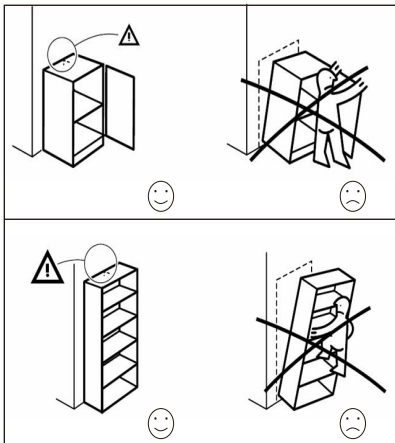
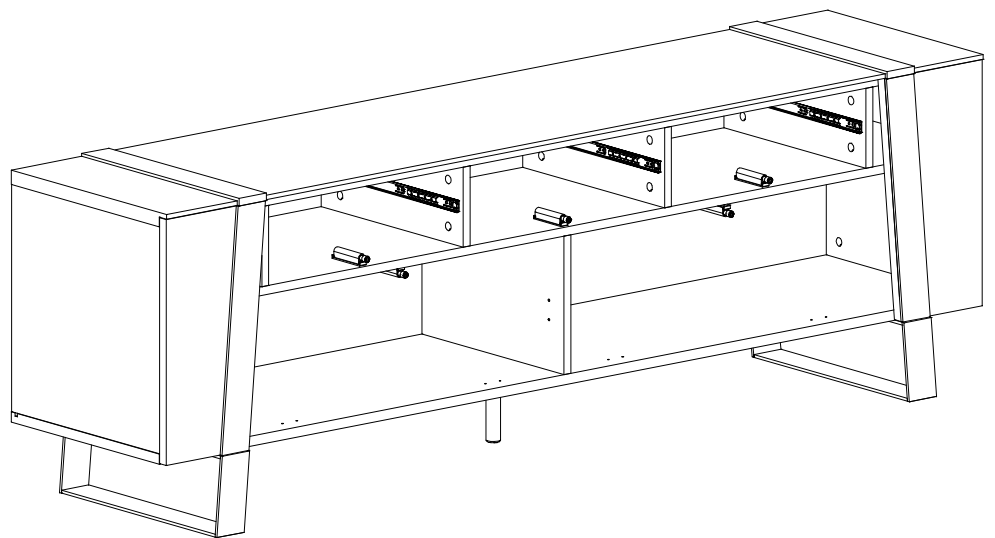
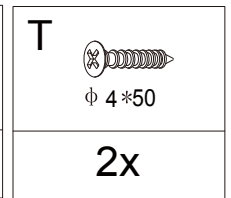
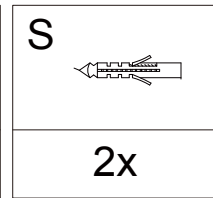
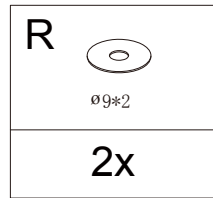
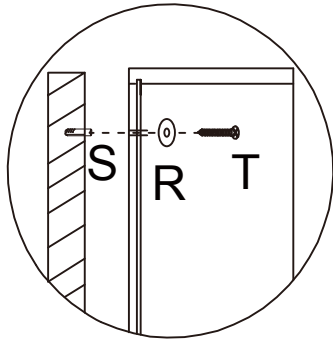

Step: 16

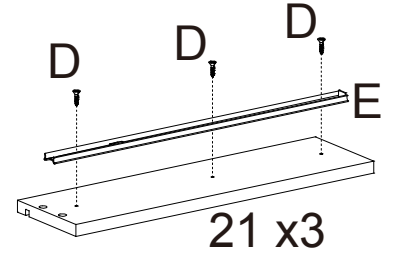
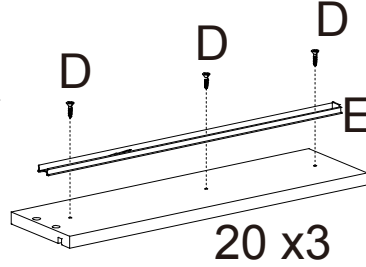
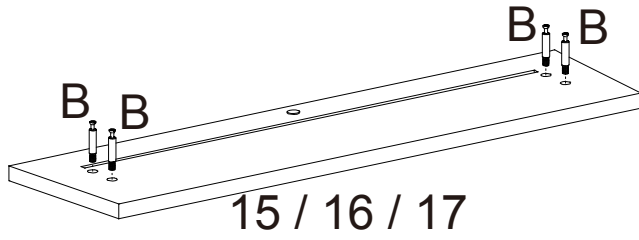
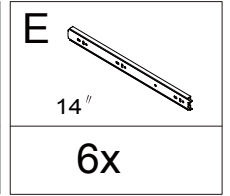
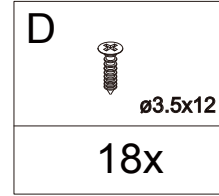
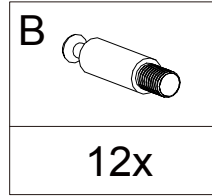

Step: 17

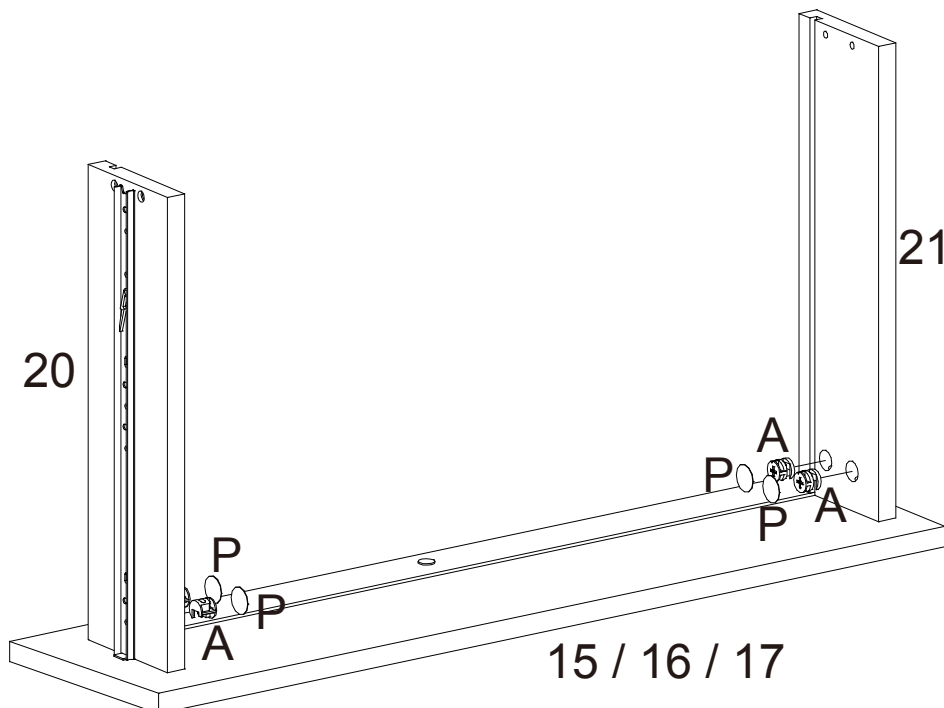
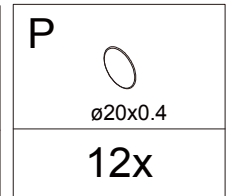
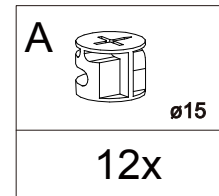

Step: 18

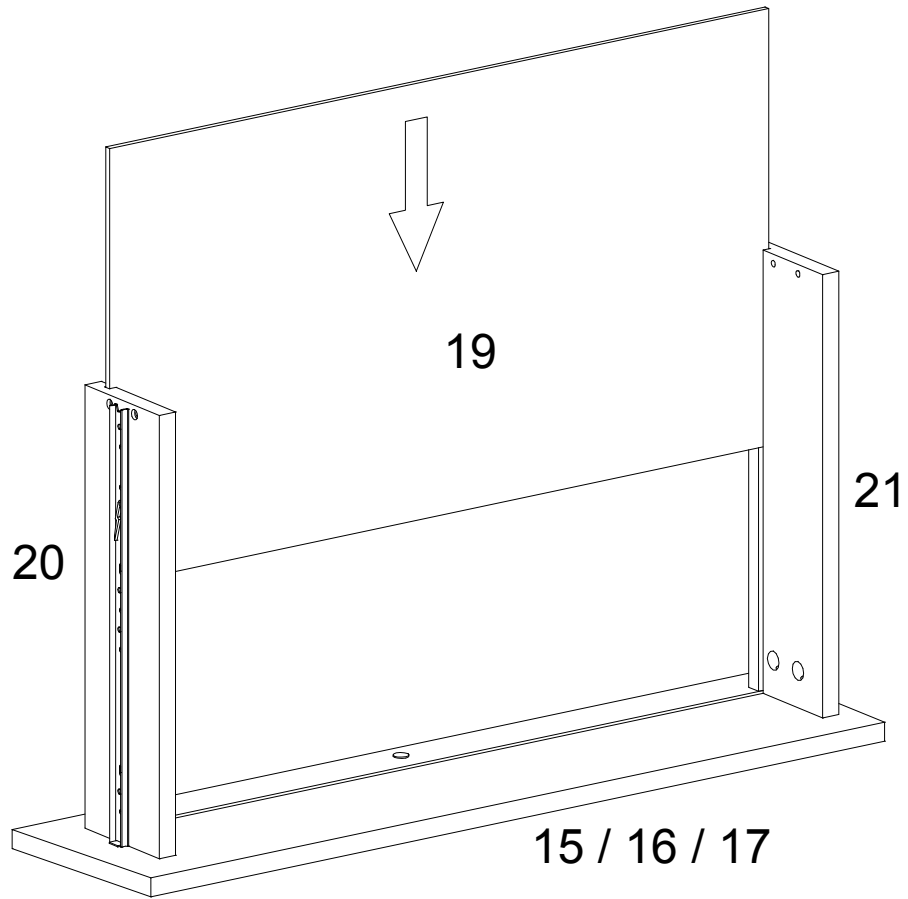

Step: 19

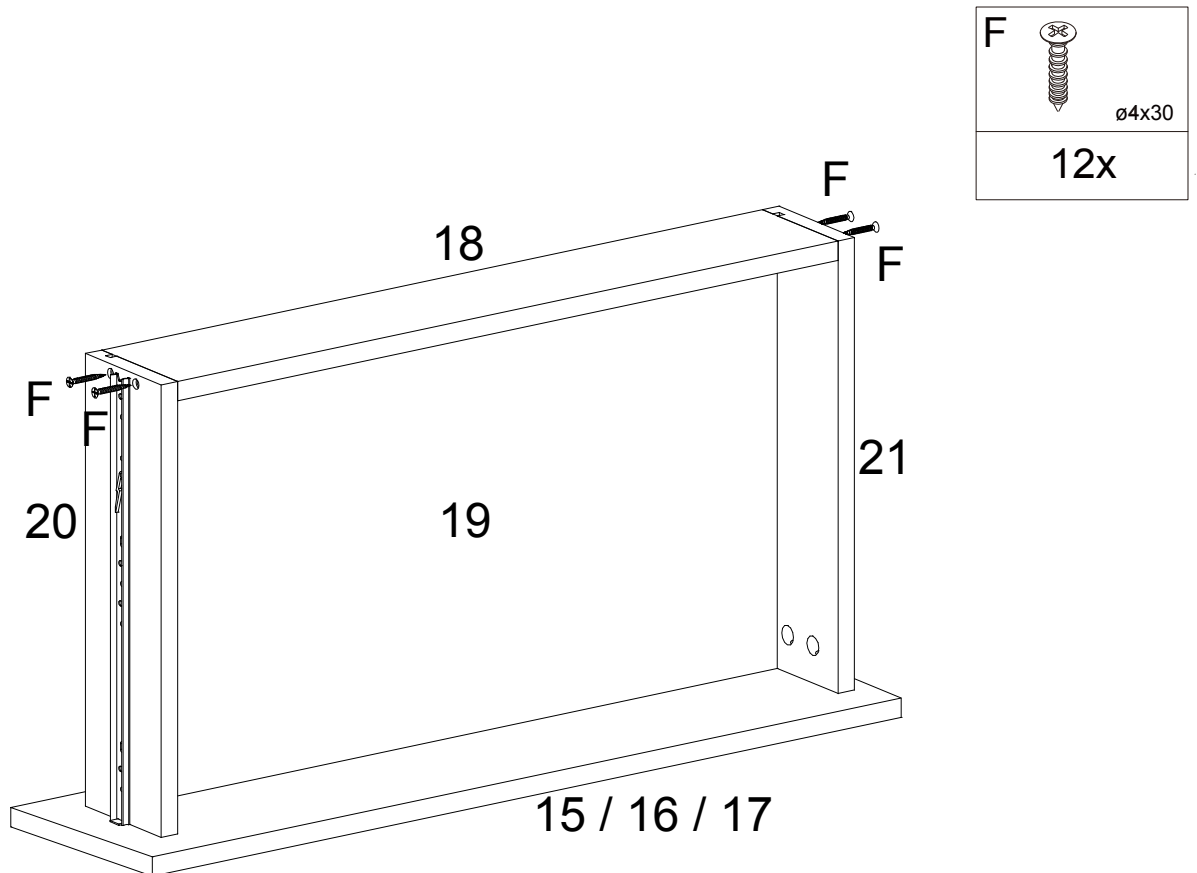

Step: 20

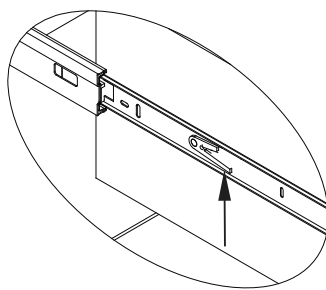
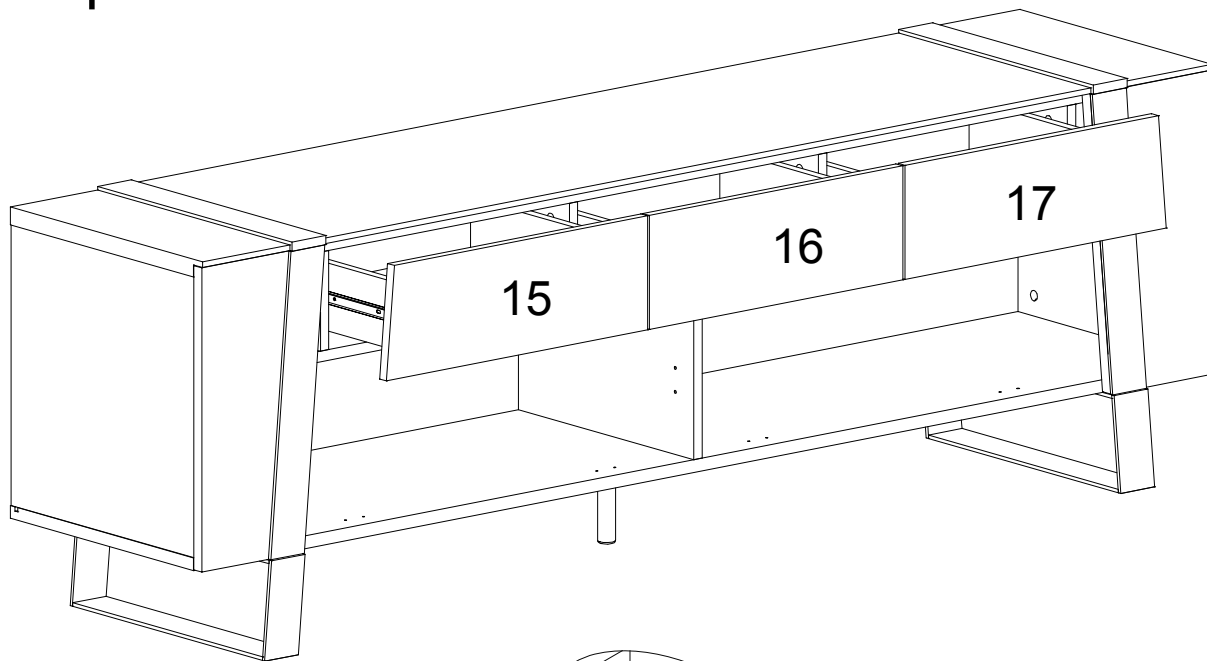

+

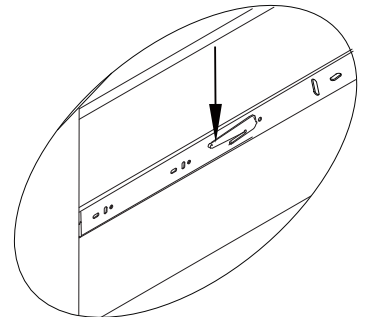

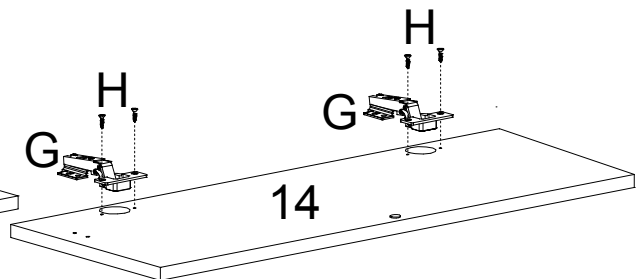
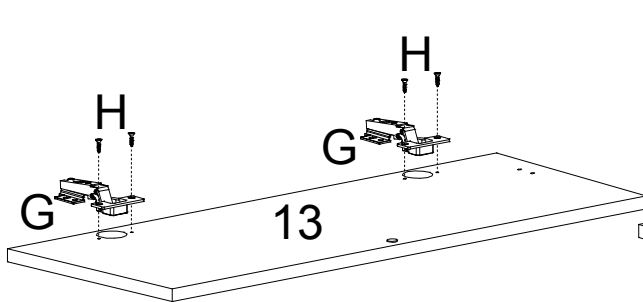
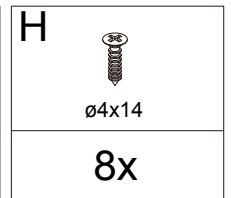
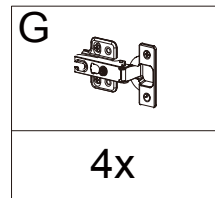

Step: 21

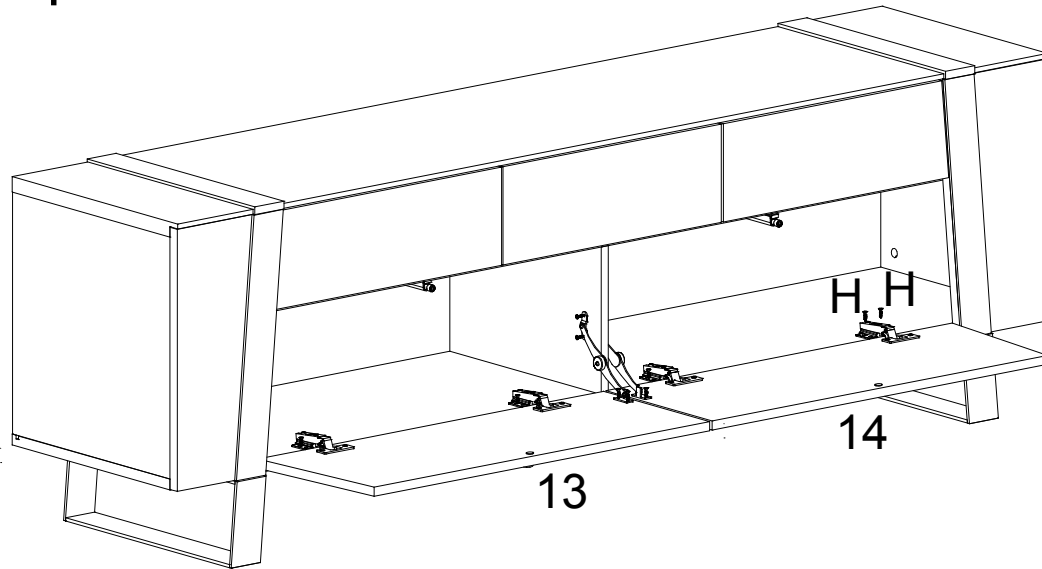

Step: 22



D

 ø3.5*12
8x

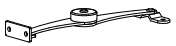
H

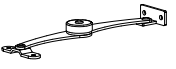
 ø4x14
8x

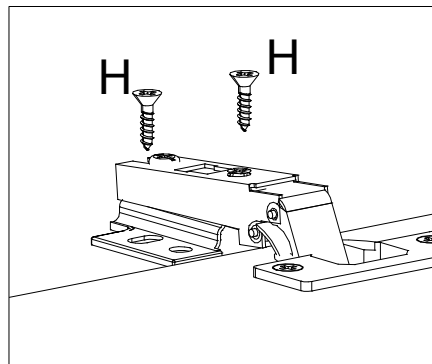
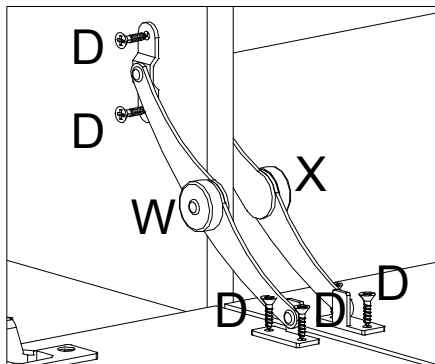
W

1x

X

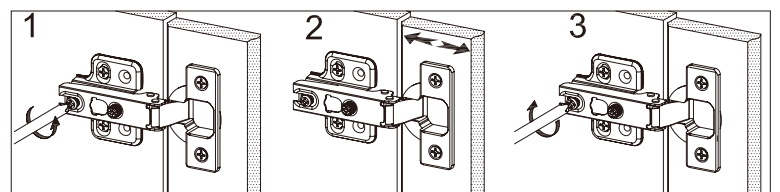
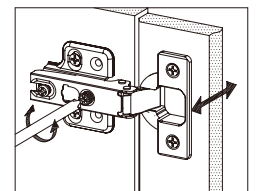
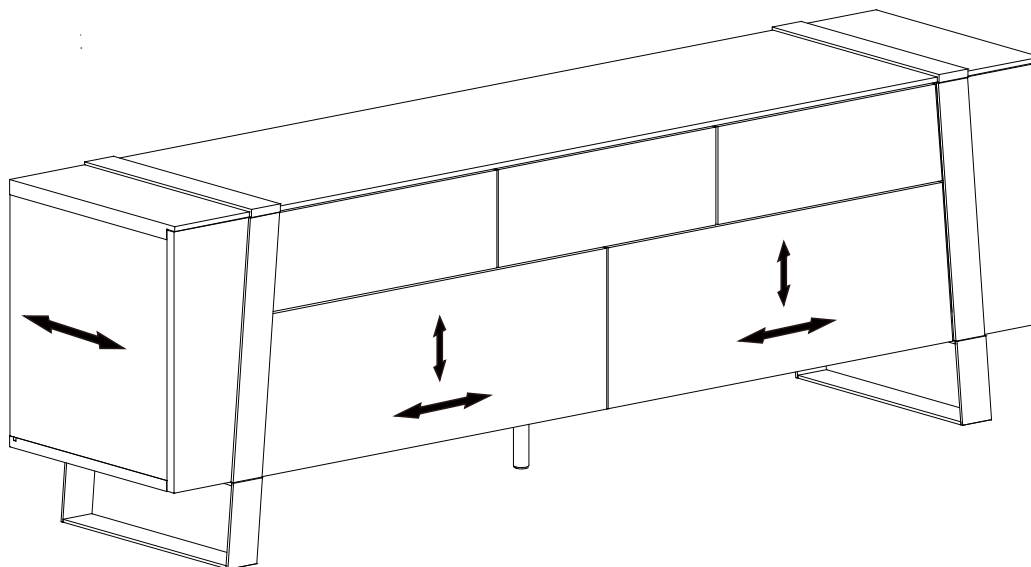
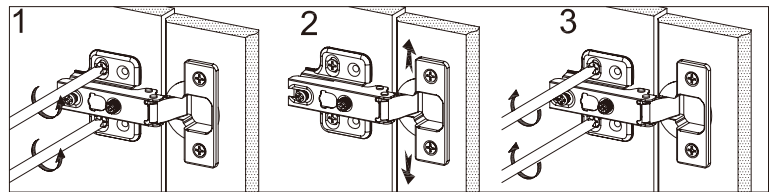
1x



Step: 23



Step: 24

H

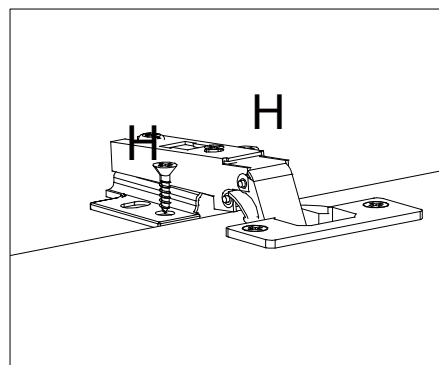
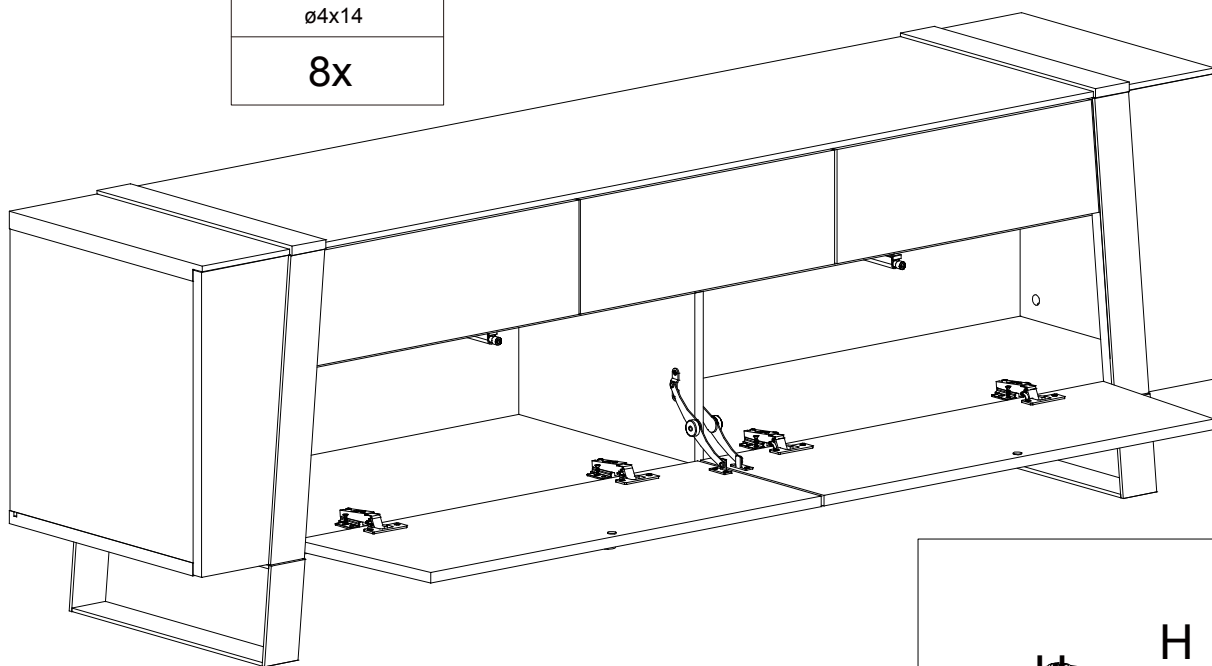
ø4x14
8x



Step: 25

