

Gebrauchsanleitung PK-Nr. 3274
Instructions / Mode d'emploi / Gebruiksaanwijzing /
инструкция по использованию / 使用说明

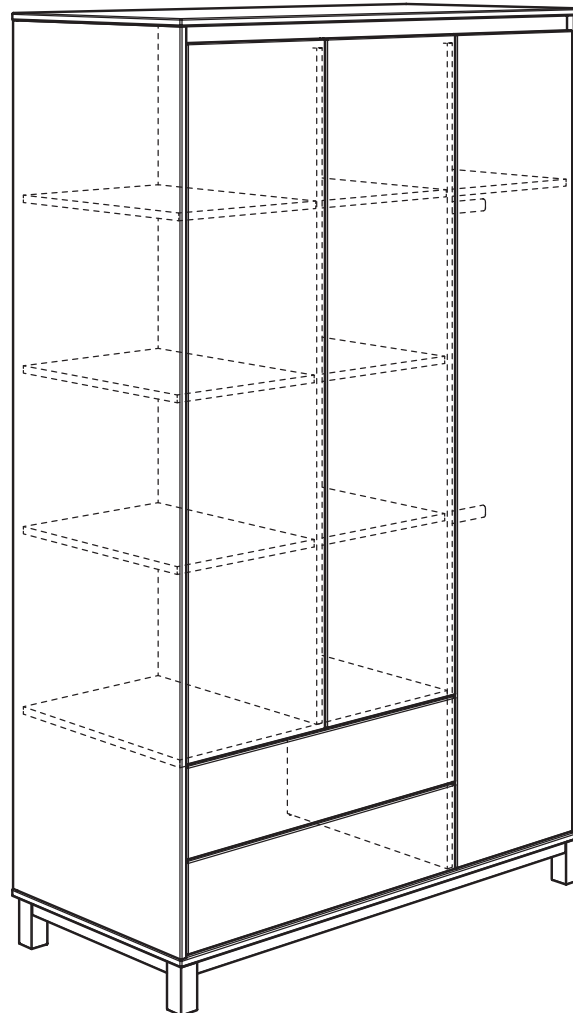

OLLI
Kreideweiss
168 1351

OLLI
Mattblau
168 1358

OLLI
Rose
168 1353

OLLI
Kieselgrau
168 1359





Warnhinweis!

Warning! / Avertissement! / Waarschuwing! /
Предупреждение! / 警告!



V..

Vorbereitung / Preparation /
Préparation / Voorbereiding /
Подготовка / 准备

M..

Montage / Assembly /
Assemblage / Montage / Монтаж /
组装

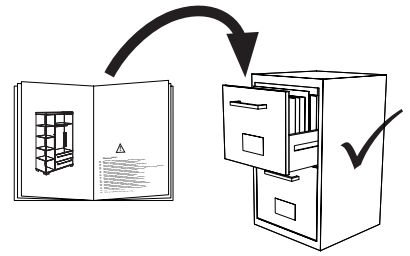

PK-Nr. 2800



Warnhinweis !

- DE Warnhinweis ! Beiliegende Wandbefestigungen müssen montiert werden !**
FR Attention ! Les fixations murales ci-jointes doivent être montées !
GB Attention ! The enclosed wall mountings must be fitted !
NL Let op ! De meegeleverde wandbevestigingen moeten worden gemonteerd !
ES ¡Atención! Las fijaciones murales incluidas deben montarse !
GR Προσοχή ! Τα εξαρτήματα στήριξης που περιλαμβάνονται στη συσκευασία πρέπει να συναρμολογηθούν !
IT Attenzione ! Occorre montare i fissaggi per attacco alla parete qui allegati !
CZ Pozor ! Příložené úchytky musí být namontovány na stěnu !
SL Pozor ! Namontirati je potrebno priložene elemente za pritrnitev na zid !
PL Uwaga ! Załączone zamocowania do ściany muszą być zamontowane !
BG Внимание ! Приложениете закрепвания за стена трябва да бъдат монтирани !
HR Pozor ! Priložena zidna pričvršćenja moraju biti montirana !
LT Dėmesio ! Priedamas tvirtinimo prie sienos detales reikia sumontuoti !
RU Внимание ! Обязательно используйте прилагаемые крепления стене !
CN 注意 ! 附带的墙壁安装组件必须安装 !
AR تنبه! لا بد من تركيب الأدوات المرفقة للتثبيت على الحائط!
- DE Schraubenverbindungen von Zeit zu Zeit auf ihre Festigkeit prüfen, gegebenenfalls nachziehen, da die Stabilität der Konstruktion sonst nicht gegeben ist.**
FR Vérifier les connexions à vis de temps en temps, resserrer celles-ci le cas échéant, car, sinon, la stabilité de la construction ne serait pas assurée.
GB Check the tightness of the screw connections from time to time and tighten if necessary, as otherwise the stability of the construction is not assured.
NL Schroefverbindingen moeten van tijd tot tijd op hun stevigheid worden gecontroleerd en eventueel worden vastgedraaid, aangezien de stabiliteit van de constructie anders niet verzekerd is.
ES Compruebe de vez en cuando la firmeza de las uniones atornilladas y reapriete los tornillos si fuera necesario, pues de lo contrario quedaría afectada la estabilidad de la estructura.
GR Πού και πού ελέγχετε τη σταθερότητα των κοχλιωτών συνδέσεων κι εφ' όσον είναι ανάγκη, τις σφίγγετε ξανά, επειδή διαφορετικά δεν είναι η ευστάθεια της κατασκευής δεδομένη.
IT Controllare di tanto in tanto la tenuta delle connessioni a viti, all'occorrenza provvedere a serrarle di nuovo, poiché altrimenti non è garantita la stabilità della struttura.
CZ Čas od času zkontrolujte pevnost šroubových spojů, případně je dotáhněte, jinak nebude konstrukce stabilní.
SL Vijačne zveze od časa do časa preveriti glede na trdnost, po potrebi priviti, saj sicer stabilnost konstrukcije ne bo zagotovljena.
PL Połączenia śrubami sprawdzać od czasu do czasu pod kątem ich trwałości, ewentualnie dokręcać, gdyż inaczej konstrukcja nie jest stabilna.
BG Контролирайте от време на време дали болтовите съединения са добре завинтени, тъй като в противен случай не може да се гарантира стабилността на конструкцията.
HR Spojeve vijaka s vremena na vrijeme provjeriti u svezi čvrstoće, po potrebi stegnuti, jer inače nije zajamčena stabilnost konstrukcije.
LT Kartais patikrinkite varžtų jungčių stiprumą, prireikus suveržkite juos stipriau, nes priešingu atveju konstrukcija nebus stabilii.
RU Перепроверяйте время от времени болтовые соединения. Они должны быть плотно затянуты. Это гарантирует стабильность конструкции.
CN 请经常的检查连接处的螺丝，如有发现松动请及时锁紧，否则将无法保障其稳定性。
- DE Pflegehinweis: Zum Reinigen der Oberflächen ein leicht-feuchtes Tuch oder ein handelsübliches Möbelpflegemittel verwenden.**
FR Indication sur l'entretien: pour nettoyer les surfaces, utiliser un chiffon légèrement humide ou un nettoyant pour meubles en vente dans le commerce
GB Caring for the... : In order to clean the surfaces please use a slightly damp cloth or commercially available furniture care product.
NL Verzorgingsaanwijzing: Voor het reinigen van de oppervlakken een licht vochtig doek of een gebruikelijk meubelschoonmaakmiddel gebruiken.
ES Recomendaciones de cuidado: Para limpiar las superficies del mueble debe usar un trapo humedecido o un producto de limpieza de muebles comercial.
GR Οδηγίες περιποίησης: Για το καθάρισμα των επιφανειών να χρησιμοποιείτε ένα ελαφρά νοτισμένο πανάκι ή λούστρο επίπλων.
IT Indicazione per pulizia e cura: Per la pulizia delle superfici utilizzate un panno leggermente umido o un normale prodotto per la cura dei mobili.
CZ Pokyny k čištění: Na čištění povrchu použijte pouze navlhčený kousek látky nebo běžný prostředek na ošetřování nábytku.
SL Navodilo za nego: Za čiščenje površin uporabljajte malo vlažno čunjo ali trgovsko običajno sredstvo za nego pohištva.
PL Wskazówka pielęgnacyjna: do czyszczenia powierzchni stosować lekko wilgotną ściereczkę lub zwykły środek do pielęgnacji mebli.
BG Указание за поддържане: Използвайте леко навлажнена кърпа или обикновен препарат за поддържане на мебели, за да почистите повърхностите.
HR Upute za njegu: Za čišćenje površina upotrijebiti jednu lako navlaženu krpu i trgovačko uobičajeno sredstvo za njegu namještaja.
LT Rekomendacija priežiūrai: Paviršius valykite drėgna pašluoste arba parduotuvėse įsigytomis baldų priežiūros priemonėmis.
RU Рекомендации по уходу: для очистки поверхностей используйте слегка влажную тряпку или обычное средство по уходу за мебелью.
CN 保养说明: 清洁表面只需用稍微潮湿的布或普通的家具清洁剂即可。
AR إرشاد للعناية: يرجى من أجل تنظيف الأسطح استخدام منديل رطب بعض الشيء أو استخدام إحدى مواد تنظيف الأثاث المتوفرة في الأسواق التجارية.

Beschläge

Fittings / Raccords / Hulpstukken /
Фурнитура / 配件

1:1
DIN A4

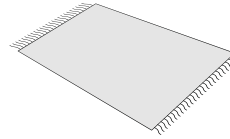
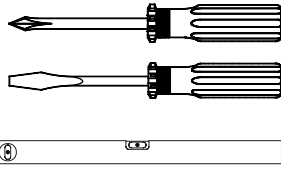
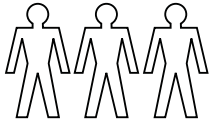
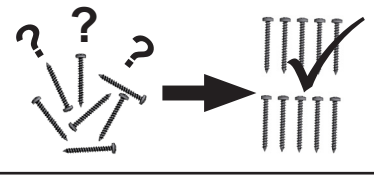
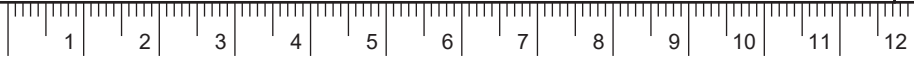

ca. 1,6h

A 16x 681 0759	B 2x 681 0757	C 4x 681 1645	D 3,5 x 13 4x 681 4887	E 5x 681 0760	F 8x 681 8126	G 8x 681 8137	H 1x 681 8405
I 1x 681 8406				J 3x 681 2894		K 7x 681 2895	
L 10x 681 2888	M1 3x 681 7326	M2 3x 681 8027	N 3,0 x 13 6x 681 4705	O 8x 681 2497	P 6,3 x 15 8x 681 5060	Q 16x 681 0350	
R 12x 681 2498	S 2x 681 3314	T 2x 681 3315	U 6,3 x 14 8x 681 5097	V1 4x 681 8701	V2 Sockelprofil Länge: 1141mm 2x 681 8706	V3 Sockelprofil Länge: 449mm 2x 681 8717	
V4 4 x 35 16x 681 5001	V5 4,0 x 20 8x 681 4917	X Weiss white 14x 683 0101	Y Weiss white ø10 x 15 1x 683 0051	Z 13x 681 2852			

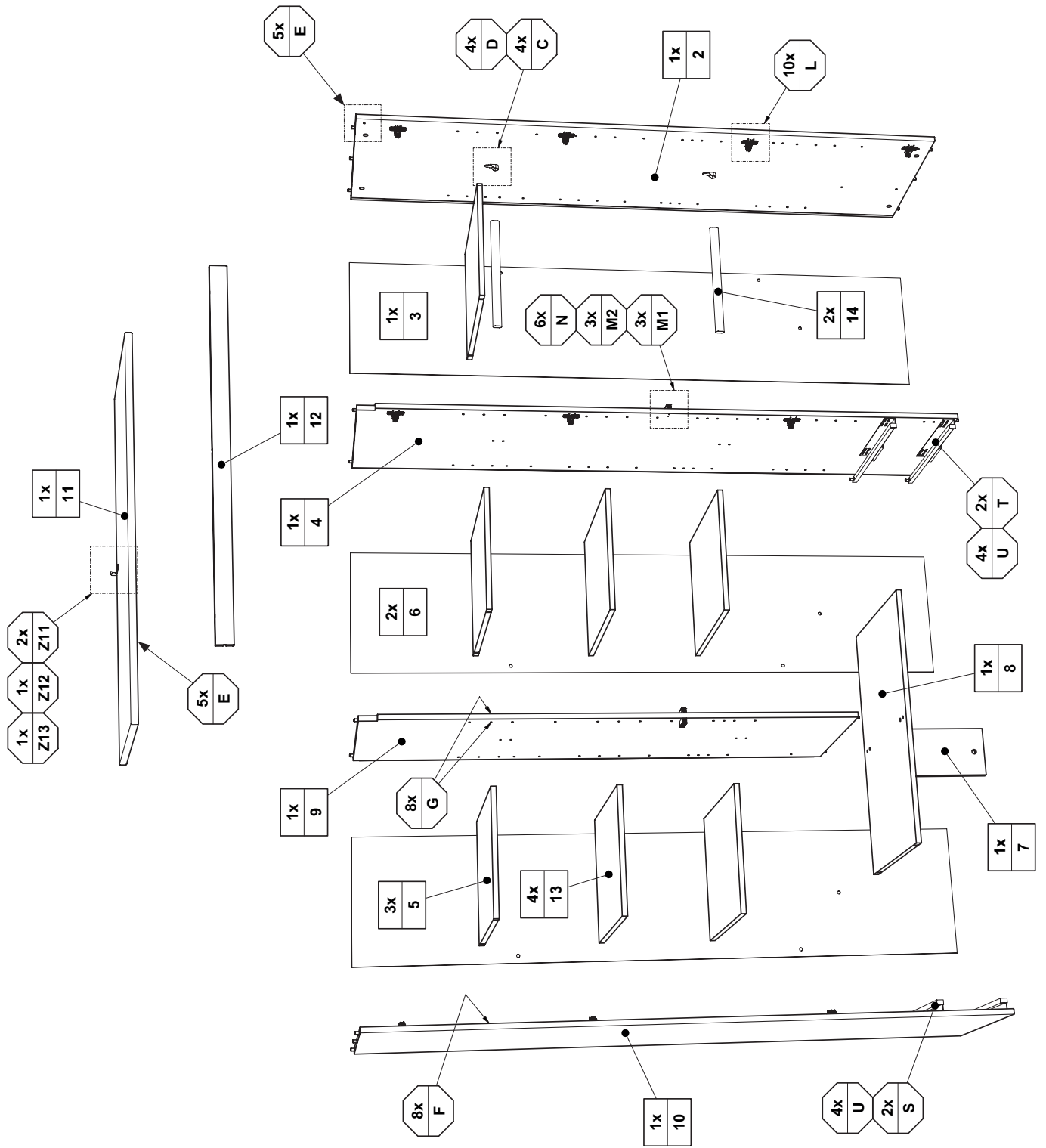

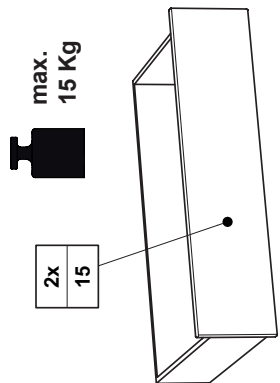
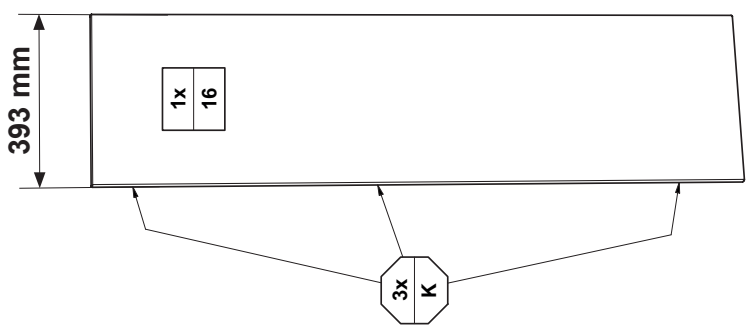
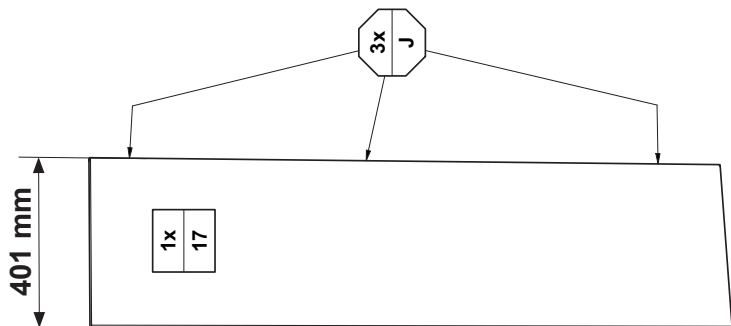
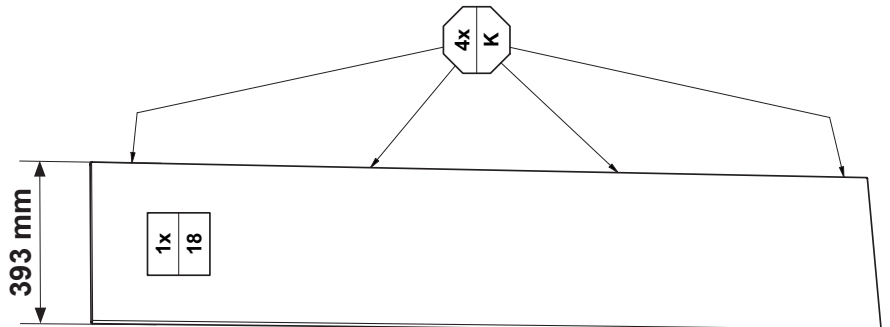
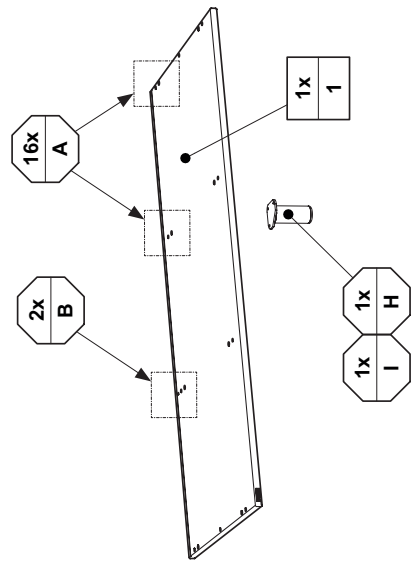
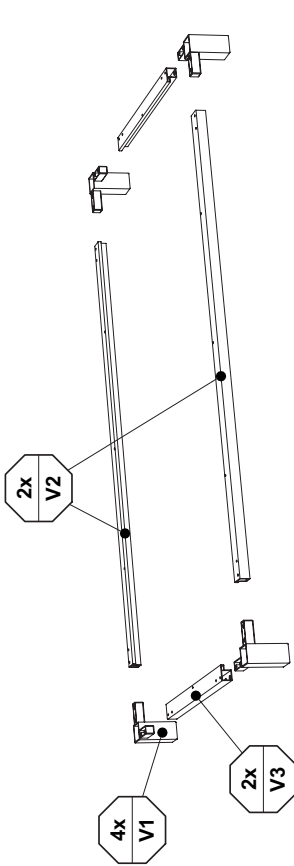

V1

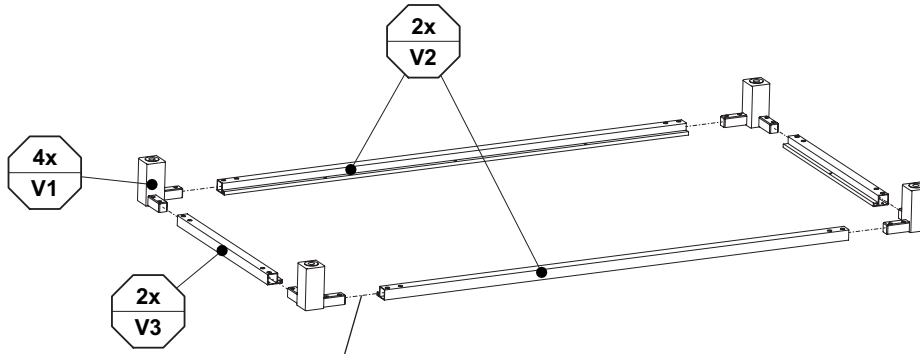

V1.1

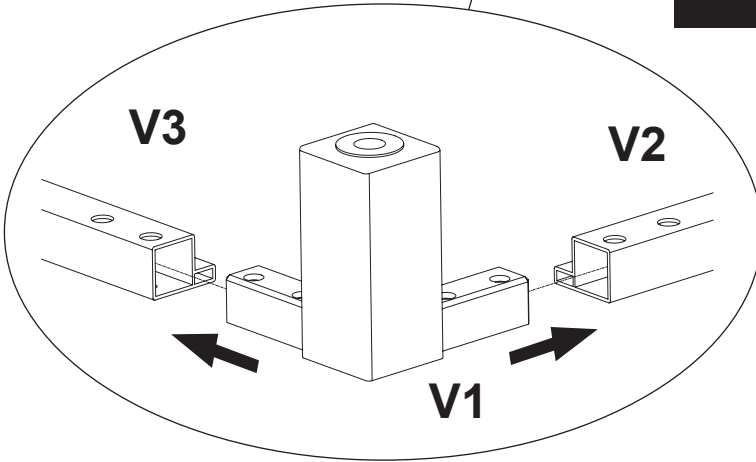

V1	V2	V3
	Sockelprofil	Sockelprofil
	Länge: 1141mm	Länge: 449mm
4x 681 8701	2x 681 8706	2x 681 8717

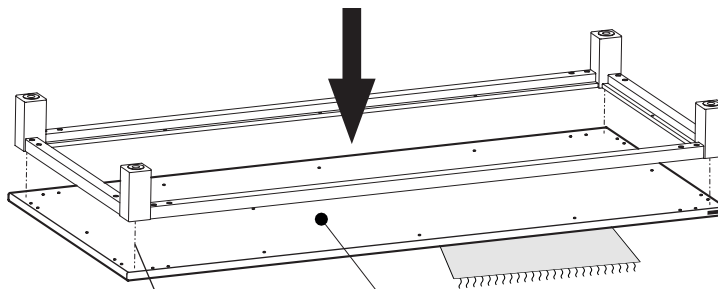

V1.2

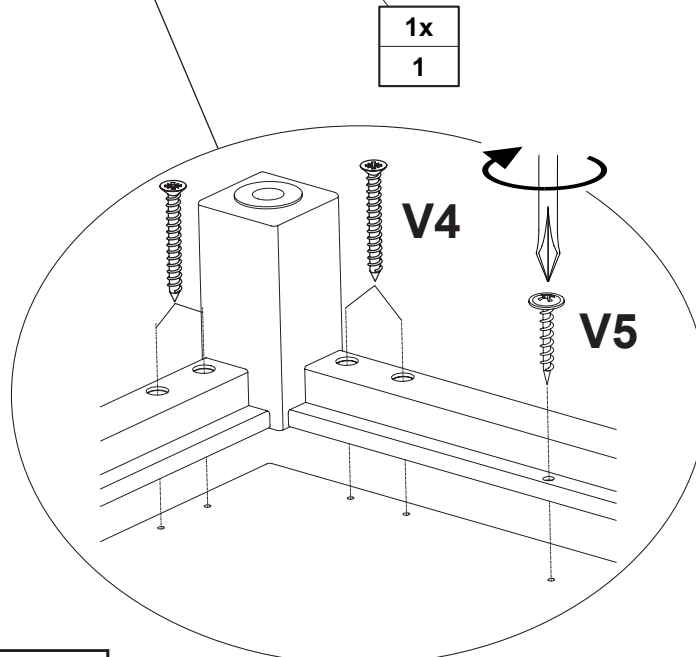

V4	V5
4 x 35 16x 681 5001	4,0 x 20 8x 681 4917



Height adjustment !
 Réglage de la hauteur !
 Hoogteverstelling !
 Регулировка высоты !
 高度调整!

Höhenverstellung !!

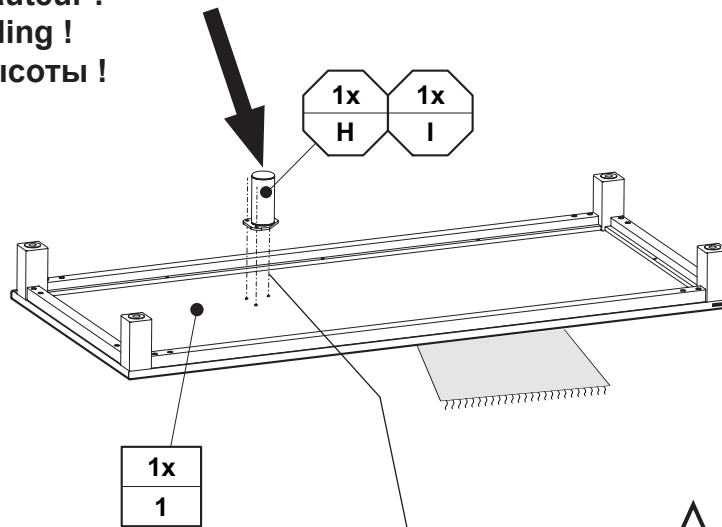

V1.3

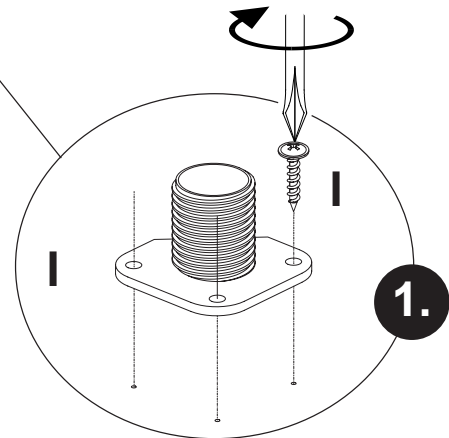
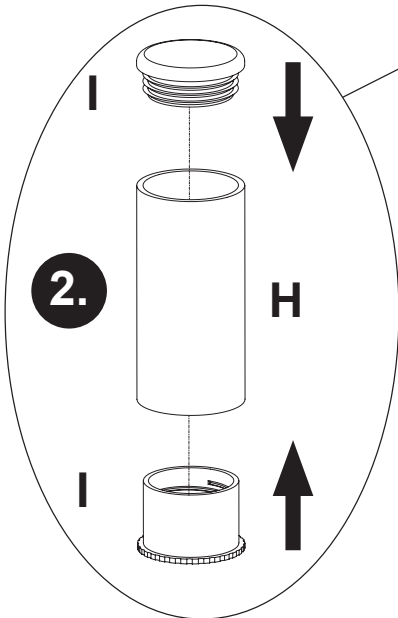
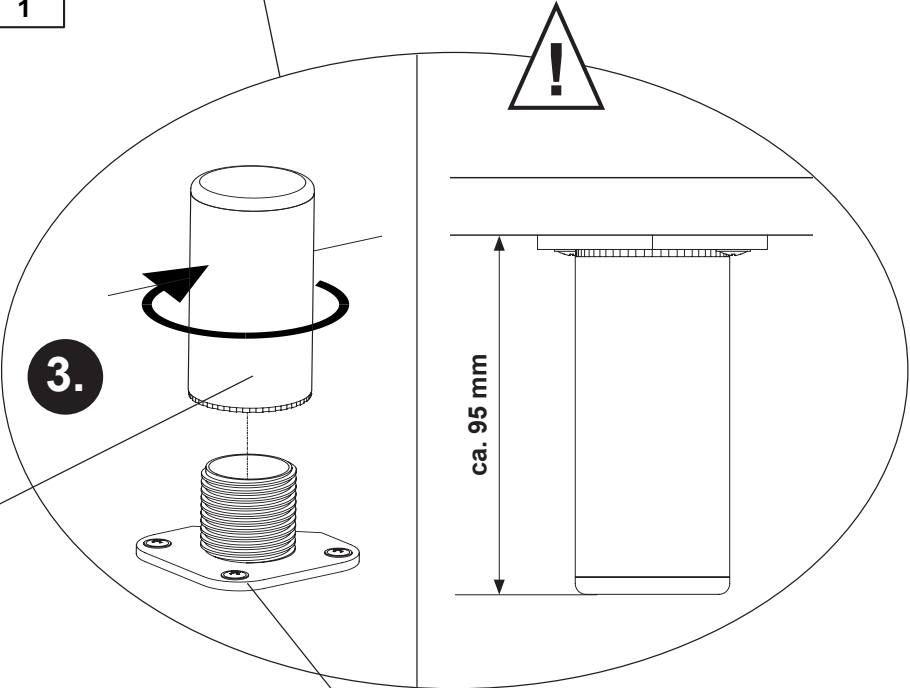

H		I				
	1x		1x	1x	1x	3x
	681 8405		681 8406	1x		4,0 x 17

V1



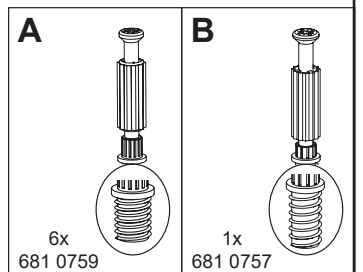
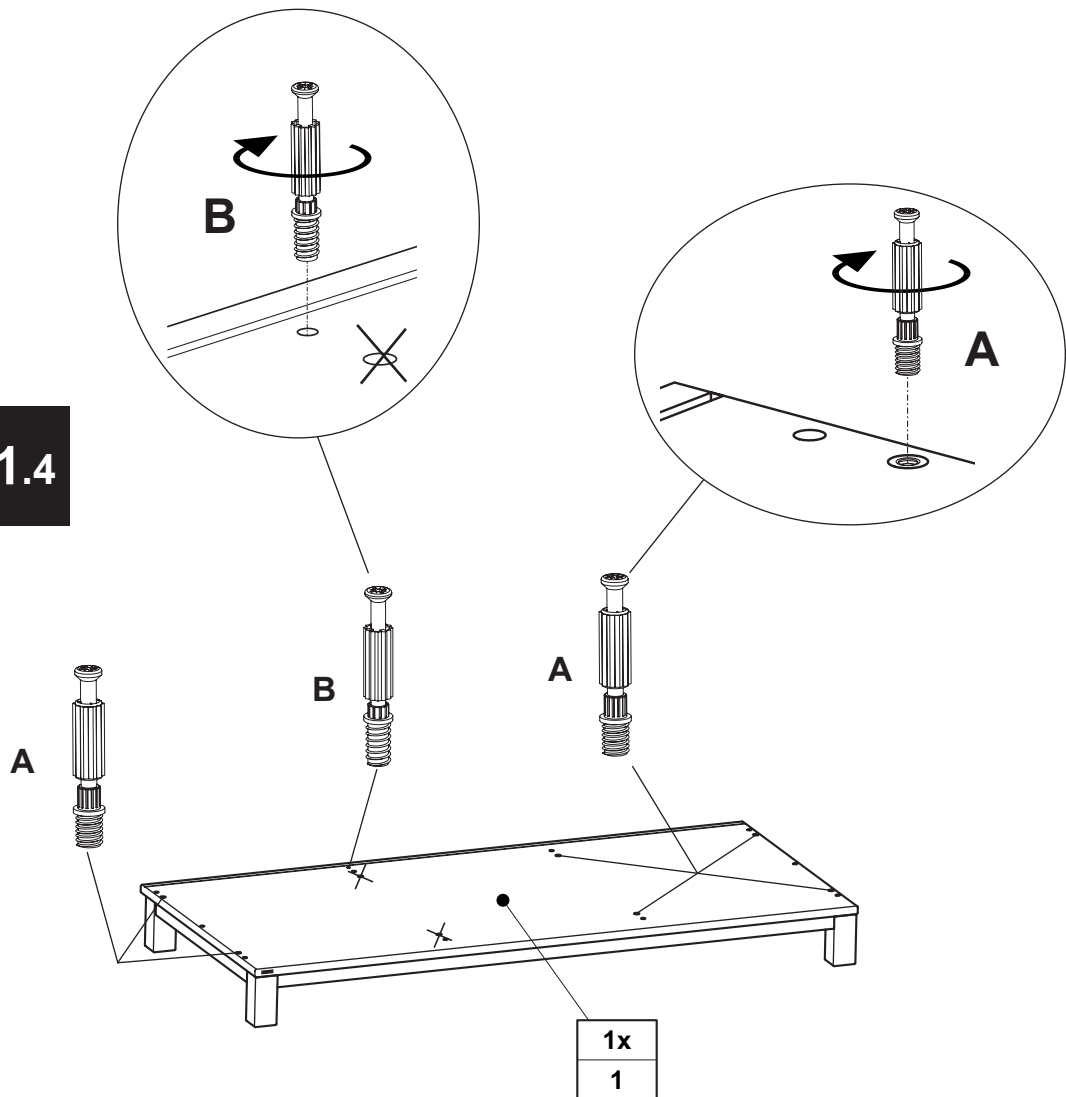

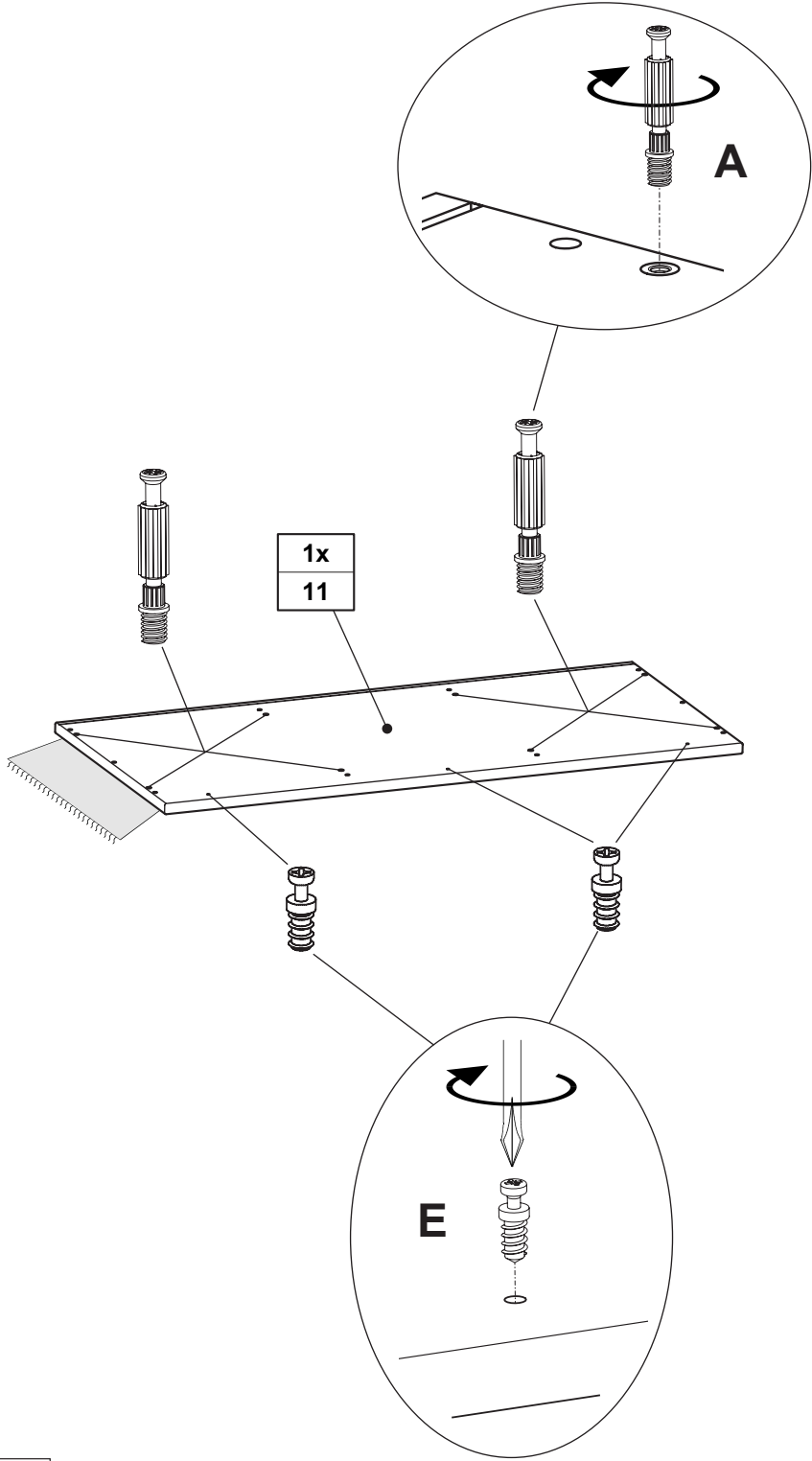
V1.4



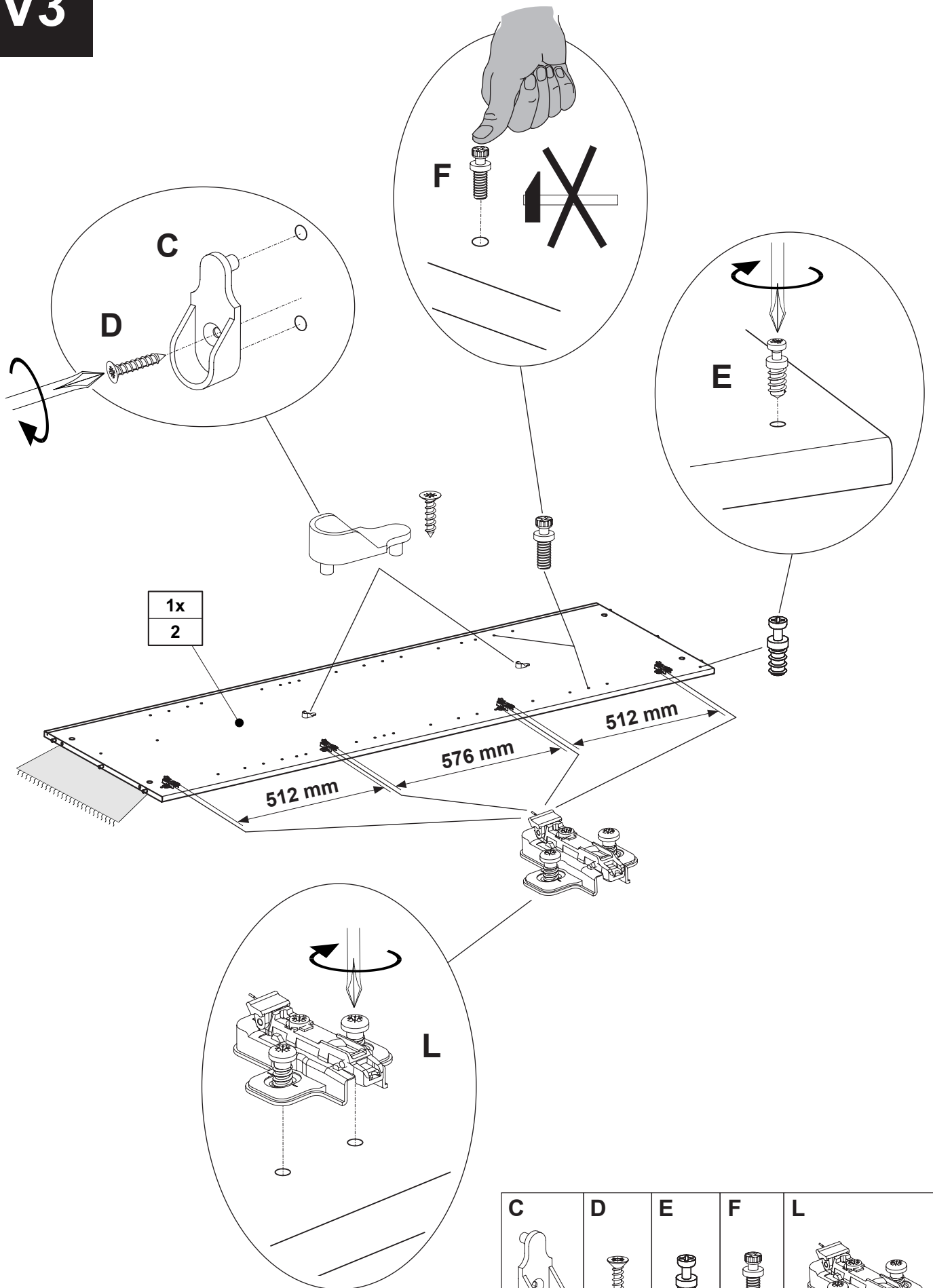

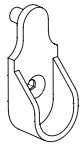

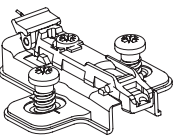

A		E	
8x		3x	
681 0759		681 0760	

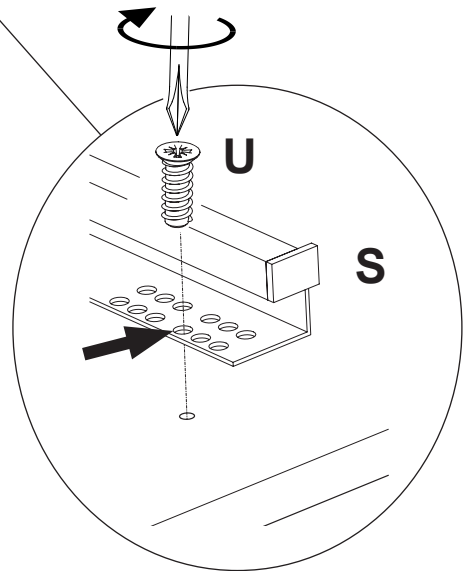
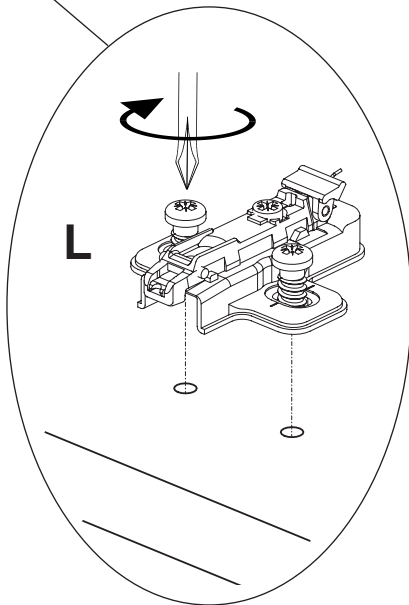
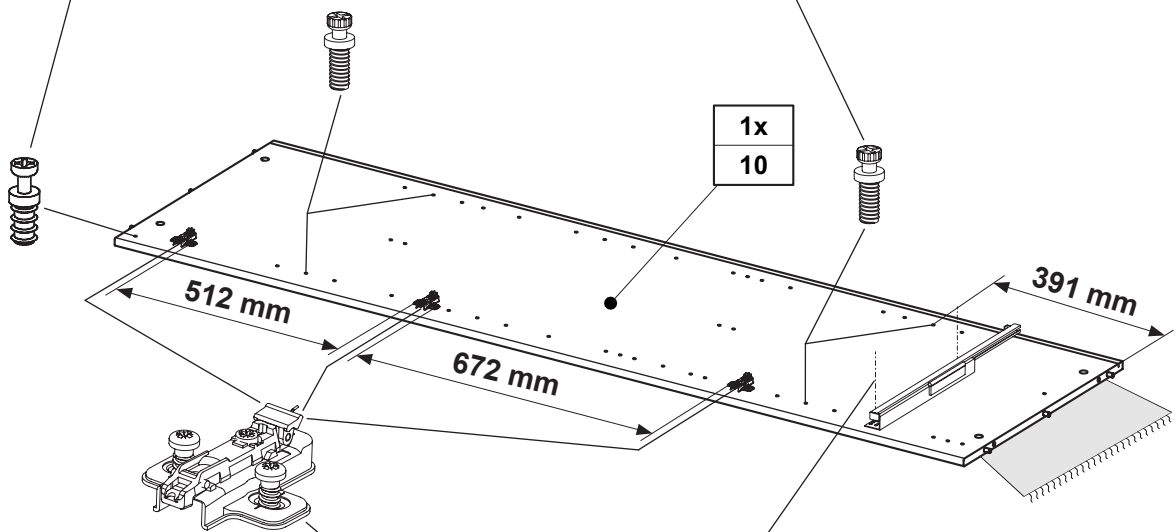
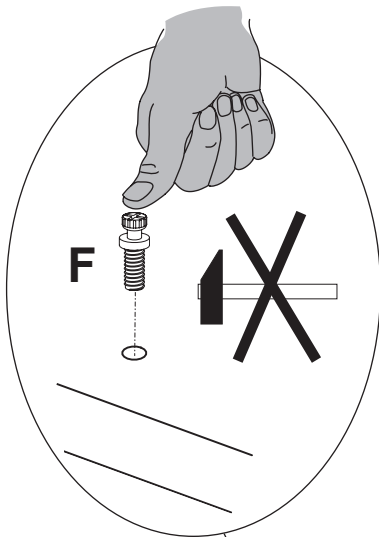
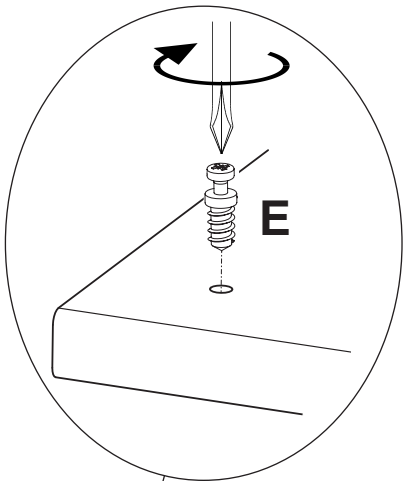

C	D	E	F	L
				
2x 681 1645	3,5 x 13 2x 681 4887	1x 681 0760	2x 681 8126	4x 681 2888

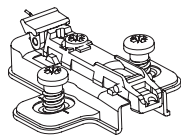
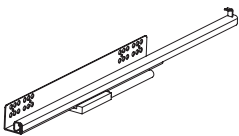



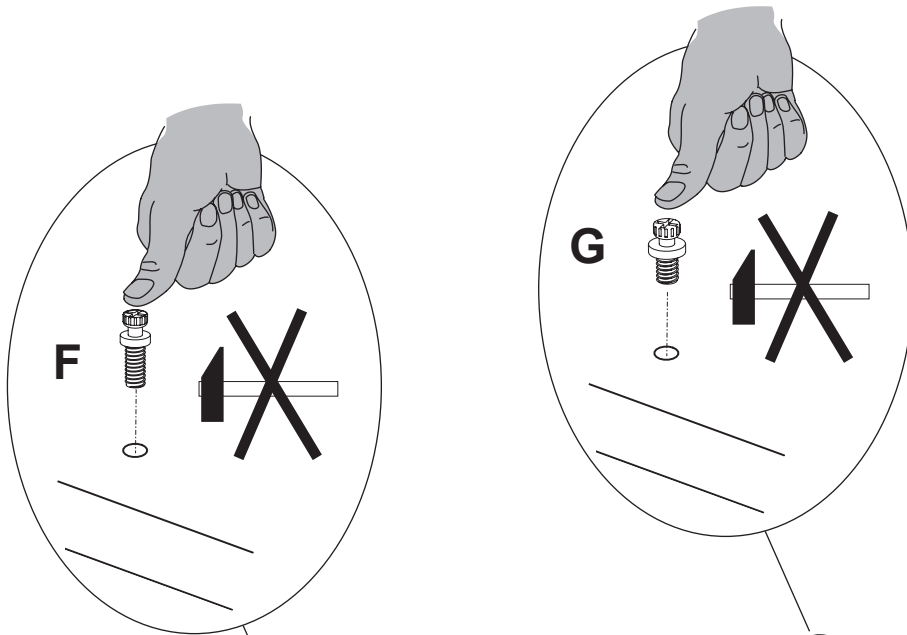

<p>E</p>  <p>1x 681 0760</p>	<p>F</p>  <p>4x 681 8126</p>	<p>L</p>  <p>3x 681 2888</p>	<p>S</p>  <p>1x 681 3314</p>	<p>U</p>  <p>6,3 x 14 2x 681 5097</p>
--	--	--	--	---

V5

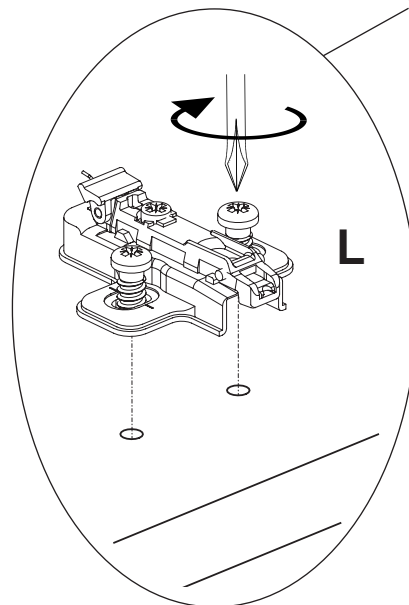
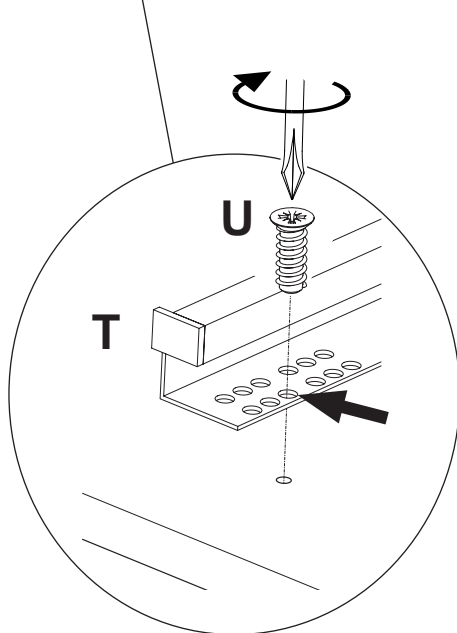
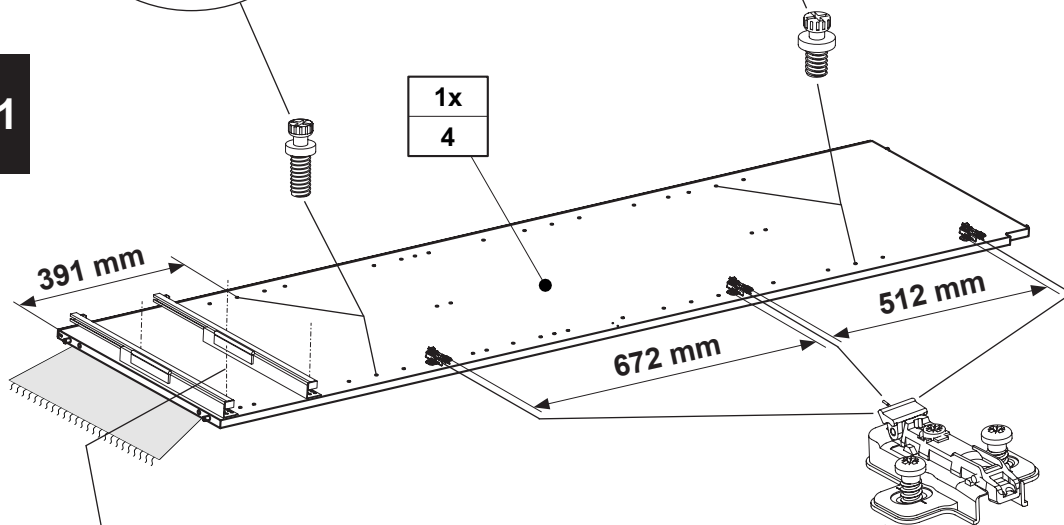

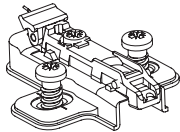
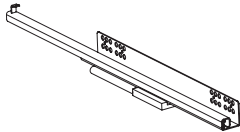

V5.1

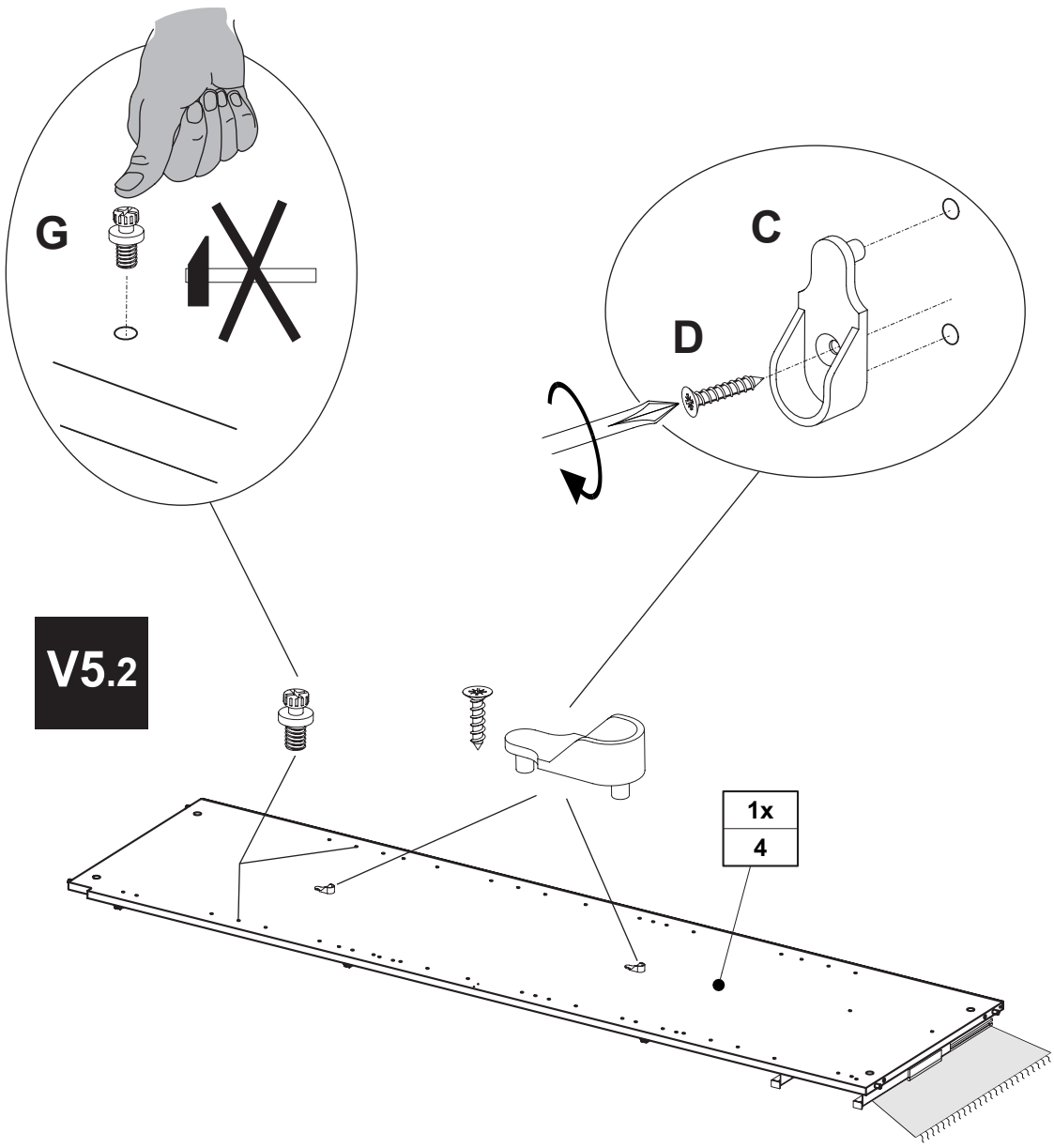

F	G	L	T	U
				
2x 681 8126	2x 681 8137	3x 681 2888	2x 681 3315	6,3 x 14 4x 681 5097



V5.2

G	C	D
		
2x 681 8137	2x 681 1645	3,5 x 13 2x 681 4887

V6

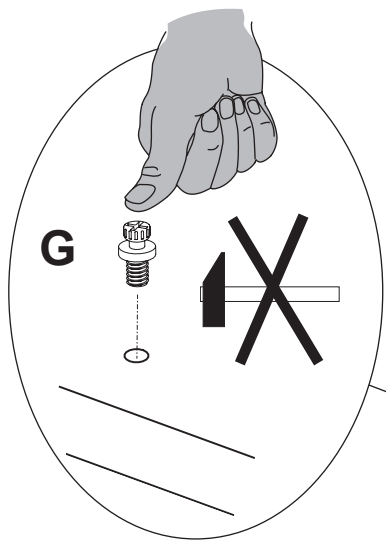

V6.1

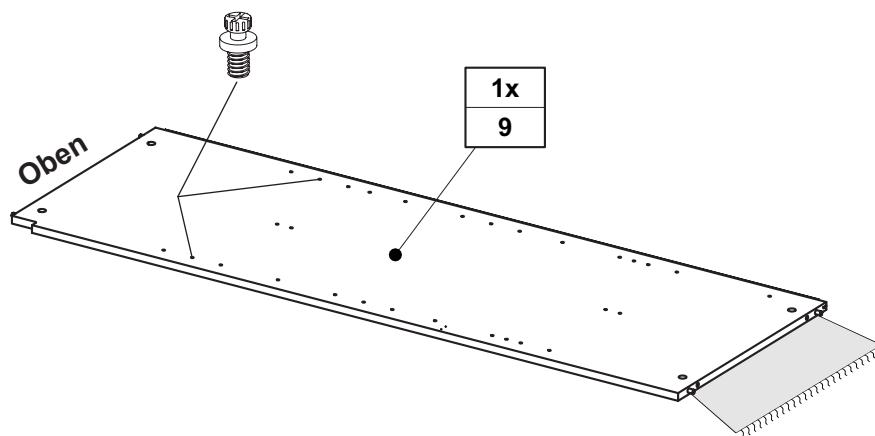
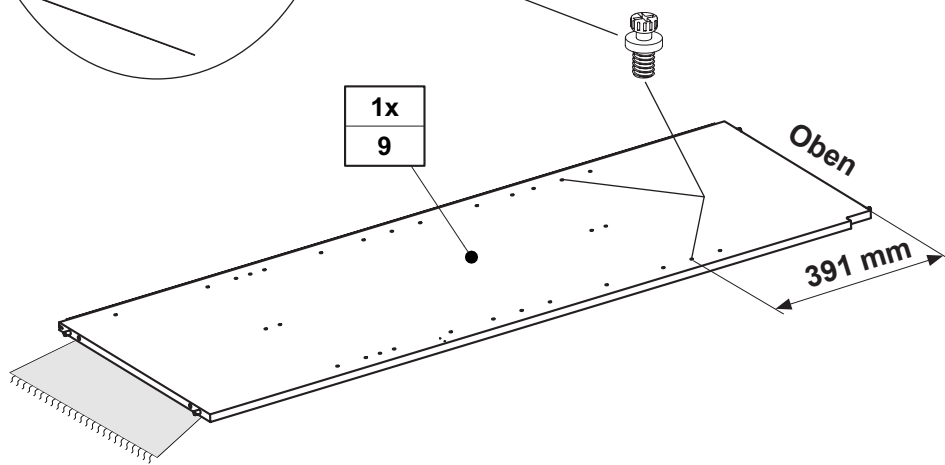

V6.2

G



4x
681 8137

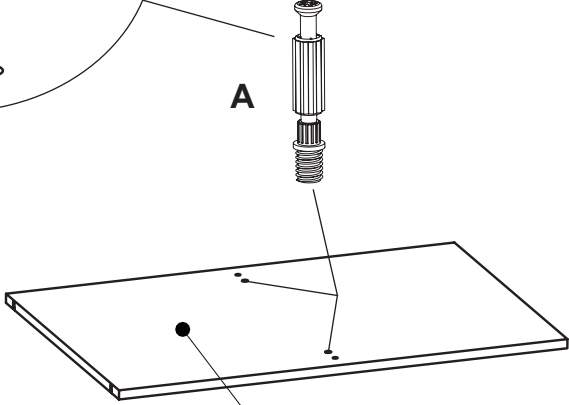
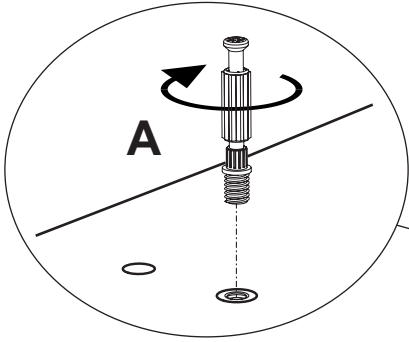

V7.1

1x
8

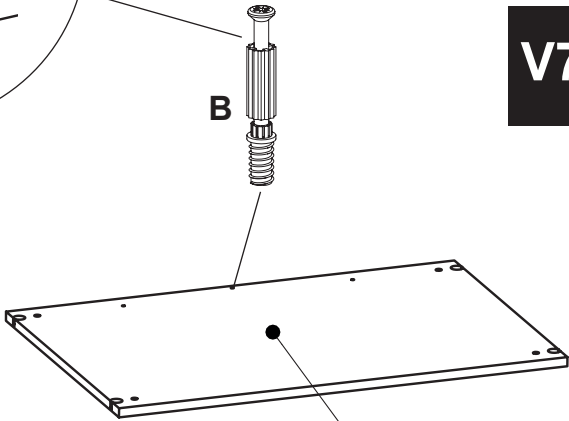
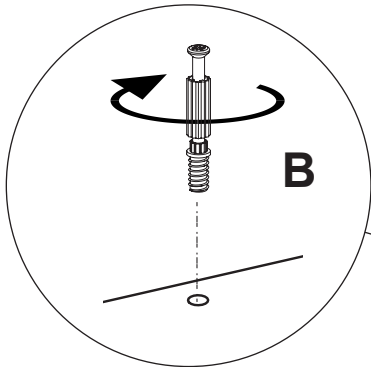

V7.2

1x
8

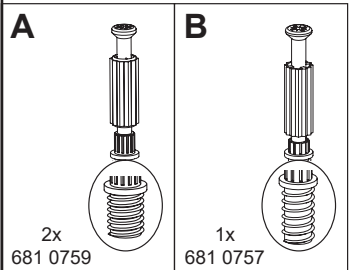

V8

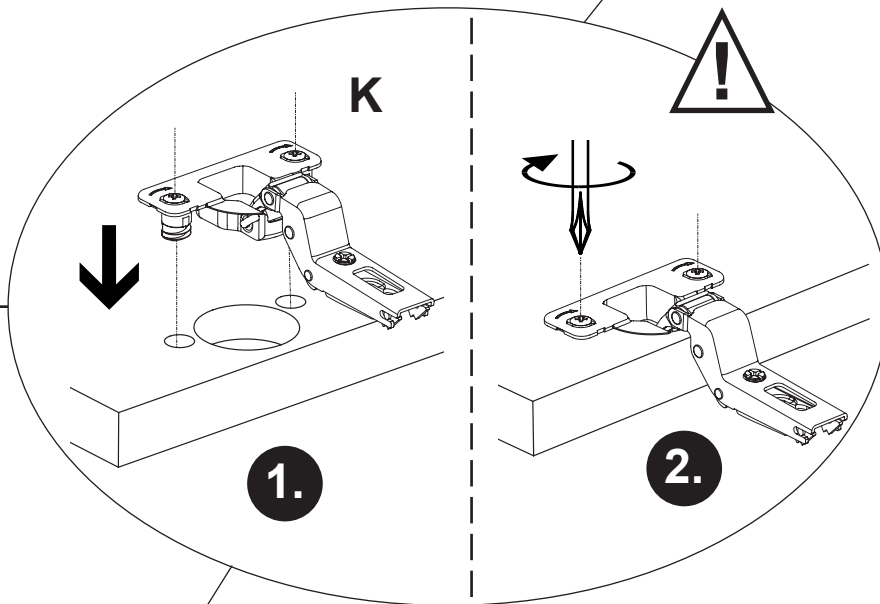
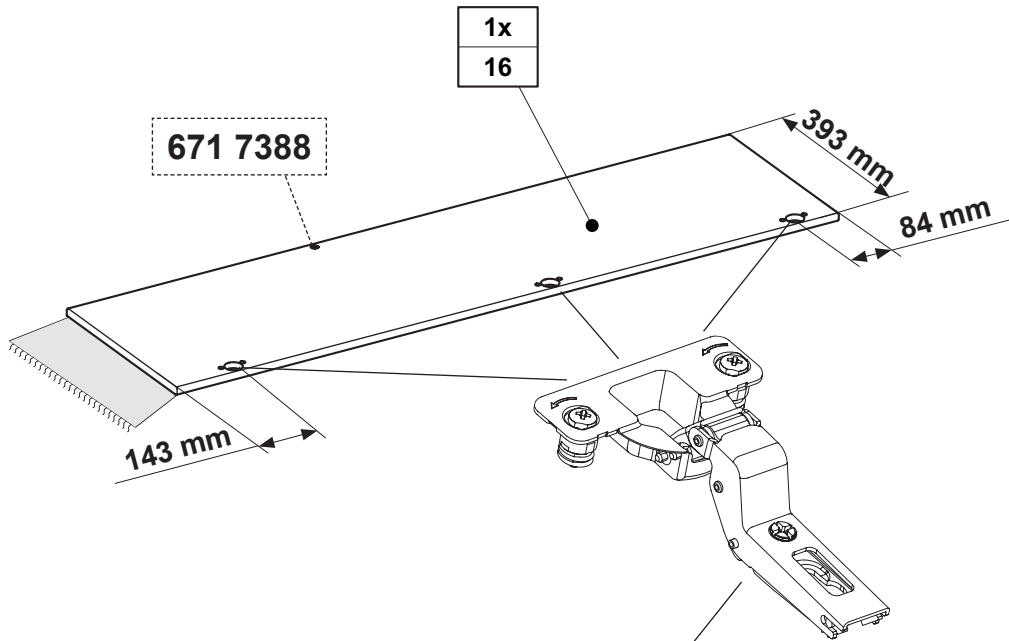

V9

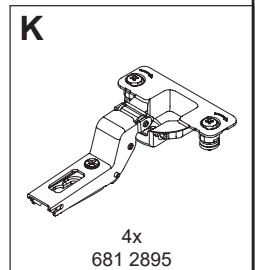
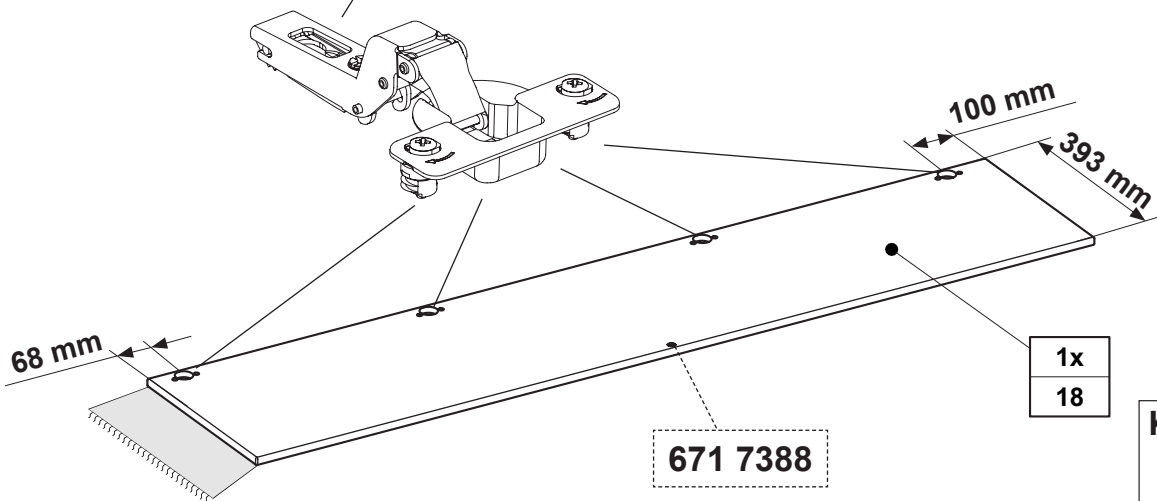

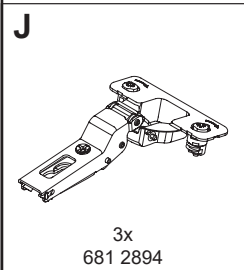
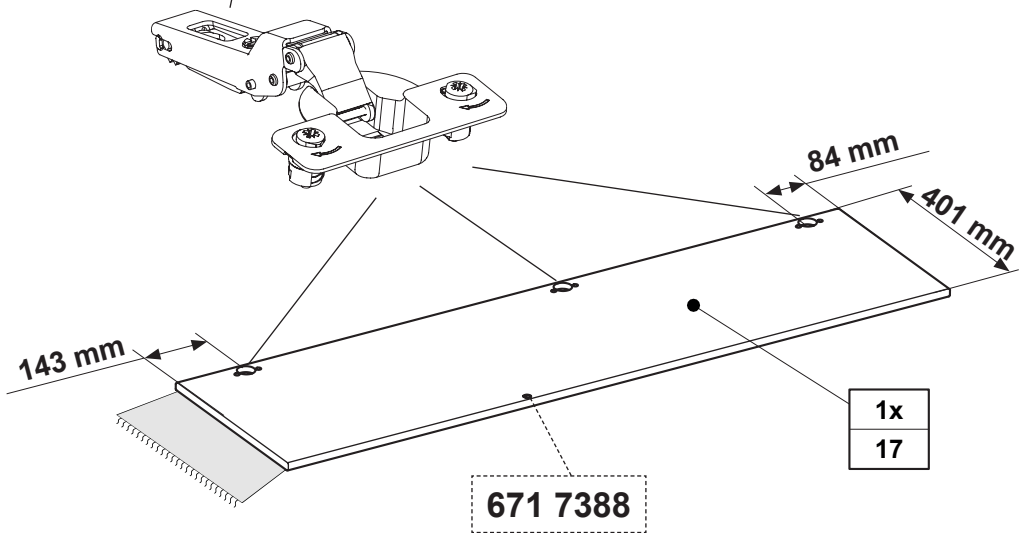
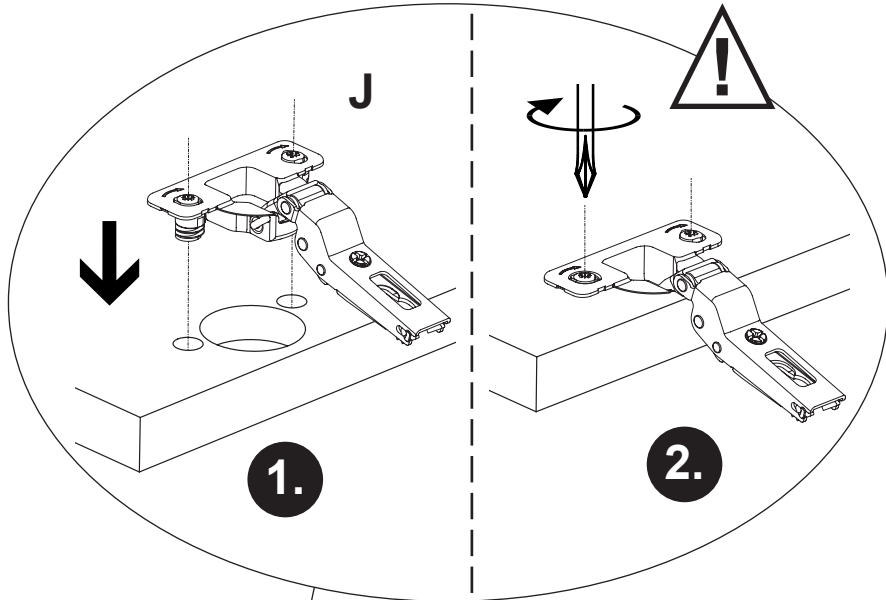

M1

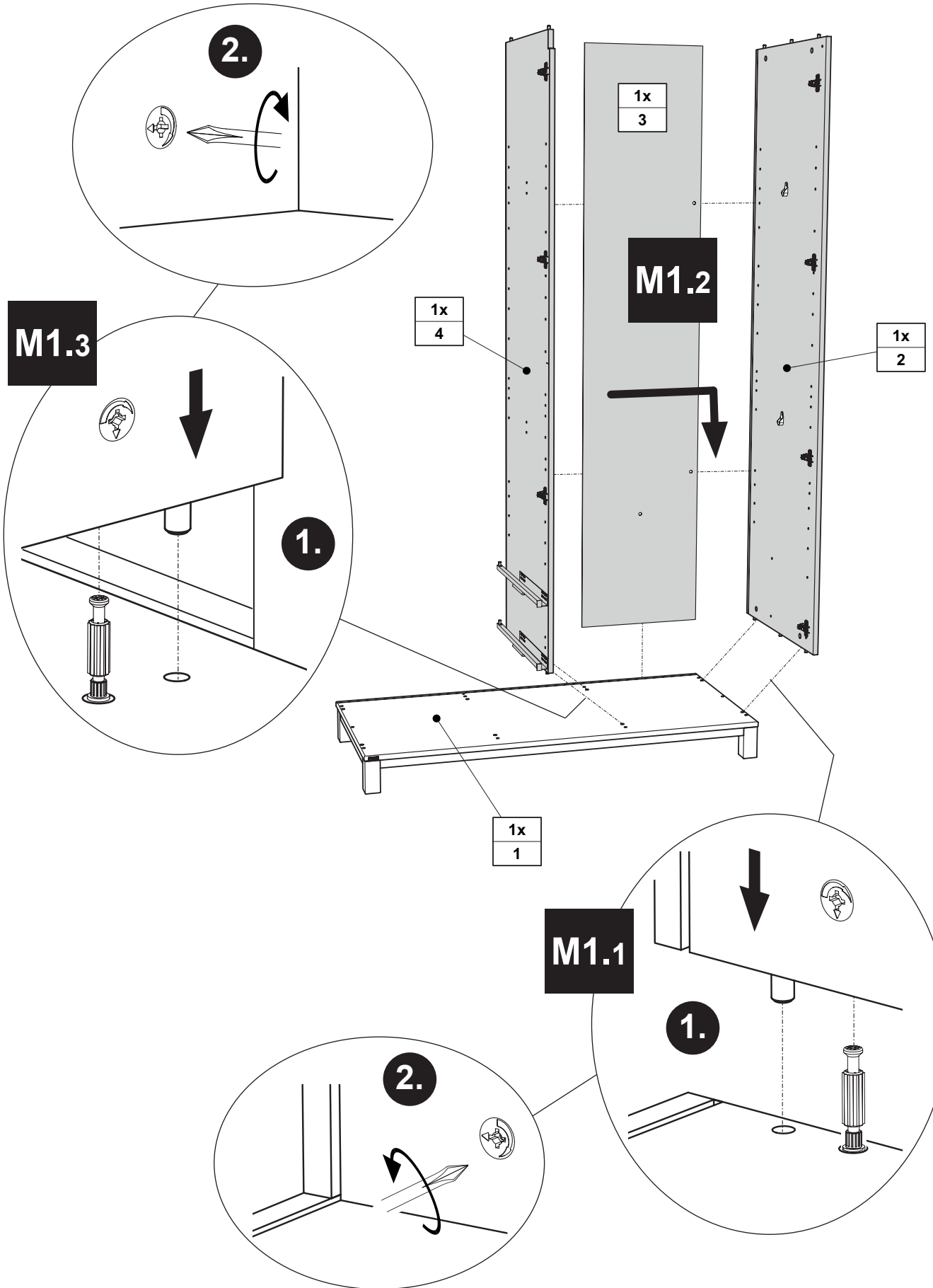

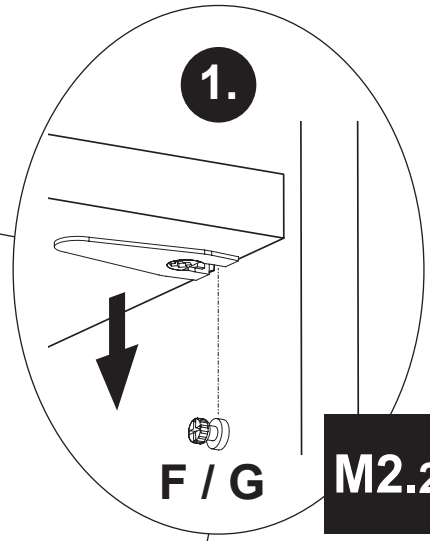
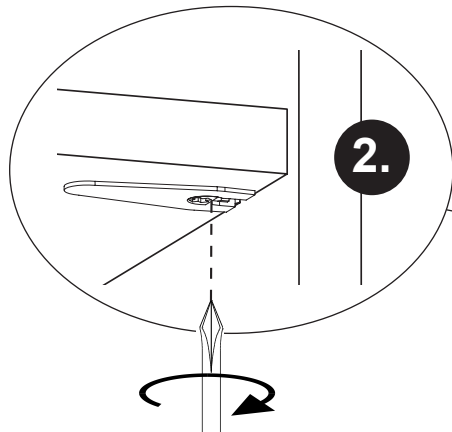

F / G

M2.2

M2.1

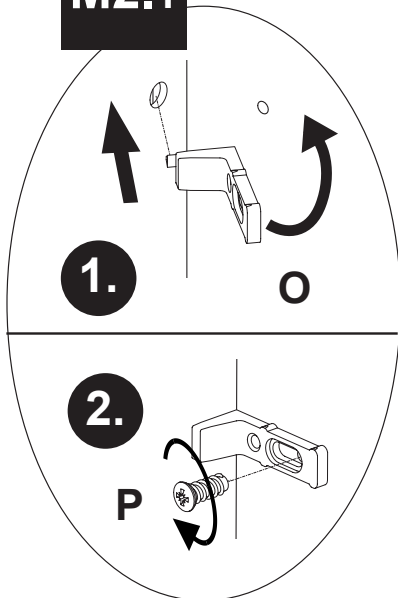

1.

O



2.

P

1x
5

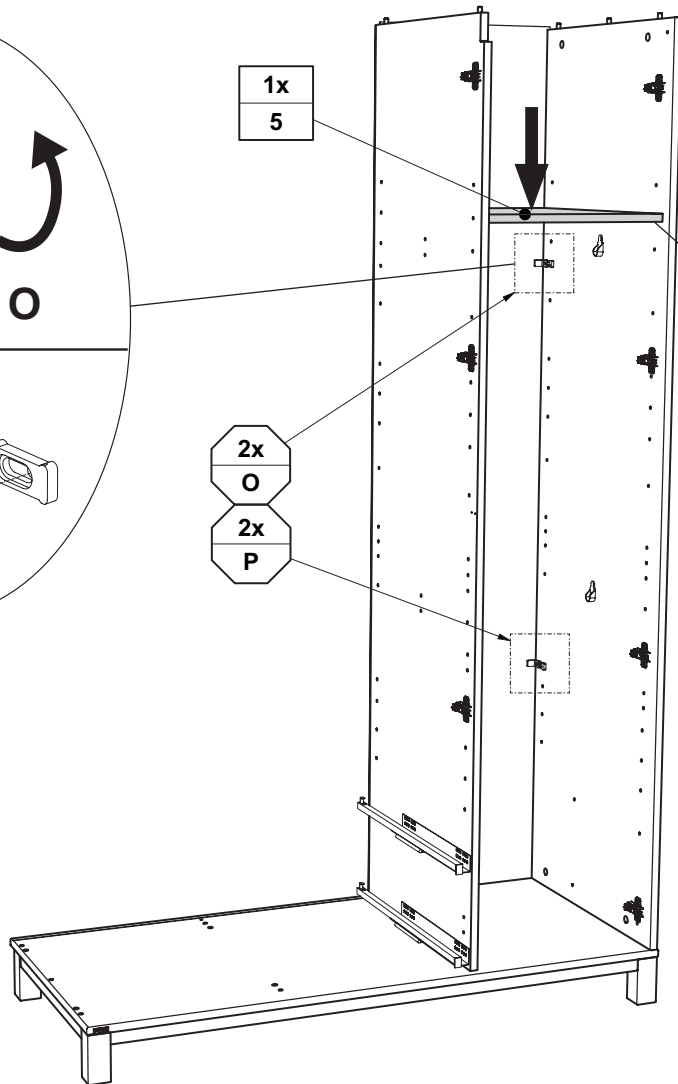
2x
O
2x
P

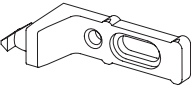

O	P
	
2x 681 2497	6,3 x 15 2x 681 5060

M3

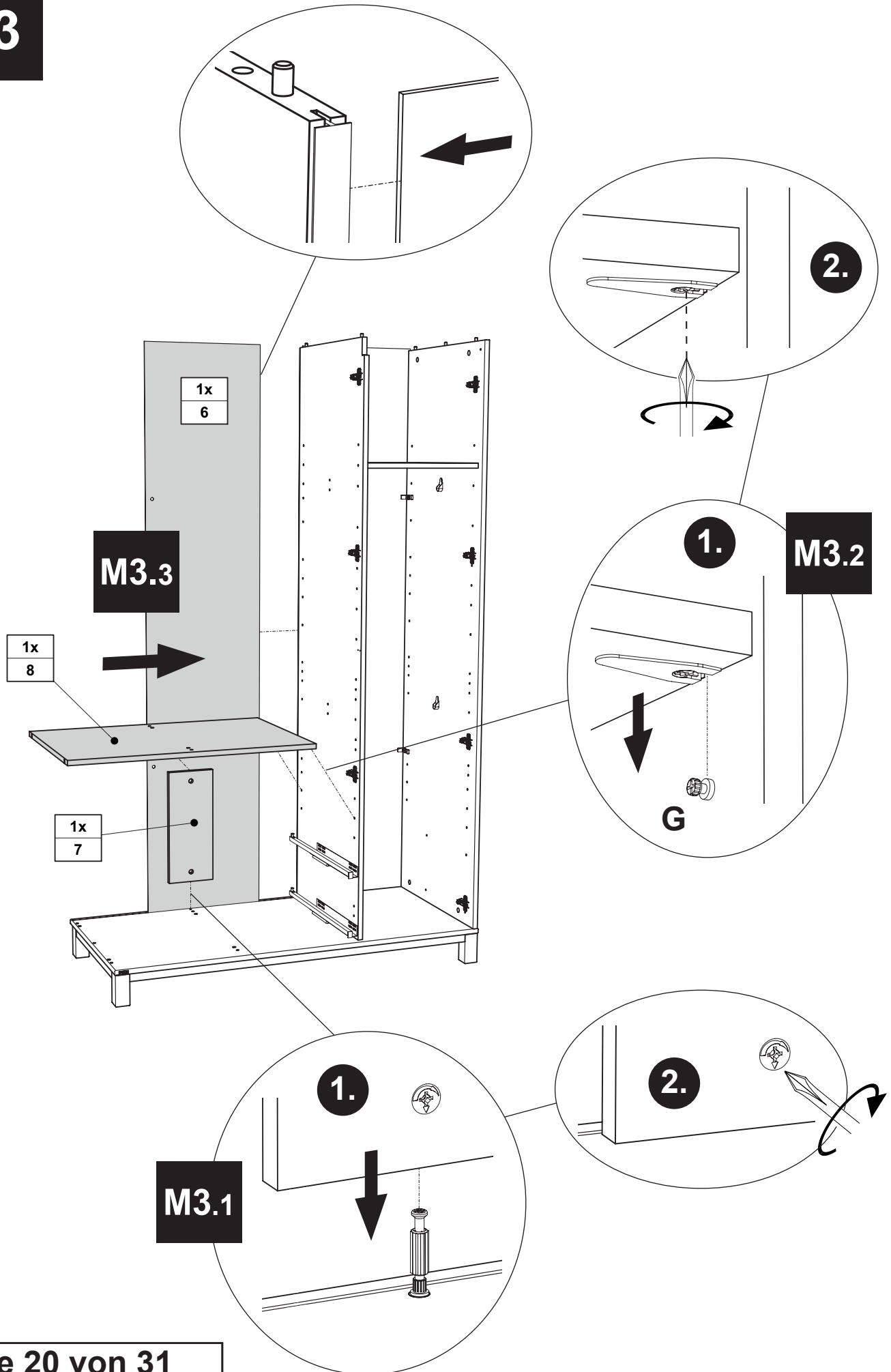

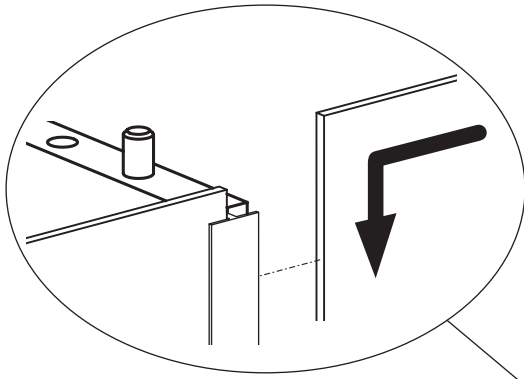

1x
9

1x
6

M4.2

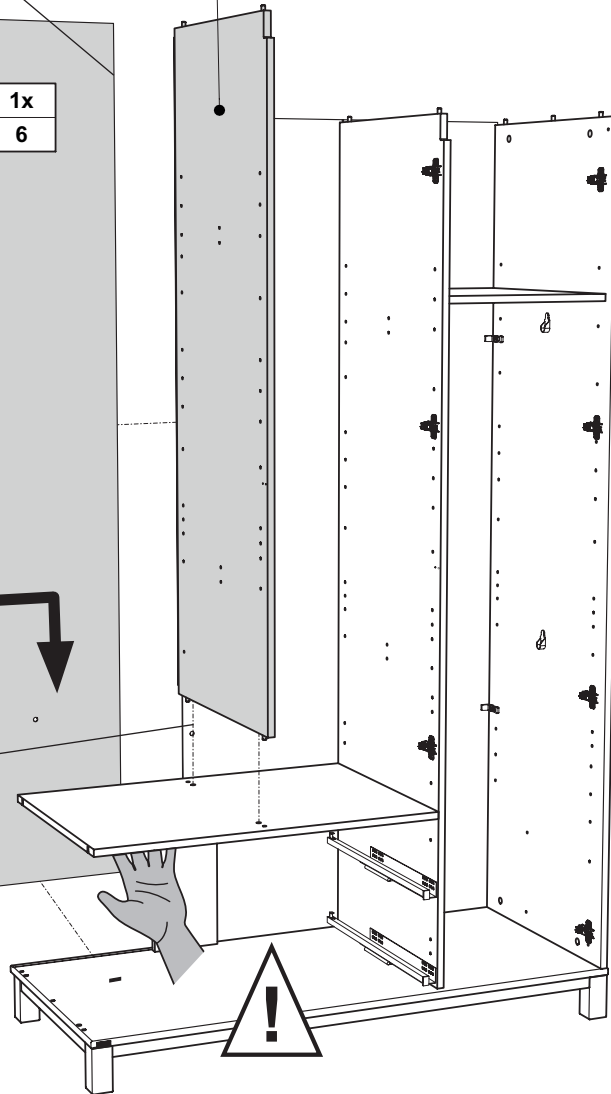

M4.1

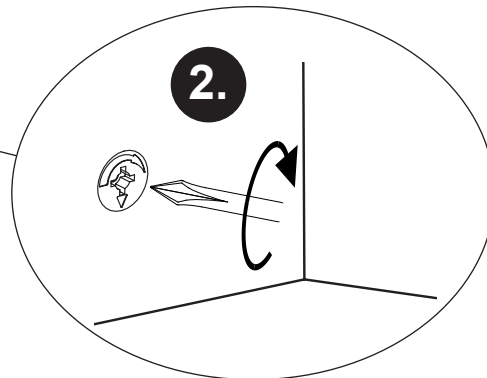
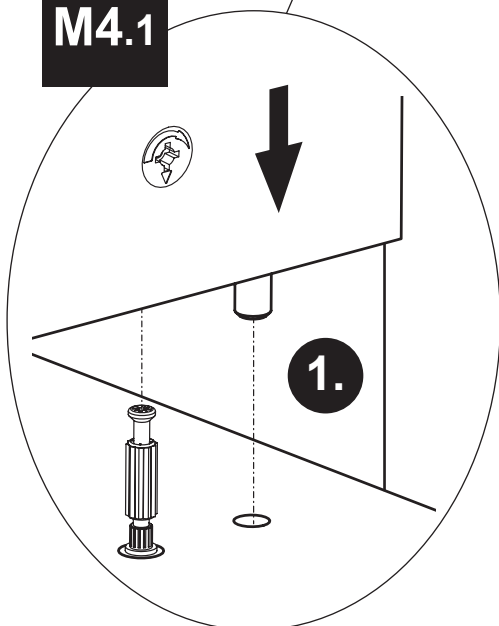

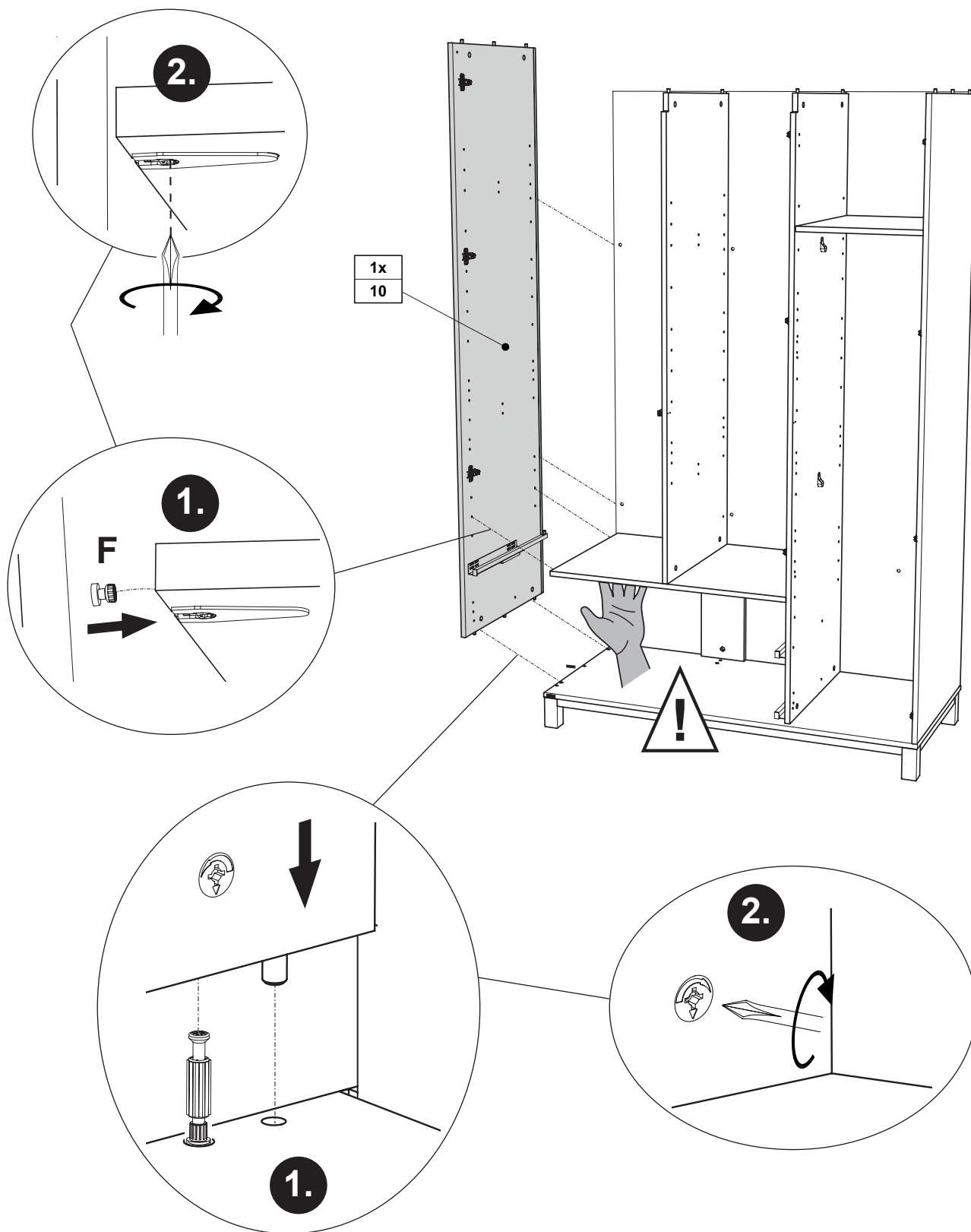

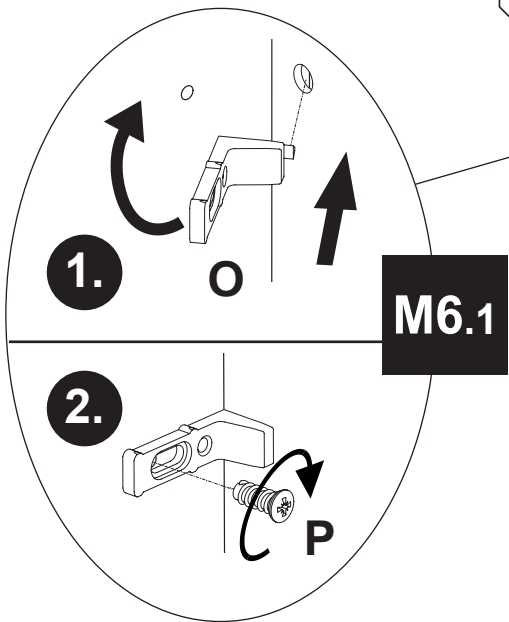
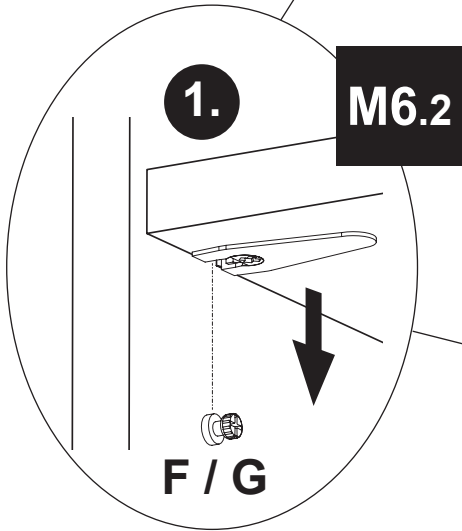
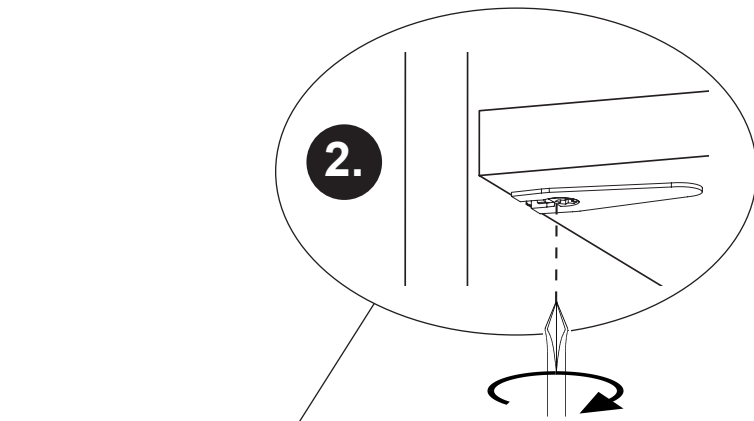



2x
5

4x
O
4x
P

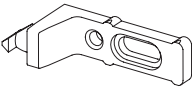
1x
Y

O	P	Y
		
4x 681 2497	6,3 x 15 4x 681 5060	Weiss white ø10 x 15 1x 683 0051

M7

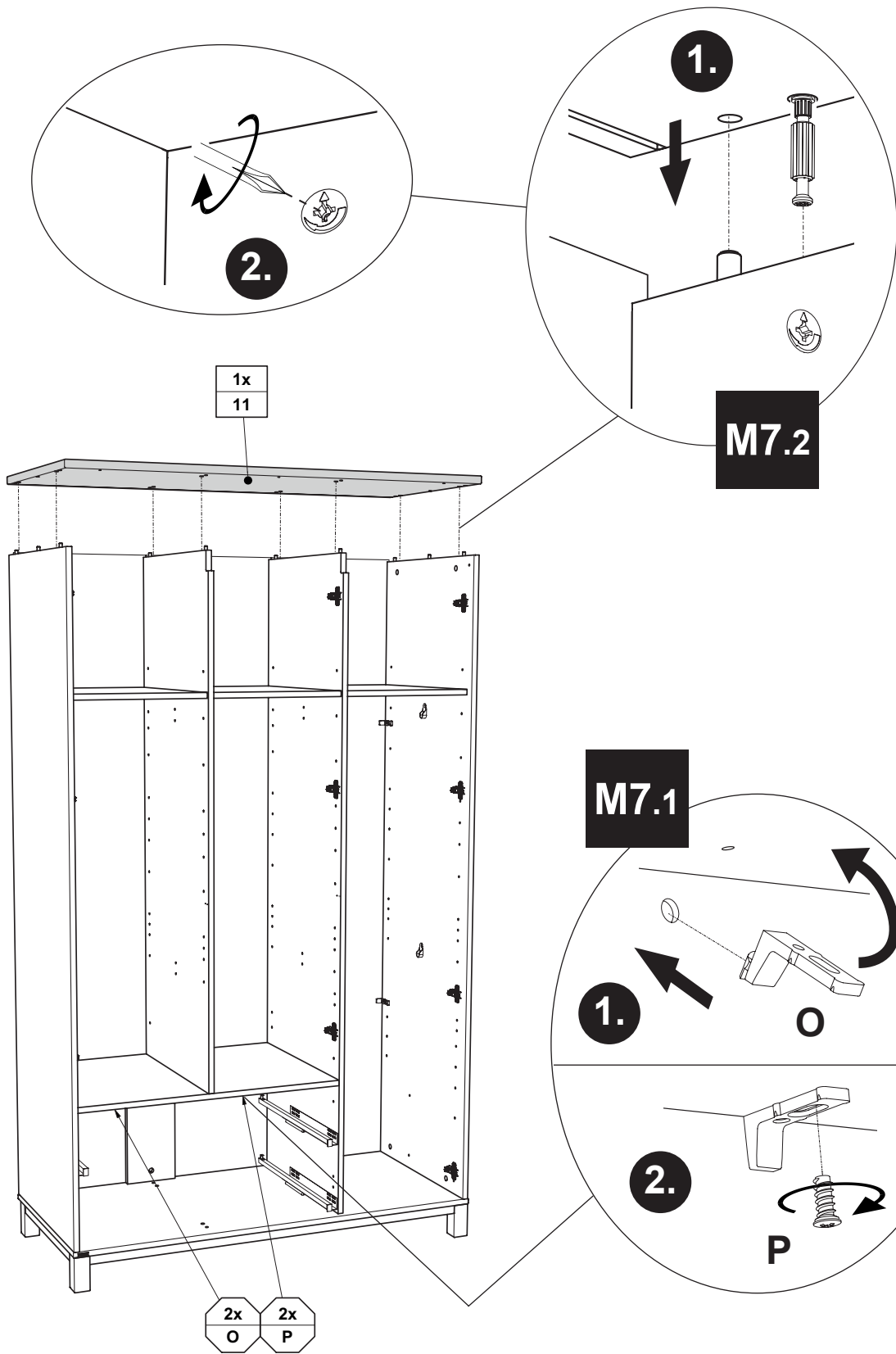



1x
11

M7.2

M7.1

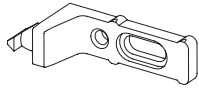
2x O 2x P

O	P
	
2x 681 2497	6,3 x 15 2x 681 5060

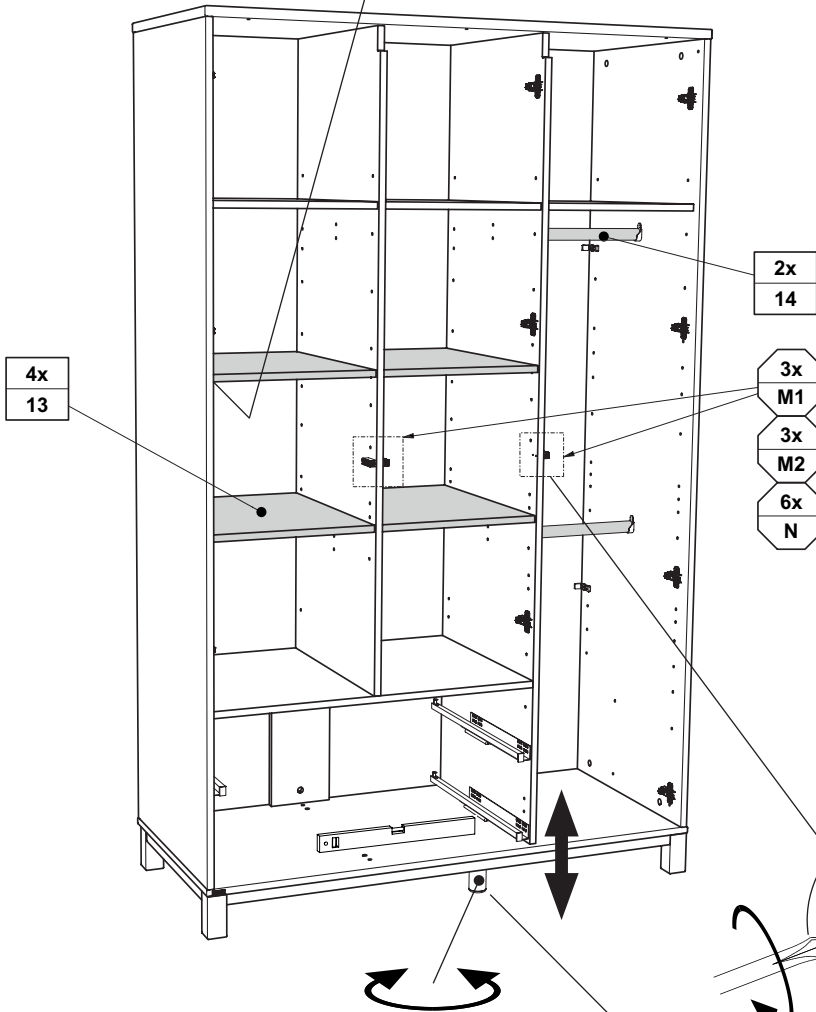
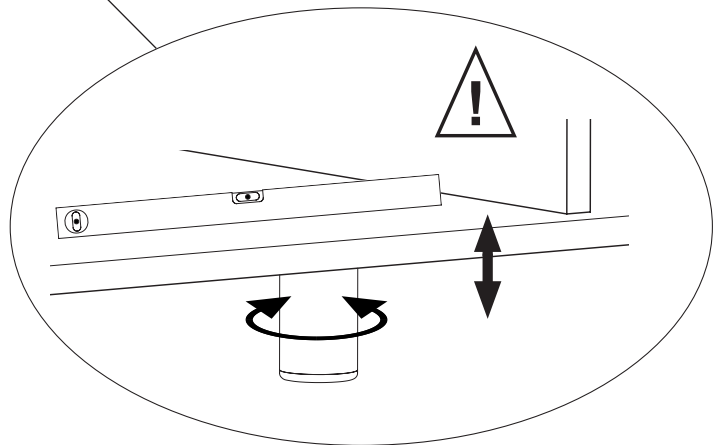
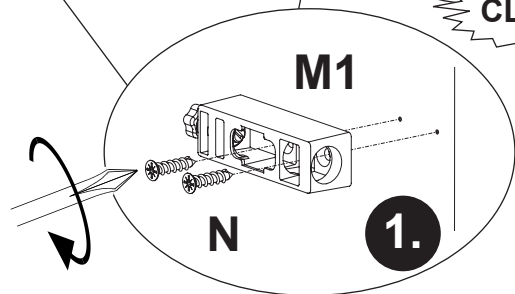
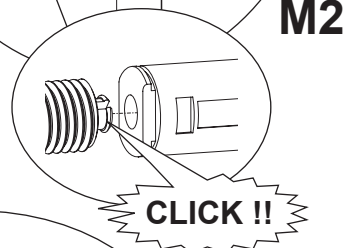
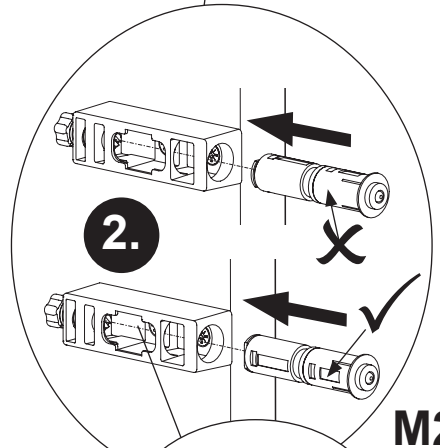
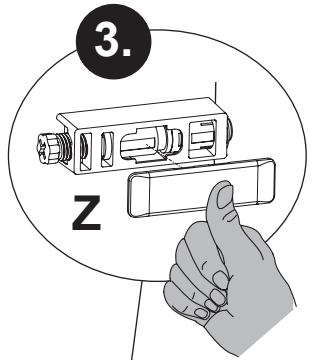
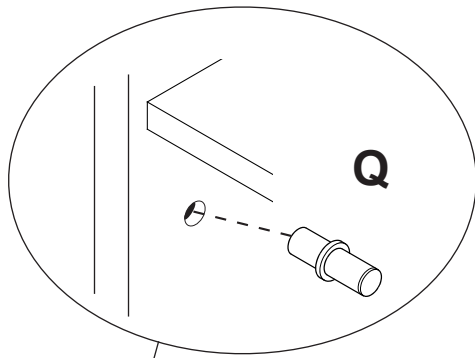

Q	Z
16x 681 0350	3x 681 2852

M1	M2	N
3x 681 7326	3x 681 8027	3,0 x 13 6x 681 4705

M9

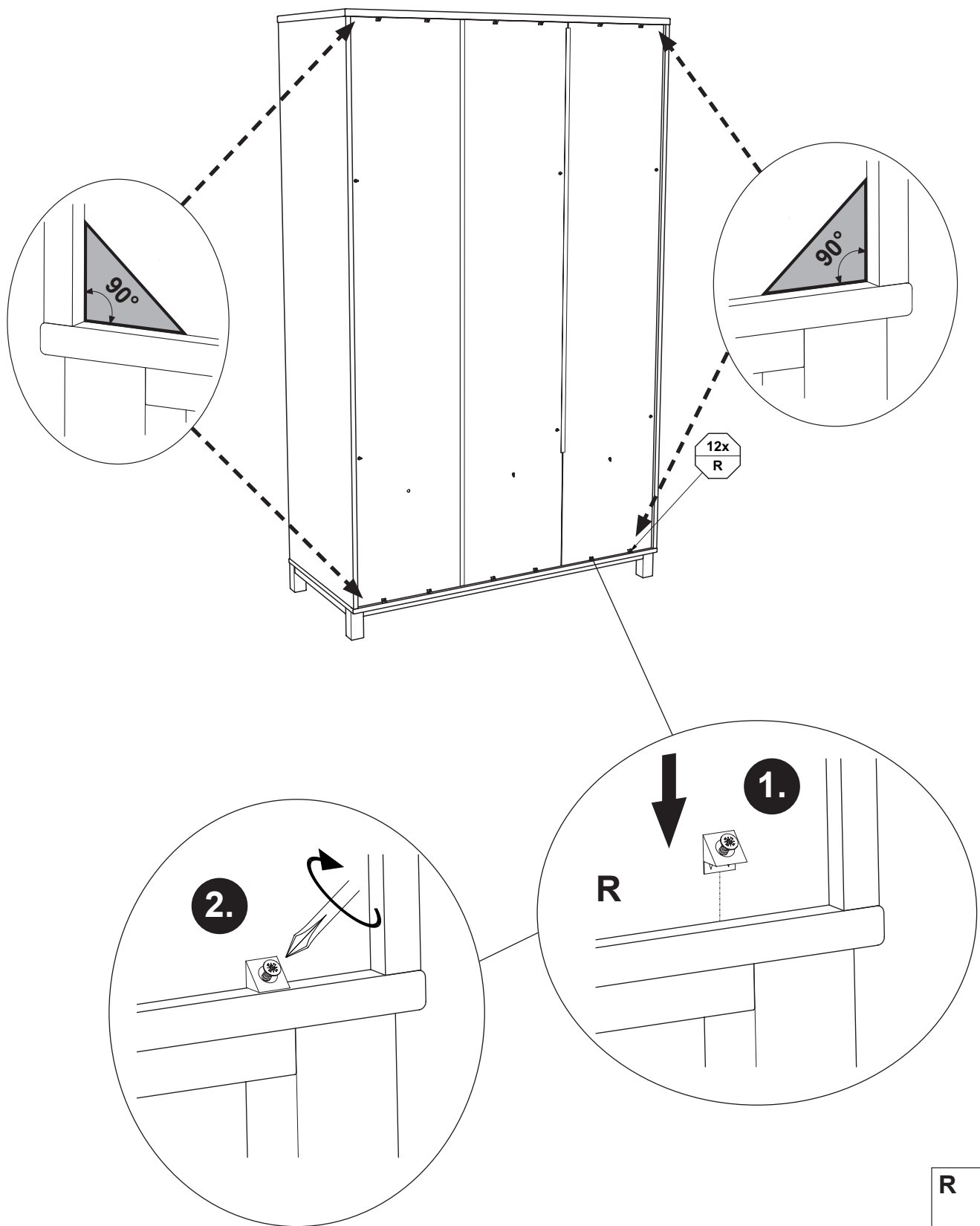

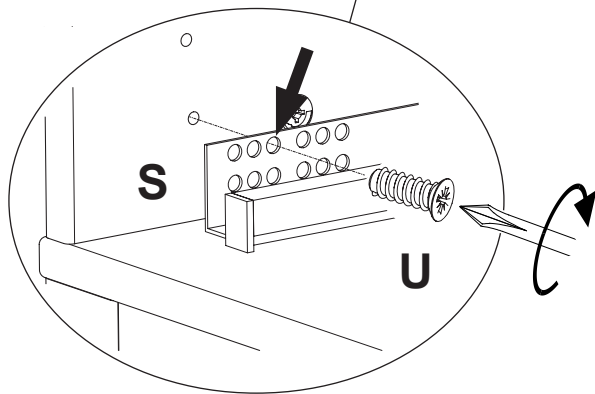
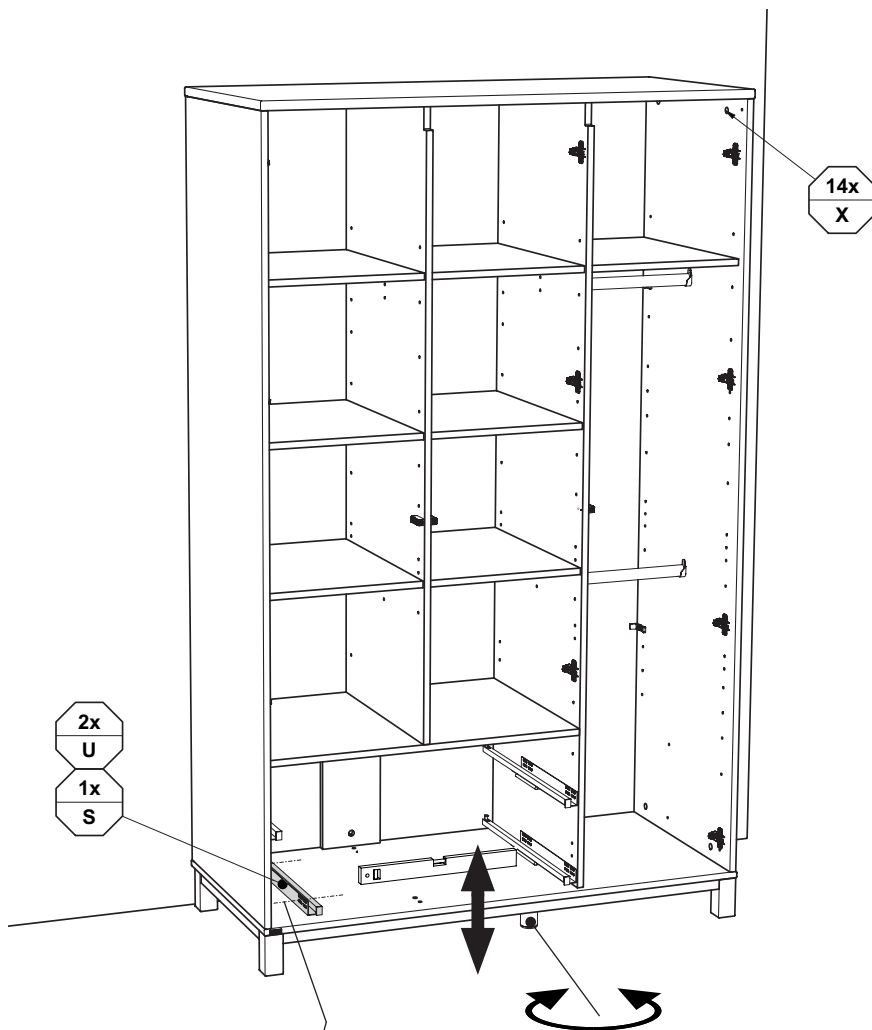

Höhenverstellung !



Height adjustment !

Réglage de la hauteur !

Hoogteverstelling !

Регулировка высоты !

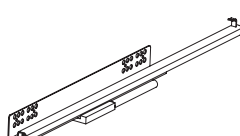
高度調整!

<p>S</p>  <p>1x 681 3314</p>	<p>U</p>  <p>6,3 x 14 2x 681 5097</p>	<p>X</p>  <p>Weiss white 14x 683 0101</p>
---	---	---

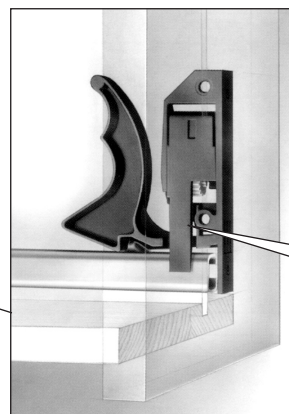
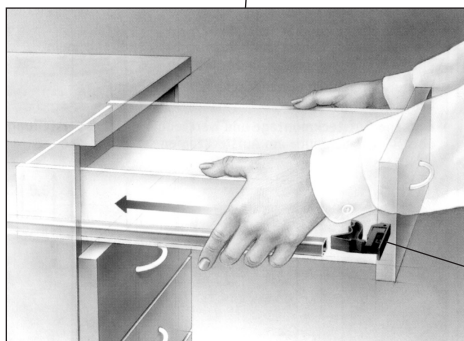
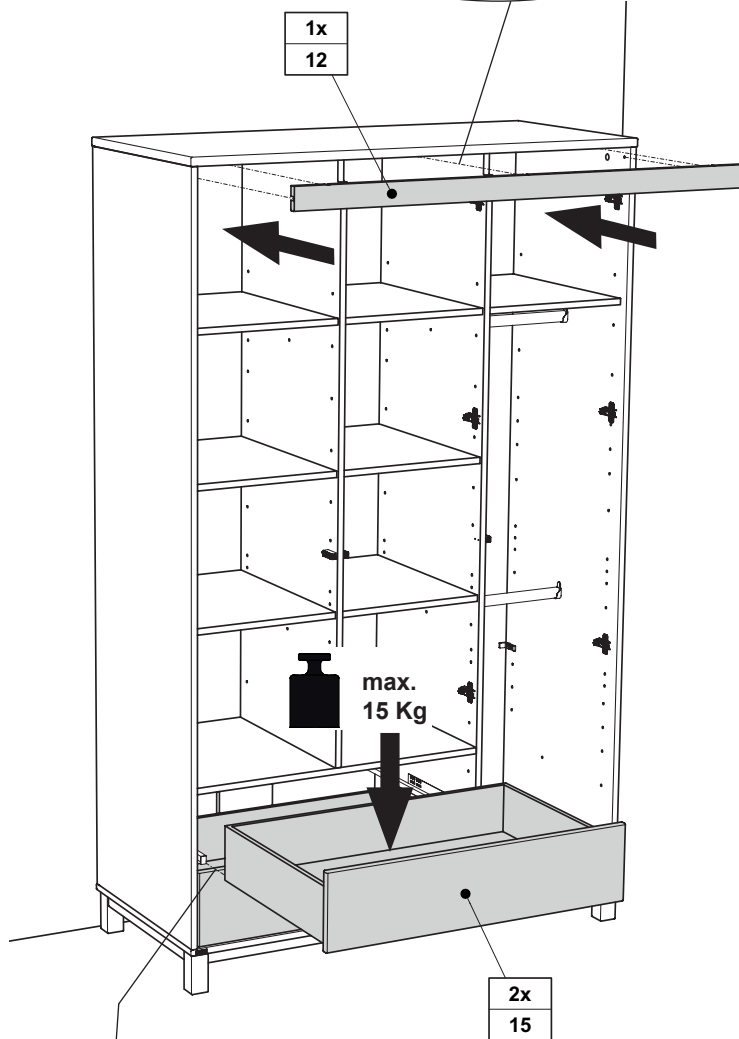
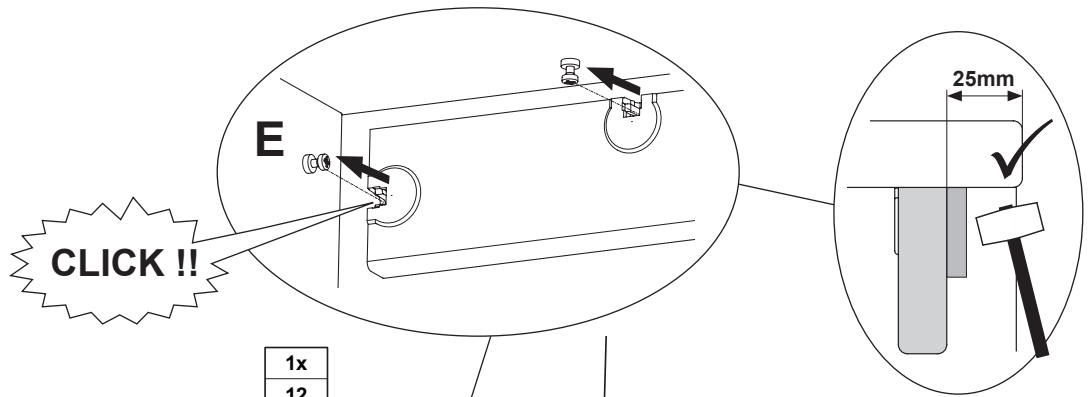

PK-Nr. 2800

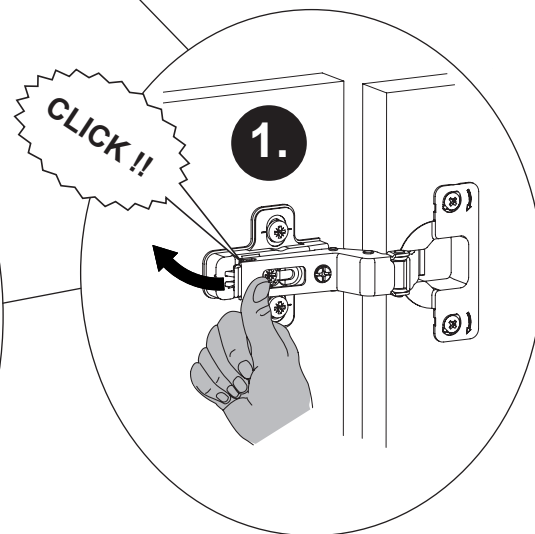
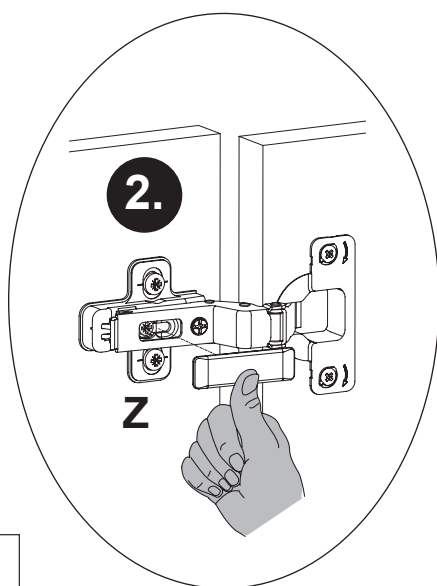
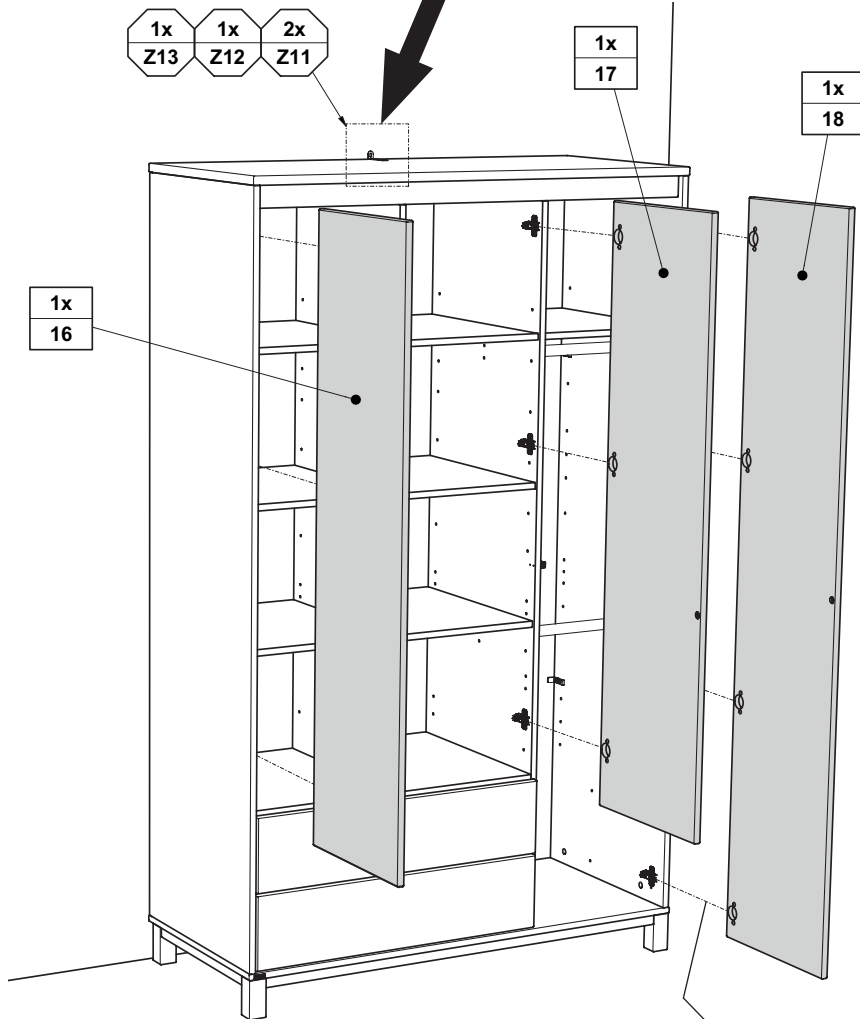

Z



10x
681 2852

„Push to open“ Justierung
„Push to open“ Adjustement / „Push to open“ Ré-
glage / „Push to open“ Afstelling / „Push to open“
Регулировка / „Push to open“ 调整

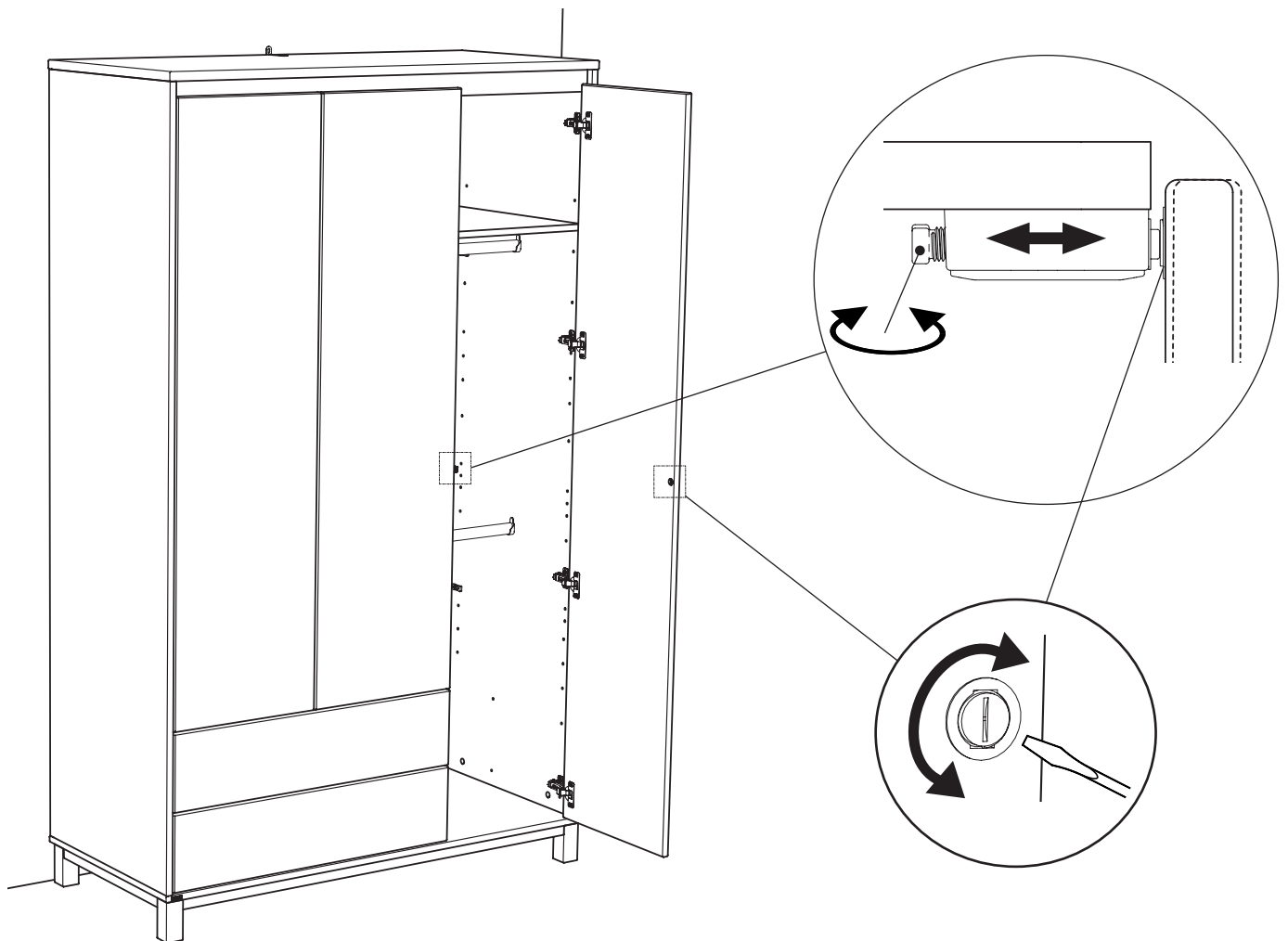

Demontage der Schubkästen

Disassembly of the drawers
Démontage des tiroirs
Demontage van de lades
Демонтаж выдвижных ящиков
拆除抽屉

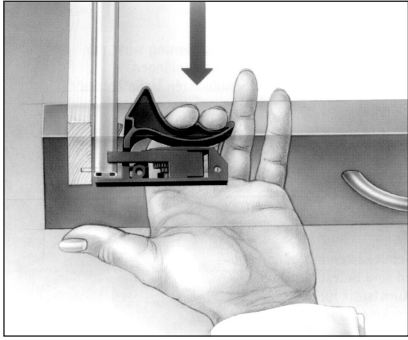

Justierung der Schubkästen

Adjustment of drawers / Réglage des tiroirs / Afstelling van de lades /
Регулировка выдвижных ящиков / 抽屉的调整

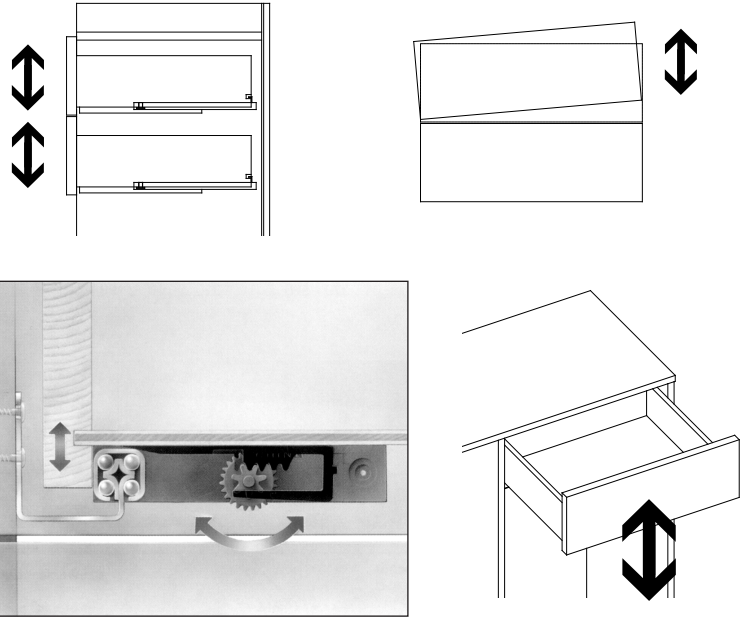

Demontage der Türen

Disassembly of doors / Démontage des portes / Demontage
van de deuren / Демонтаж дверок / 拆卸门

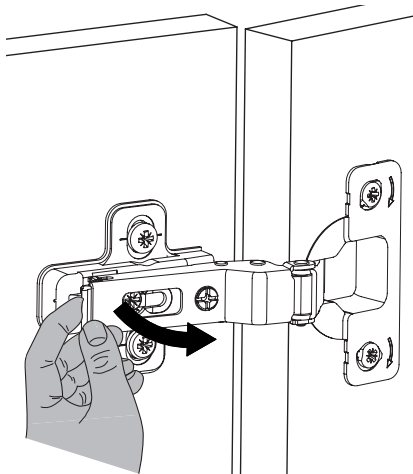

Justierung der Türen

Adjustement of doors / Réglage des portes / Afstelling van de
deuren / Регулировка дверок / 门的调整

