

Aufbauanweisung (bitte aufbewahren)

NL Opbouwinstructies (A.u.b. bewaren)

F Consignes d'assemblage (à conserver)

GB Directions for assembly (please save it)

HR Uputa sastavljanja (obavzno sačuvajte)

SLO Navodila za sestavljanje (Skrbno shranite)

H Összeszerelési útmutató (kérvük megőrizni)

SK Návod na montáž (prosím uschovať)

CZ Návod k montáži (uložte si ho prosím)

BG Инструкция за сглобяване (Моля запазете настоящата инструкция)

RO Instrucțiuni de montaj (vă rugăm, păstrați documentul)

Standardschrank MONTAGE-SCHRANKKORP.SOCKELPACK

NL Standaard kast

F Armoire standard

GB Standard wardrobe

HR Standardni ormar

SLO Standardna omara

H Szekrény szabvány szerint

SK Štandardná skriňa

CZ Standardní skříň

BG Стандартен шкаф

RO Cabinet standard

Presto

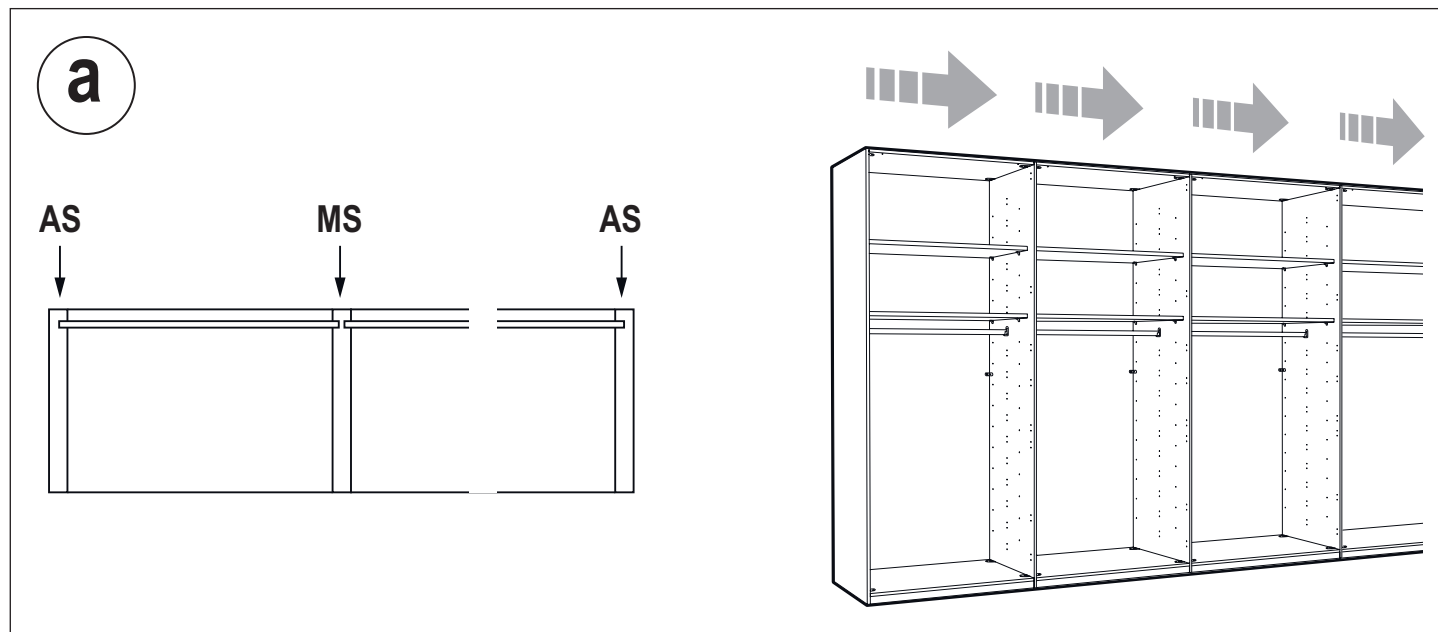

Horizont E

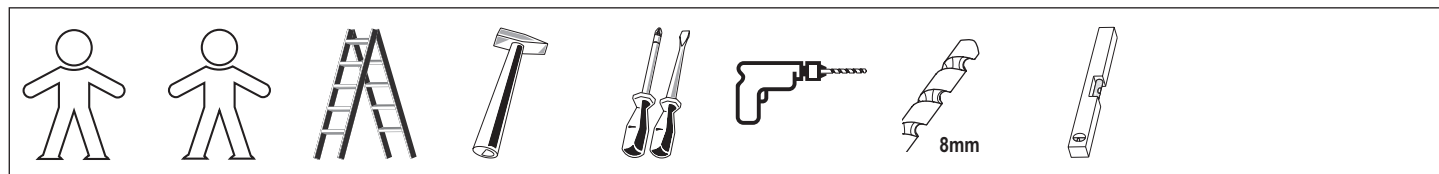
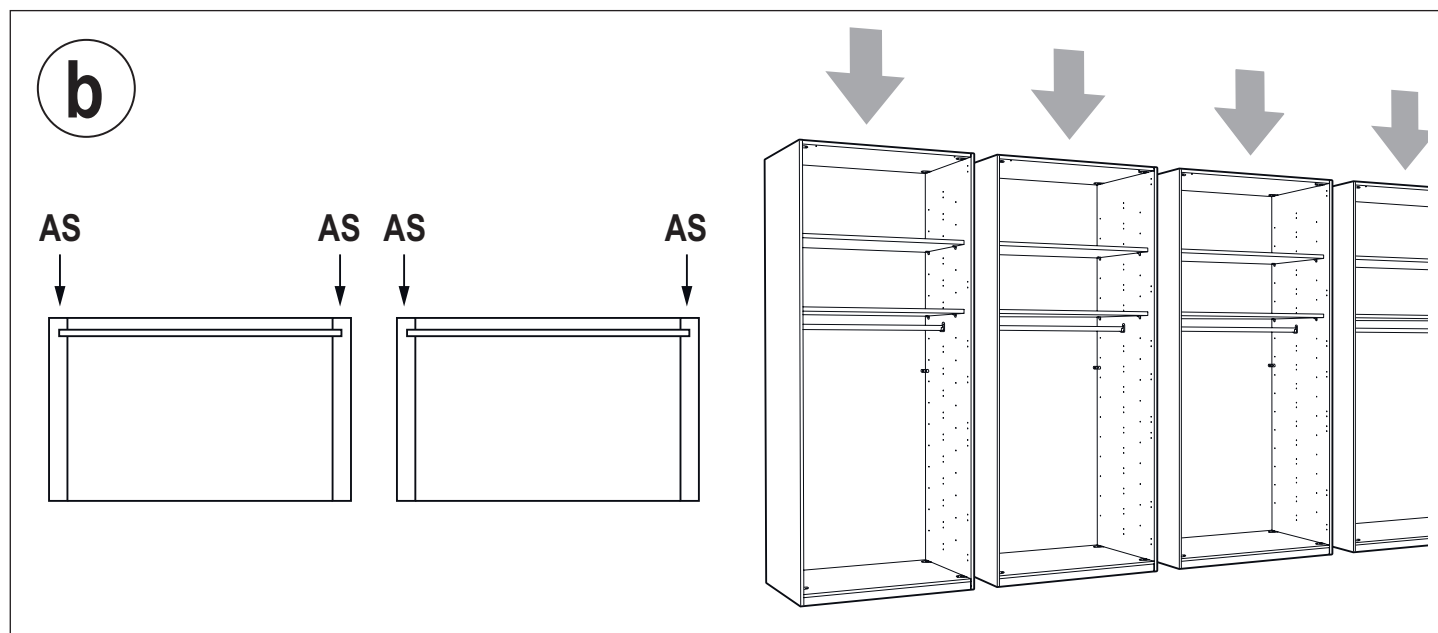

Montage nur durch Fachkräfte für Möbelmontage (FMKU)!

NL Montage alleen door specialisten!
F A ne faire monter que par les équipes spécialisées!
GB To be mounted only by mounting teams!
HR Montaža samo uz pomoć stručne osobe!
SLO Montaža samo s strani strokovnjakov!
H Az összeszerelést csak szakember végezheti!
SK Montáž smú vykonávať iba odborníci!
CZ Montáž smí provádět jen kvalifikovaný personál!
BG Монтажът трябва да се извършва само от специалисти!
RO Efectuarea montajului este permisă exclusiv specialiștilor!

Lesen Sie zuerst die Aufbauanweisung und beginnen Sie dann mit der Montage.

NL Voordat uw met de montage begint, a.u.b. de opbouw instructies lezen
F Avant de commencer avec le montage, nous vous prions de bien lire les consignes d'assemblage.
GB Before starting with the fitting, please read carefully the directions for assembly.
HR Prije montiranja pročitajte uputu za sastavljanje.
SLO Najprej preberite navodila za sestavljanje in šele nato pričnite z montažo.
H Olvassa el először az összeszerelési útmutatót, és csak ezután kezdje el a szerelést.
SK Najskôr si prečítajte návod na montáž a až potom začnite s montážou.
CZ Návod k montáži si nejdříve přečtěte a pak začněte s montáží.
BG Първо прочетете инструкцията заглобяване и след това започнете с монтажа.
RO Mai întâi citiți instrucțiunile de montaj, și numai după aceea începeți montajul.

Bei nicht vorschriftsmäßiger und/oder nicht fachmännischer Montage wird für Personen- oder Sachschäden keinerlei Haftung übernommen.

NL In geval van persoonlijke ongelukken en materiële schade is aansprakelijkheid uitgesloten, indien de montage niet overeenkomstig de voorschriften en/of niet door een vakman werd uitgevoerd.
F Nous déclinons toute responsabilité en cas de dommages corporels ou matériels dus à un montage non conforme aux instructions et/ou exécuté incorrectement.
GB We will not accept any liability in case of personal injury or material damages, if not assembled according to the regulations and/or by specialists.
HR U slučaju nepropisane i/ili ne stručne montaže ne preuzimamo odgovornost za nastanak štete osobama ili stvarima.
SLO Pri montaži brez upoštevanja navodil in/ali pri nestrokovni montaži se ne prevzame nikakršne odgovornosti za telesne poškodbe ali materialno škodo.
H A nem előírás szerint és/vagy nem szakemberrel végzett összeszerelés esetén felmerülő személyi és anyagi károkért semmilyen felelősséget nem vállalunk.
SK V prípade montáže v rozpore s predpismi a/alebo neodbornej montáže nepreberáme v prípade ujmy na zdraví alebo vecných škôd žiadnu záruku.
CZ Při montáži v rozporu s předpisy nebo při neodborné montáži nepřebírá výrobce žádnou záruku za škody vzniklé na osobách nebo předmětech.
BG Ако монтажът не е извършен съгласно инструкцията и/или от специалисти, фирмата не поема отговорност в случай на нараняване на хора или при материални щети.
RO În caz de montaj efectuat necorespunzător și/sau neprofesionist nu ne asumăm niciun fel de responsabilitate pentru vătămarea persoanelor sau pentru pagubele materiale.

Beschlagsübersicht: letzte Seite

NL Beslagoverzicht: laatste pagina GB Fitting survey: last page SLO Seznam sestavnih delov: zadnja stran SK Prehľad kování: posledná strana BG Монтажни елементи: последна страница
F Tableau de quincaillerie: dernière page HR Pregled dijelova: posljednja stranica H Kötőelem áttekintés: utolsó oldal CZ Přehled kování: poslední stránka RO Vedere de ansamblu: ultima pagină

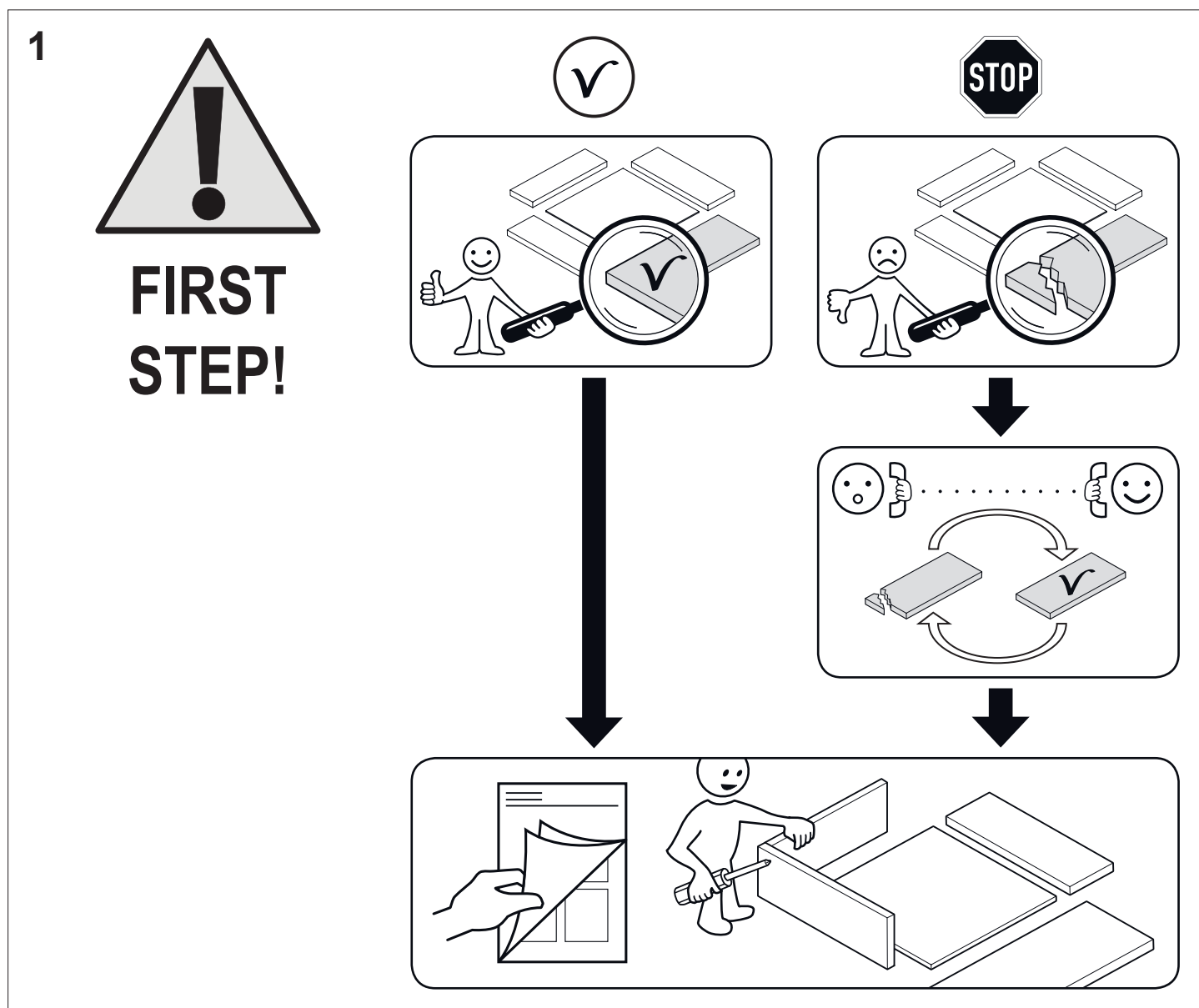

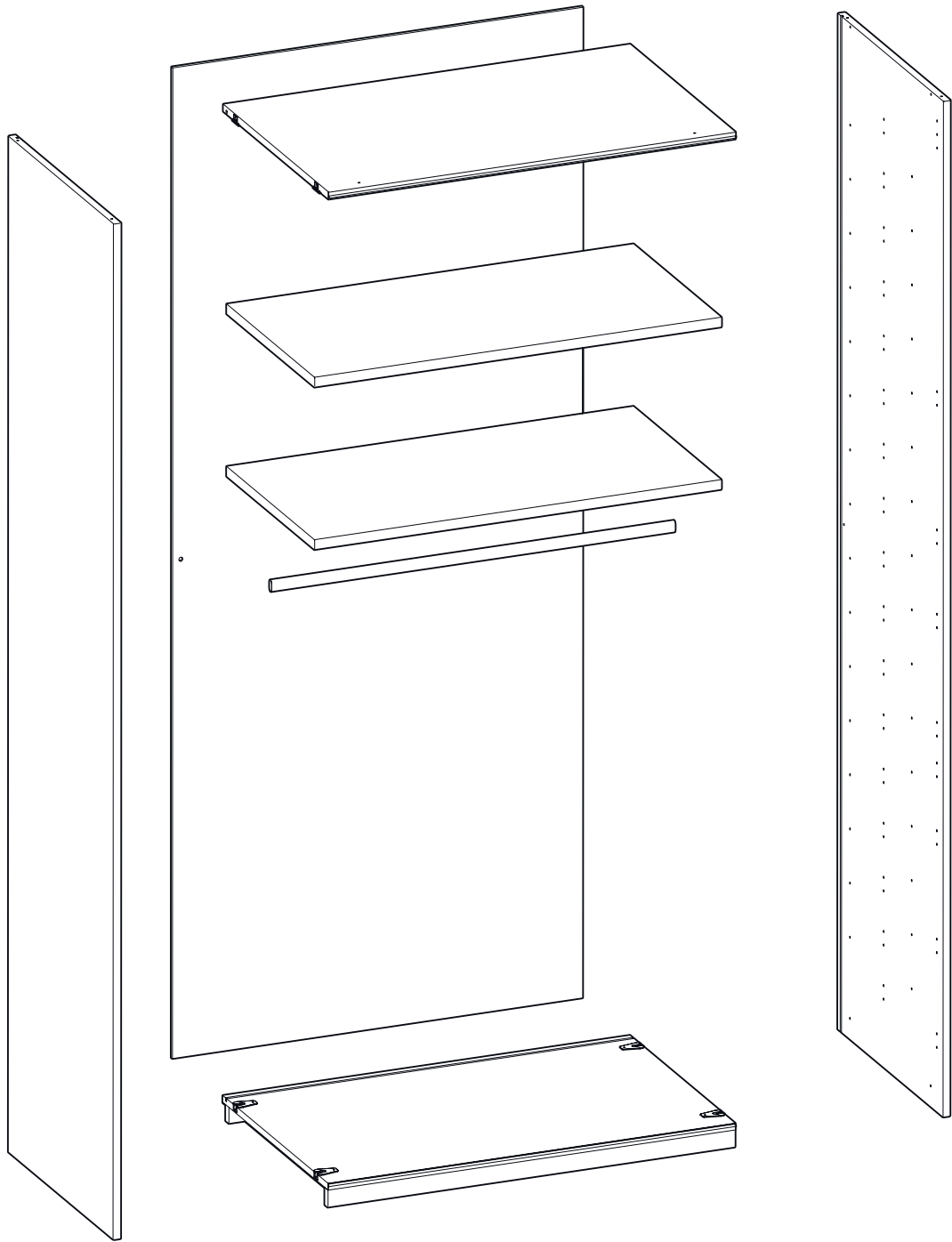

2

Boden mit Wasserwaage nach allen Richtungen exakt ausrichten!

- NL Bodem met waterpas horizontaal plaatsen!
 F Aligner la tablette avec le niveau à bulle d'air
 GB Align base unit with a spirit level!
 HR Uz pomoć libele poravnajte pod u svim smjerovima!
 SLO Tla izravajte z libelo natančno v vse smeri!
 H A talajt vízszintezővel minden irányban pontosan ki kell egyenesíteni.
 SK S pomocou libely skontrolujte, či je Vaša podlaha rovná na všetkých miestach.
 CZ Dno přesně vyrovnejte vodováhou ve všech směrech!
 BG Подравнете прецизно пода във всички посоки с нивелир!
 RO Aliniați baza dulapului în toate direcțiile cu o nivelă cu bulă de aer!

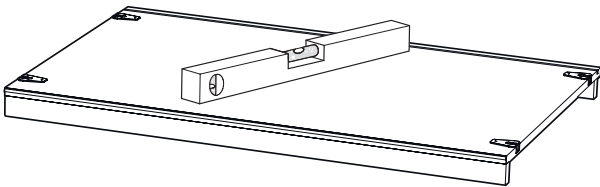

3

022900

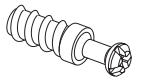

BO-014/5*12

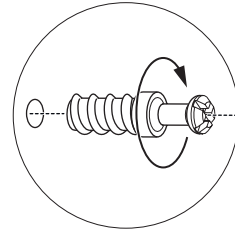
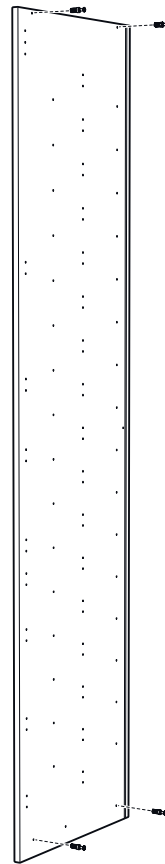

Aussenseite

- NL Buitenzijde
 F Côté extérieur
 GB End panel
 HR Vanjska stranica
 SLO zunanja stranica
 H külső oldal
 SK vonkajšia strana
 CZ vnější strana
 BG външна преграда
 RO Panou exterior

4

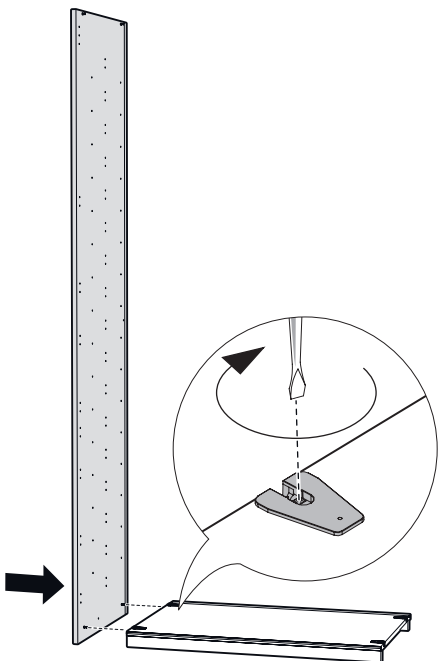

5

165160

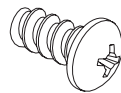

EU6,3*12HRUKO

165150

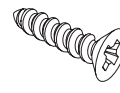

SX3,5*16FLAKO

567221

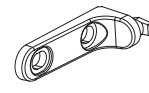

RW-WINKEL-5MM

578606



RW-WINKEL-39/15

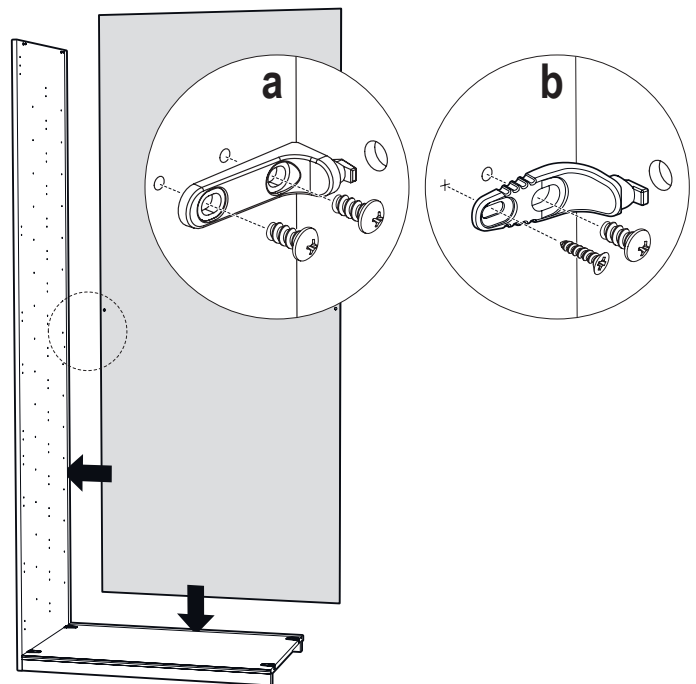

6 a

022970

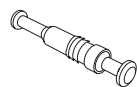

DB-DU706 5*34

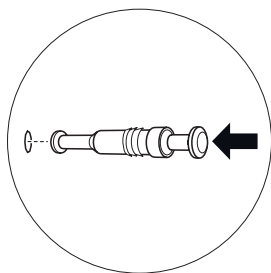
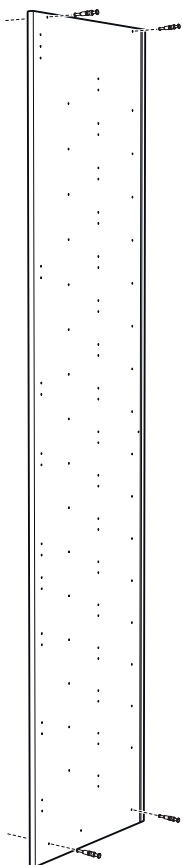
**Mittelseite**

- NL Middenzijde
- F Cloison de séparation
- GB Middle side panel
- HR Srednja stranica
- SLO srednja stranica
- H középső oldal
- SK prostredná strana
- CZ prostřední strana
- BG средна преграда
- RO Panou separator

6 b

022900

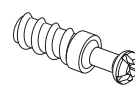

BO-014/5*12

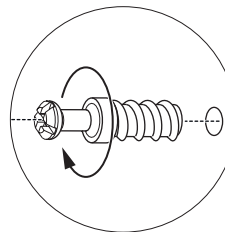
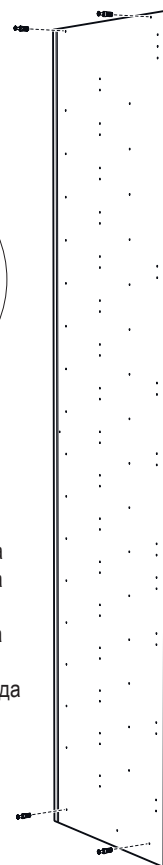
**Aussenseite**

- NL Buitenzijde
- F Côte extérieur
- GB End panel
- HR Vanjska stranica
- SLO zunanja stranica
- H külső oldal
- SK vonkajšia strana
- CZ vnější strana
- BG външна преграда
- RO Panou exterior

7

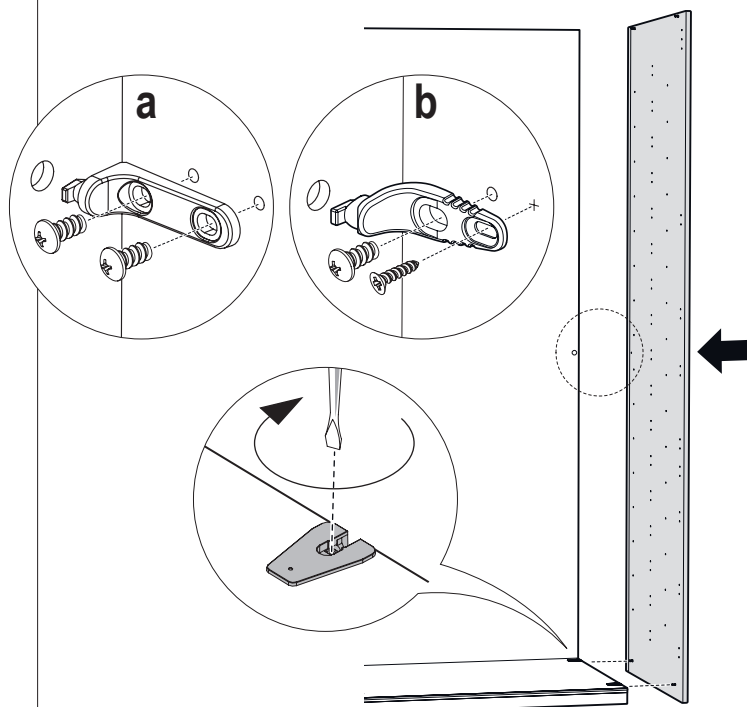

8

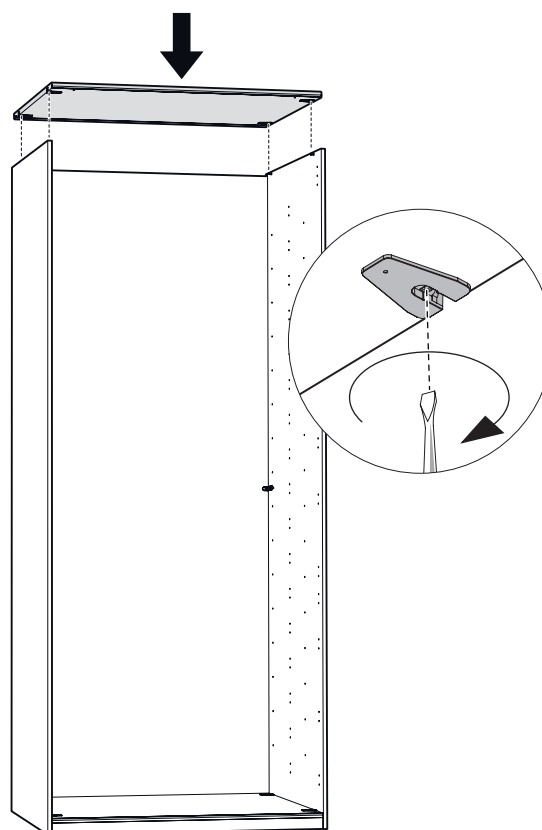

9 a

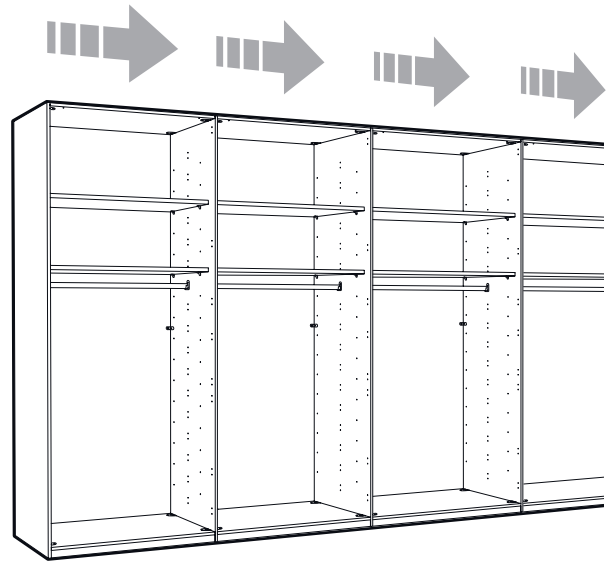
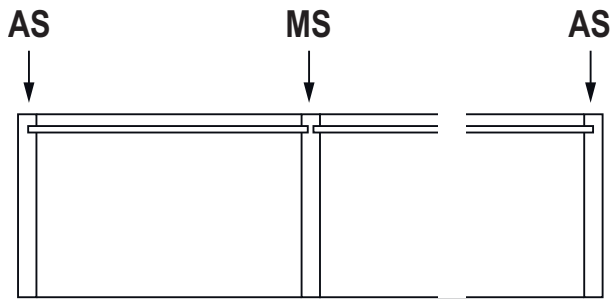

9 b

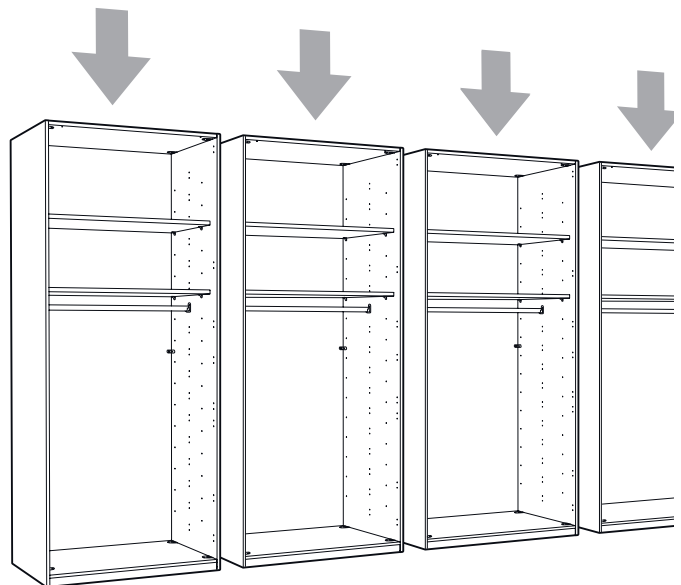
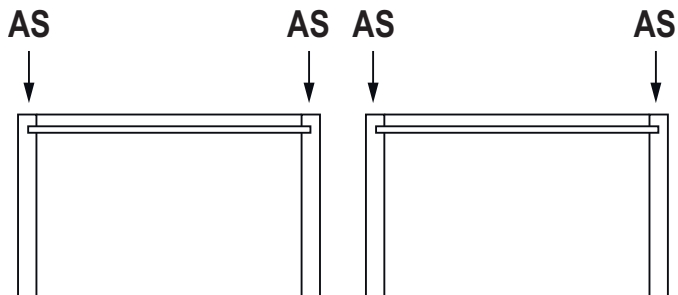

10

567281

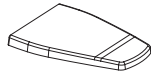

ABDECKK-RAFIX

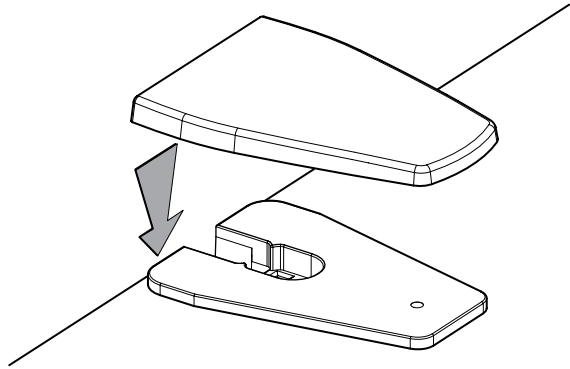

11

011580



ABDECKK-05MM

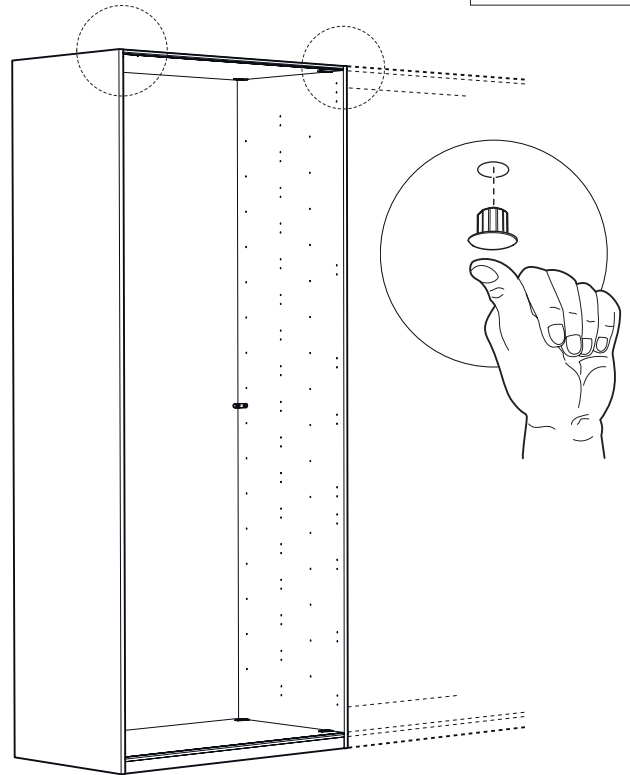

12

165150

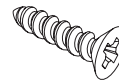

SX3,5*16FLAKO

517710

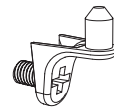

BOTR-STIFT/EU

518710

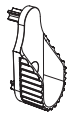

SCHRLA-METALL

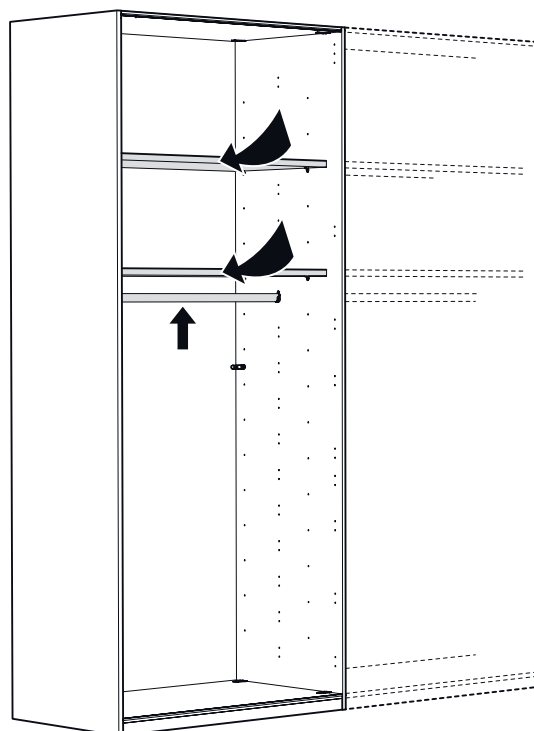
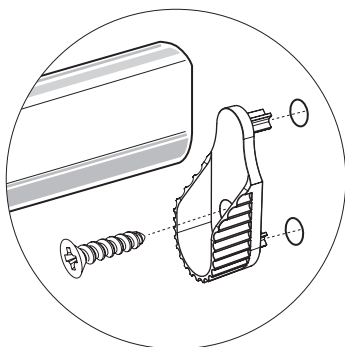
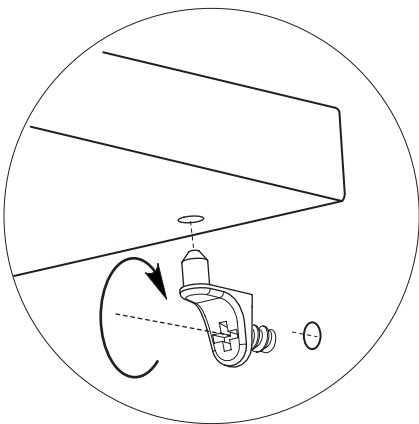

13



ACHTUNG!

Aus Sicherheitsgründen muss das Möbelteil an der Wand befestigt werden. Beiliegendes Befestigungsmaterial eignet sich nur für Massivwände. Für andere Wände müssen Spezialdübel verwendet werden.

- NL LET OP!** Uit veiligheidsoverwegingen moet het meubeldeel aan de wand bevestigd worden. Bijgevoegt bevestigings materiaal is alleen bruikbaar voor massieve wanden. Voor andere wanden moeten speciale schroeven gebruikt worden.
- F ATTENTION!** Pour des raisons de sécurité le meuble doit être fixé au mur. Le matériel ci-joint est approprié pour des murs épais. Pour d'autres murs utiliser des chevilles spéciales.
- GB ATTENTION!** For safety reasons please fix the unit to the walls. Enclosed fittings for stoned wall only. For other walls please use other pegs.
- HR OPREZ!** Zbog sigurnosnih razloga namještaj morate pričvrstiti na zid. Materijal za pričvršćivanje koji je u priloženju možete koristiti samo na masivne zidove. Za ostale vrste zidova morate koristiti posebne tiplove.
- SLO POZOR!** Iz varnostnih razlogov je potrebno del pohištvá pritrđiti na steno. Priložen material za pritrđitev je primeren samo za masivne stene. Za druge stene je potrebno uporabiti posebne vložke.
- H FIGYLEM!** Biztonsági okokból a bútordarabot a falhoz kell erősíteni. A mellékelt rögzítőanyag csak masszív falaknál alkalmazható. Egyéb falaknál speciális tiplét kell használni.
- SK POZOR!** Z bezpečnostných dôvodov musí byť táto časť nábytku pripevnená na stenu. Priložený materiál na upevnenie sa hodí len pre masívne steny. Pre ostatné druhy stien použite špeciálne hmoždinky.
- CZ POZOR!** Z bezpečnostních důvodů musí být nábytek upevněn ke stěně. Přiložený materiál k upevnění ke stěně je vhodný pouze k použití na masivních zdech. Na jiné stěny musí být použity speciální hmoždinky.
- BG ВНИМАНИЕ!** От съображения за сигурност мебелите трябва да бъдат закрепени към стената. Приложените закрепващи приспособления са подходящи само за масивни стени. За други видове стени трябва да се използват специални дюбели.
- RO PERICOL** Din motive de siguranță, piesa de mobilier trebuie fixată pe perete. Materialul de fixare inclus în pachetul de livrare este adecvat numai pentru pereți masivi. Pentru alte tipuri de pereți trebuie utilizate dibluri speciale.

028890

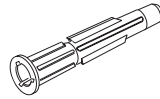

KU-DUEBEL-8MM/ALLZWECK

500570

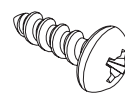

SX5,0*15RUKO

566407



SX4,5*60FLAKO/S-CAP

573057

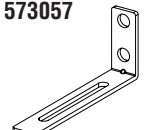

WINKEL-100x40x16-WANDBEF

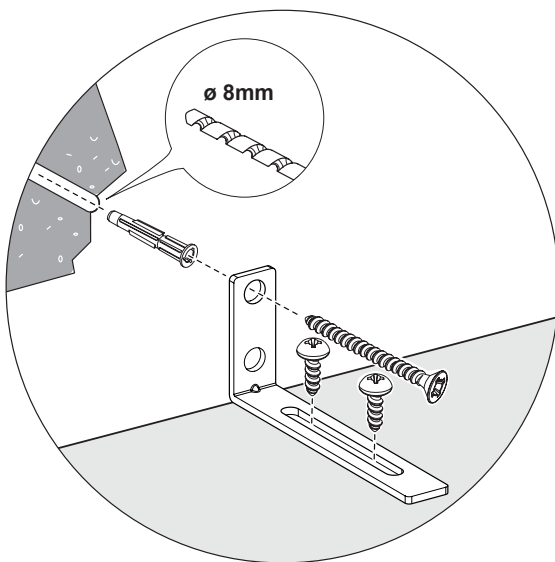
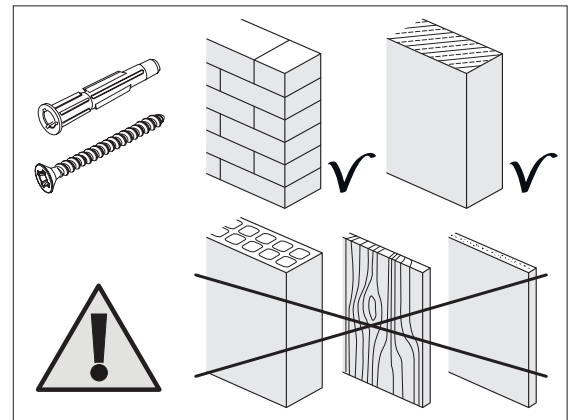

Boden mit Wasserwaage nach allen Richtungen exakt ausrichten!

- NL** Bodem met waterpas horizontaal plaatsen!
- F** Aligner la tablette avec le niveau à bulle d'air
- GB** Align base unit with a spirit level!
- HR** Uz pomoć libele poravnajte pod u svim smjerovima!
- SLO** Tla izravnajte z libelo natančno v vse smeri!
- H** A talajt vízszintezővel minden irányban pontosan ki kell egyenesíteni.
- SK** S pomocou libely skontrolujte, či je Vaša podlaha rovná na všetkých miestach.
- CZ** Dno přesně vyrovnejte vodováhou ve všech směrech!
- BG** Подравнете прецизно пода във всички посоки с нивелир!
- RO** Aliniați baza dulapului în toate direcțiile cu o nivelă cu bulă de aer!

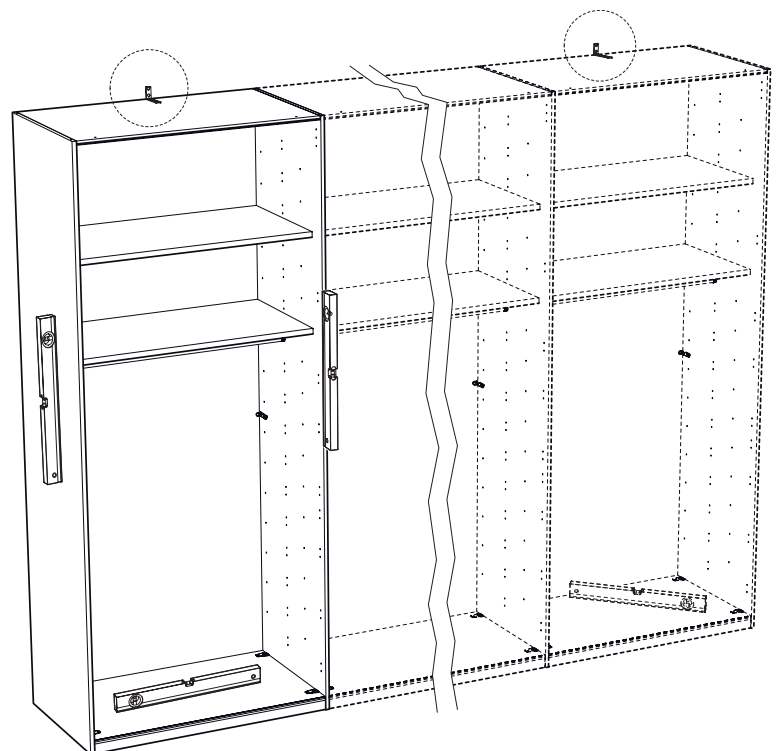

Servicekarte

NL Servicekaart GB Service card SLO Servisna kartica SK Servisná karta BG Сервизна карта
 F Carte de service HR Servisna karta H Szervíz kártya CZ Servisní karta RO Carte de service

Nolte Möbel GmbH&Co.KG, Konrad-Nolte-Straße 20, 76726 Gernersheim, Tel.: 0049-7274/51-120, Fax: 0049-7274/51-12210 www.nolte-moebel.de

Sorgfalt bei der Produktion und der Endkontrolle garantieren mängelfreie Beschaffenheit unserer Produkte. Sollten Sie dennoch Grund zu einer Mängelrüge haben, so senden Sie bitte diese Servicekarte und bei Bedarf die markierte Aufbauanweisung an Ihren Händler.

- NL Zorgvuldigheid bij de productie en de eindcontrole garanderen dat onze producten vrij zijn van gebreken. Indien u toch klachten heeft, stuur dan alsblijft bijgaande servicekaart en zo nodig de montagehandleiding met toelichting naar uw verkoper.
- F Nous veillons soigneusement à la qualité impeccable de nos produits pendant la production et avec le contrôle avant le chargement. Si toutefois, vous êtes amenés à nous adresser une réclamation, nous vous prions de nous joindre la carte de service et la notice de montage sur lesquelles vous aurez marqué la pièce en question.
- GB Our production techniques and final quality inspections ensure that our products are faultlessly manufactured. However, if you should have any reason for complaint, please send the service card to your dealer, if necessary enclosing the assembly instructions to indicate the faulty part.
- HR Pozornost prilikom proizvodnje i finalne kontrole jamče besprijekorno stanje naših proizvoda. Imate li ipak osnova za reklamaciju, molimo da tada pošaljete priloženu servisnu kartu i prema potrebi označeno uputstvo za sklapanje vašem trgovcu.
- SLO Skbnost pri izdelavi in zaključni kontroli zagotavlja izdelavo naših produktov brez napak. V primeru, da imate razlog za pritožbo, Vas prosimo da svojemu trgovcu pošljete pritrjeno servisno kartico in po potrebi tudi označeno navodilo glede sestavljanja.
- H A gondosság a gyártás és a végső ellenőrzés során garantálja termékeink hibátlan minőségét. Ha Önnek ennek elnére is oka lenne az áru kellékhányának bejelentésére, úgy kérem küldje el a mellékelt szervizkártyát és szükség esetén a megjelölt összeszerelési útmutatót kereskedőjének.
- SK Dôslednosť pri výrobe a výstupnej kontrole je zárukou bezchybných vlastností našich výrobkov. Ak však aj napriek tomu máte dôvod na reklamáciu, zašlite priloženú servisnú kartu a v prípade potreby označený návod na montáž svojmu predajcovi.
- CZ Pečlivost během výroby a výstupní kontrola zaručují technicky bezvadné vlastnosti našich produktů. Pokud byste přesto měli důvod k reklamaci, zašlete svému obchodníkovi přiloženou servisní kartu a v případě potřeby také označený návod k montáži.
- BG Прецизността при производството и при крайния контрол гарантират отличното качество на нашите продукти. Ако въпреки това имате основание за reklamacия, моля изпратете на Вашия продавач приложената сервизна карта, а при нужда - маркираната инструкция за сглобяване.
- RO Atenția în timpul producției și la verificarea finală garantează calitatea impecabilă a produselor noastre. Dacă totuși aveți motive de reclamație din cauza unor deficiențe de calitate, trimiteți distribuitorului dumneavoastră cartea de service atașată și - dacă este nevoie - instrucțiunea de montaj marcată.

Standardschrank MONTAGE-SCHRANKKORP.SOCKELPACK

Typ

NL Type GB Type SLO Tip SK Typ
 BG Вид F Type HR Tip H Tipus CZ Typ RO Tip

Datum

NL Date GB Date SLO Datum SK Dátum
 BG Дата F Date HR Datum H Dátum CZ Datum RO Data

Kaufvertragsnummer / Lieferscheinnummer

Fehlerursache





- NL Koopcontract nr. / vervoerdocument nr.
 F No. contrat d'achat / no. bon de livraison
 GB Purchase contract no. / delivery note no.
 HR Broj prodajnog ugovora / Broj otpравnice
 SLO Številka kupoprodajne pogodbe / Številka dostavnice
 H Numărul contractului de achiziționare / numărul bonului de livrare
 SK Vételi szerződés száma / Szállítólevél száma
 CZ Číslo kúpnej zmluvy / číslo dodacieho listu
 BG № на договора за продажба / № на деливъри ордера
 RO C.kupni smlouvy / číslo dodacieho listu

- NL Oorzaak van het gebrek H Hiba oka
 F Raison de la réclamation SK Příklad chyby
 GB Reason for complaint CZ Příčina závady
 HR Uzrok greške BG Причина за дефекта
 SLO Vzrok napake RO Cauza defecțiunilor

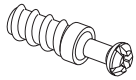
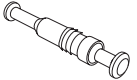
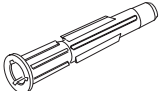
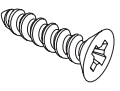
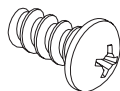
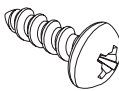
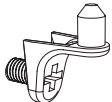

Beschlagsübersicht

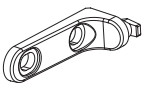
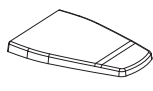
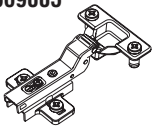
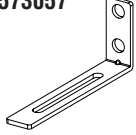
NL Beslagoverzicht GB Fitting survey SLO Seznam sestavnih delov SK Prehľad kovaní BG Монтажни елементи
 F Tableau de quincaillerie HR Pregled dijelova H Kötőelem áttekintés CZ Přehled kování RO Vedere de ansamblu

011580  ABDECKK-05MM	022900  BO-014/5*12	022970  DB-DU706 5*34	028890  KU-DUEBEL-8MM/ALLZWECK	165150  SX3,5*16FLAKO	165160  EU6,3*12HRUKO	500570  SX5,0*15RUKO	517710  BOTR-STIFT/EU
518710  SCHRLA-METALL	566407  SX4,5*60FLAKO/S-CAP	567221  RW-WINKEL-5MM	567281  ABDECKK-RAFIX	569005  TBW-M-35/5/13-K9+H6	573057  WINKEL-100x40x16-WANDBEF	578606  RW-WINKEL-39/15	

Aufbauanweisung (bitte aufbewahren)

NL	Opbouw instructies (A.u.b. bewaren)	H	Összeszerelési útmutató (kérjük megőrizni)
F	Consignes d'assemblage (à conserver)	SK	Návod na montáž (prosím uschovat)
GB	Directions for assembly (please save it)	CZ	Návod k montáži (uložte si ho prosím)
HR	Uputa sastavljanja (obavzno sačuvajte)	BG	Инструкция за сглобяване (Моля запазете настоящата инструкция)
SLO	Navodila za sestavljanje (Skrbno shranite)	RO	Instrucțiuni de montaj (vă rugăm, păstrați documentul)

Türenmontage

NL	Deurenmontage
F	Montage des portes
GB	Assembly of doors
HR	Montaža vratiju
SLO	Montaža vrat
H	Ajtószerelés
SK	Montáž dverí
CZ	Montáž dveří
BG	Монтаж на врати
RO	asamblare usa

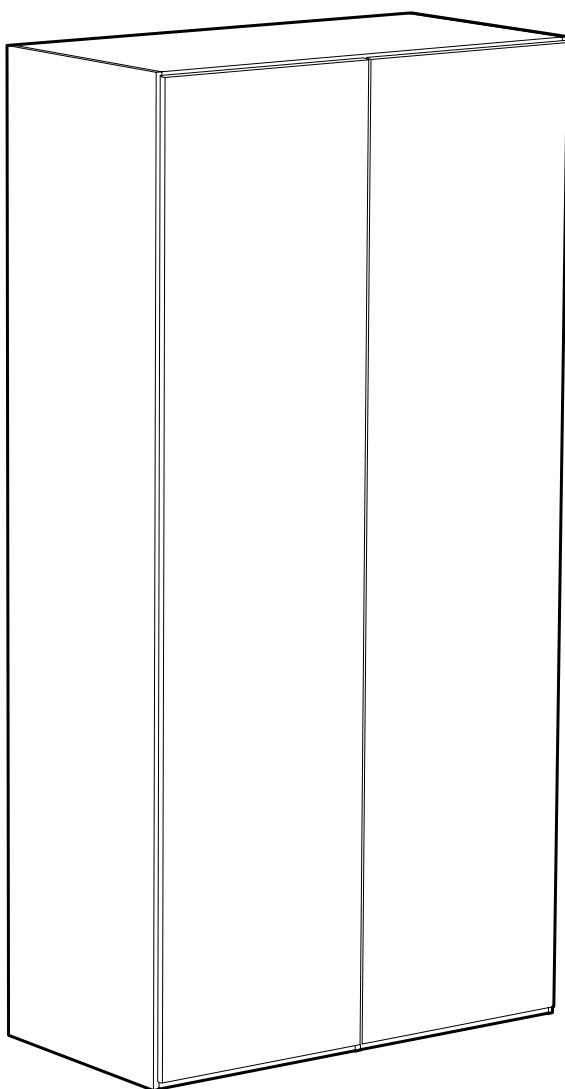

modellabhängig

NL	modelafhankelijk
F	le modèle choisi
GB	the chosen model
HR	ovisno o modelu
SLO	odvisno od modela
H	modellfüggő
SK	závislé od modelu
CZ	podle modelu
BG	в зависимост от модела
RO	depinde de model

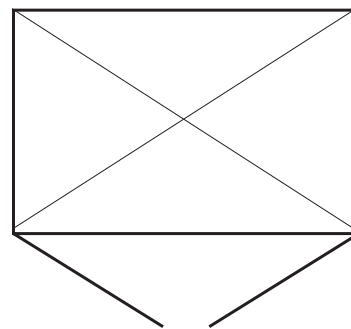

Montage nur durch Fachkräfte für Möbelmontage (FMKU)!

NL Montage alleen door specialisten!
 F A ne faire monter que par les équipes spécialisées!
 GB To be mounted only by mounting teams!
 HR Montaža samo uz pomoć stručne osobe!
 SLO Montaža samo s strani strokovnjakov!
 H Az összeszerelést csak szakember végezheti!
 SK Montáž smú vykonávať iba odborníci!
 CZ Montáž smí provádět jen kvalifikovaný personál!
 BG Монтажът трябва да се извършва само от специалисти!
 RO Efectuarea montajului este permisă exclusiv specialiștilor!

Lesen Sie zuerst die Aufbauanweisung und beginnen Sie dann mit der Montage.

NL Voordat uw met de montage begint, a.u.b. de opbouw instructies lezen
 F Avant de commencer avec le montage, nous vous prions de bien lire les consignes d'assemblage.
 GB Before starting with the fitting, please read carefully the directions for assembly.
 HR Prije montiranja pročitajte uputu za sastavljanje.
 SLO Najprej preberite navodila za sestavljanje in šele nato pričnite z montažo.
 H Olvassa el először az összeszerelési útmutatót, és csak ezután kezdje el a szerelést.
 SK Najskôr si prečítajte návod na montáž a až potom začnite s montážou.
 CZ Návod k montáži si nejdříve přečtěte a pak začněte s montáží.
 BG Първо прочетете инструкцията заглобяване и след това започнете с монтажа.
 RO Mai întâi citiți instrucțiunile de montaj, și numai după aceea începeți montajul.

Bei nicht vorschriftsmäßiger und/oder nicht fachmännischer Montage wird für Personen- oder Sachschäden keinerlei Haftung übernommen.

NL In geval van persoonlijke ongelukken en materiële schade is aansprakelijkheid uitgesloten, indien de montage niet overeenkomstig de voorschriften en/of niet door een vakman werd uitgevoerd.
 F Nous déclinons toute responsabilité en cas de dommages corporels ou matériels dus à un montage non conforme aux instructions et/ou exécuté incorrectement.
 GB We will not accept any liability in case of personal injury or material damages, if not assembled according to the regulations and/or by specialists.
 HR U slučaju nepropisane i/ili ne stručne montaže ne preuzimamo odgovornost za nastanak štete osobama ili stvarima.
 SLO Pri montaži brez upoštevanja navodil in/ali pri nestrokovni montaži se ne prevzame nikakršne odgovornosti za telesne poškodbe ali materialno škodo.
 H A nem előírás szerint és/vagy nem szakemberrel végzett összeszerelés esetén felmerülő személyi és anyagi károkért semmilyen felelősséget nem vállalunk.
 SK V prípade montáže v rozpore s predpismi a/alebo neodbornej montáže nepreberáme v prípade ujmy na zdraví alebo vecných škód žiadnu záruku.
 CZ Při montáži v rozporu s předpisy nebo při neodborné montáži nepřebírá výrobce žádnou záruku za škody vzniklé na osobách nebo předmětech.
 BG Ако монтажът не е извършен съгласно инструкцията и/или от специалисти, фирмата не поема отговорност в случай на нараняване на хора или при материални щети.
 RO În caz de montaj efectuat necorespunzător și/sau neprofesionist nu ne asumăm niciun fel de responsabilitate pentru vătămarea persoanelor sau pentru pagubele materiale.

Beschlagsübersicht

NL Beslagoverzicht GB Fitting survey SLO Seznam sestavnih delov SK Prehľad kování BG Монтажни елементи
 F Tableau de quincaillerie HR Pregled dijelova H Kötőelem áttekintés CZ Přehled kování RO Vedere de ansamblu

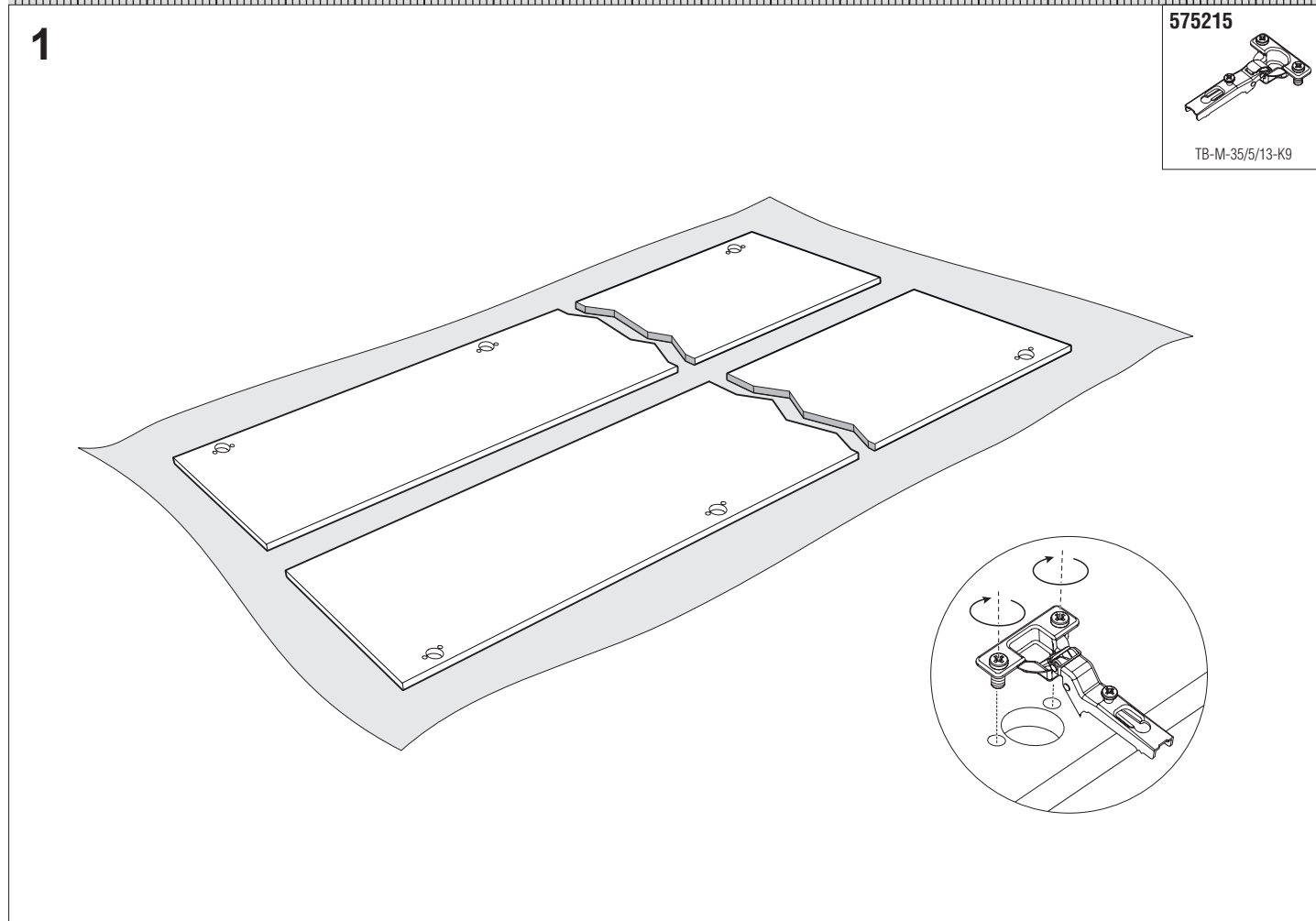
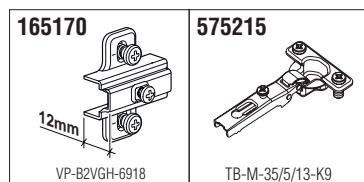

2

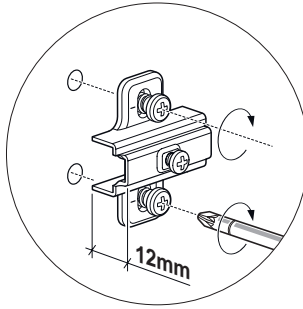
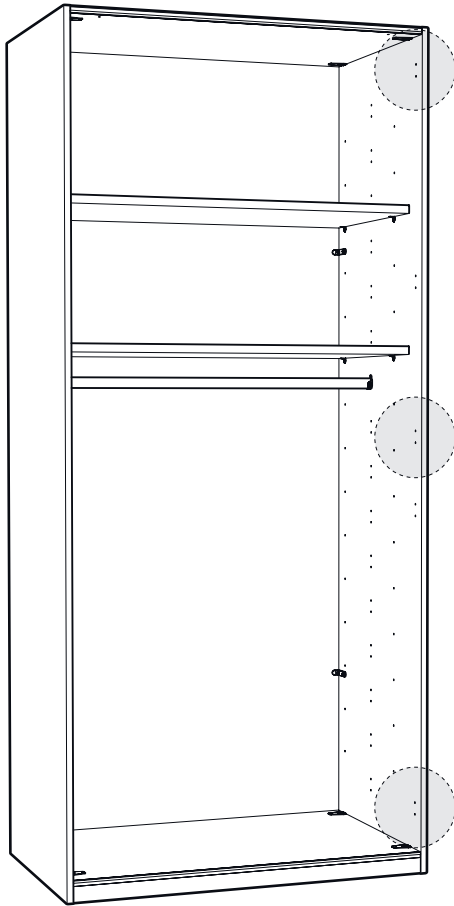

165170

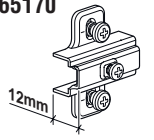

VP-B2VGH-6918

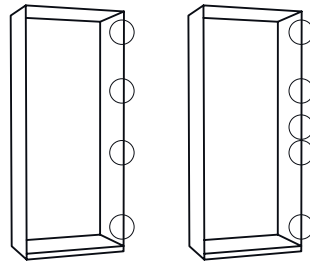

modellabhängig

- NL modelafhankelijk
- F le modèle choisi
- GB the chosen model
- HR ovisno o modelu
- SLO odvisno od modela
- H modellfüggő
- SK závislé od modelu
- CZ podle modelu
- BG в зависимост от модела
- RO depinde de model

3

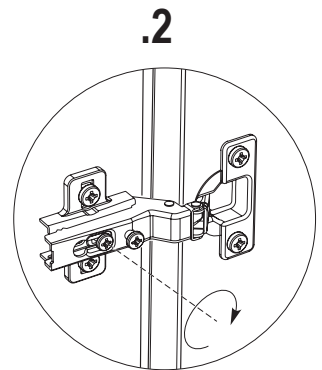
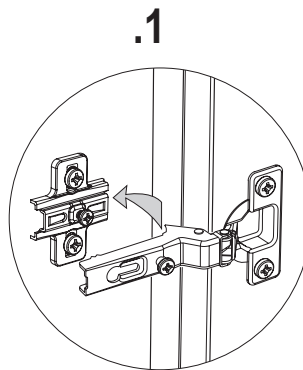
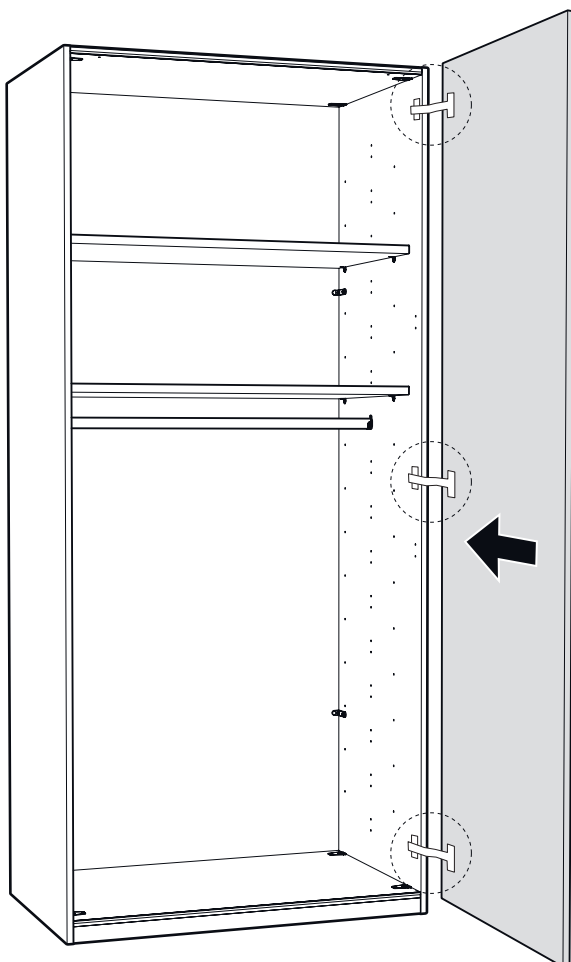

4 Ausrichten der Tür in waagerechter Richtung und Einstellen des Fugenabstandes

- NL Horizontale afstelling van de deur en instellen van de voegafstand
 F Ajuster la porte a l'horizontale et regler l'espace entre les joints
 GB Adjust the door in a horizontal line and regulate the distance between the joints
 HR Podešavanje vrata u horizontalnom položaju i namještanje razmaka spojeva
 SLO Naravnjanje vrat v vodoravni smeri in nastavitve razdalje stika
 H Az ajtó vízszintes irányú igazítása és a réstávolság beállítása
 SK Vyrovnánie dverí v horizontálnom smere a nastavenie odstupeu medzery
 CZ Vyrovnání dveří ve vodorovném směru a nastavení vzdálenosti spár
 BG Регулиране на вратата в хоризонтална посока и настройване на разстоянието между фугите
 RO Aliniați ușa în direcție orizontală și reglați distanța dintre rosturi

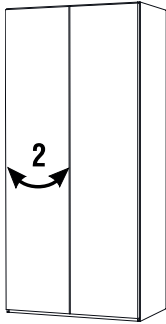

1. Lösen der Befestigungsschrauben

- NL Losdraaien van de bevestigingsschroeven
 F Devisser les vis
 GB Release the screws
 HR Odvijanje pričvrstnog vijka
 SLO Zrahljanje vijakov za pritrditev
 H Állítsa függőlegesre az ajtót
 SK Uvoľnite upevňovacie skrutky
 CZ Povolte upevňovací šrouby
 BG Разхлабване на крепежните винтове
 RO Slăbiți șurubul de fixare

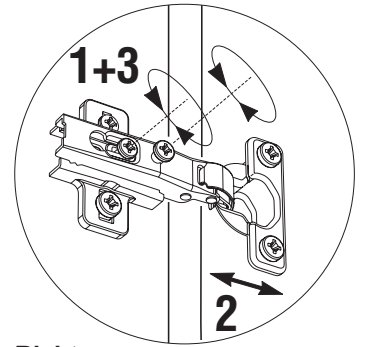

2. Ausrichten der Tür mit der Verstellechraube in waagerechter Richtung

- NL Waterpas afstellen van de deur met de verstellechroef (horizontaal)
 F Ajuster la porte avec la vis de réglage à l'horizontale
 GB Adjust the door with the adjusting screw in a horizontal line
 HR Podešavanje vrata u horizontalnom položaju uz pomoć vijka za podešavanje
 SLO Naravnjanje vrat v vodoravni smeri s pomočjo vijaka za nastavitve
 H Állítsa be az ajtó vízszintes irányban a beállító csavarral
 SK Vyrovnánie dverí v horizontálnom smere pomocou regulačnej skrutky
 CZ Dveře vyrovnejte ve vodorovném směru pomocí stavěcího šroubu
 BG Регулиране на вратата в хоризонтална посока с регулиращия винт
 RO Aliniați ușa în direcție orizontală cu șurubul de reglare

3. Anziehen der Befestigungsschrauben

- NL Andraaien van de bevestigingsschroeven
 F Serrer les vis
 GB Tighten the screws
 HR Zavrtnanje pričvrstnog vijka
 SLO Zategnitev vijakov za pritrditev
 H Szorítsa meg a rögzítő csavart
 SK Utiahnite upevňovacie skrutky
 CZ Upevňovací šroub utáhněte
 BG Затягане на крепежните винтове
 RO Strângeți șurubul de fixare

5 Ausrichten der Tür in senkrechter Richtung

- NL Vertikale afstelling van de deur
 F Ajuster la porte a la verticale
 GB Adjust the door in a vertical line
 HR Postavljanje vrata u uspravan položaj
 SLO Naravnjanje vrat v navpični smeri
 H Az ajtó függőleges irányú igazítása
 SK Vyrovnánie dverí vo vertikálnom smere
 CZ Vyrovnání dveří ve svislém směru
 BG Регулиране на вратата във вертикална посока
 RO Aliniați ușa în direcție verticală

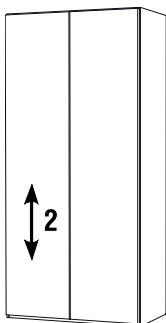

1. Lösen der Befestigungsschrauben

- NL Losdraaien van de bevestigingsschroeven
 F Devisser les vis
 GB Release the screws
 HR Odvijanje pričvrstnog vijka
 SLO Zrahljanje vijakov za pritrditev
 H Állítsa függőlegesre az ajtót
 SK Uvoľnite upevňovacie skrutky
 CZ Povolte upevňovací šrouby
 BG Разхлабване на крепежните винтове
 RO Slăbiți șurubul de fixare

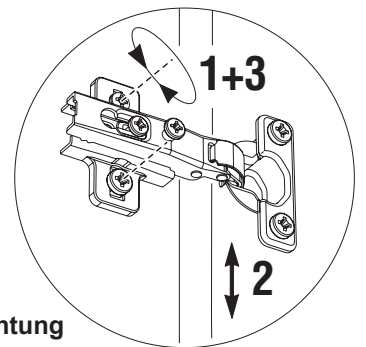

2. Ausrichten der Tür in senkrechter Richtung

- NL Vertikale afstellen van de deur
 F Ajuster la porte a la verticale
 GB Adjust the door in a vertical line
 HR Postavljanje vrata u uspravan položaj
 SLO Naravnjanje vrat v navpični smeri
 H Állítsa függőlegesre az ajtót
 SK Vyrovnajte dvere vo vertikálnom smere
 CZ Dveře vyrovnejte ve svislém směru
 BG Регулиране на вратата във вертикална посока
 RO Aliniați ușa în direcție verticală

3. Anziehen der Befestigungsschrauben

- NL Andraaien van de bevestigingsschroeven
 F Serrer les vis
 GB Tighten the screws
 HR Zavrtnanje pričvrstnog vijka
 SLO Zategnitev vijakov za pritrditev
 H Szorítsa meg a rögzítő csavart
 SK Utiahnite upevňovacie skrutky
 CZ Upevňovací šroub utáhněte
 BG Затягане на крепежните винтове
 RO Strângeți șurubul de fixare

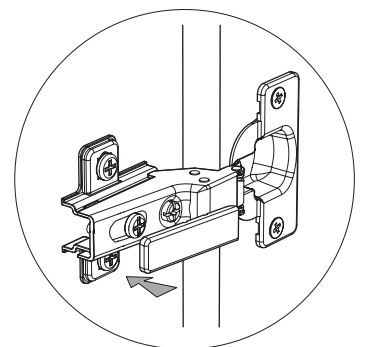

6

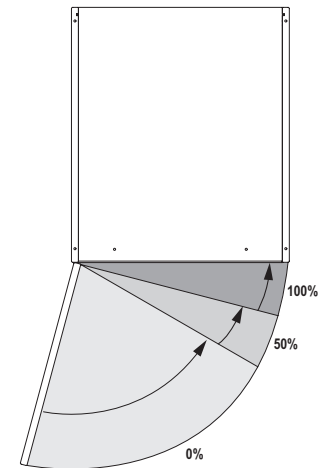
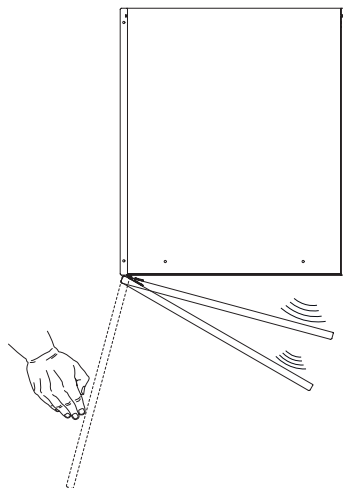
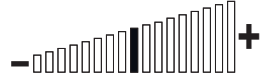
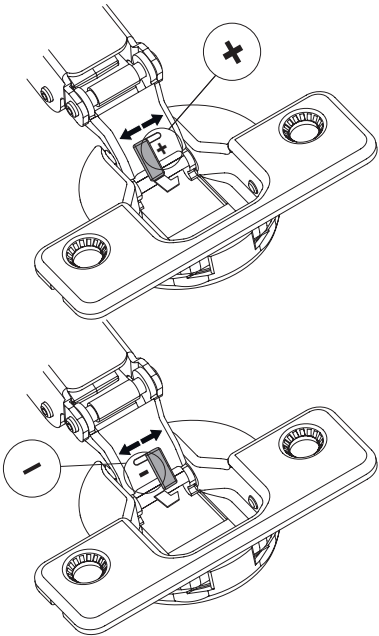
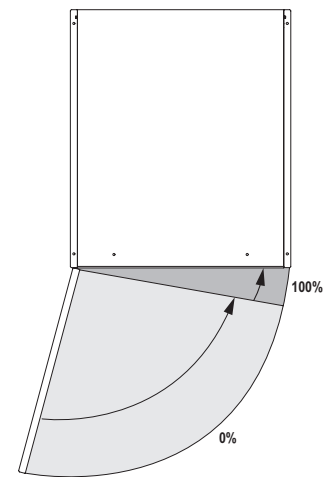
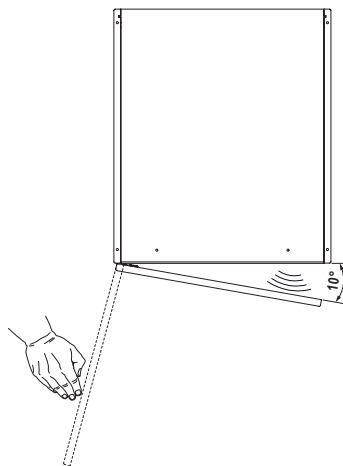
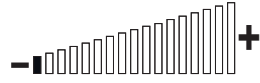
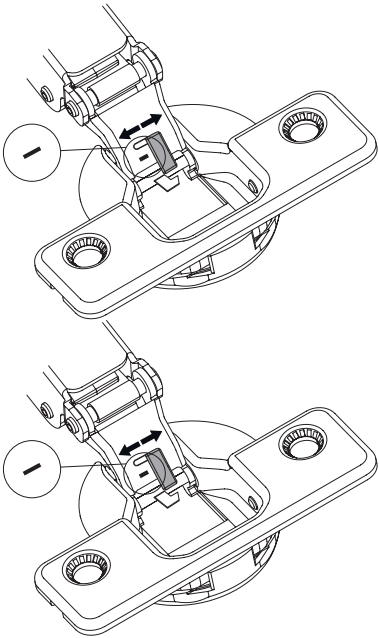
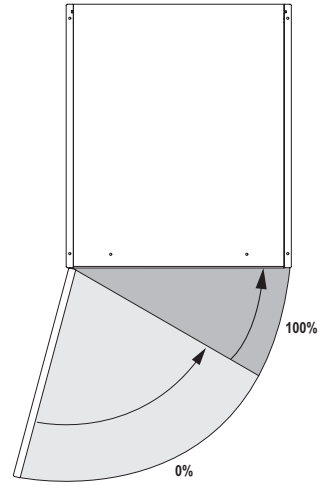
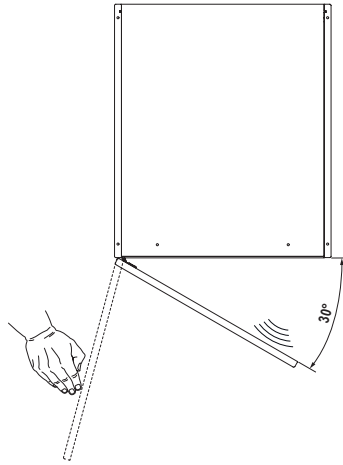
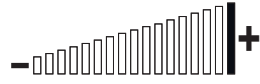
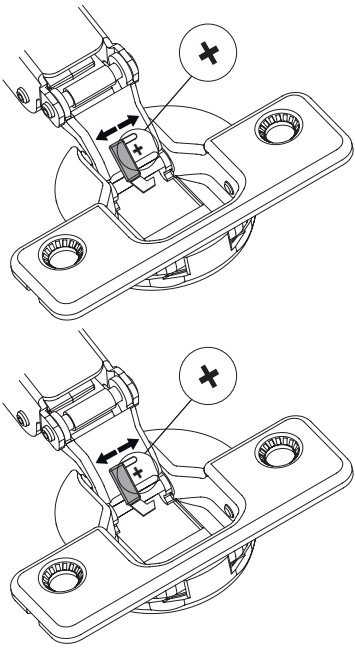

Griffmontage

NL Handvat montage
F Poignée de montage
GB Handle mounting
HR Ručka za montažu
SLO Ravnajte montaža

H Kezelje szerelés
SK Rukoväť montážne
CZ Rukojeť montážní
BG Дръжка за монтиране
RO Măner de montare

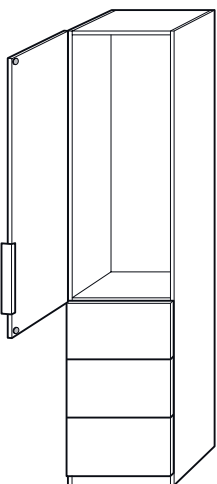
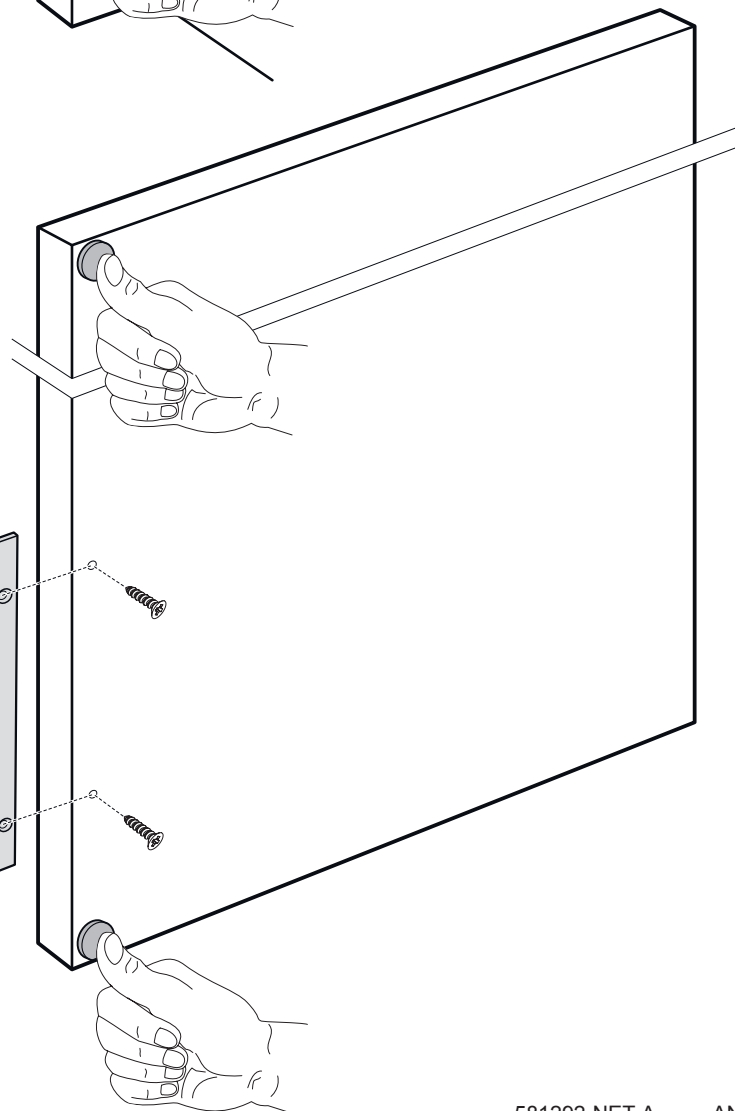
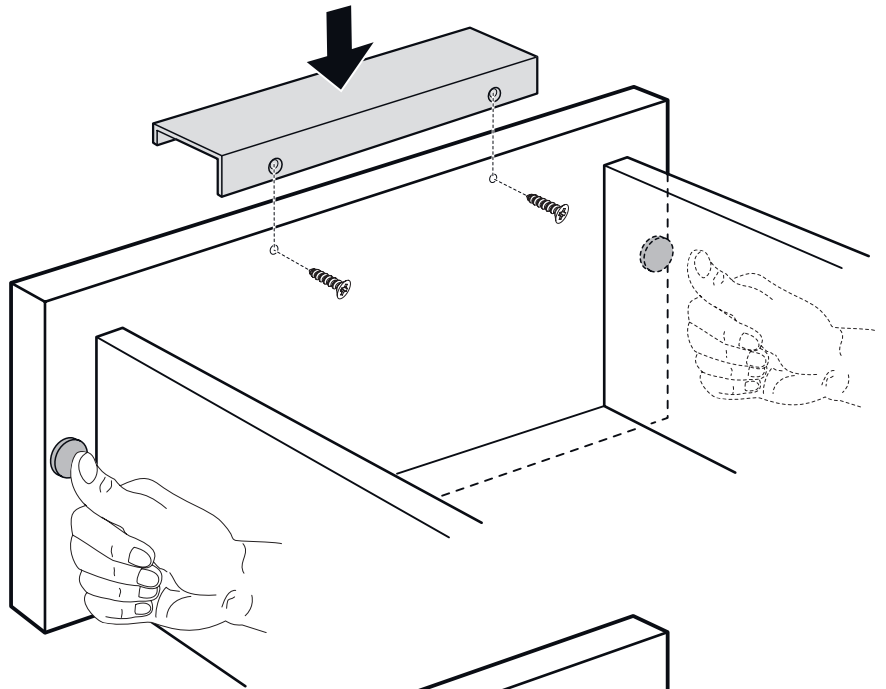
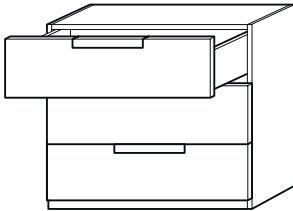
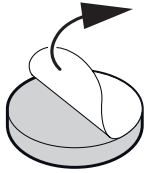
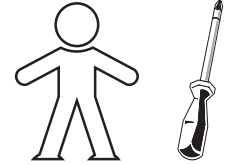
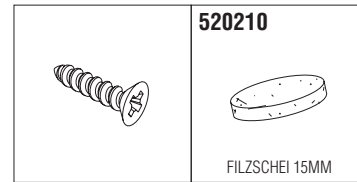

Aufbauanweisung (bitte aufbewahren)

NL Opbouwinstructies (A.u.b. bewaren)

F Consignes d'assemblage (à conserver)

GB Directions for assembly (please save it)

HR Uputa sastavljanja (obavzno sačuvajte)

SLO Navodila za sestavljanje (Skrbno shranite)

H Összeszerelési útmutató (kérjük megőrizni)

SK Návod na montáž (prosím uschovať)

CZ Návod k montáži (uložte si ho prosím)

BG Инструкция за сглобяване (Моля запазете настоящата инструкция)

RO Instrucțiuni de montaj (vă rugăm, păstrați documentul)

Zubehör MONTAGE-SKN-BODENPACKSTÜCK

NL Accessoires

F Accessoires

GB Accessories

HR Pribor

SLO Oprema

H Tartozékok

SK Doplnky

CZ Příslušenství

BG Принадлежности

RO Accesorii

40cm



80cm



50cm



90cm

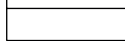

110cm

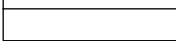

60cm



100cm



120cm

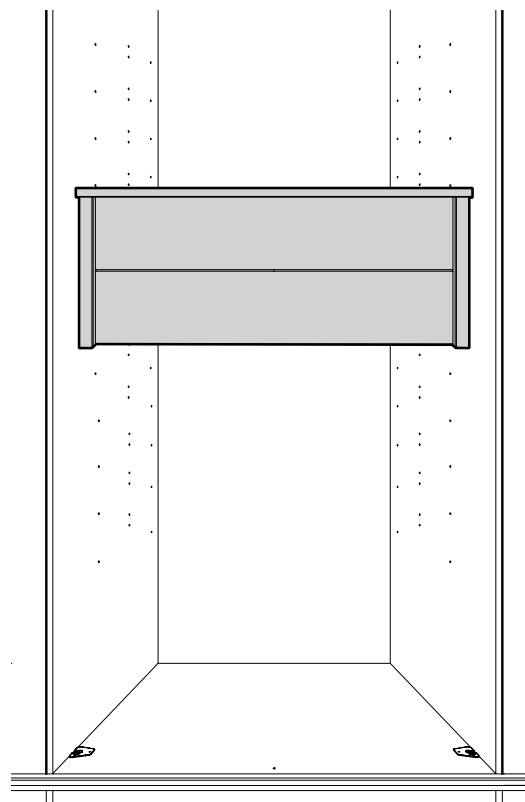
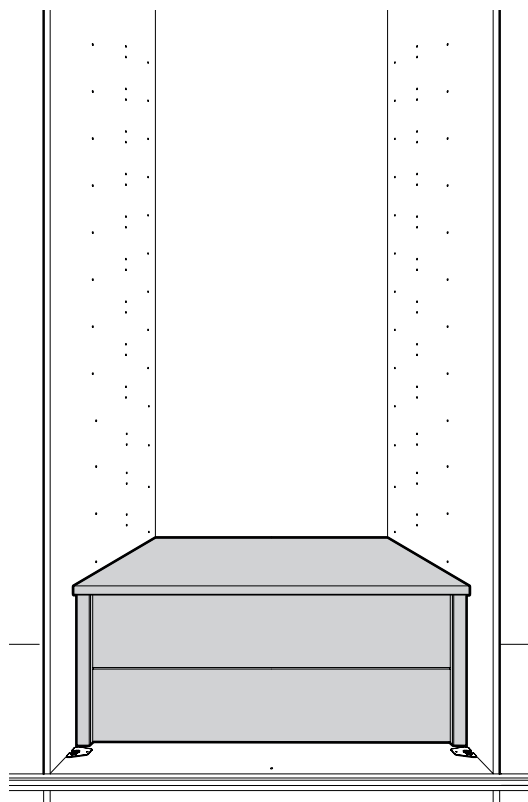

Montage nur durch Fachkräfte für Möbelmontage (FMKU)!

NL Montage alleen door specialisten!
F A ne faire monter que par les équipes spécialisées!
GB To be mounted only by mounting teams!
HR Montaža samo uz pomoć stručne osobe!
SLO Montaža samo s strani strokovnjakov!
H Az összeszerelést csak szakember végezheti!
SK Montáž smú vykonávať iba odborníci!
CZ Montáž smí provádět jen kvalifikovaný personál!
BG Монтажът трябва да се извършва само от специалисти!
RO Efectuarea montajului este permisă exclusiv specialiștilor!

Lesen Sie zuerst die Aufbauanweisung und beginnen Sie dann mit der Montage.

NL Voordat uw met de montage begint, a.u.b. de opbouw instructies lezen
F Avant de commencer avec le montage, nous vous prions de bien lire les consignes d'assemblage.
GB Before starting with the fitting, please read carefully the directions for assembly.
HR Prije montiranja pročitajte uputu za sastavljanje.
SLO Najprej preberite navodila za sestavljanje in šele nato pričnite z montažo.
H Olvassa el először az összeszerelési útmutatót, és csak ezután kezdje el a szerelést.
SK Najskôr si prečítajte návod na montáž a až potom začnite s montážou.
CZ Návod k montáži si nejdříve přečtěte a pak začněte s montáží.
BG Първо прочетете инструкцията заглобяване и след това започнете с монтажа.
RO Mai întâi citiți instrucțiunile de montaj, și numai după aceea începeți montajul.

Bei nicht vorschriftsmäßiger und/oder nicht fachmännischer Montage wird für Personen- oder Sachschäden keinerlei Haftung übernommen.

NL In geval van persoonlijke ongelukken en materiële schade is aansprakelijkheid uitgesloten, indien de montage niet overeenkomstig de voorschriften en/of niet door een vakman werd uitgevoerd.
F Nous déclinons toute responsabilité en cas de dommages corporels ou matériels dus à un montage non conforme aux instructions et/ou exécuté incorrectement.
GB We will not accept any liability in case of personal injury or material damages, if not assembled according to the regulations and/or by specialists.
HR U slučaju nepropisane i/ili ne stručne montaže ne preuzimamo odgovornost za nastanak štete osobama ili stvarima.
SLO Pri montaži brez upoštevanja navodil in/ali pri nestrokovni montaži se ne prevzame nikakršne odgovornosti za telesne poškodbe ali materialno škodo.
H A nem előírás szerint és/vagy nem szakemberrel végzett összeszerelés esetén felmerülő személyi és anyagi károkért semmilyen felelősséget nem vállalunk.
SK V prípade montáže v rozpore s predpismi a/alebo neodbornej montáže nepreberáme v prípade ujmy na zdraví alebo vecných škôd žiadnu záruku.
CZ Při montáži v rozporu s předpisy nebo při neodborné montáži nepřebírá výrobce žádnou záruku za škody vzniklé na osobách nebo předmětech.
BG Ако монтажът не е извършен съгласно инструкцията и/или от специалисти, фирмата не поема отговорност в случай на нараняване на хора или при материални щети.
RO În caz de montaj efectuat necorespunzător și/sau neprofesionist nu ne asumăm niciun fel de responsabilitate pentru vătămarea persoanelor sau pentru pagubele materiale.

Beschlagsübersicht: letzte Seite

NL Beslagoverzicht: laatste pagina GB Fitting survey: last page SLO Seznam sestavnih delov: zadnja stran SK Prehľad kování: posledná strana BG Монтажни елементи: последна страница
F Tableau de quincaillerie: dernière page HR Pregled dijelova: posljednja stranica H Kötőelem áttekintés: utolsó oldal CZ Přehled kování: poslední stránka RO Vedere de ansamblu: ultima pagină

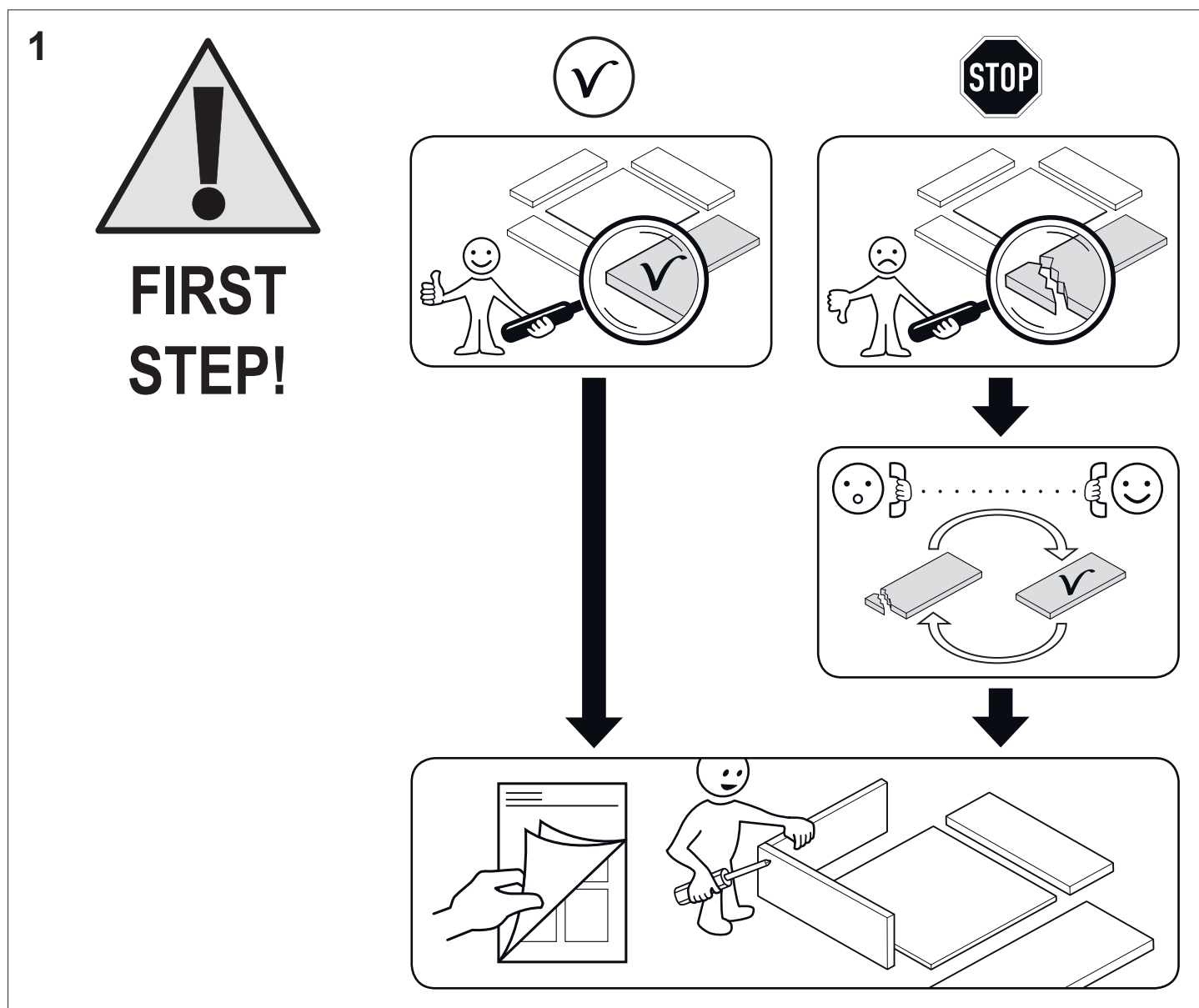

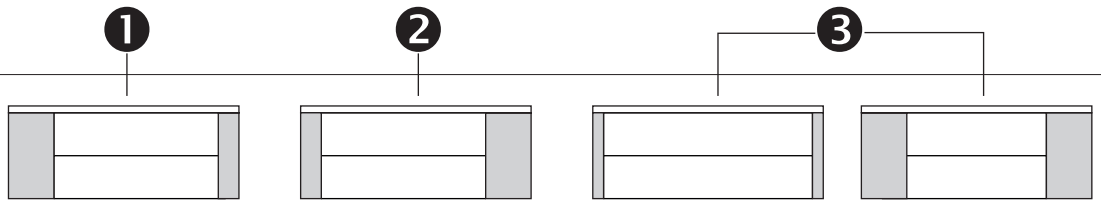

Schwebetürenschränk

- NL Zweefdeurkast
- F Armoire à portes coulissantes
- GB Sliding-door wardrobe
- HR Ormar s kliznim vratima
- SLO Omara z visečimi vrati
- H Tolóajtós szekrény
- SK Skriňa s posuvnými dverami
- CZ Skříň s posuvnými dveřmi
- BG Шкаф с плъзгащи се врати
- RO Dulap cu uși glisante

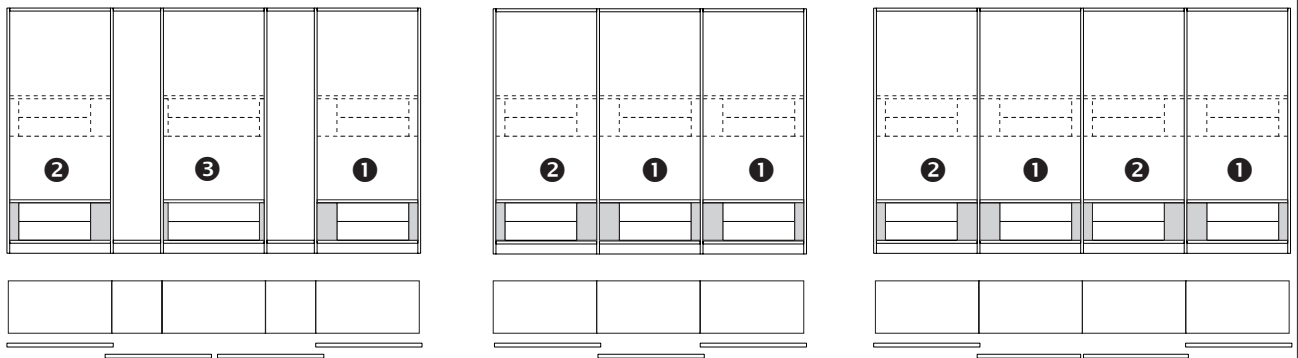
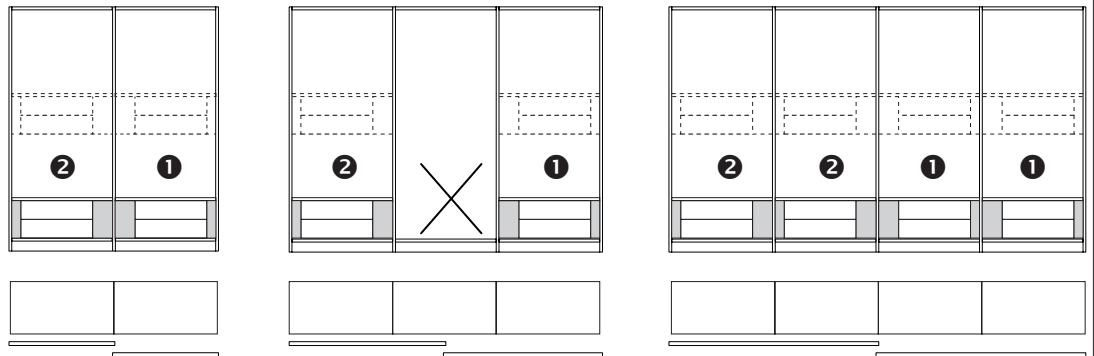

Drehtürenschränk

- NL Draaideurkast
- F Armoire à portes battantes
- GB Hinged-door wardrobe
- HR Ormar s okretnim vratima
- SLO Omara z drsnimi vrati
- H Forgóajtós szekrény
- SK Skriňa s otočnými dverami
- CZ Skříň s otočnými dveřmi
- BG Шкаф с въртящи се врати
- RO Dulap cu uși batante

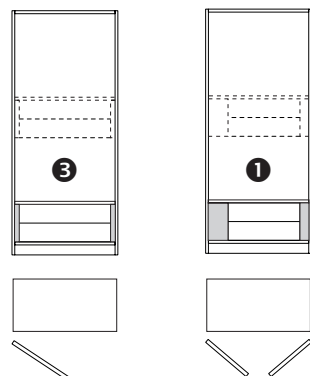

40/50/60

80/90/100/110/120

Falttürschränk

- NL Vouwdeurkast
- F Armoire à portes pliantes
- GB Folding door wardrobe
- HR Ormar s vratima na sklapanje
- SLO Omara z zlozljivimi vrati
- H Spalettaajtós szekrény
- SK Skriňa so skladacími dverami
- CZ Skříň se skládacími dveřmi
- BG Шкаф със сгъваеми врати
- RO Dulap cu uși pliante

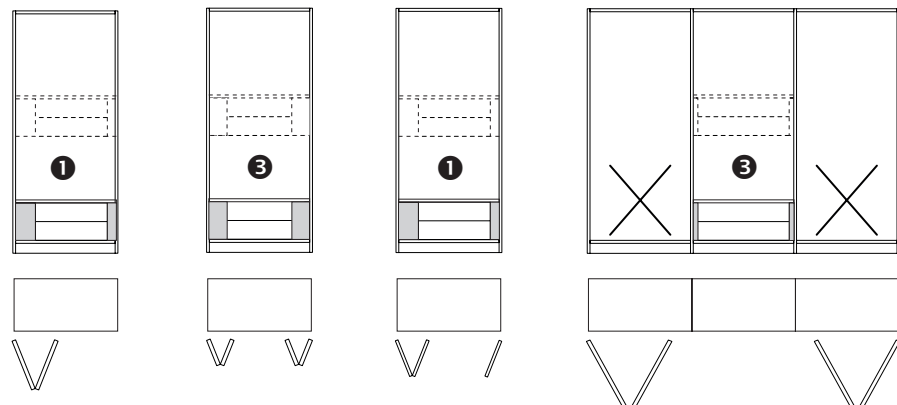

2

Variante 1

NL varianten
F variantes
GB variants
HR varijante
SLO variante
H változatok
SK varianty
CZ varianty
BG варианти
RO variantele

165200

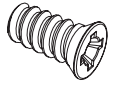

EU6,3*13FLAKO

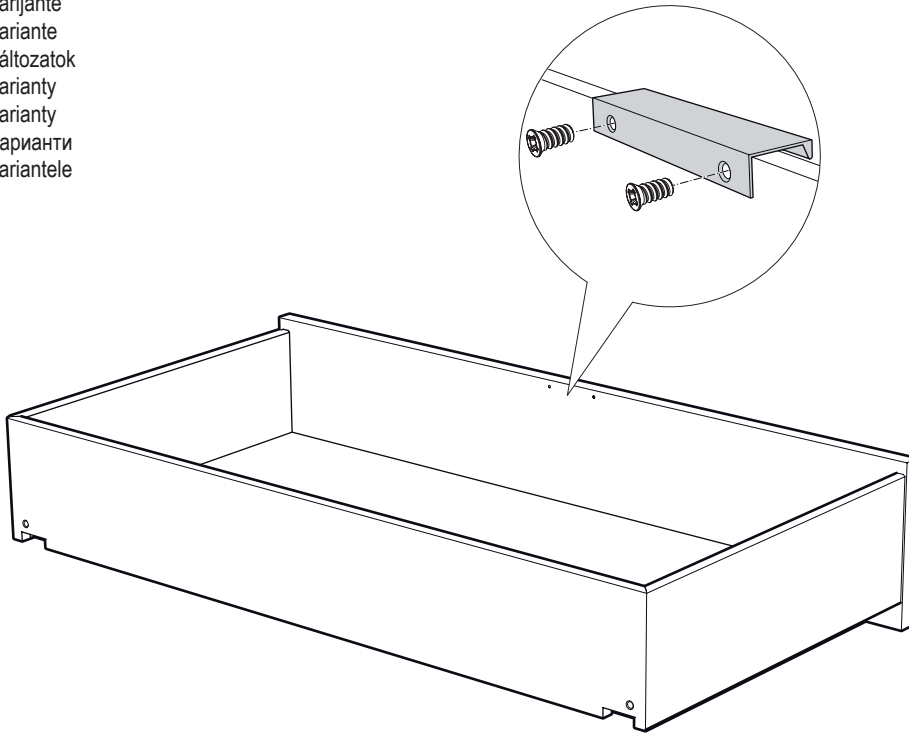

2

Variante 2

NL varianten
F variantes
GB variants
HR varijante
SLO variante
H változatok
SK varianty
CZ varianty
BG варианти
RO variantele

572601

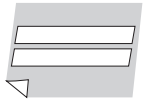

KLEBEB-95x12-2STCK

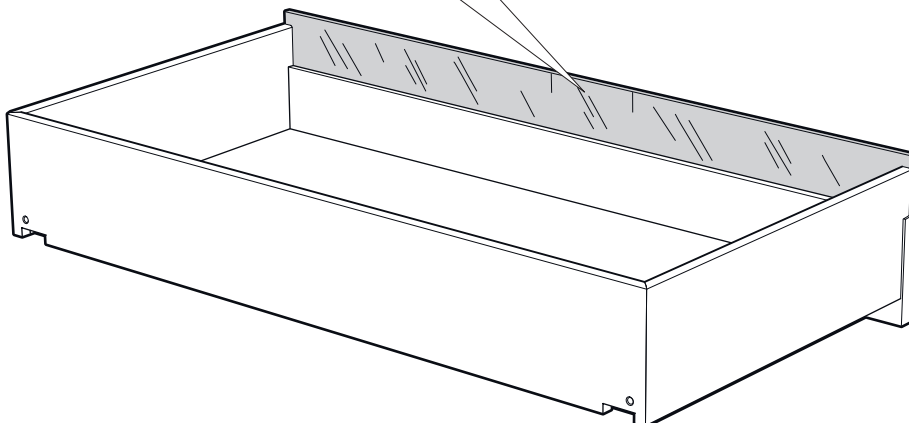
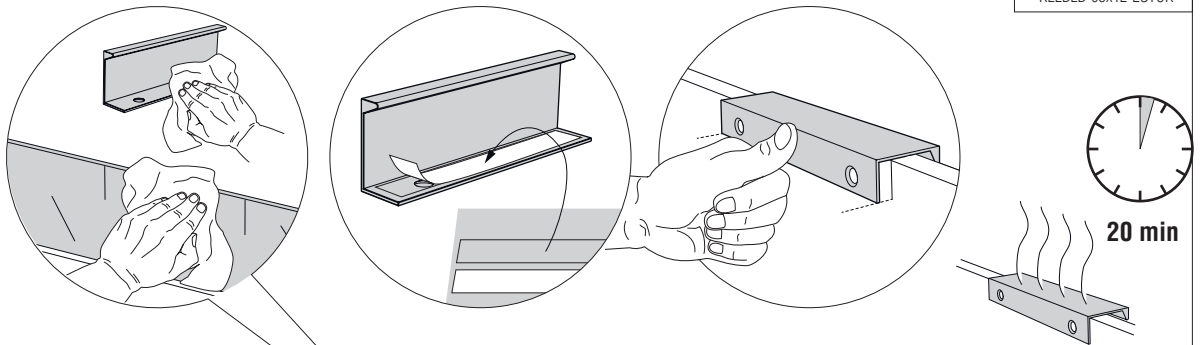

3

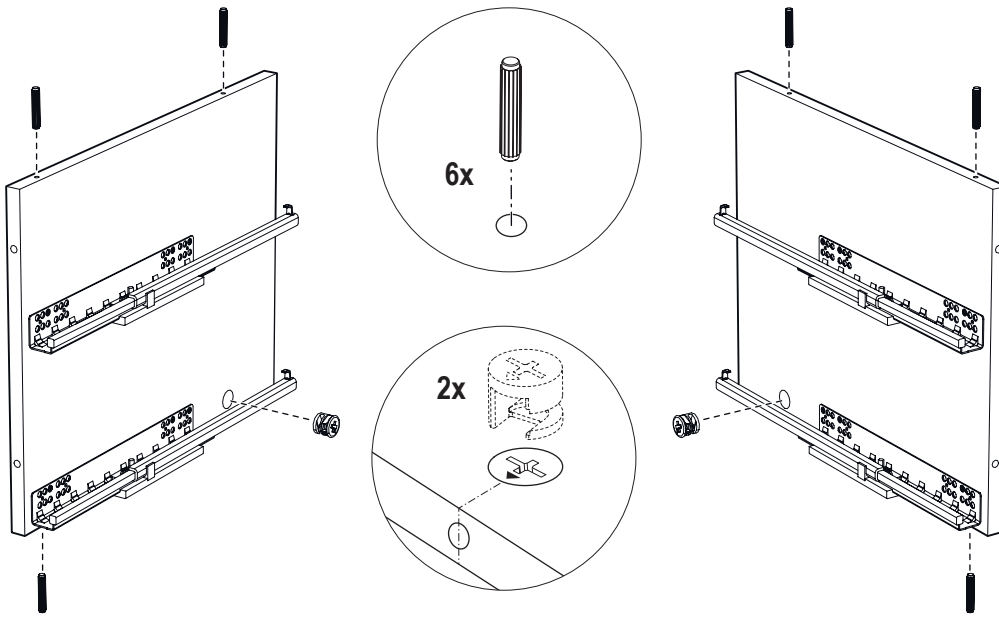

581473

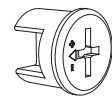

EXC-15MM-RAND

503940



DUEB-05MM

4

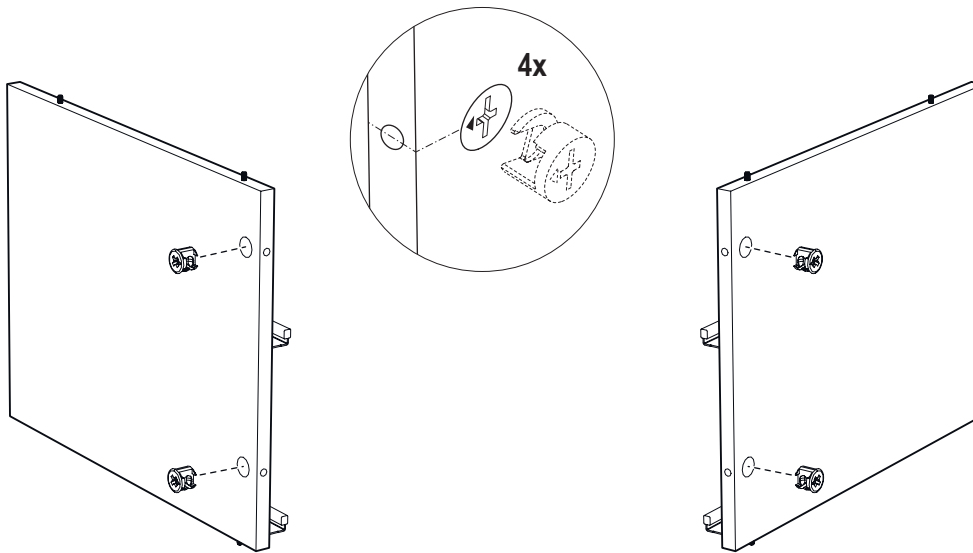

581473

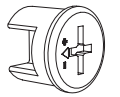

EXC-15MM-RAND

5

575807

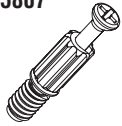

BO-24/7-EU/HÄFELE

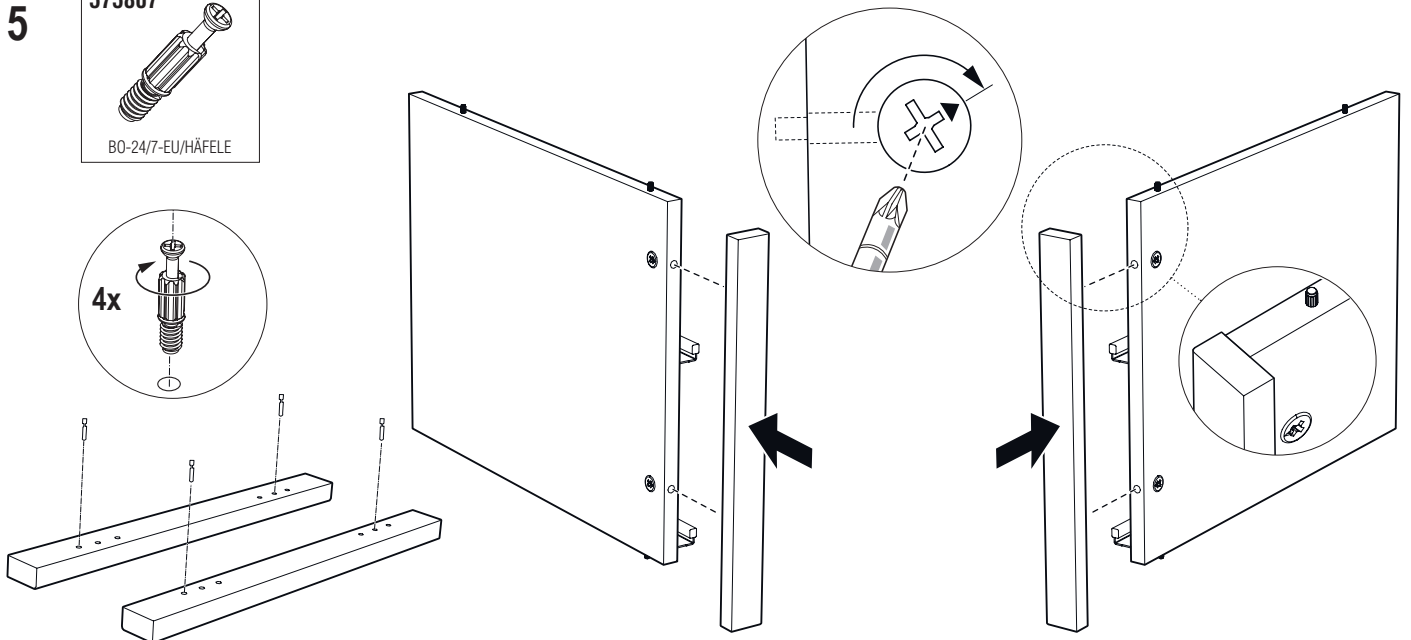

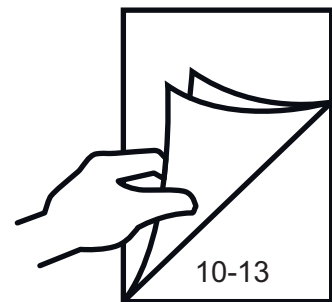
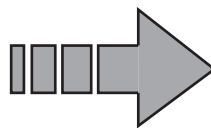
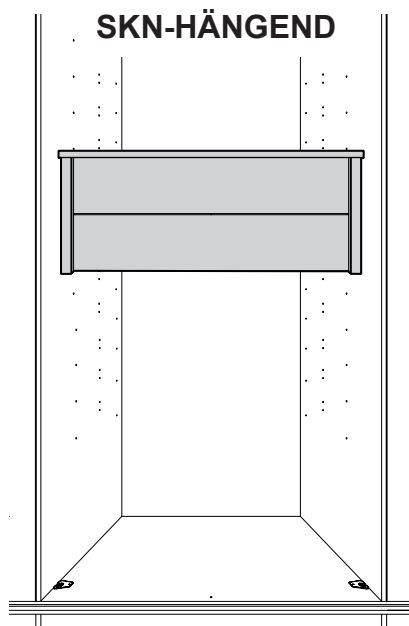
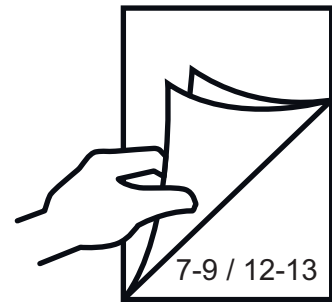
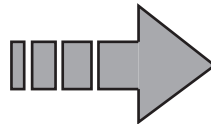
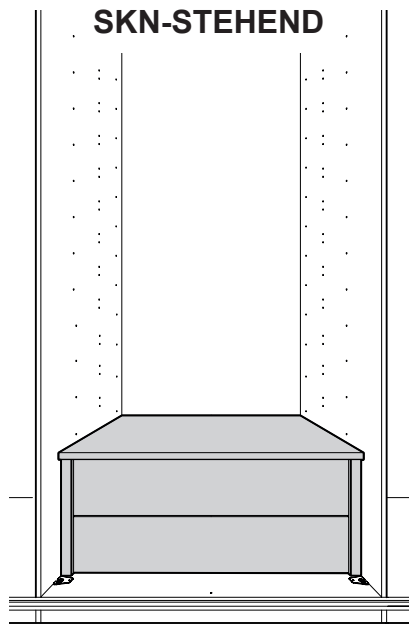

6a

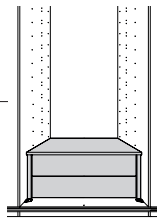
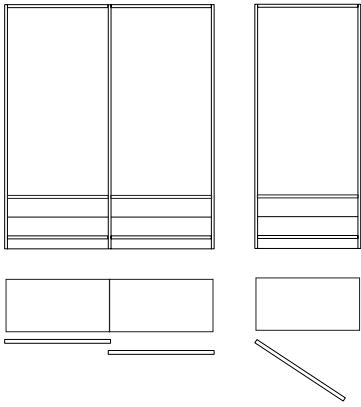

568791

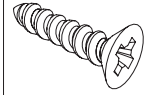

SX4,0°15FLAKO

577797



DISTANZSCH-16/02MM

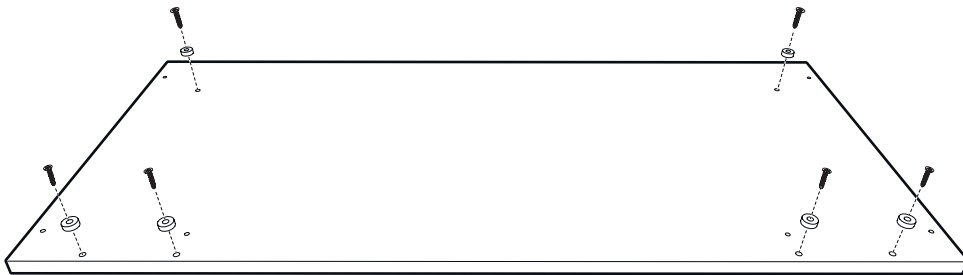
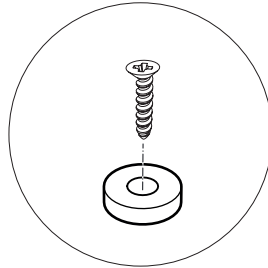

6b

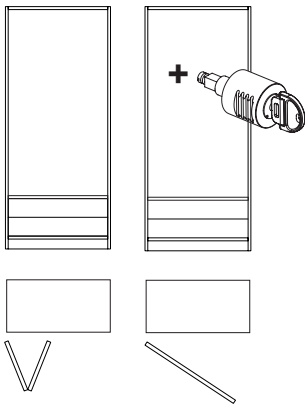

502060

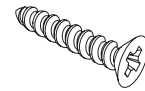

SX4,0°30FLAKO

577796

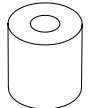

DISTANZSCH-16/18MM

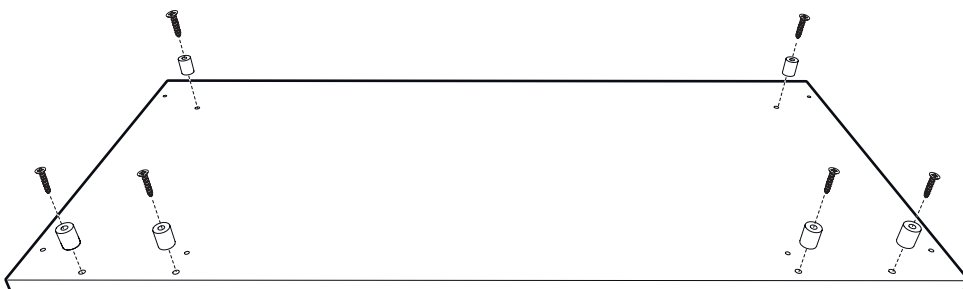
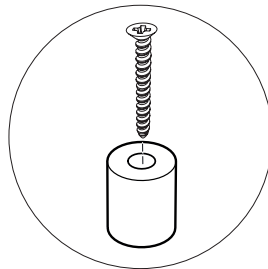

7

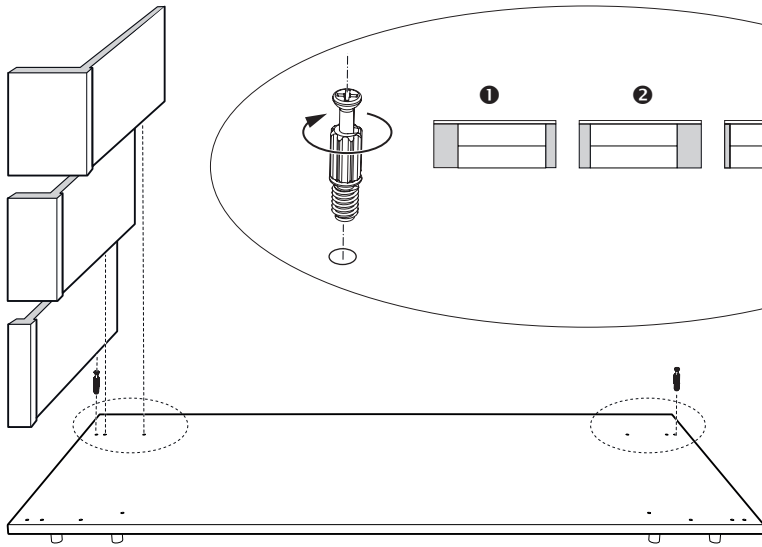
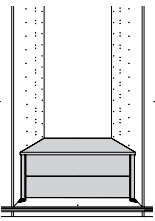

575807

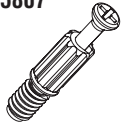

BO-24/7-EU/HÄFELE

8

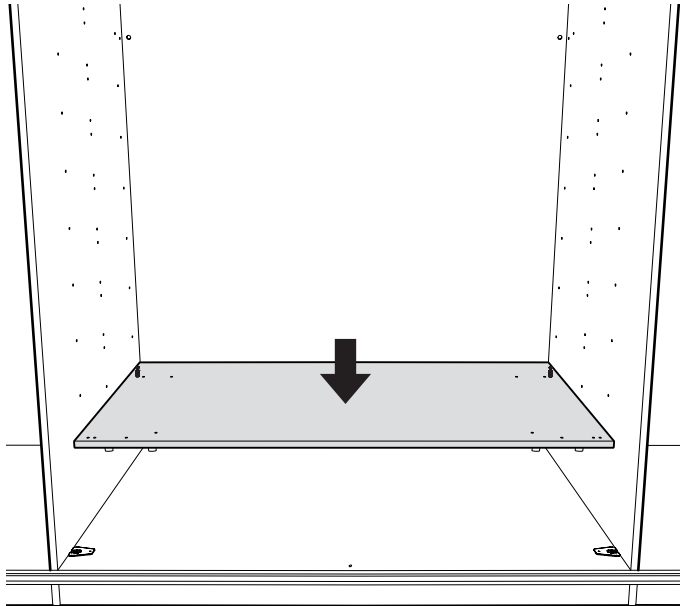

9

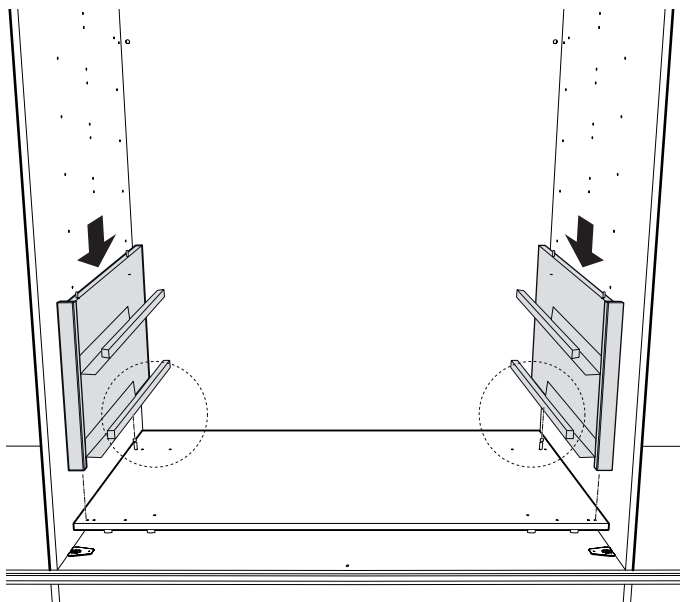

10

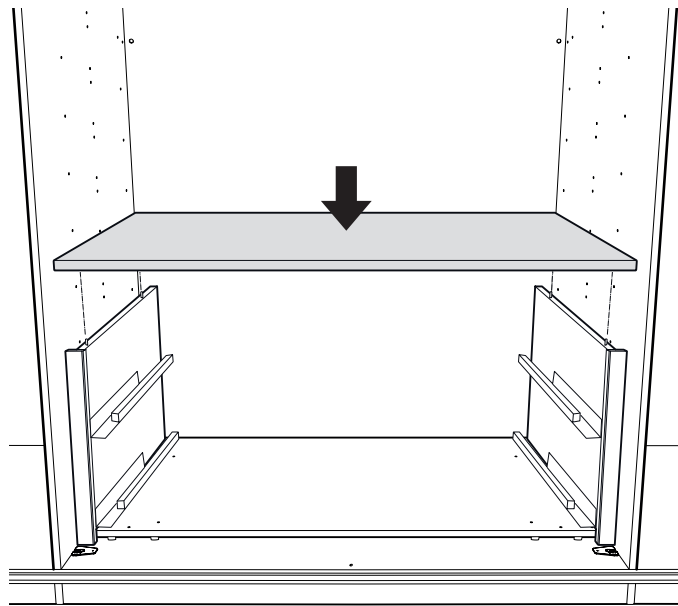
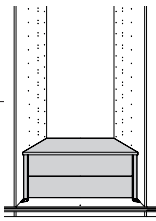

11

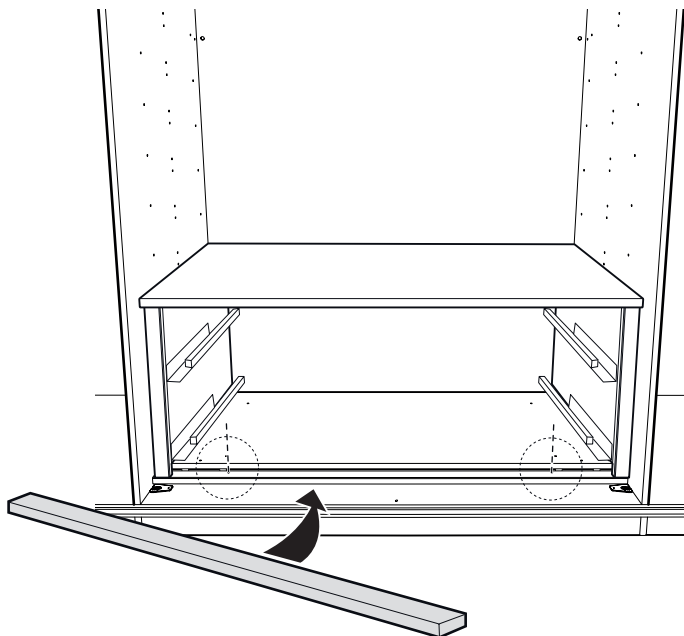
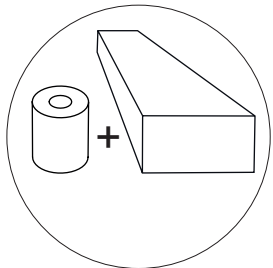
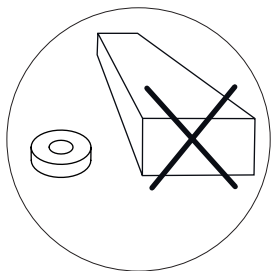

502190

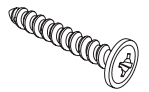

SX4,0*35RW

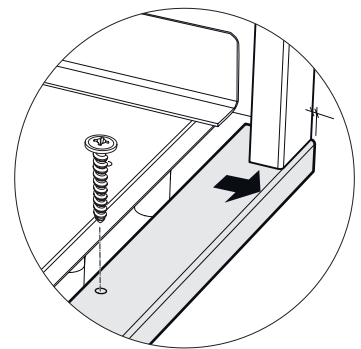

12

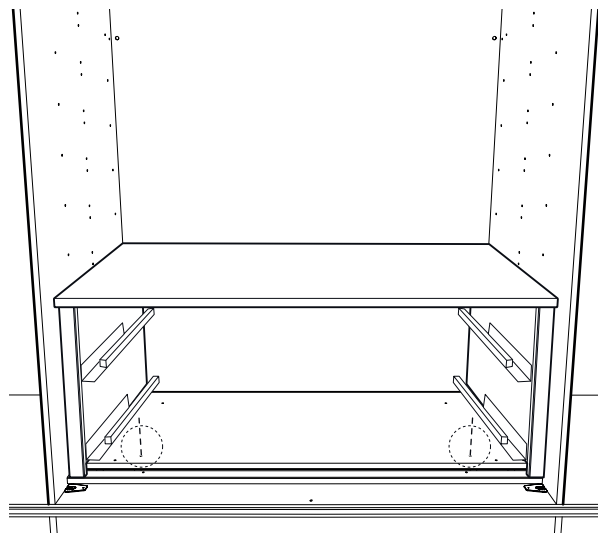

502180



SX 4,0*30 RW

572602



SX-4x50-RW

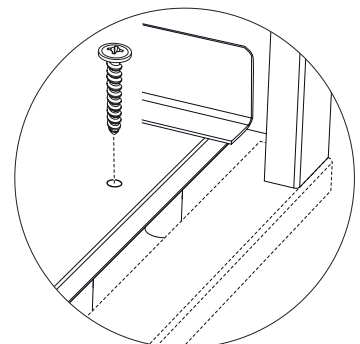

13

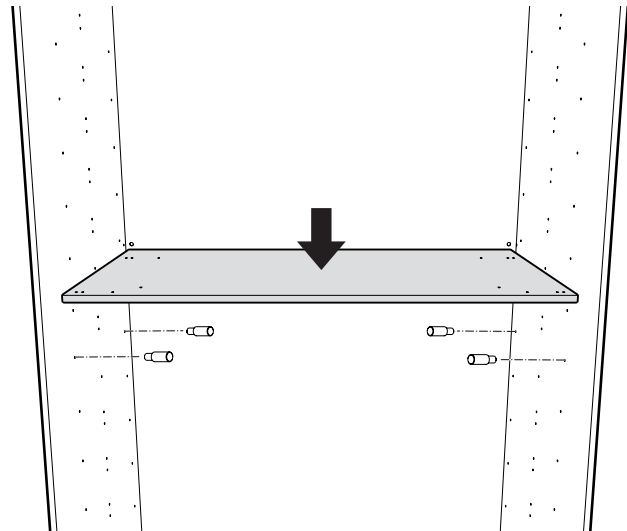
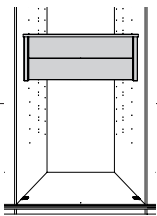

573285



BOTR-7/5MM

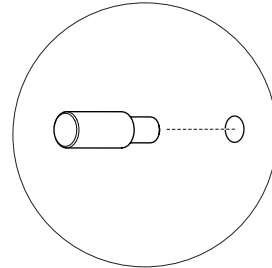

14

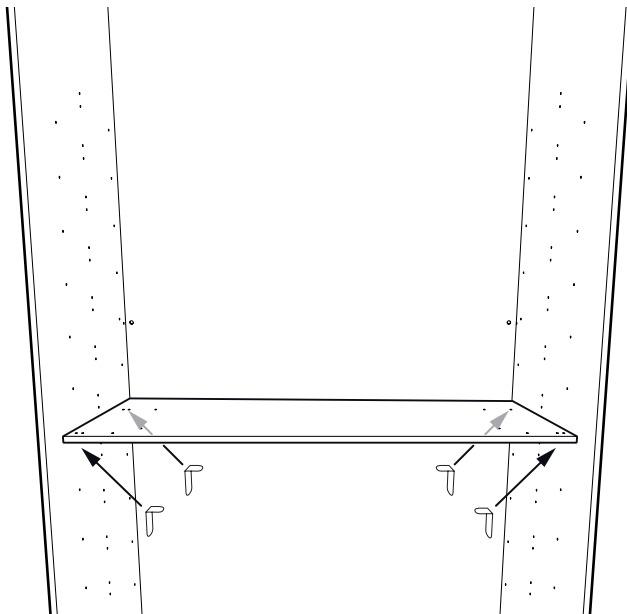

567905

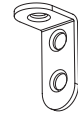

WINKEL-35/16/2

165200

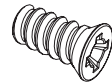

EU6,3*13FLAKO

165150

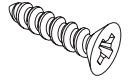

SX3,5*16FLAKO

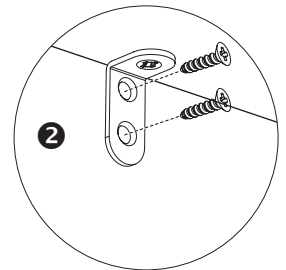
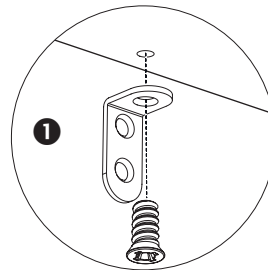

15

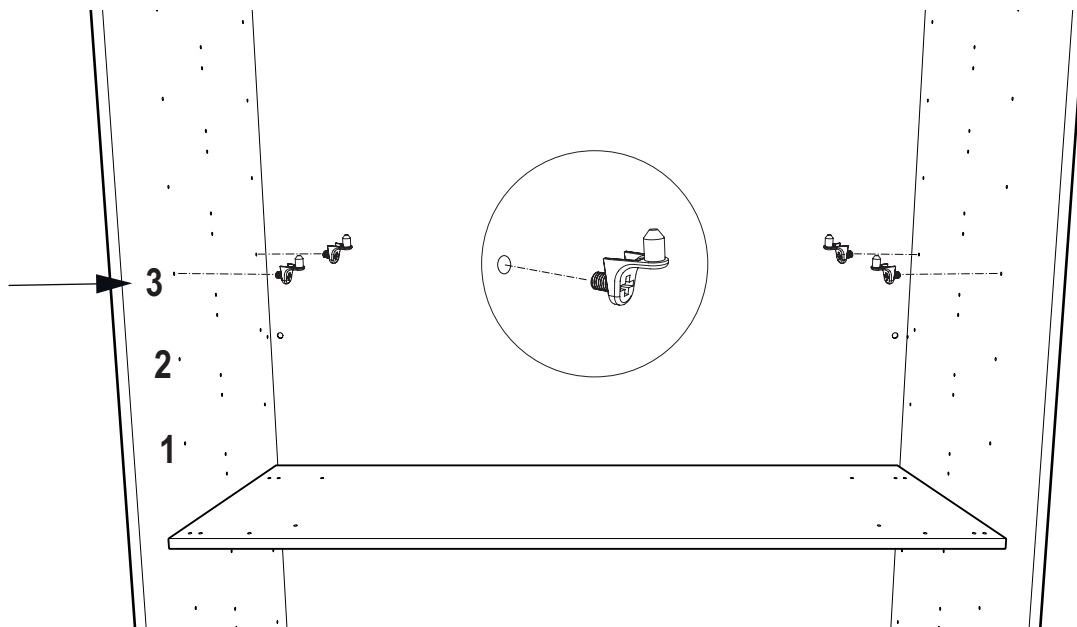

517710



BOTR-STIFT/EU

16

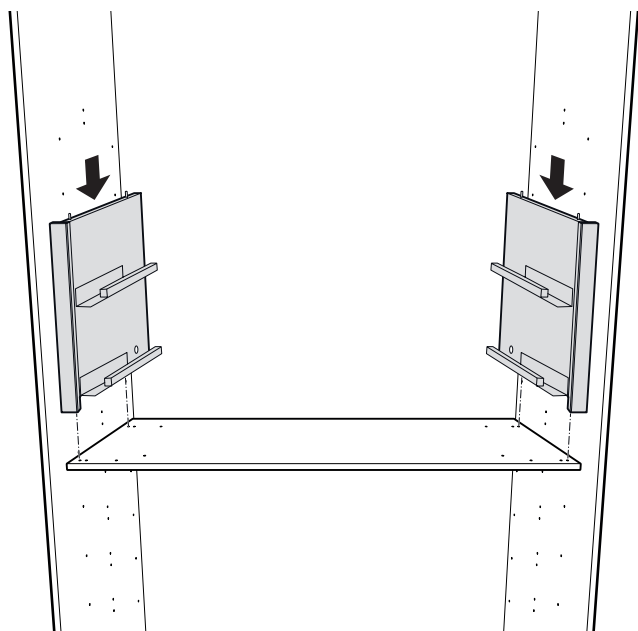
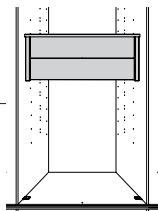

17

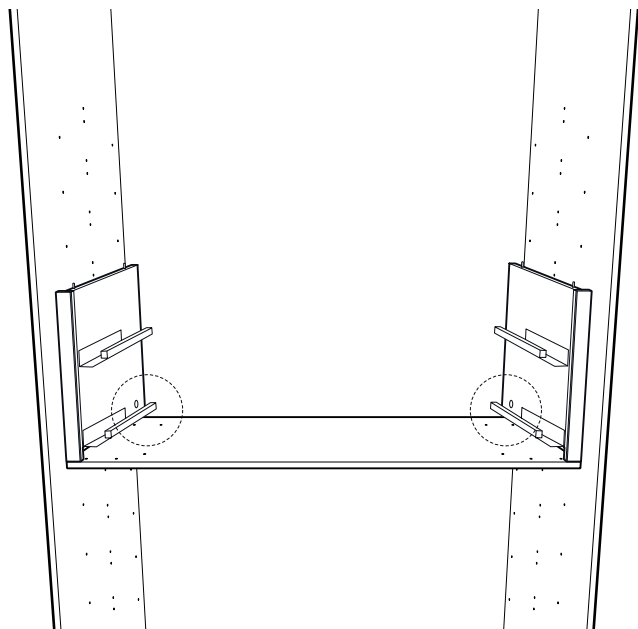

18

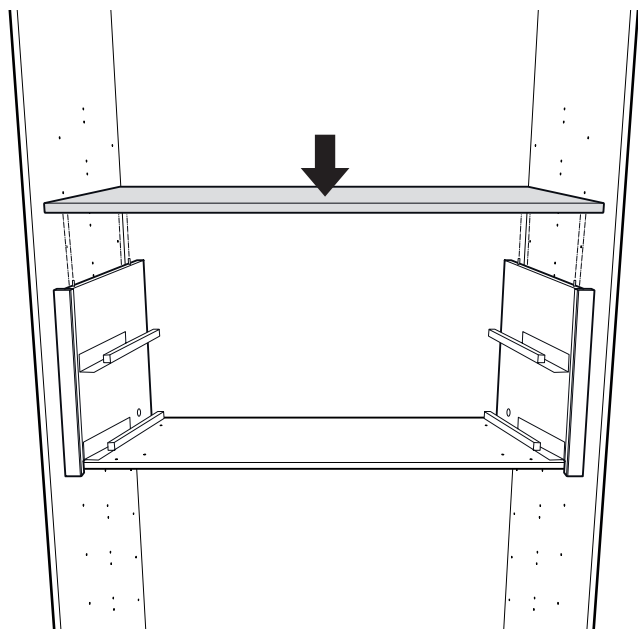

19



Sicherheitsbauteil unbedingt montieren!

- NL Veiligheidsbeslag zeker monteren!
- F Il faut monter la quincaillerie de sécurité!
- GB Please do mount the security fitting!
- HR Obvezno montirati sigurnosni dio!
- SLO Nujno namestiti varnostni sestavni del!
- H A biztonsági alkatrész feltétlenül szerelje fel!
- SK Nezabudnite namontovať bezpečnostný prvok!
- CZ Vždy namontujte bezpečnostní díl!
- BG Задължително монтирайте предпазния детайл!
- RO Montați neapărat elementul de siguranță!

566116

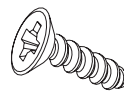

SX4,5*20FLAKO

566115

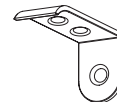

WINKEL-051/25

165150

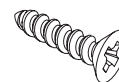

SX3,5*16FLAKO

vorbohren

- NL voorboren
- F pré-percer
- GB predrill
- HR predbušenje
- SLO navrtati
- H előfúrás
- SK predvrtat'
- CZ předvrtat
- BG Предварително пробиване
- RO perforare

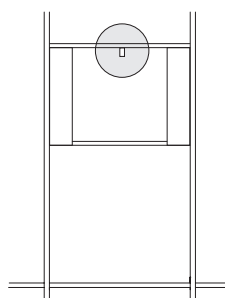
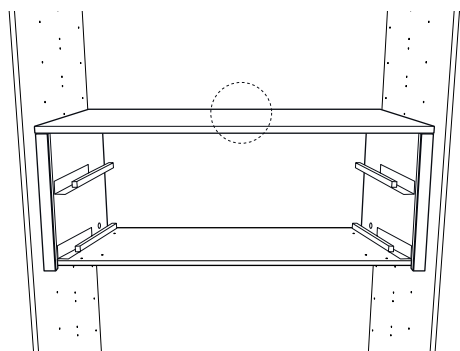
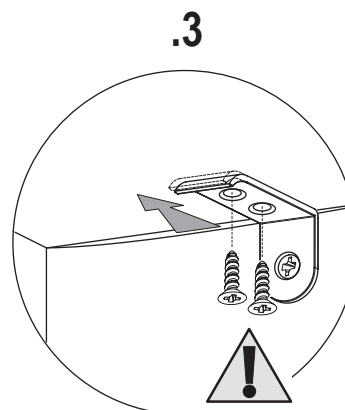
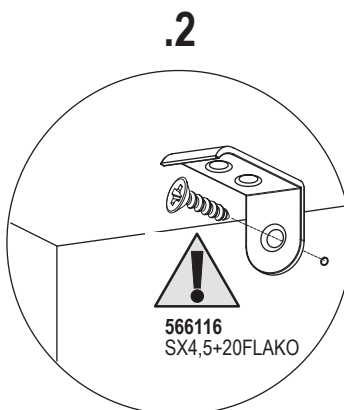
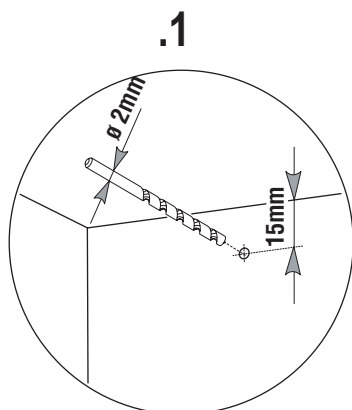

40/50/60

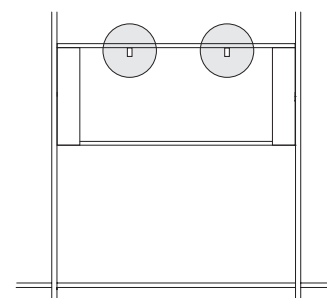

80/90/100/110/120

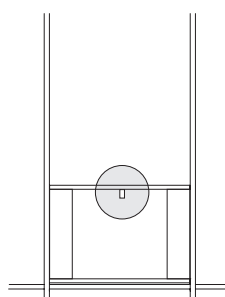
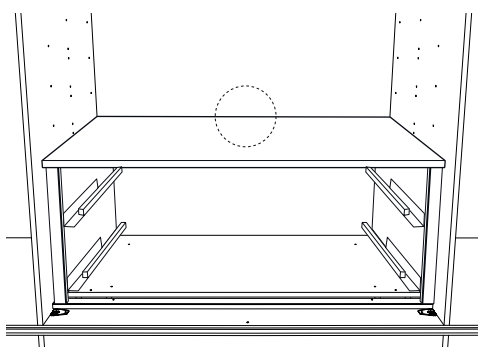

40/50/60

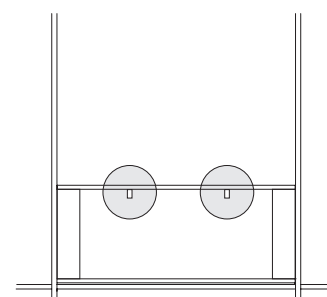

80/90/100/110/120

20

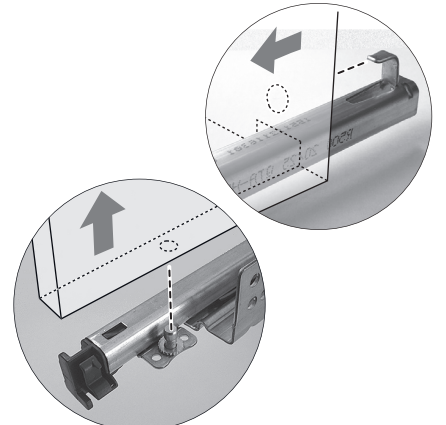
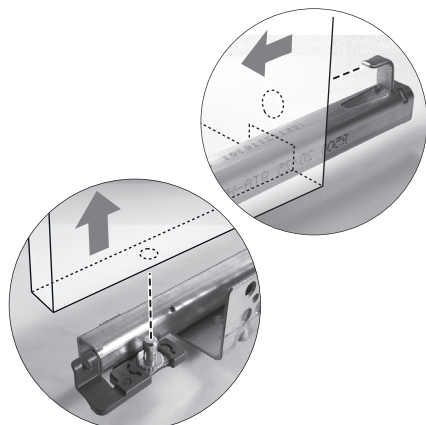
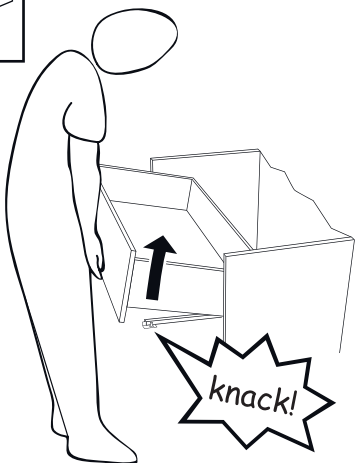
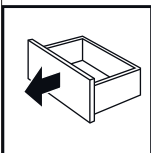
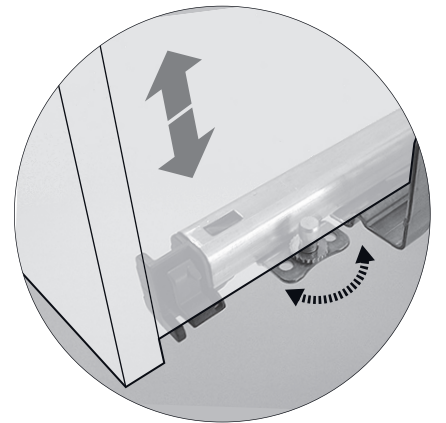
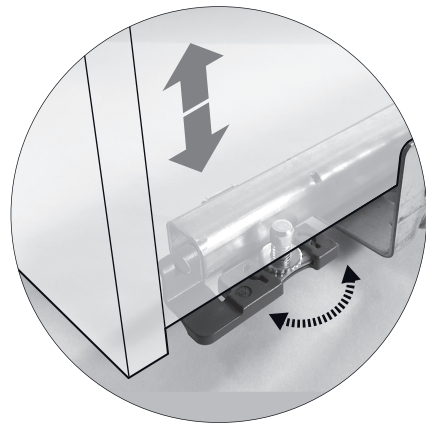
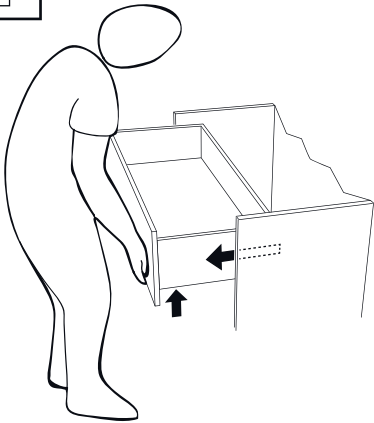
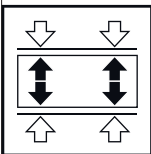
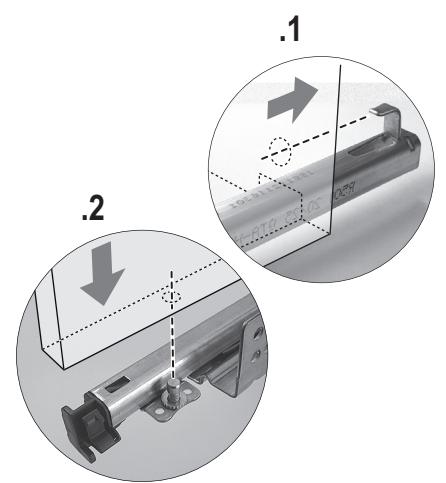
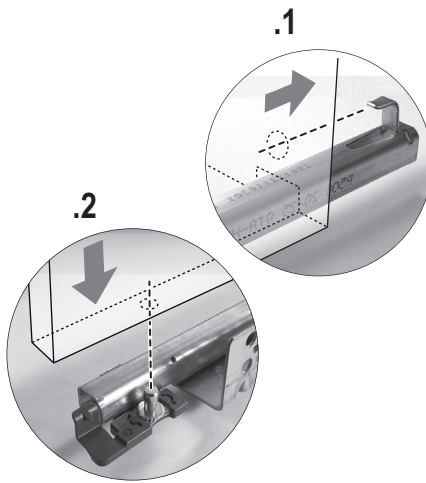
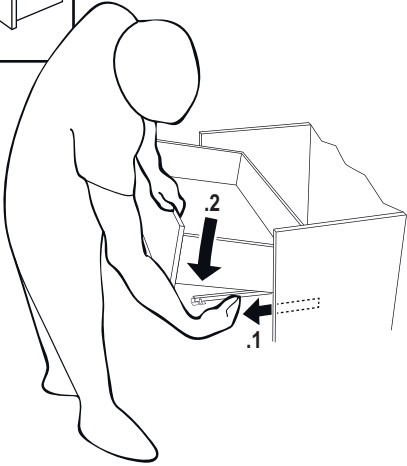
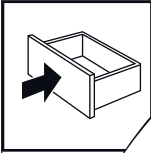
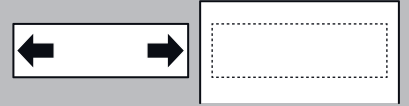
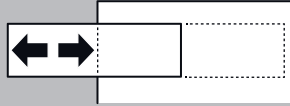

Servicekarte

NL Servicekaart GB Service card SLO Servisna kartica SK Servisná karta BG Сервизна карта
 F Carte de service HR Servisna karta H Szervíz kártya CZ Servisní karta RO Carte de service

Nolte Möbel GmbH&Co.KG, Konrad-Nolte-Straße 20, 76726 Gernersheim, Tel.: 0049-7274/51-120, Fax: 0049-7274/51-12210 www.nolte-moebel.de

Sorgfalt bei der Produktion und der Endkontrolle garantieren mängelfreie Beschaffenheit unserer Produkte. Sollten Sie dennoch Grund zu einer Mängelrüge haben, so senden Sie bitte diese Servicekarte und bei Bedarf die markierte Aufbauanweisung an Ihren Händler.

- NL Zorgvuldigheid bij de productie en de eindcontrole garanderen dat onze producten vrij zijn van gebreken. Indien u toch klachten heeft, stuur dan alsublieft bijgaande servicekaart en zo nodig de montagehandleiding met toelichting naar uw verkoper.
- F Nous veillons soigneusement à la qualité impeccable de nos produits pendant la production et avec le contrôle avant le chargement. Si toutefois, vous êtes amenés à nous adresser une réclamation, nous vous prions de nous joindre la carte de service et la notice de montage sur lesquelles vous aurez marqué la pièce en question.
- GB Our production techniques and final quality inspections ensure that our products are faultlessly manufactured. However, if you should have any reason for complaint, please send the service card to your dealer, if necessary enclosing the assembly instructions to indicate the faulty part.
- HR Pozornost pri likom proizvodnje i finalne kontrole jamče bespriekorno stanje naših proizvoda. Imate li ipak osnova za reklamaciju, molimo da tada pošaljete priloženu servisnu kartu i prema potrebi označeno uputstvo za sklapanje vašem trgovcu.
- SLO Skbnost pri izdelavi in zaključni kontroli zagotavlja izdelavo naših produktov brez napak. V primeru, da imate razlog za pritožbo, Vas prosimo da svojemu trgovcu pošljete pritrjeno servisno kartico in po potrebi tudi označeno navodilo glede sestavljanja.
- H A gondosság a gyártás és a végső ellenőrzés során garantálja termékeink hibátlan minőségét. Ha Önnek ennek elnére is oka lenne az áru kellekhiányának bejelentésére, úgy kérem küldje el a mellékelt szervizkártyát és szükség esetén a megjelölt összeszerelési útmutatót kereskedőjének.
- SK Dôslednosť pri výrobe a výstupnej kontrole je zárukou bezchybných vlastností našich výrobkov. Ak však aj napriek tomu máte dôvod na reklamáciu, zašlite priloženú servisnú kartu a v prípade potreby označený návod na montáž svojmu predajcovi.
- CZ Pečlivost během výroby a výstupní kontrola zaručují technicky bezvadné vlastnosti našich produktů. Pokud byste přesto měli důvod k reklamaci, zašlete svému obchodníkovi přiloženou servisní kartu a v případě potřeby také označený návod k montáži.
- BG Прецизността при производството и при крайния контрол гарантират отличното качество на нашите продукти. Ако въпреки това имате основание за reklamacия, моля изпратете на Вашия продавач приложената сервизна карта, а при нужда - маркираната инструкция за сглобяване.
- RO Atenția în timpul producției și la verificarea finală garantează calitatea impecabilă a produselor noastre. Dacă totuși aveți motive de reclamație din cauza unor deficiențe de calitate, trimiteți distribuitorului dumneavoastră cartea de service atașată și - dacă este nevoie - instrucțiunea de montaj marcată.

Zubehör MONTAGE-SKN-BODENPACKSTÜCK

Typ

NL Type GB Type SLO Tip SK Typ
 BG Вид F Type HR Tip H Tipus CZ Typ RO Tip

Datum

NL Date GB Date SLO Datum SK Dátum
 BG Дата F Date HR Datum H Dátum CZ Datum RO Data

Kaufvertragsnummer / Lieferscheinnummer

Fehlerursache







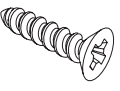

- NL Koopcontract nr. / vervoerdocument nr.
 F No. contrat d'achat / no. bon de livraison
 GB Purchase contract no. / delivery note no.
 HR Broj prodajnog ugovora / Broj otpравnice
 SLO Številka kupoprodajne pogodbe / Številka dostavnice
 H Numărul contractului de achiziționare / numărul bonului de livrare
 SK Vételi szerződés száma / Szállítólevél száma
 CZ Číslo kúpnjej zmluvy / číslo dodacieho listu
 BG № на договора за продажба / № на деливъри ордера
 RO C.kupní smlouvy / číslo dodacieho listu

- NL Oorzaak van het gebrek H Hiba oka
 F Raison de la réclamation SK Příklad chyby
 GB Reason for complaint CZ Příčina závady
 HR Uzrok greške BG Причина за дефекта
 SLO Vzrok napake RO Cauza defectiunilor

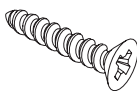

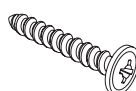
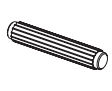
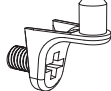
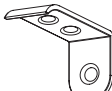
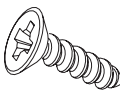
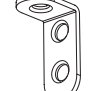
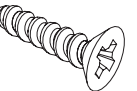
Beschlagsübersicht

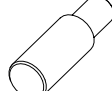
NL Beslagoverzicht GB Fitting survey SLO Seznam sestavnih delov SK Prehľad kovani BG Монтажни елементи
 F Tableau de quincaillerie HR Pregled dijelova H Kötőelem áttekintés CZ Přehled kování RO Vedere de ansamblu

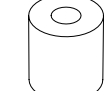
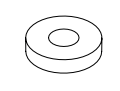
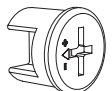
165150  SX3,5*16FLAKO	165200  EU6,3*13FLAKO	502060  SX4,0*30FLAKO	502180  SX 4,0*30 RW	502190  SX4,0*35RW	503940  DUEB-05MM	517710  BOTR-STIFT/EU	566115  WINKEL-051/25
566116  SX4,5*20FLAKO	567905  WINKEL-35/16/2	568791  SX4,0*15FLAKO	572601  KLEBEB-95x12-2STCK	572602  SX-4x50-RW	573285  BOTR-7/5MM	575807  BO-24/7-EU/HÄFELE	577796  DISTANZSCH-16/18MM
577797  DISTANZSCH-16/02MM	581473  EXC-15MM-RAND						

Aufbauanweisung

(Bitte aufbewahren)

Opbouw instructies (A.u.b. bewaren)
Consignes d'assemblage (A conserver)
Directions for assembly (Please save it)

NL Kast inzet

F Aménagement intérieur

GB Gents fitments

Schrankeinsatz

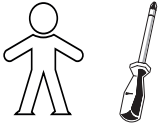

Montage nur durch Fachkräfte!

NL Montage alleen door specialisten!
F A ne faire monter que par les équipes spécialisées!
GB To be mounted only by mounting teams!

Bei nicht vorschriftsmäßiger und/oder nicht fachmännischer Montage wird bei Personen- oder Sachschäden keinerlei Haftung übernommen.

NL In geval van persoonlijke ongelukken en materiële schade is aansprakelijkheid uitgesloten, indien de montage niet overeenkomstig de voorschriften en/of niet door een vakman werd uitgevoerd.

F Nous déclinons toute responsabilité en cas de dommages corporels ou matériels dus à un montage non conforme aux instructions et/ou exécuté incorrectement.

GB We will not accept any liability in case of personal injury or material damages, if not assembled according to the regulations and/or by specialists.

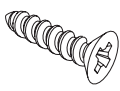
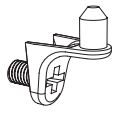
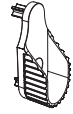
165150  SX3,5*16FLAKO	517710  BOTR-STIFT/EU	518710  SCHRLA-METALL					
--	---	---	--	--	--	--	--

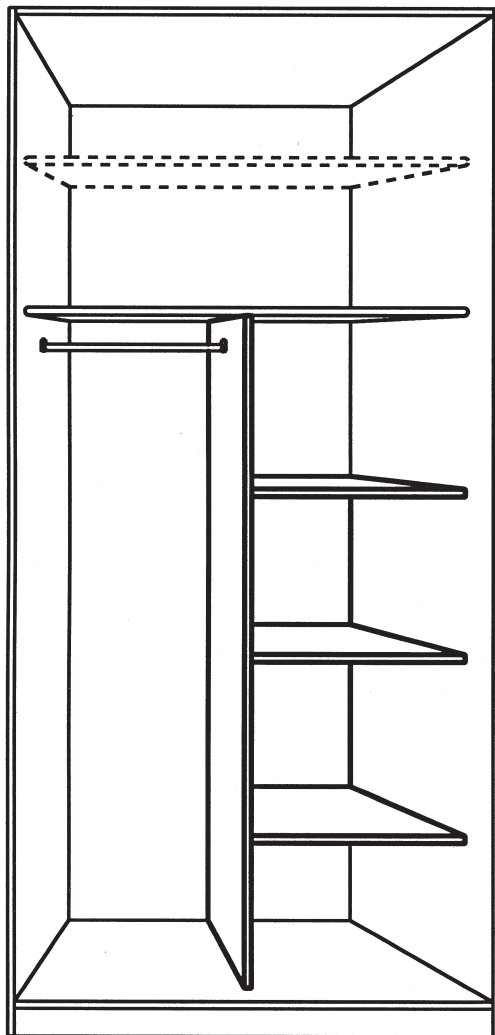

SRE

Zubehör optional

NL Accessoires facultatief
F Accessoires optionnel
GB Accessories optional
HR Pribor izborni
SLO Oprema neobvezno
H Tartozékok választható
SK Doplnky voliteľný
CZ Příslušenství volitelný
BG Принадлежности по избор
RO Accesorii facultativ

1

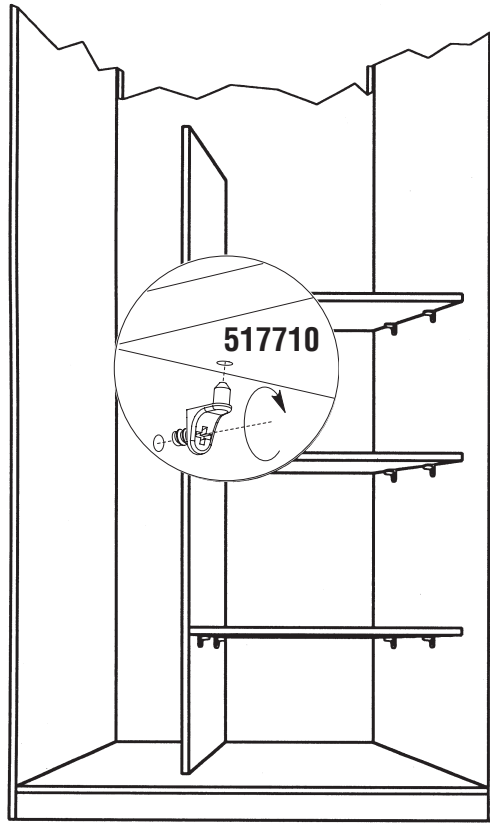

2

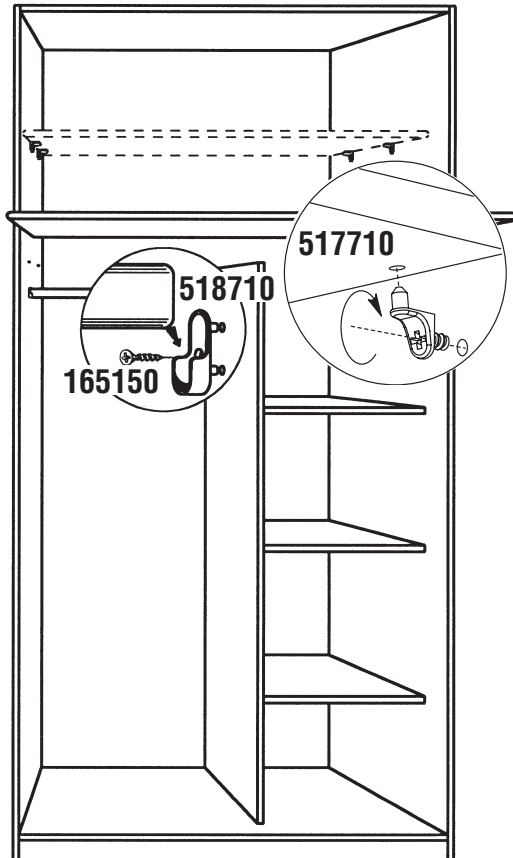

Aufbauanweisung

(Bitte aufbewahren)

Opbouw instructies (A.u.b. bewaren)
Consignes d'assemblage (A conserver)
Directions for assembly (Please save it)

NL Accessoires

F Accessoires

GB Accessories

Zubehör



Montage nur durch Fachkräfte!

- NL Montage alleen door specialisten !
- F A ne faire monter que par les équipes spécialisées !
- GB To be mounted only by mounting teams !

Bei nicht vorschriftsmäßiger und/oder nicht fachmännischer Montage wird bei Personen- oder Sachschäden keinerlei Haftung übernommen.

NL In geval van persoonlijke ongelukken en materiële schade is aansprakelijkheid uitgesloten, indien de montage niet overeenkomstig de voorschriften en/of niet door een vakman werd uitgevoerd.

F Nous déclinons toute responsabilité en cas de dommages corporels ou matériels dus à un montage non conforme aux instructions et/ou exécuté incorrectement.

GB We will not accept any liability in case of personal injury or material damages, if not assembled according to the regulations and/or by specialists.

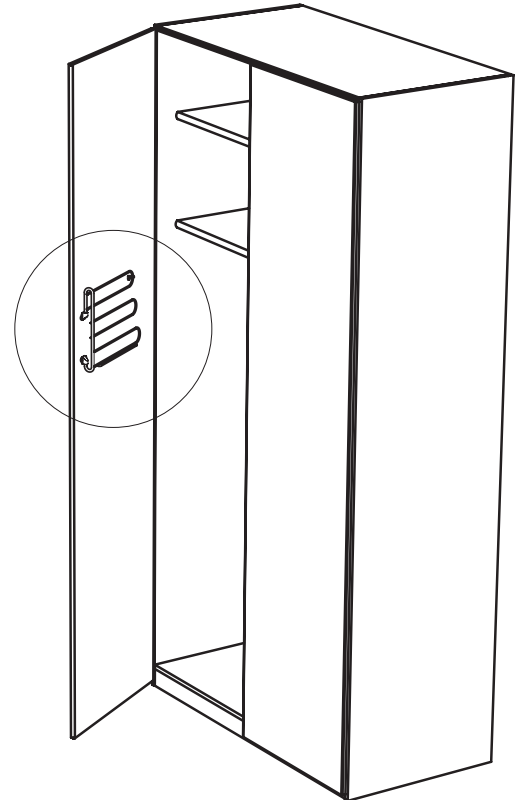
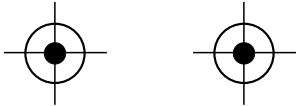

Krawatten- und Gürtelhalter KGH

- NL Stropdas- en ceintuurhouder KGH
- F Porte- cravates et ceintures KGH
- GB Tie and belt rack KGH

Tür links

- NL deur links
- F porte à gauche
- GB door left hand

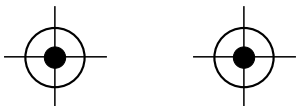

1

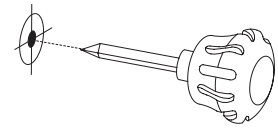
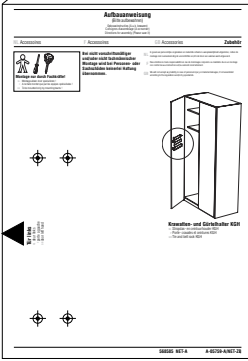
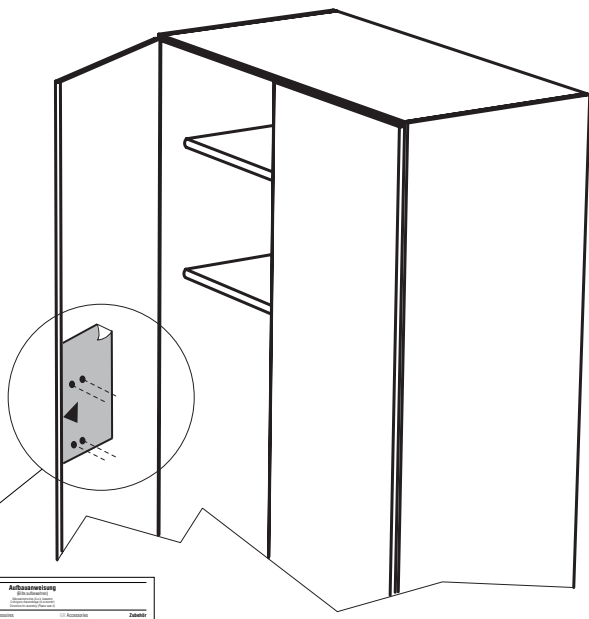

Ankörden an den markierten Stellen
 Boorpunt aanstippen
 Faire une marque à l'endroit indiqué
 Mark the place to be drilled

2

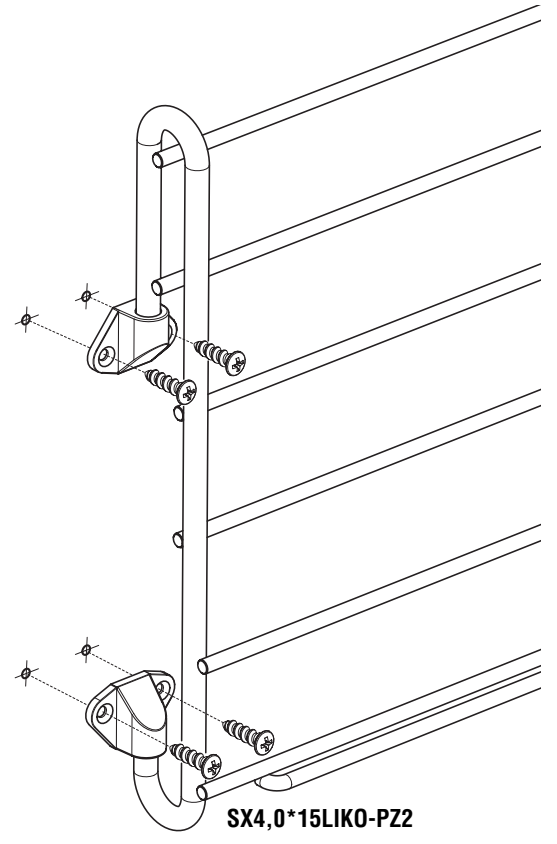

SX4,0*15LIKO-PZ2

3

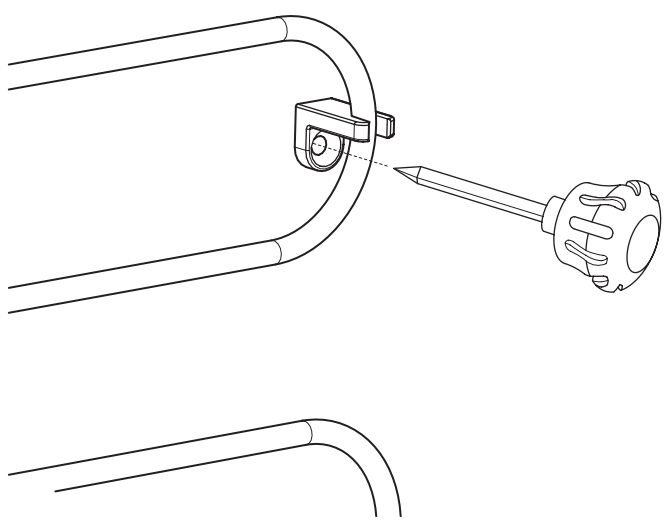

4

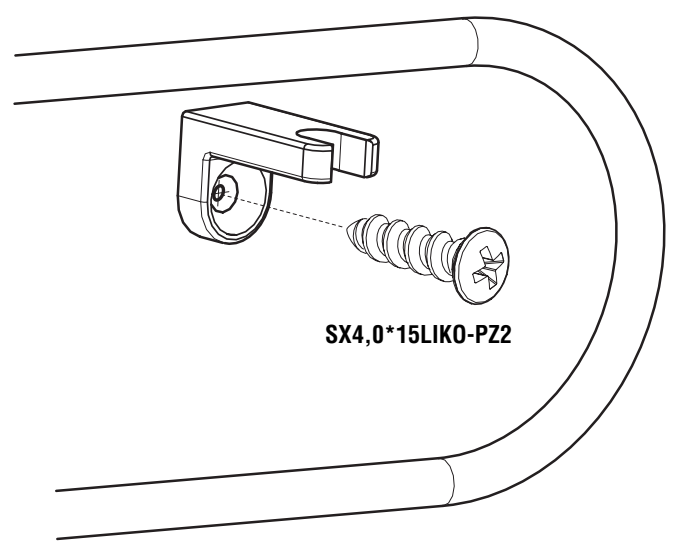

SX4,0*15LIKO-PZ2