

LINCOLN

5S MC LN 56

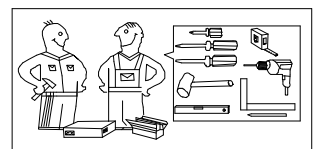

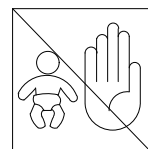

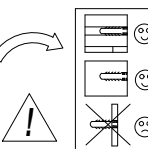
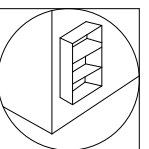
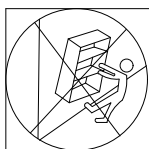
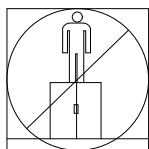
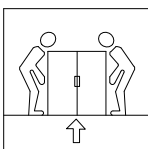
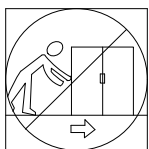
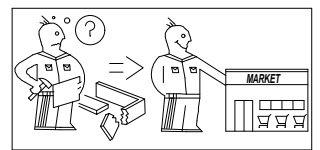
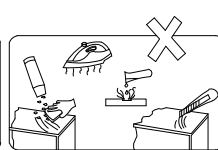
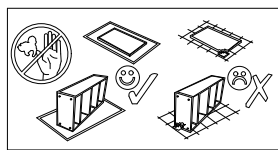
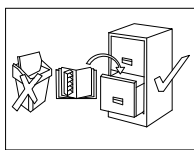
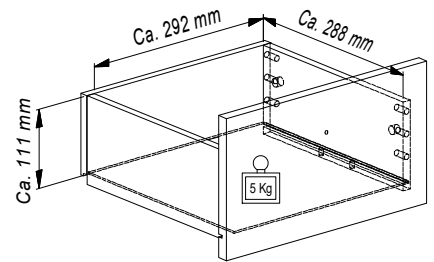
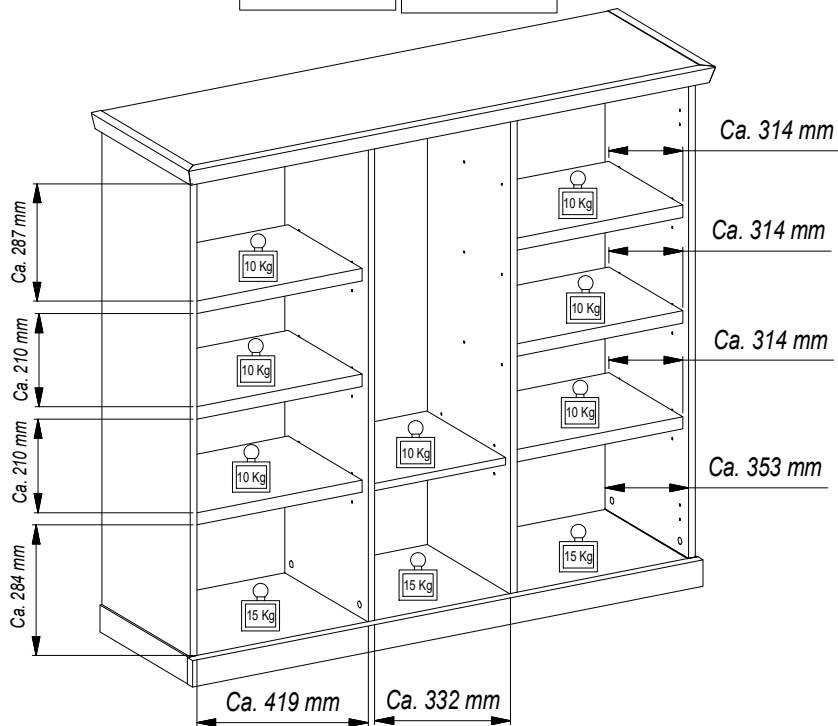
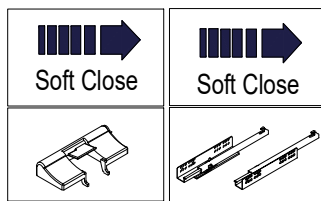
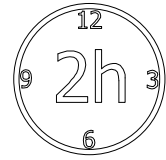
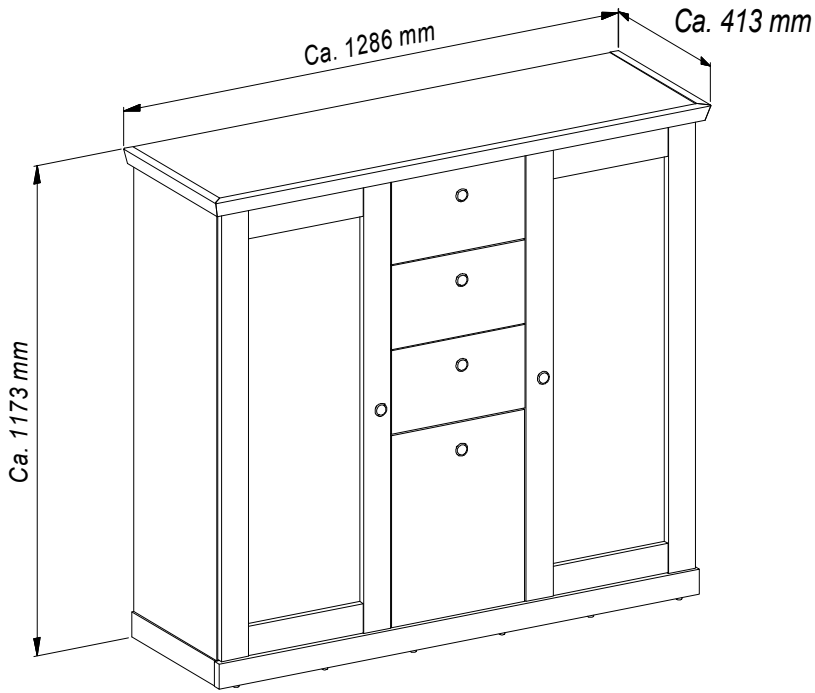

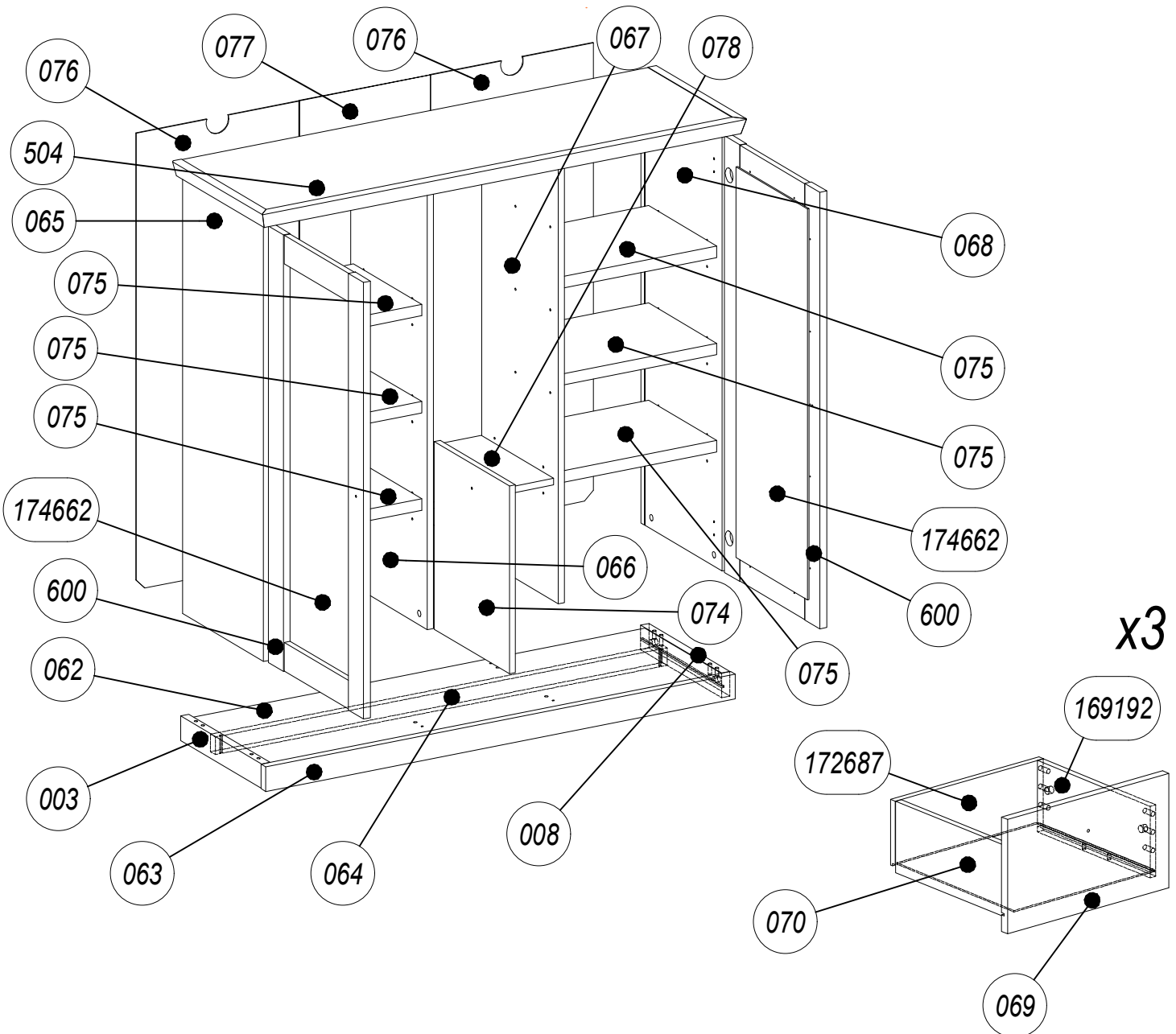







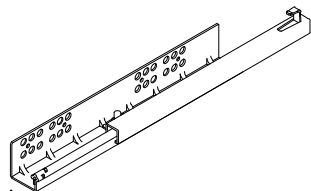
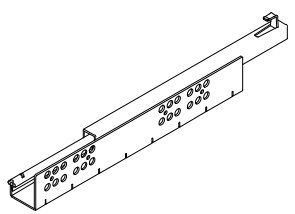
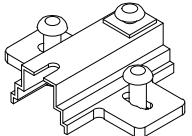
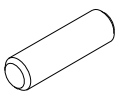
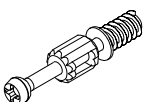

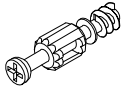
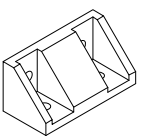
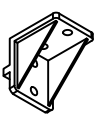

LINCOLN

5S MC LN 56

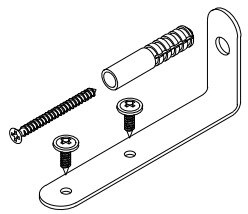
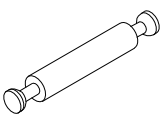
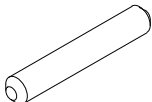

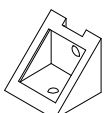
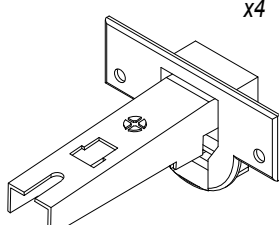
AI No.	QTY	H [MM]	W [MM]	D [MM]	PKG
003	1	373	60	22	1/2
008	1	373	60	22	1/2
062	1	1200	353	16	1/2
063	1	1247	60	22	1/2
064	1	1200	43	22	1/2
065	1	1096	373	16	1/2
066	1	1097	353	16	2/2
067	1	1097	353	16	2/2
068	1	1096	373	16	1/2
069	3	346	200	16	2/2
070	3	302	300	2,5	1/2
074	1	460	346	16	2/2
075	6	418	314	28	2/2
076	2	1118	432	2,5	1/2
077	1	1118	347	2,5	1/2
078	1	331	333	16	2/2
169192	6	288	125	12	1/2
172687	3	318	125	12	1/2

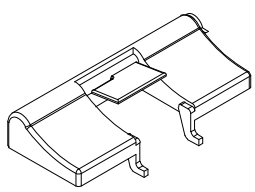
AI No.	QTY	H [MM]	W [MM]	D [MM]	PKG
174662	2	957	329	4	2/2
504	1	1286	413	38	1/2
600	2	439	1069	18	1/2

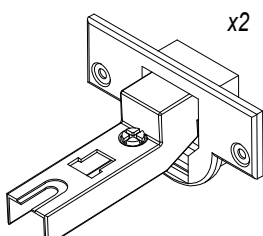
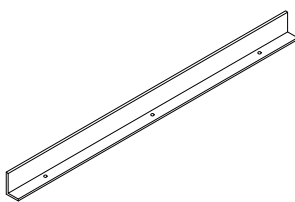
 EURO S Ø6x9,5 x12 1007	 US Ø3,5x13 x104 1011	 L-300 x3 148354	 L-300 x3 148355
 H-4 x6 23515	 Ø8x28 x36 1018		
 L-38 mm x12 11809	 Ø15x12,5 mm x20 123894	 Ø12x10 mm x12 76082	 L-31 mm x12 10835
 127314 x2	 127317 x12	 1289 x28	 1305 x16
 1302 x31	 UP Ø3x20 x28 1056	 23x10x2 x16 1415	 1267 x2
 L-48 mm x4 18264	 Ø8x50 x4 1272	 Ø20 x16 9129	
 174693 x6	 Ø35 KR 0 x4 21887	 Ø13 x28 1356	 US Ø3x16 x28 1073
 SOFT CLOSE x3 116795		 174666 x6	 WPM Ø4x22 mm x6 2549
	 Ø35 KR 8 mm x2 22311	 L-418 mm x2 175394	

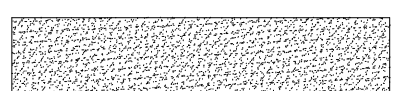
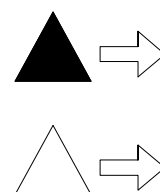
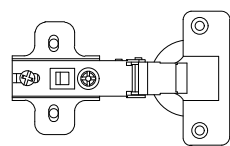
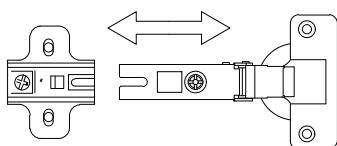

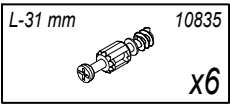

1

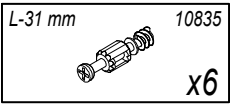
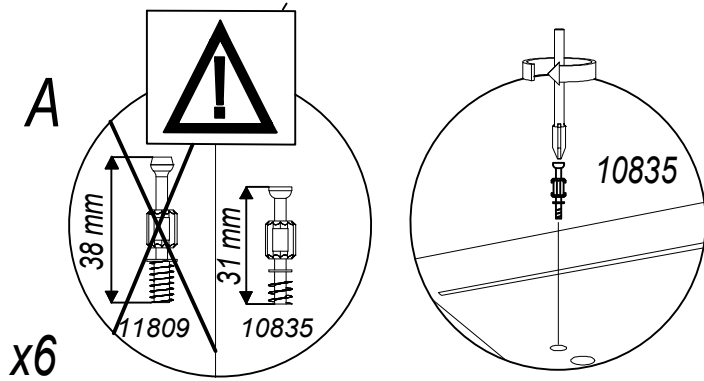
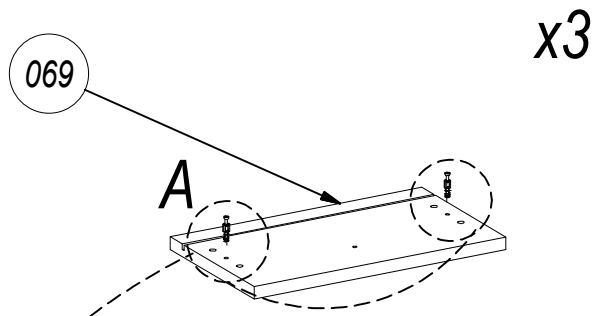

2

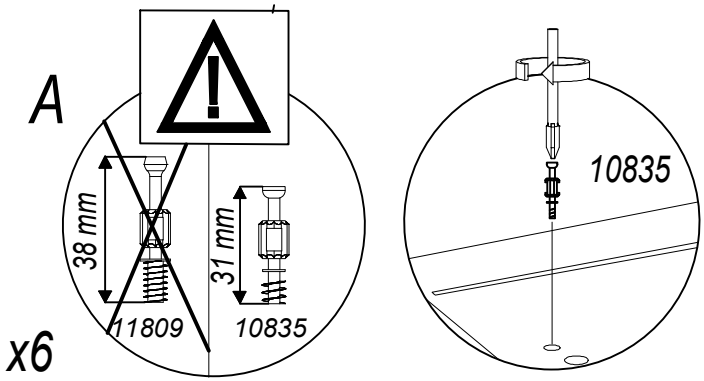
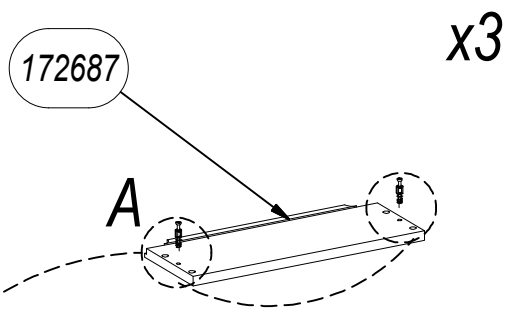

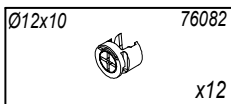
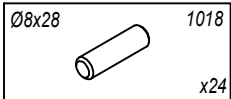

169192 x6

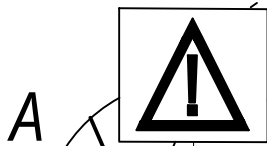
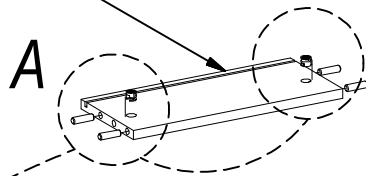

A

x12

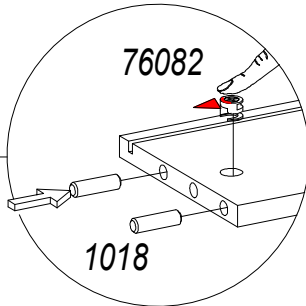
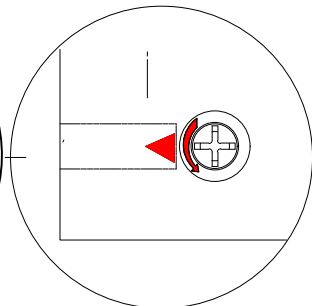
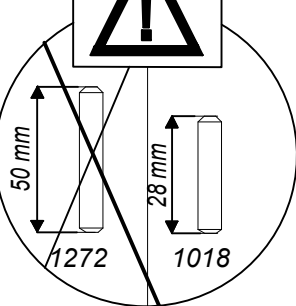

169192 x3

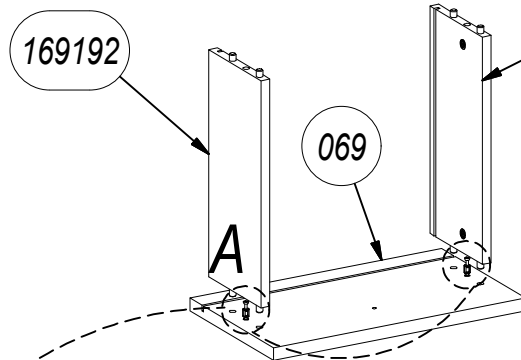

A

x6

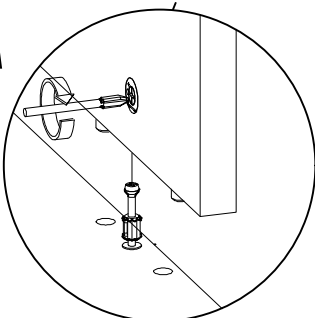

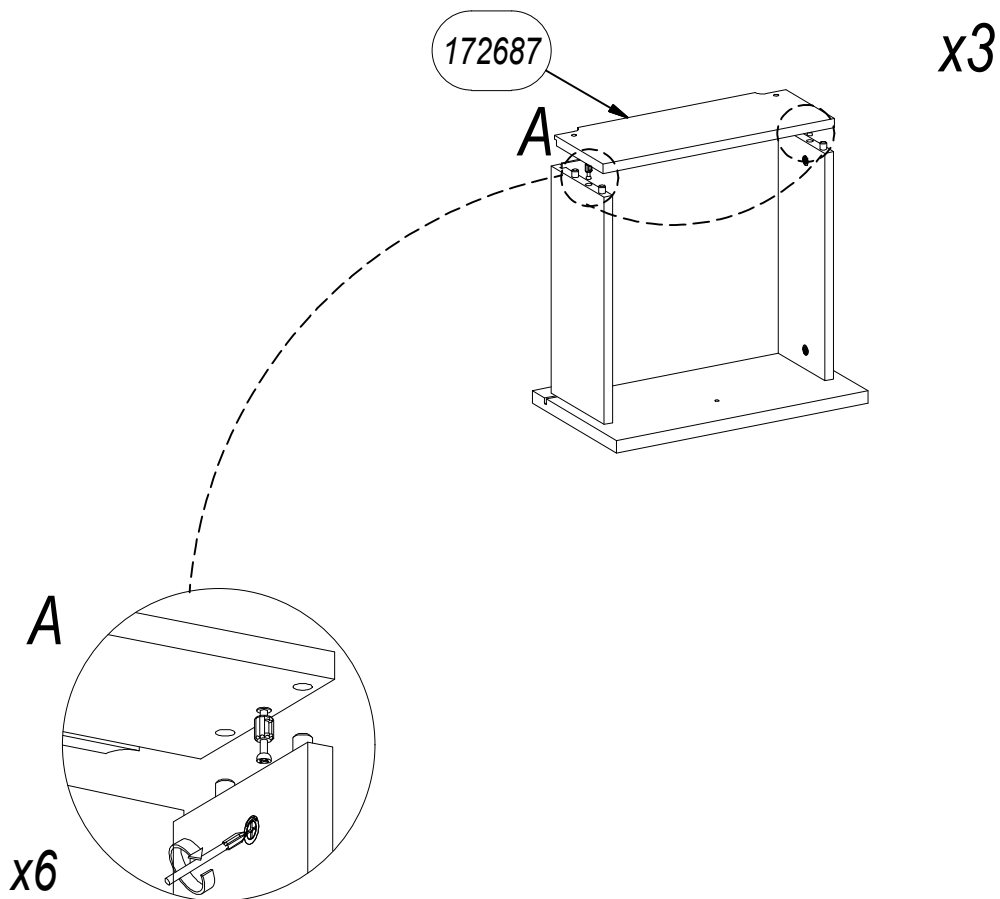
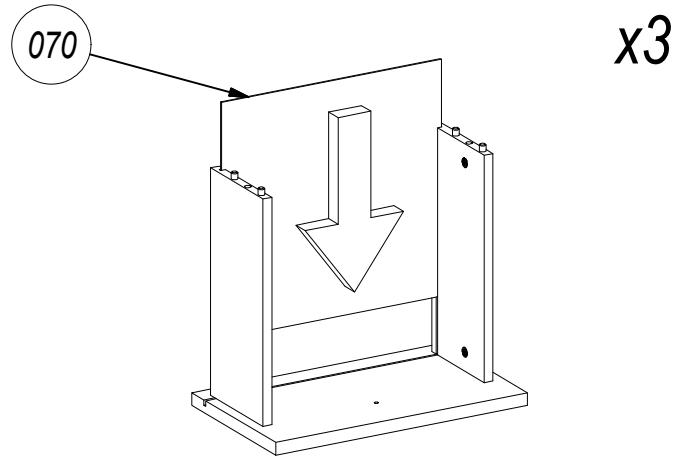

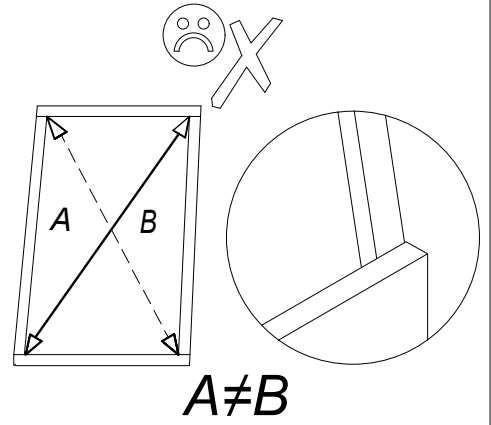
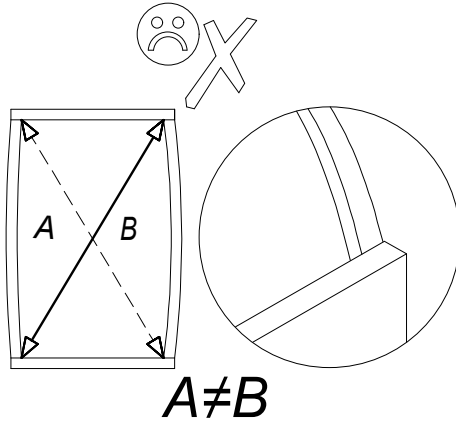
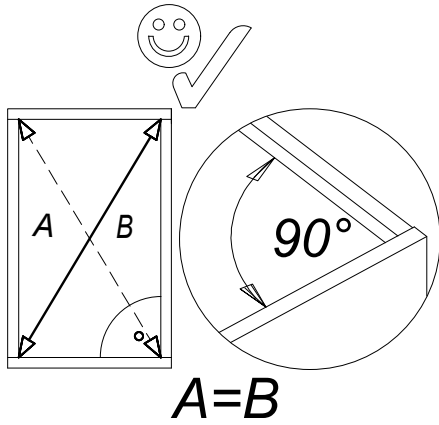
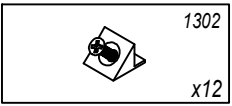

x3

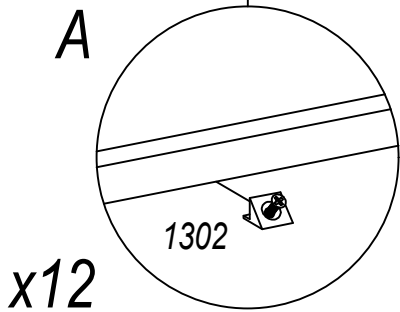
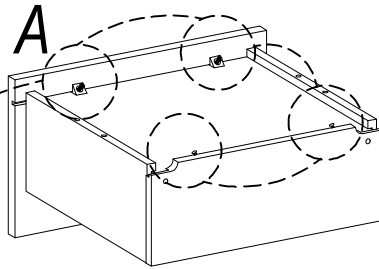



174693
x6

US Ø3,5x13



1011
x6

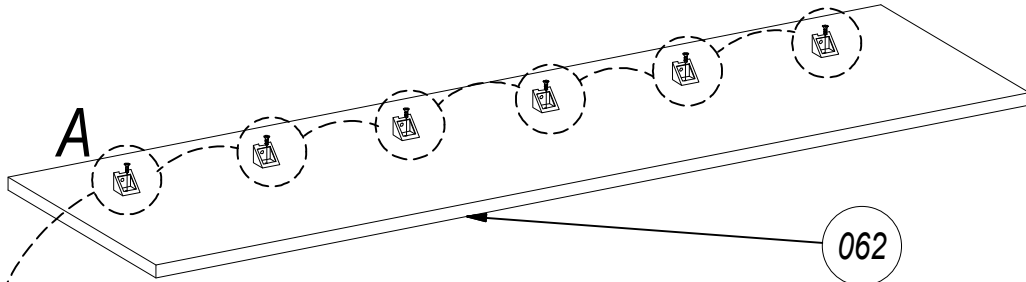

062

A

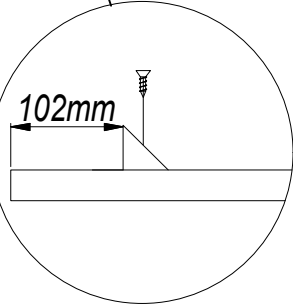

102mm

1011

174693

x6



30x30x3



127317
x2

US Ø3,5x13



1011
x4

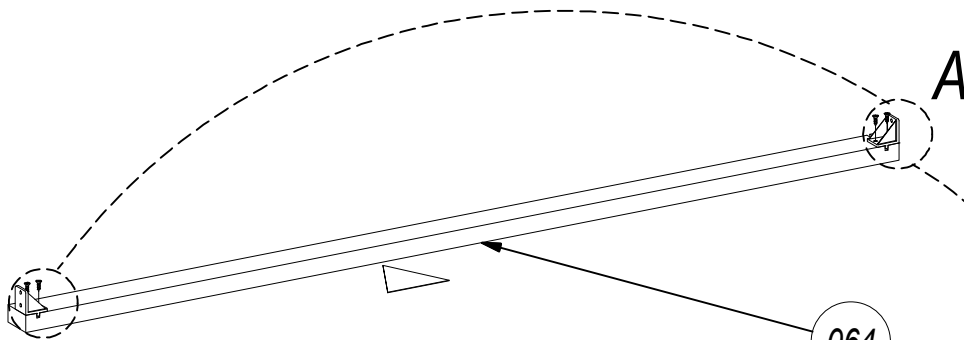

064

A

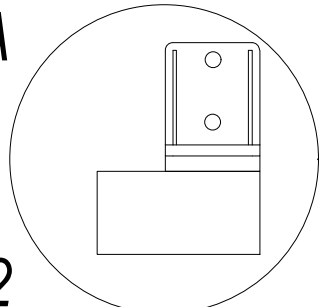

x2

1011

127317



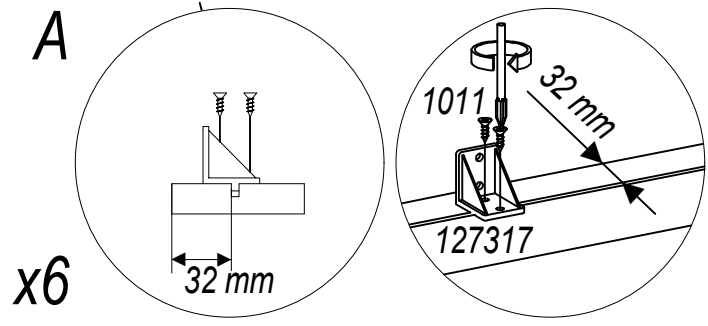
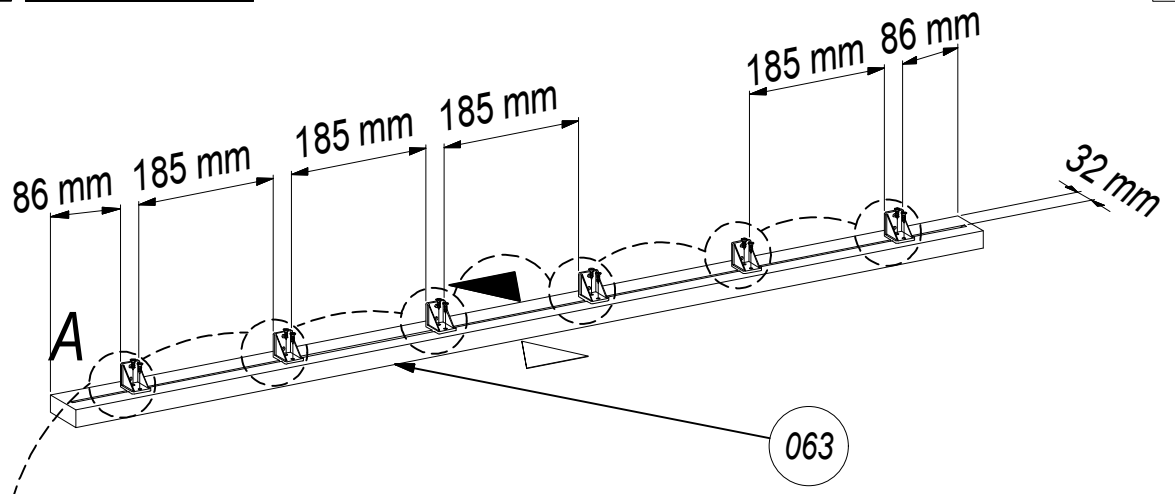
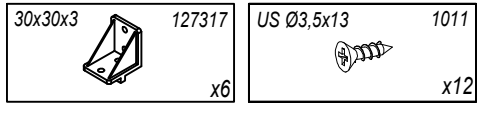
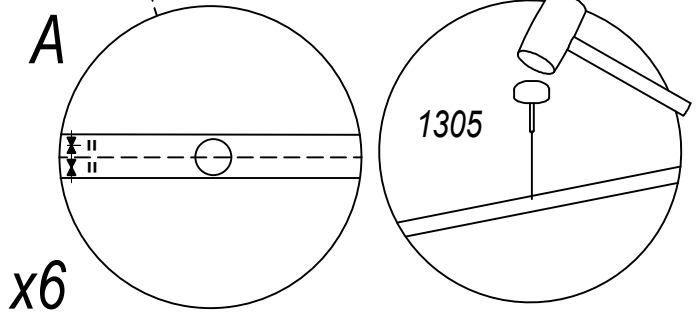
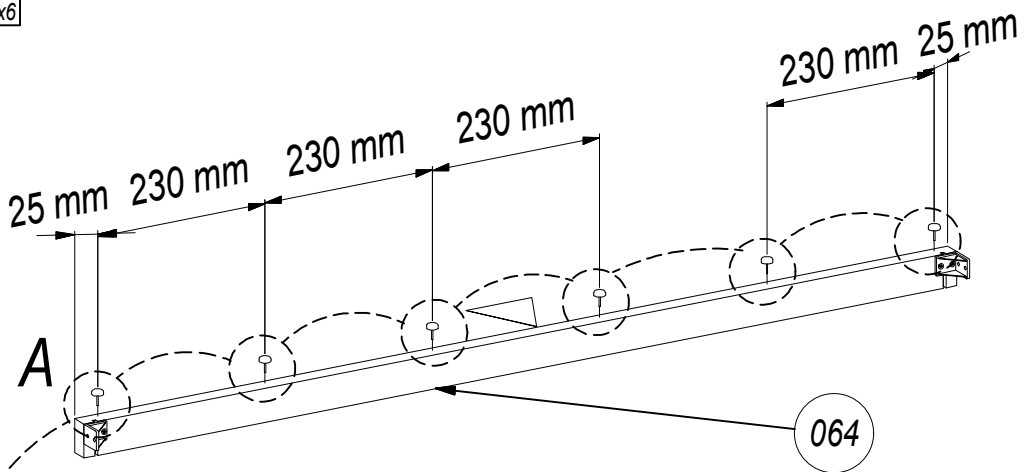
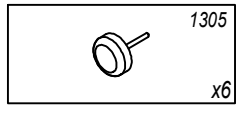

30x30x3
127317
x2

US Ø3,5x13
1011
x4

12

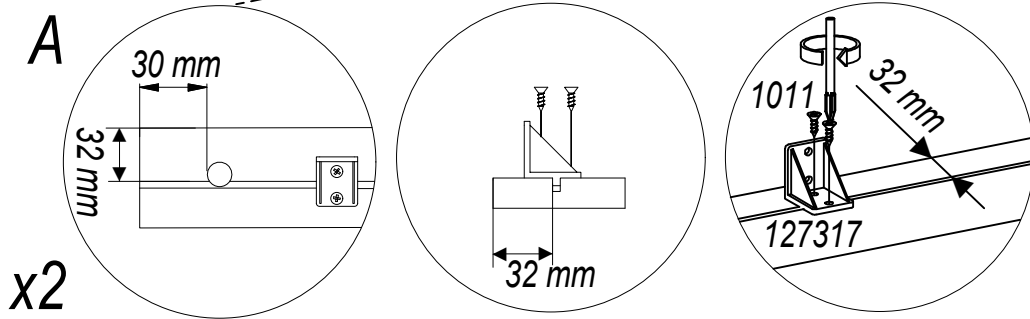
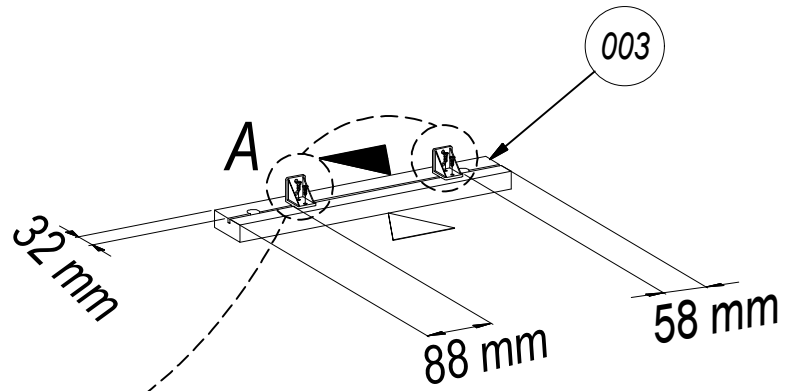



127314
x1

US Ø3,5x13
1011
x2

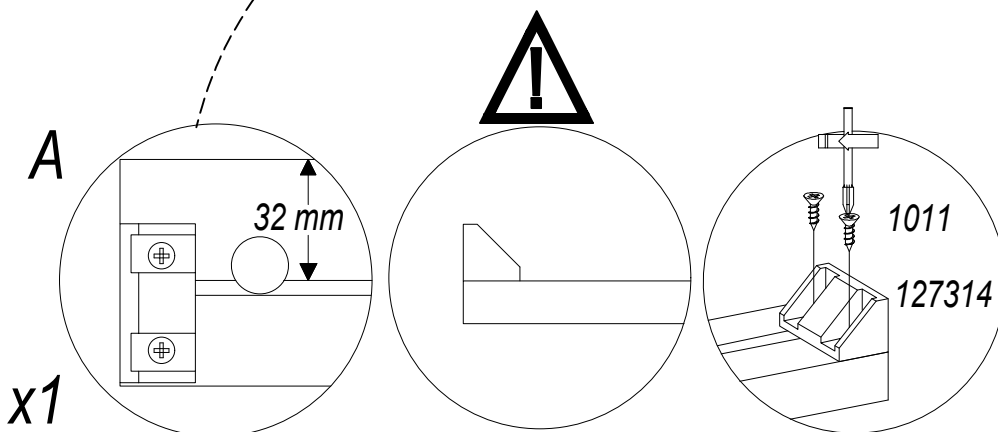
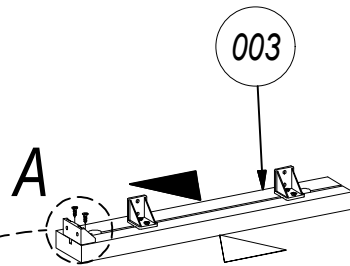

13

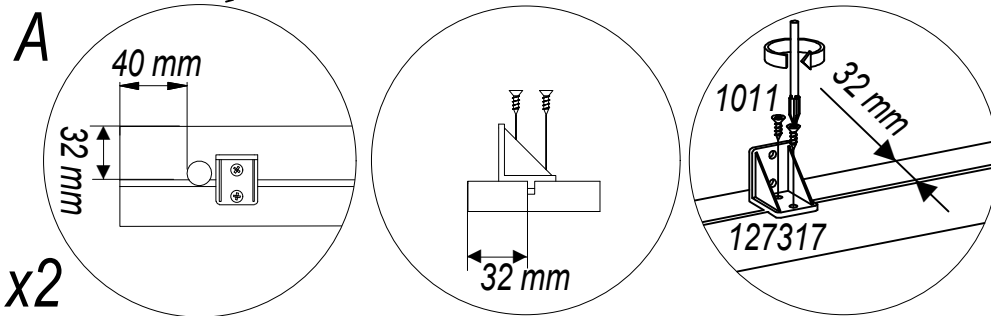
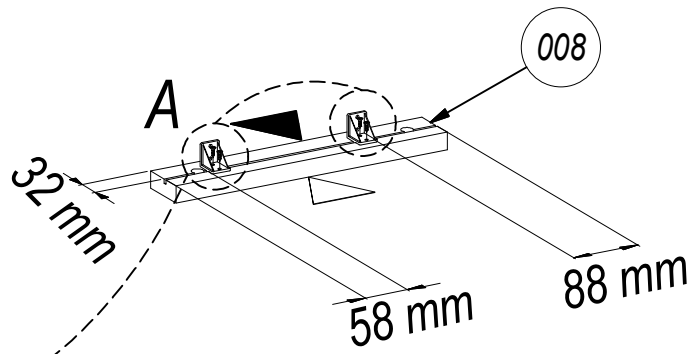

30x30x3	127317	US Ø3,5x13	1011
	x2		x4

14



127314	US Ø3,5x13	1011	
	x1		x2

15

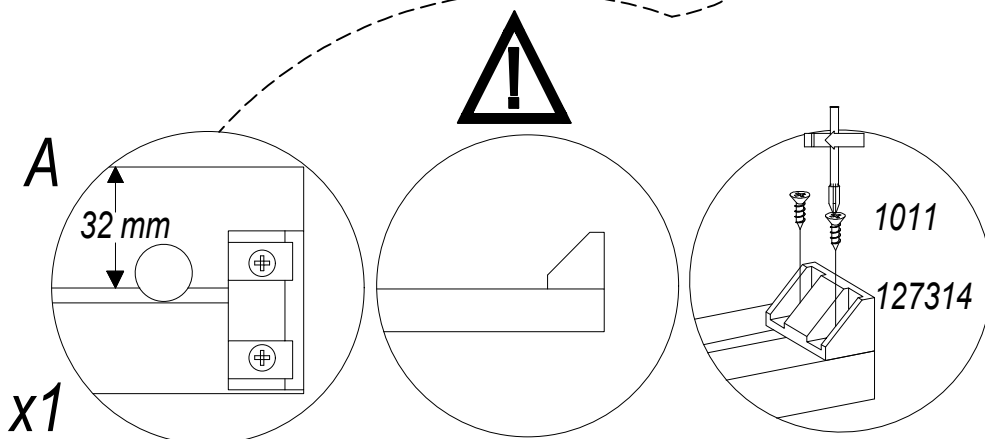
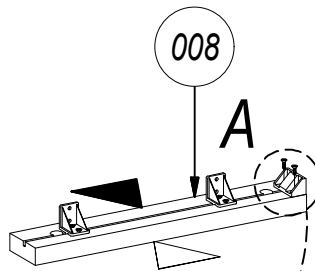

US Ø3,5x13 1011
x8

16

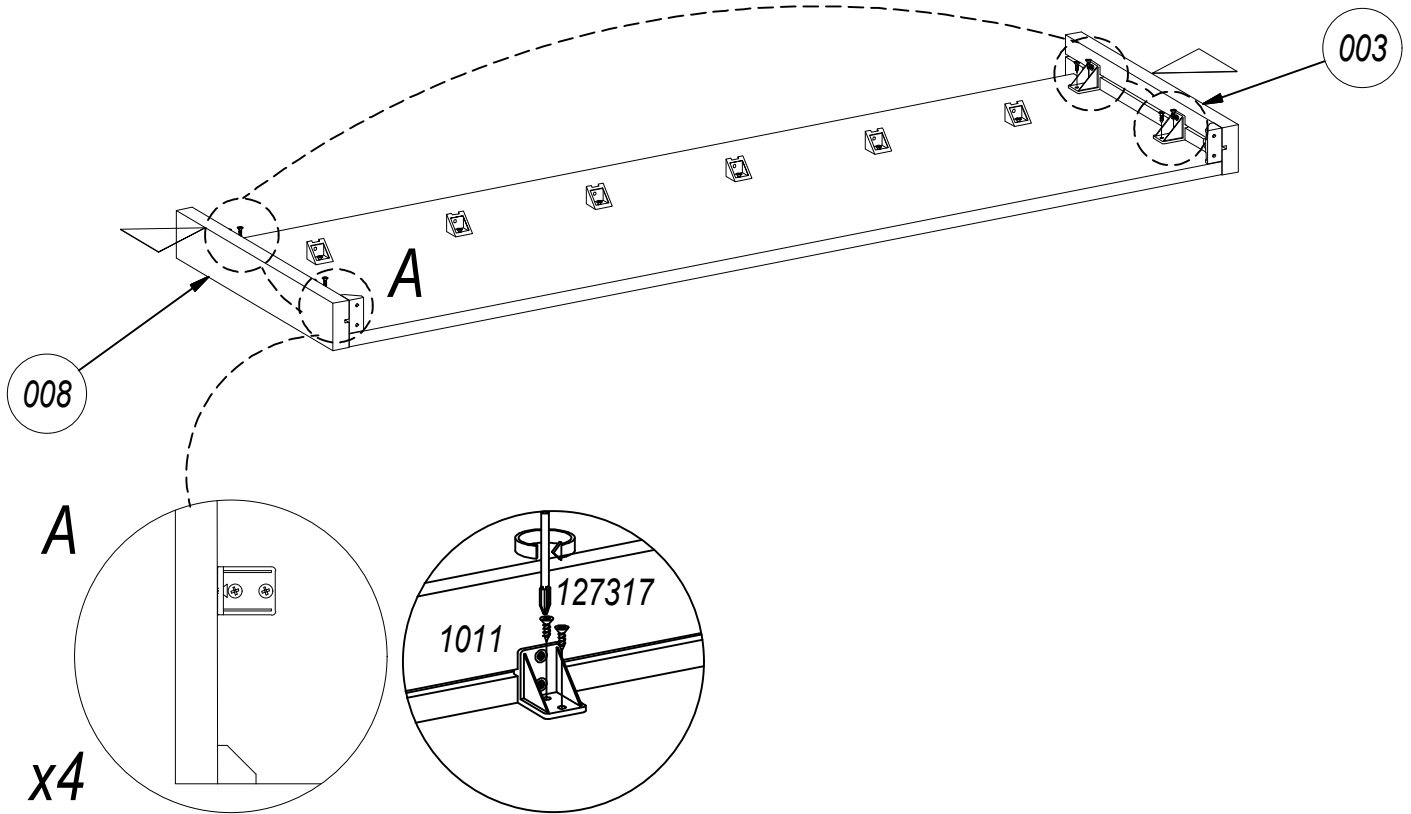

US Ø3,5x13 1011
x10

17

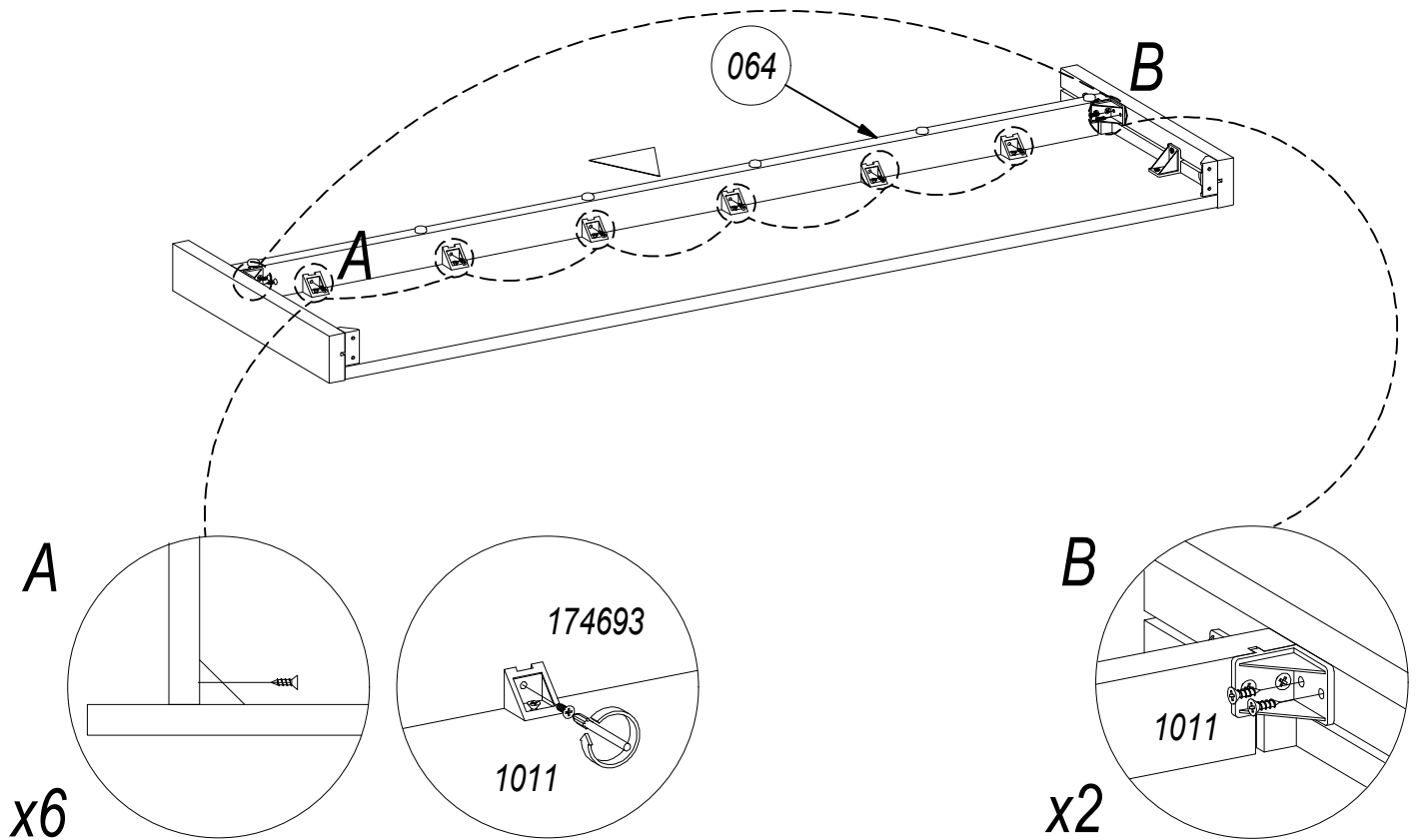

US Ø3,5x13 1011

 x16

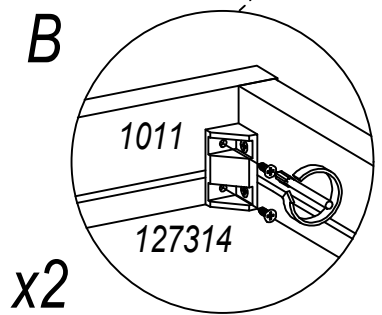
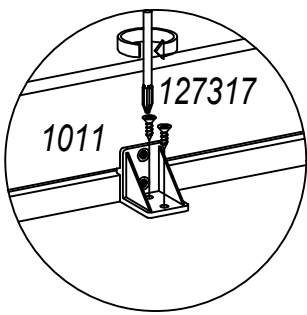
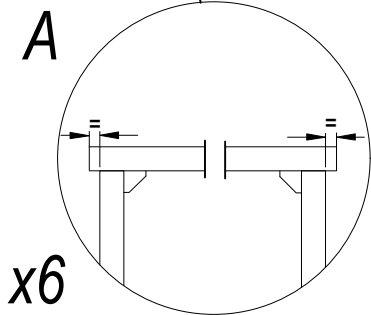
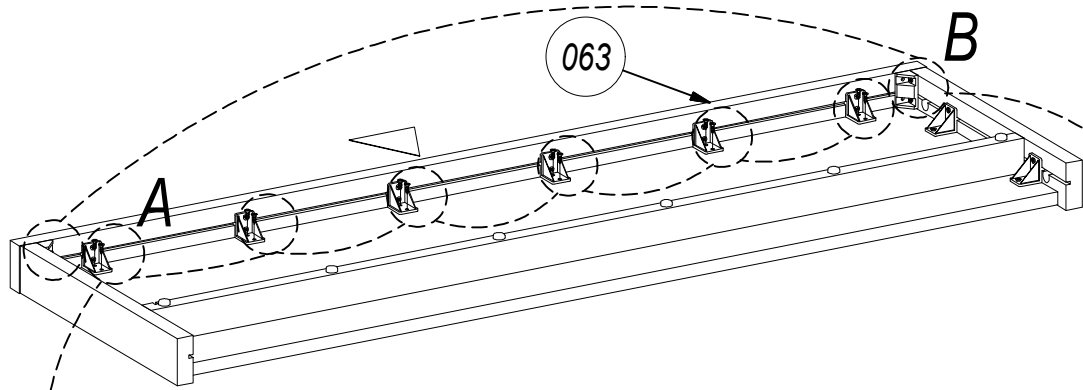
18



1305

 x10

19

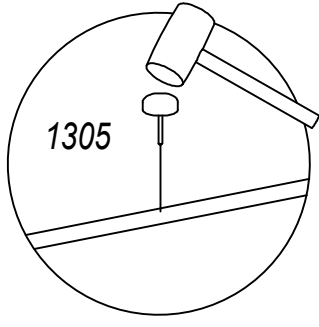
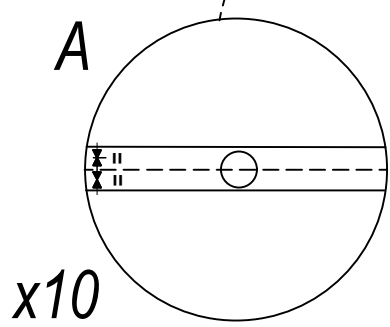
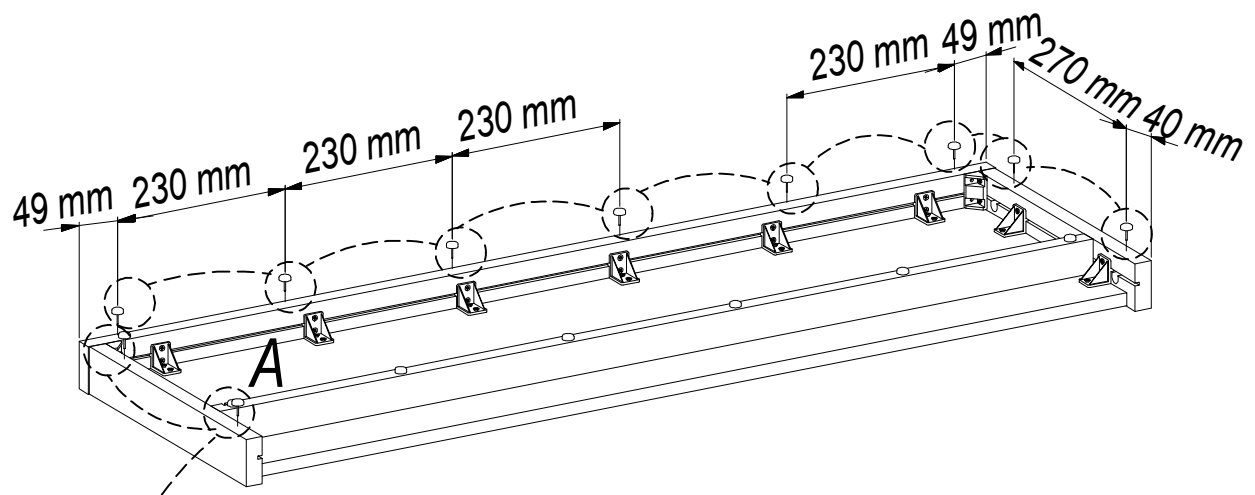

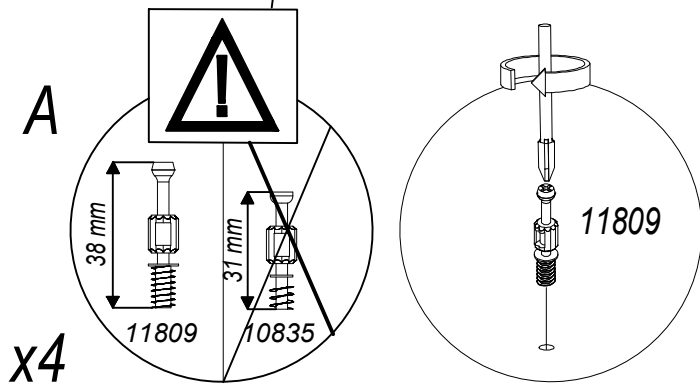
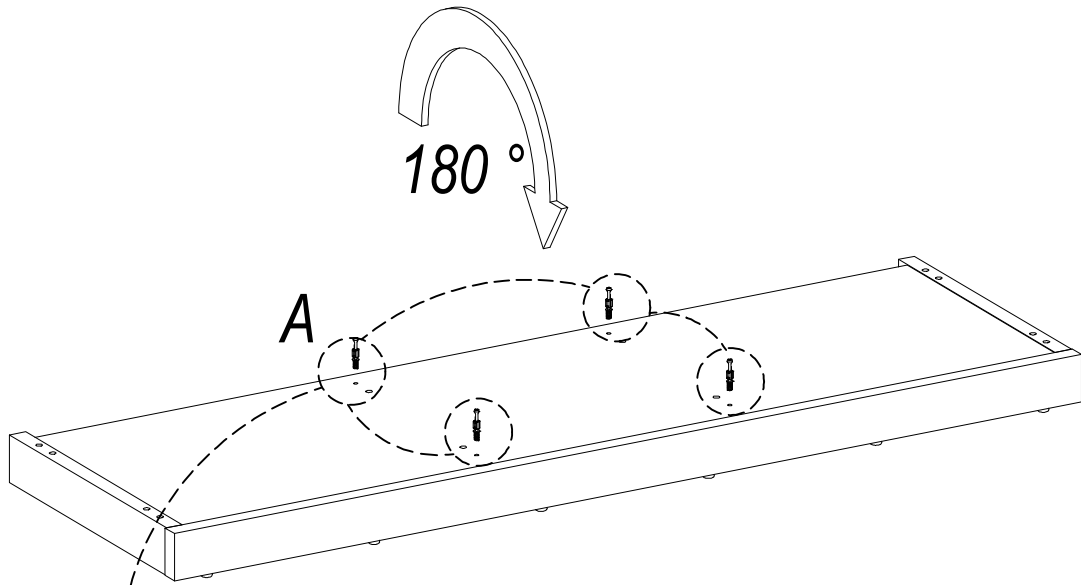
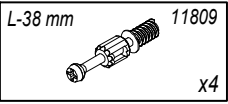

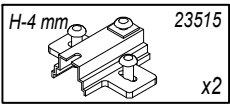

21

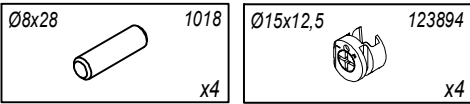
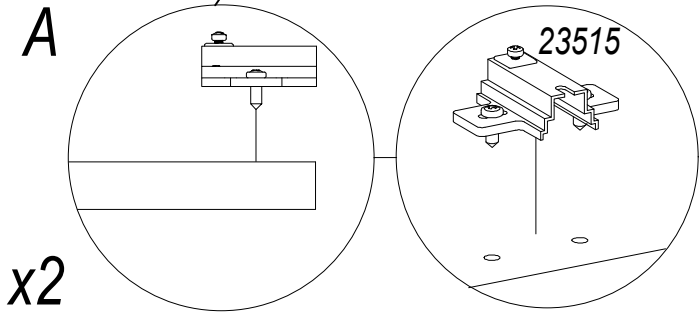
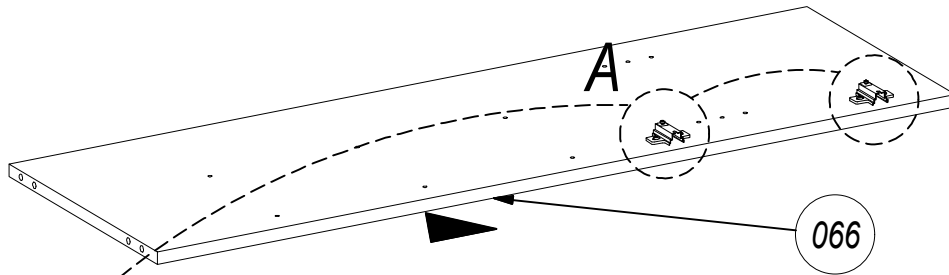

22

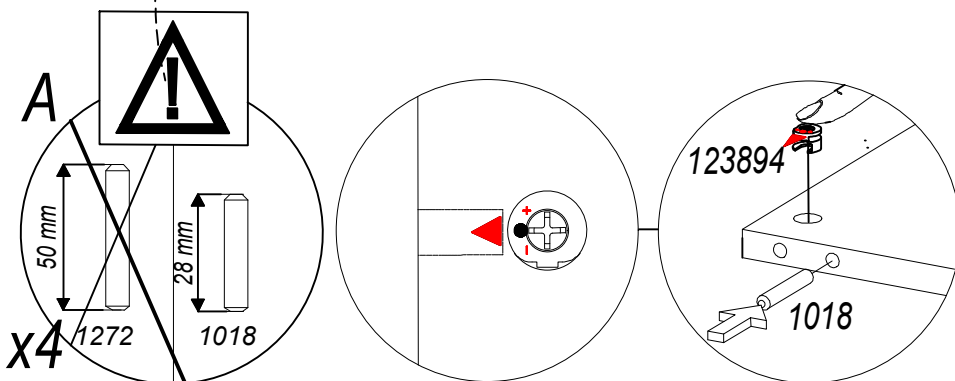
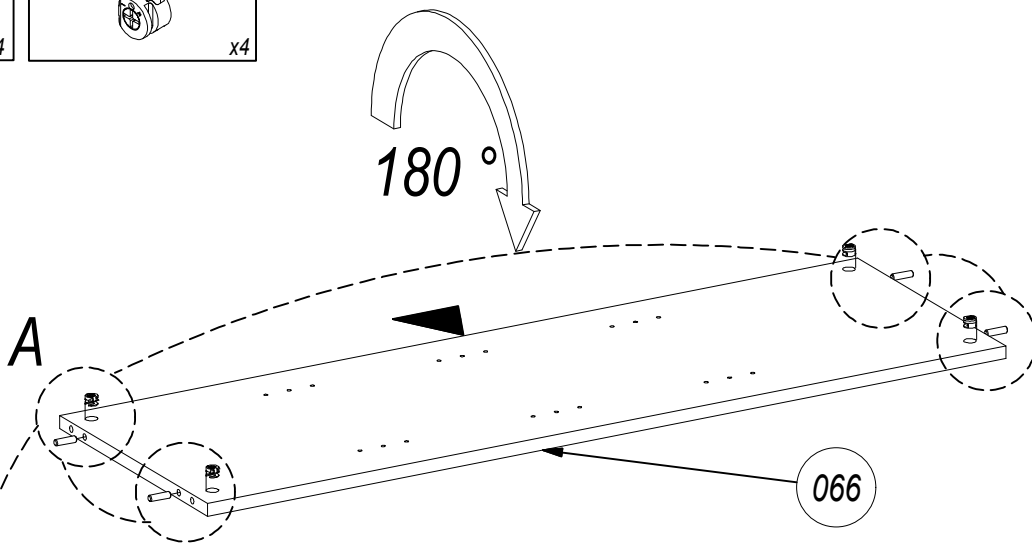

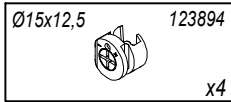
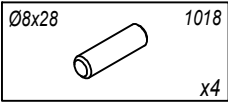

23

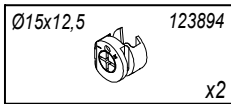
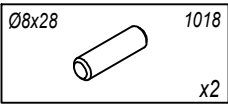
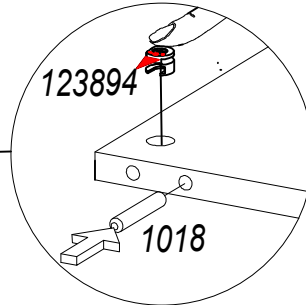
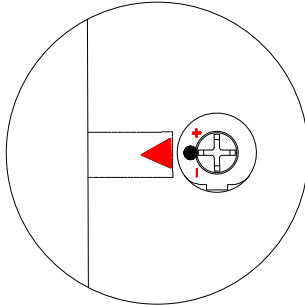
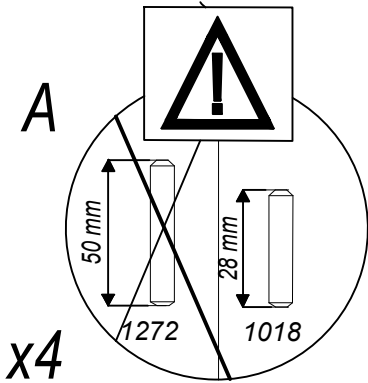
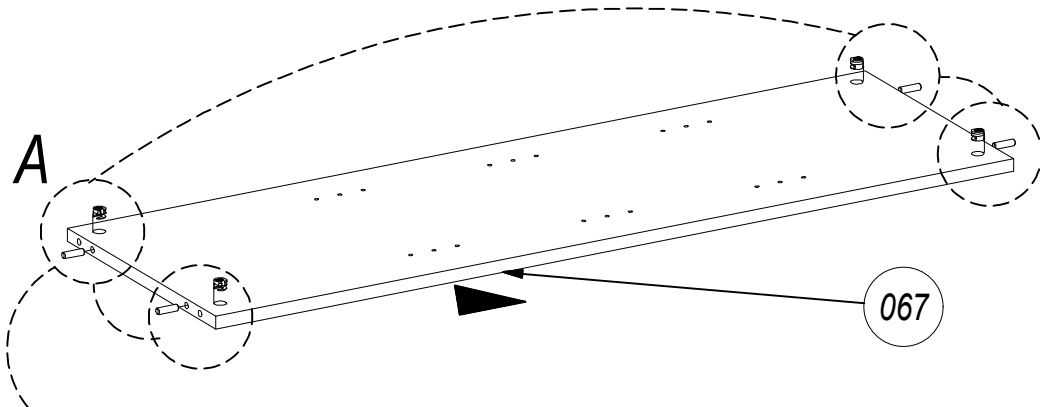

24

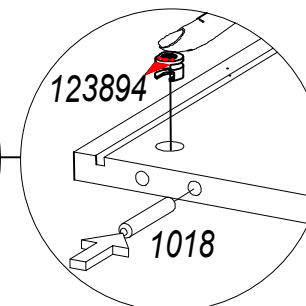
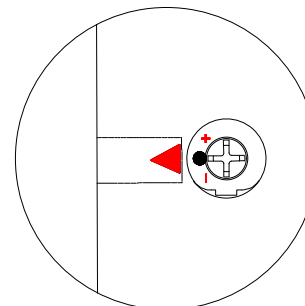
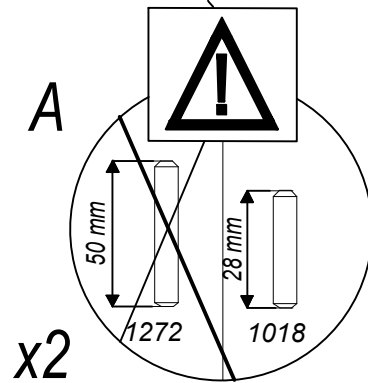
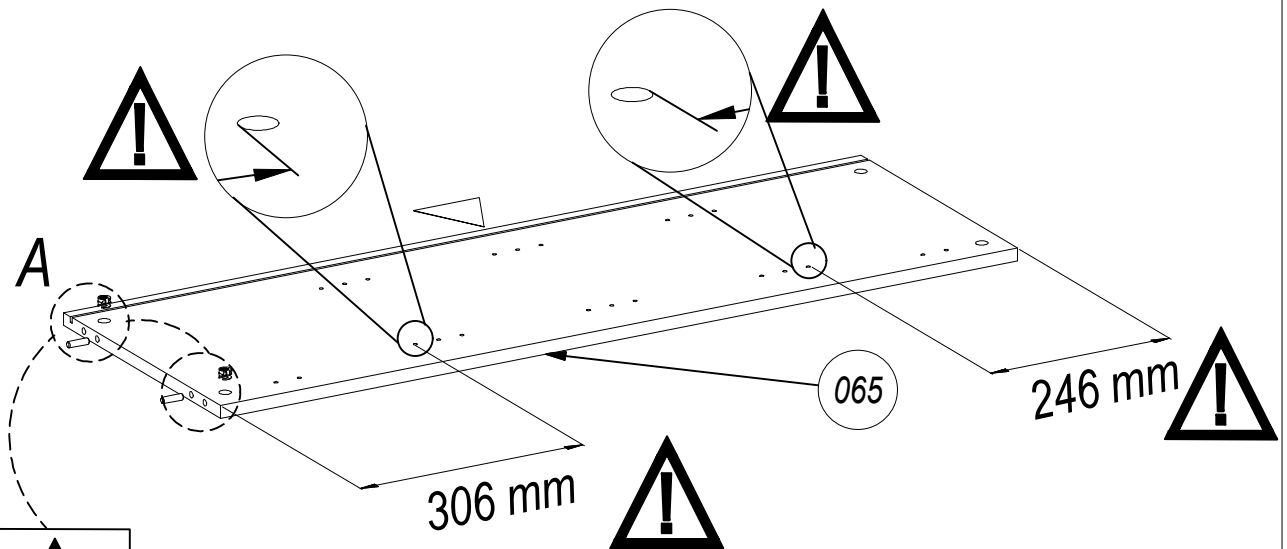

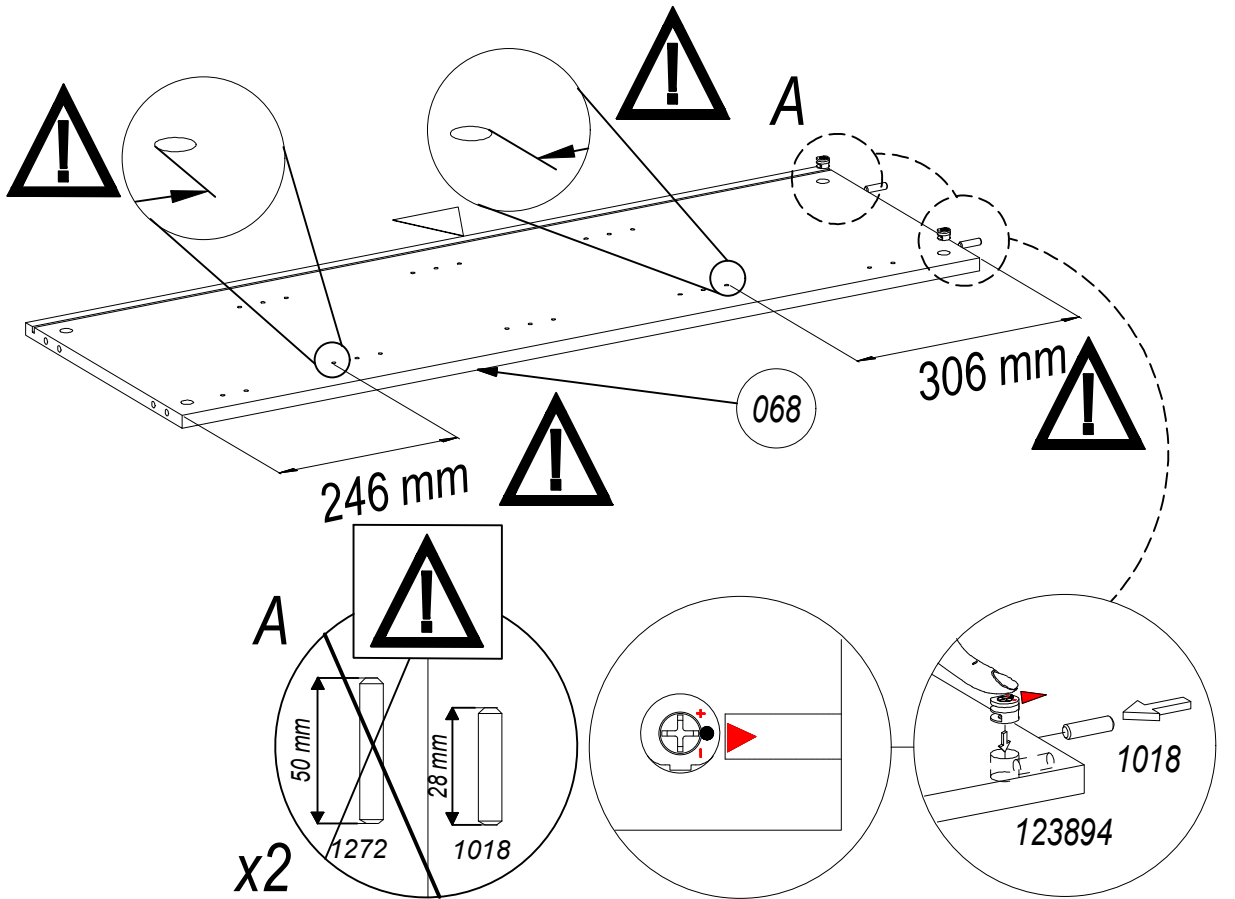
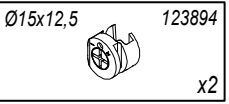
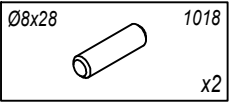
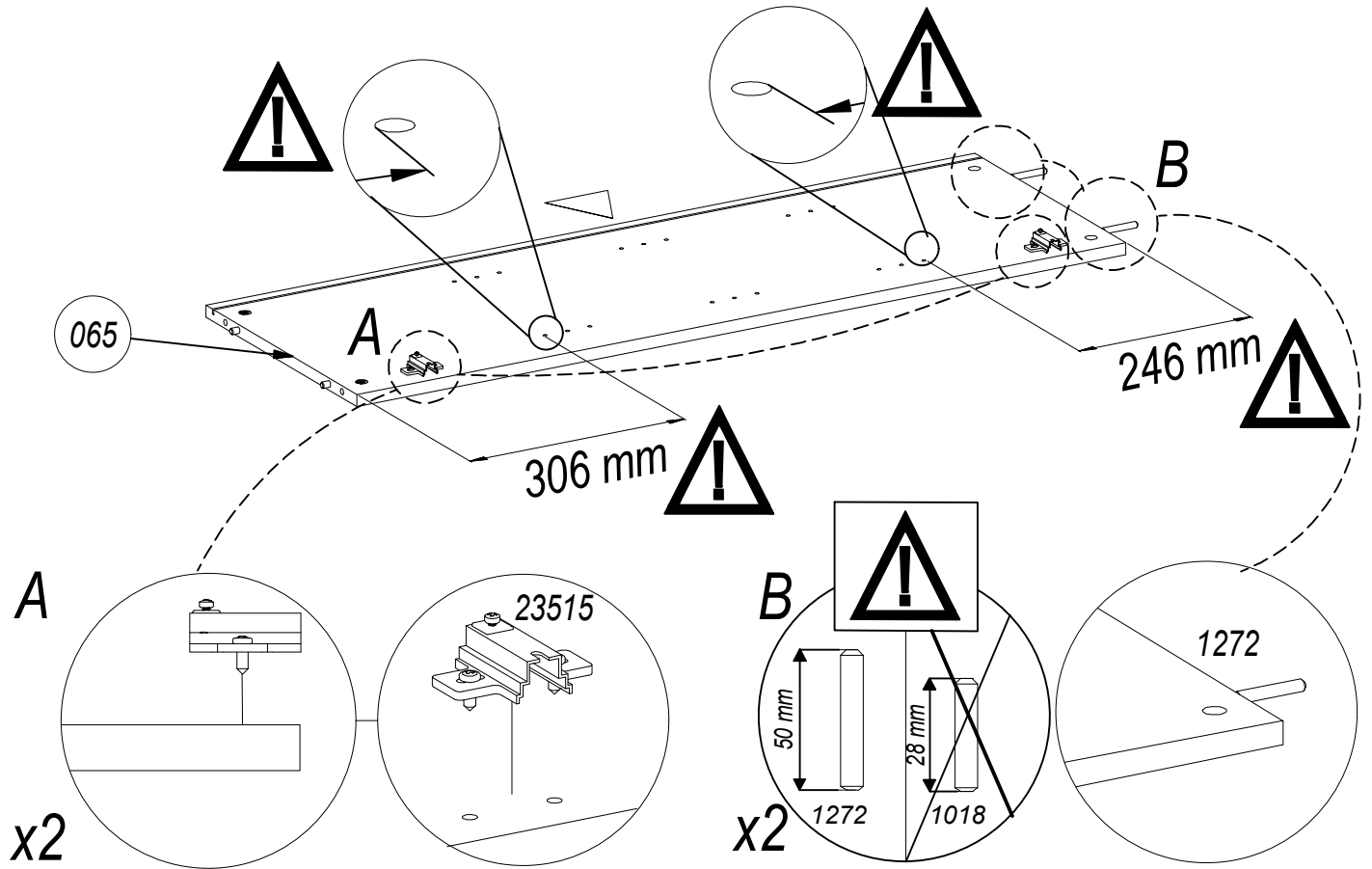
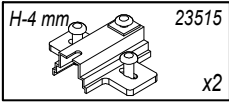
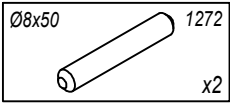

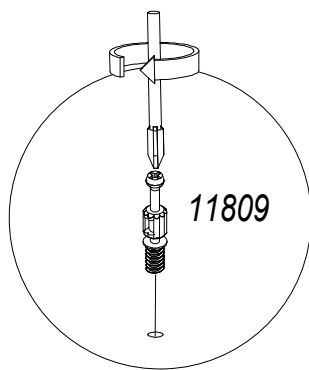
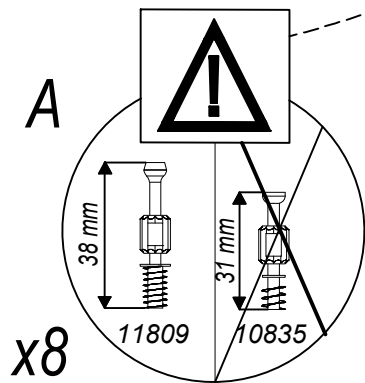
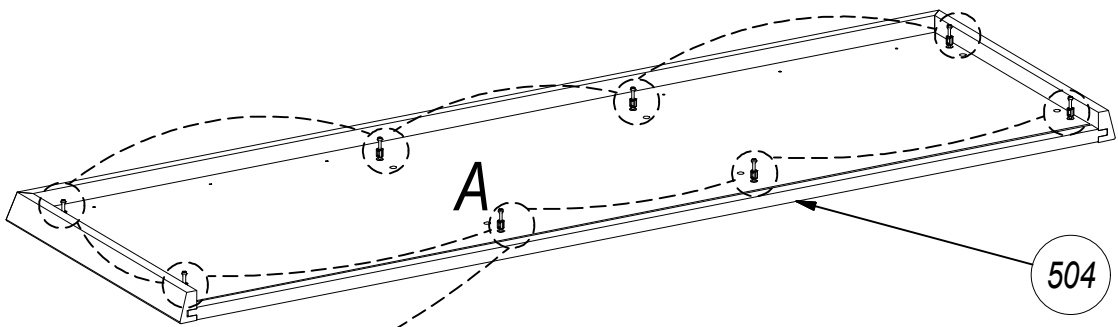
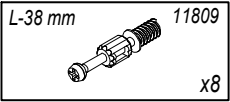
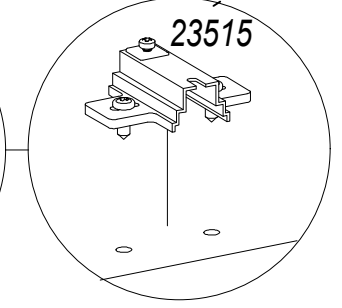
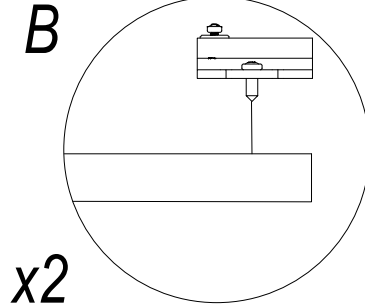
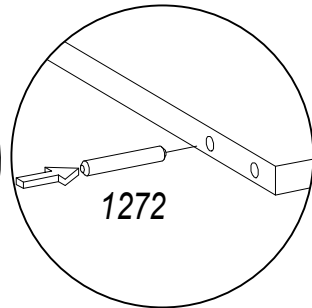
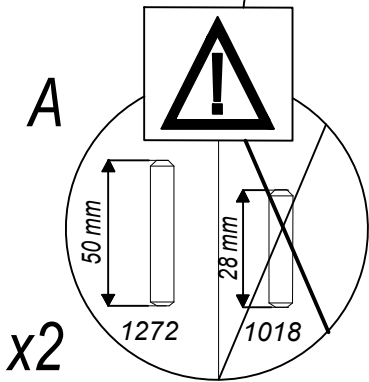
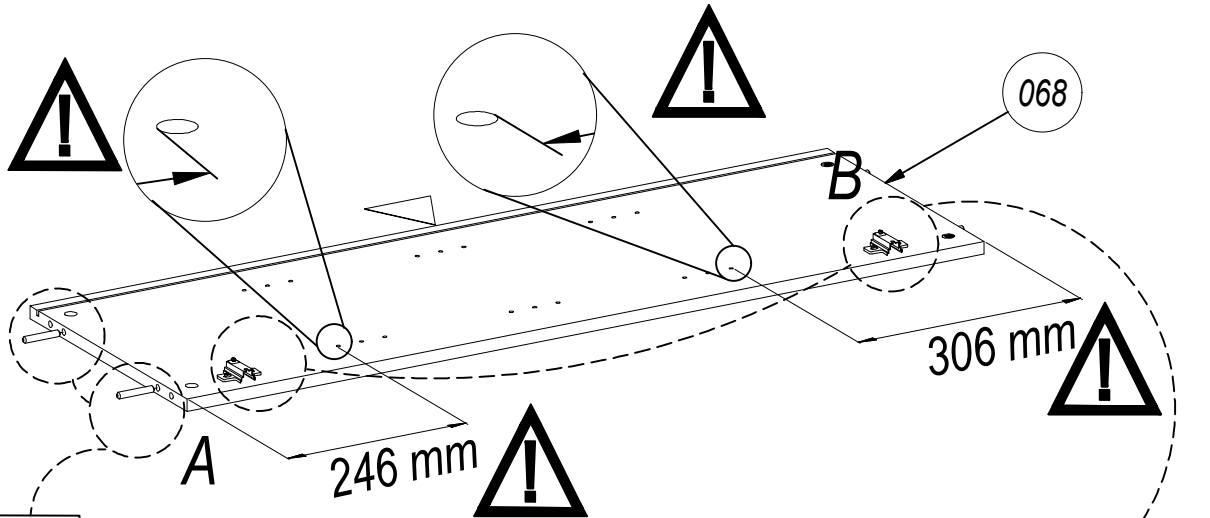
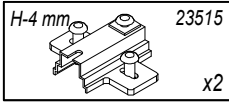
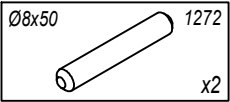

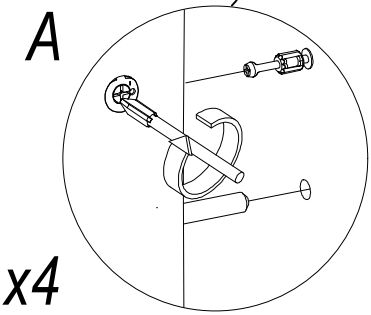
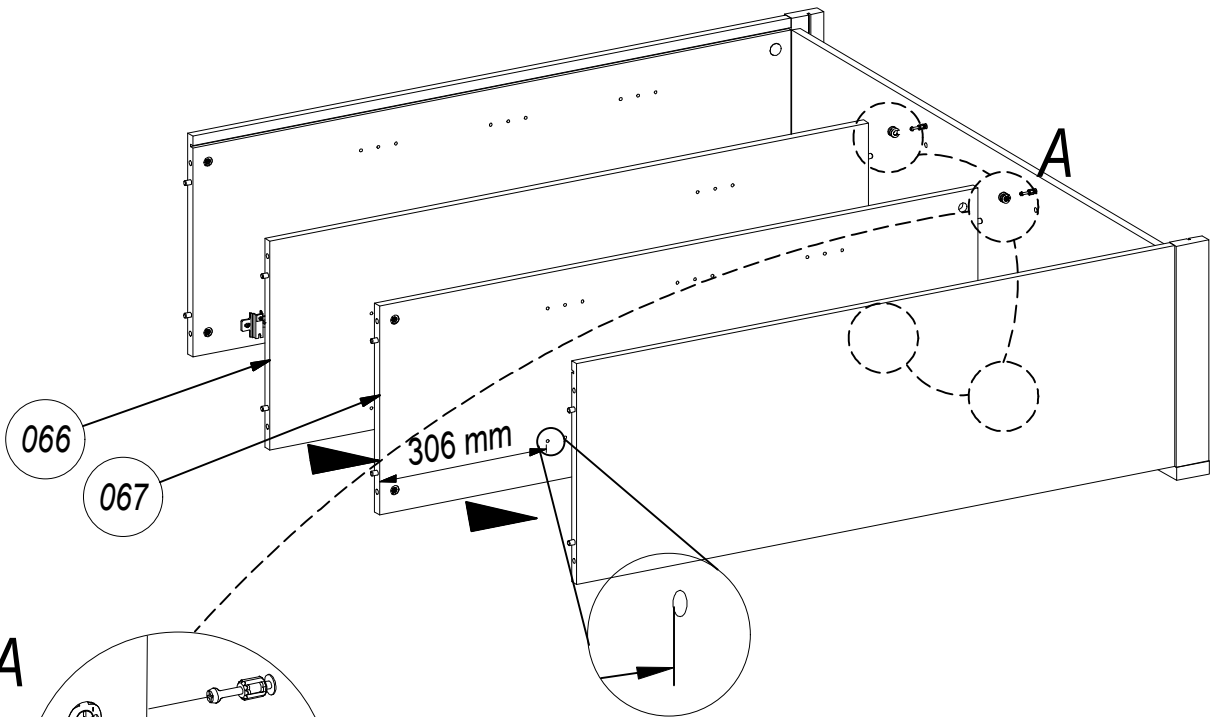
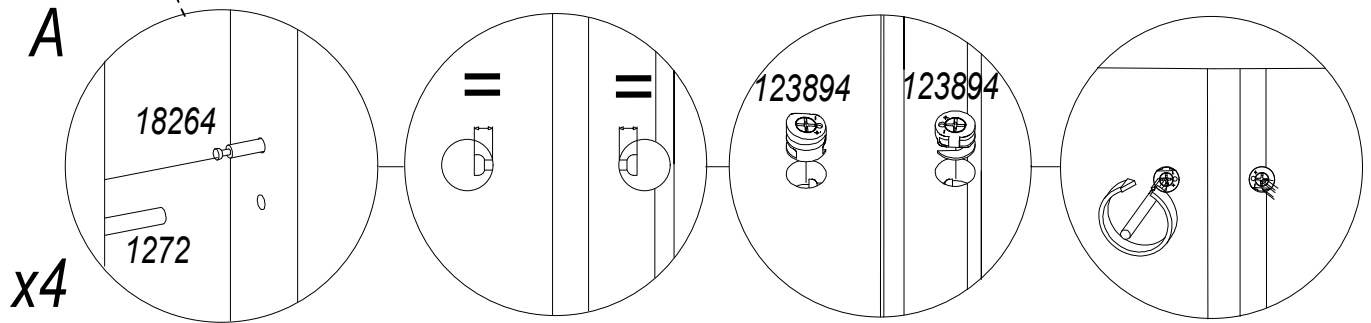
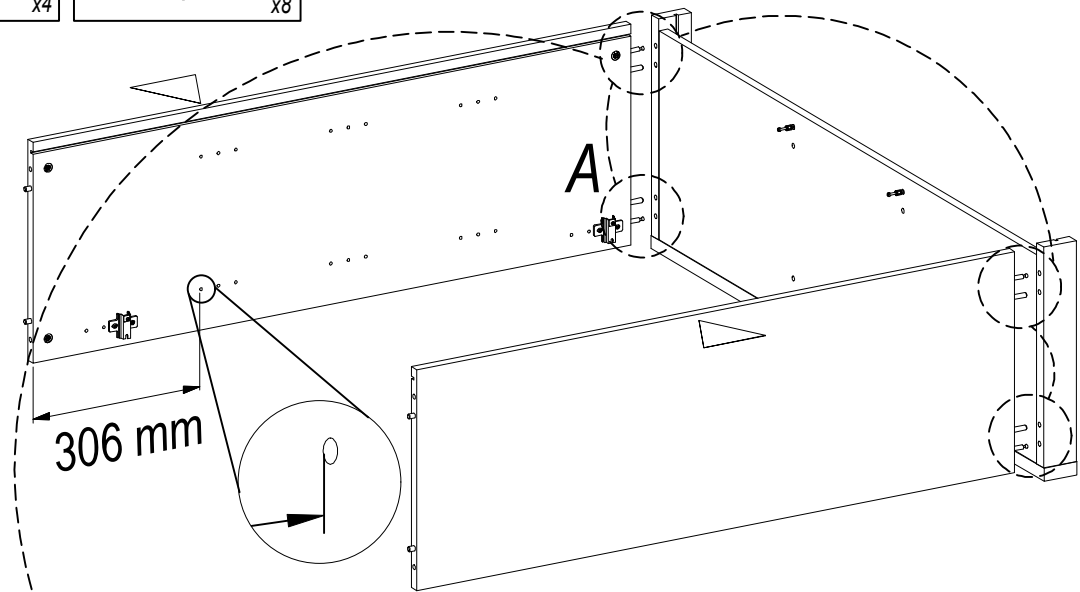
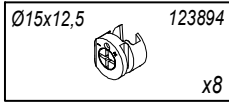
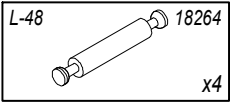

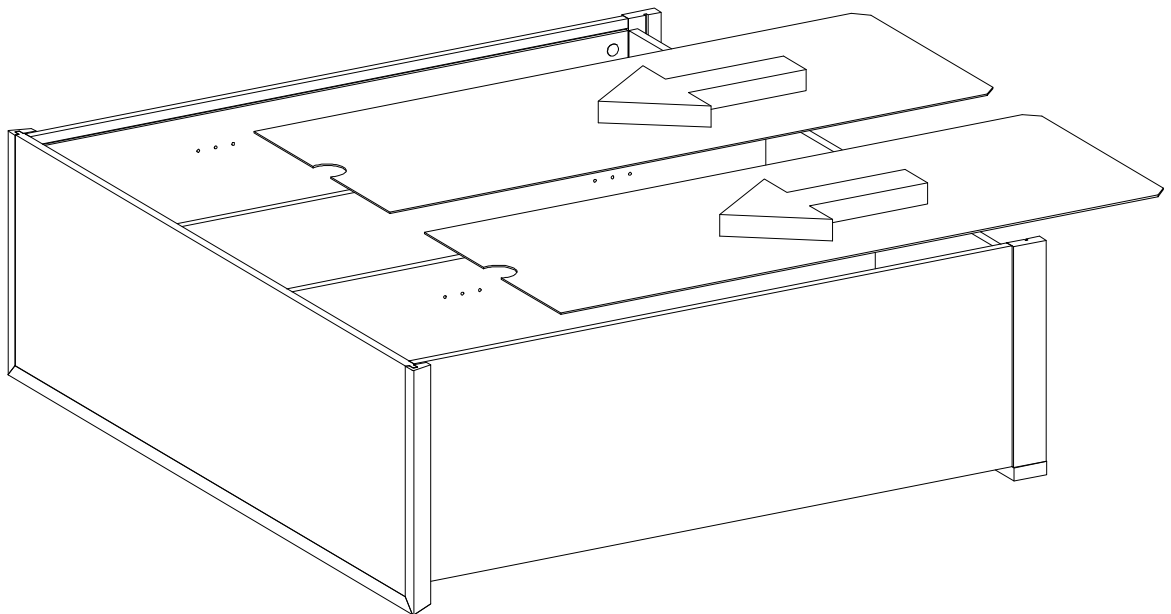
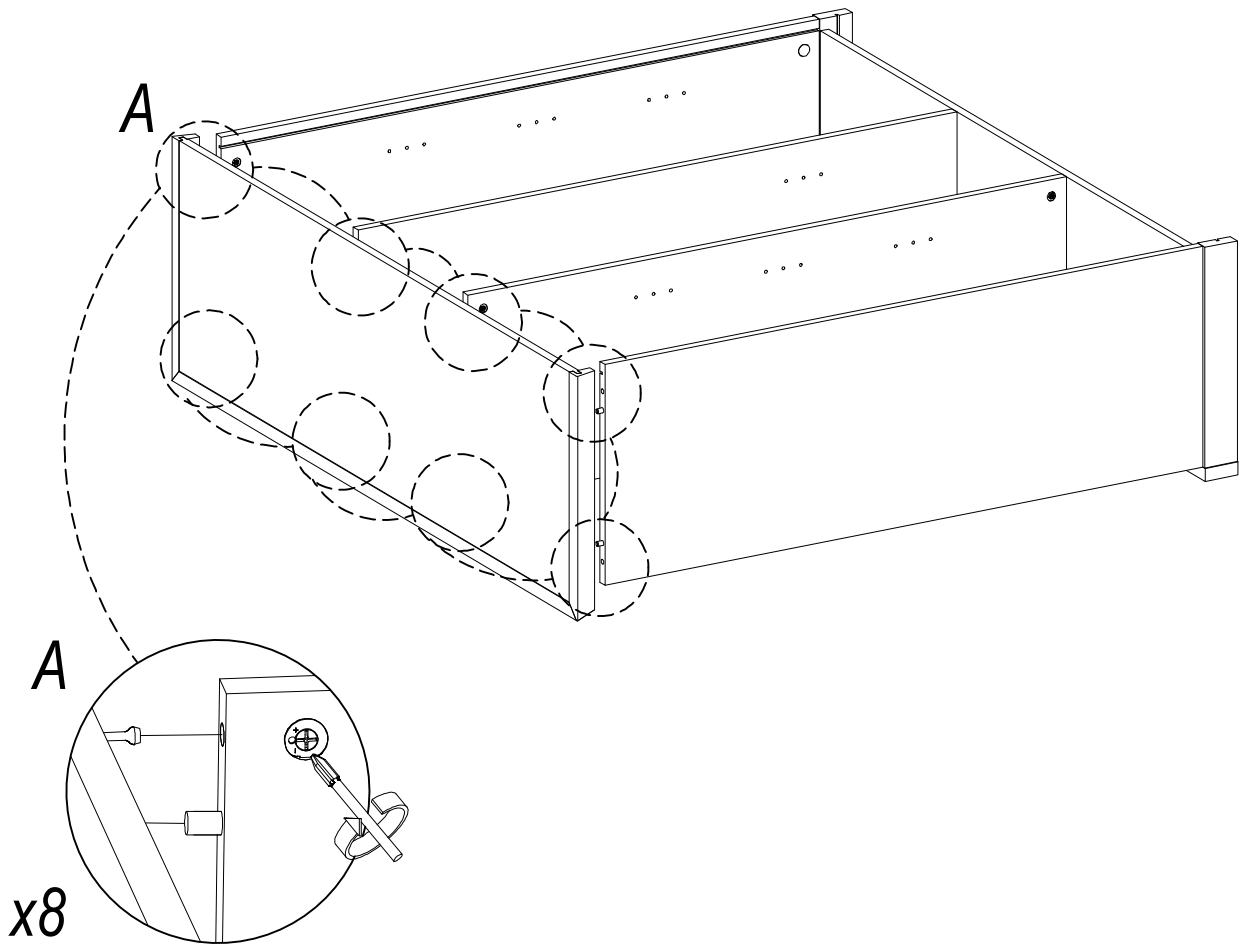

33

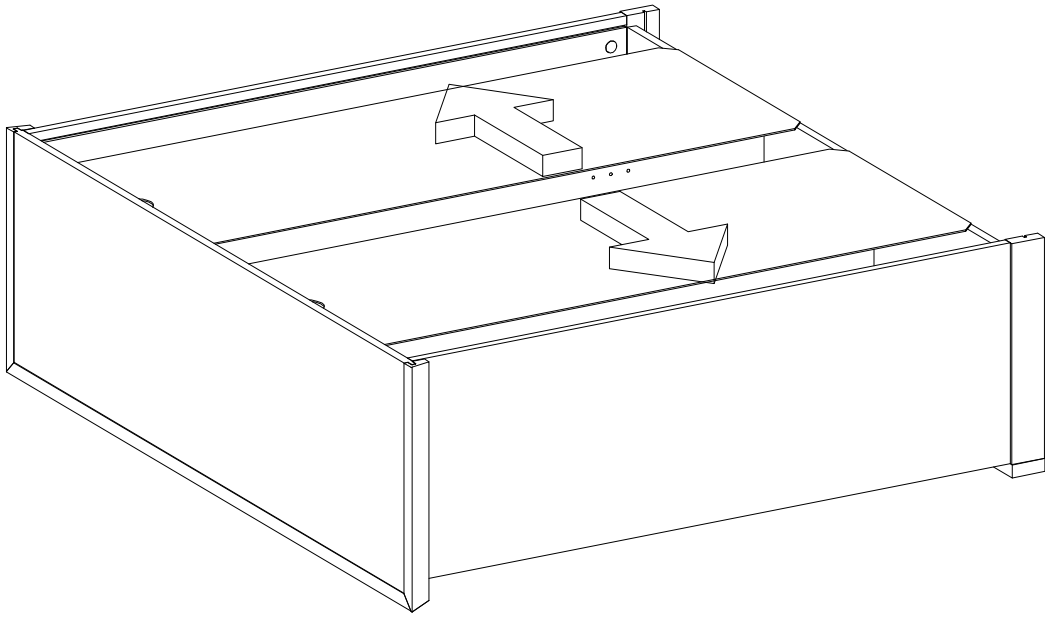

34

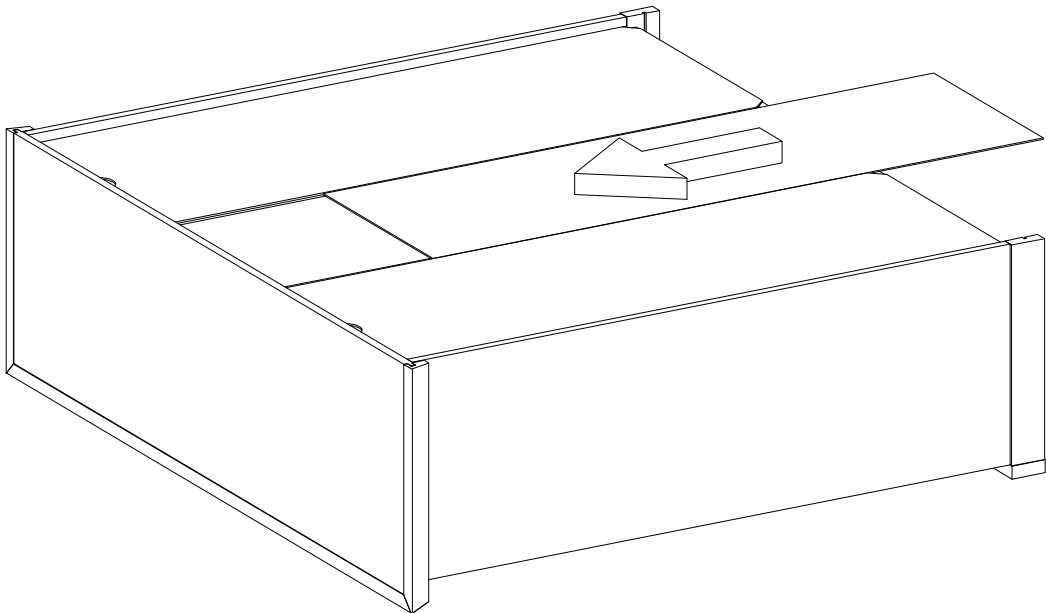

23x10x2 mm 1415 x16

UP Ø3x20 mm 1056 x16

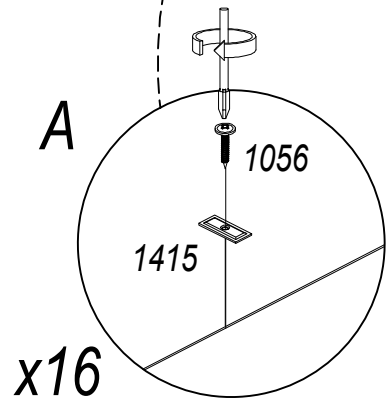
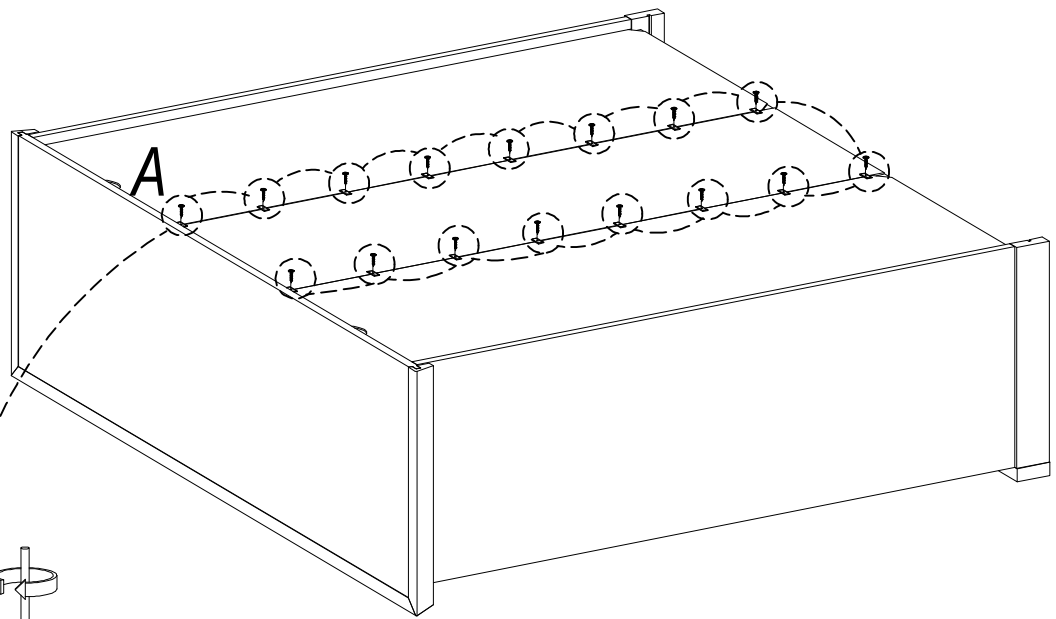
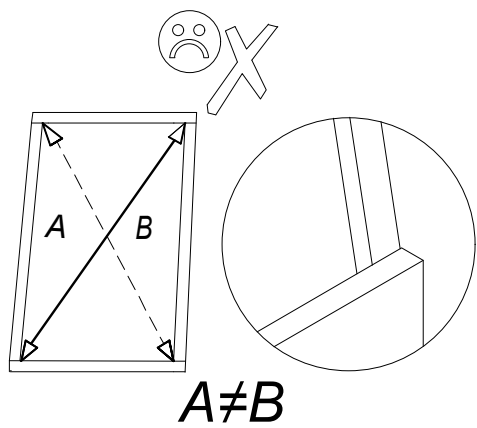
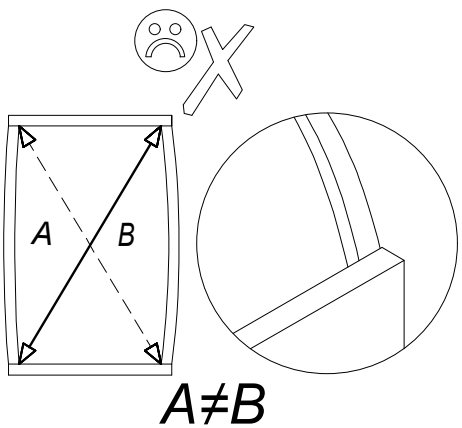
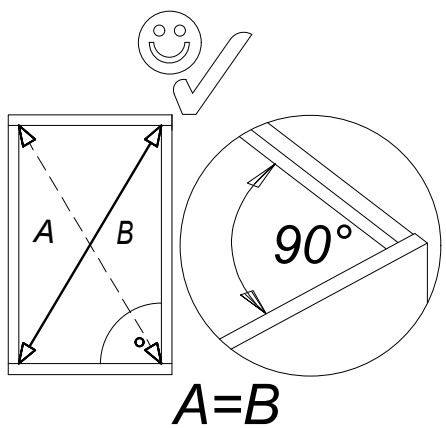

UP Ø3x20 mm 1056
x12

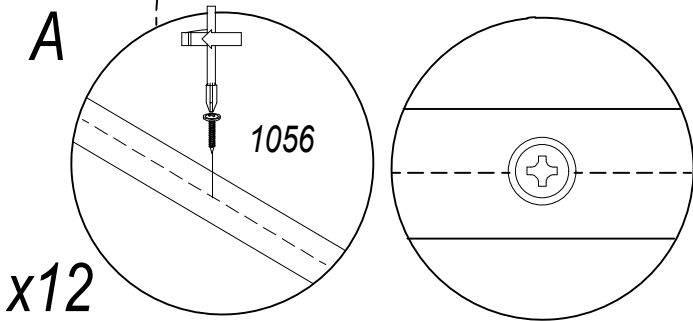
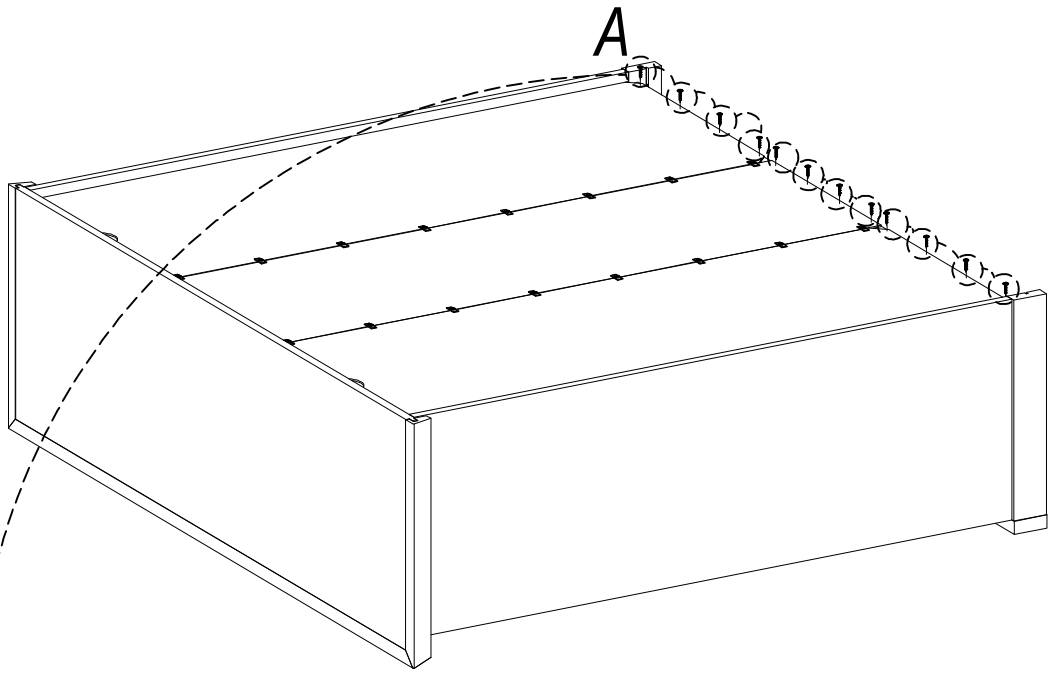
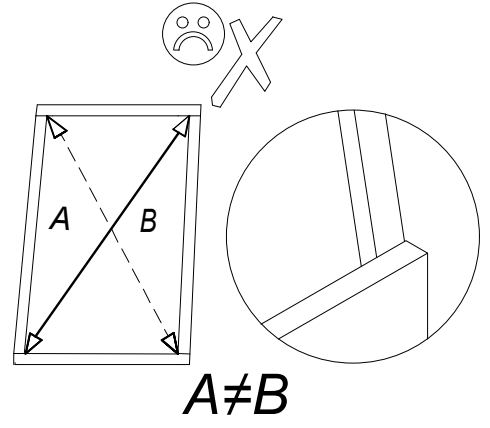
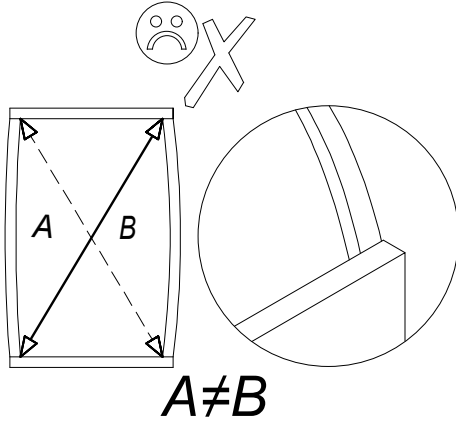
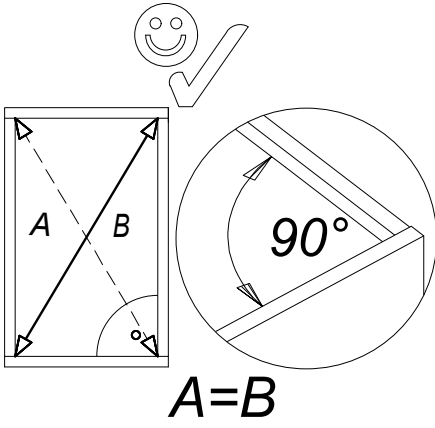

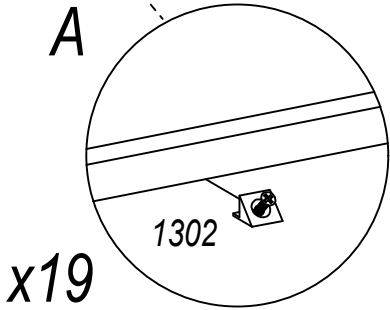
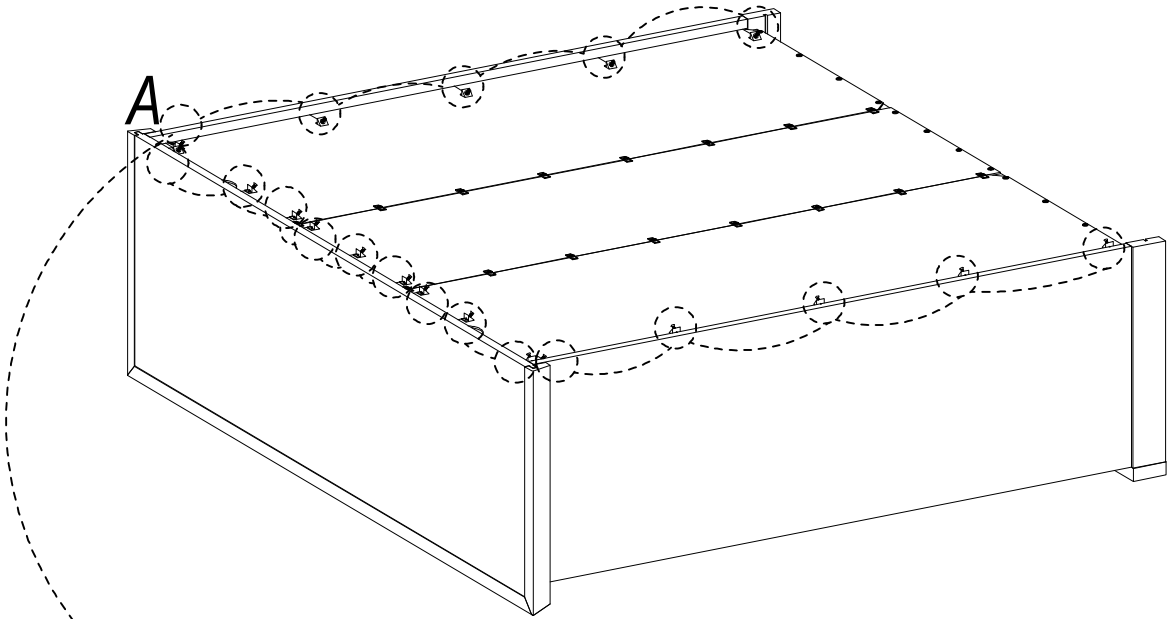
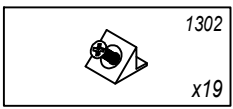

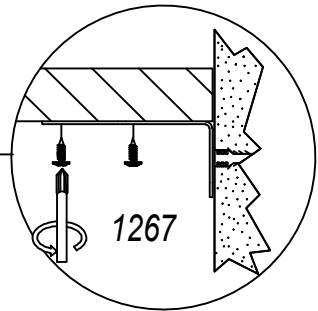
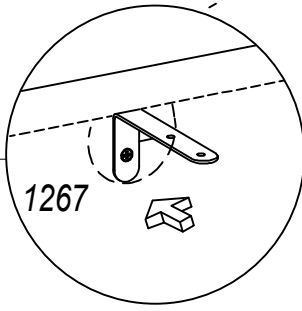
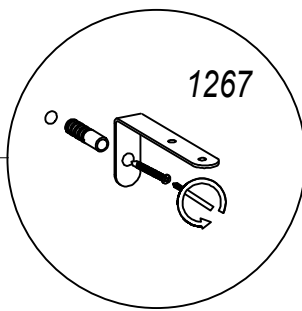
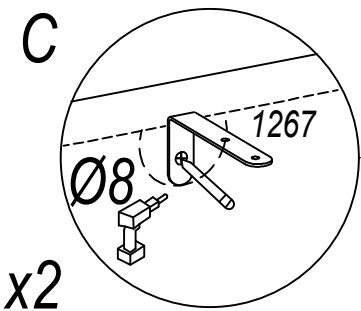
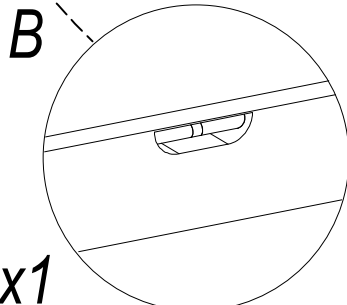
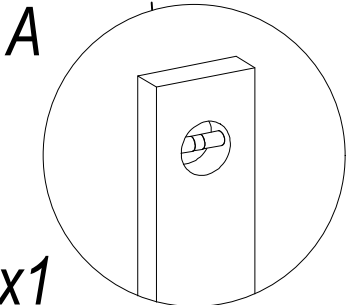
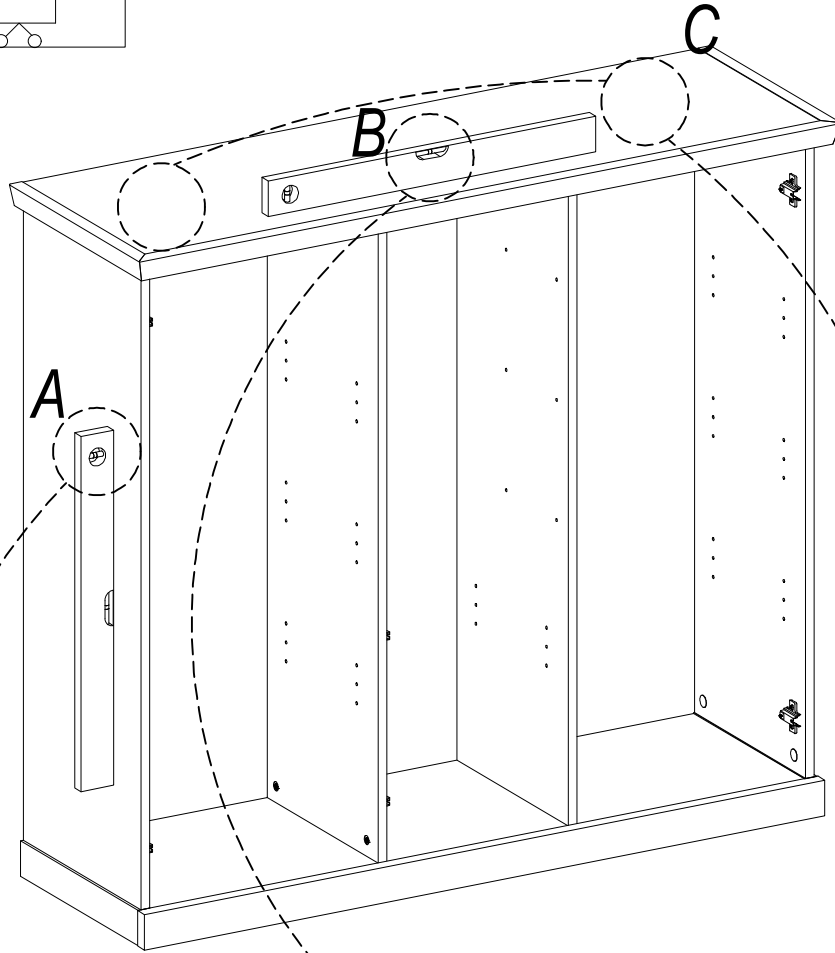
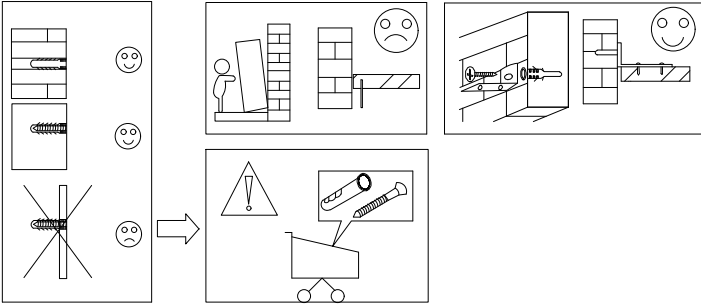
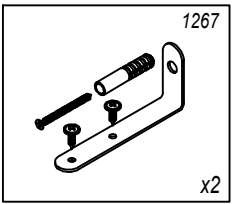

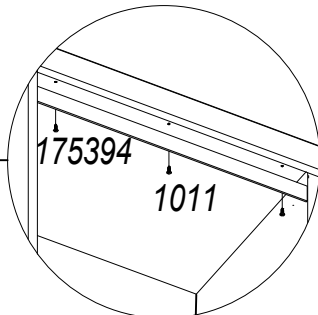
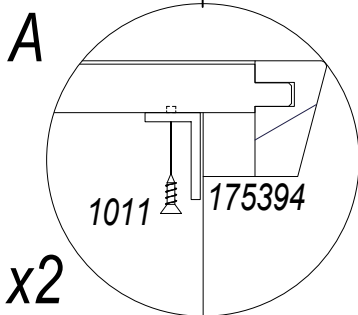
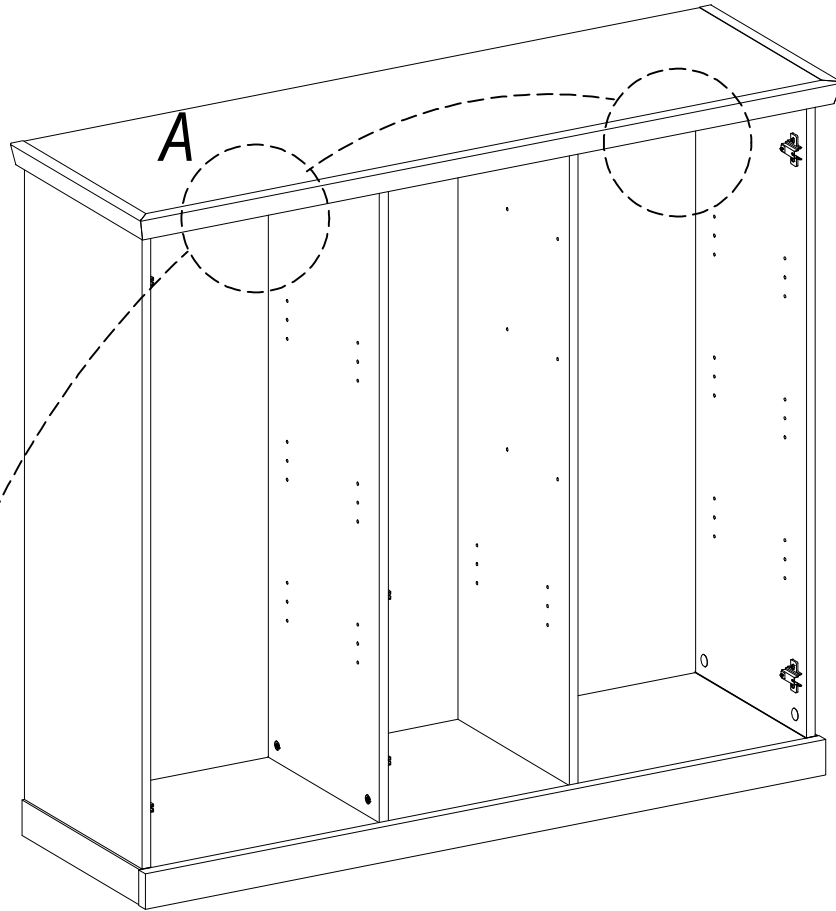
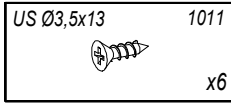
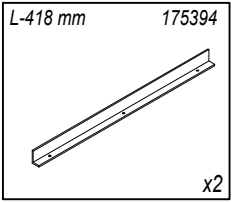

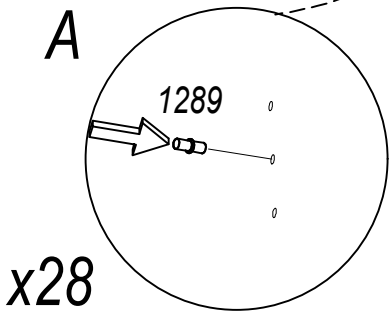
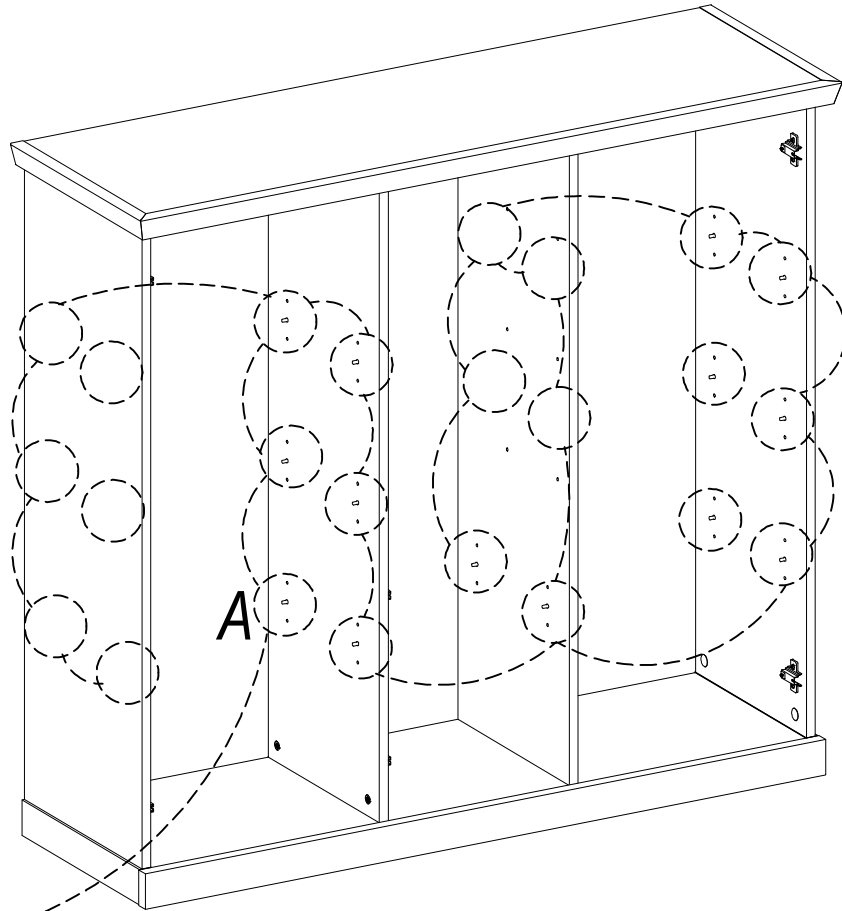
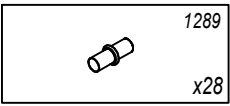

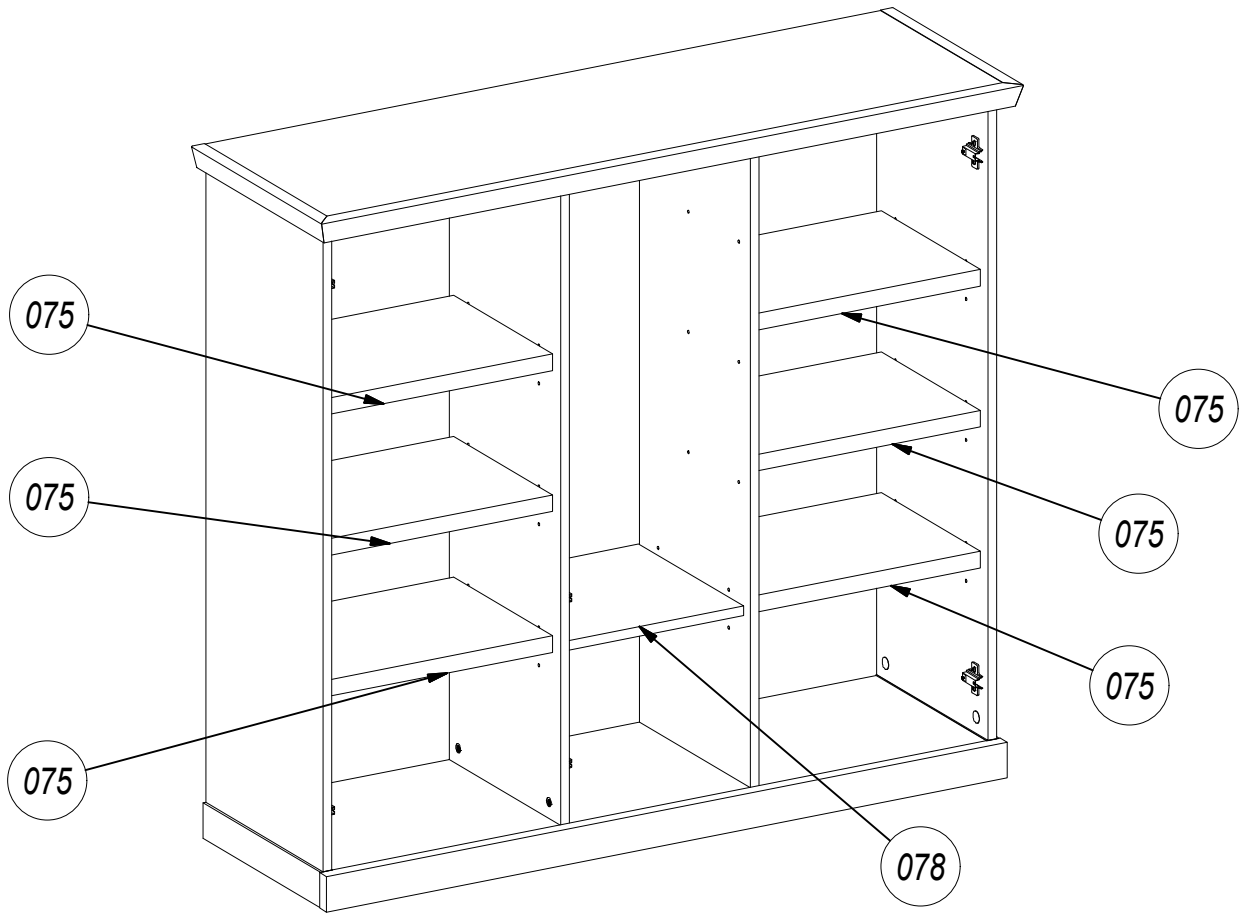

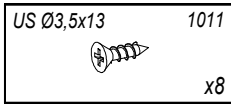
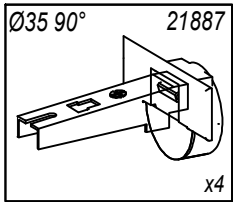

42

x2

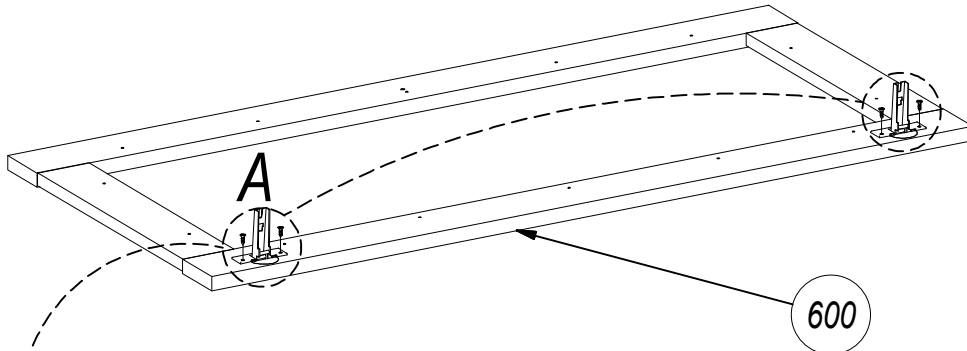

A

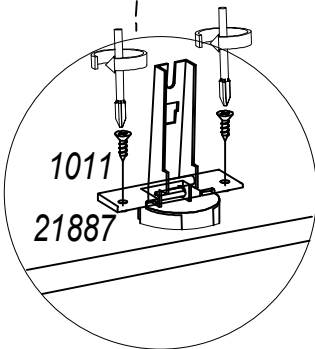

x4

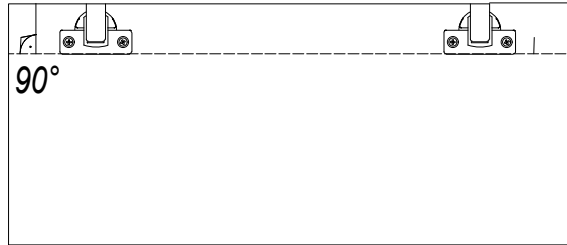

43

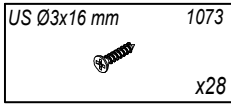
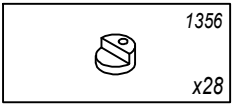

x2

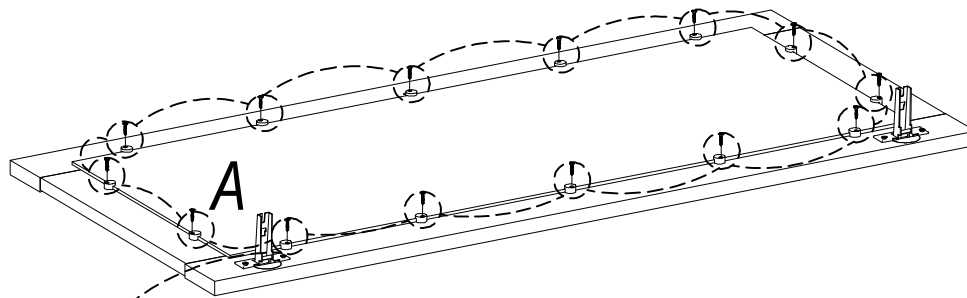

A

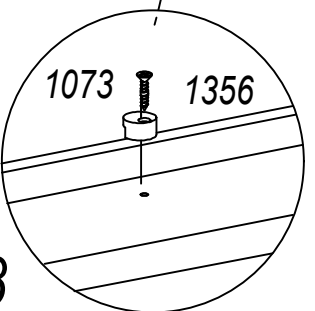

x28

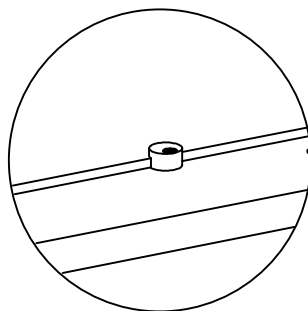

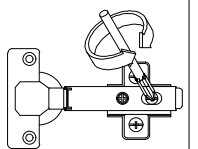
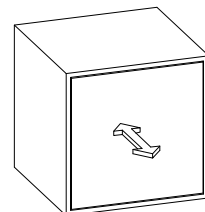
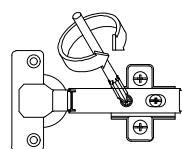
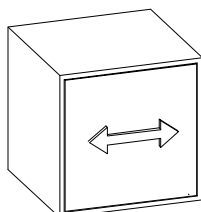
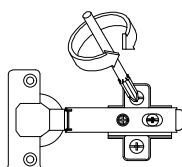
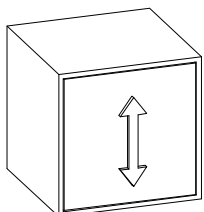
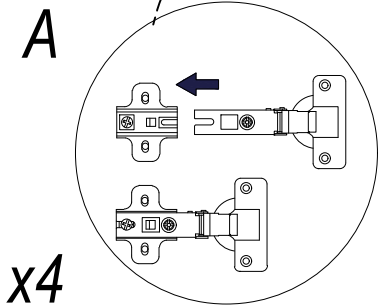
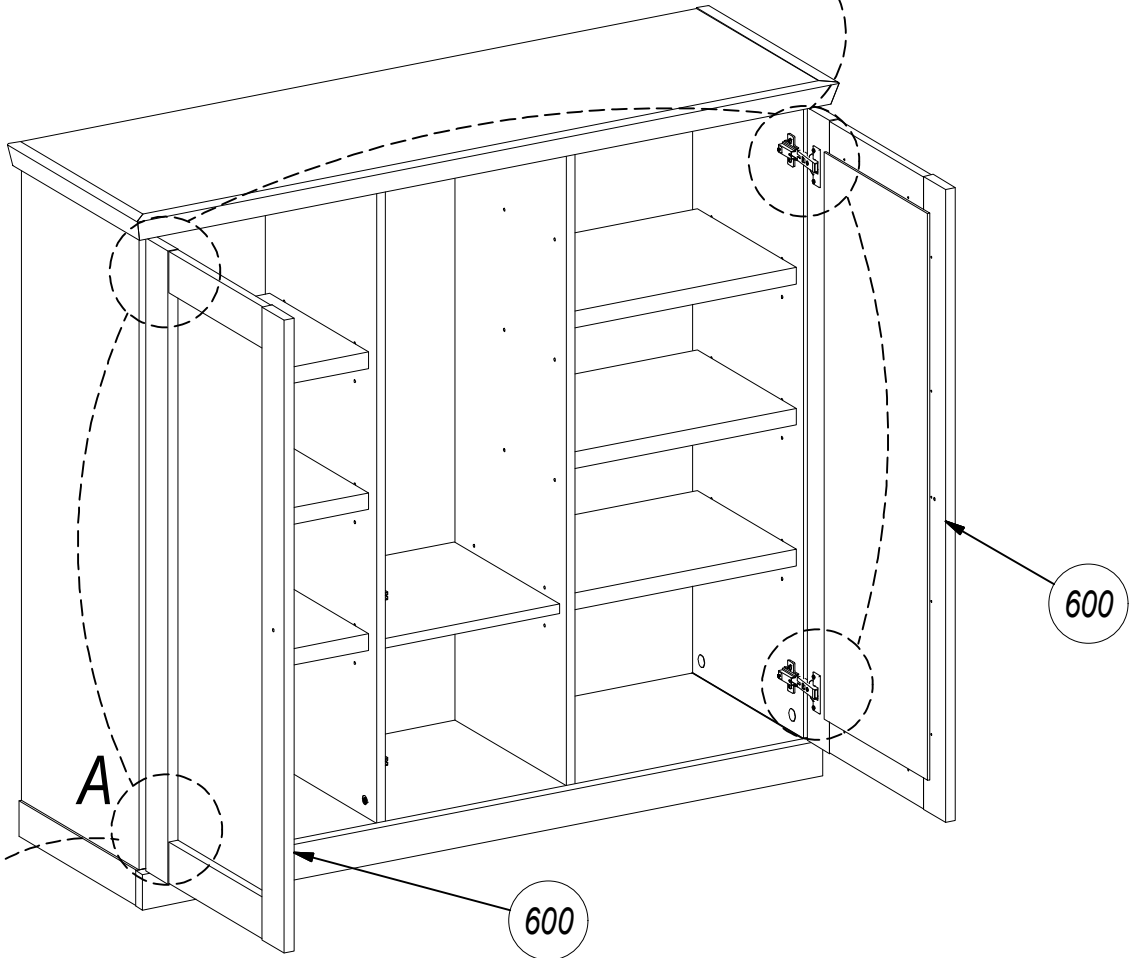
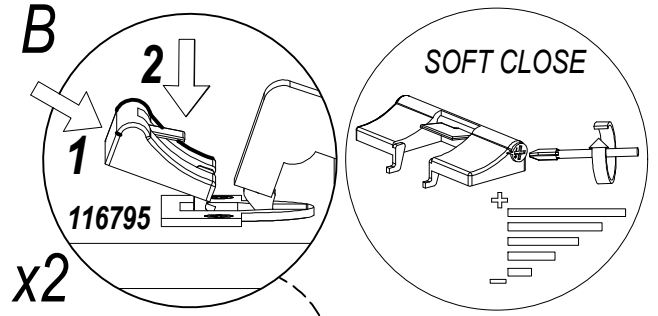
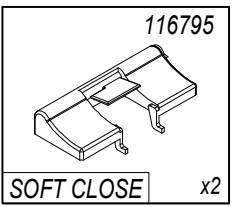

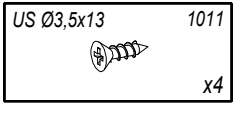
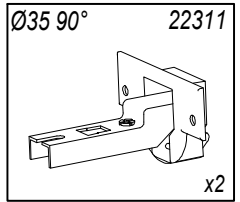



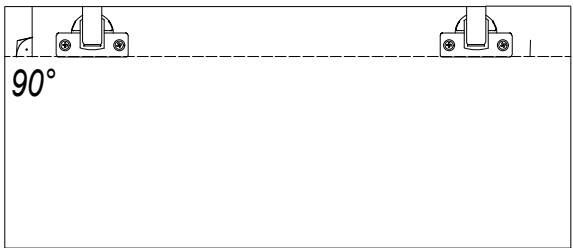
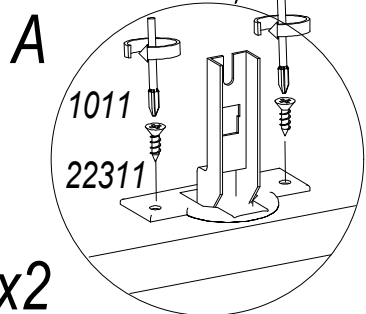
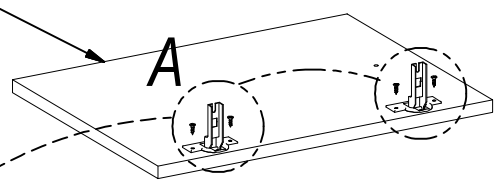

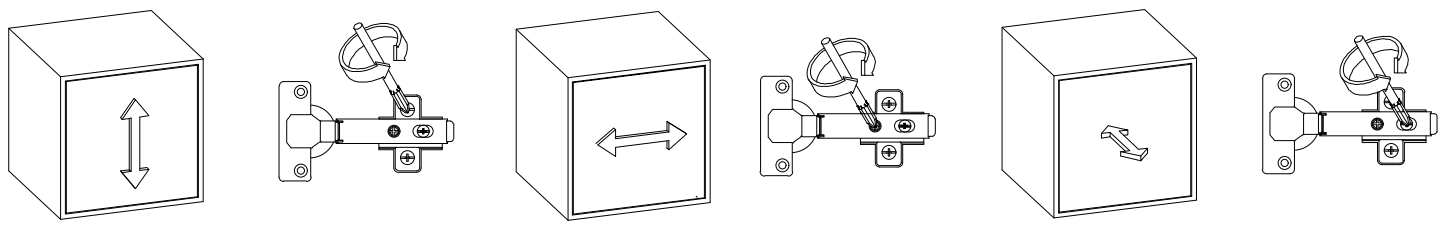
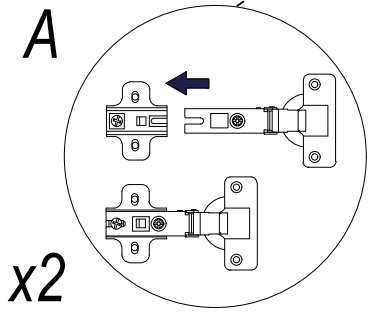
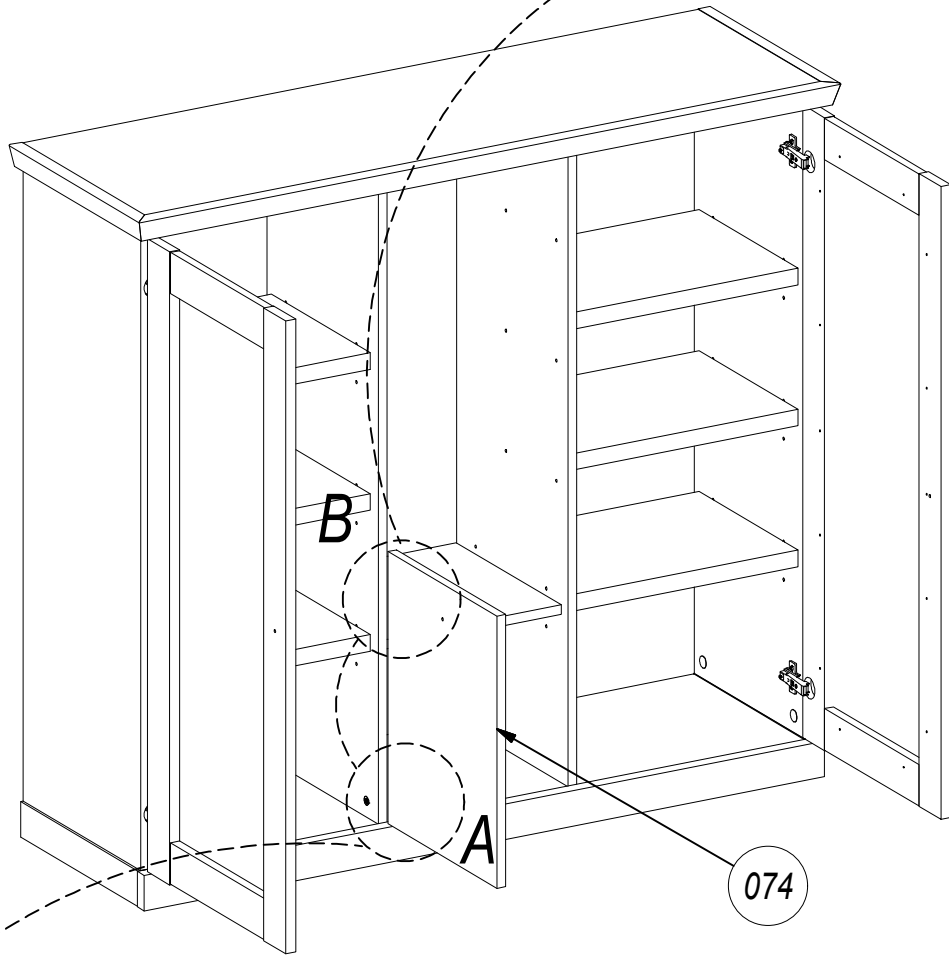
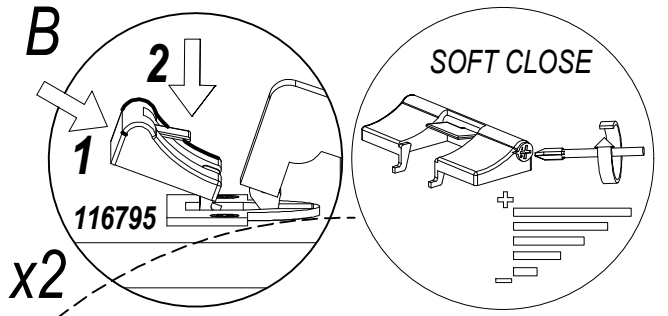
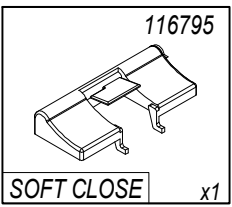
074

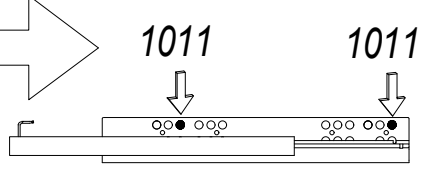
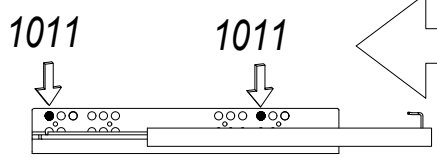
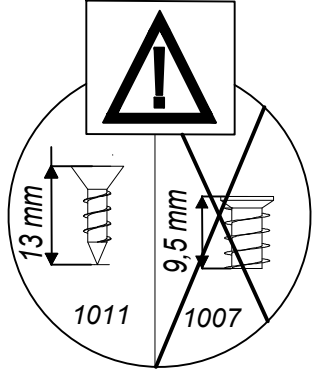
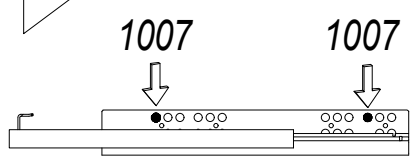
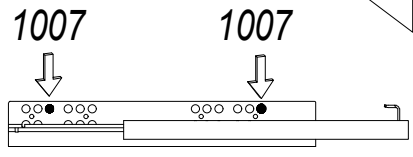
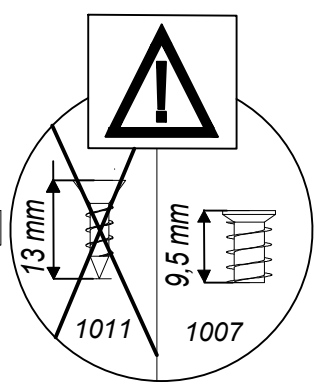
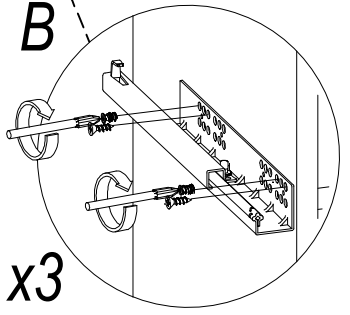
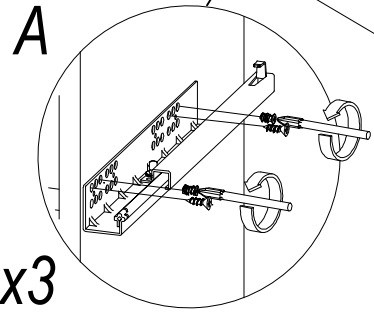
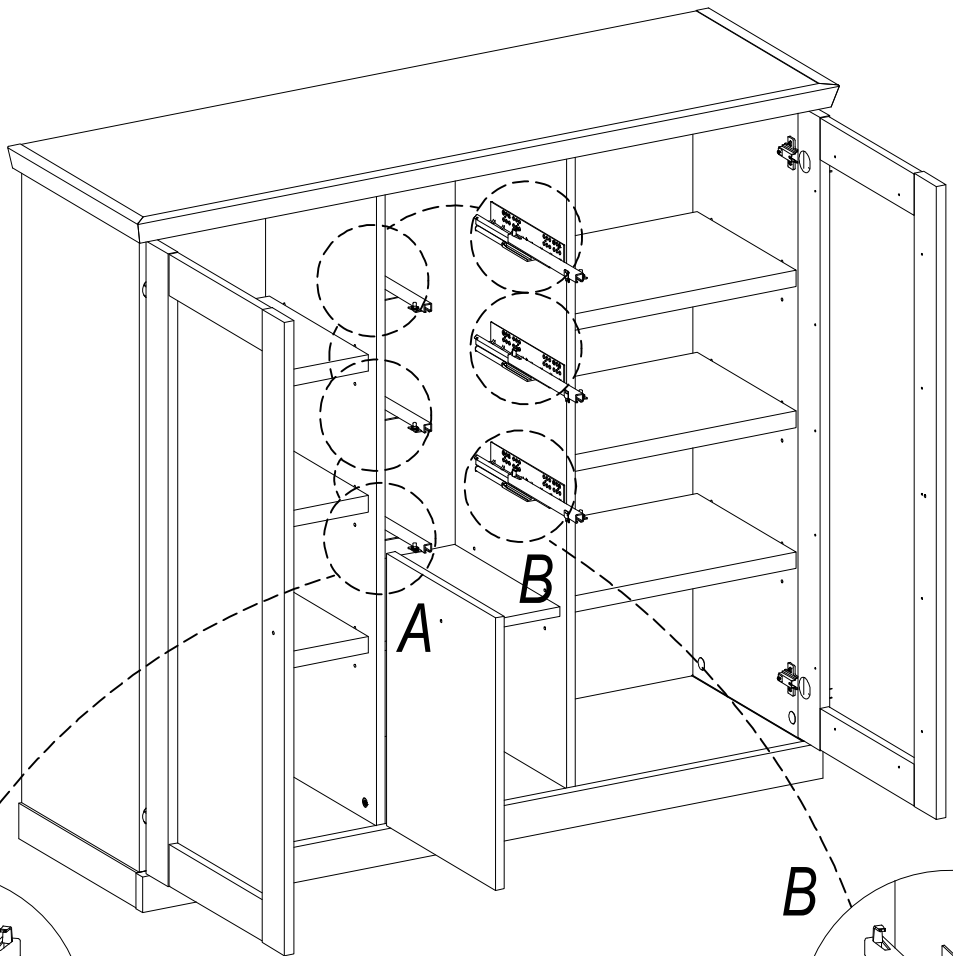
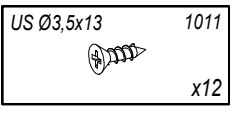
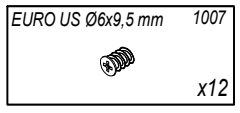
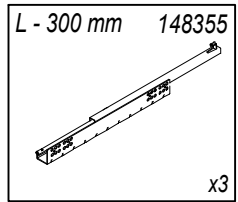
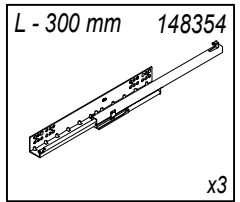





 174666 x6	 US Ø3,5x13 1011 x6	 WPM Ø4x22 mm 2549 x6
--	---	--

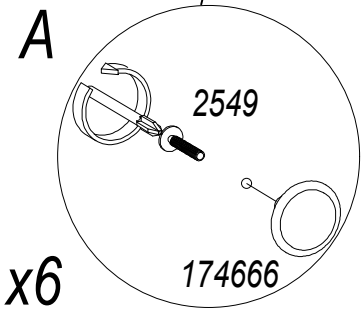
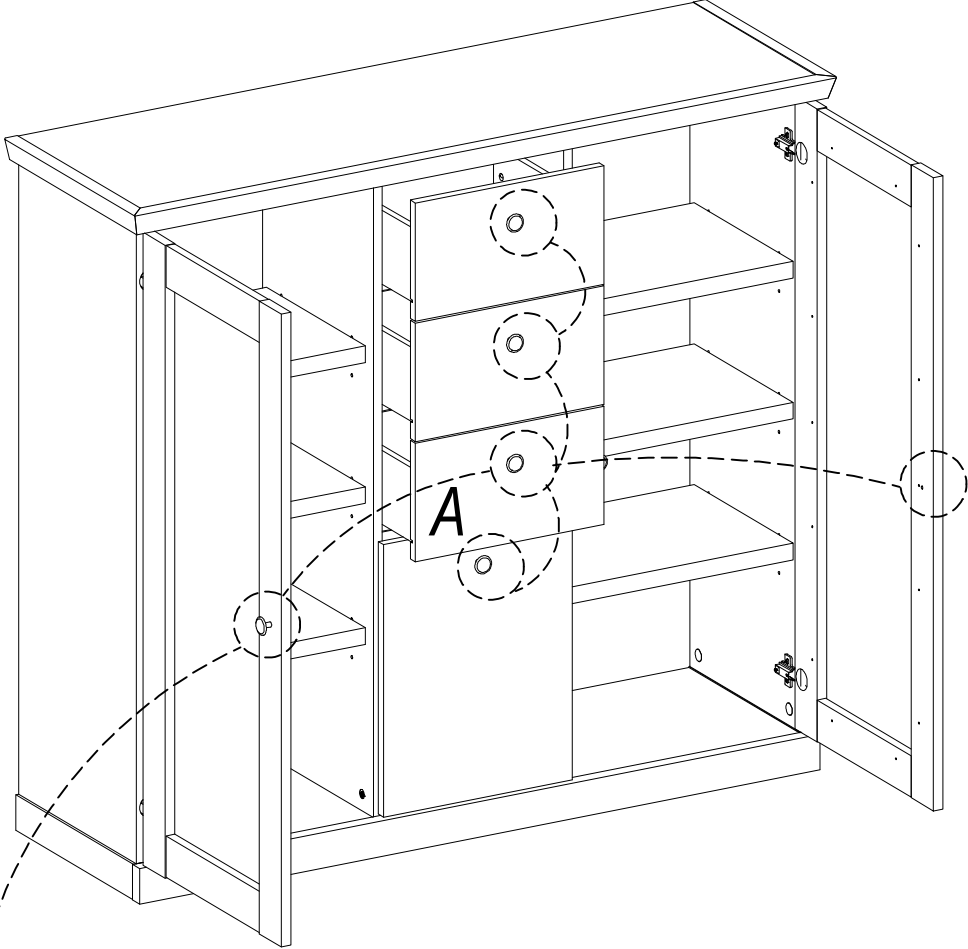
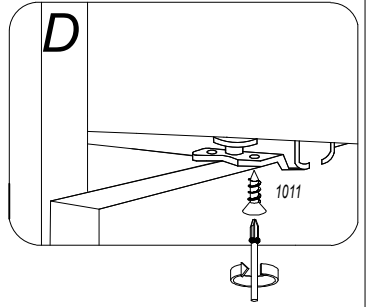
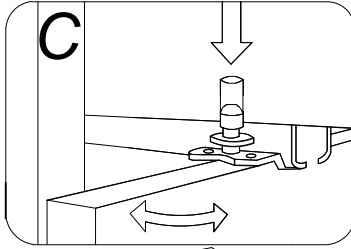
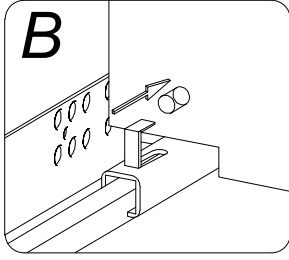
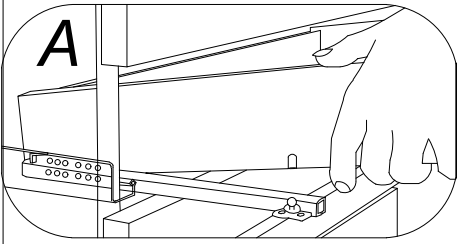

Ø20 mm 9129
x16

49

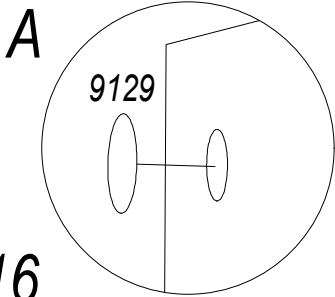
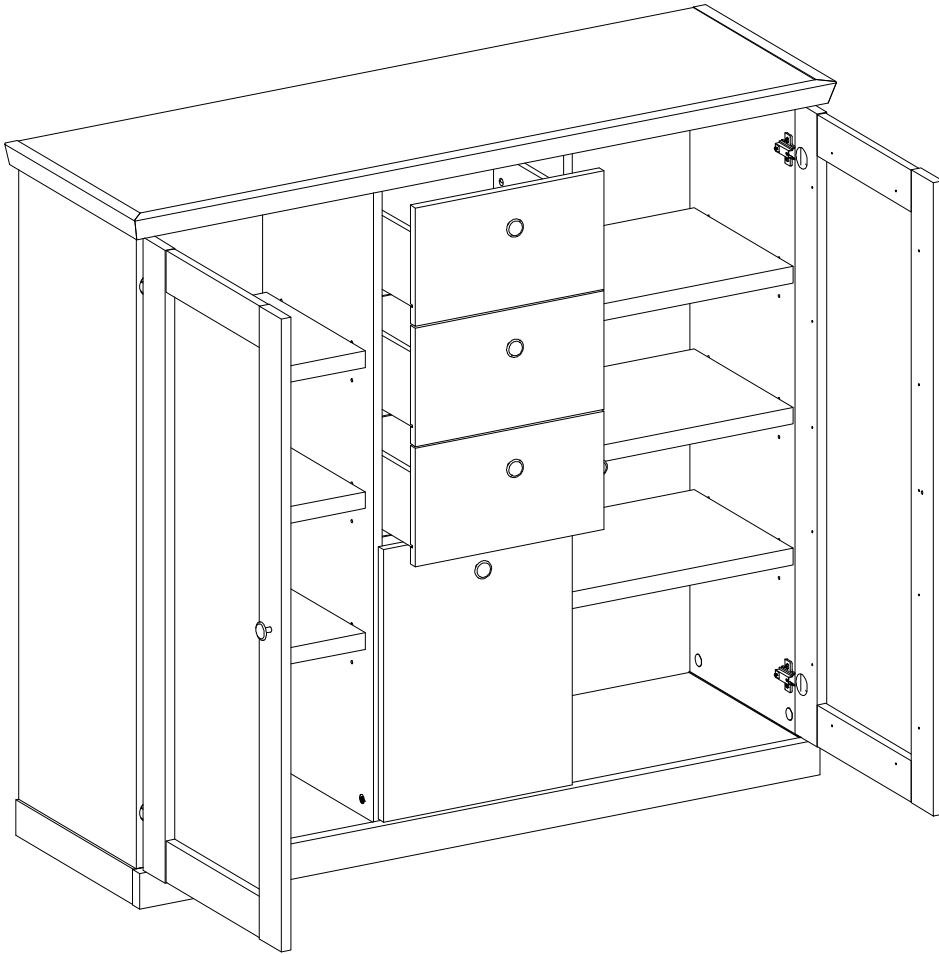

x16

LINCOLN 5S MC LN 56

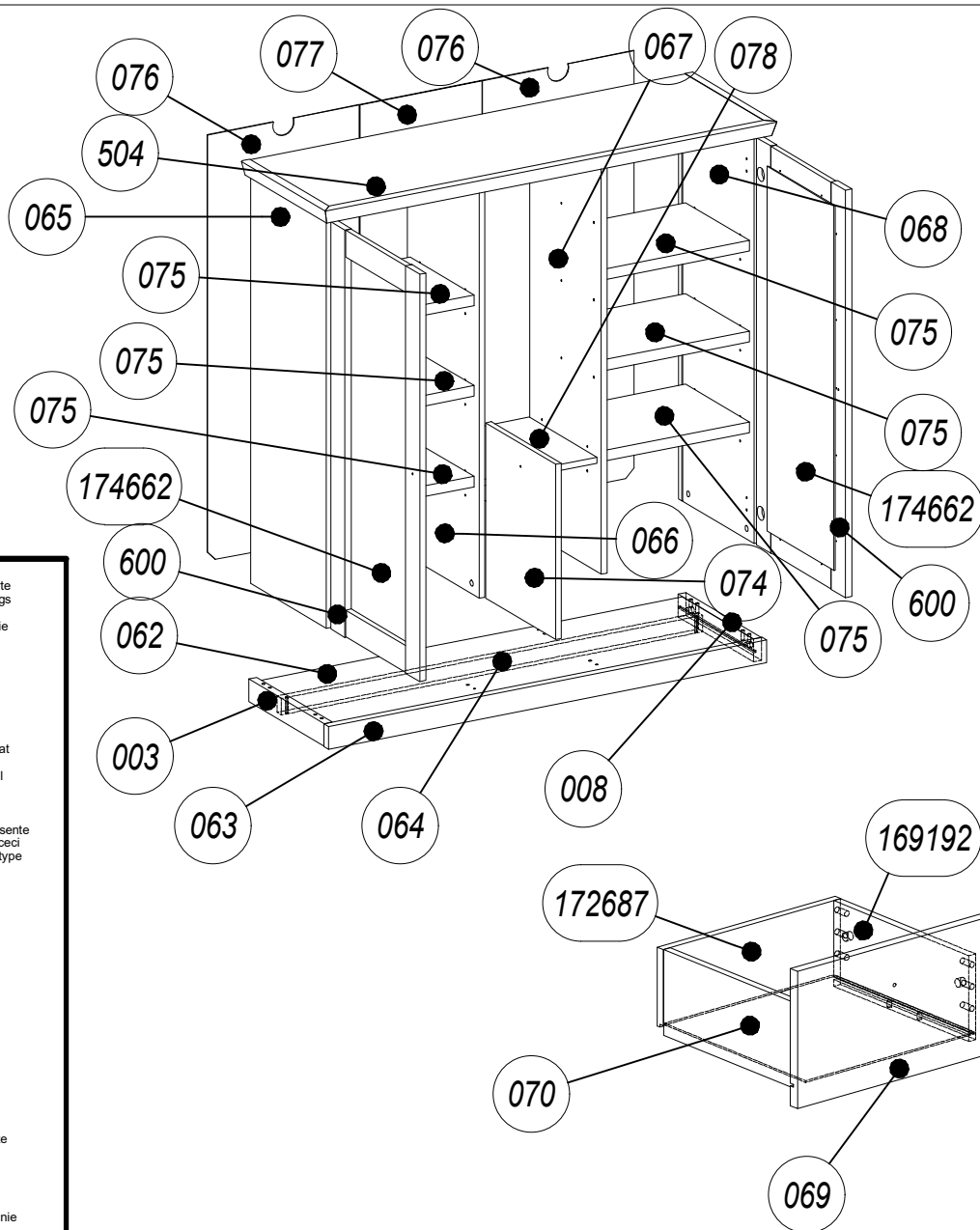

AI No.	QTY	H [MM]	W [MM]	D [MM]	PKG
003	1	373	60	22	1/2
008	1	373	60	22	1/2
062	1	1200	353	16	1/2
063	1	1247	60	22	1/2
064	1	1200	43	22	1/2
065	1	1096	373	16	1/2
066	1	1097	353	16	2/2
067	1	1097	353	16	2/2
068	1	1096	373	16	1/2
069	3	346	200	16	2/2
070	3	302	300	2,5	1/2
074	1	460	346	16	2/2
075	6	418	314	28	2/2
076	2	1118	432	2,5	1/2
077	1	1118	347	2,5	1/2
078	1	331	333	16	2/2
174662	2	957	329	4	2/2
172687	3	318	125	12	1/2
169192	6	288	125	12	1/2
504	1	1286	413	38	1/2
600	2	439	1069	18	1/2

D Unser Direktservice für Beschlagteile
Sollte Ihnen ein Beschlagteil fehlen, können Sie diese Servicekarte direkt an die untenstehende Adresse mailen. Wir können allerdings nur Beschlagteile auf diesem Wege verschicken. Sollten Sie eine andere Beanstandung auf Ihrem Möbelstück haben, so wenden sie sich bitte direkt an Ihr Möbelhaus.

GB Our direct order service for fitting
If a fitting part is missing, you can e-mail this service card directly to the address below. However, we can only send fitting parts in this way. If you have any other cause for complaint concerning your item of furniture, please contact your furniture store directly.

CZ Naše přímé služby pro kování
Chybí-li vám nějaký díl z kování, můžete tuto servisní kartu odeslat e-mailem přímo na níže uvedenou adresu. Touto cestou však můžeme zoslat jen díly kování. Pokud byste reklamovali jiný díl nábytku, obraťte se přímo na svého prodejce nábytku.

F Bien étudier la notice de montage
S'il vous manque une ferrure, veuillez envoyer directement la présente carte service à l'adresse e-mail indiquée ci-dessous. Cependant, ceci nous permet uniquement d'envoyer des ferrures. Pour tout autre type de réclamation concernant votre meuble, veuillez contacter directement votre magasin d'ameublement.

I Il nostro servizio diretto per l'ordine della ferramenta
Qualora Vi dovesse mancare un pezzo di fissaggio, allora Vi preghiamo di inviare questa carta di servizio immediatamente all'indirizzo sottostante. Possiamo inviare i pezzi di fissaggio solamente per mezzo di questo procedimento. Qualora dovesse avere qualche altra reclamazione in merito al mobile, allora Vi preghiamo di rivolgerVi direttamente al Vostro Negozio di mobili.

BG Нашата директна услуга за обков
Ако липсват части от комплекта, попълнете настоящата сервисна карта и ни я изпратете на e-mail адреса, посочен по-долу. По този начин можем да доставяме само липсващи елементи от обкова. Ако установите други дефекти по мебелите, Ви съветваме да се обрънете към мебелната къща/магазин, от който сте закупили стоката.

NL Onze directservice voor losse onderdelen
Wanneer er een onderdeel ontbreekt, kunt u deze servicekaart direct aan onderstaand e-mailadres sturen. Wij kunnen langs deze weg echter alleen beslagdelen versturen. Mocht u een ander probleem aan uw meubel hebben, verzoeken wij u contact op te nemen met uw meubeldealer.

PL Nasz bezpośredni serwis czeski montazowych
Jeżeli brakuje części koniecznych do montażu, prosimy o przesłanie nam niniejszej karty serwisowej na niżej podany adres e-mailowy. W ten sposób możemy przesłać Państwu tylko brakujące części. W przypadku innych reklamacji dotyczących mebla, prosimy zgłosić się do salonu meblowego, w którym został dokonany zakup.

HR Servis za okove
U slučaju da nedostaje neki od dijelova molimo vas da na dolje navedenu mail adresu pošaljete ovaj servisni obrazac. Na ovaj način mogu se dostaviti samo okovi. U slučaju da imate dodatne prigovore vezane uz komad namještaja molimo vas da se obratite izravno trgovini namještaja gdje je isti kupljen.

HU Direktszolgáltatunk vasalokat esetén
Ha hiányzik egy vasalat, ezt a kártyát közvetlenül elküldheti az alább található címre. Azonban csakis vasalatókat tudunk így küldeni. Amennyiben másfajta reklamáció áll fenn bútordarabját illetően, forduljon közvetlenül a bútorházhoz.

SK Náš priamy servis pre časti kovania
Ak by vám chýbala niekaka časť kovania, môžete poslať túto servisnú kartu poslať e-mailom na nižšie uvedenú adresu. Díly kovania vieme poslať iba týmto spôsobom. Ak by ste mali inú reklamáciu ohľadom Vašho nábytku, obráťte sa priamo na Vašu predajňu nábytku.

SLO Naše direktne uslužne storitve za okovje
Ce vam manjka kakšno okovje, lahko to servisno kartico pošljete po e-pošti direktno na spodnji naslov. Po tej poti vam lahko pošljemo samo okovje. Če želite reklamirati kakšen drug del pohištva, se obrnite neposredno na vašo trgovino pohištva.

RO Service-ul nostru direct pentru feronerie
In cazul in care va lipseste o piesa de feronerie puteti să trimiteti direct acest card de service prin e-mail la adresa de mai jos. Noi nu putem expedia piese de feronerie decât pe această cale. Dacă aveți o altă reclamație referitoare la piesa de mobilier, atunci vă rugăm să vă adresați direct la magazinul dvs. de mobilă.

RUS Наш прямой сервис для поставок фурнитуры
Если окажется, что Вам не хватает того или иного элемента фурнитуры, Вы можете отправить сервисную карту по факсу непосредственно на нижеприведенный адрес электронной почты. Однако, таким образом мы можем переслать лишь фурнитуру. Если же у Вас возникнут иные претензии относительно приобретенной мебели, пожалуйста, обращайтесь непосредственно в организацию, осуществившую продажу.

S Vår direktservice för beslagsdelar
Om du saknar en beslagsdel kan du skicka detta servicekort direkt till e-postadressen som anges nedan. Tank på att detta är den enda möjligheten att skicka beslagsdelar till dig. Om du vill reklamera din möbel av en annan anledning måste du kontakta ditt möbelhus direkt.

ES Nuestro servicio directo para accesorios
Si le falta algún accesorio, puede enviar esta tarjeta de servicio directamente a la siguiente dirección. No obstante, por este método solo podemos enviar accesorios. Si tiene alguna otra objeción sobre su mueble, consulte directamente con su mueblería.

TR Donatılar için doğrudan servisimiz
Bir donatınız eksikse bu servis kartını doğrudan aşağıda bulunan adrese doğrudan mail yazabilirsiniz. Sadece bu yolla donatılar gönderiliriz. Mobilyanızda başka şikayetleriniz varsa lütfen doğrudan mobilya satıcınıza danışın.

LINCOLN 5S MC LN 56

Unser Direktservice für Beschlagteile

Should you be missing a fitting part, you can e-mail this service card directly to the address below. However, we can only send fitting parts in this way. If you have any other cause for complaint concerning your item of furniture, please contact your furniture store directly.

Our direct order service for fitting

Si il vous manque une ferrure, veuillez envoyer directement la présente carte service à l'adresse e-mail indiquée ci-dessous. Cependant, ceci nous permet uniquement d'envoyer des ferrures. Pour tout autre type de réclamation concernant votre meuble, veuillez contacter directement votre magasin d'ameublement.

Naše přímé služby pro kování

Čtyřlístek vám nejkdy dle z kování, můžete tuto servisní kartu odeslat e-mailem přímo na níže uvedenou adresu. Touto cestou však můžeme zoslat jen díly kování. Pokud byste reklamovali jiný díl nábytku, obraťte se přímo na svého prodejce nábytku.

Bien étudier la notice de montage

Il nostro servizio diretto per l'ordine della ferramenta

Qualora Vi dovesse mancare un pezzo di fissaggio, allora Vi preghiamo di inviare questa carta di servizio immediatamente all'indirizzo sottostante. Possiamo inviare i pezzi di fissaggio solamente per mezzo di questo procedimento. Qualora dovreste avere qualche altra reclamazione in merito al mobile, allora Vi preghiamo di rivolgerVi direttamente al Vostro Negozio di mobili.

Нашата директна услуга за обко

Ако липсват части от комплекта, попълнете настоящата сервисна карта и ни я изпратете на e-mail адреса, посочен по-долу. По този начин можем да доставяме само липсващи елементи от обкова. Ако установите други дефекти по мебелите, Ви съветваме да се обвърнете към мебелната къща/магазин, от който сте закупили стоката.

Onze directservice voor losse onderdelen

Wanneer er een onderdeel ontbreekt, kunt u deze servicekaart direct aan onderstaand e-mailadres sturen. Wij kunnen langs deze weg echter alleen beslagdelen versturen. Mocht u een ander probleem aan uw meubel hebben, verzoeken wij u contact op te nemen met uw meubeldealer.

Nasz bezpośredni serwis części montażowych

Jeżeli brakuje części koniecznych do montażu, prosimy o przesłanie nam niniejszej karty serwisowej na niżej podany adres e-mailowy. W ten sposób możemy przesłać Państwu tylko brakujące części. W przypadku innych reklamacji dotyczących mebla, prosimy zgłosić się do salonu meblowego, w którym został dokonany zakup.

Servis za okove

U slučaju da nedostaje neki od dijelova molimo vas da na dolje navedenu mail adresu pošaljete ovaj servisni obrazac. Na ovaj način mogu se dostaviti samo okovi. U slučaju da imate dodatne prigovore vezane uz komad namještaja molimo vas da se obratite izravno trgovini namještaja gdje je isti kupljen.

Direktszolgáltatunk vasalatok esetén

Ha hiányzik egy vasalat, ezt a Kártyát közvetlenül elküldheti az alább található címre. Azonban csakis vasalatoskat tudunk így küldeni. Amennyiben másfajta reklamáció áll fenn bútorárbájáért illetően, forduljon közvetlenül a bútorházhöz.

Náš priamy servis pre časti kovania

Ak by vám chýbala nejaká časť kovania, môžete poslať túto servisnú kartu poslať e-mailom na nižšie uvedené adresu. Díly kovania vieme poslať iba týmto spôsobom. Ak by ste mali inú reklamáciu ohľadom Vášho nábytku, obráťte sa priamo na Vašu predajňu nábytku.

Naše direktno uslužne storitve za okovje

Ce vam manjka kakšno okovje, lahko to servisno kartico pošljete po e-pošti direktno na spodnji naslov. Po tej poti vam lahko pošljemo samo okovje. Če želite reklamirati kakšen drug del pohištva, se obrnite neposredno na vašo trgovino pohištva.

Service-ul nostru direct pentru feronerie

In cazul in care va lipseste o piesa de feronerie puteti sa trimiteți direct acest card de service prin e-mail la adresa de mai jos. Noi nu putem expedia piese de feronerie decât pe această cale. Dacă aveți o altă reclamație referitoare la piesa de mobilier, atunci vă rugăm să vă adresați direct la magazinul dvs. de mobilă.

Наш прямой сервис для поставок фурнитуры

Если окажется, что Вам не хватает того или иного элемента фурнитуры, Вы можете отправить сервисную карту по факсу непосредственно на нижеприведенный адрес электронной почты. Однако, таким образом мы можем переслать лишь фурнитуру. Если же у Вас возникнут иные претензии относительно приобретенной мебели, пожалуйста, обращайтесь непосредственно в организацию, осуществившую продажу.

Vår directservice för beslagsdelar















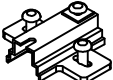







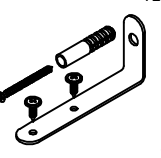

Om du saknar en beslagsdel kan du skicka detta servicekort direkt till e-postadressen som anges nedan. Tänk på att detta är den enda möjligheten att skicka beslagsdelar till dig. Om du vill reklamera din möbel av en annan anledning måste du kontakta ditt möbelhus direkt.

Nuestro servicio directo para accesorios

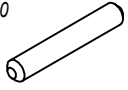
Si le falta algún accesorio, puede enviar esta tarjeta de servicio directamente a la siguiente dirección. No obstante, por este método solo podemos enviar accesorios. Si tiene alguna otra objeción sobre su mueble, consulte directamente con su mueblería.

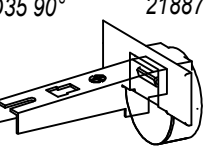
Donatilar için doğrudan servisimiz

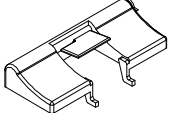
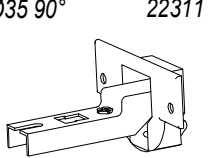
Bir donatılar eksikse bu servis kartını doğrudan aşağıda bulunan adrese doğrudan mail yazabilirsiniz. Sadece bu yöllä donatıları gönderiliriz. Mobilyanızda başka şikayetleriniz varsa lütfen doğrudan mobilya satıcınıza danışın.

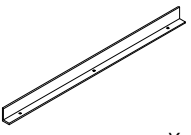
 1007	 1011	 148355	 148354
X...	X...	X...	X...
 23515	 1018	X...	X...
X...	X...	X...	X...
 11809	 123894	 76082	 10835
X...	X...	X...	X...
 127314	 127317	 1289	 1305
X...	X...	X...	X...
 1302	 1056	 1415	 1267
X...	X...	X...	X...
 18264	 1272	 9129	X...
X...	X...	X...	X...
 174693	 21887	 1356	 1073
X...	X...	X...	X...
 116795	 22311	 174666	 2549
X...	X...	X...	X...
SOFT CLOSE	X...		
 175394	X...		
X...	X...		

