

ASSEMBLY INSTRUCTION

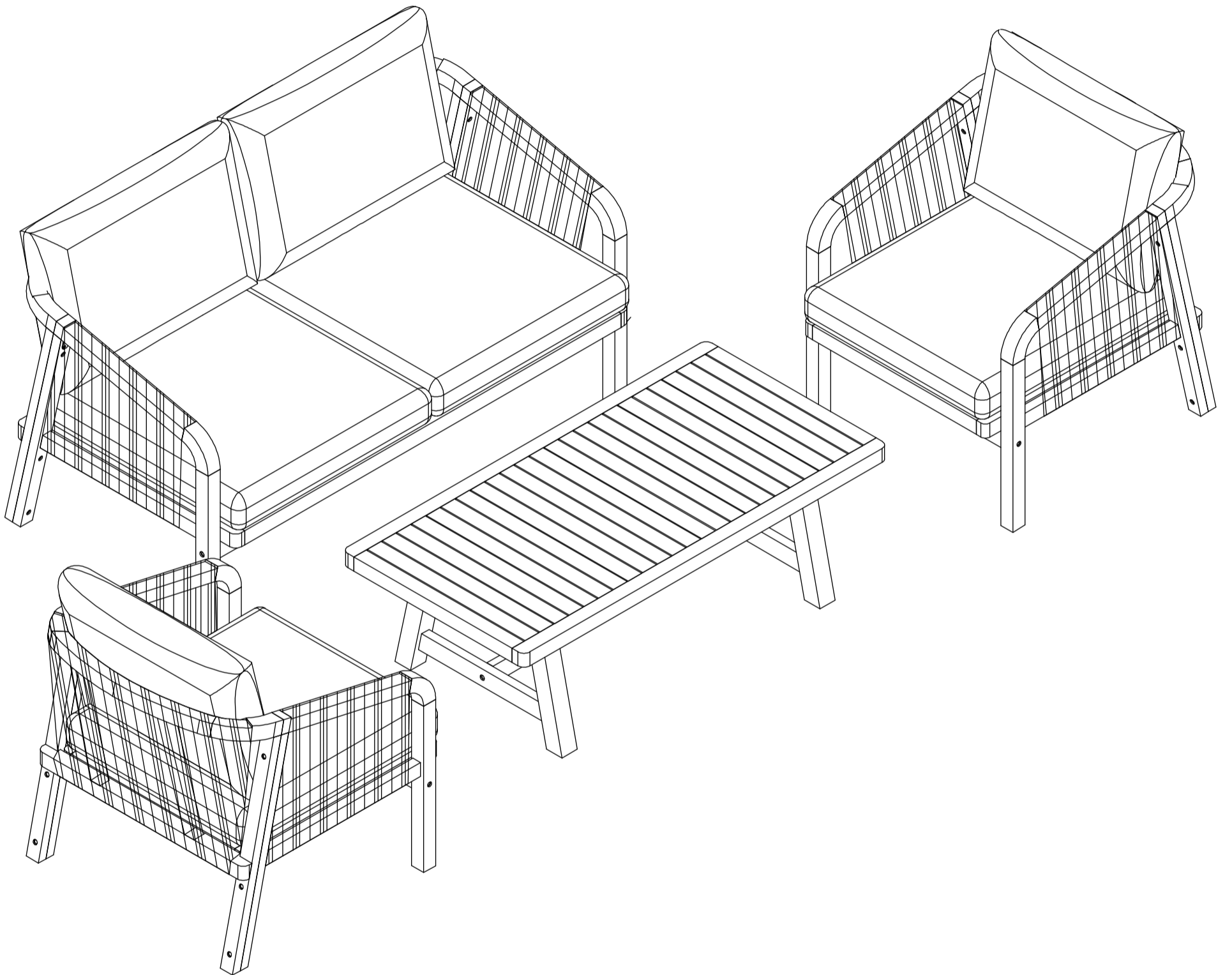

ASSEMBLY INSTRUCTION

A | 3pcs

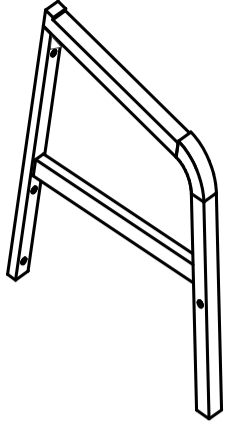

B | 3pcs

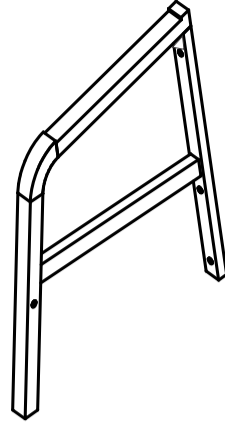

C | 2pcs

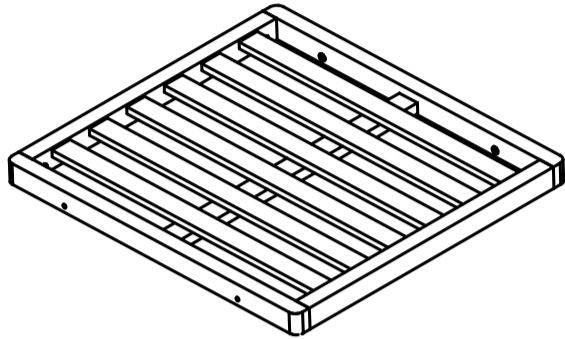

D | 2pcs

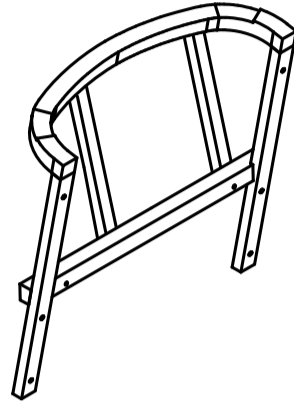

E | 1pc

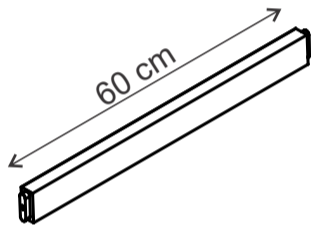

F | 1pc

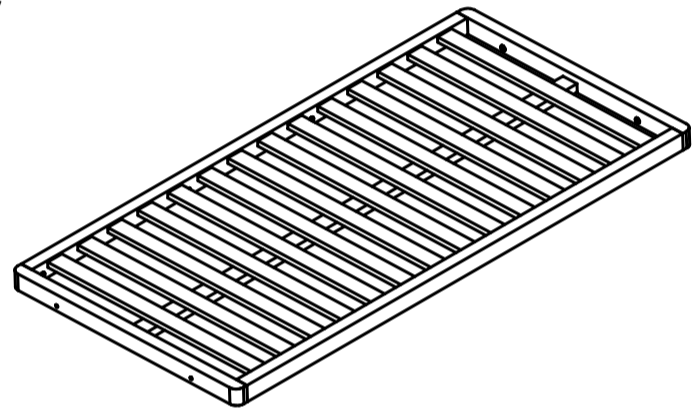

G | 1pc

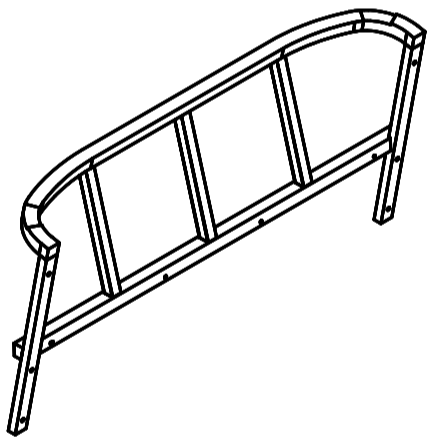

H | 1pc

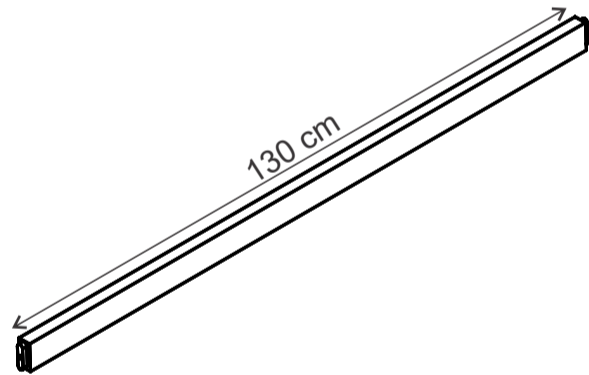

I | 1pc

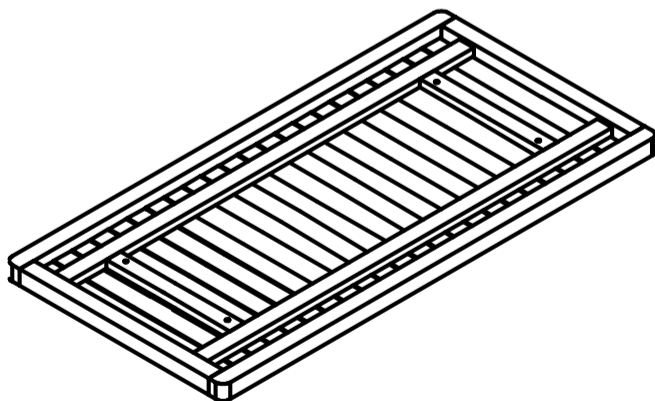

J | 2pcs

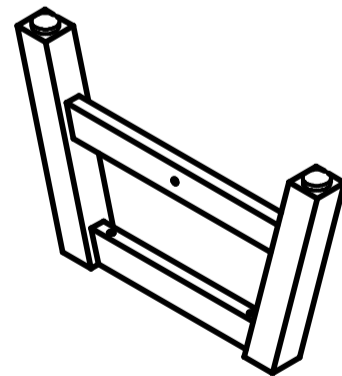

ASSEMBLY INSTRUCTION

K | 2pcs

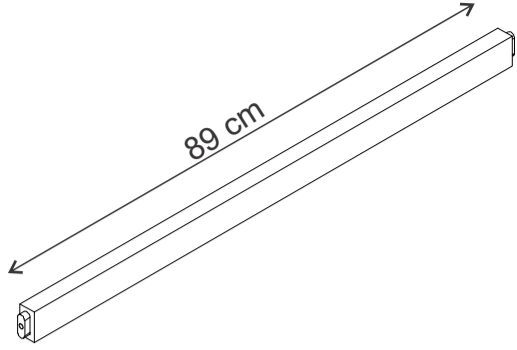

L | 2pcs

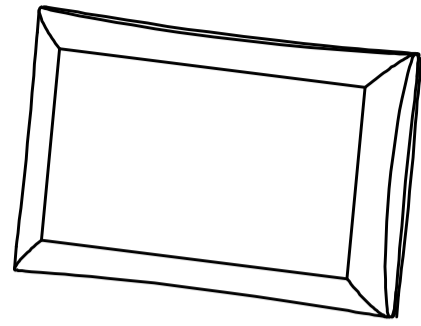

M | 2pcs

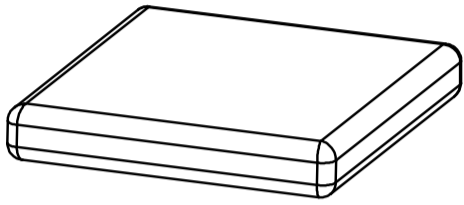

N | 2pcs

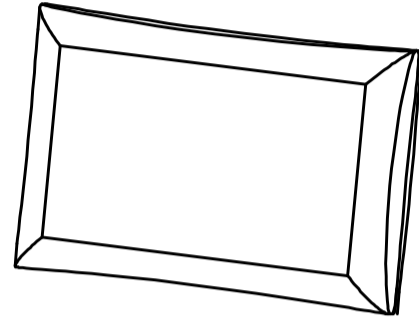

O | 2pcs

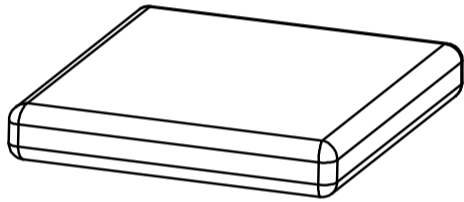

① 6pcs



BOLT M6x70 - NUT M6

② 4pcs



BOLT M6x60

③ 10pcs



BOLT M6x50

④ 12pcs



BOLT M6x40

⑤ 18pcs



BOLT M6x30 - CAP M6x15

⑥ 2pcs



BOLT M6x15

⑦ 4pcs



VIS M6x50

⑧ 4pcs

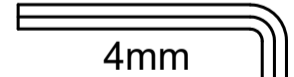

ALLEN KEY

ASSEMBLY INSTRUCTION

1

X2

Tighten bolts

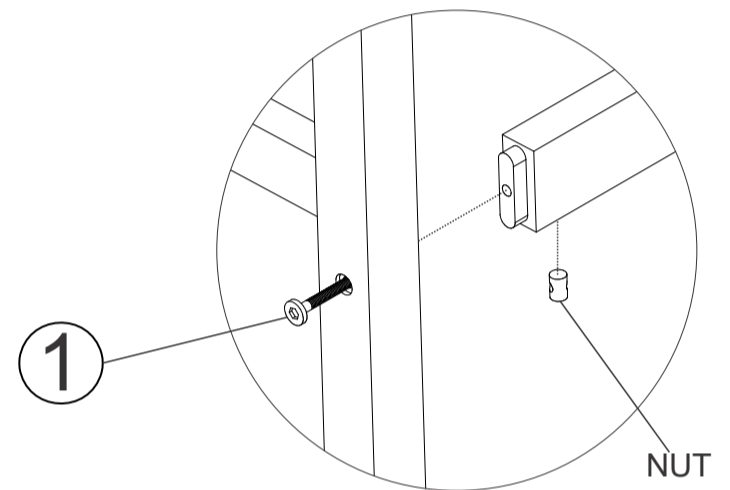
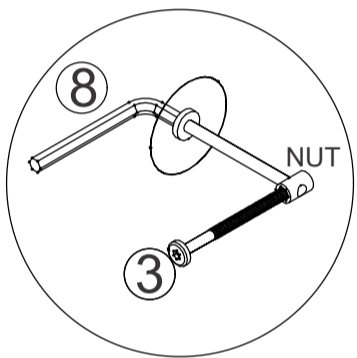
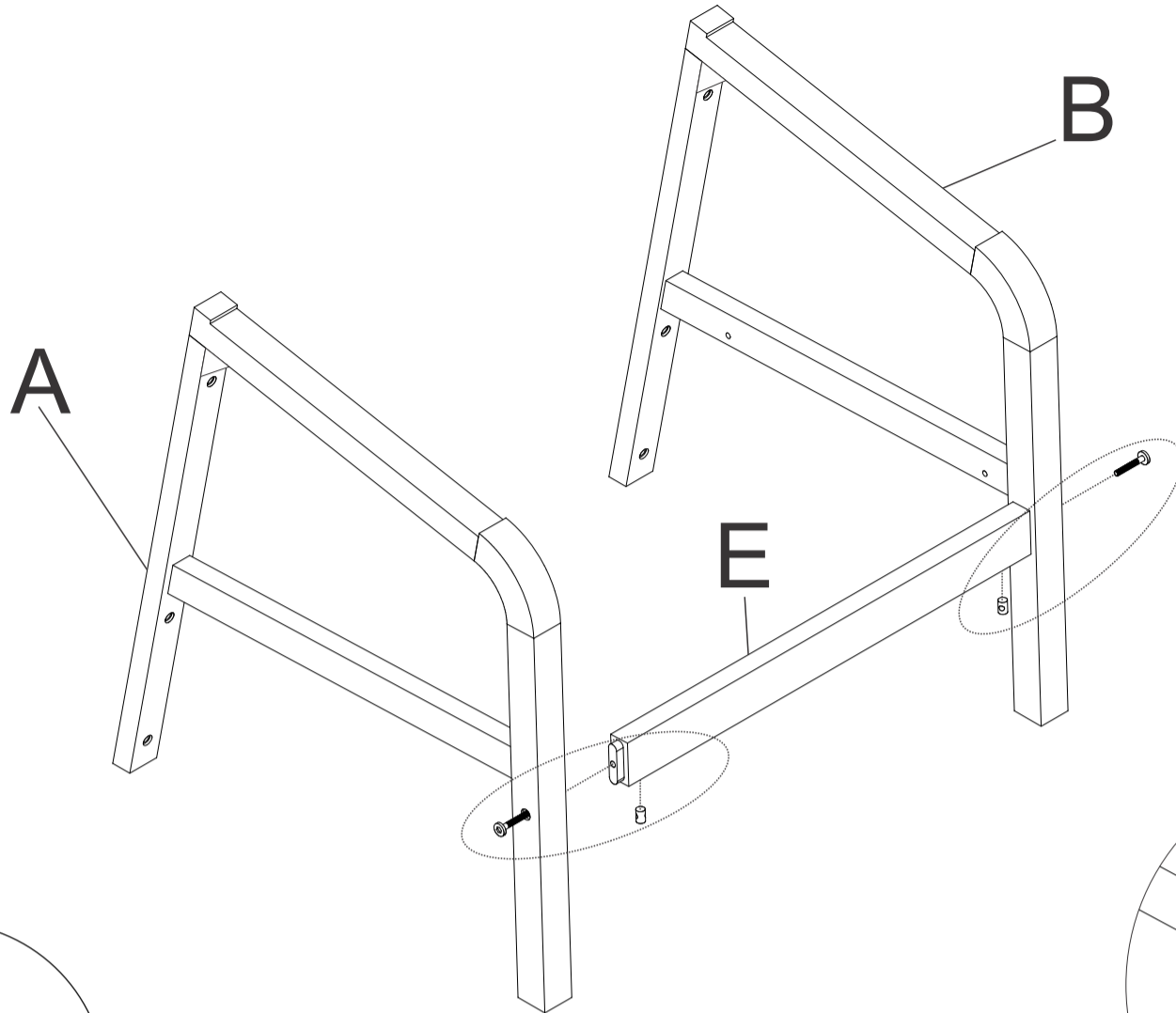

2

X2

Tighten bolts

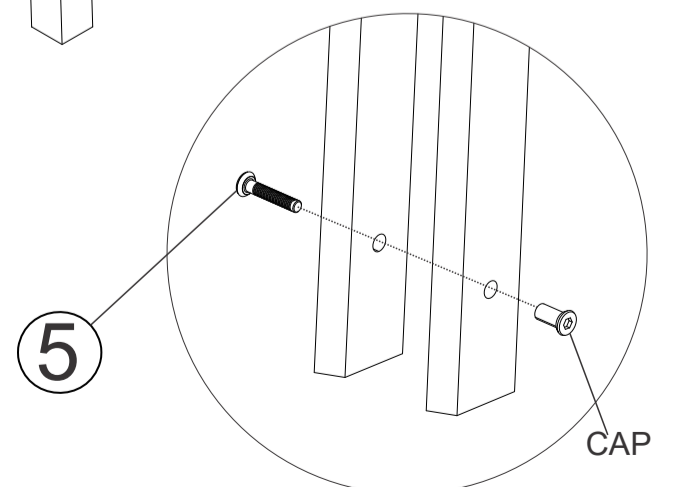
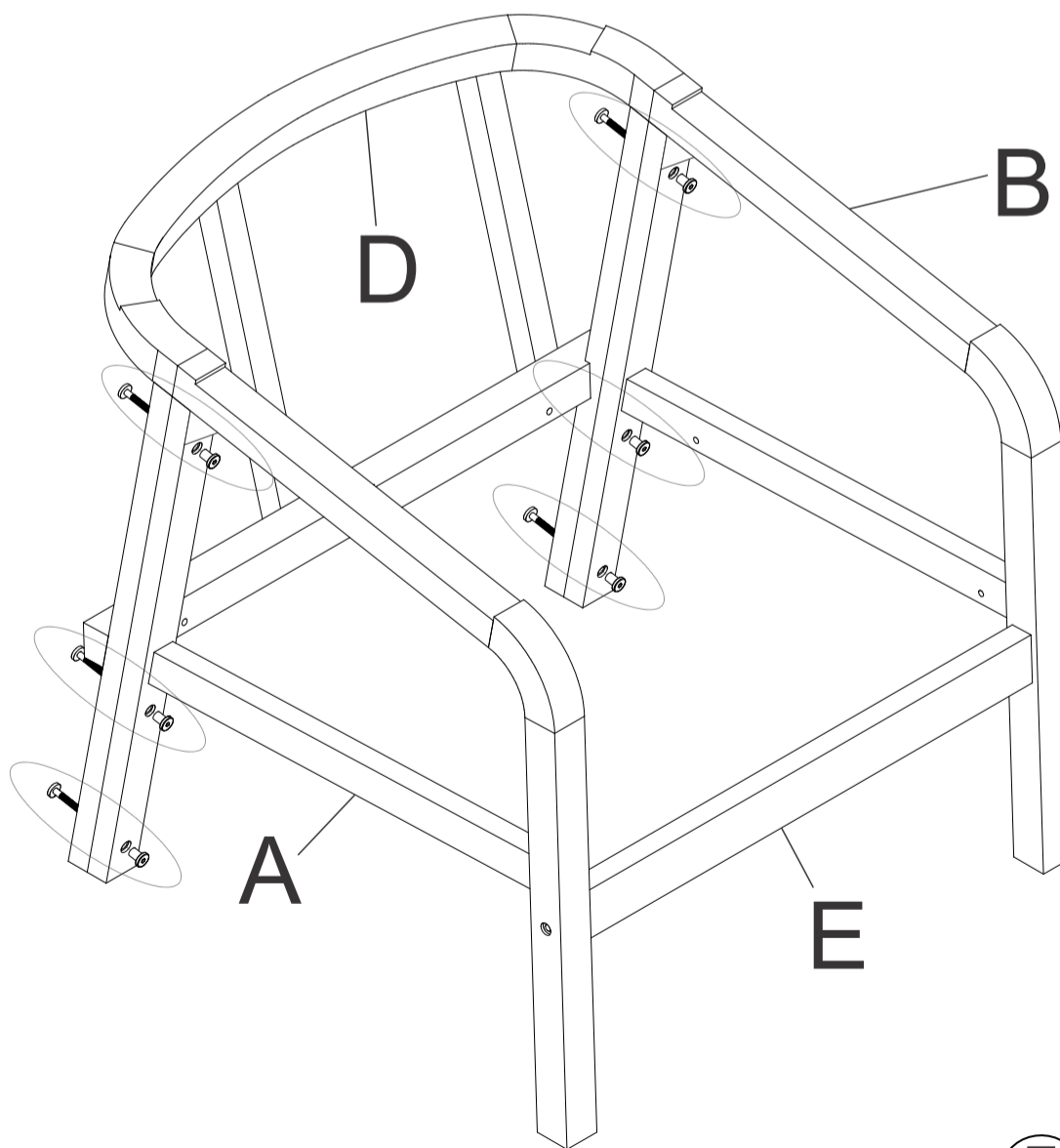

ASSEMBLY INSTRUCTION

3

X2

C

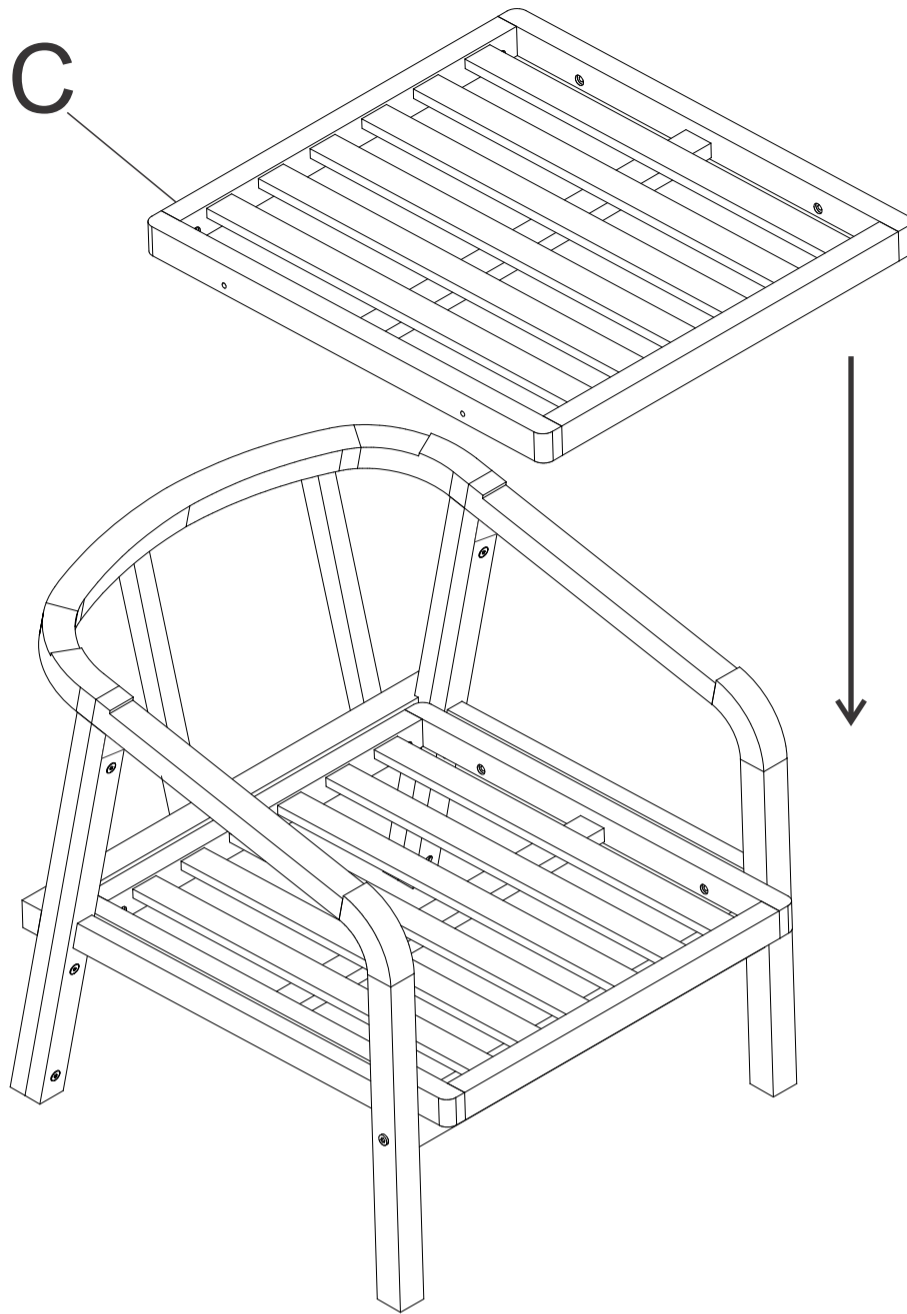

Tighten bolts



4

X2

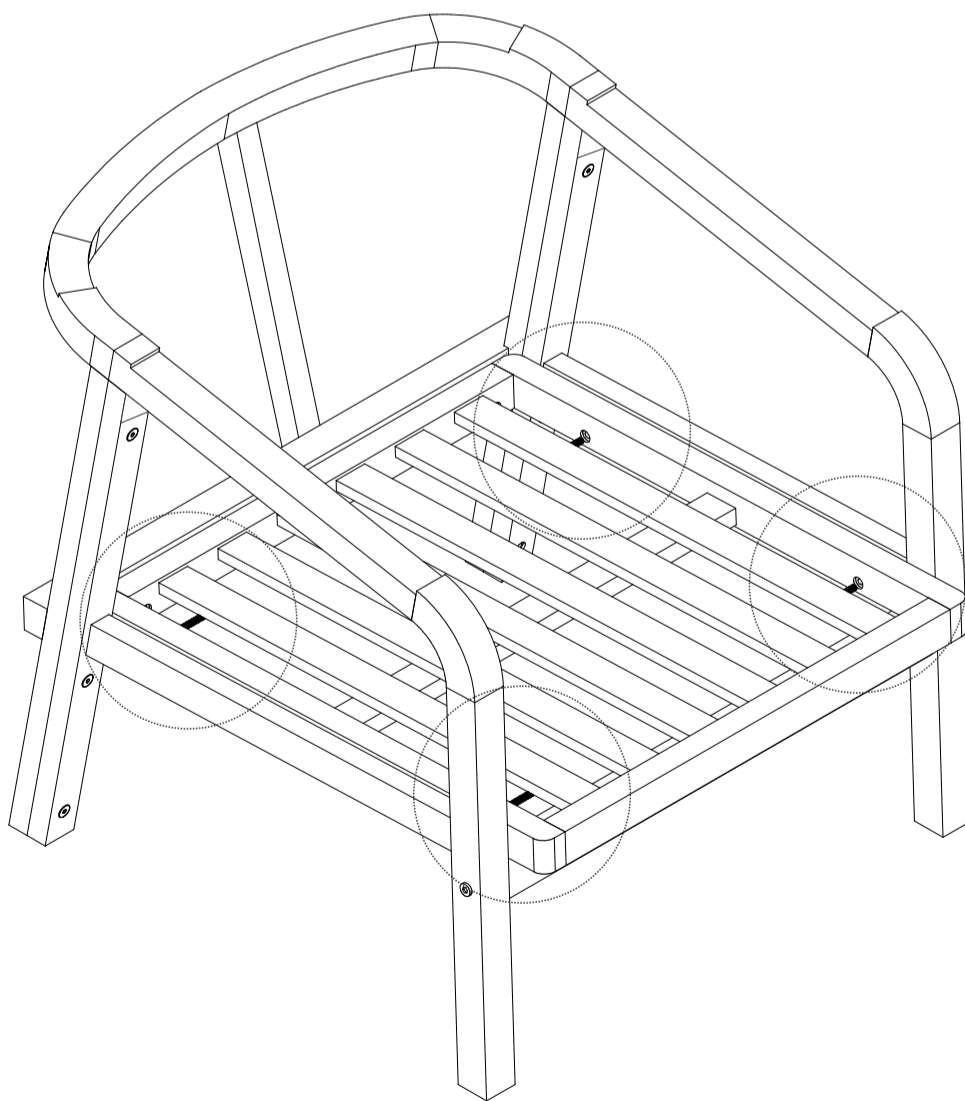

Tighten bolts



4

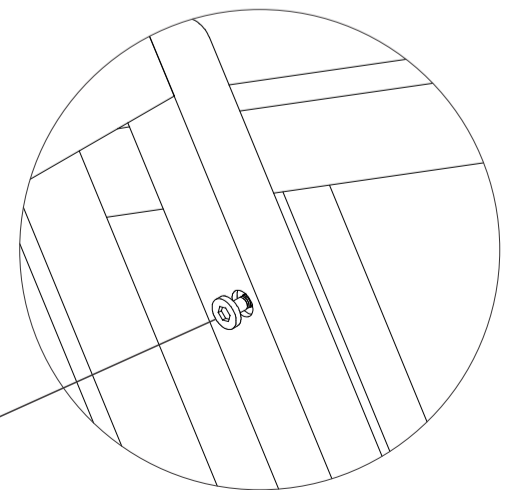

ASSEMBLY INSTRUCTION

5

X2

Tighten
bolts

100%

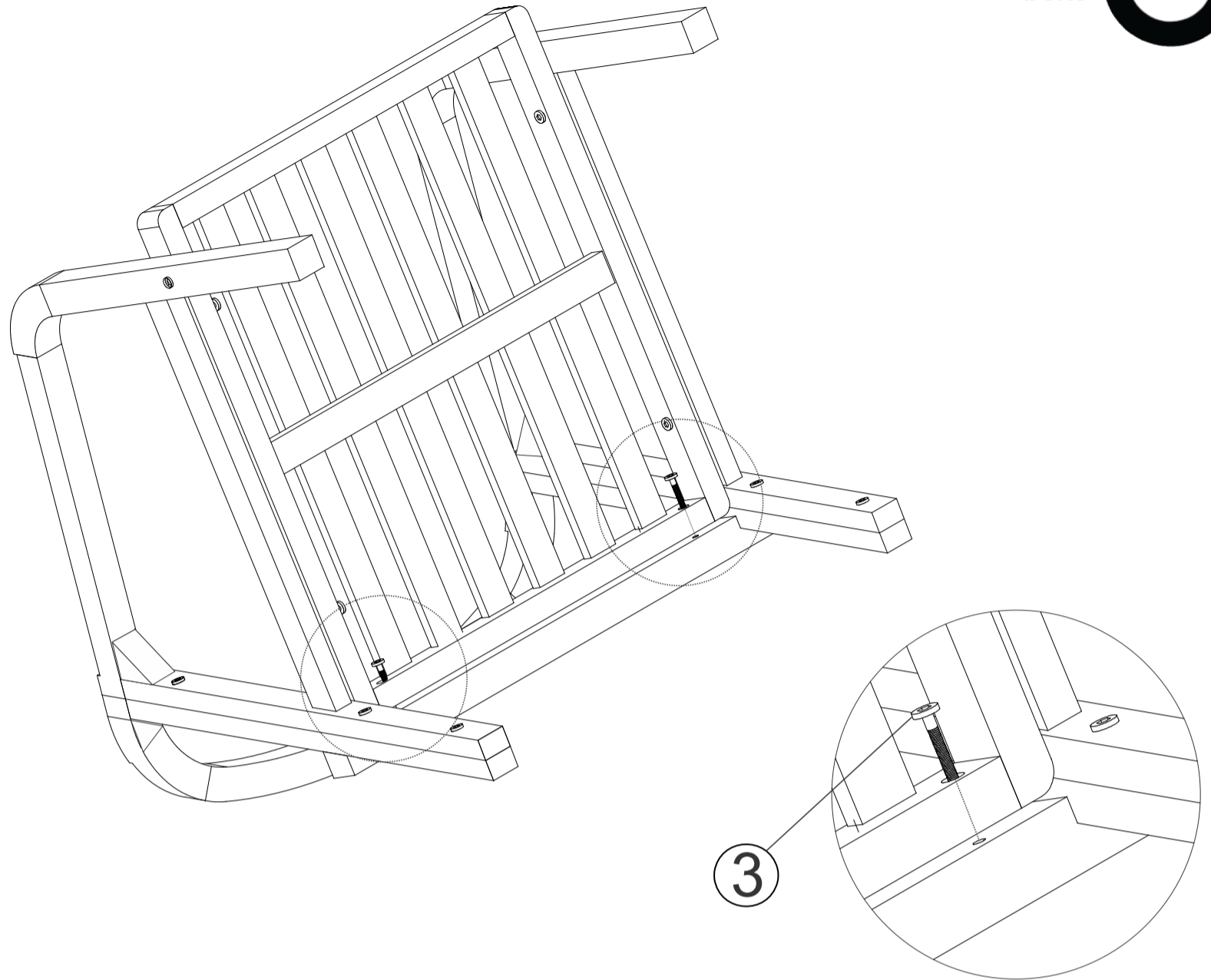

6

X2

Tighten
bolts

100%

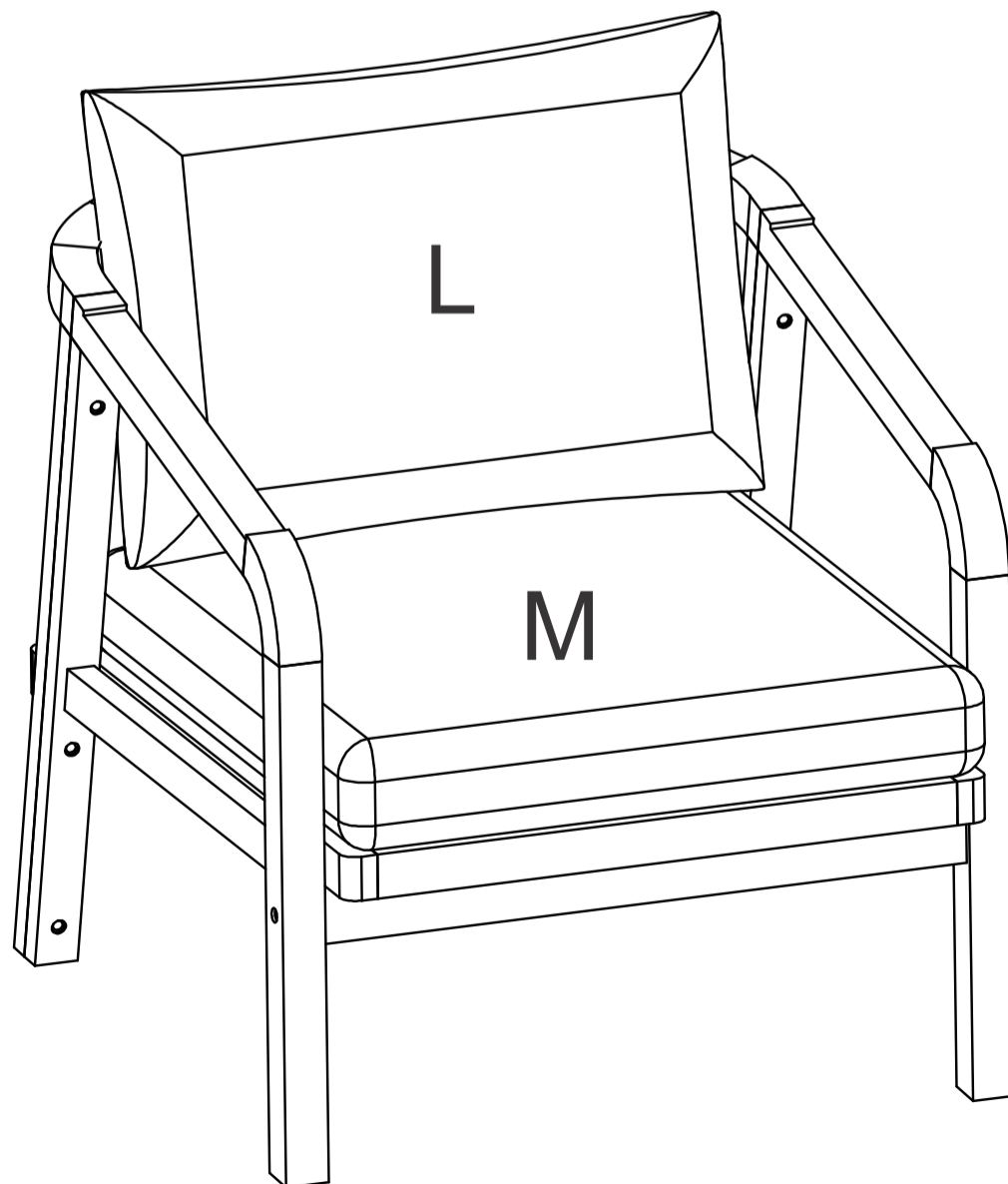

ASSEMBLY INSTRUCTION

7

Tighten bolts 

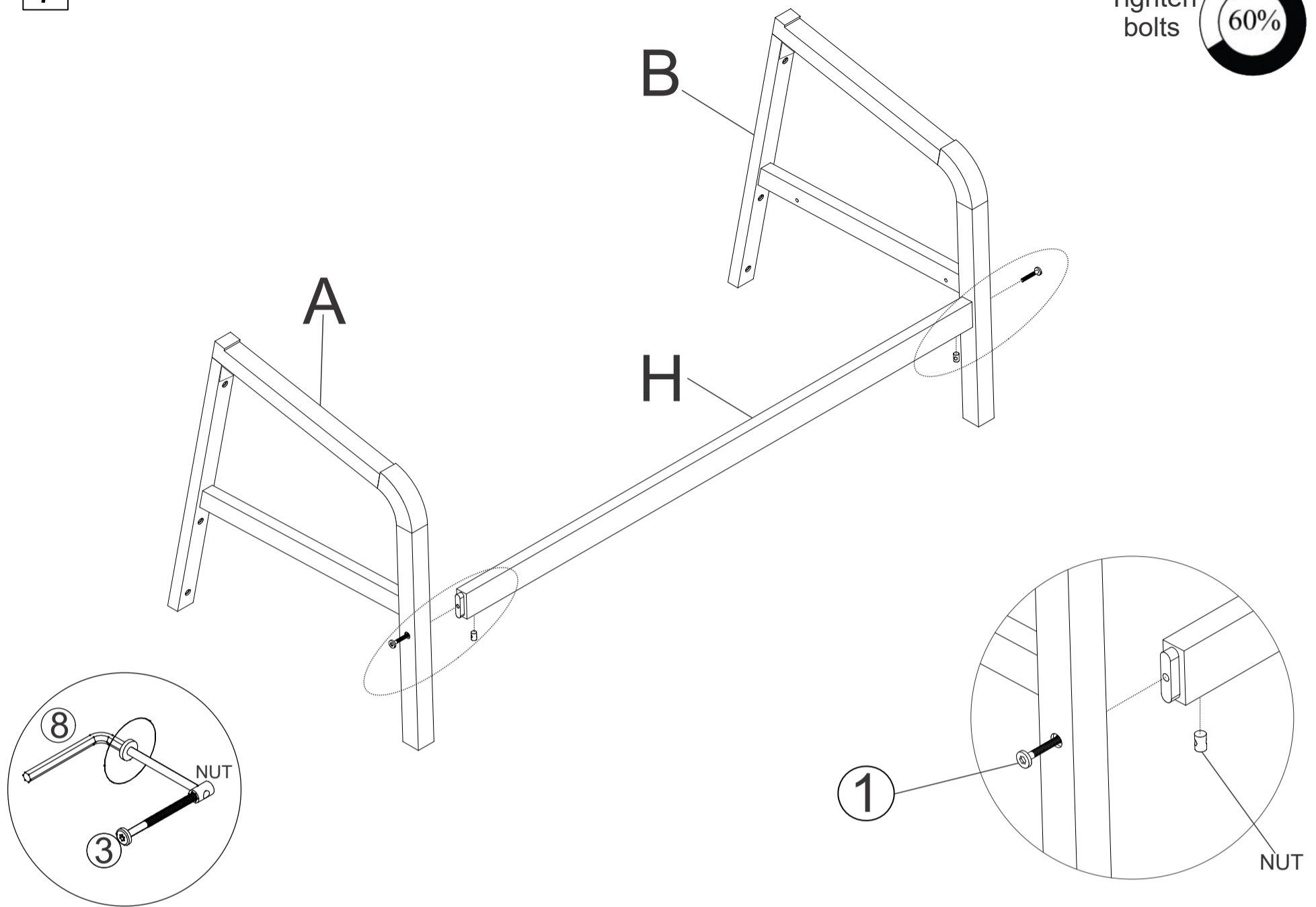

8

Tighten bolts 

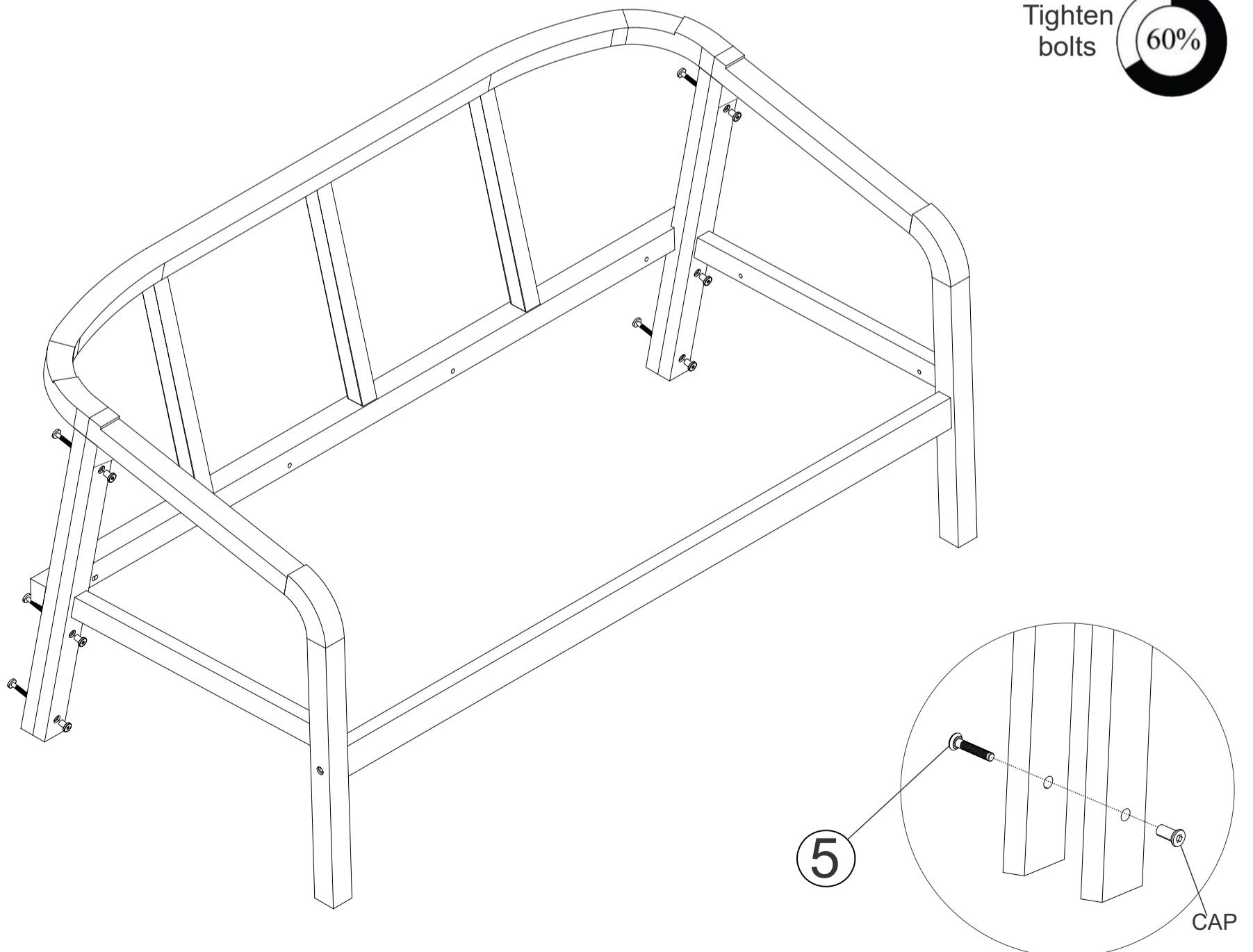

ASSEMBLY INSTRUCTION

9

Tighten bolts 

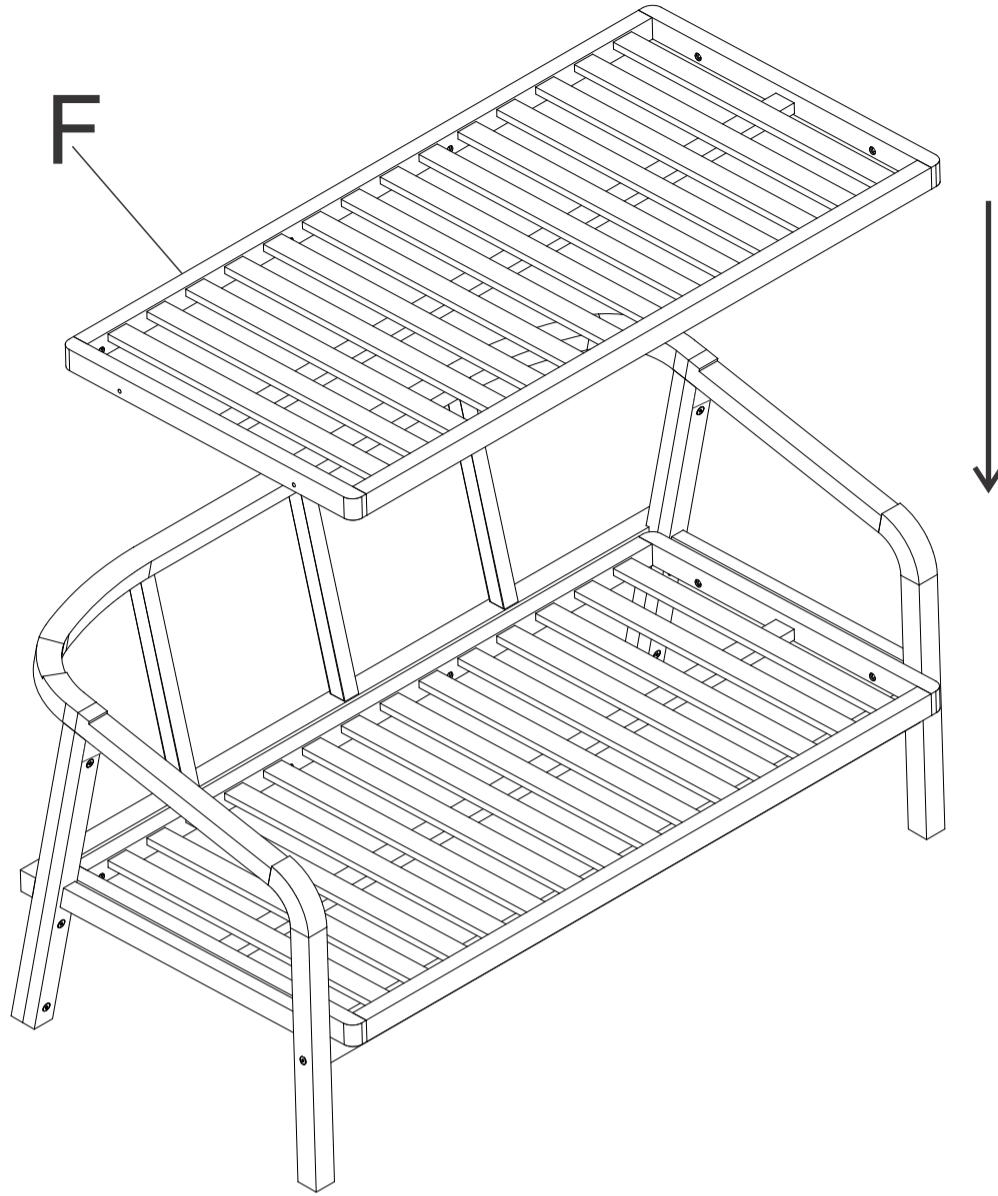

10

Tighten bolts 

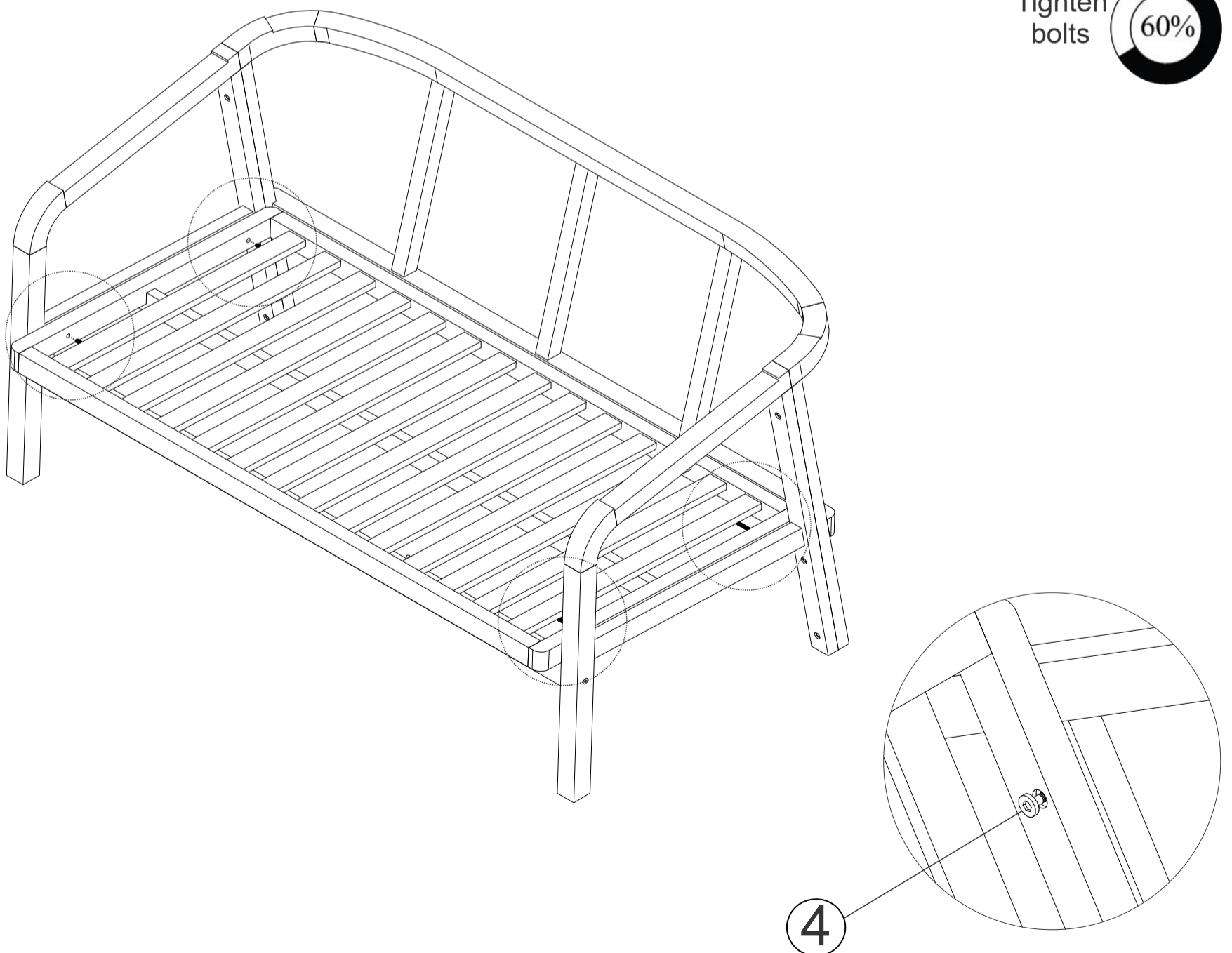

ASSEMBLY INSTRUCTION

11

Tighten
bolts

100%

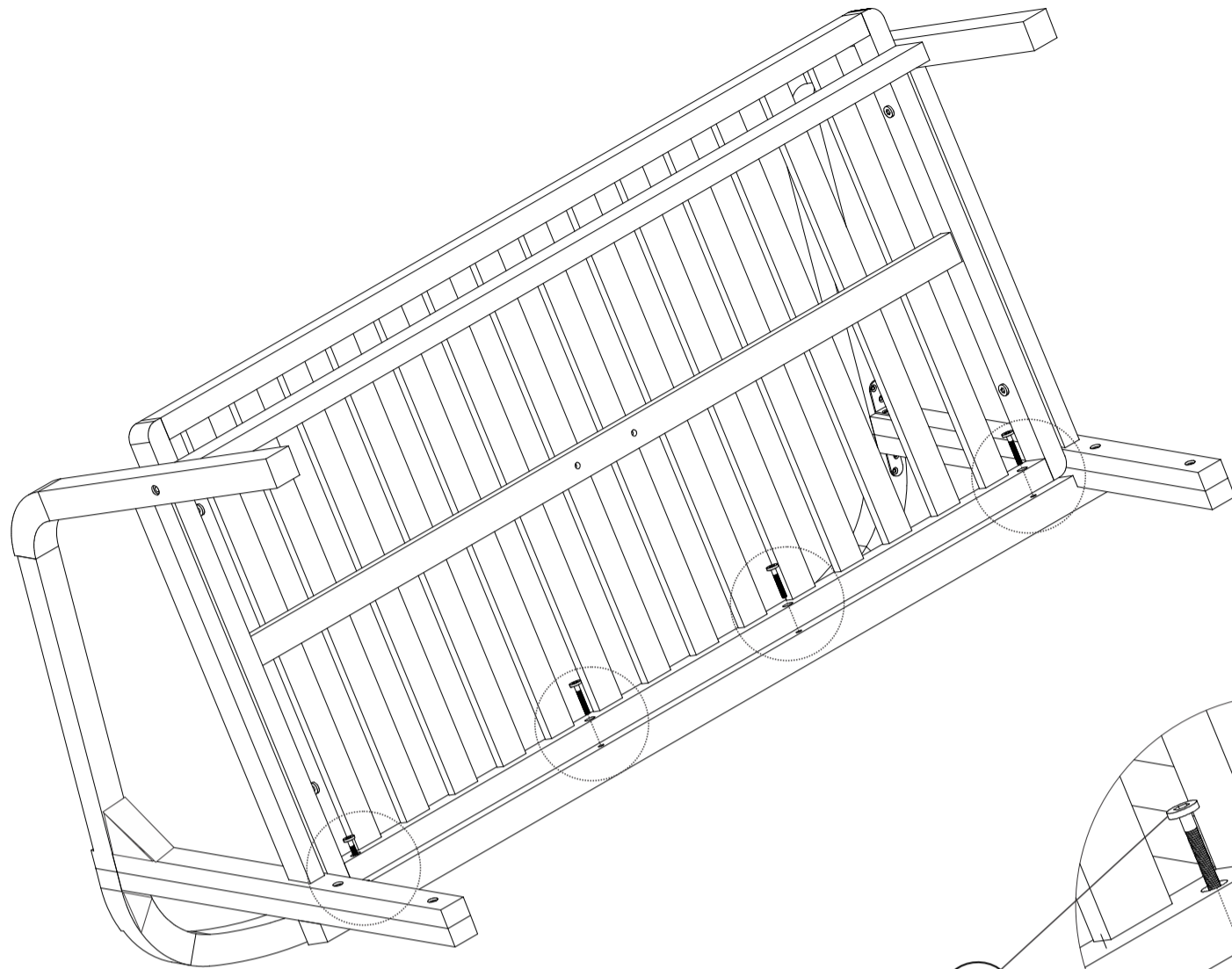

3

12

Tighten
bolts

100%

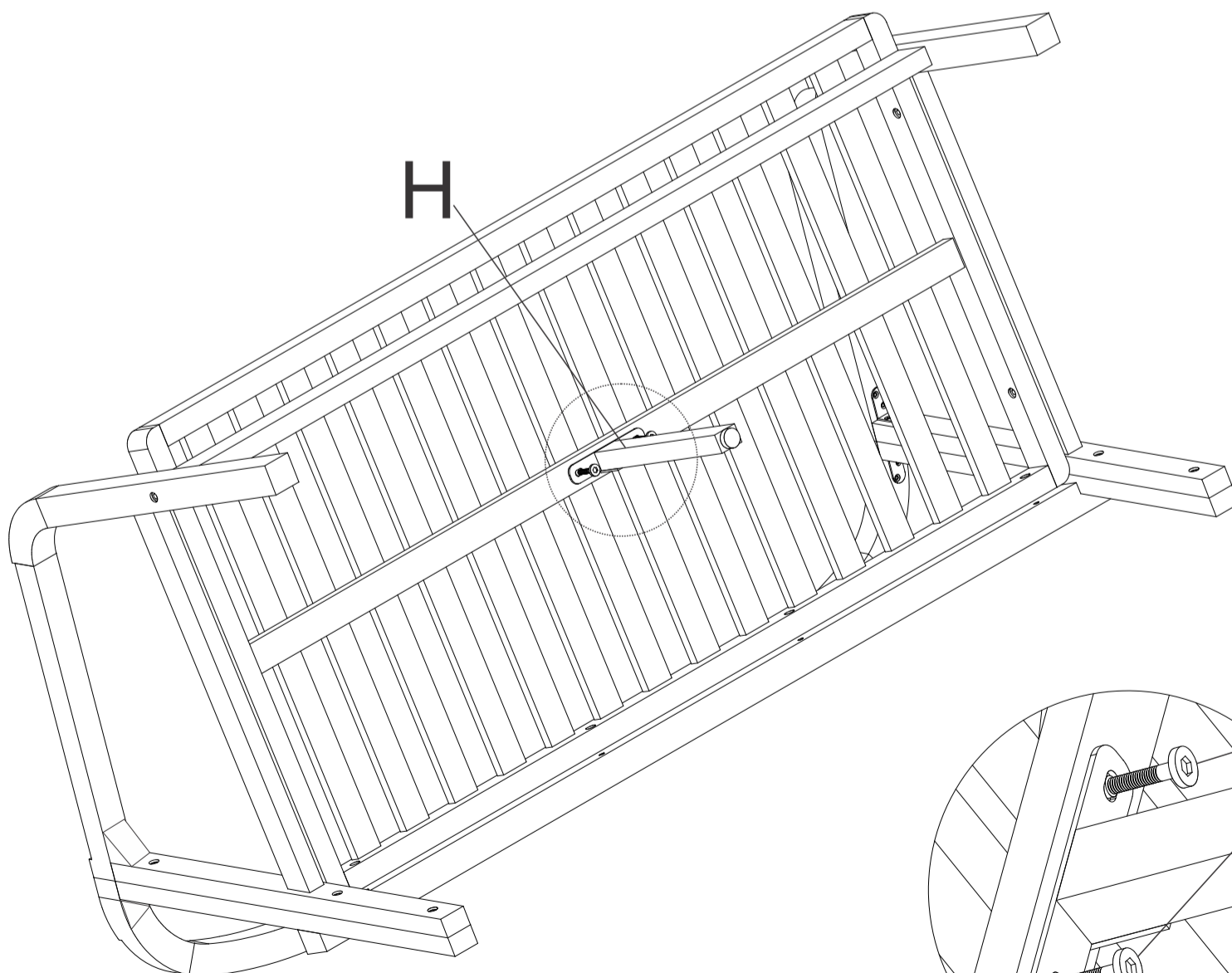

H

6



ASSEMBLY INSTRUCTION

13

Tighten bolts

100%

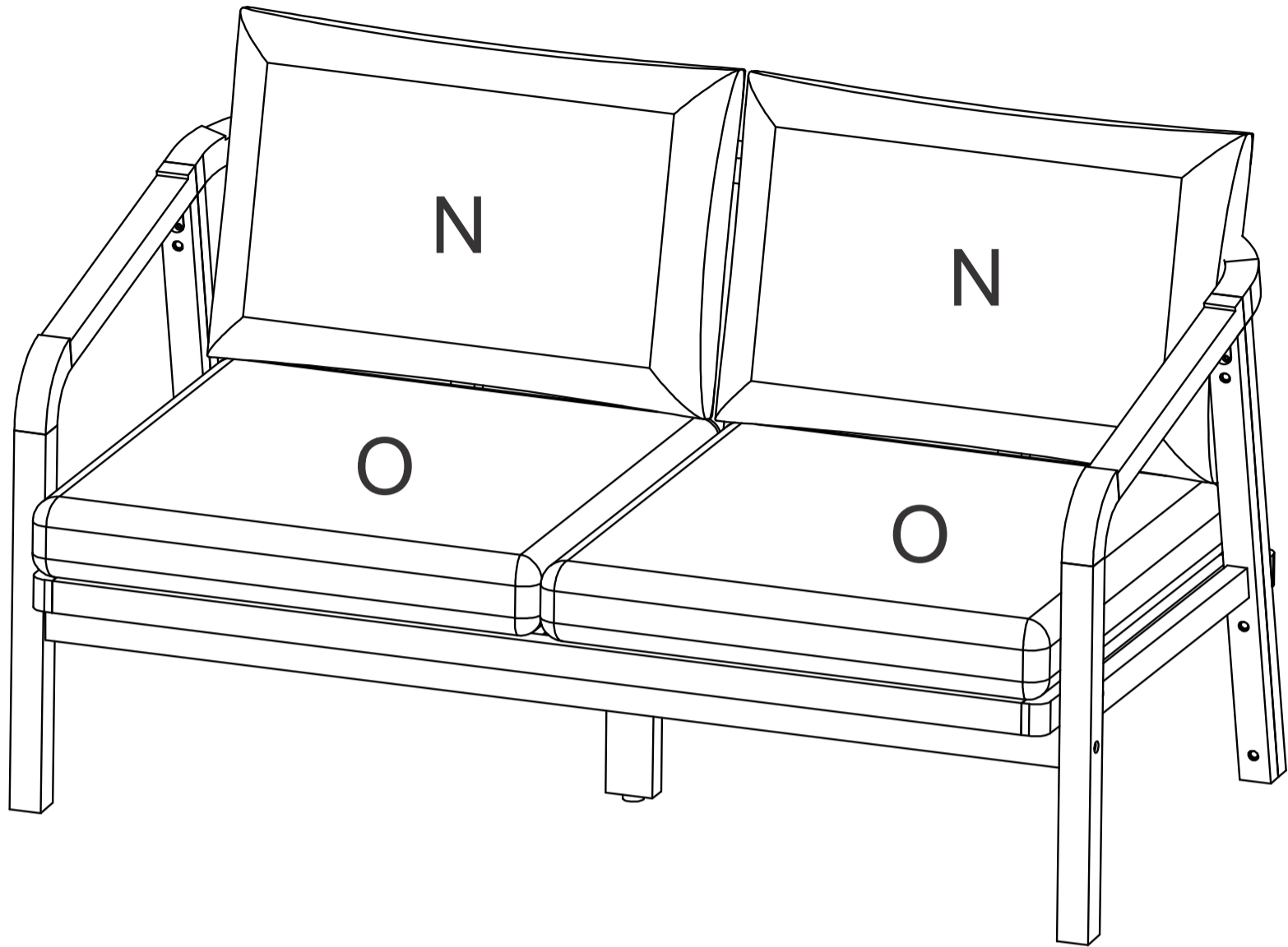

14

Tighten bolts

60%

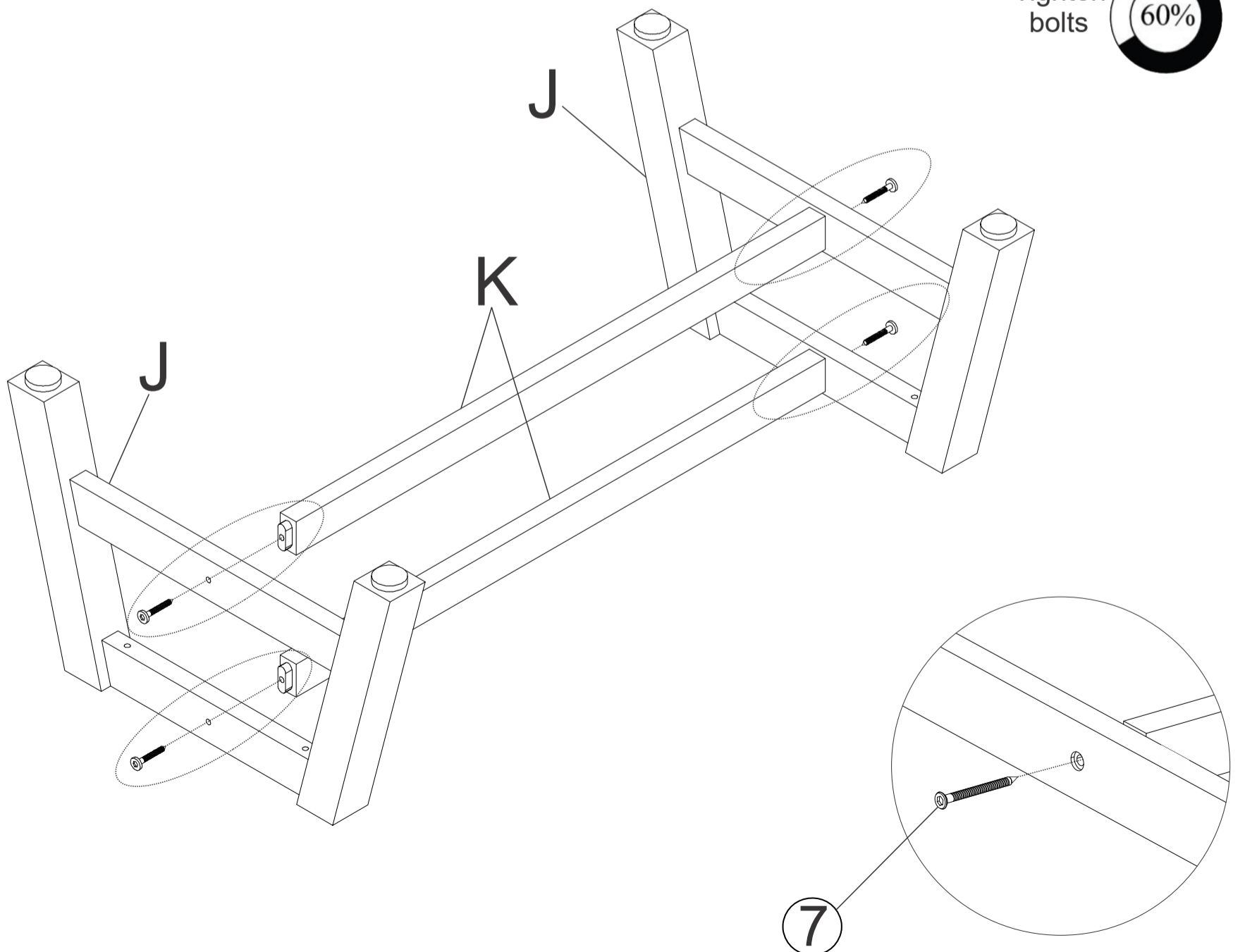

ASSEMBLY INSTRUCTION

15

Tighten bolts

100%

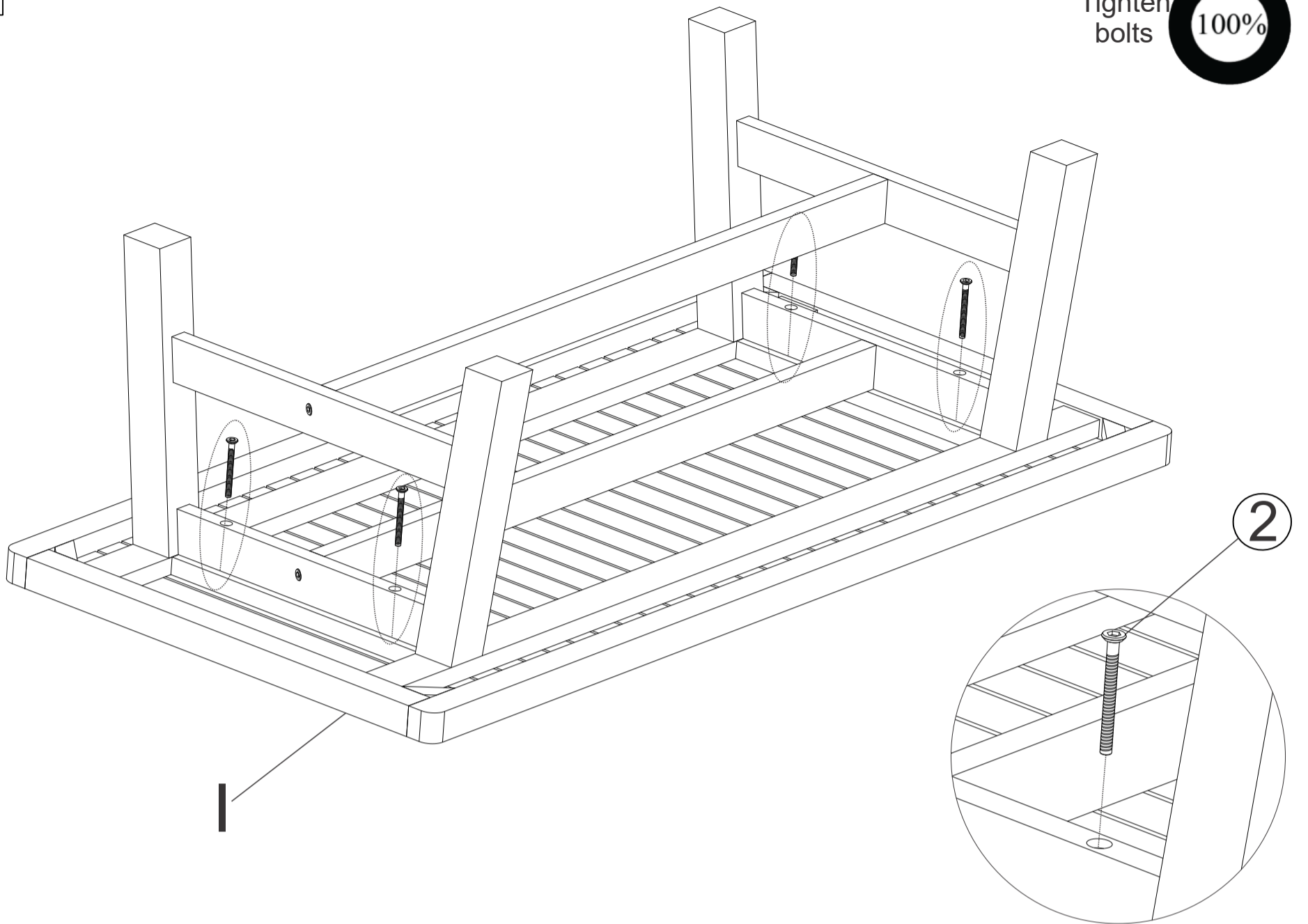

16

Tighten bolts

100%

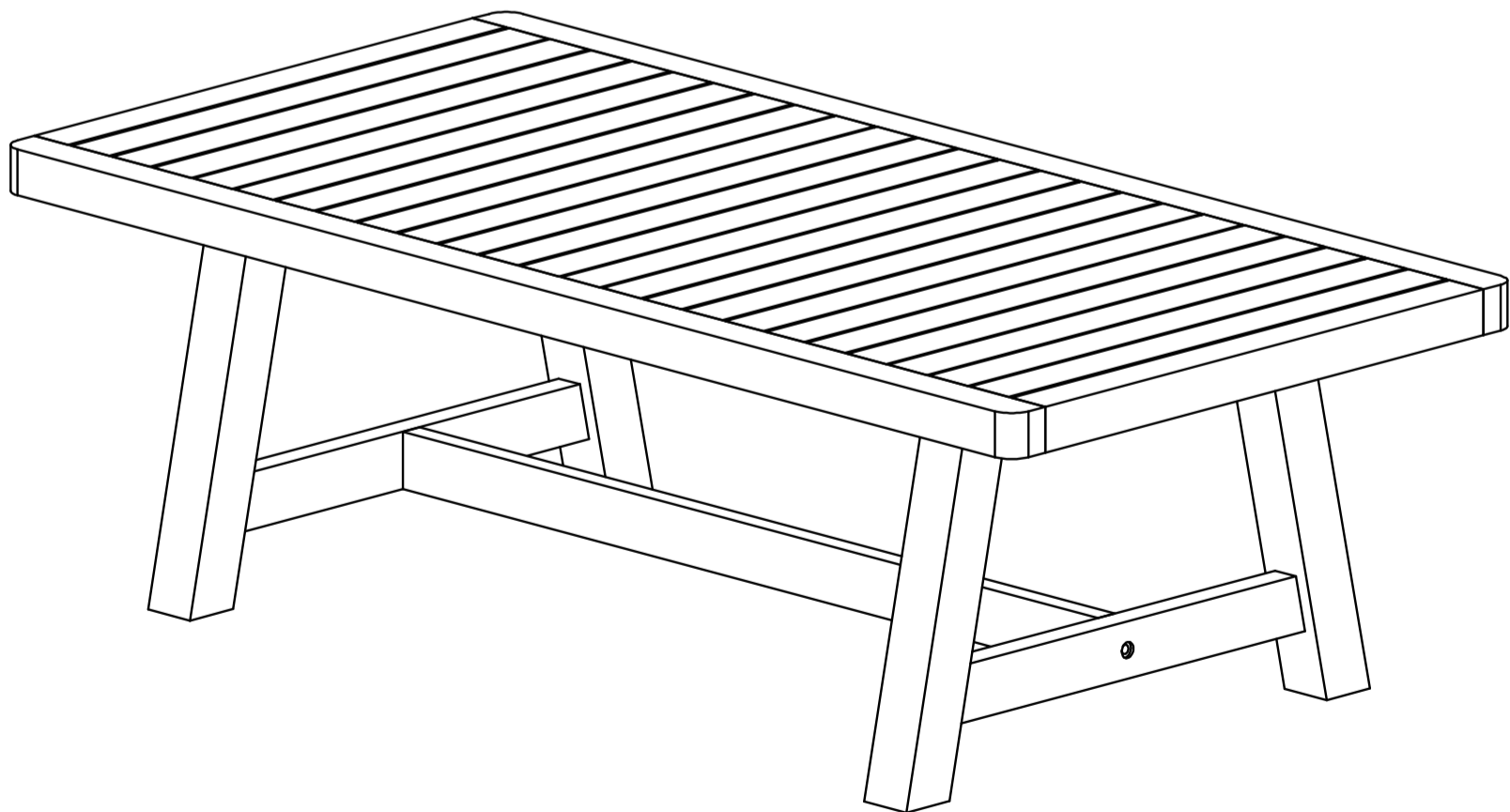

FINISHED.

