

Installation sanleitung Installation Instruction Instruction d'installation



SKU:N879P366357
SKU:N879P366358



FR
Cet appareil,
ses cordons,
et batterie
se recyclent

À DÉPOSER
EN MAGASIN

OU

À DÉPOSER
EN DÉCHÈTERIE

Points de collecte sur www.quefairedemesdechets.fr
Privilégiez la réparation ou le don de votre appareil !

| | |
|------------|--|
| Importeur | Decobus Handel GmbH |
| Adresse | Innungsstraße 9,21244 Buchholz,Deutschland |
| URL | https://www.decobusgroup.de |
| Hersteller | ZHANGZHOU LIFE FURNITURE CO.,LTD |
| Adresse | NO.308 CHAOSHENG ROAD, LONGWEN DISTRICT ZHANGZHOU CITY, FUJIAN PROVINCE (PLANT3) |
| Email/URL | shipping@lifefurniture.cn |
| EC REP | Decobus Handel GmbH Innungsstraße 9,21244 Buchholz,Deutschland https://www.decobusgroup.de |

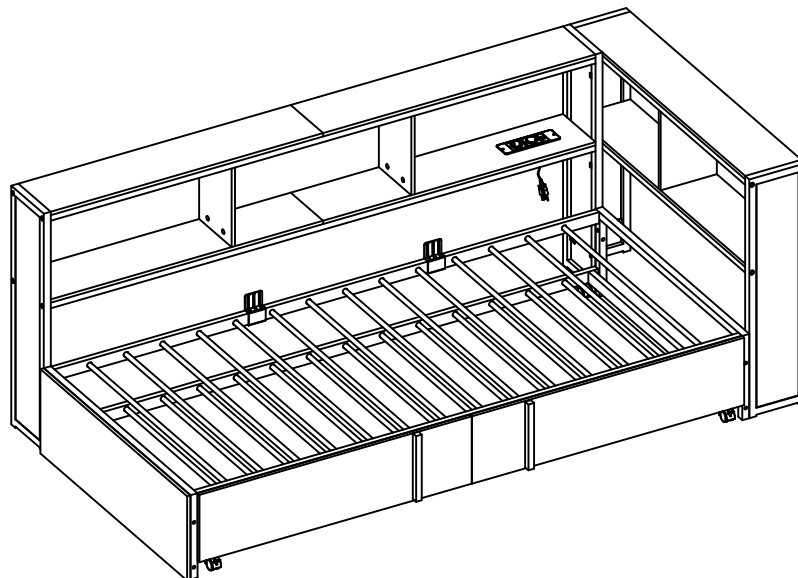
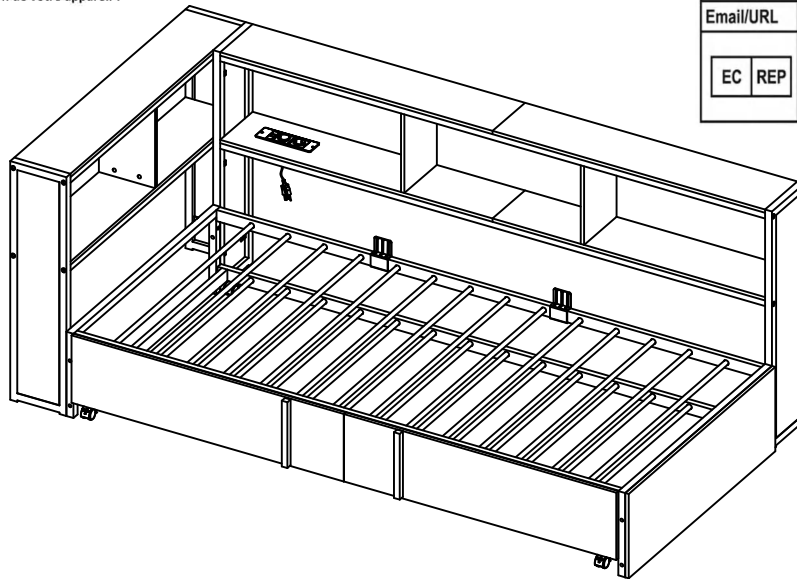

Unser Produkt wird Ihnen in 2 Paketen geliefert. Die Lieferzeiten dieser 2 Pakete können abweichen, bitte haben Sie etwas Geduld und vielen Dank für Ihr Verständnis.

Our product will be delivered to you in 2 packages. The delivery times of these 2 packages may differ, please be patient and thank you for your understanding.

Notre produit vous sera livré en 2 colis. Les délais de livraison de ces 2 colis peuvent différer, soyez patient et merci pour votre compréhension.

English

IMPORTANT ! KEEP FOR FUTURE REFERENCE : READ CAREFULLY

- To be assembled by an adult. Assembly must be checked by an adult before use
- **WARNING !** Keep all screws, small parts and plastic bags out of the reach of children
- Properly identify all parts before assembling
- Never use your item if any of its parts are broken or missing
- Should any problems arise, please contact our After Sales Service
- Manufacturer's instructions shall be followed at all times
- Care: Clean with a soft, dry cloth. In case of larger stains, carefully rub with a slightly damp, non-abrasive sponge
- Avoid the risk of fire by not placing furniture near sources of ignition or hot items
- Do not jump on the bed

Deutsch

WICHTIG ! ZUM SPÄTEREN NACHSCHLAGEN AUFBEWAHREN: SORGFÄLTIG LESEN

- Muss von einem Erwachsenen zusammengebaut werden. Der Zusammenbau muss vor dem Gebrauch von einem Erwachsenen überprüft werden
- **WARNUNG!** Bewahren Sie alle Schrauben, Kleinteile und Plastikbeutel außerhalb der Reichweite von Kindern auf
- Kennzeichnen Sie vor dem Zusammenbau alle Teile richtig
- Benutzen Sie Ihren Artikel niemals, wenn Teile gebrochen sind oder fehlen
- Sollten Probleme auftreten, wenden Sie sich bitte an unseren Kundendienst
- Die Anweisungen des Herstellers sind stets zu befolgen
- Pflege: Mit einem weichen, trockenen Tuch reinigen. Bei größeren Flecken vorsichtig mit einem leicht feuchten, nicht scheuernden Schwamm abreiben. nicht scheuernden Schwamm
- Vermeiden Sie die Gefahr eines Brandes, indem Sie die Möbel nicht in der Nähe von Zündquellen oder heißen Gegenständen aufstellen
- Nicht auf das Bett springen

Français

IMPORTANT ! CONSERVER POUR RÉFÉRENCE ULTÉRIEURE : LIRE ATTENTIVEMENT

- Le montage doit être effectué par un adulte. Le montage doit être vérifié par un adulte avant Utilisation
- **ATTENTION !** Tenir les vis, les petites pièces et les sachets en plastique hors de portée des enfants
- Identifiez correctement toutes les pièces avant de les assembler
- N'utilisez jamais votre article si l'une de ses pièces est cassée ou manquante
- En cas de problème, veuillez contacter notre service après-vente
- Les instructions du fabricant doivent être respectées à tout moment
- Entretien : nettoyer avec un chiffon doux et sec. En cas de taches plus importantes, frotter soigneusement avec une éponge non abrasive légèrement humide. légèrement humide et non Abrasive
- Évitez les risques d'incendie en ne plaçant pas les meubles à proximité de sources d'inflammation ou d'objets chauds
- Ne pas sauter sur le lit

Italiano

IMPORTANTE! CONSERVARE PER RIFERIMENTO FUTURO: LEGGERE ATTENTAMENTE

- Deve essere assemblato da un adulto. L'assemblaggio deve essere controllato da un adulto prima dell'uso
- **ATTENZIONE!** Tenere tutte le viti, le piccole parti e i sacchetti di plastica fuori dalla portata dei bambini
- Identificare correttamente tutte le parti prima dell'assemblaggio
- Non utilizzare mai l'articolo se alcune parti sono rotte o mancanti
- In caso di problemi, si prega di contattare il nostro Servizio Post Vendita
- Le istruzioni del produttore devono essere sempre seguite
- Cura: Pulire con un panno morbido e asciutto. In caso di macchie più estese, strofinare accuratamente con una spugna leggermente umida e non abrasiva
- Evitare il rischio di incendio, non collocando i mobili vicino a fonti di accensione o a oggetti caldi
- Non saltare sul letto

Español

¡ IMPORTANTE ! CONSERVELO PARA FUTURAS CONSULTAS: LEA ATENTAMENTE

- Debe ser montado por un adulto. El montaje debe ser comprobado por un adulto antes del uso
- ADVERTENCIA** Mantenga todos los tornillos, piezas pequeñas y bolsas de plástico fuera del alcance de los niños.
- Identifique correctamente todas las piezas antes de montarlas
 - Nunca utilice su artículo si alguna de sus piezas está rota o falta
 - Si surge algún problema, póngase en contacto con nuestro Servicio Postventa
 - Las instrucciones del fabricante deben seguirse en todo momento
 - Cuidado: Limpiar con un paño suave y seco. En caso de manchas más grandes, frote cuidadosamente con una esponja no abrasiva ligeramente humedecida.
 - Evite el riesgo de incendio no colocando los muebles cerca de fuentes de ignición u objetos calientes.
 - No saltar sobre la cama.

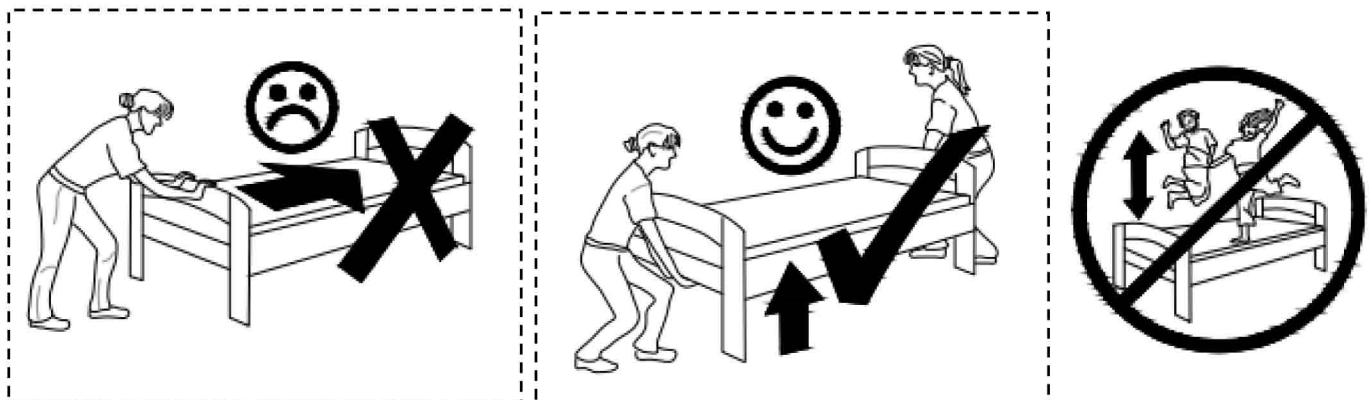

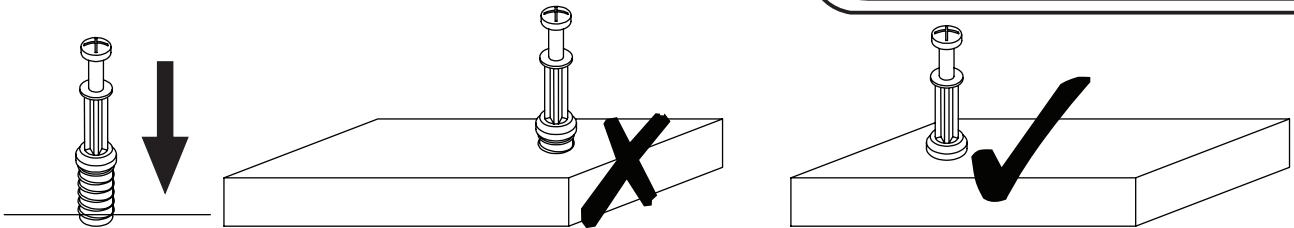

EN_QUICKFIT: Tighten quickfit until shoulder is flush with panel. Do not overtighten or undertighten.

FR_RACCORD RAPIDE: Faites serrer le raccord rapide jusqu'à ce que l'épaulement soit parfaitement encastré dans le panneau. Il ne faut ni trop serrer ni insuffisamment serrer.

ES_QUICKFIT: Apriete quickfit hasta que el hombro se descargue con el panel. NO lo sobreapriete ni lo apriete poco.

DE_QUICKFIT: Ziehen Sie den Quickfit fest, bis die Schulter mit der Platte bündig ist. Bitte nicht zu fest oder zu schwach anziehen.

IT_MONTAGGIO RAPIDO: Stringere il montaggio rapido fino a quando la spalla è a filo con il pannello, non stringere troppo o troppo poco.

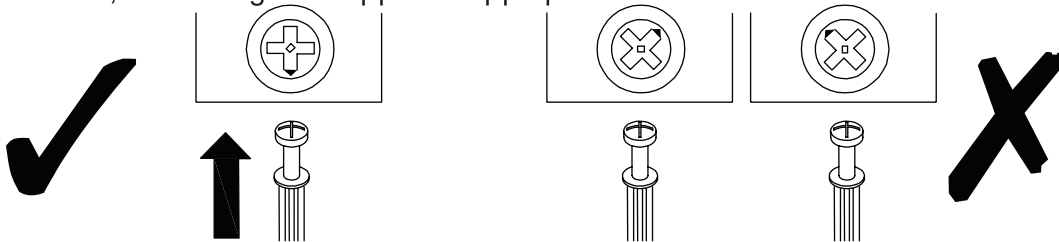

EN_CAM LOCK: When fitting cam lock, ensure starting position is correct before you insert connecting quickfit.

FR_SERRURE BATTEUSE: Avant d'insérer la serrure batteuse, veillez à la bonne orientation avant d'insérer le raccord rapide.

ES_CIERRE DE LA CÁMARA: Cuando instale el cierre de la cámara, asegúrese de que la posición de inicio es correcta antes de que inserte el quickfit conector.

DE_CAM-LOCK: Achten Sie bei der Montage des Cam-Locks auf die richtige Ausgangsposition, bevor Sie den Quickfit einsetzen.

IT_BLOCCAGGIO A CAMMA: Quando si monta il bloccaggio a camma, assicurarsi che la posizione iniziale sia corretta prima di inserire il montaggio rapido di collegamento.

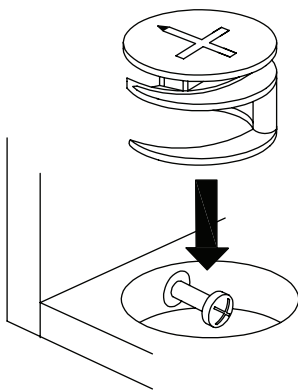

EN_Quickfit head should be in the centre of the cam lock when the two panels are joined.

Cam lock should be inserted before quickfit.

FR_Lorsque les deux panneaux sont assemblés, la tête du raccord rapide doit reposer au centre de la serrure batteuse. Il faut insérer la serrure batteuse avant le raccord rapide.

ES_El cabezal del quickfit debe estar en el centro del cierre de la cámara cuando se unan los dos paneles.

Se debe insertar el cierre de la cámara antes que el quickfit.

DE_Der Quickfit-Kopf sollte sich in der Mitte des Cam-Locks befinden, wenn die beiden Platten zusammengefügt sind. Der Cam-Lock sollte vor dem Quickfit eingesetzt werden.

IT_La testa del montaggio rapido deve trovarsi al centro del bloccaggio a camma quando i due pannelli sono uniti.

Il Bloccaggio a Camma deve essere inserito prima del montaggio rapido.

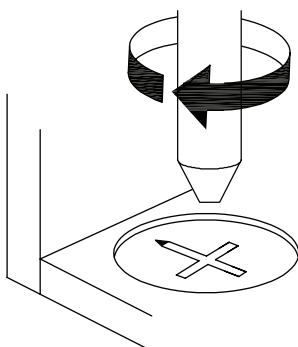

EN_Turn cam lock clockwise to tighten.

FR_Faites tourner la serrure batteuse dans le sens des aiguilles d'une montre pour la resserrer.







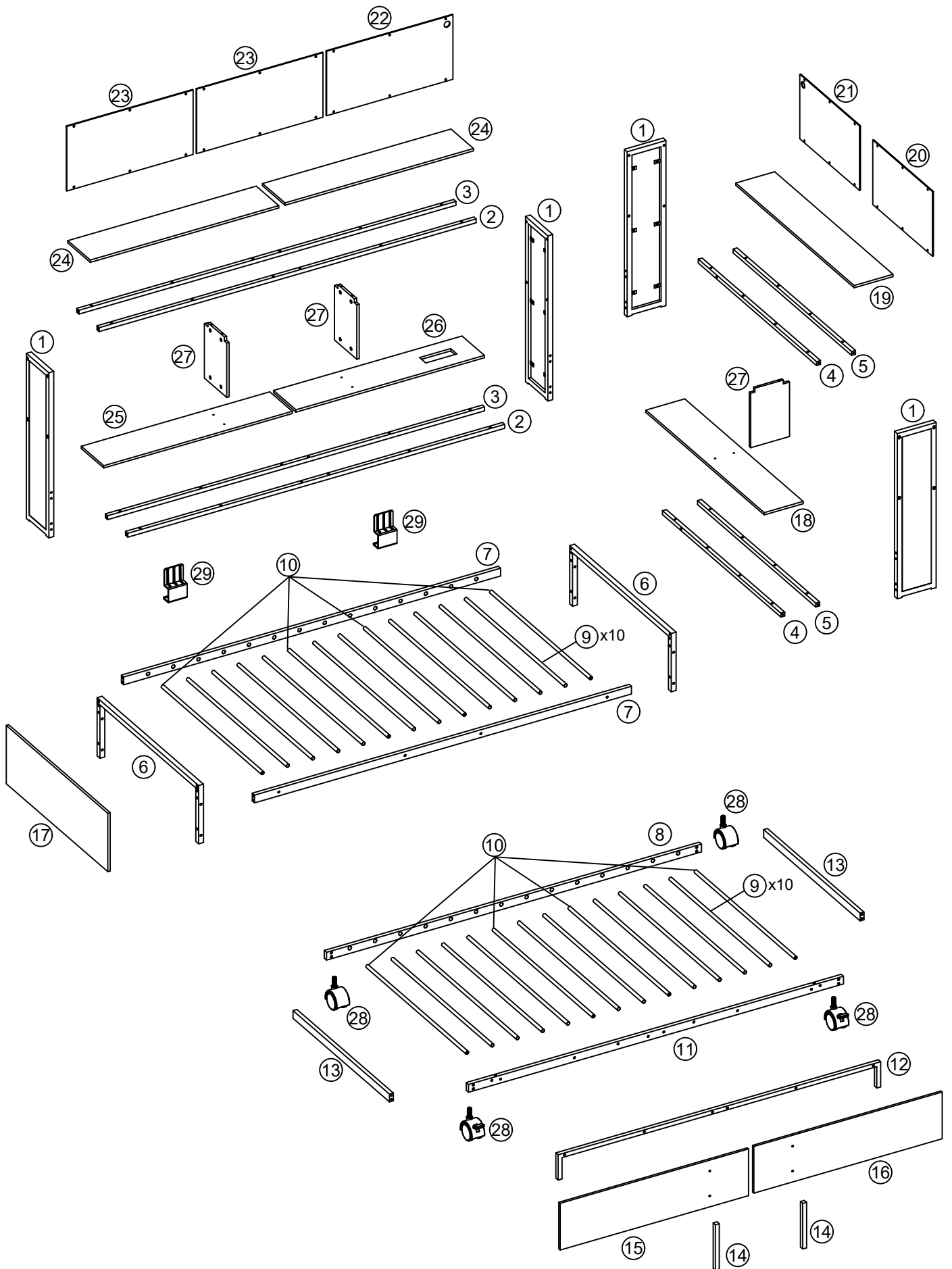

ES_Gire el cierre de la cámara en sentido horario para apretarlo.

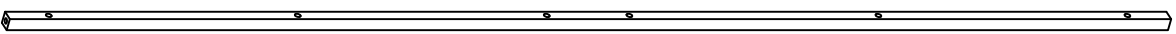
DE_Drehen Sie den Cam-Lock im Uhrzeigersinn, um ihn festzuziehen.

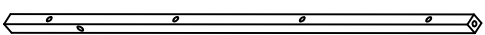
IT_Ruotare il bloccaggio a camma in senso orario per stringere.

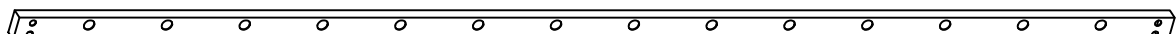
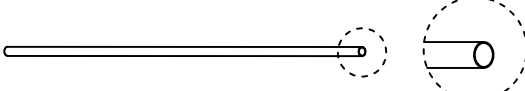
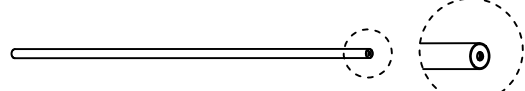
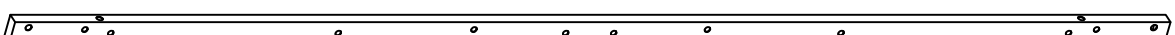
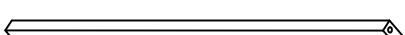
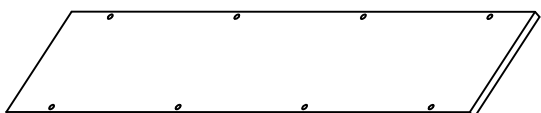
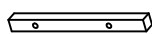
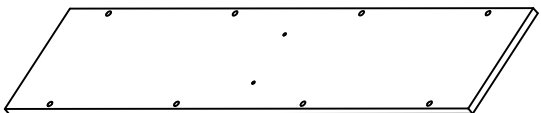
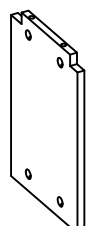

Parts List For N879P366358

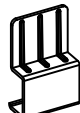
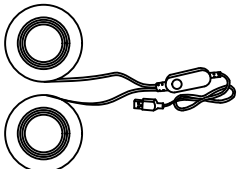
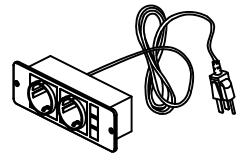
| | |
|--|--------------|
| <p>②</p>  | <p>2pcs</p> |
| <p>③</p>  | <p>2pcs</p> |
| <p>④</p>  | <p>2pcs</p> |
| <p>⑦</p>  | <p>2pcs</p> |
| <p>⑧</p>  | <p>1pc</p> |
| <p>⑨</p>  | <p>20pcs</p> |
| <p>⑩</p>  | <p>8pcs</p> |
| <p>⑪</p>  | <p>1pc</p> |
| <p>⑬</p>  | <p>2pcs</p> |
| <p>⑮</p>  | <p>1pc</p> |
| <p>⑭</p>  | <p>2pcs</p> |
| <p>⑱</p>  | <p>1pc</p> |
| <p>⑳</p>  | <p>2pcs</p> |
| <p>㉓</p>  | <p>x1</p> |
| <p>㉔</p>  | <p>x2</p> |
| <p>㉕</p>  | <p>x2</p> |
| <p>㉖</p>  | <p>2pcs</p> |
| <p>㉗</p>  | <p>1pc</p> |
| <p>㉘</p>  | <p>1pc</p> |

Parts List For N879P366357

①

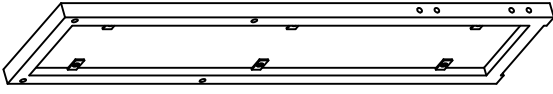

4pcs

⑥



2pcs

⑮

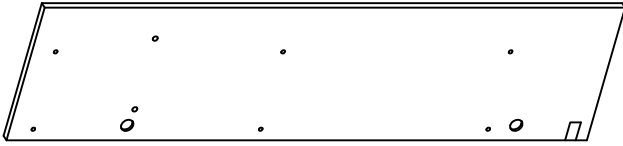

1pc

⑯

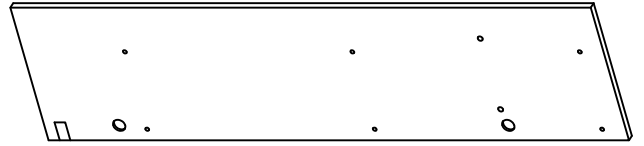

1pc

⑰

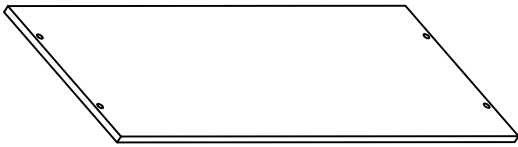

1pc

⑳

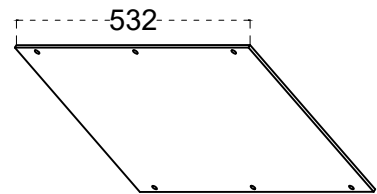

1pc

㉑

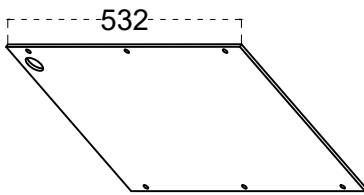

1pc

㉒

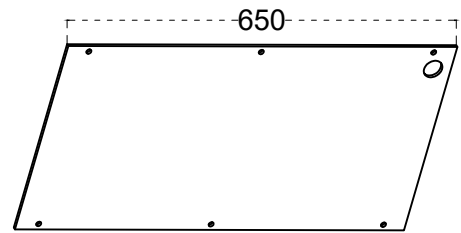

1pc

㉓

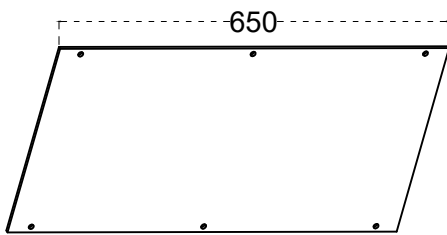

2pcs

㉔

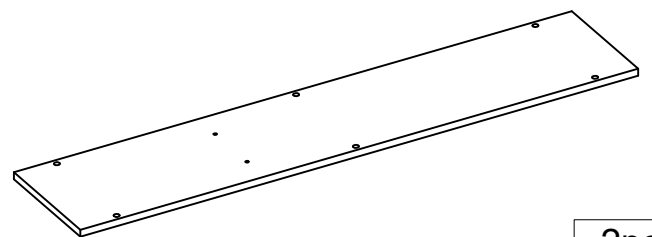

2pcs

㉕

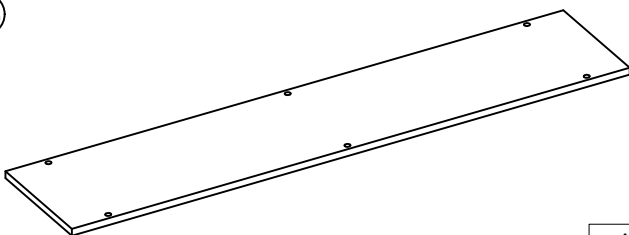

1pc

㉖

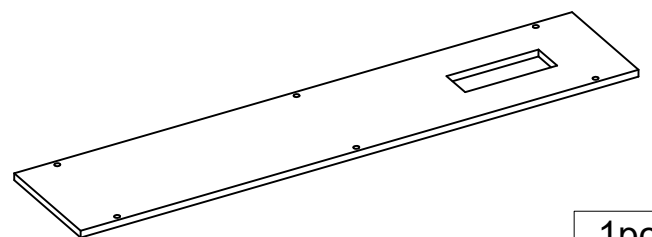





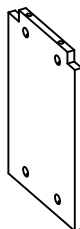

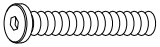
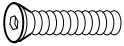
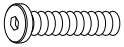
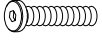

1pc

㉗



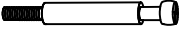

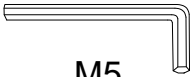
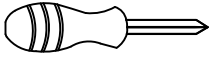
1pc

Hardware For N879P366358

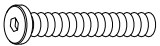
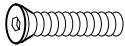
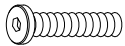
| | | | |
|--|--|---|---|
| <p>(A)</p>  <p>M8×60mm</p> <p>4pcs</p> | <p>(B)</p>  <p>M8×45mm</p> <p>22pcs</p> | <p>(C)</p>  <p>M8×40mm</p> <p>14pcs</p> | <p>(D)</p>  <p>M6×35mm</p> <p>4pcs</p> |
| <p>(E)</p>  <p>M6×28mm</p> <p>56pcs</p> | <p>(F)</p>  <p>M6×15mm</p> <p>46pcs</p> | <p>(G)</p>  <p>M3×12mm</p> <p>2pcs</p> | <p>(H)</p>  <p>6×35mm</p> <p>12pcs</p> |
| <p>(I)</p>  <p>Ø15×9.5mm</p> <p>12pcs</p> | <p>(J)</p>  <p>M4</p> <p>1pc</p> | <p>(K)</p>  <p>M5</p> <p>1pc</p> | <p>(L)</p>  <p>1pc</p> |
| <p>(M)</p>  <p>12pcs</p> | | | |

| | | | |
|---|--|---|--|
| <p>(A)</p>  <p>M8×60mm</p> <p>4pcs</p> | <p>(B)</p>  <p>M8×45mm</p> <p>22pcs</p> | <p>(C)</p>  <p>M8×40mm</p> <p>14pcs</p> | |
|---|--|---|--|

Bitte beachten Sie, dass die Formen der Schrauben A und B und C ähnlich sind. Bitte installieren Sie entsprechend der Anleitung und unterscheiden Sie sie!
Please note that the shapes of screws A and B and C are similar. Please install according to the instructions and distinguish them!
Notez que les vis A et B et C ont des formes similaires. Veuillez les installer en suivant les instructions pour les séparer!

| | | | |
|---|--|--|--|
| <p>(D)</p>  <p>M6×35mm</p> <p>4pcs</p> | <p>(E)</p>  <p>M6×28mm</p> <p>56pcs</p> | <p>(F)</p>  <p>M6×15mm</p> <p>46pcs</p> | |
|---|--|--|--|

Bitte beachten Sie, dass die Formen der Schrauben D und E und F ähnlich sind. Bitte installieren Sie entsprechend der Anleitung und unterscheiden Sie sie!
Please note that the shapes of screws D and E and F are similar. Please install according to the instructions and distinguish them!
Notez que les vis D et E et F ont des formes similaires. Veuillez les installer en suivant les instructions pour les séparer!

Vor dem Einbau die Schrauben in die Löcher stecken und festziehen, aber nicht bis 100%, 70% bis 80% anziehen reicht aus. Schließlich, nachdem alle Schrauben installiert sind, ziehen Sie alle Schrauben auf 100%. Wenn Sie auf diese Probleme stoßen, wie z. B. Fehlausrichtung der Löcher oder Unfähigkeit, bestimmte Teile zu installieren, überprüfen Sie bitte, ob die Schrauben korrekt verwendet werden und passen Sie die Dichtigkeit der Schrauben an.

Before installation, insert the screws into the holes and tighten them, but do not tighten them to 100%, 70% to 80% is sufficient. Finally, after all screws are installed, tighten all screws to 100%. If you encounter these issues, such as if the holes cannot be aligned or some parts cannot be installed, please check if the screws are used correctly and adjust the tightness of the screws.

Insérer la vis dans le trou avant la fin de l'assemblage, serrer la vis, mais ne pas serrer à 100%, 70% ~ 80% est correct. Enfin, une fois que toutes les vis sont bien serrées, toutes les vis sont serrées à 100%. Si vous rencontrez ces problèmes, par exemple si les trous ne sont pas alignés ou si certaines pièces ne peuvent pas être montées, vérifiez que les vis sont utilisées correctement et Ajustez leur serrage.

2

A

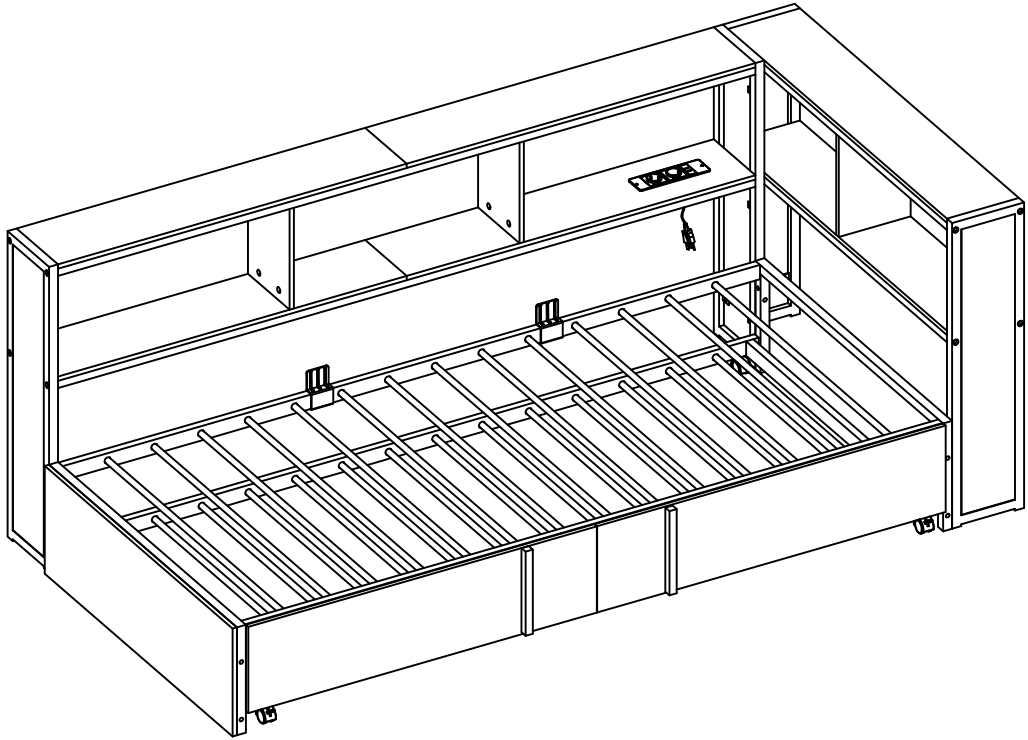

3

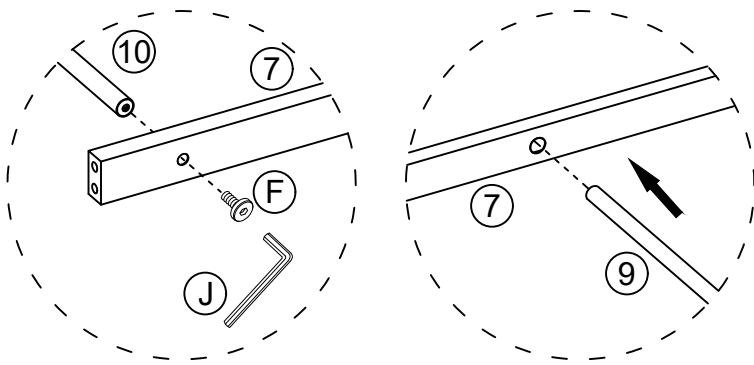

M6*15mm

(F) × 8PCS

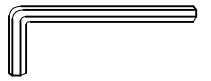

M4

(J) × 1PC

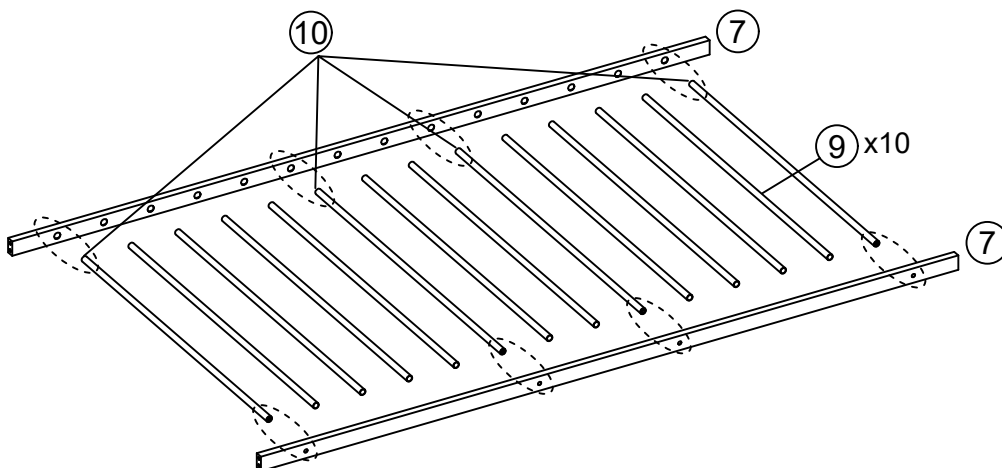

M6*15mm

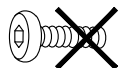

M6*28mm

4

There is a countersink in this direction

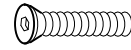
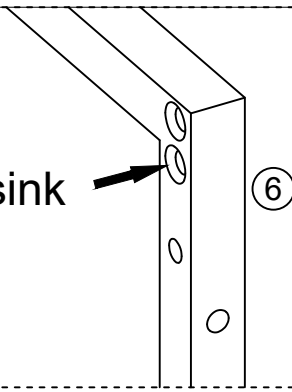

M8*45mm

(B) × 8PCS



M5

(K) × 1PC

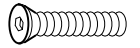
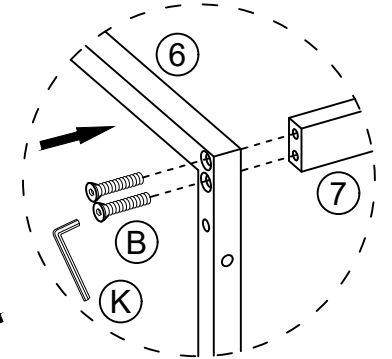
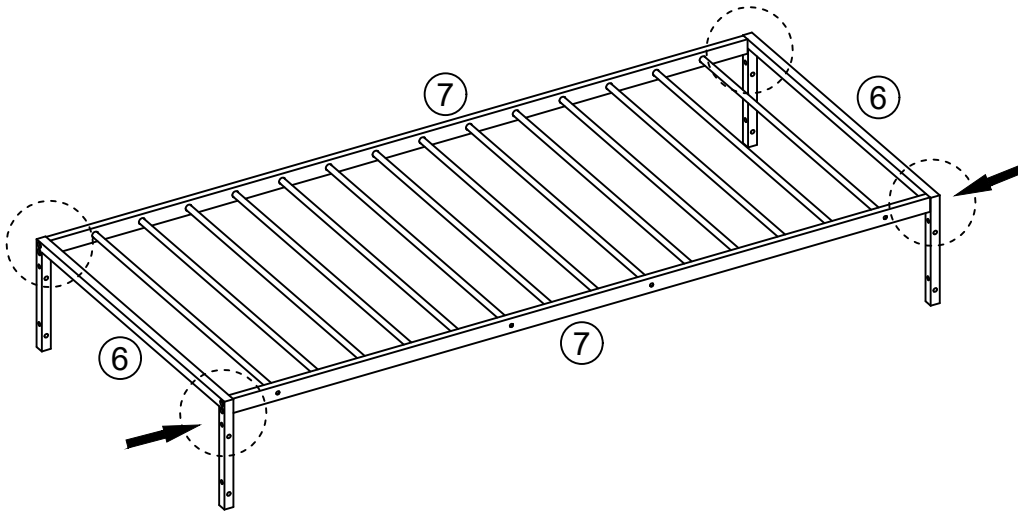

M8*45mm

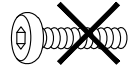

M8*40mm

5

There is a countersink in this direction

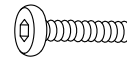
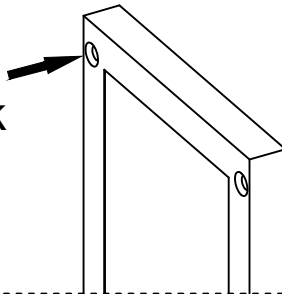

M8*40mm

(C) × 4PCS



M5

(K) × 1PC

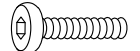
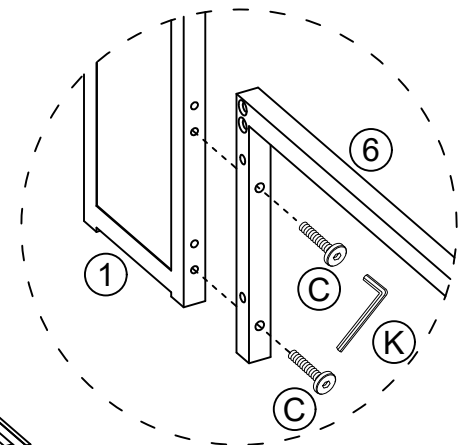
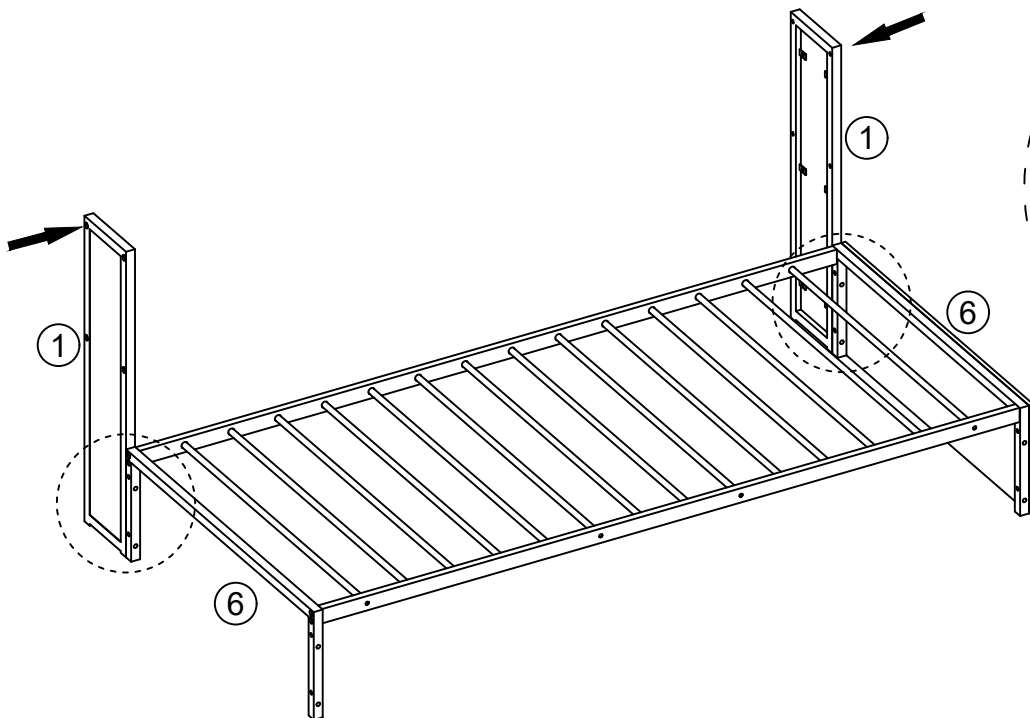



M8*40mm

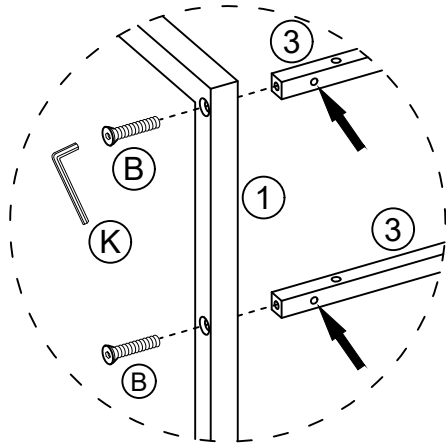

M8*45mm

6

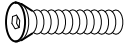

| | |
|--|--|
|  |  |
| M8*45mm | M5 |
| (B) × 4PCS | (K) × 1PC |

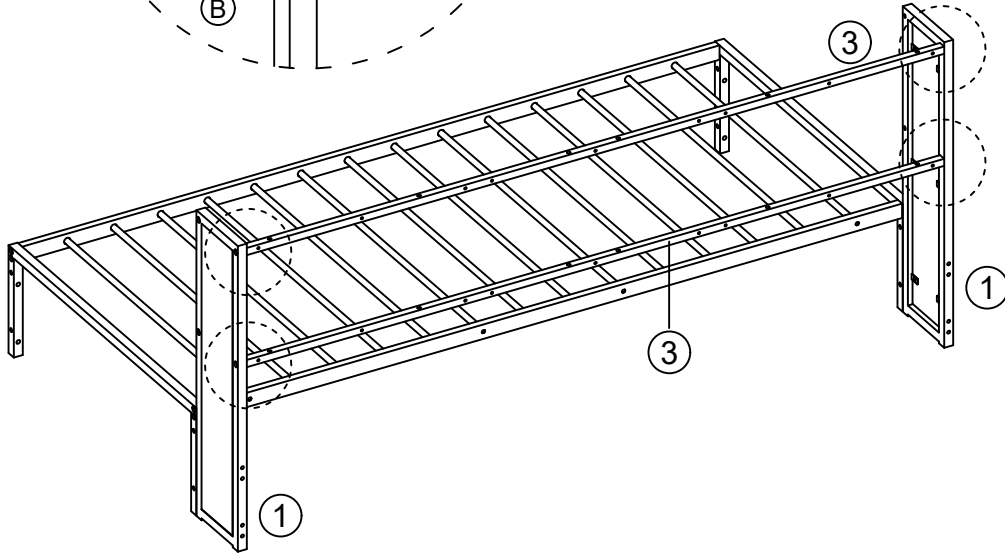

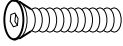
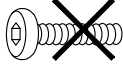
| |
|--|
|  |
| M8*45mm |
|  |
| M8*40mm |

7

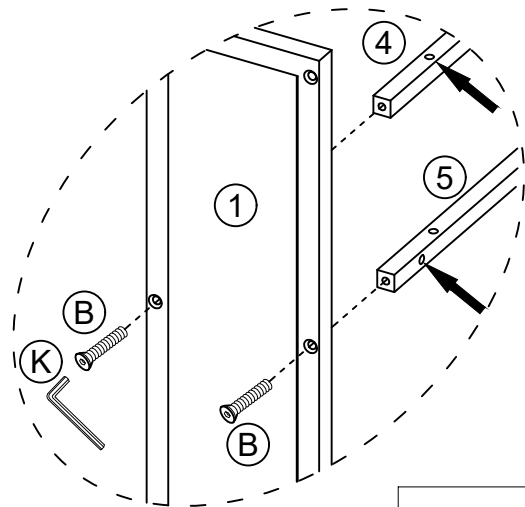
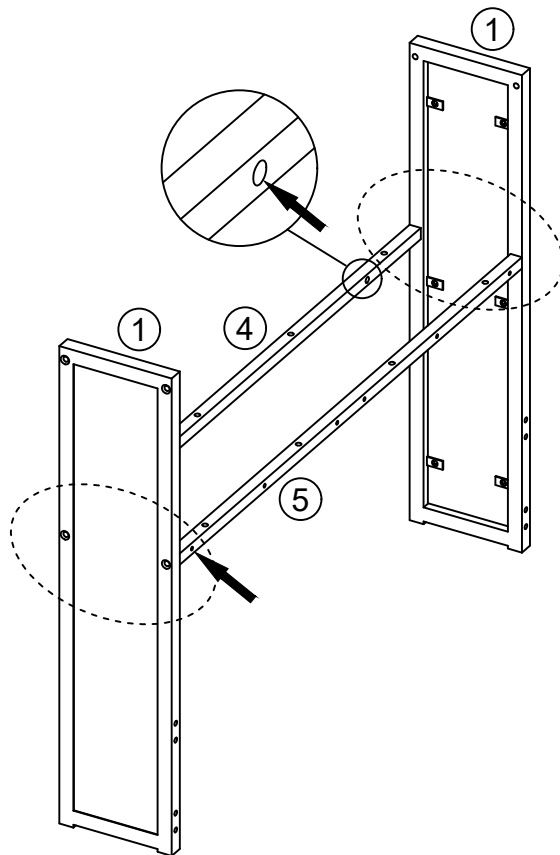

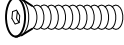
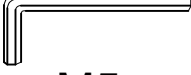
| | |
|---|---|
|  |  |
| M8*45mm | M5 |
| (B) × 4PCS | (K) × 1PC |

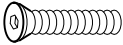
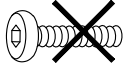
| |
|---|
|  |
| M8*45mm |
|  |
| M8*40mm |

8

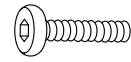

M8*40mm

(C) × 2PCS

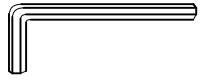

M5

(K) × 1PC

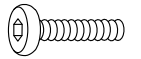
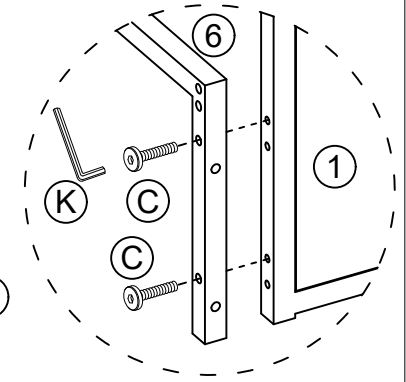
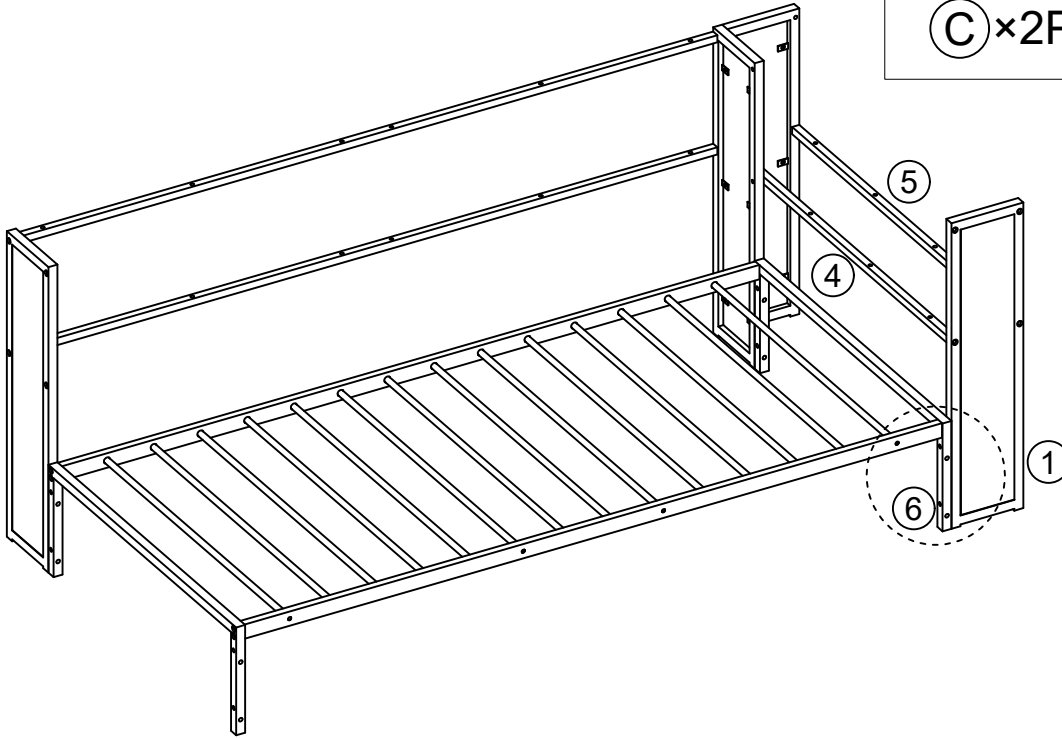

M8*40mm



M8*45mm

9

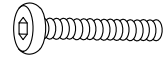

M8*60mm

(A) × 1PC



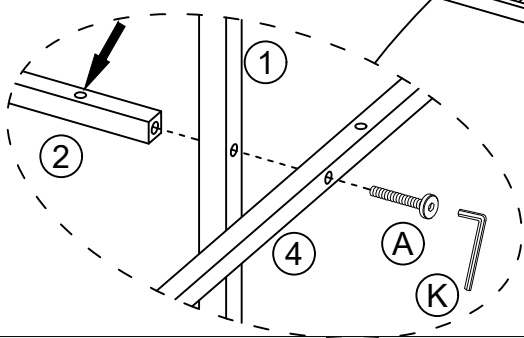
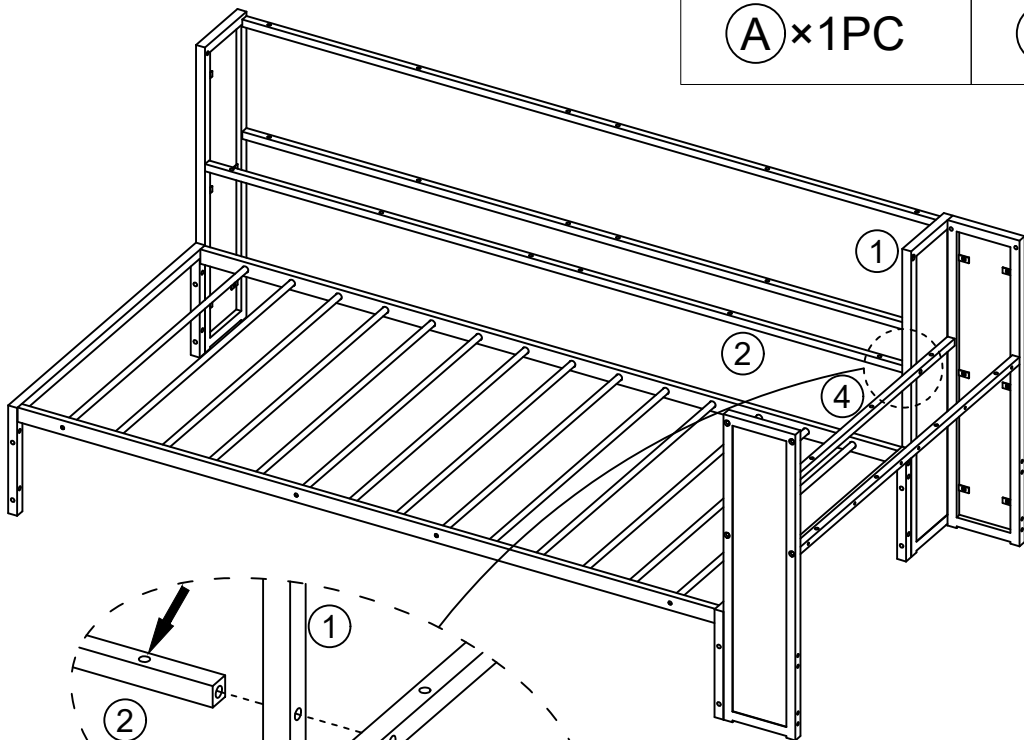

M5

(K) × 1PC

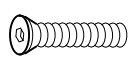

10

| | |
|--|--|
|  |  |
| M8*45mm | M5 |
| (B) × 1PC | (K) × 1PC |

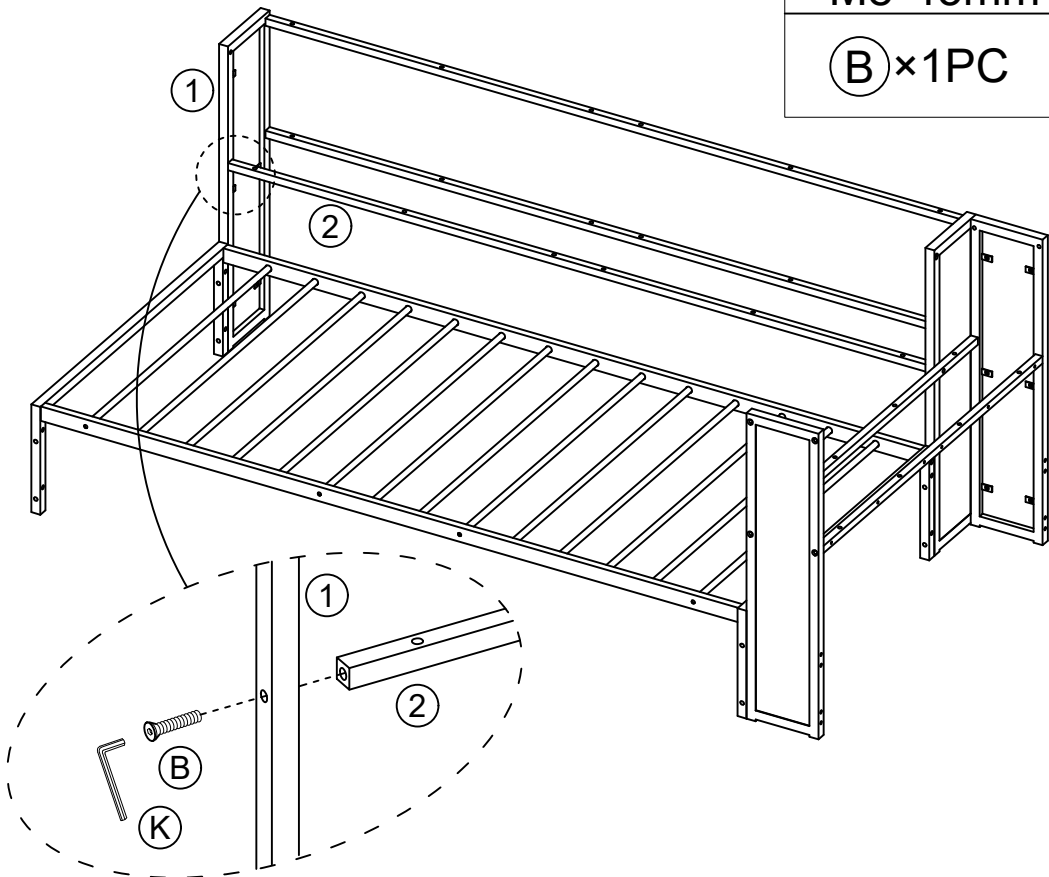

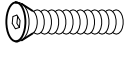
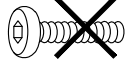
| |
|--|
|  |
| M8*45mm |
|  |
| M8*40mm |

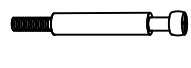
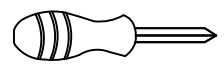

11

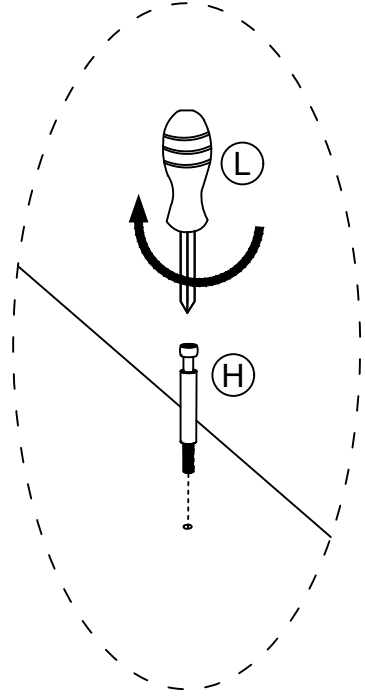
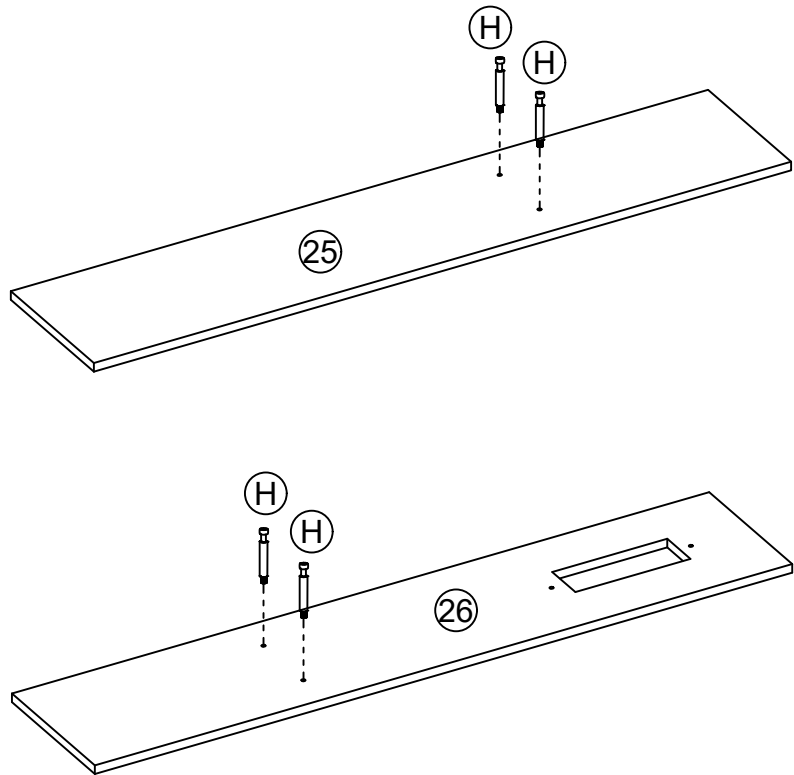
| | |
|---|---|
|  |  |
| 6*35mm | |
| (H) × 4PCS | (L) × 1PC |

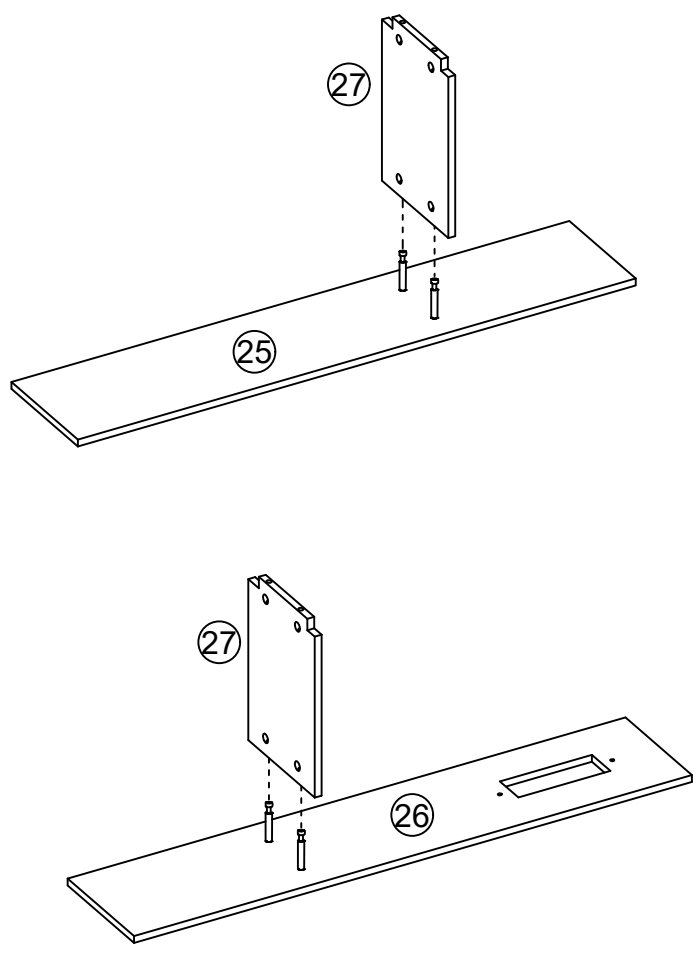

12



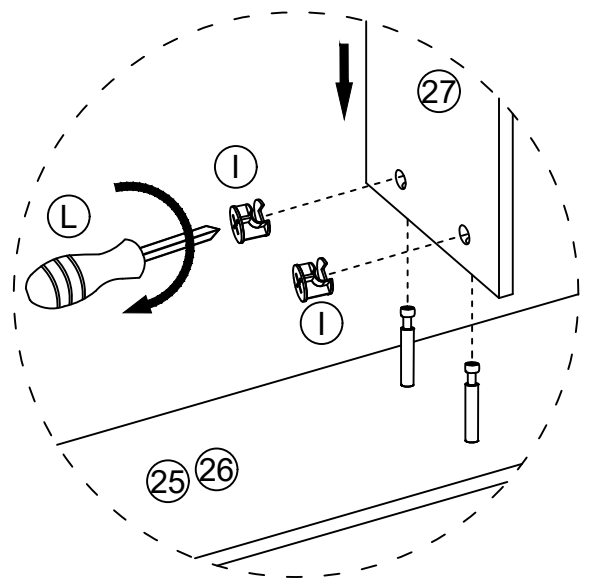

| | |
|---|---|
|  Ø15×9.5mm |  |
| (I) × 4PCS | (L) × 1PC |



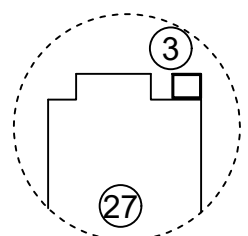
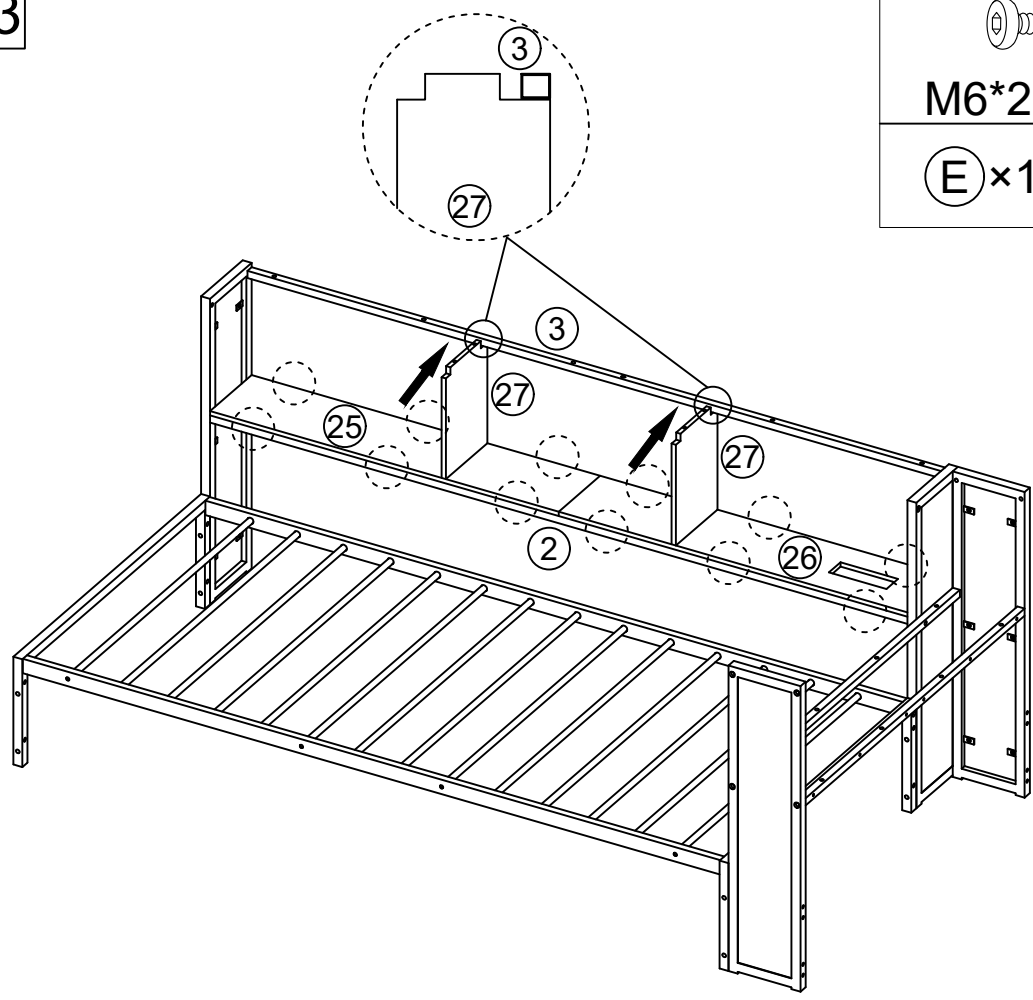

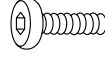
13

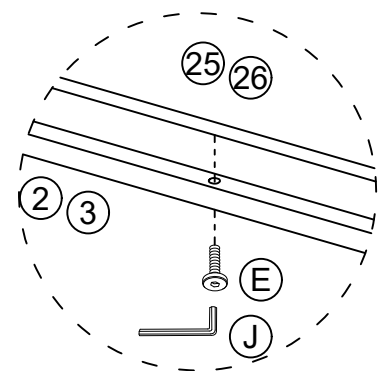

| | |
|--|---|
|  M6*28mm |  M4 |
| (E) × 12PCS | (J) × 1PC |

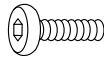
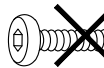

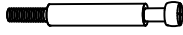

| |
|--|
|  M6*28mm |
|  M6*35mm |

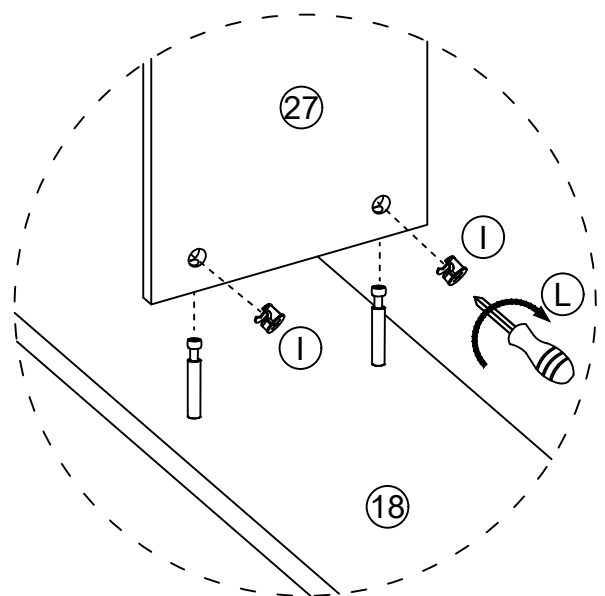
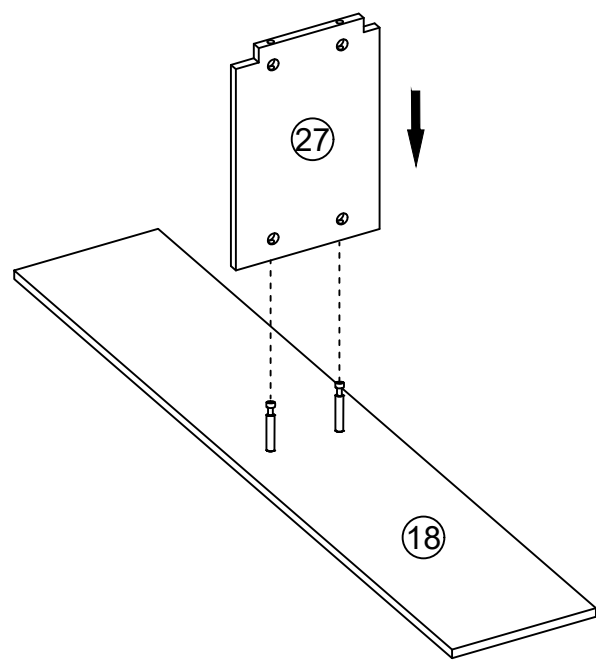
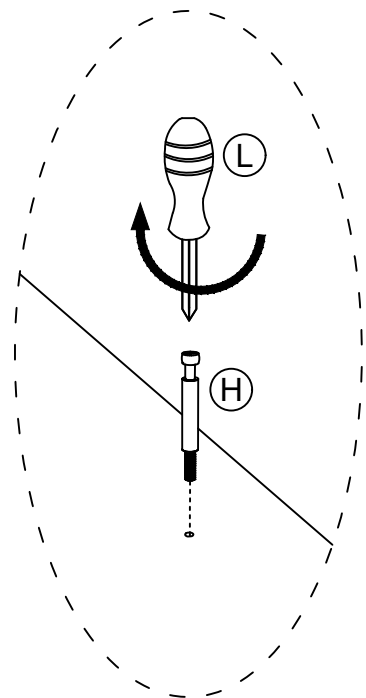
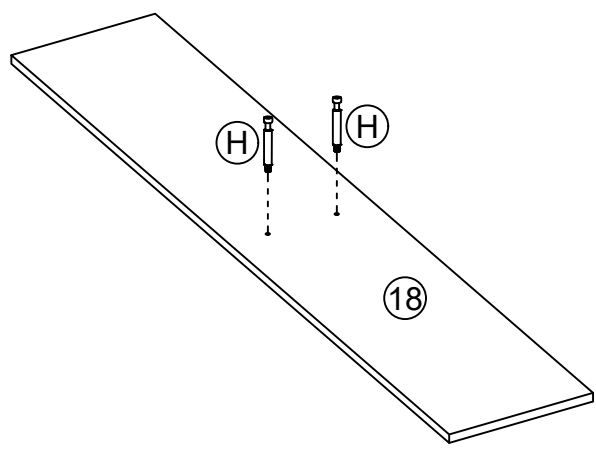
| | | |
|---|---|---|
|  6*35mm |  Ø15*9.5mm |  |
| (H) × 2PCS | (I) × 2PCS | (L) × 1PC |



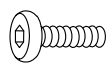

15

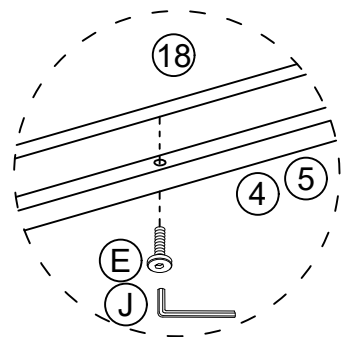
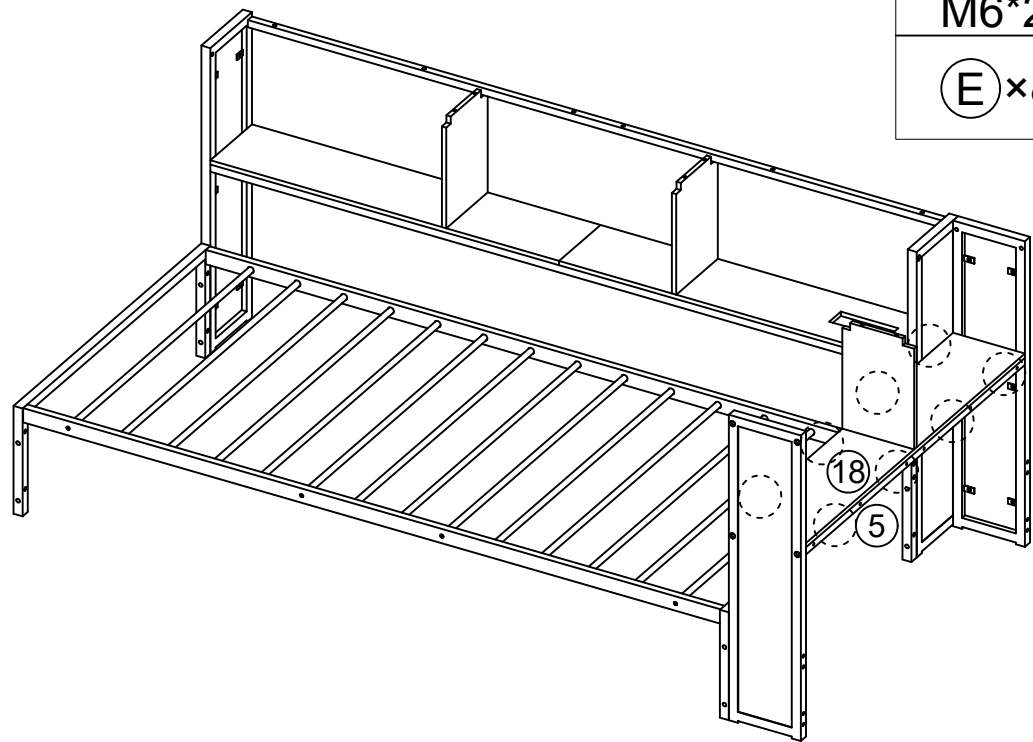
| | |
|--|--|
|  |  |
| M6*28mm | M4 |
| (E) × 8PCS | (J) × 1PC |

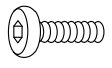
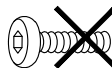

| | |
|---|--------------------|
|  | M6*28mm |
|  | M6*35mm |

16

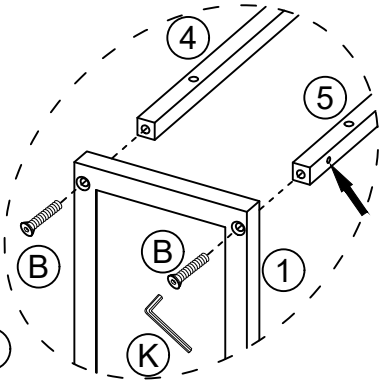
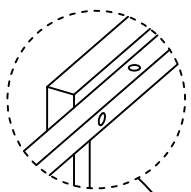
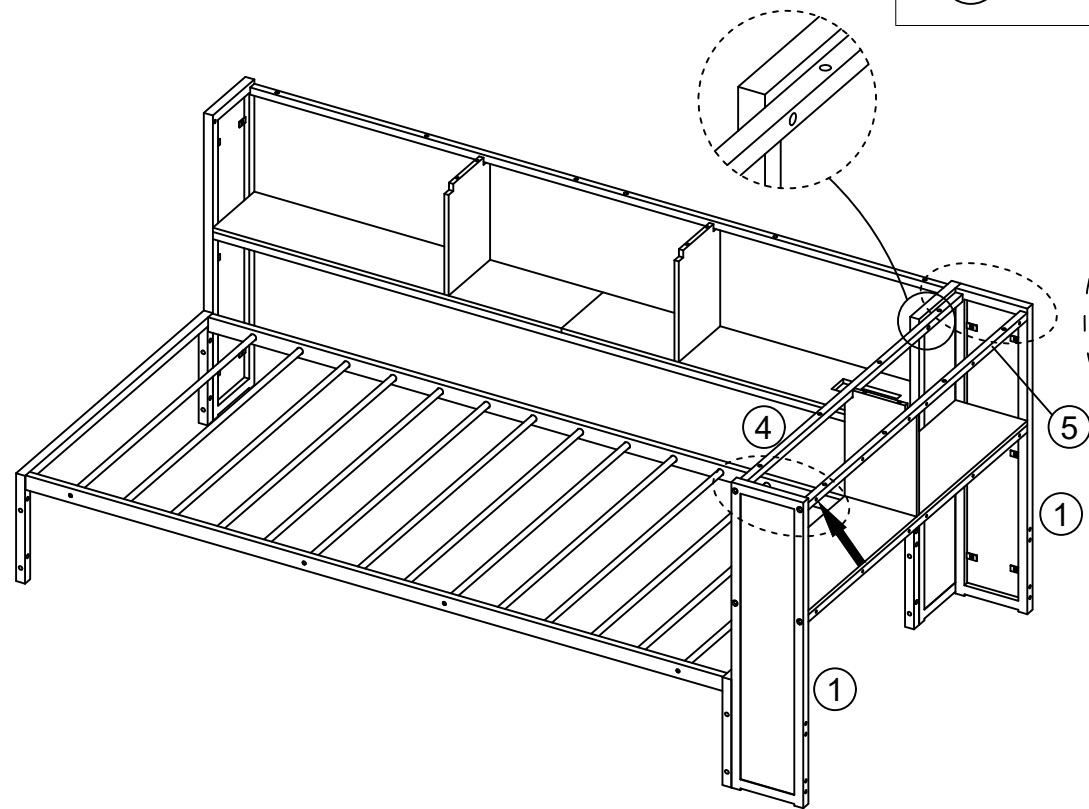

| | |
|---|---|
|  |  |
| M8*45mm | M5 |
| (B) × 4PCS | (K) × 1PC |

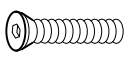
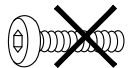

| | |
|--|--------------------|
|  | M8*45mm |
|  | M8*40mm |

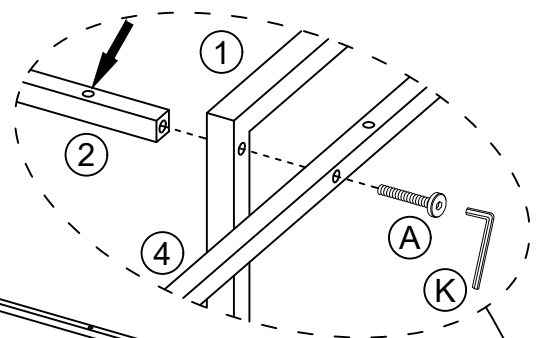
17

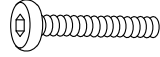

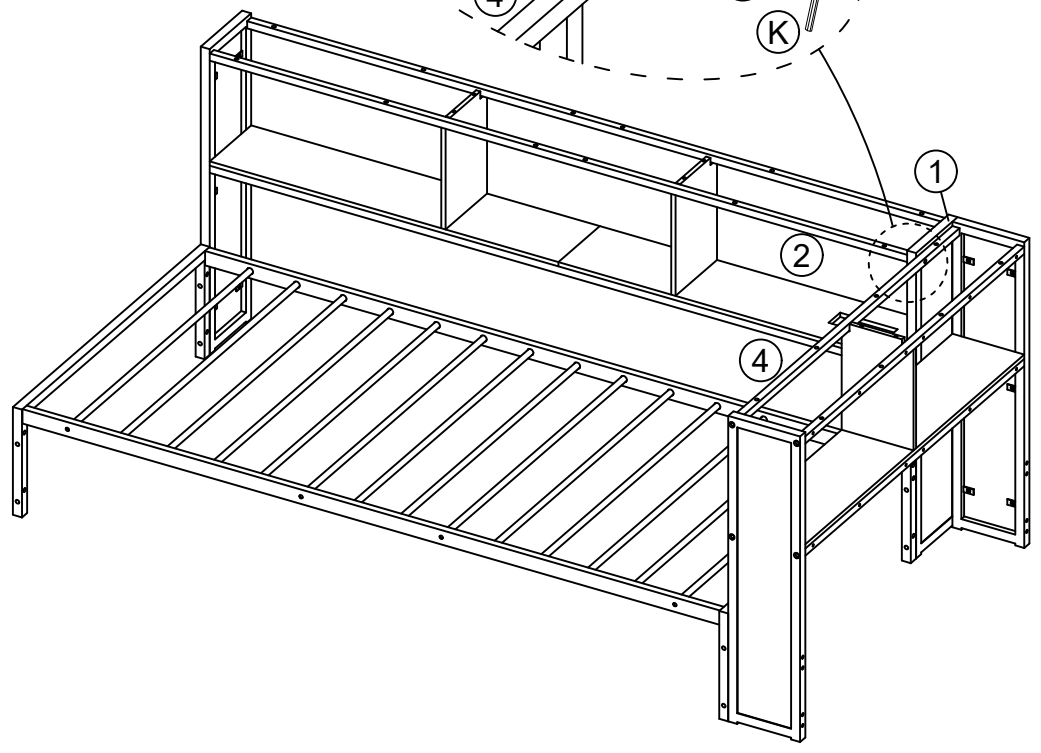

| | |
|--|--|
|  |  |
| M8*60mm | M5 |
| (A) × 1PC | (K) × 1PC |

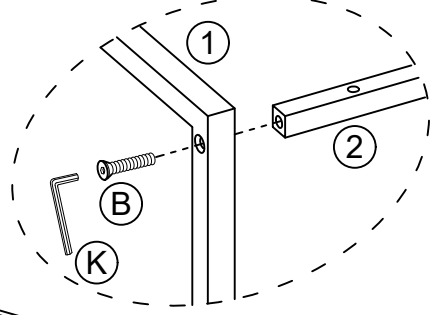

18

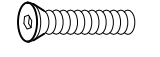

| | |
|---|---|
|  |  |
| M8*45mm | M5 |
| (B) × 1PC | (K) × 1PC |

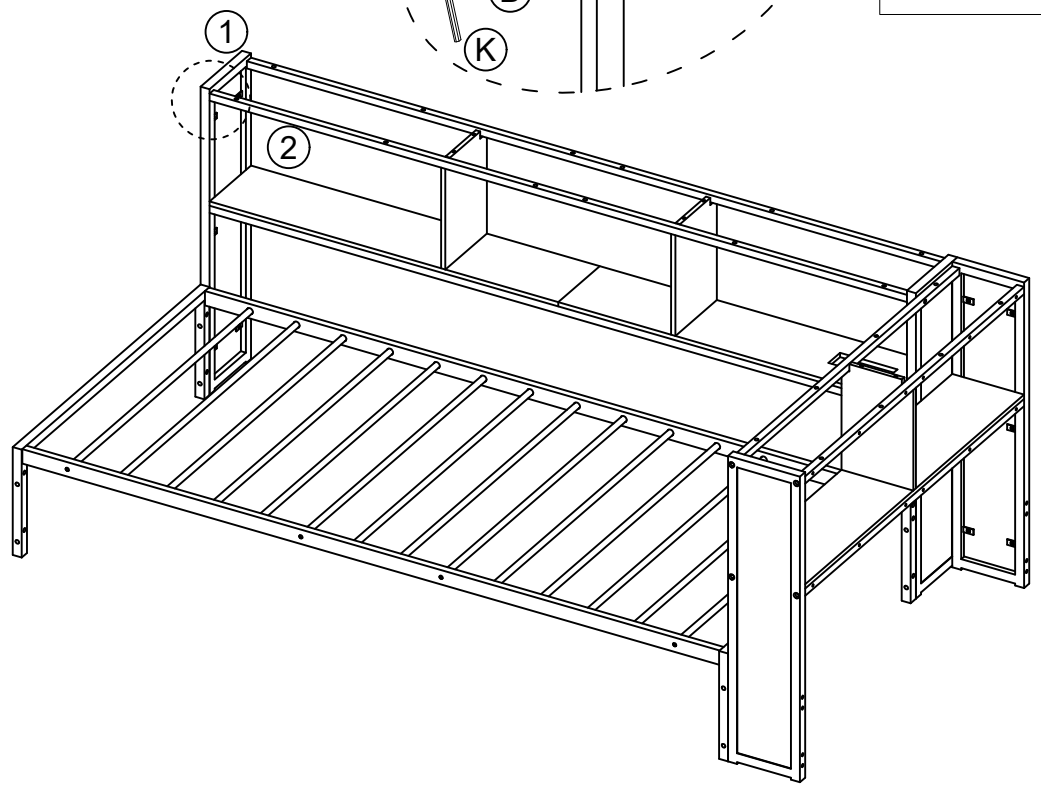

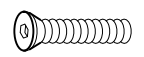
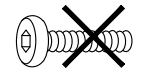
| |
|---|
|  |
| M8*45mm |
|  |
| M8*40mm |

19

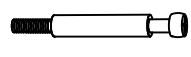

6*35mm

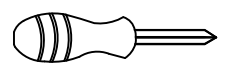

(H) x 6PCS

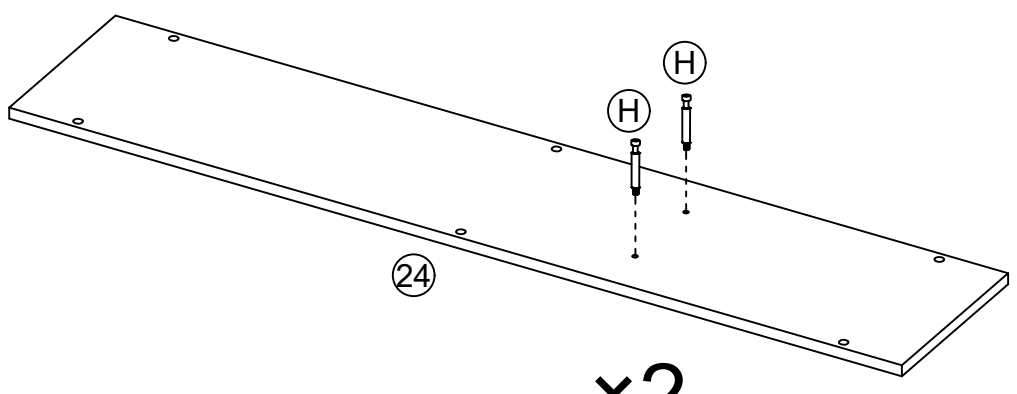
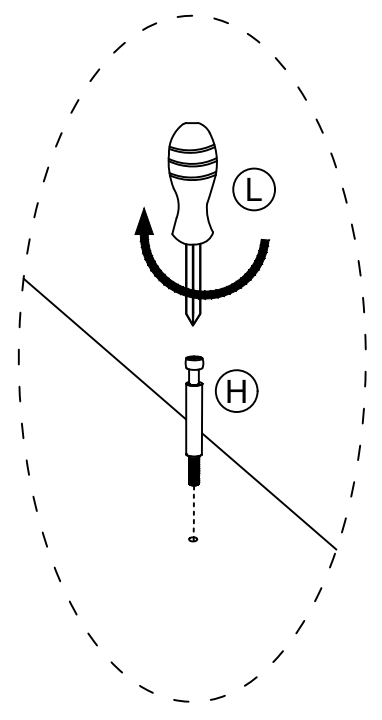
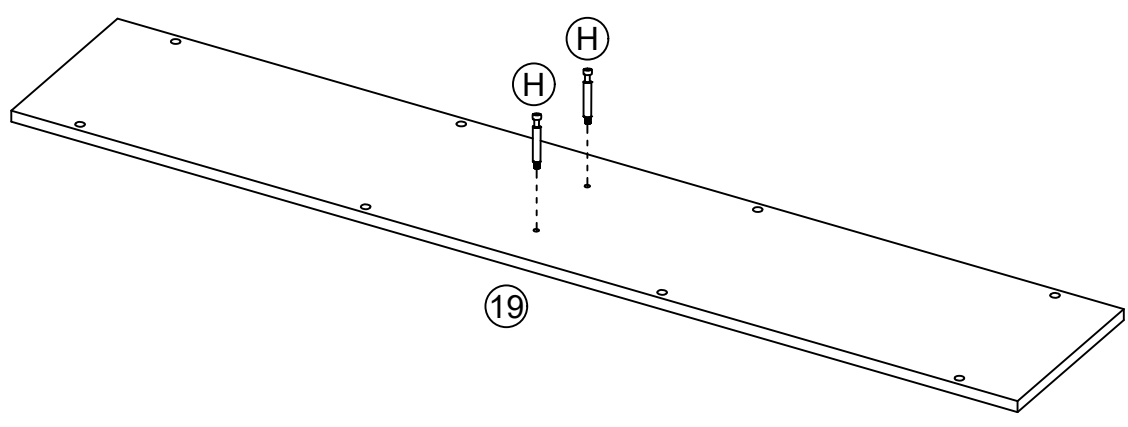

(L) x 1PC

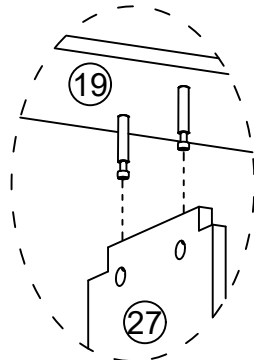

x2

20

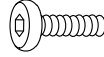

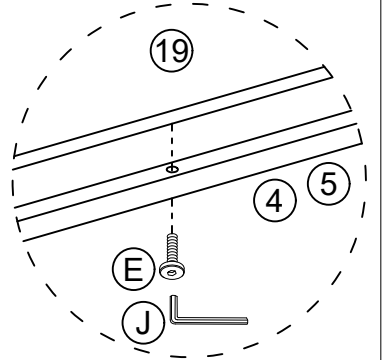
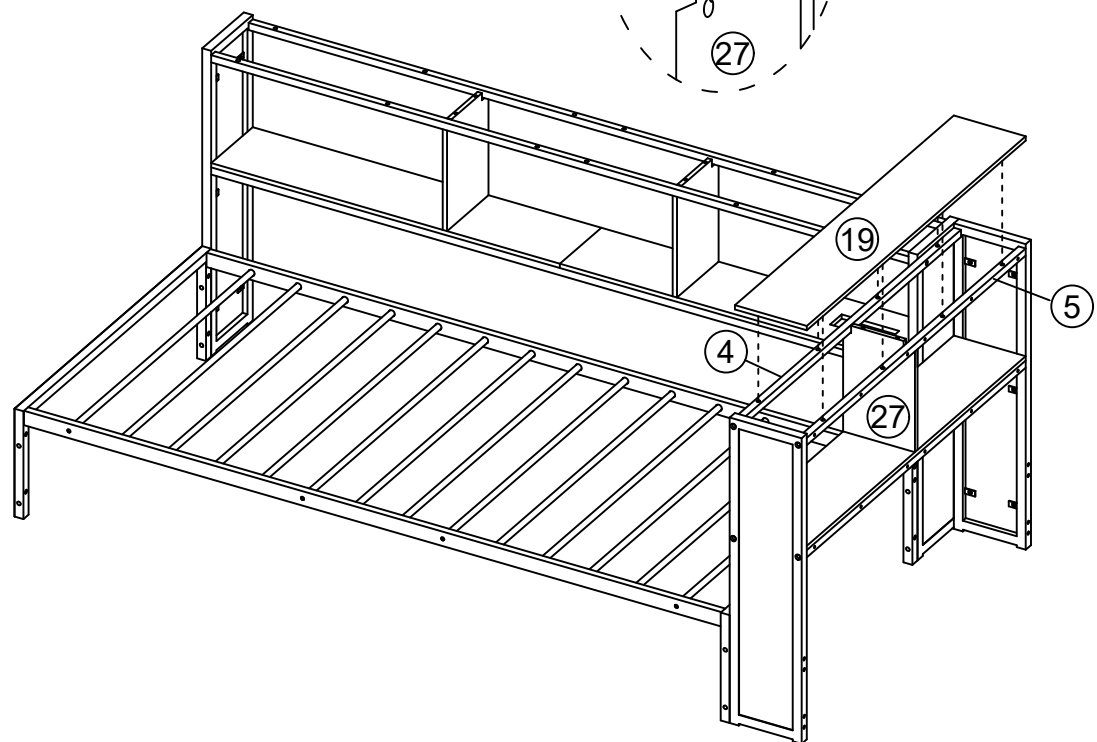

| | |
|--|--|
|  |  |
| M6*28mm | M4 |
| (E) × 8PCS | (J) × 1PC |

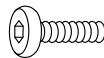
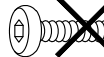

| |
|---|
|  |
| M6*28mm |
|  |
| M6*35mm |

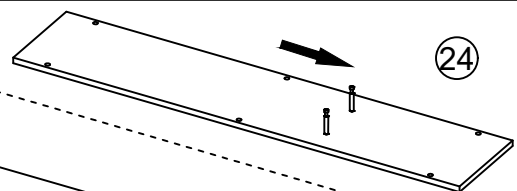
21

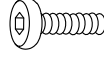

| | |
|---|---|
|  |  |
| M6*28mm | M4 |
| (E) × 12PCS | (J) × 1PC |

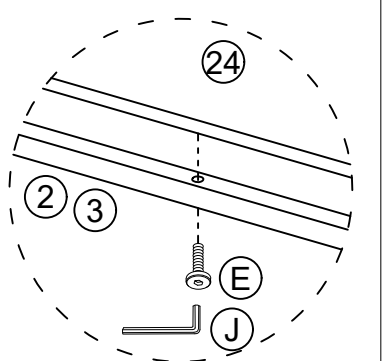
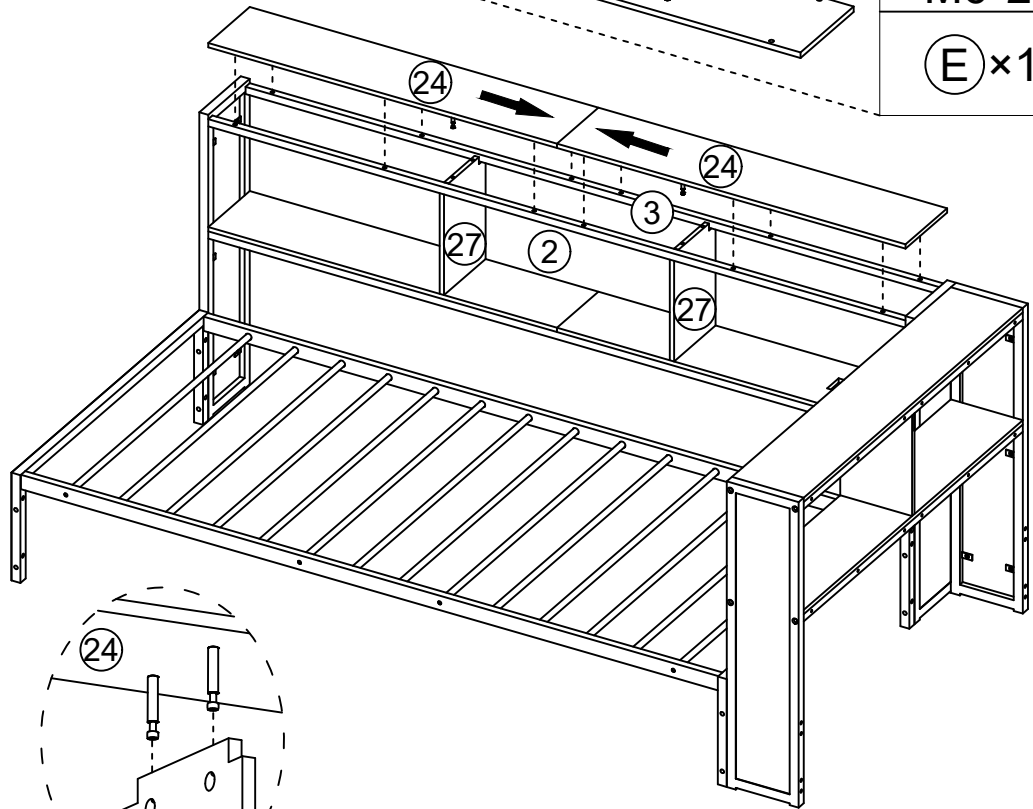

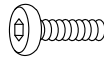
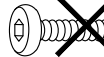
| |
|--|
|  |
| M6*28mm |
|  |
| M6*35mm |

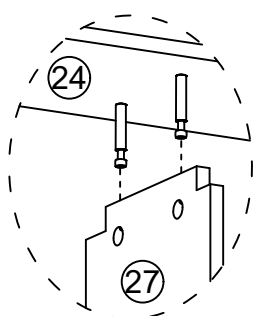

22



Ø15×9.5mm

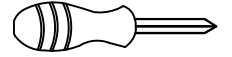

Ⓢ×6PCS

Ⓛ×1PC

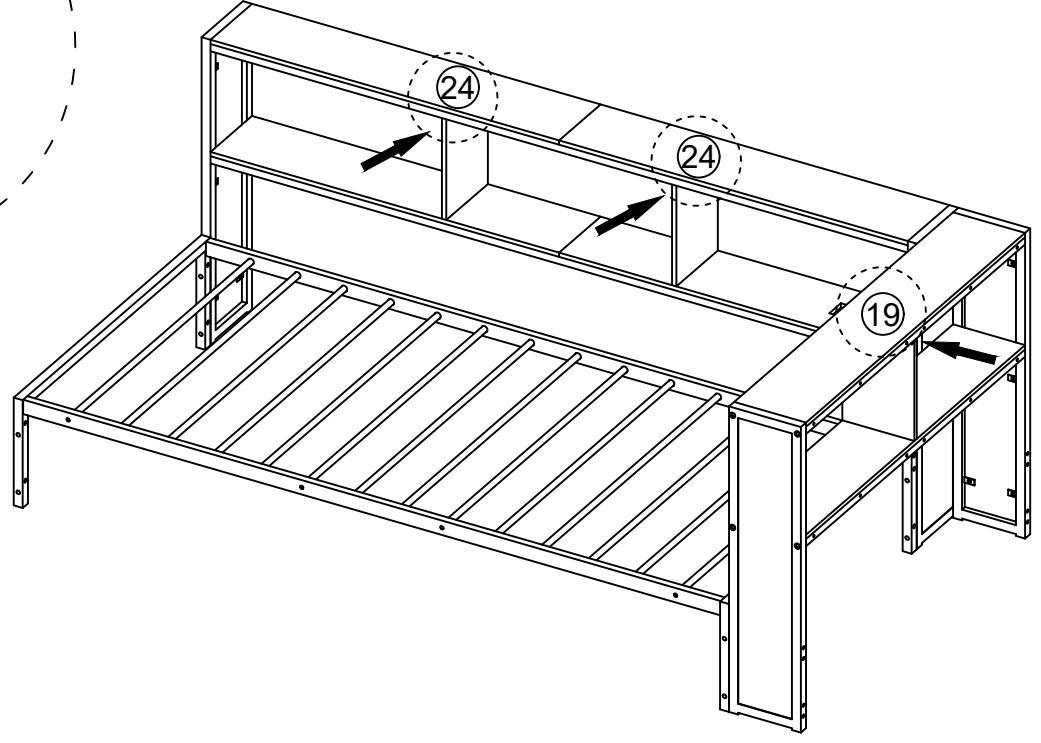
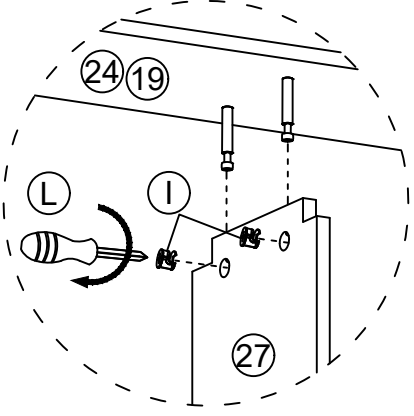

23



M6*15mm

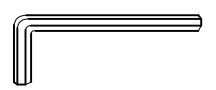

M4

ⓕ×30PCS

ⓙ×1PC

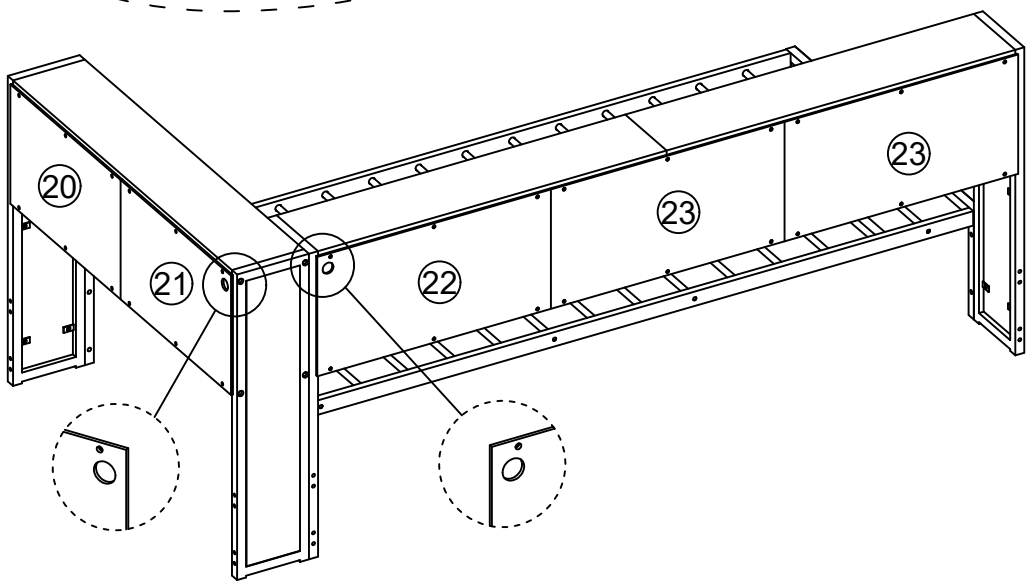
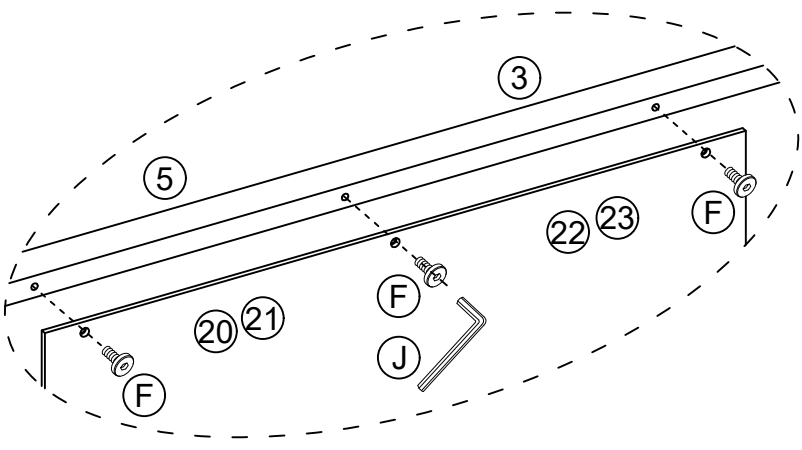

M6*15mm

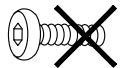

M6*28mm

24

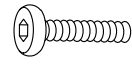

M6*35mm

(D) × 4PCS



M4

(J) × 1PC

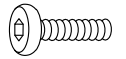
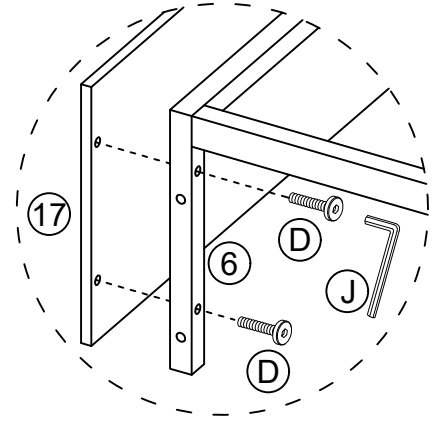
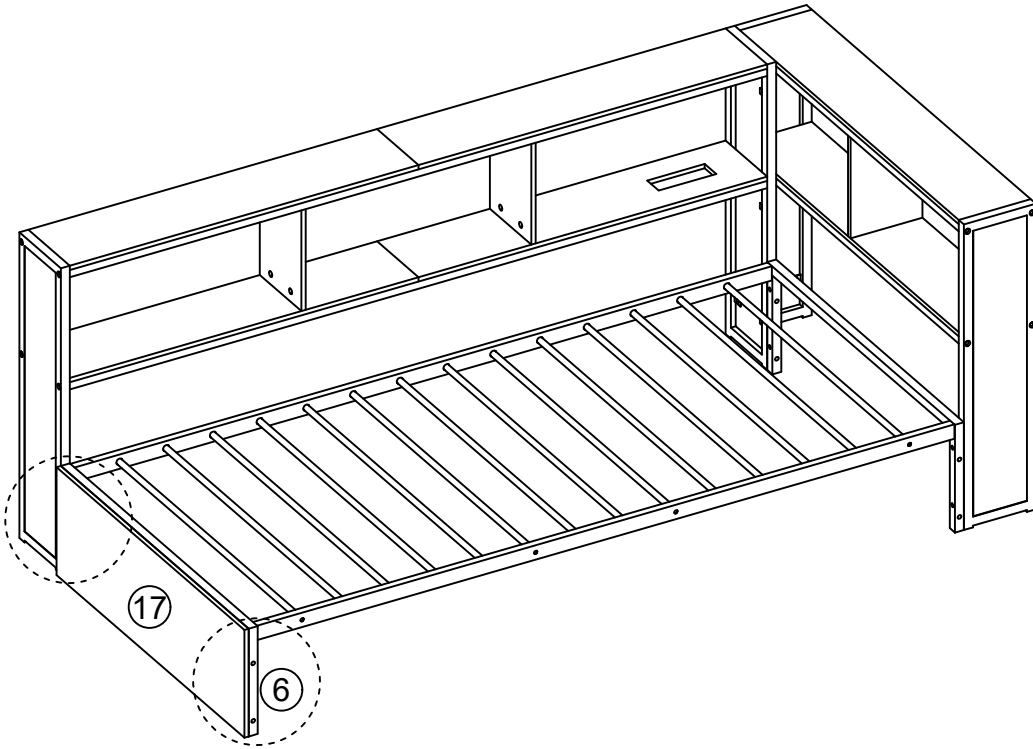

M6*35mm

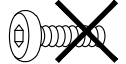

M6*28mm



(M) × 12PCS

25

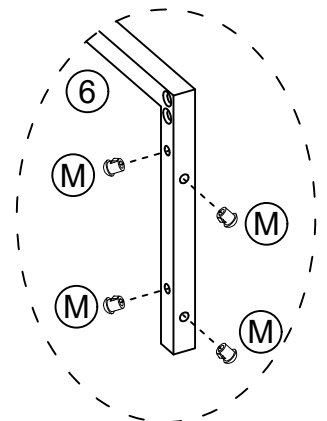
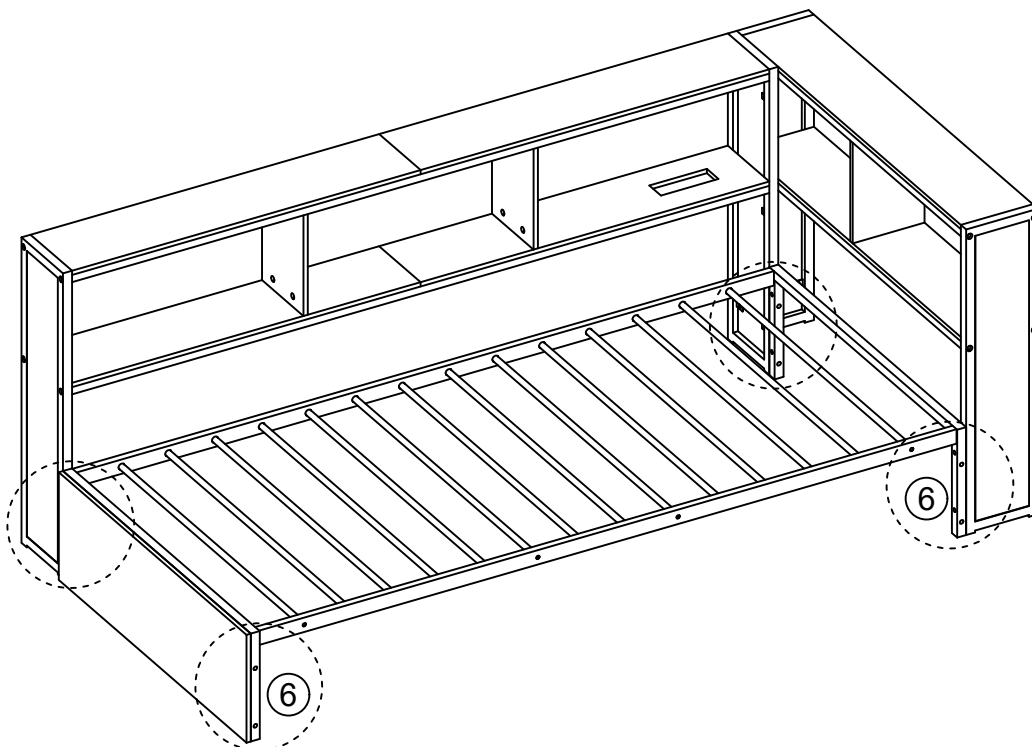

26



M6*15mm

(F) × 8PCS



M4

(J) × 1PC

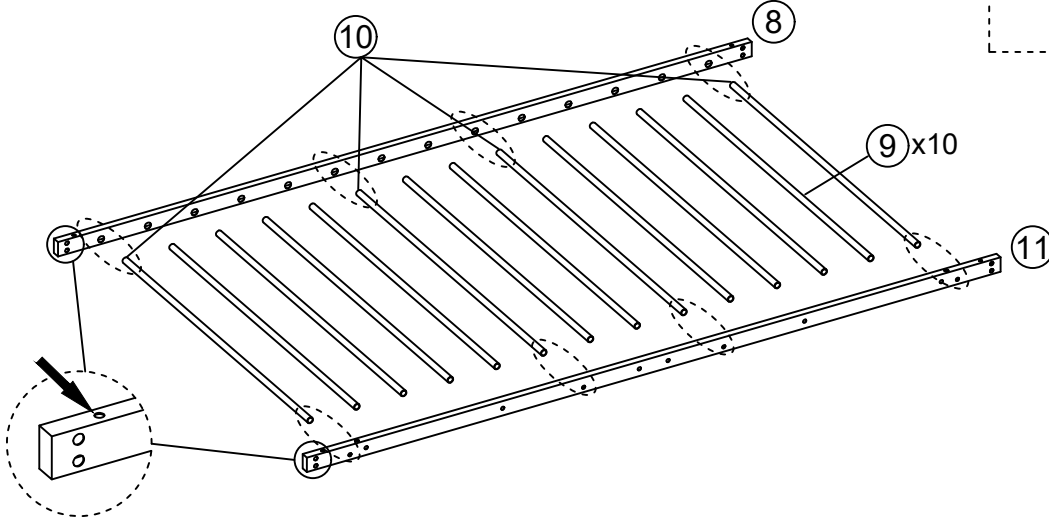
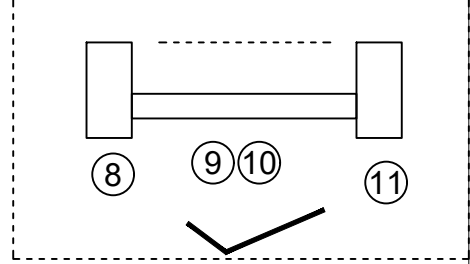
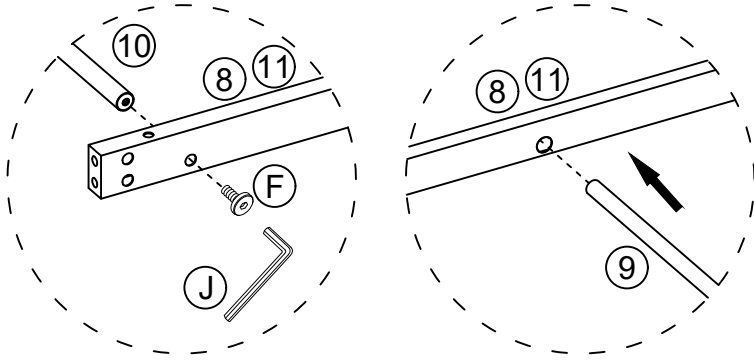

M6*15mm

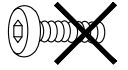

M6*28mm

27

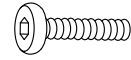

M8*40mm

(C) × 8PCS



M5

(K) × 1PC

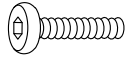
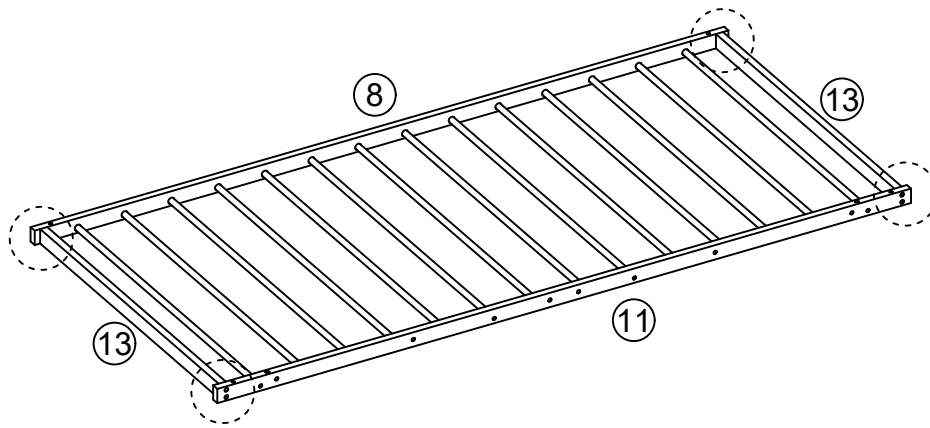
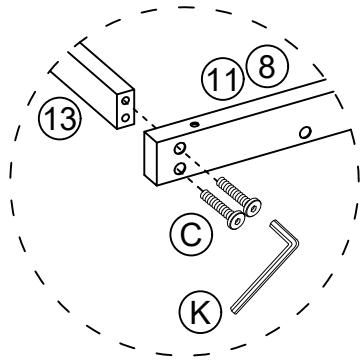

M8*40mm

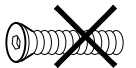

M8*45mm

28

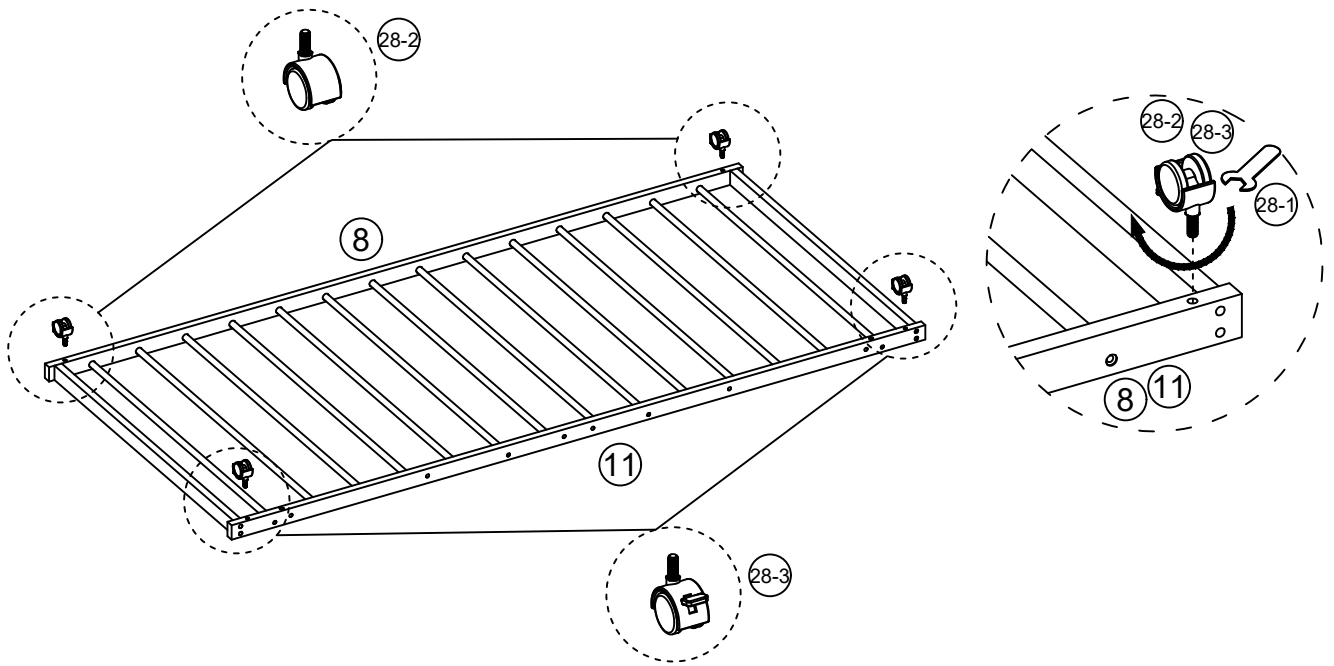

29

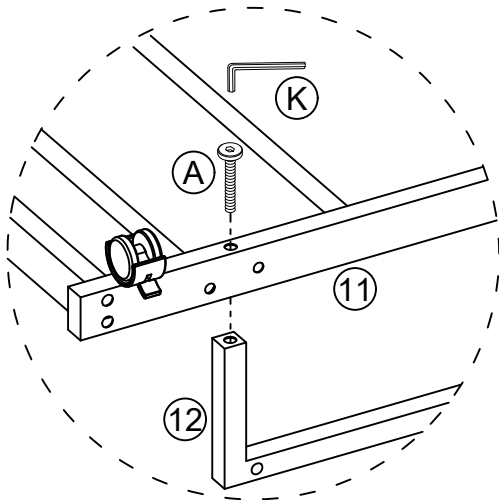

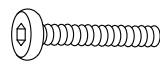
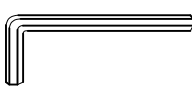

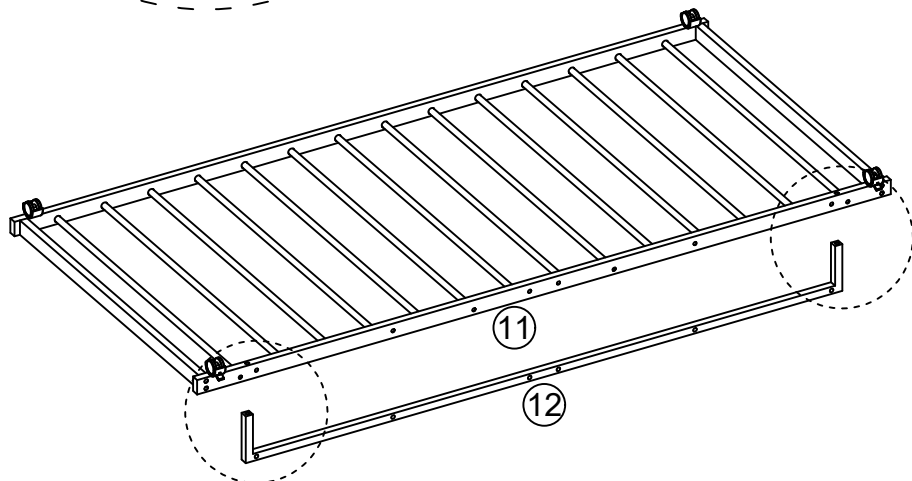

| | |
|---|---|
|  |  |
| M8*60mm | M5 |
| (A) × 2PC | (K) × 1PC |

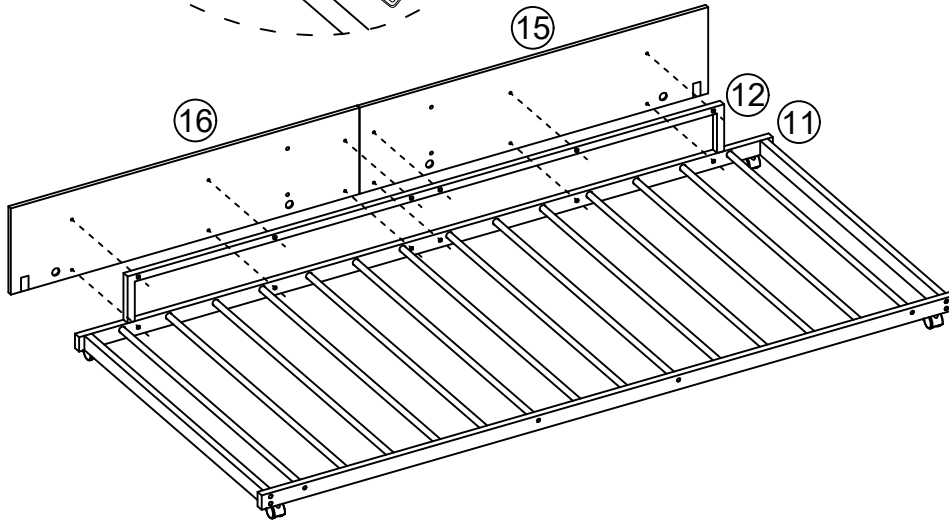
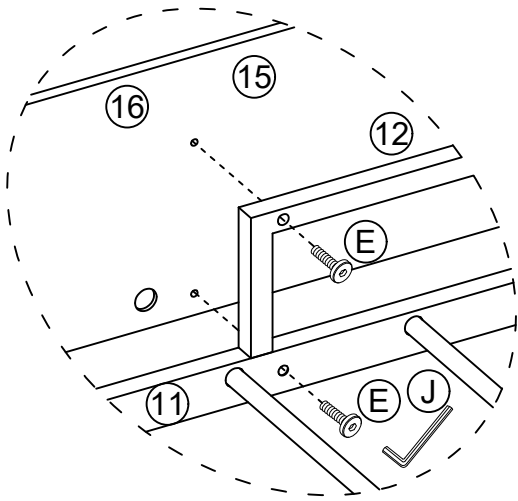

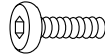
30



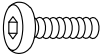

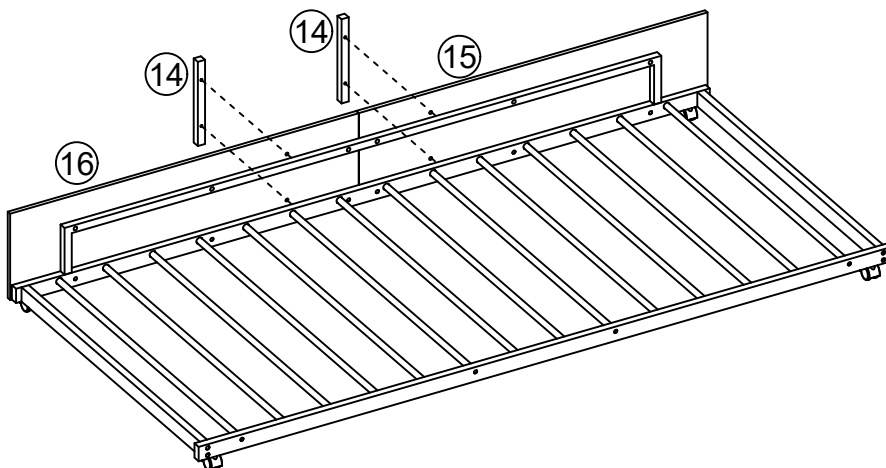
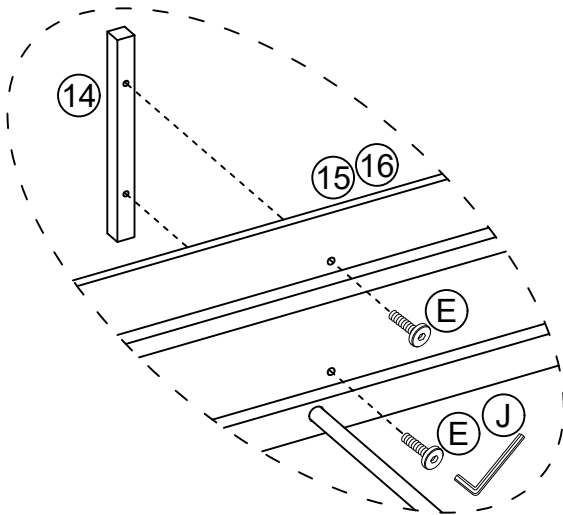

| | |
|--|--|
|  |  |
| M6*28mm | M4 |
| (E) × 12PCS | (J) × 1PC |

| |
|---|
|  |
| M6*28mm |
|  |
| M6*35mm |

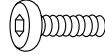
31

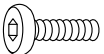

| | |
|---|---|
|  |  |
| M6*28mm | M4 |
| (E) × 4PCS | (J) × 1PC |

| |
|--|
|  |
| M6*28mm |
|  |
| M6*35mm |

32

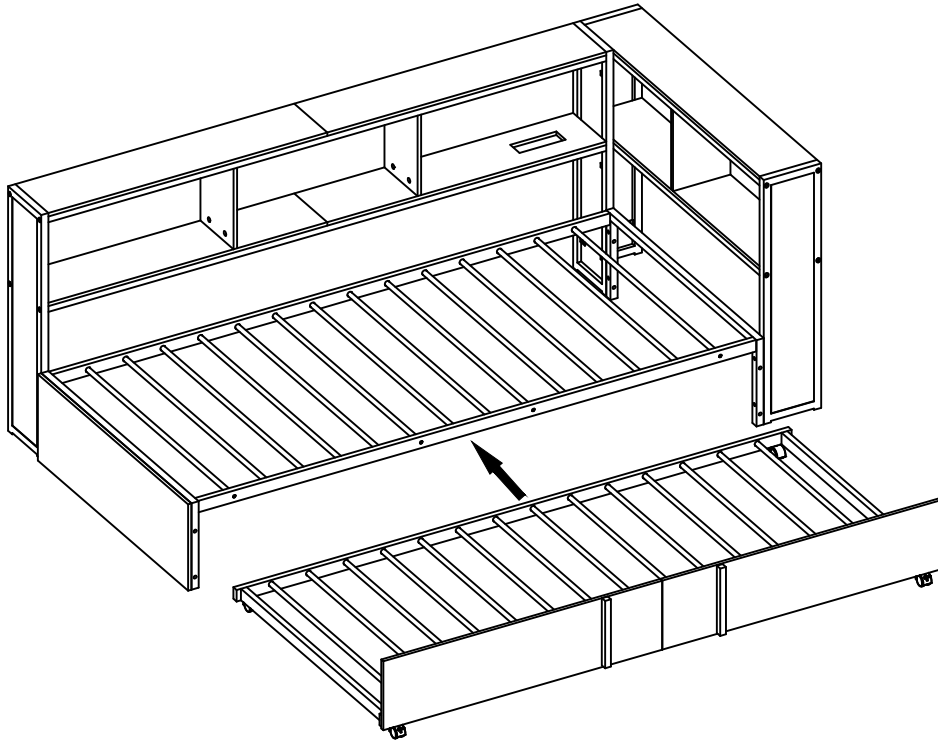

33

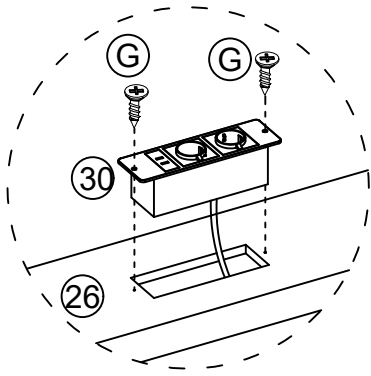

M3*12mm

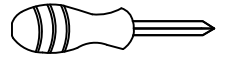

(G) × 2PCS

(L) × 1PC

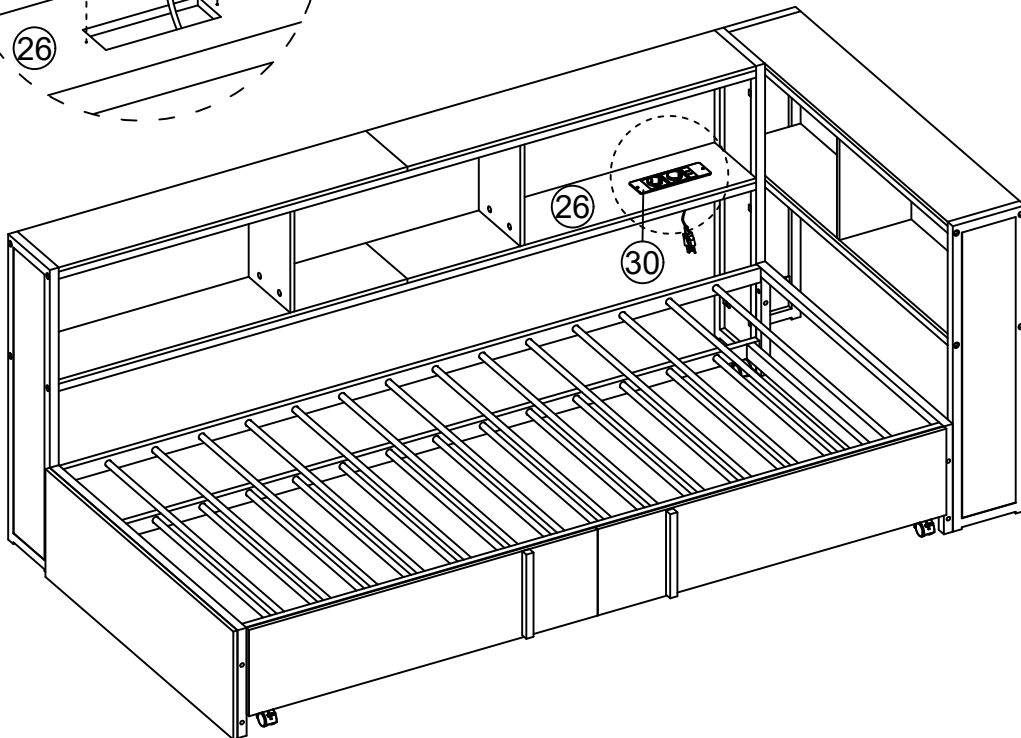

34

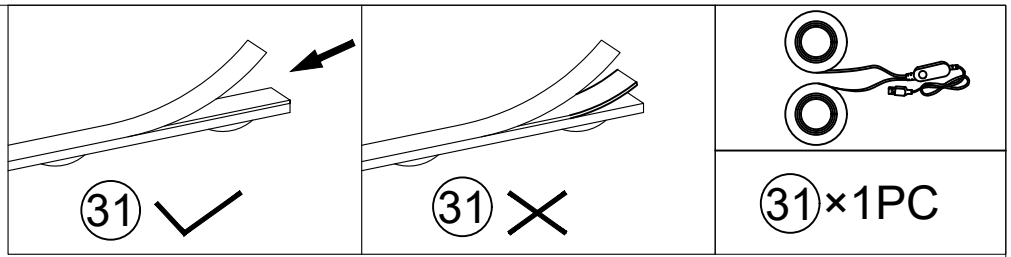

The light strip has long and short.

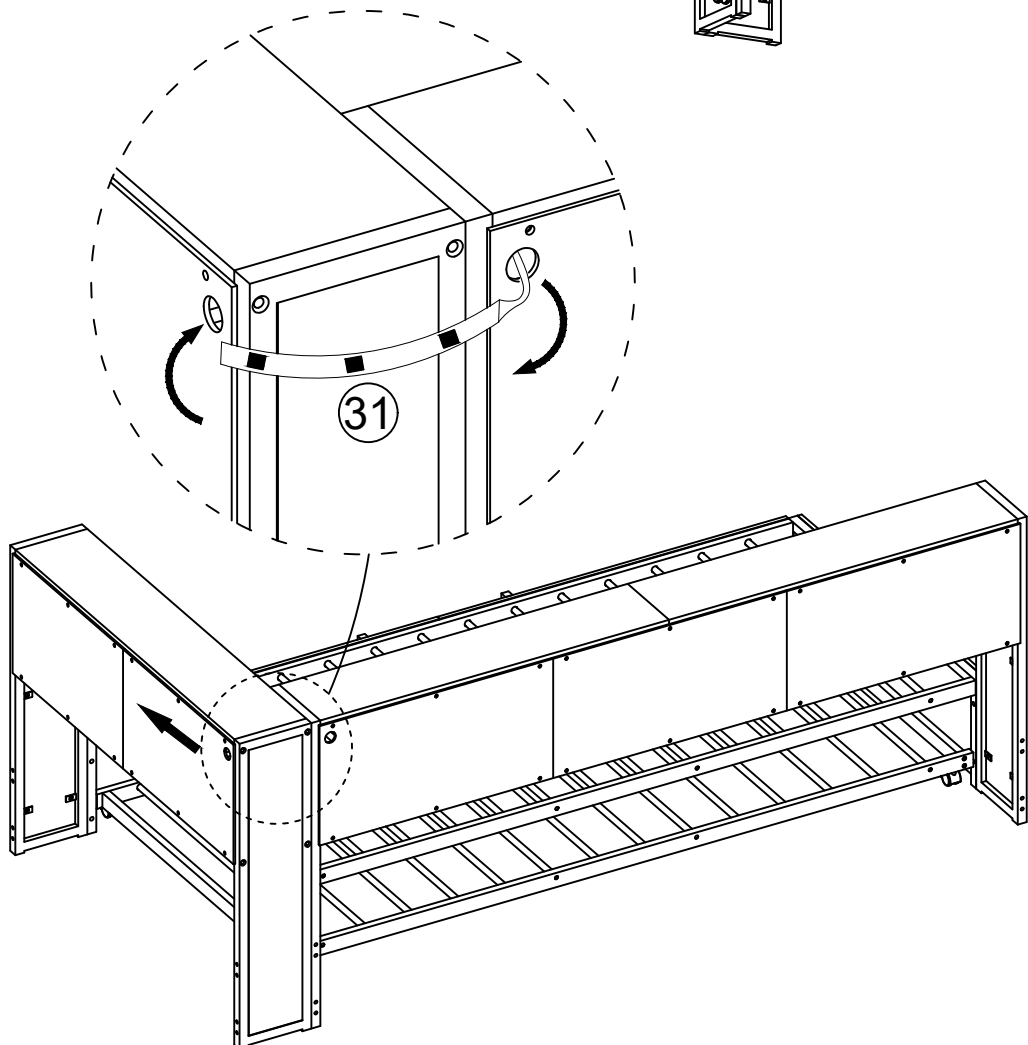
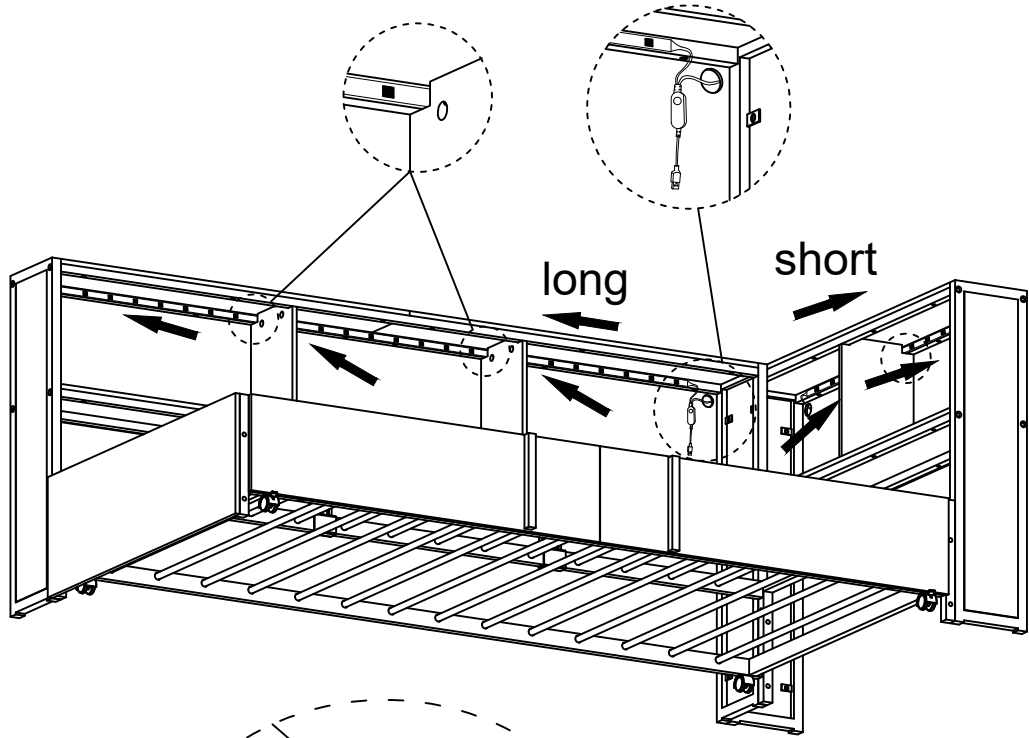

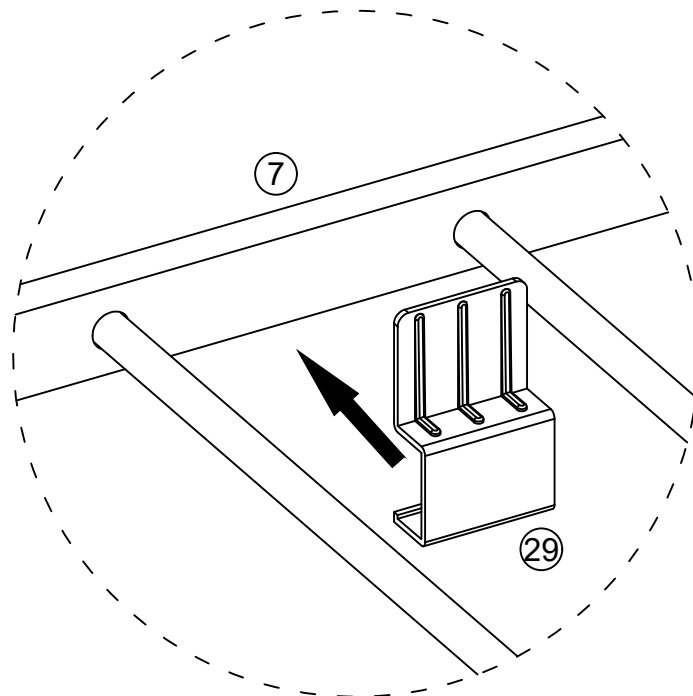
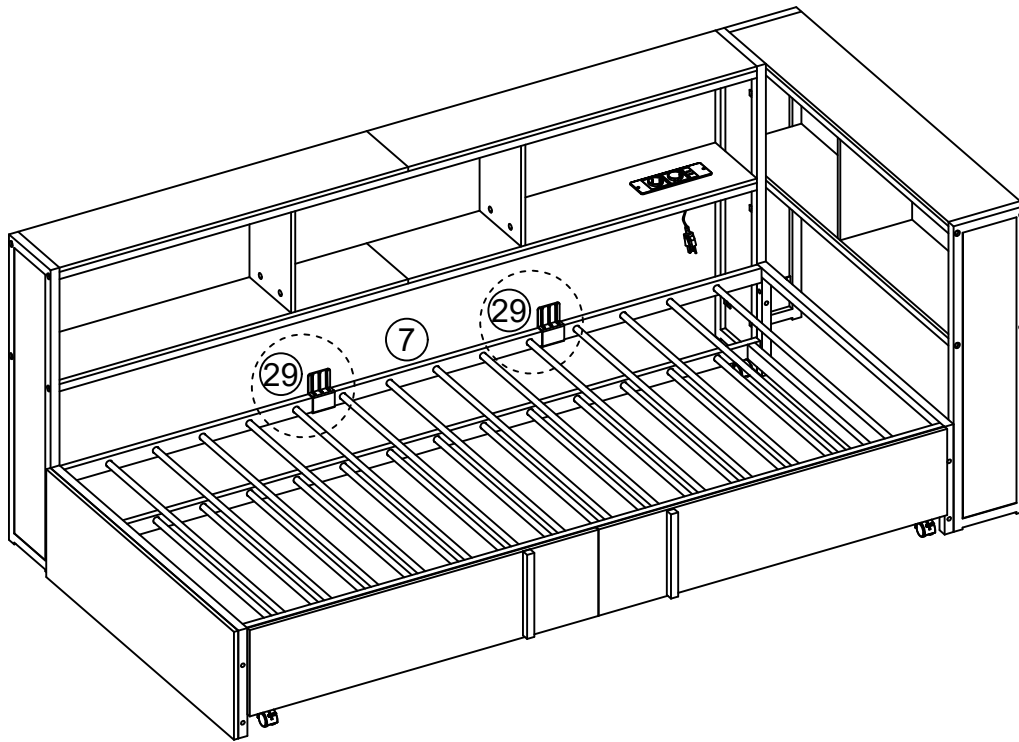

36

B

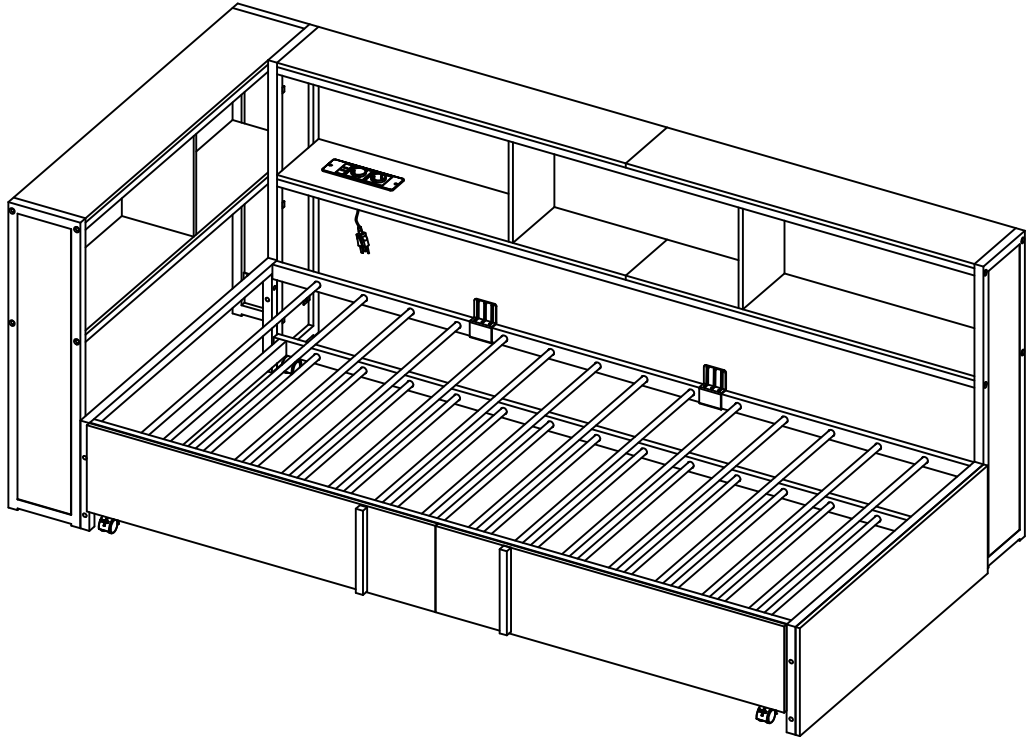

37

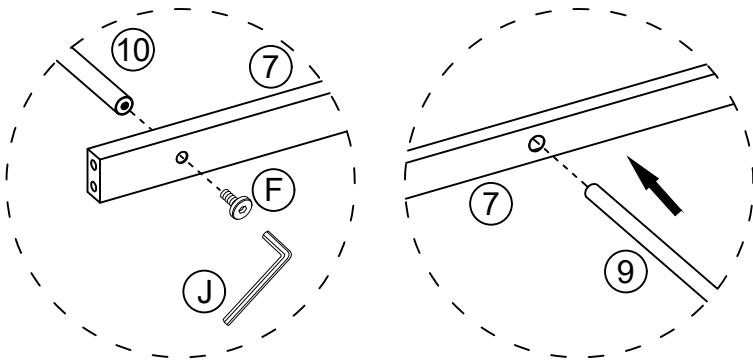

M6*15mm

(F) x 8PCS

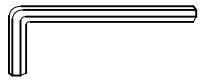

M4

(J) x 1PC

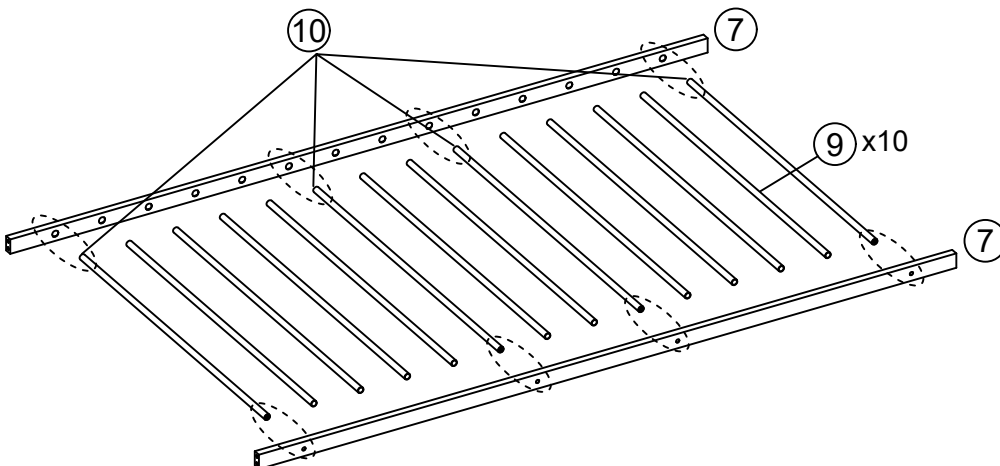

M6*15mm

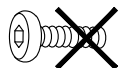

M6*28mm

38

There is a countersink in this direction

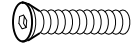
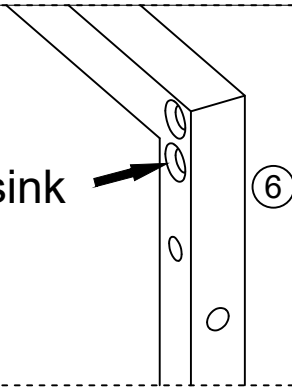

M8*45mm

(B) × 8PCS



M5

(K) × 1PC

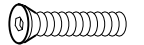
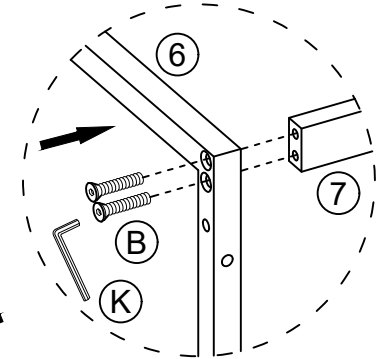
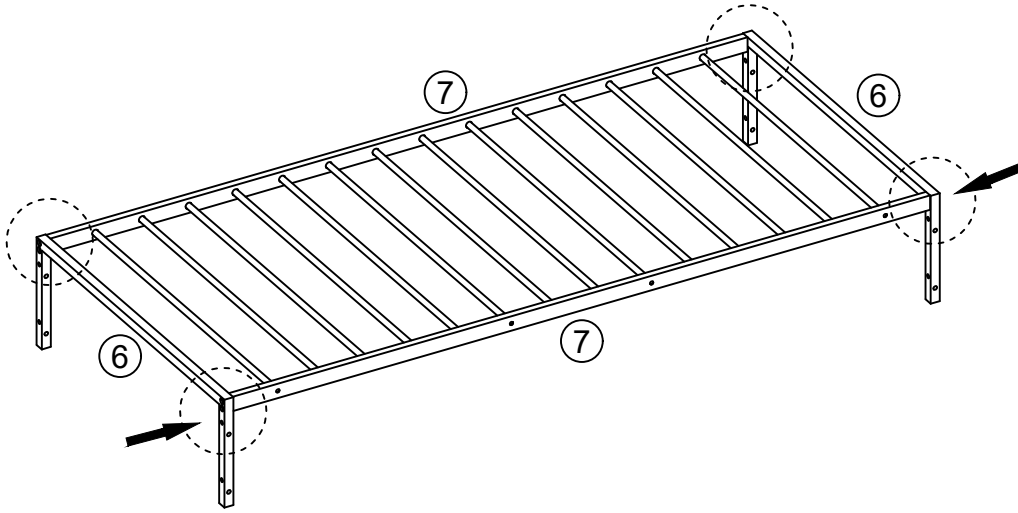

M8*45mm

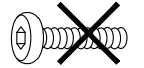

M8*40mm

39

There is a countersink in this direction

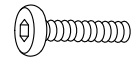
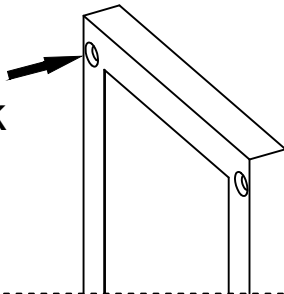

M8*40mm

(C) × 4PCS



M5

(K) × 1PC

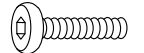
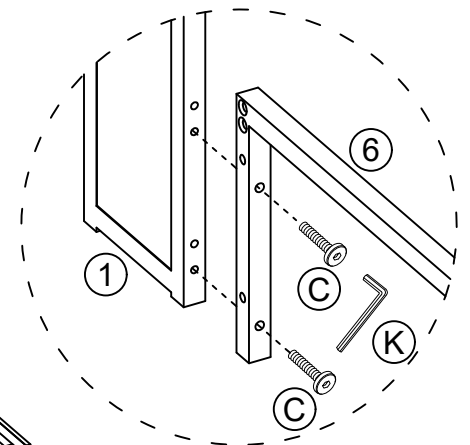
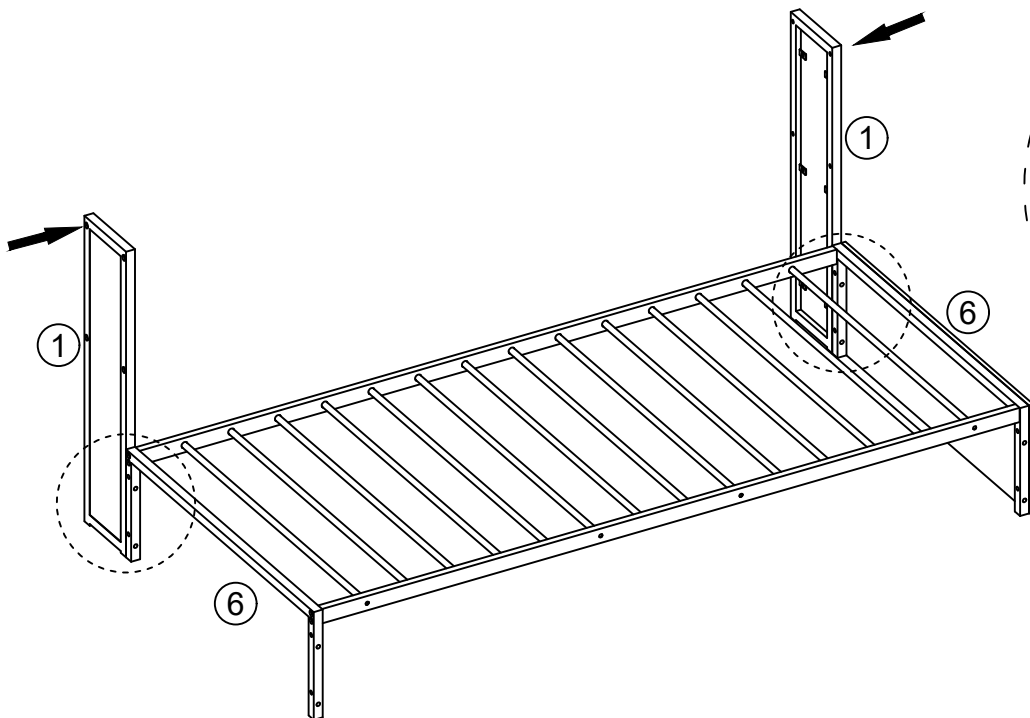



M8*40mm

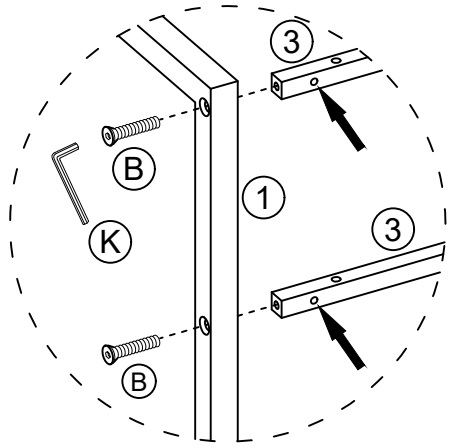

M8*45mm

40

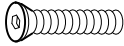

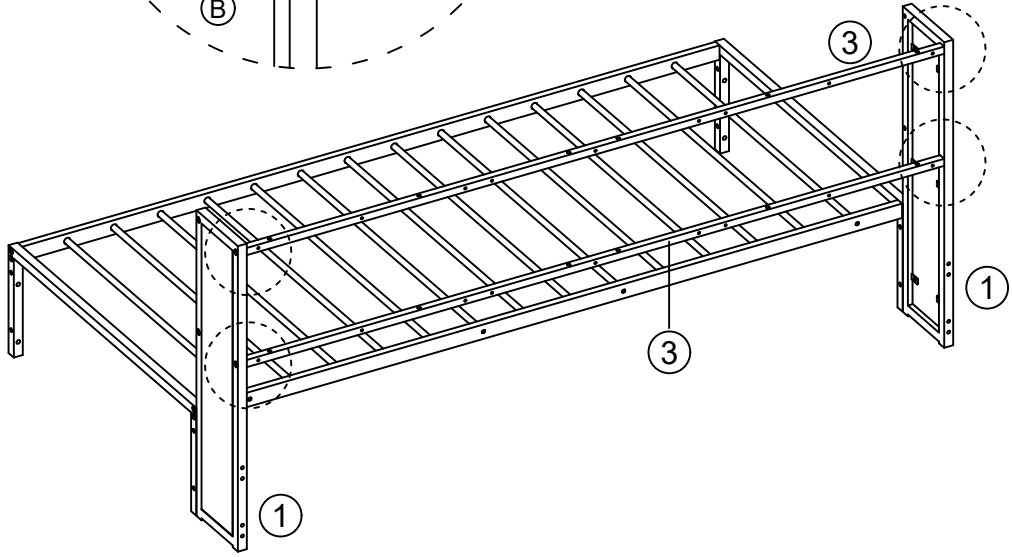

| | |
|---|--|
|  M8*45mm |  M5 |
| (B) × 4PCS | (K) × 1PC |

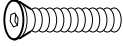
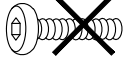

| |
|---|
|  M8*45mm |
|  M8*40mm |

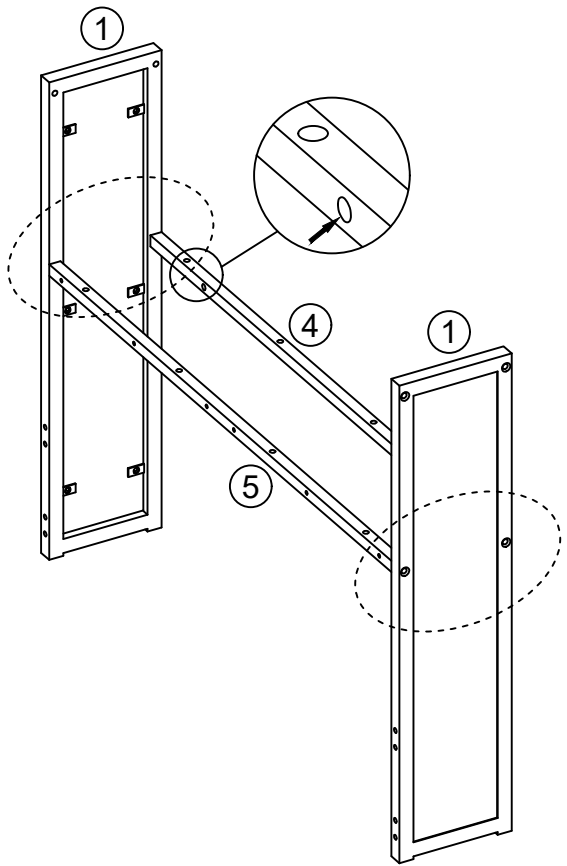
41

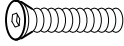

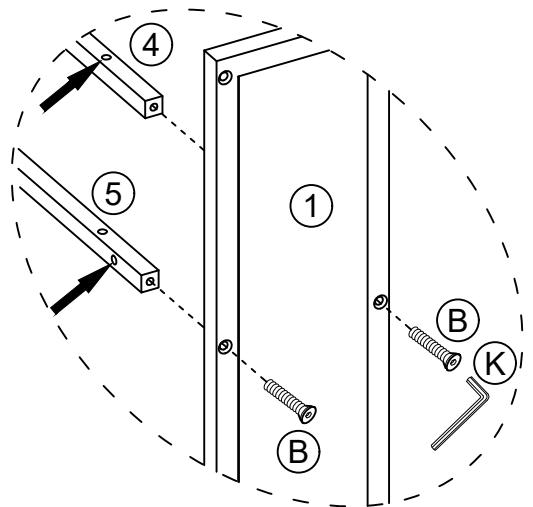

| | |
|--|---|
|  M8*45mm |  M5 |
| (B) × 4PCS | (K) × 1PC |

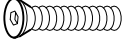
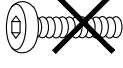

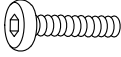

| |
|--|
|  M8*45mm |
|  M8*40mm |

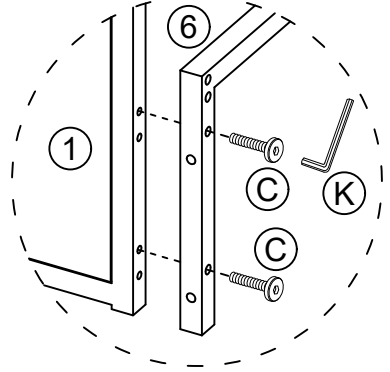
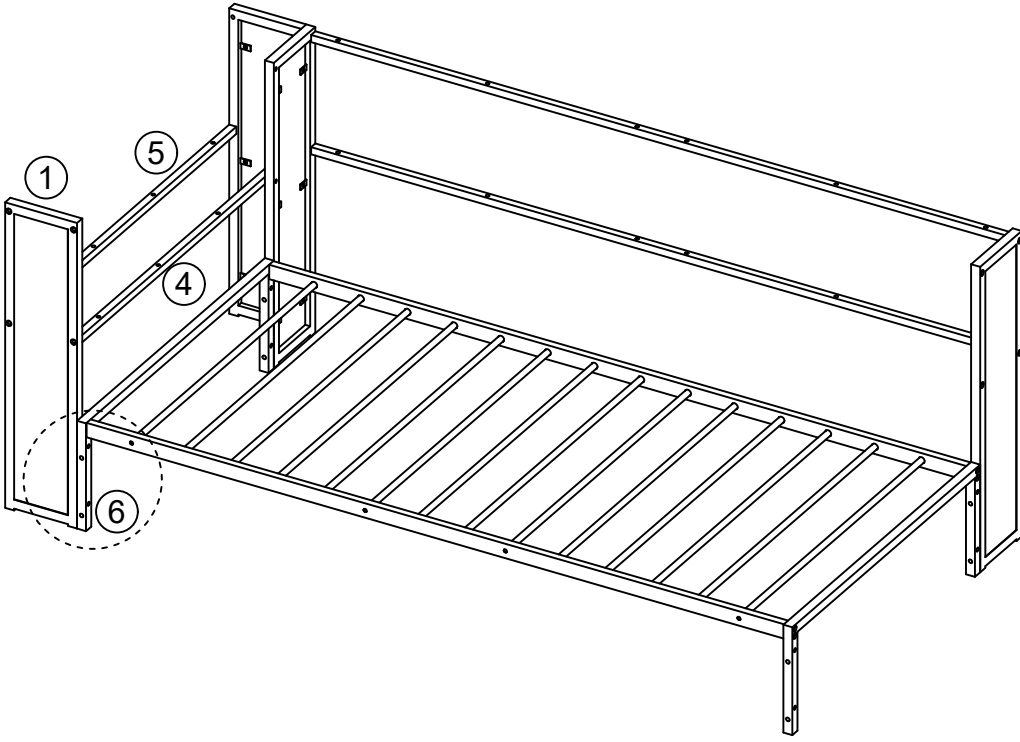

42

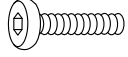
| | |
|--|--|
|  |  |
| M8*40mm | M5 |
| (C) × 2PCS | (K) × 1PC |

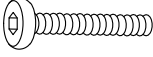

| |
|---|
|  |
| M8*40mm |
|  |
| M8*45mm |

43

| | |
|---|---|
|  |  |
| M8*60mm | M5 |
| (A) × 1PC | (K) × 1PC |

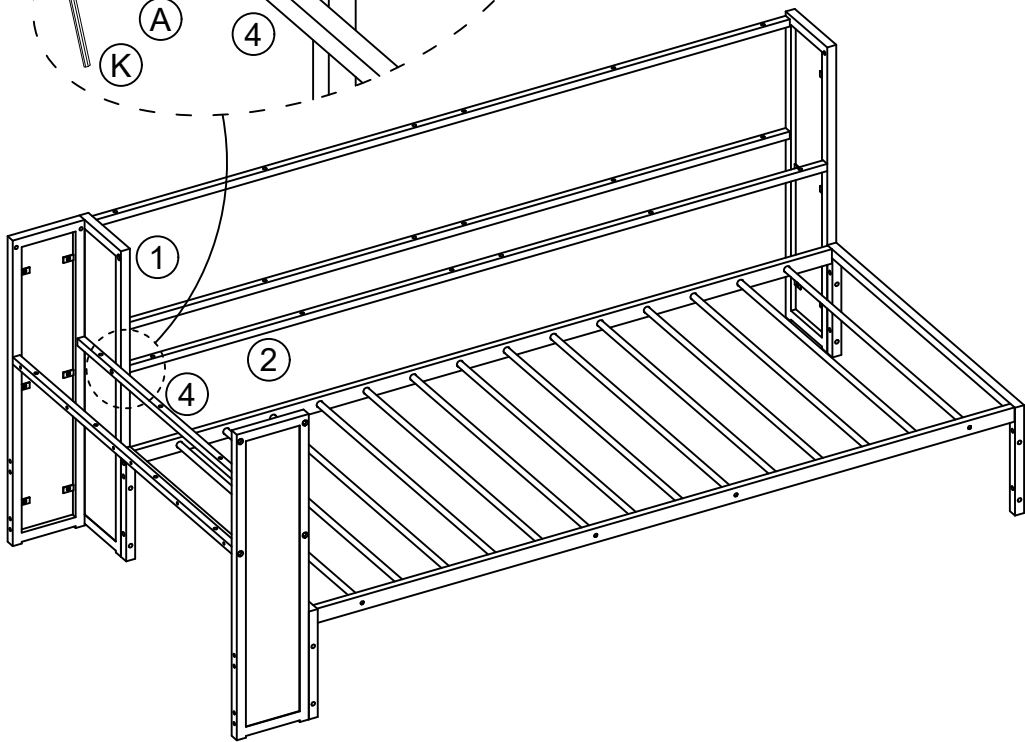
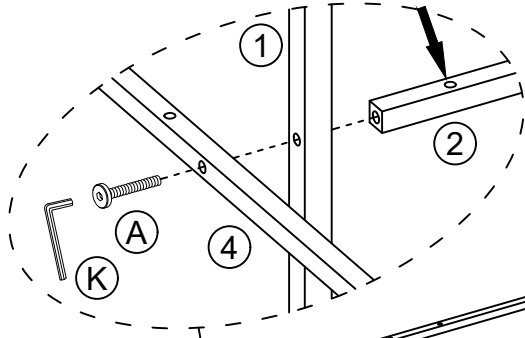

44

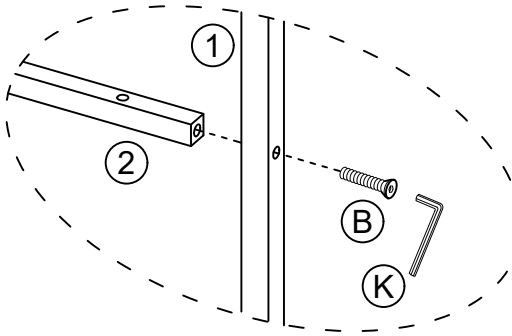

M8*45mm

(B) × 1PC



M5

(K) × 1PC

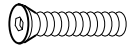
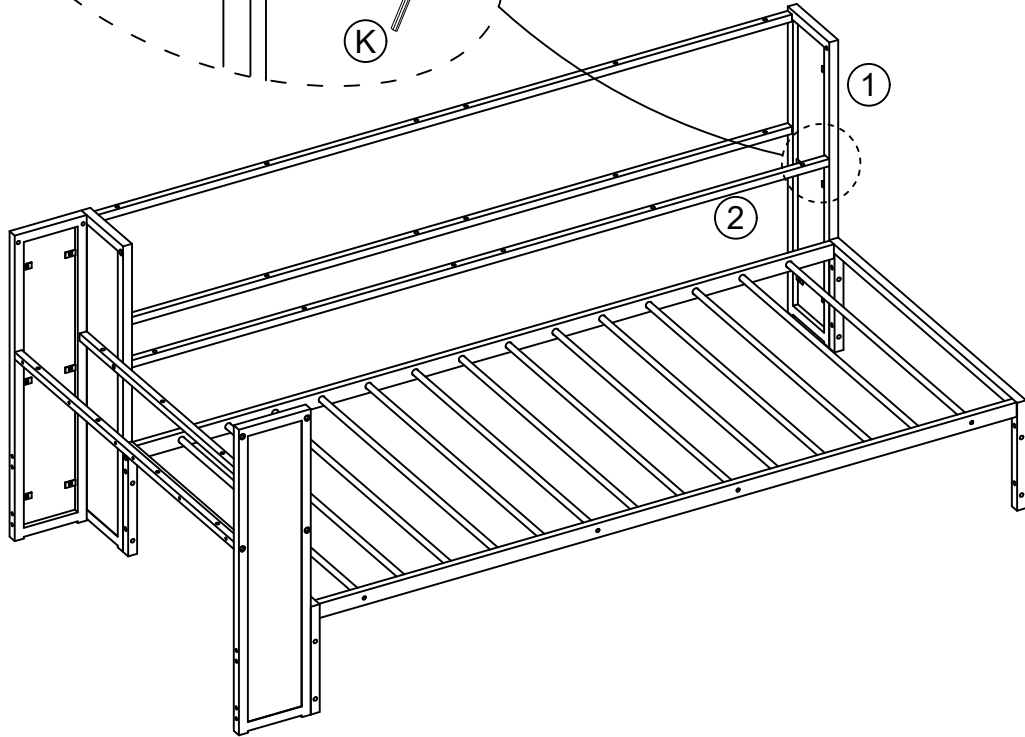

M8*45mm

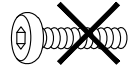

M8*40mm

45

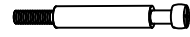

6*35mm

(H) × 4PCS

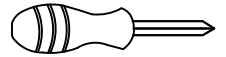

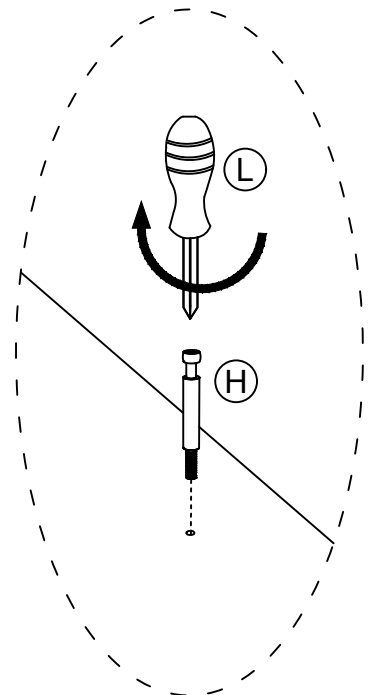
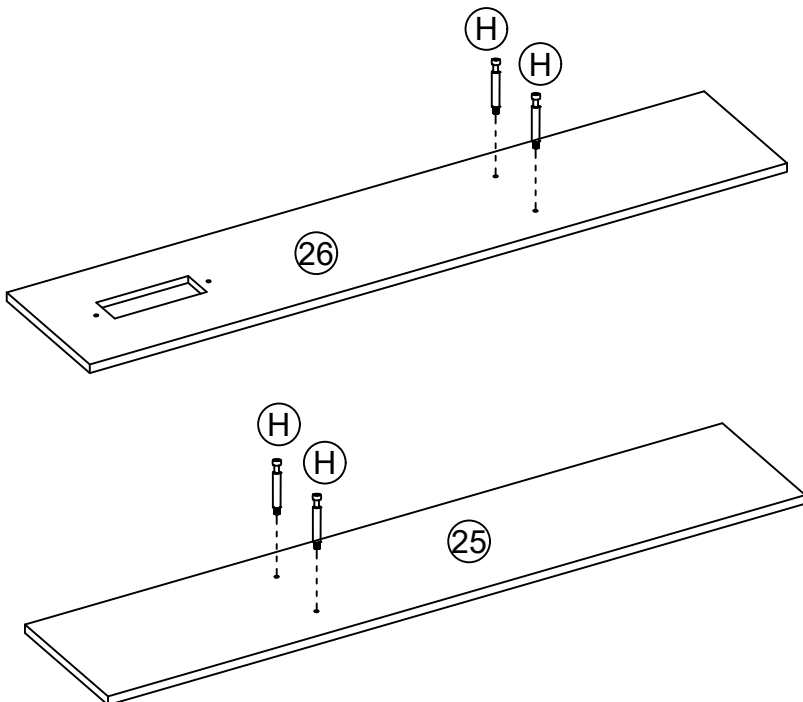

(L) × 1PC

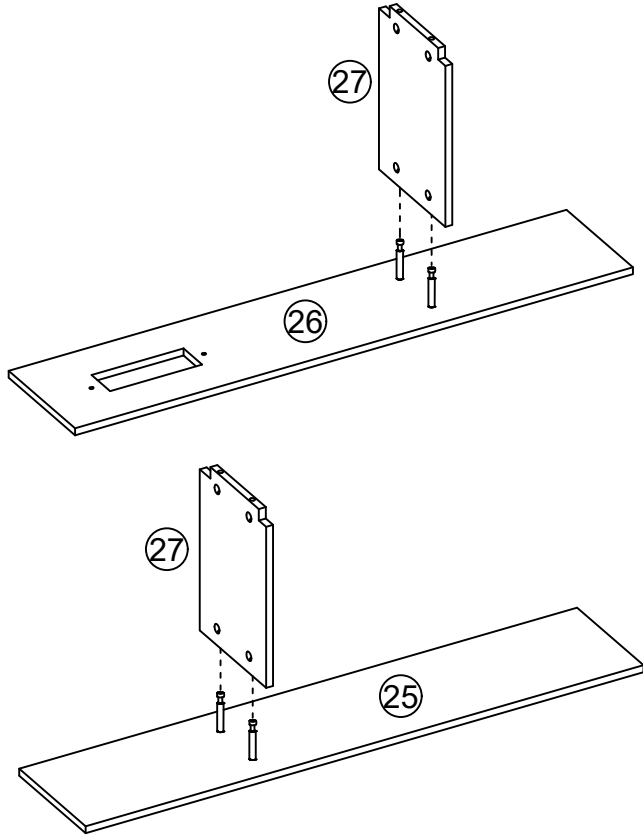

46



| | |
|---|---|
|  Ø15×9.5mm |  |
| (I) × 4PCS | (L) × 1PC |

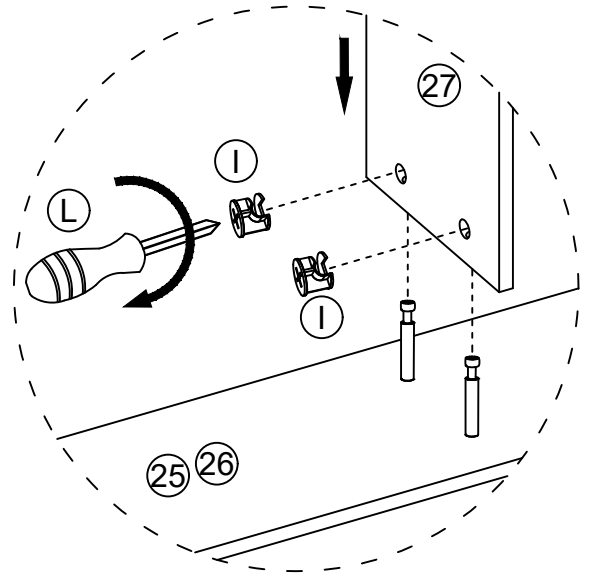

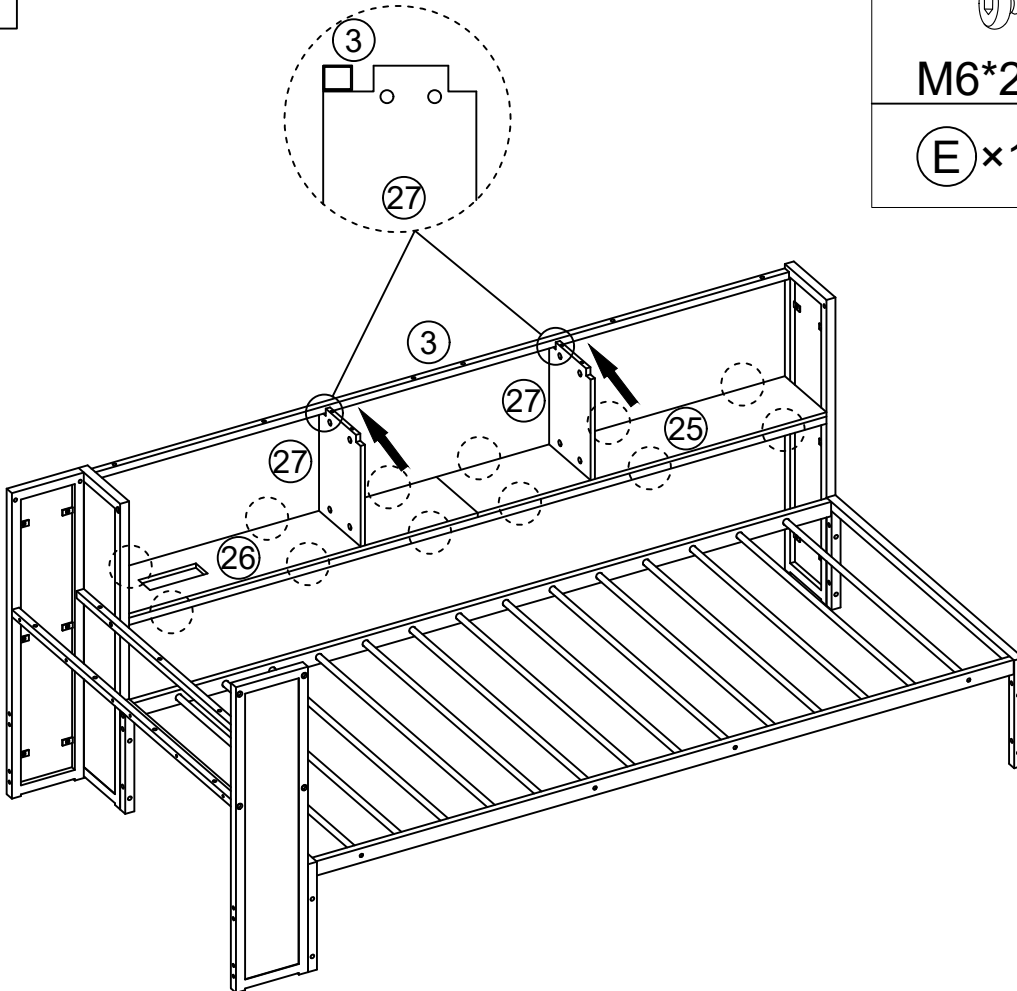

47

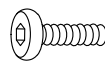
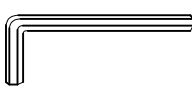

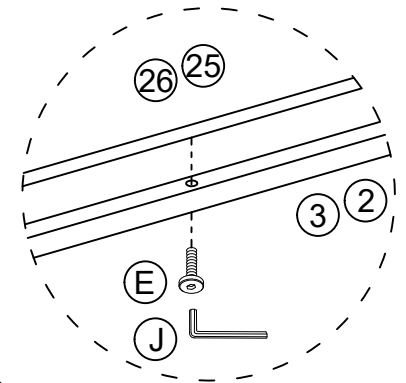
| | |
|--|---|
|  M6*28mm |  M4 |
| (E) × 12PCS | (J) × 1PC |

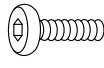
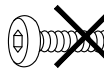

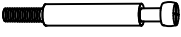
| |
|--|
|  M6*28mm |
|  M6*35mm |

| | | |
|---|--|---|
|  |  |  |
| 6*35mm | Ø15*9.5mm | |
| (H)×2PCS | (I)×2PCS | (L)×1PC |

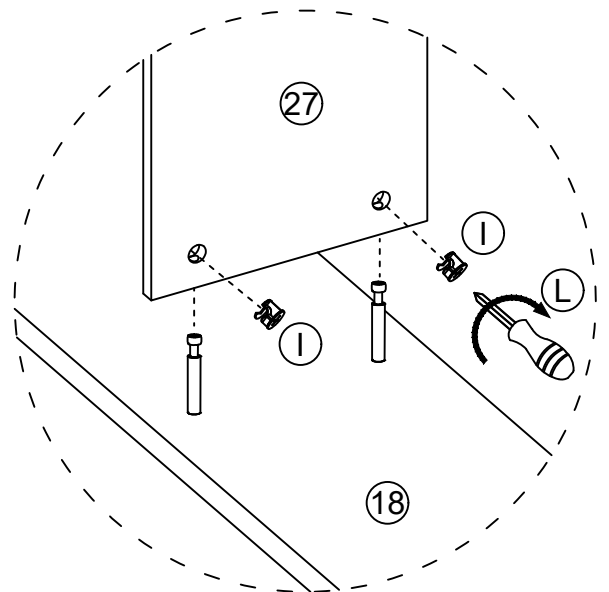
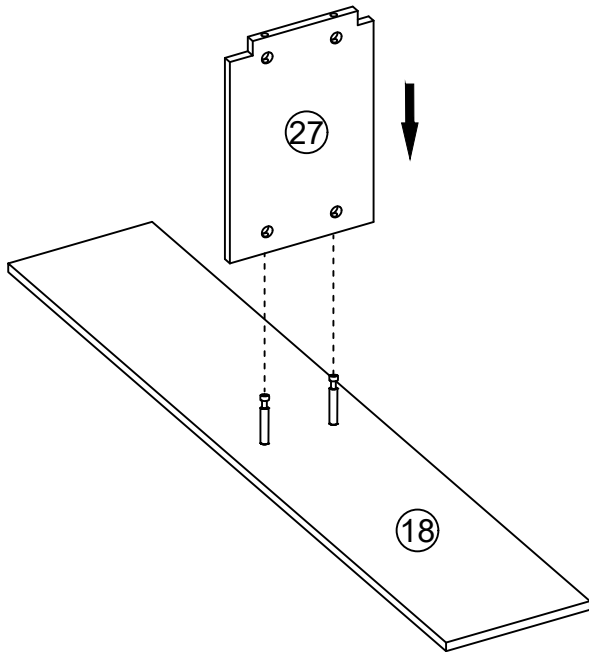
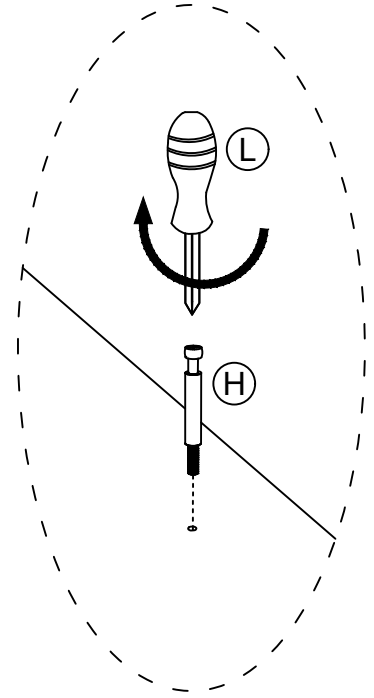
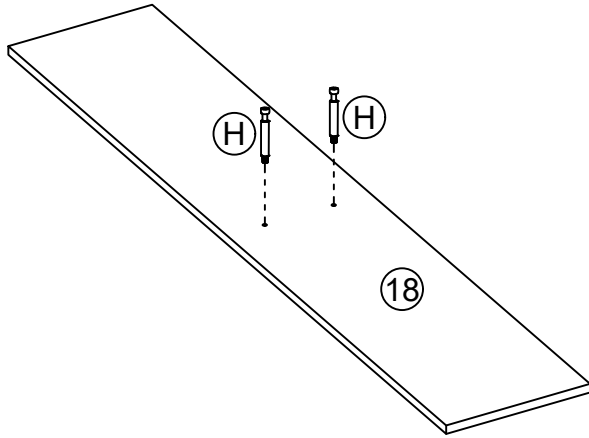

49

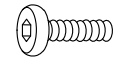

M6*28mm

(E) × 8PCS

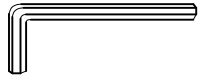

M4

(J) × 1PC

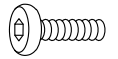
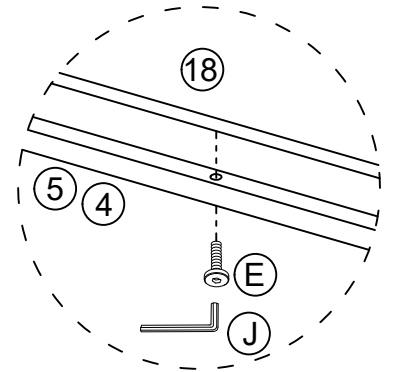
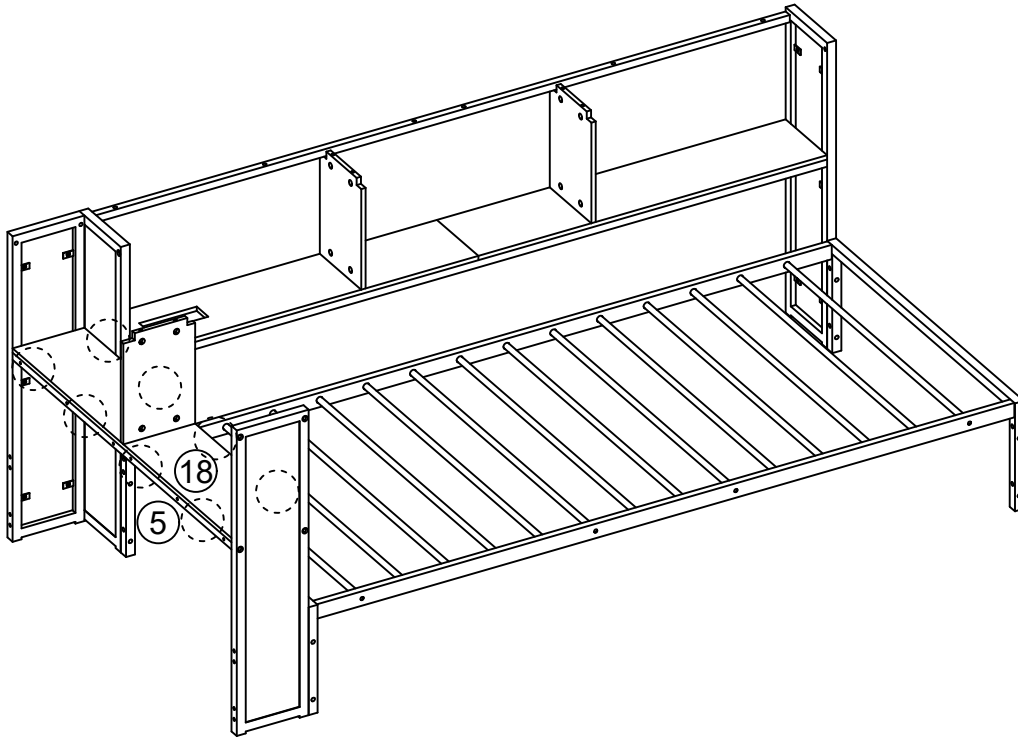

M6*28mm

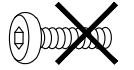

M6*35mm

50

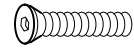

M8*45mm

(B) × 4PCS



M5

(K) × 1PC

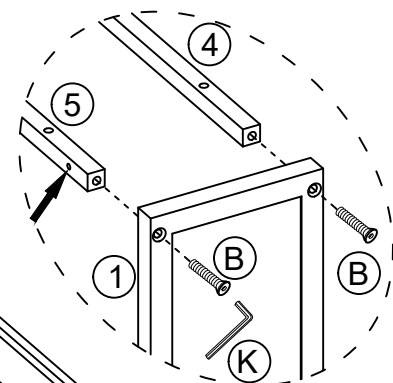
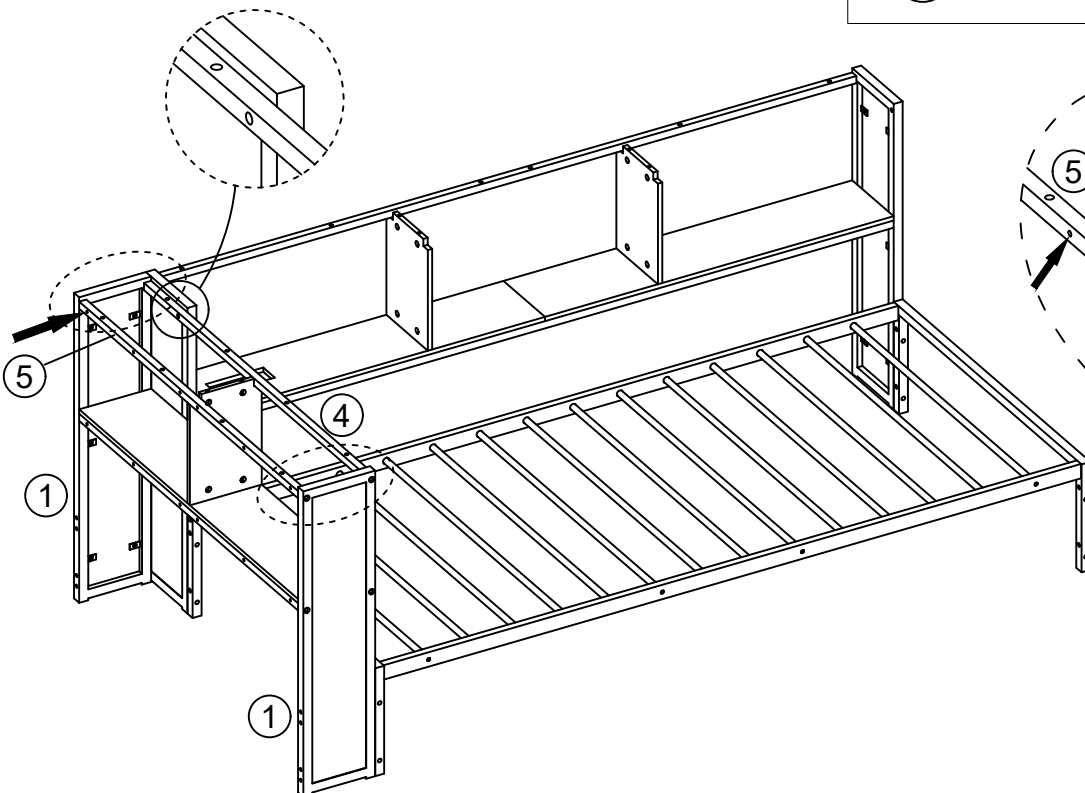

M8*45mm

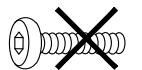

M8*40mm

51

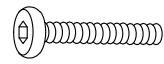
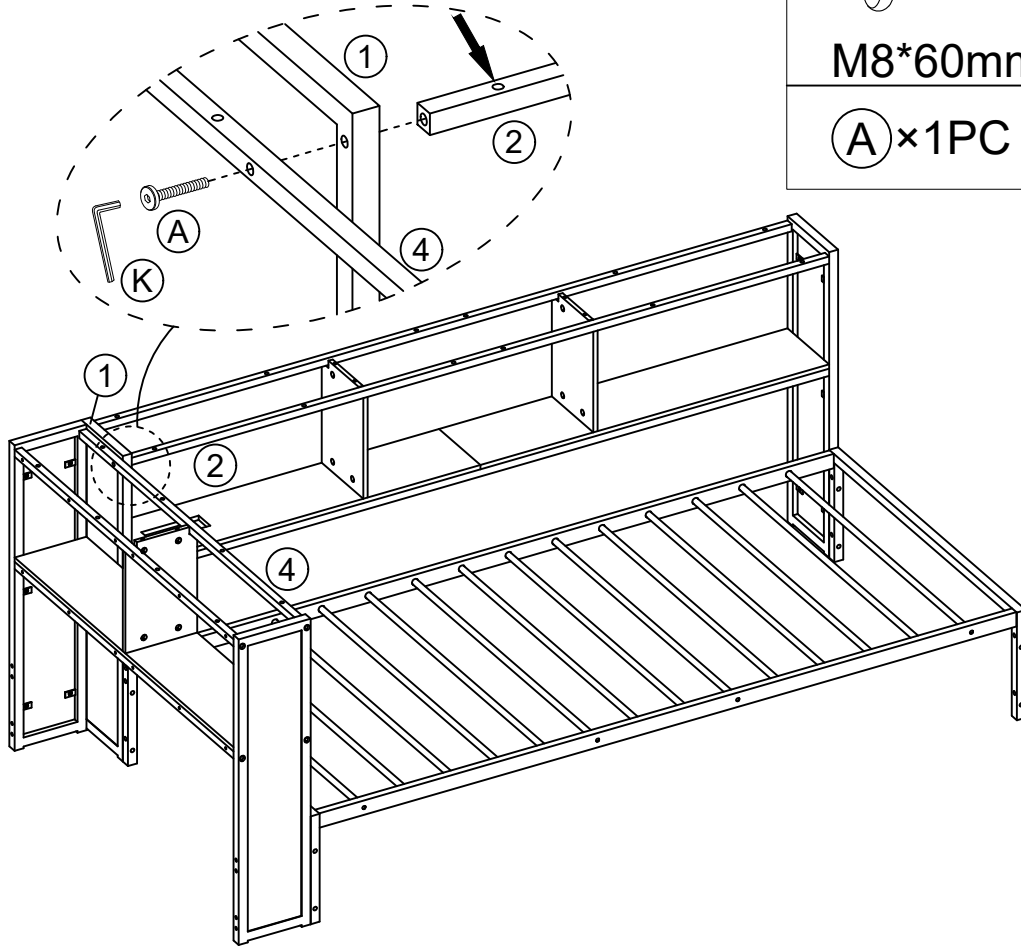

M8*60mm

(A) × 1PC

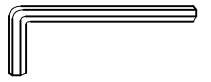

M5

(K) × 1PC

52

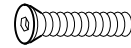
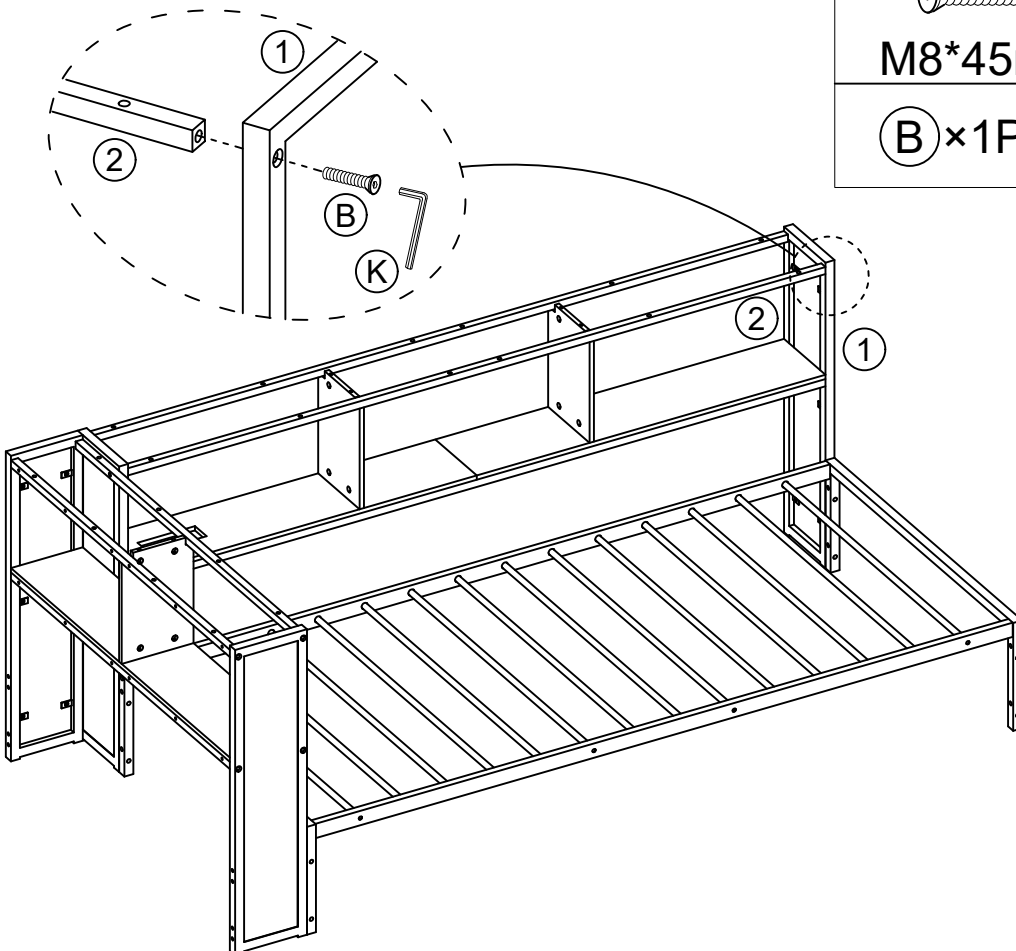

M8*45mm

(B) × 1PC



M5

(K) × 1PC

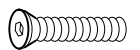

M8*45mm

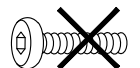

M8*40mm

53

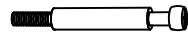

6*35mm

(H) x 6PCS

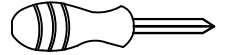

(L) x 1PC

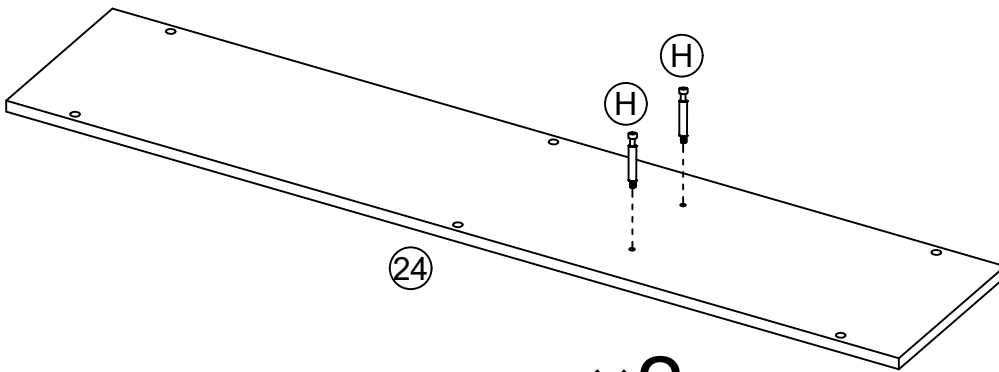
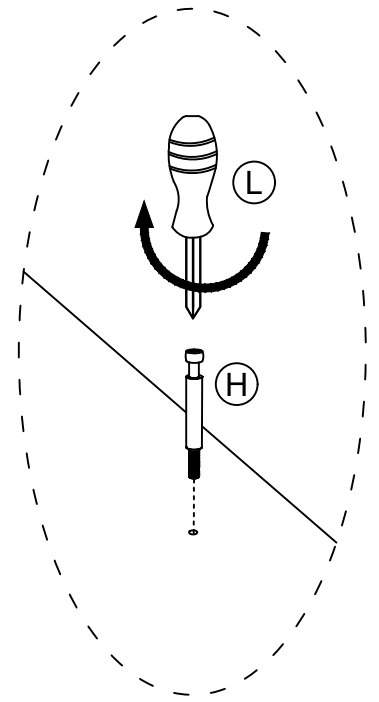
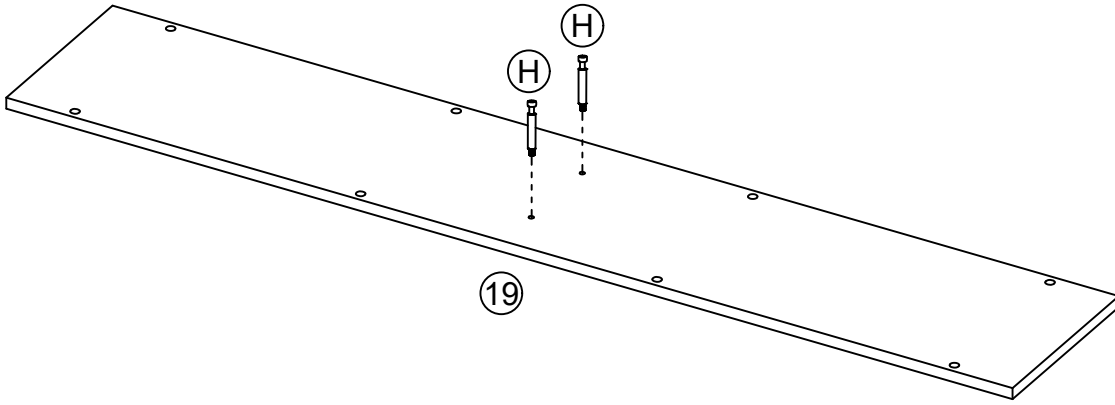

x2

54

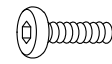
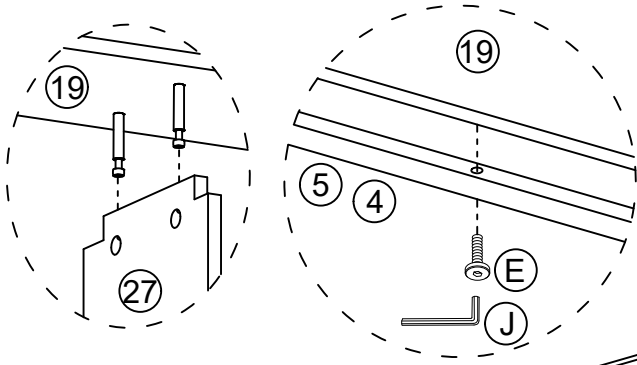

M6*28mm

(E) × 8PCS

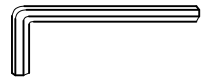

M4

(J) × 1PC

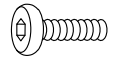
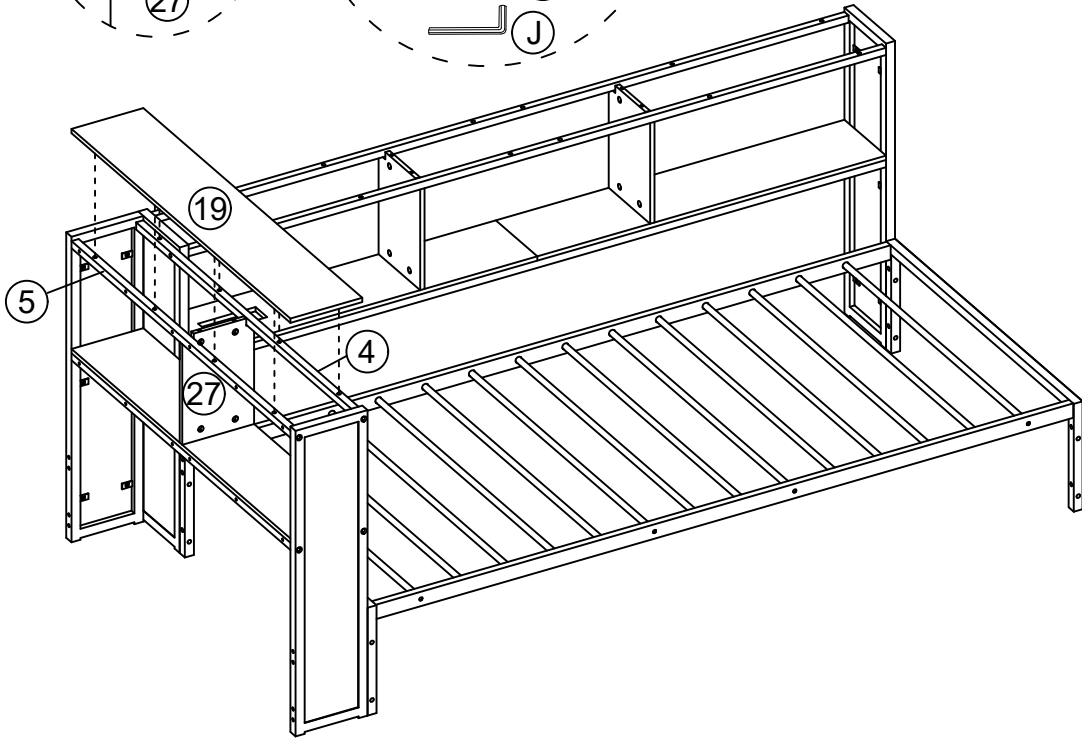

M6*28mm

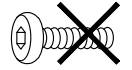

M6*35mm

55

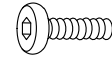
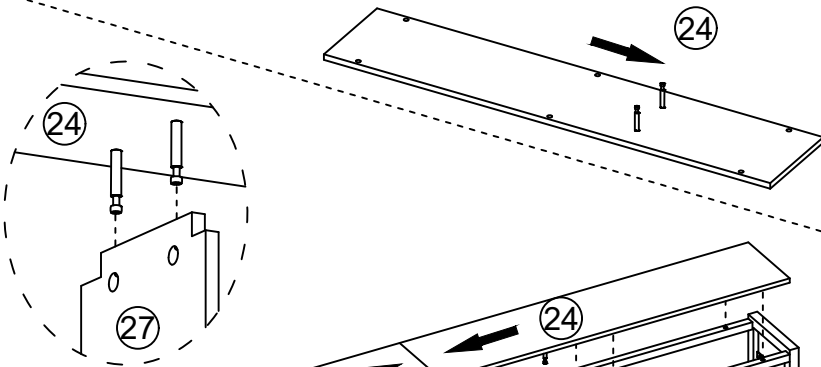

M6*28mm

(E) × 12PCS



M4

(J) × 1PC

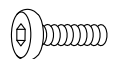
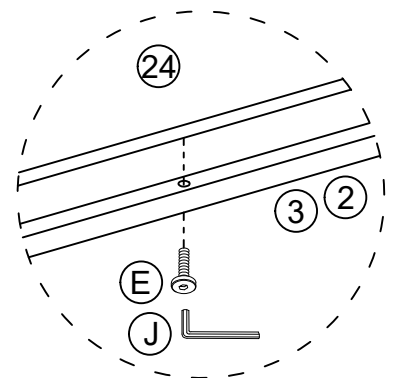
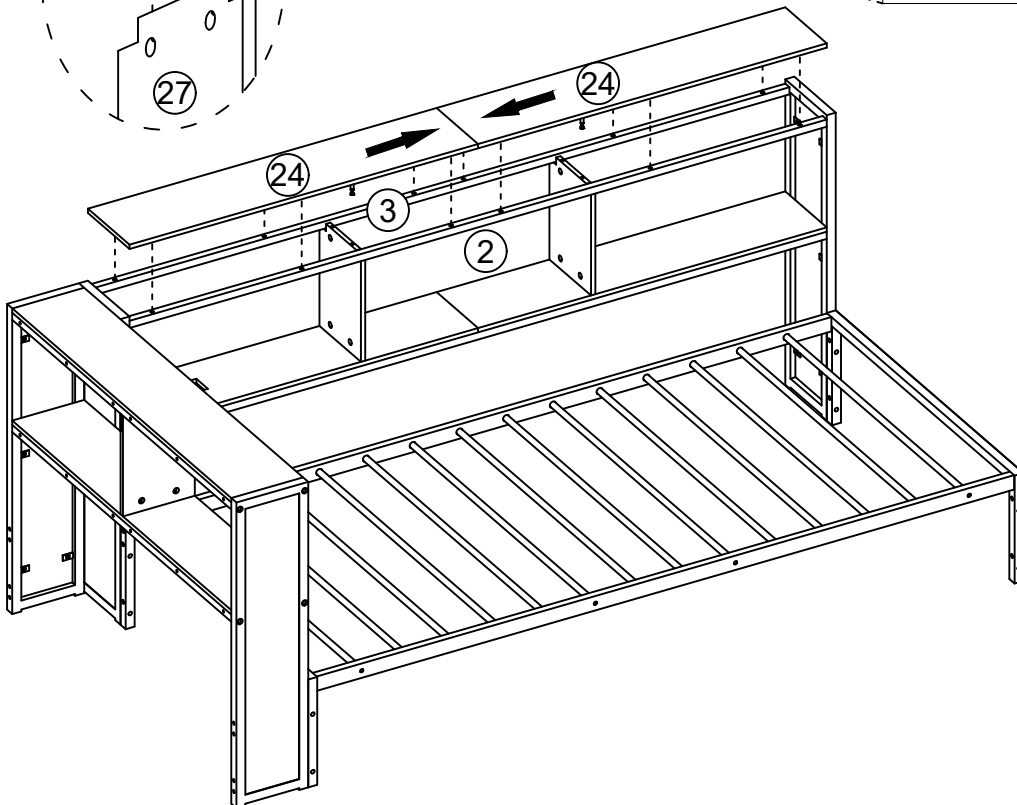

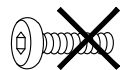

M6*28mm

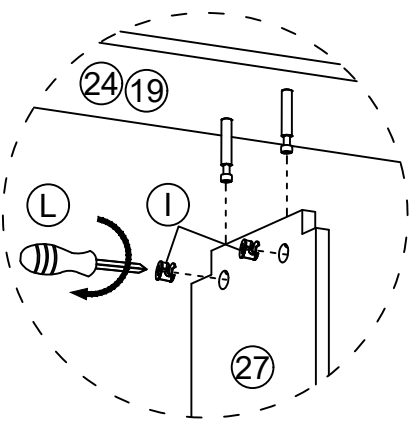

M6*35mm

56



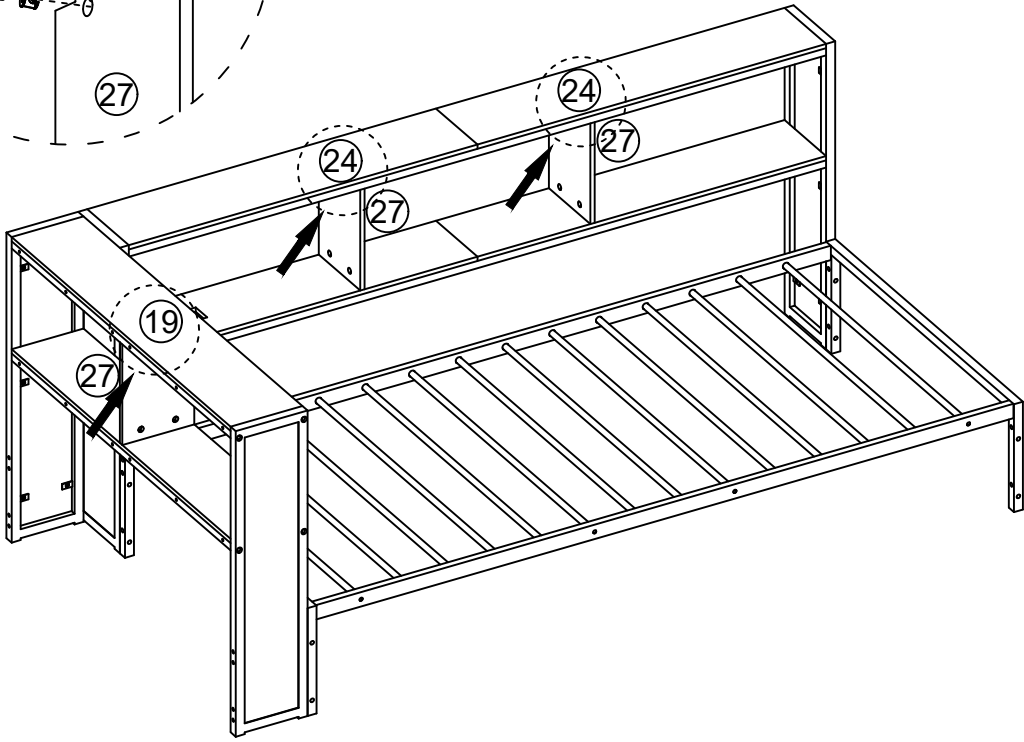

| | |
|--|---|
|  |  |
| Ø15×9.5mm | |
| (I)×6PCS | (L)×1PC |

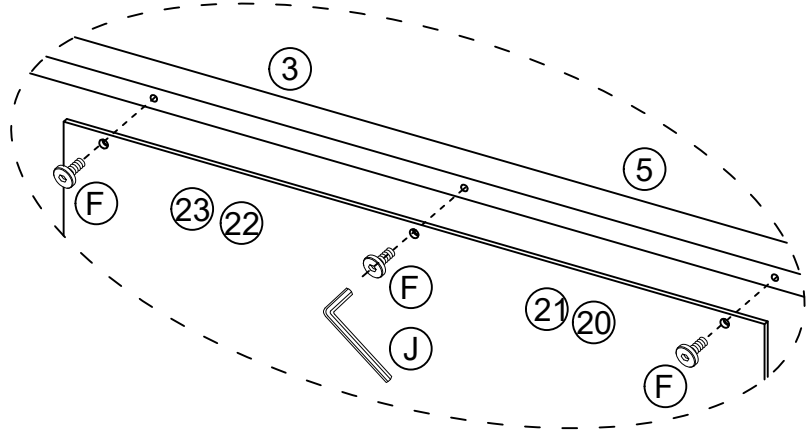

57



| | |
|---|---|
|  |  |
| M6*15mm | M4 |
| (F)×30PCS | (J)×1PC |

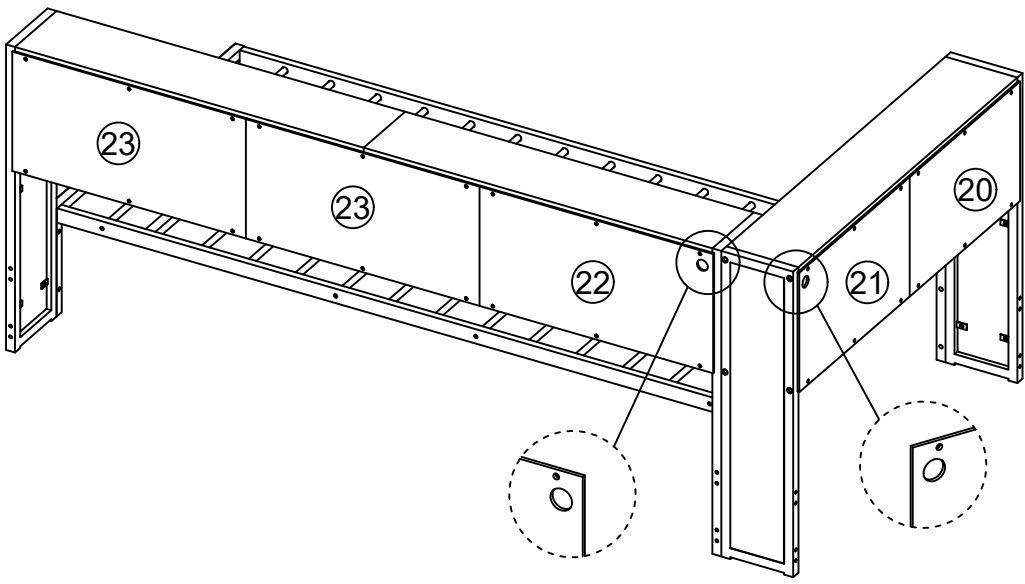

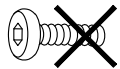
| |
|---|
|  |
| M6*15mm |
|  |
| M6*28mm |

58

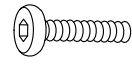

M6*35mm

(D) × 4PCS



M4

(J) × 1PC

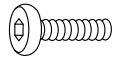
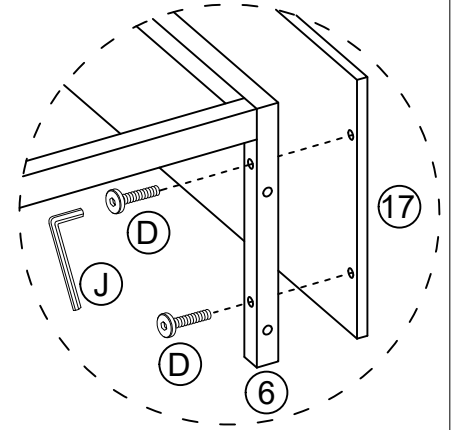
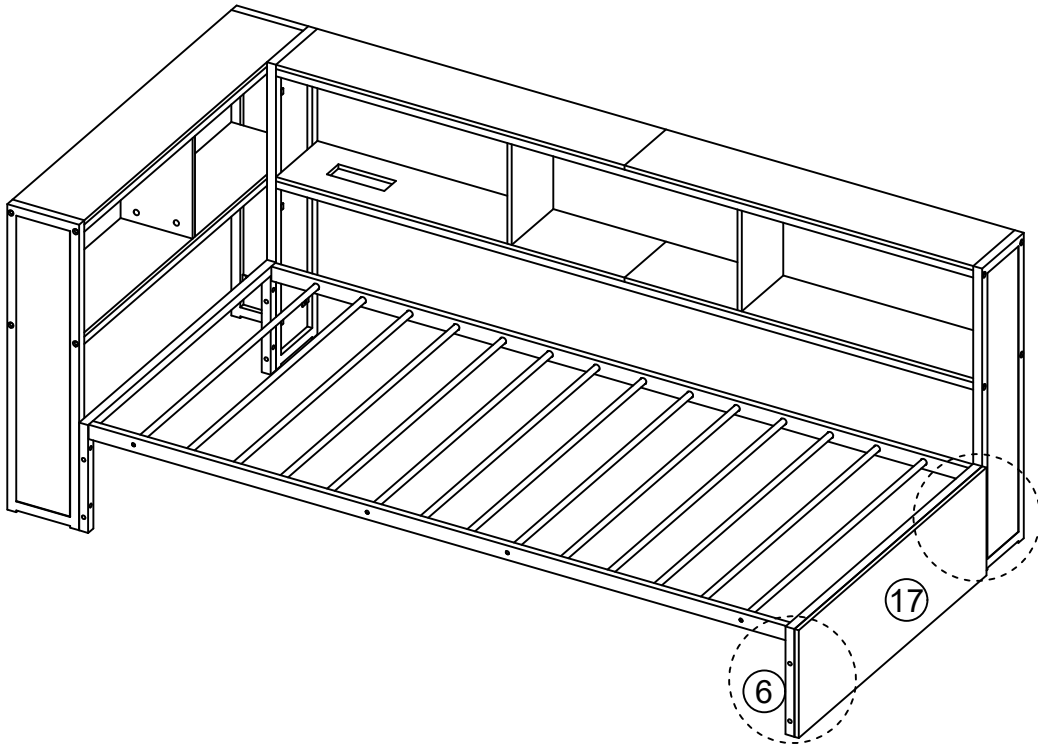

M6*35mm

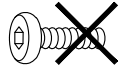

M6*28mm

59



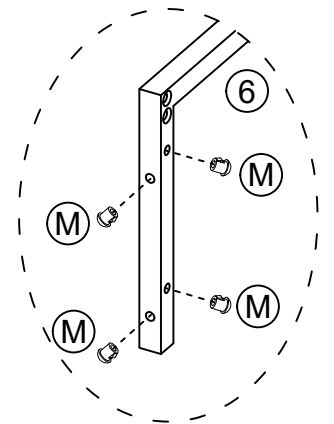
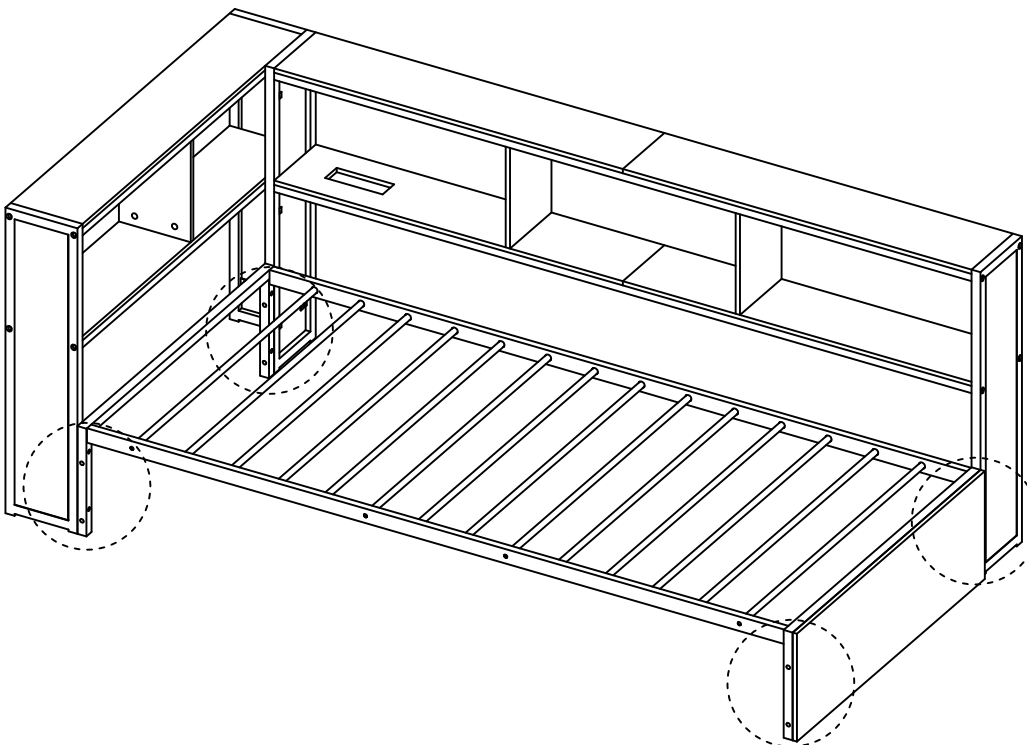

(M) × 12PCS



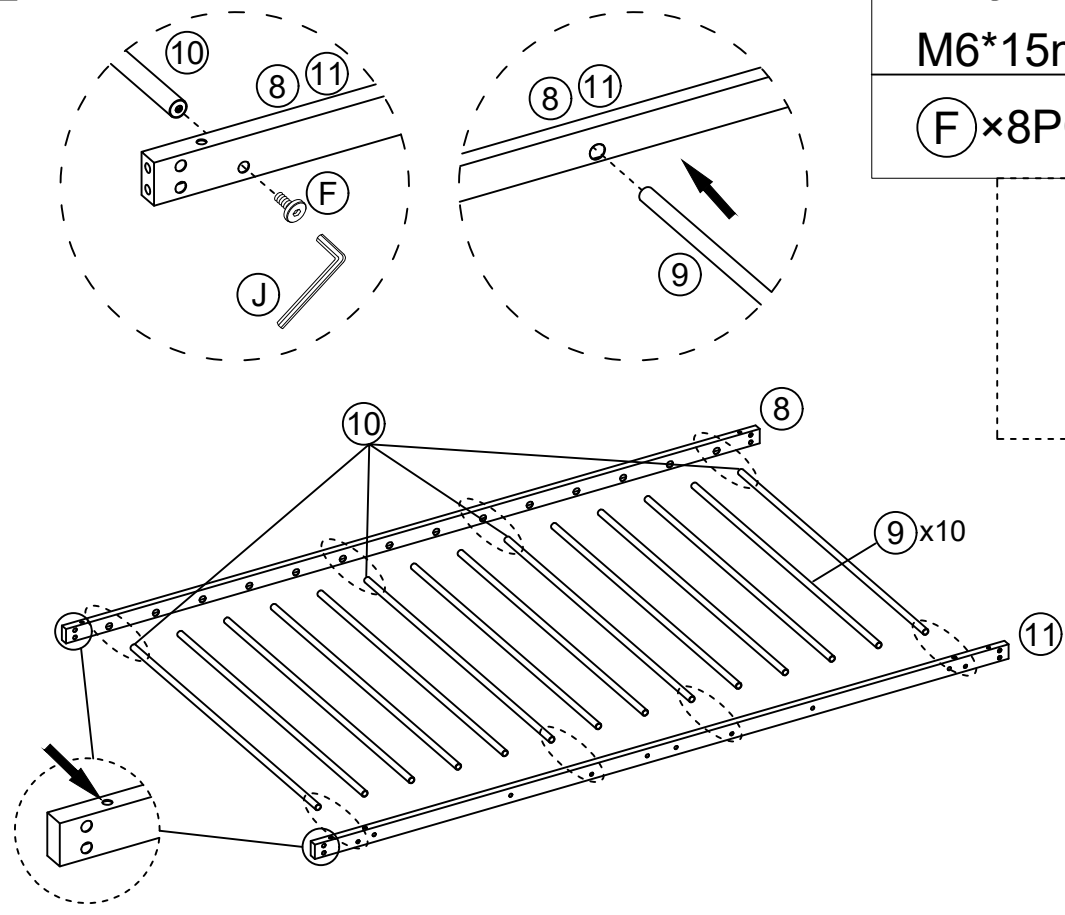

60



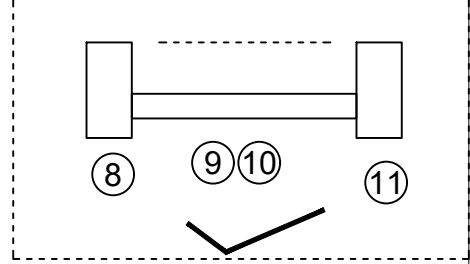

| | |
|--|--|
|  |  |
| M6*15mm | M4 |
| (F) × 8PCS | (J) × 1PC |



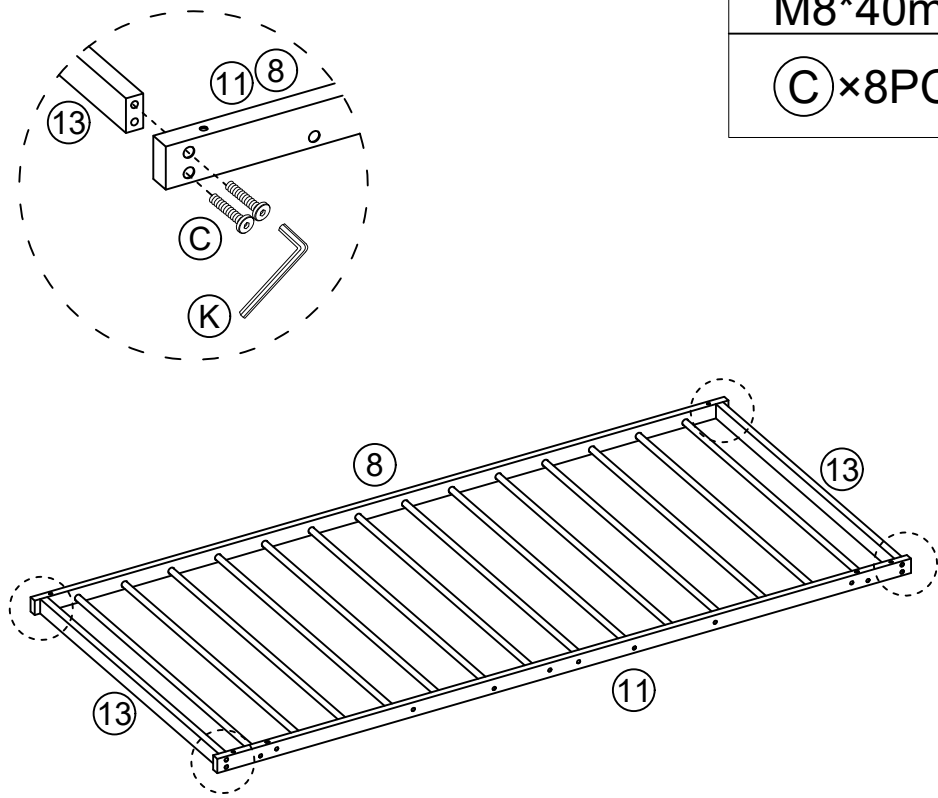

| |
|---|
|  |
| M6*15mm |
|  |
| M6*28mm |

61



| | |
|---|---|
|  |  |
| M8*40mm | M5 |
| (C) × 8PCS | (K) × 1PC |

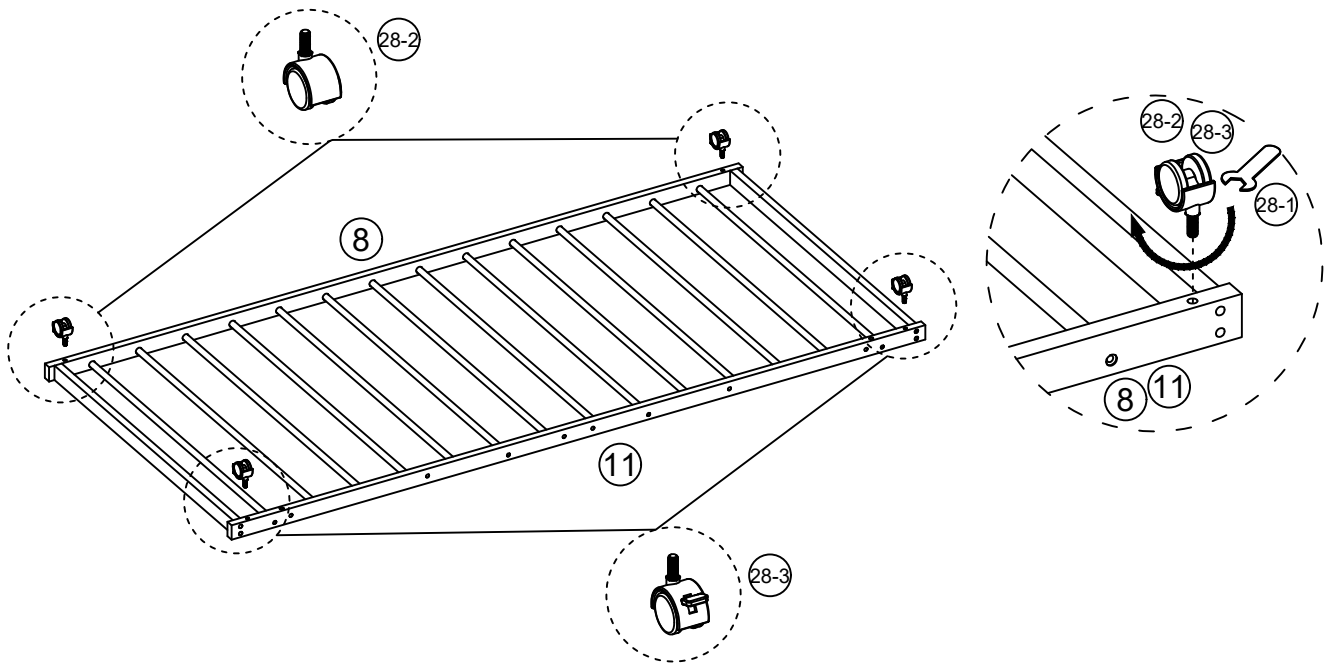

| |
|--|
|  |
| M8*40mm |
|  |
| M8*45mm |

62

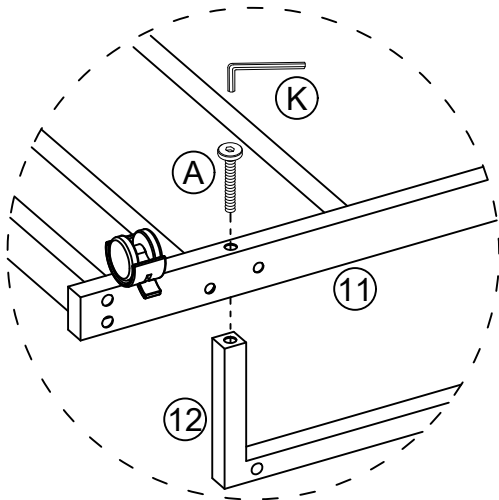

63

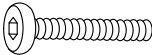

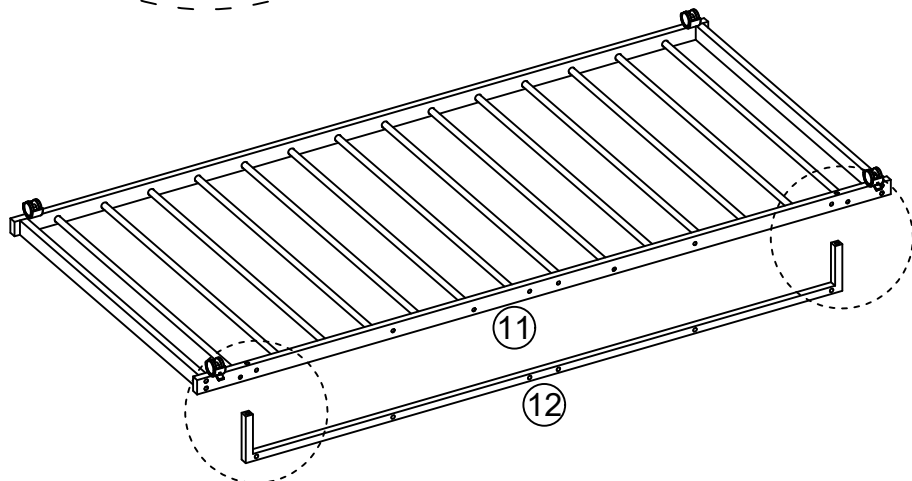

| | |
|---|---|
|  |  |
| M8*60mm | M5 |
| (A) x 2PC | (K) x 1PC |

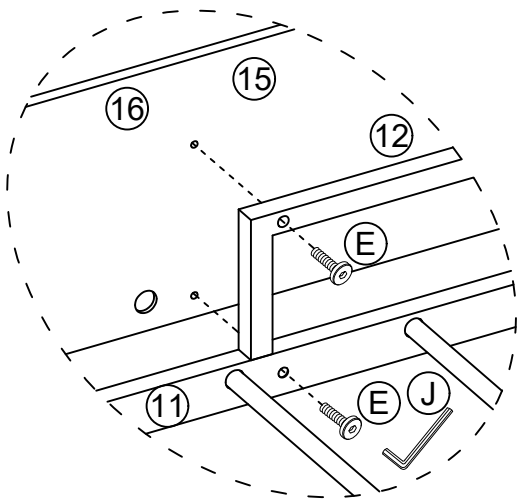

64



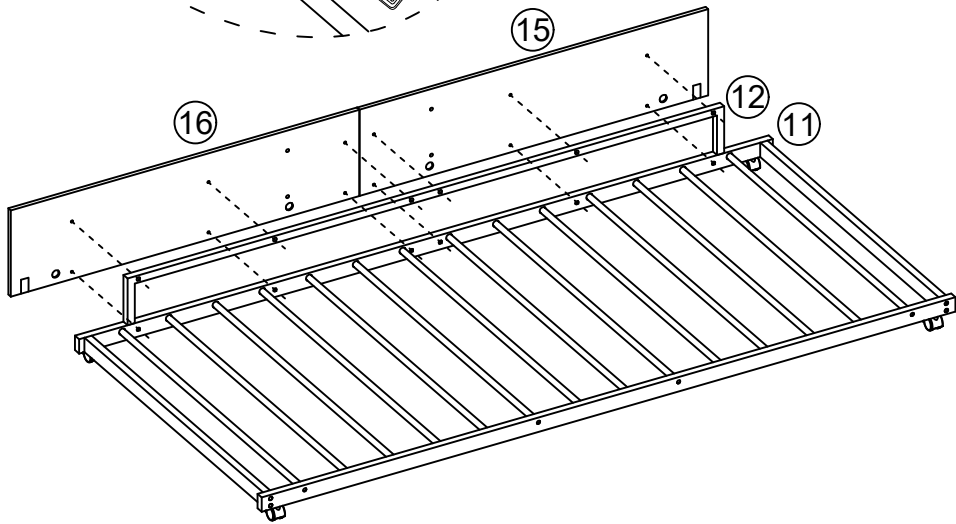

| | |
|--|--|
|  |  |
| M6*28mm | M4 |
| (E) × 12PCS | (J) × 1PC |

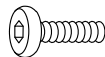
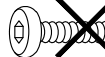

| |
|---|
|  |
| M6*28mm |
|  |
| M6*35mm |

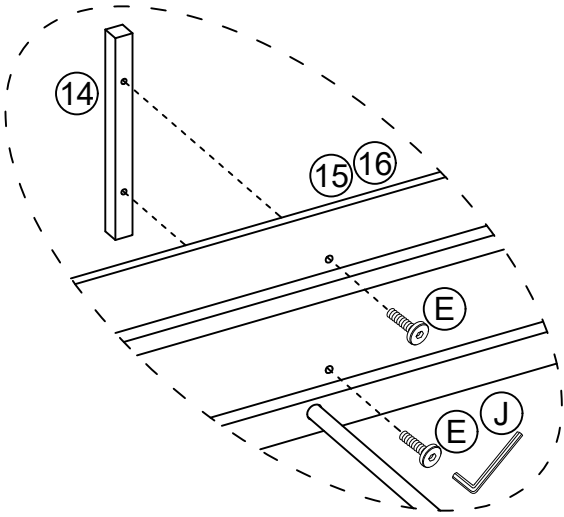
65



| | |
|---|---|
|  |  |
| M6*28mm | M4 |
| (E) × 4PCS | (J) × 1PC |

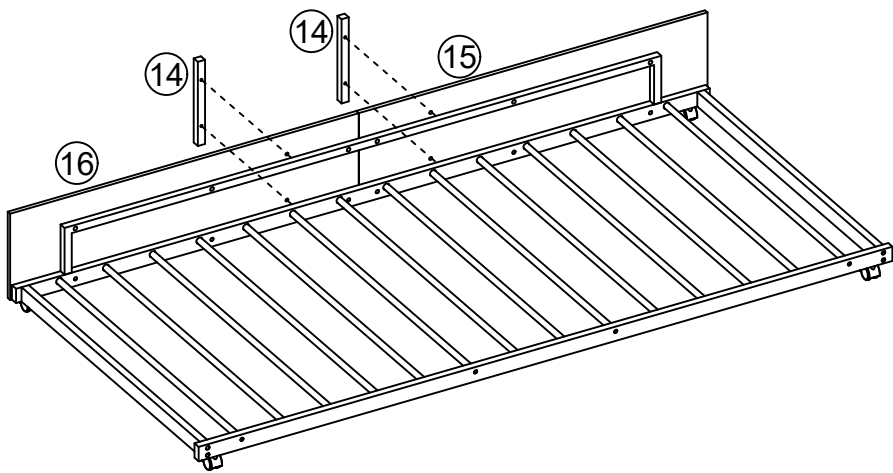

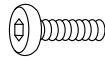
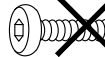
| |
|--|
|  |
| M6*28mm |
|  |
| M6*35mm |

66

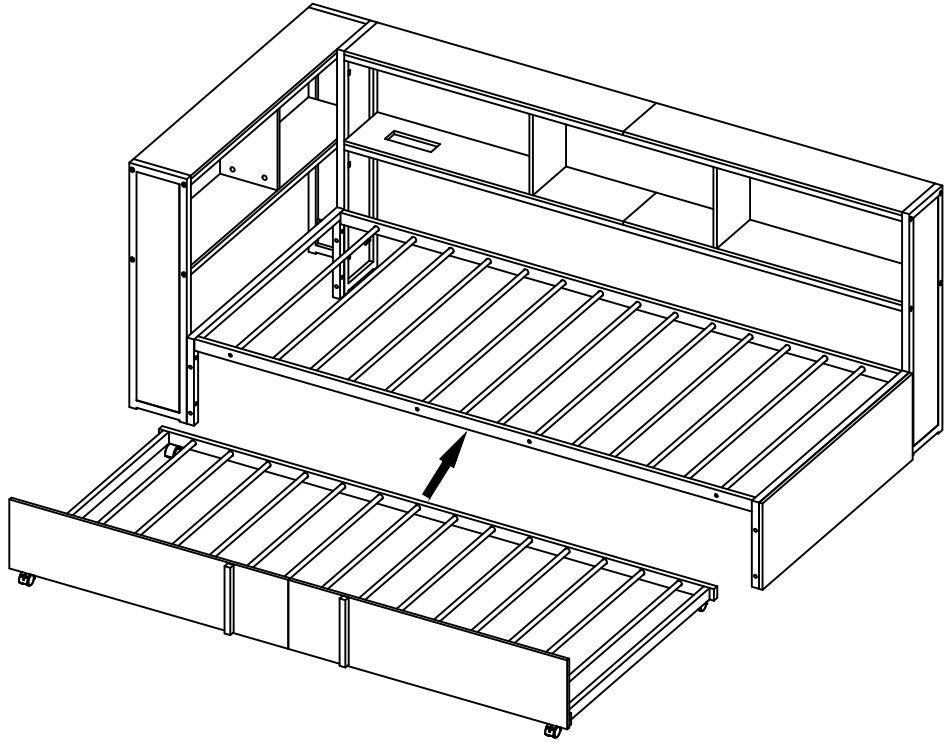

67



M3*12mm

(G) × 2PCS

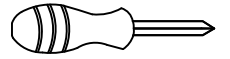

(L) × 1PC

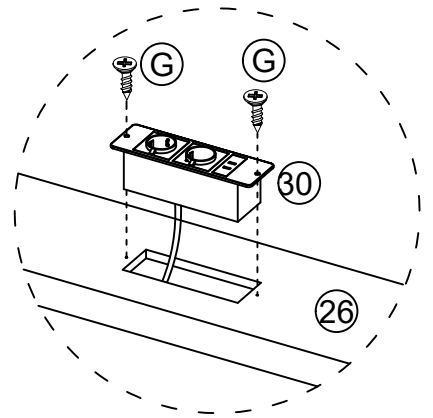
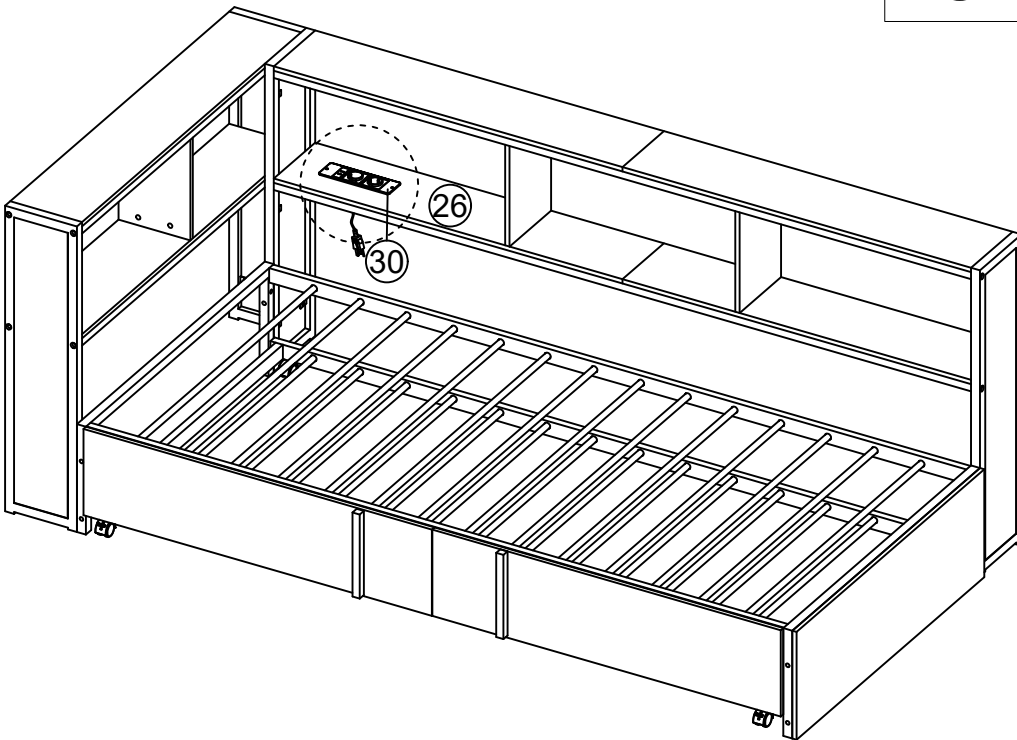

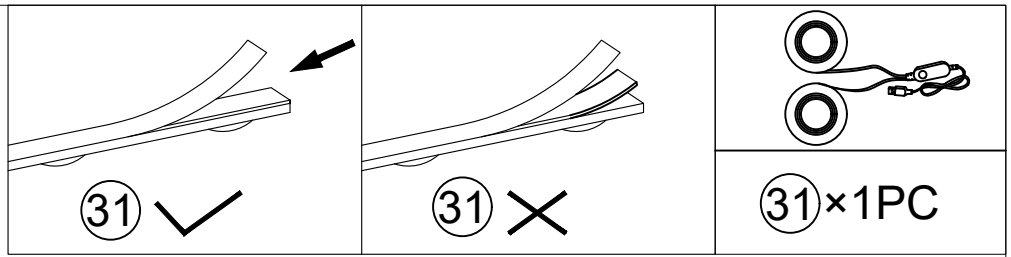

The light strip has long and short.

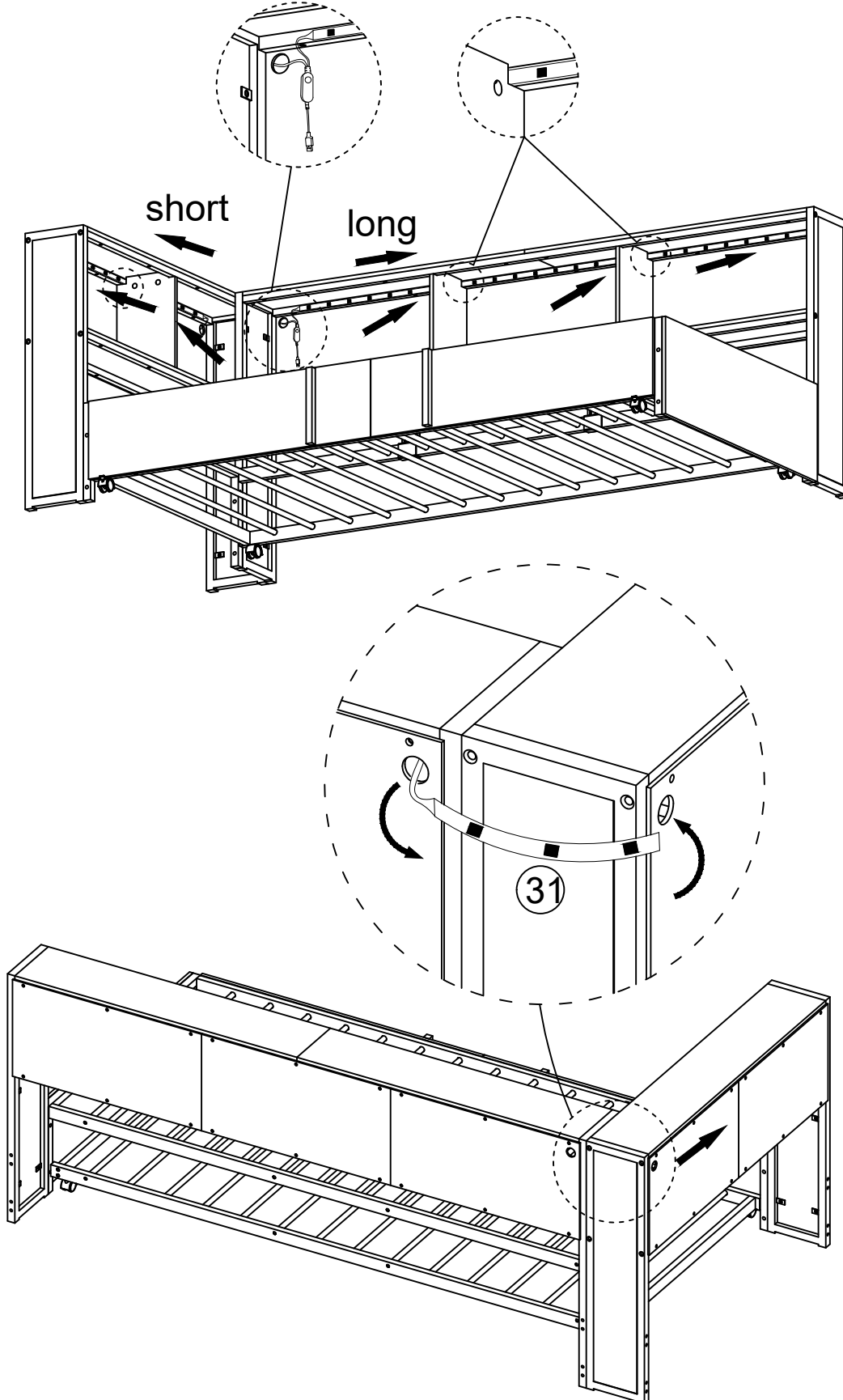

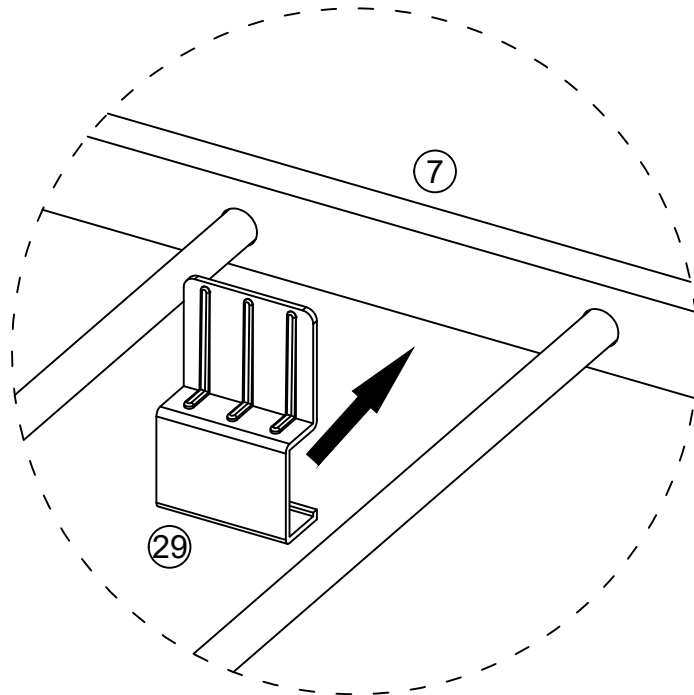
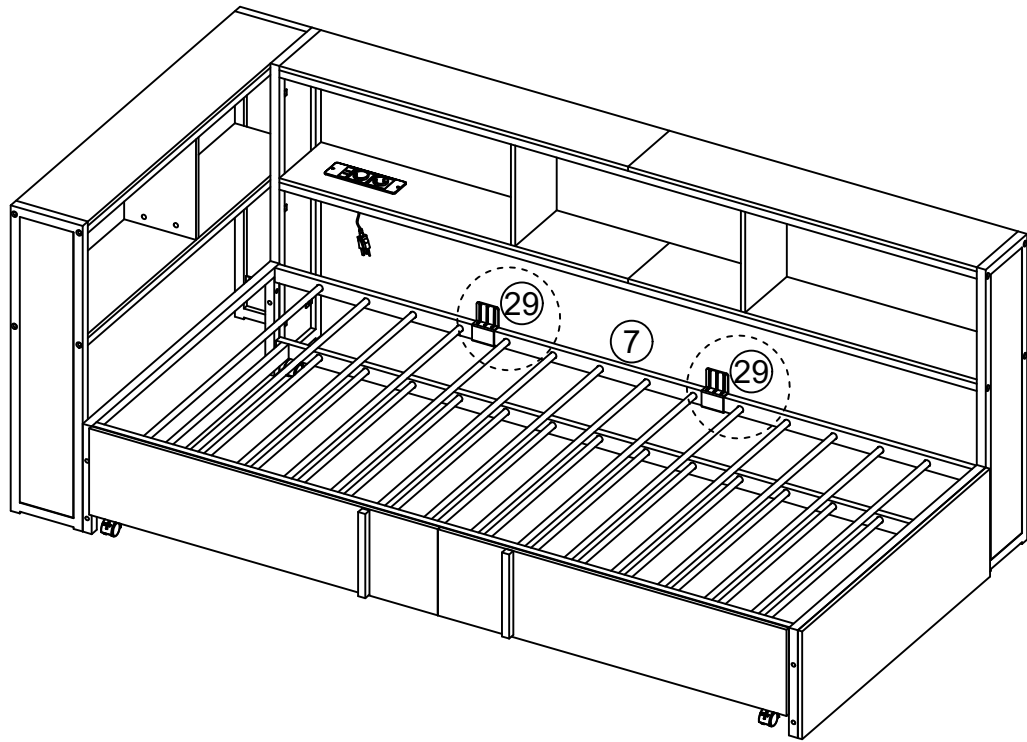



True Safety Testing

Certificate Of Compliance

Certificate No. : TST20230830130-1SC
Applicant : Shenzhen Yubo Star Intelligent Technology Co., Ltd
A604, No. 271, West District, Zhangge Village, Zhangge Community, Fucheng Street, Longhua District, Shenzhen
Manufacturer : Shenzhen Yubo Star Intelligent Technology Co., Ltd
502, Floor 5, No. 4, Zhanqian West Road, Mulun Village, Changping Town, Dongguan City
Product Name : USB TV background light bar
Trade Mark : N/A
Main Model : YBXZN001
Rating : 5V 3.5A 17.5W
Series Models : YBX-ZN-001, YBX-ZN-002, YBX-ZN-003, YBX-ZN-004, YBX-ZN-005, YBX-ZN-006, YBX-ZN-007, YBX-ZN-008, YBX-ZN-009, YBX-ZN-010
Test Standard : EN IEC 60598-1:2021
EN 60598-2-20:2015
As shown in the Test Report No. : TST20230830130-1SR

The EUT described above has been tested by us with the listed standards and found in compliance with the council LVD directive 2014/35/EU. It is possible to use CE marking to demonstrate the compliance with this LVD Directive.

The certificate applies to the tested sample above mentioned only and shall not imply an assessment of the whole production. It is only valid in connection with the test report number. TST20230830130-1SR



Andy
Certification Manager
Date: Aug. 09, 2023

Dongguan True Safety Testing Co., Ltd.

Room 201, No.20, East of Houjie Avenue, Houjie, Dongguan, Guangdong, China

Tel: 86-0769-85088050 4001086960 E-mail:tst@tst-test.com <http://www.tst-test.com>

Shenzhen ZKT Technology Co., Ltd.
1/F, No. 101, Building B, No. 6, Tangwei Community Industrial Avenue,
Fuhai Street, Bao'an District, Shenzhen, China



Certificate of Compliance

Certificate Number: ZKT-250516L9522C

Certificate's Holder : Guangdong Zhangong Electric Technology Co., LTD
701, Building 29, zhifuyuan Industrial Zone, Xingtan town,
Shunde District, Foshan City, Guangdong Province

Manufacturer : Guangdong Zhangong Electric Technology Co., LTD
701, Building 29, zhifuyuan Industrial Zone, Xingtan town,
Shunde District, Foshan City, Guangdong Province

Trade Mark : /

Product : Furniture socket

Model(s) : ZG-JJO-B2A-2A
ZG-JJO-B2B-2A, ZG-PDU J00

Test Standard : EN 55032:2015 + A11:2020 + A1:2020
EN 55035:2017 + A11:2020
EN IEC 61000-3-2:2019 + A1:2021 + A2:2024
EN 61000-3-3:2013 + A1:2019 + A2:2021

This Attestation of Compliance is issued for electrical equipment below the voltage limits of EMC Directive 2014/30/EU. The essential requirements are fulfilled accordingly based on the technical specifications applicable at the time of issuance. It is only valid in connection with the test report. It is only valid in connection with the test report number: ZKT-250516L9522E.



This Certificate of Conformity is based on single evaluation of the submitted sample(s) of the above mentioned product. It does not imply an assessment of the whole product and relevant Directives to be observed.