

# Montageanleitung | Instructions de montage Assembly Instructions | Instrucciones de montaje

SKU NUMBER: N616P425595/N616P425596  
N616P425597

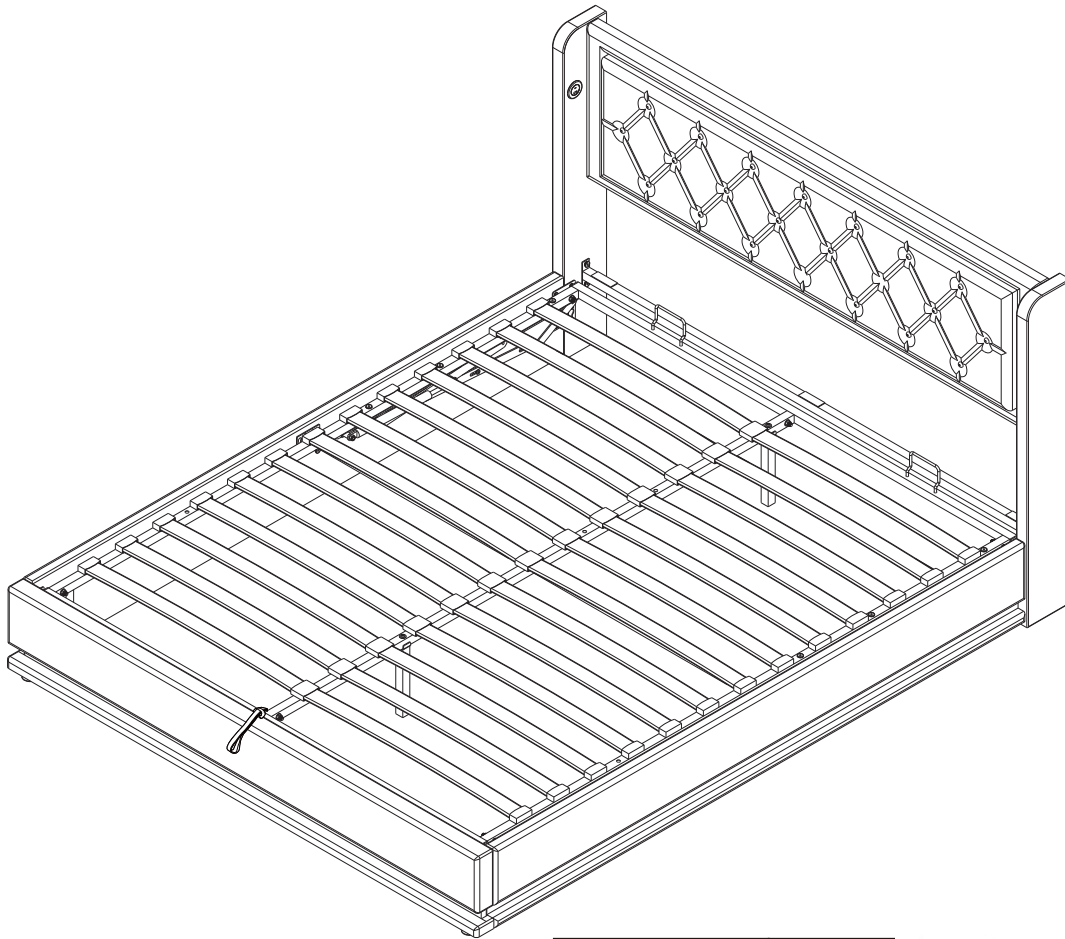

**⚠️ WARNUNG**  
AUSSERHALB DER REICHWEITE VON  
KINDERN AUFBEWAHREN  
Verschlucken kann zu Verätzungen,  
Weichteilperforationen und zum Tod führen.  
Schwere Verätzungen können innerhalb von zwei  
Stunden nach Einnahme auftreten. Suchen Sie  
sofort einen Arzt auf.



**CE RoHS**

- GB** This set comes in 3 boxes. If you do not receive a full set of 3 boxes, please contact our customer service.
- DE** Dieses Set wird in 3 Schachteln geliefert. Wenn Sie nicht ein komplettes Set von 3 Boxen erhalten, kontaktieren Sie bitte unseren Kundenservice.
- FR** Ce set est livré en 3 boîtes. Si vous ne recevez pas un jeu complet de 3 boîtes, veuillez contacter notre service clientèle.

## English

### IMPORTANT FOR GAS LIFT BEDS&MAINTAINANCE

- Please place the mattress on top of the bed frame.
- Please do not pull on the strap handles.
- Please press heavily to release the compressed gas.
- Periodically check all screw & fixings to ensure they are secure.
- When moving your product, carefully lift into place.
- Wipe clean with a slightly damp cloth- please do not use abrasive chemicals or bleach.
- Do NOT allow children to operate the lift mechanism.
- Do NOT allow children near the lift base when operating the mechanism.
- Do NOT stand inside the bed or the internal storage base.
- Do NOT overload the internal storage base.
- DO NOT jump on the product or any of its parts.

## Deutsch

### WICHTIG FÜR GASLIFT-BETTEN&WARTUNG

- Bitte legen Sie die Matratze oben auf den Bettrahmen.
- Bitte ziehen Sie nicht an den Gurtgriffen.
- Bitte drücken Sie kräftig, um das komprimierte Gas freizusetzen.
- Überprüfen Sie regelmäßig alle Schrauben und Befestigungen, um sicherzustellen, dass sie sicher sind.
- Wenn Sie Ihr Produkt bewegen, heben Sie es vorsichtig an seinen Platz.
- Mit einem leicht feuchten Tuch abwischen - bitte keine scheuernden Chemikalien oder Bleichmittel verwenden.
- Erlauben Sie Kindern NICHT, den Hebemechanismus zu bedienen.
- Lassen Sie Kinder NICHT in die Nähe des Liftsockels, wenn Sie den Mechanismus bedienen.
- Stellen Sie sich NICHT in das Bett oder in die Innenablage.
- Überlasten Sie den internen Liftsockel NICHT.
- Springen Sie NICHT auf das Produkt oder eines seiner Teile.

## Français

### IMPORTANT POUR LES LITS À RELEVAGE DE GAZ&MAINTENANCE

- Veuillez placer le matelas sur le dessus du cadre de lit.
- Ne tirez pas sur les poignées de la sangle.
- Appuyez fortement pour libérer le gaz comprimé.
- Vérifiez régulièrement que toutes les vis et fixations sont bien en place.
- Lorsque vous déplacez votre produit, soulevez-le avec précaution pour le mettre en place.
- Nettoyez avec un chiffon légèrement humide - n'utilisez pas de produits chimiques abrasifs ou d'eau de Javel.
- Ne laissez pas les enfants utiliser le mécanisme de levage.
- Ne laissez pas les enfants s'approcher de la base de levage lorsqu'ils actionnent le mécanisme.
- Ne vous tenez PAS à l'intérieur du lit ou de la base de stockage interne.
- Ne surchargez pas la base de stockage interne.
- Ne pas sauter sur le produit ou l'une de ses parties.

## Italiano

### IMPORTANTE PER I LETTI CON SOLLEVAMENTO A GAS E LA MANUTENZIONE

- Posizionare il materasso sopra la struttura del letto.
- Non tirare le maniglie della cinghia.
- Premere con forza per rilasciare il gas compresso.
- Controllare periodicamente tutte le viti e i fissaggi per assicurarsi che siano saldi.
- Quando si sposta il prodotto, sollevarlo con cautela.
- Pulire con un panno leggermente umido, senza usare prodotti chimici abrasivi o candeggina.
- NON permettere ai bambini di azionare il meccanismo di sollevamento.
- NON permettere ai bambini di avvicinarsi alla base di sollevamento quando si aziona il meccanismo.
- NON sostare all'interno del letto o della base di contenimento interna.
- NON sovraccaricare la base di contenimento interna.
- NON saltare sul prodotto o sulle sue parti.

## Español

### IMPORTANTE PARA LAS CAMAS ELEVADORAS DE GAS&MANTENIMIENTO

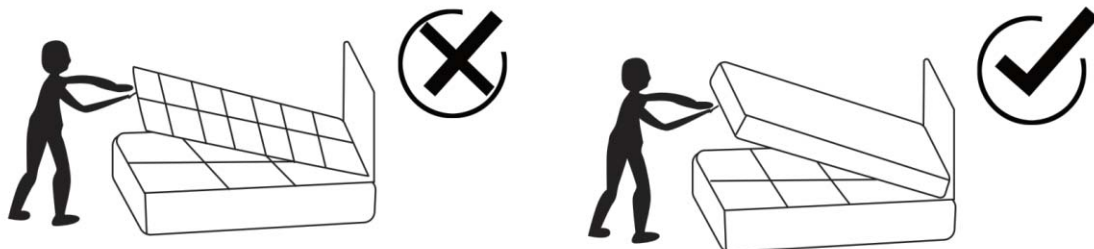

- Coloque el colchón sobre el somier.
- No tire de las asas de la correa.
- Presione con fuerza para liberar el gas comprimido.
- Compruebe periódicamente que todos los tornillos y fijaciones estén bien sujetos.
- Al mover el producto, levántelo con cuidado para colocarlo en su sitio.
- Limpie con un paño ligeramente humedecido; no utilice productos químicos abrasivos ni lejía.
- NO permita que los niños accionen el mecanismo de elevación.
- NO permita que los niños se acerquen a la base elevadora cuando accionen el mecanismo.
- NO se ponga de pie dentro de la cama o de la base de almacenamiento interna.
- NO sobrecargue el somier.
- NO salte sobre el producto ni sobre ninguna de sus piezas.



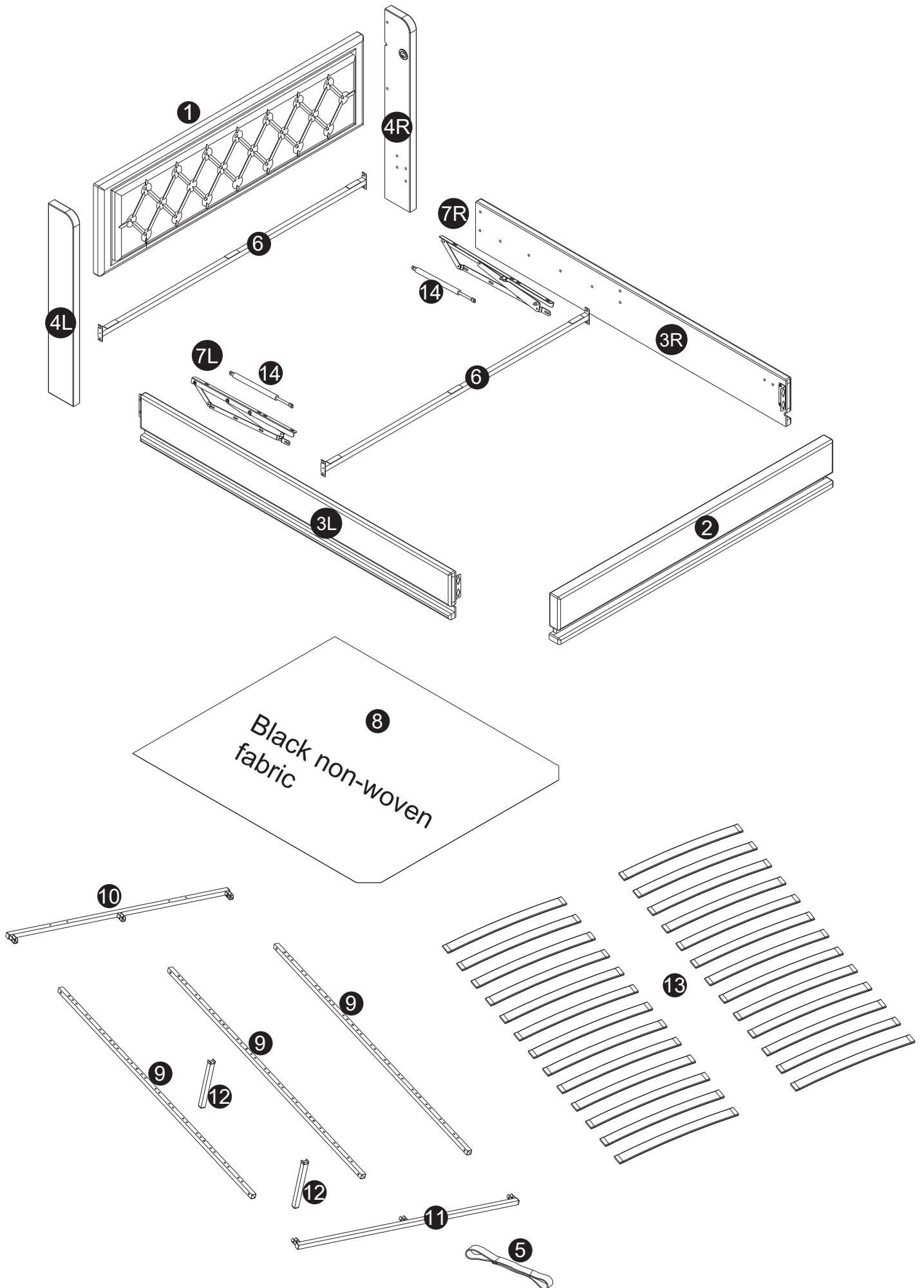

# Stückliste

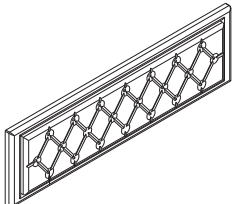

# N616P425595

1		X1	4L		X1	4R		X1
---	---	----	----	---	----	----	---	----

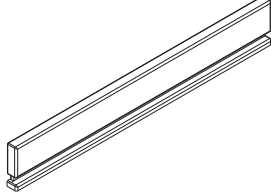
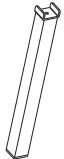
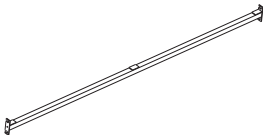

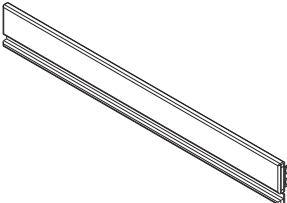
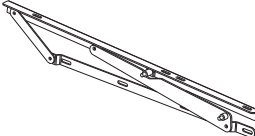
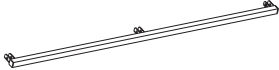
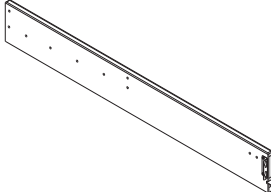
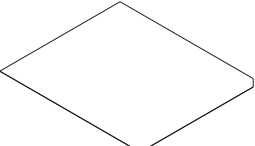
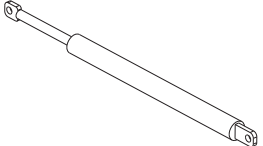
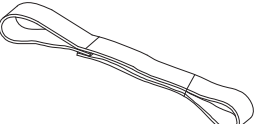
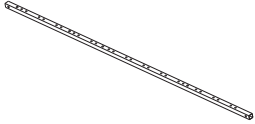
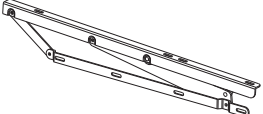
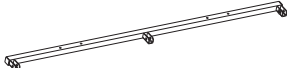

# N616P425596

2		X1	12		X2
6		X2	13		X26

# N616P425597

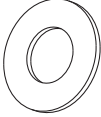
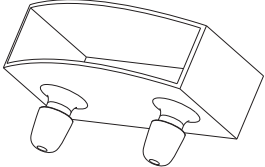
3L		X1	7R		X1	11		X1
3R		X1	8		X1	14		X2
5		X1	9		X3			
7L		X1	10		X1			

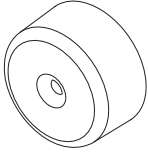
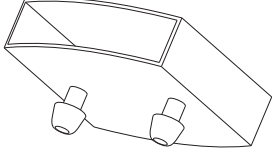
## Hardware List-Hardware-Liste-Liste du matériel N616P425595

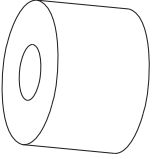
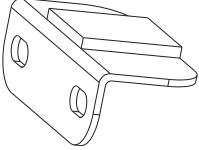
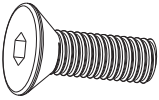
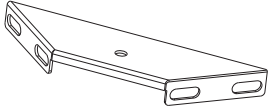
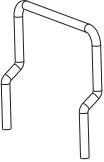
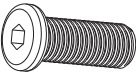
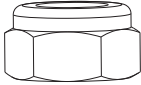
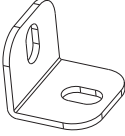
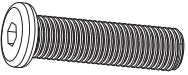
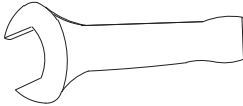
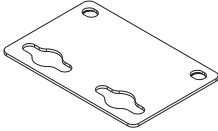
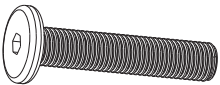
<b>A</b>		X1	<b>H</b>		X8	<b>P</b>		X26
<b>B</b>	 M4x40mm	X2	<b>J</b>		X2	<b>Q</b>		X13
<b>C</b>	 M6x35mm	X2	<b>K</b>		X8	<b>R</b>		X1
<b>D</b>	 M8x18mm	X8	<b>L</b>		X2	<b>S</b>		X2
<b>E</b>	 M8x20mm	X30	<b>M</b>	 M8	X16	<b>T</b>		X4
<b>F</b>	 M8x30mm	X8	<b>N</b>		X1	<b>U</b>		X2
<b>G</b>	 M8x40mm	X12						

## Hardware List-Hardware-Liste-Liste du matériel

### N616P425597

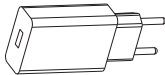
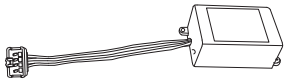
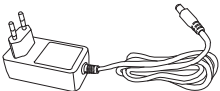
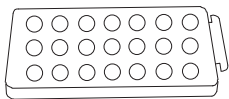
<b>V</b>		X1	<b>W</b>		X1	<b>X</b>		X1
<b>Y</b>		X1	<b>Z</b>		X1			

**1**

A x 1



D x 4



M8 x 18mm

E x 8



M8 x 20mm

T x 4

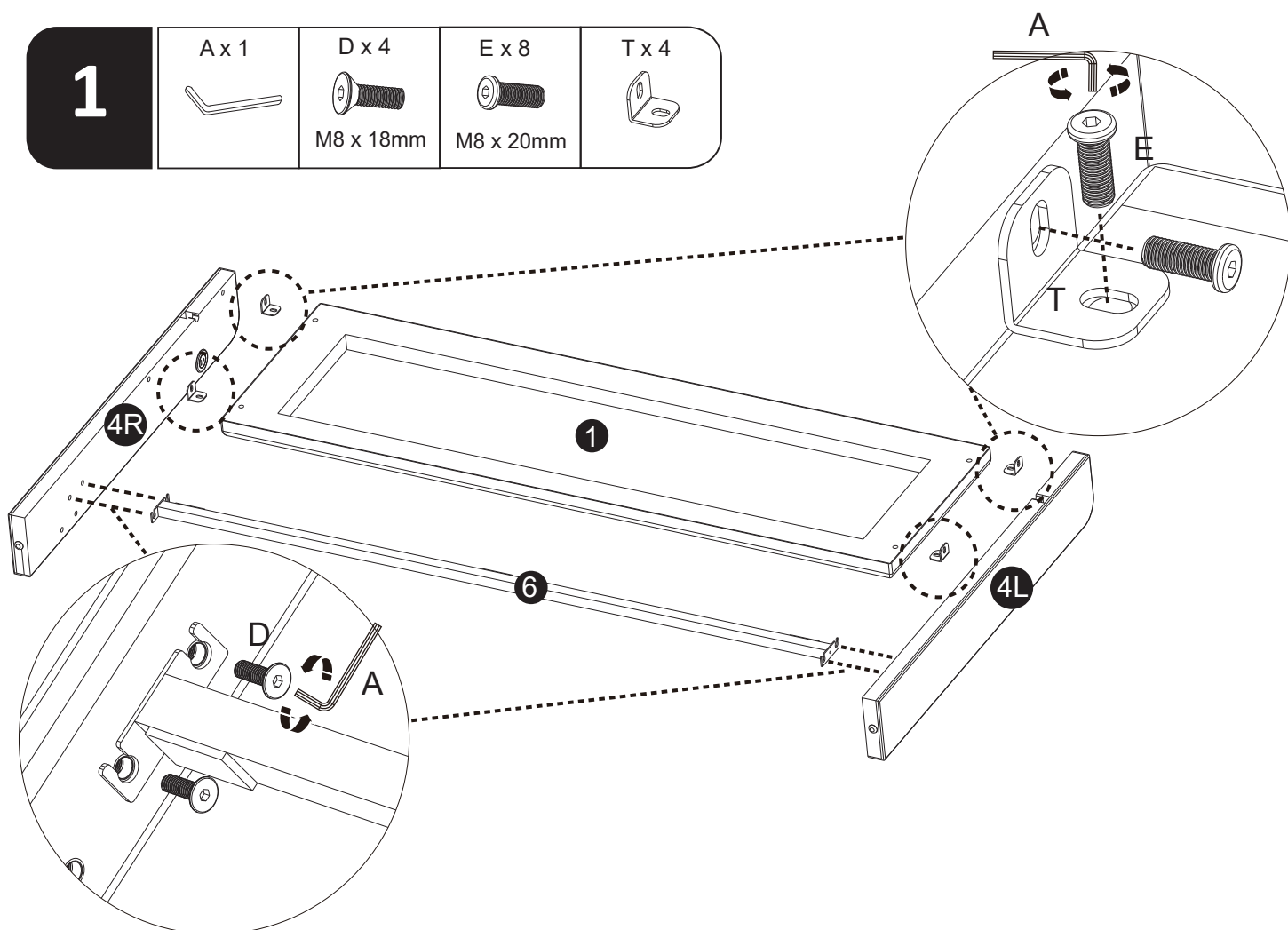
**2**

A x 1



B x 2



M4 x 40mm

E x 2



M8 x 20mm

J x 2



R x 1

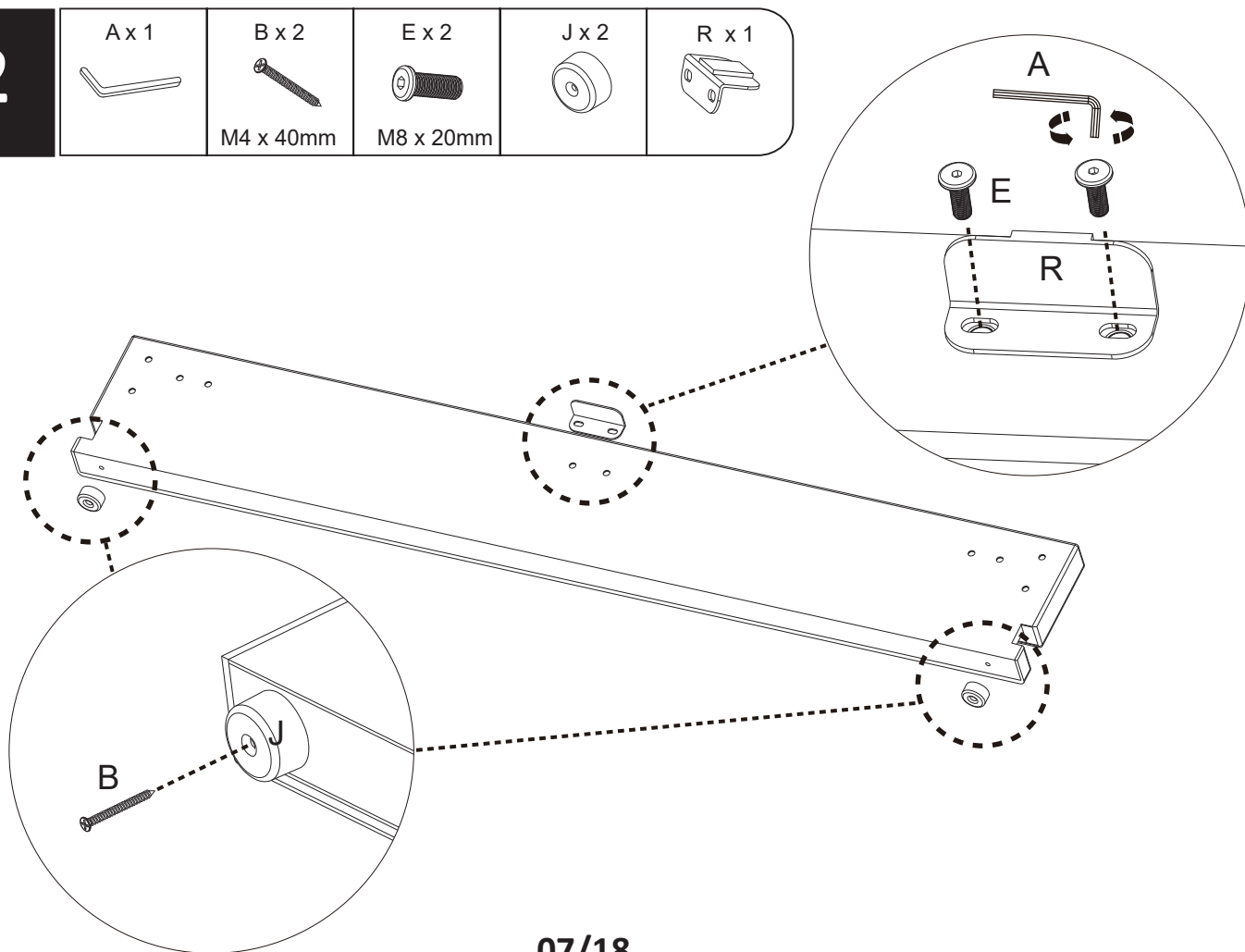

3

A x 1



E x 8



M8 x 20mm

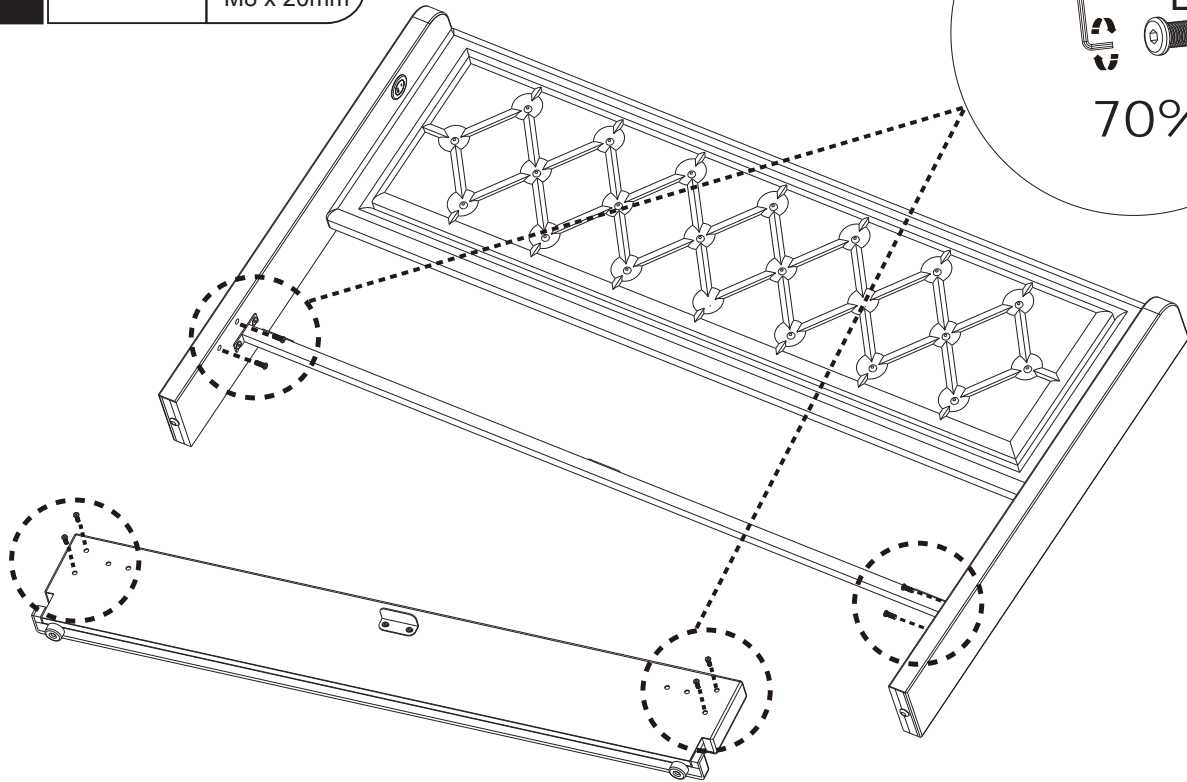
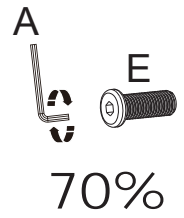

4

A x 1



D x 4



M8 x 18mm

E x 4



M8 x 20mm

U x 2

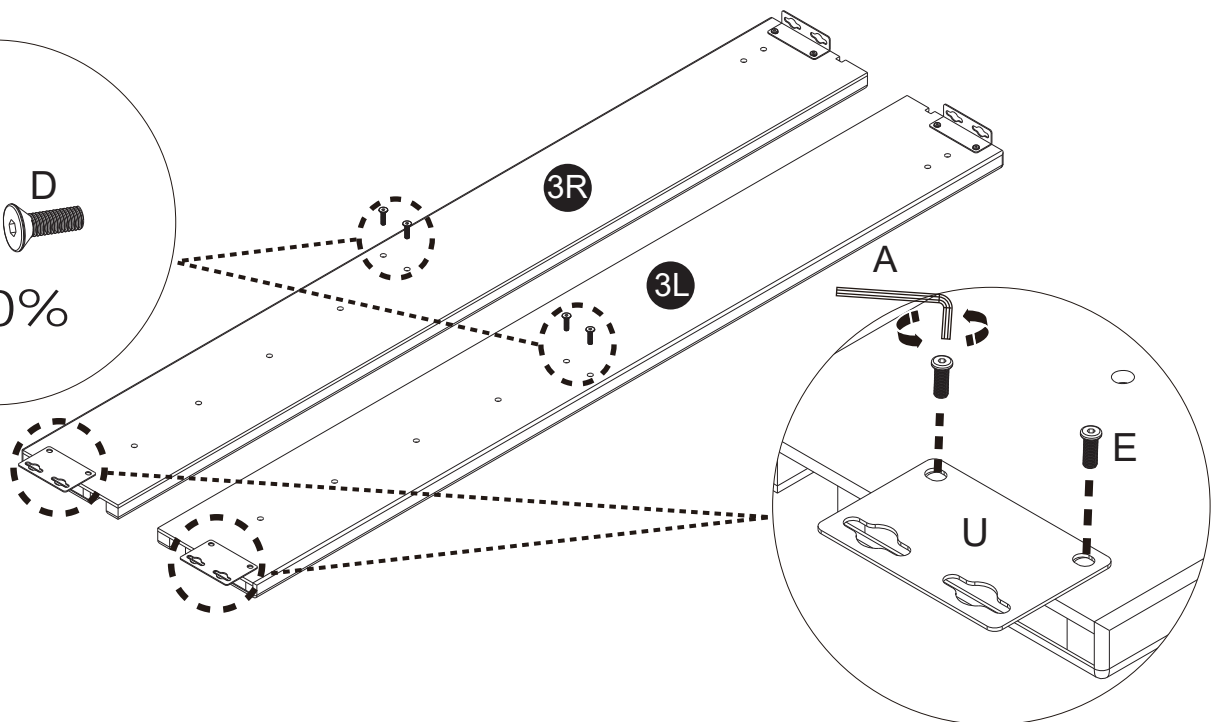
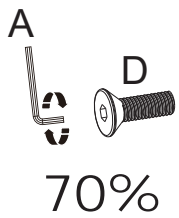

5

A x 1



F x 8



M8 x 30mm

K x 8

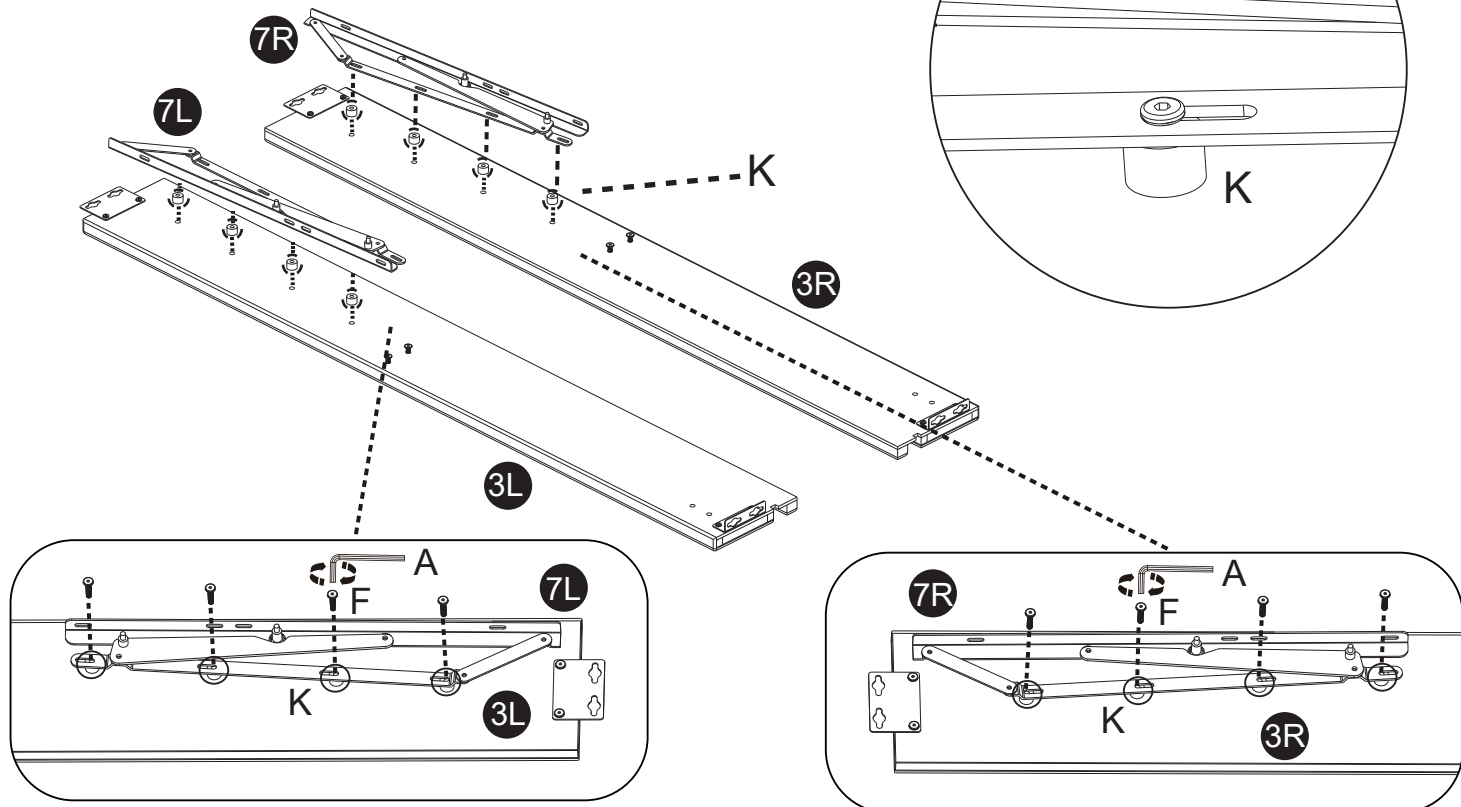

6

A x 1

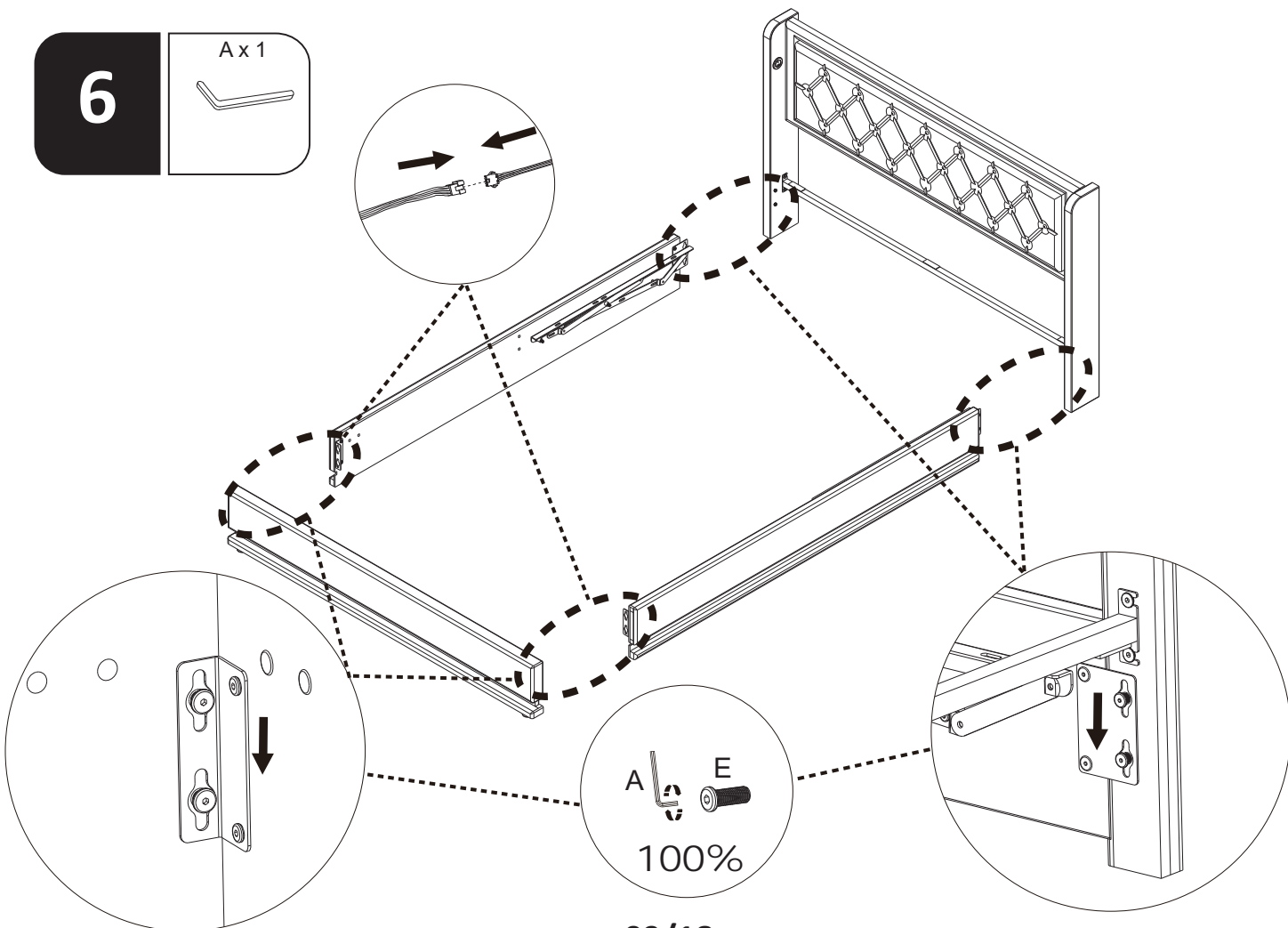

7

A x 1



E x 8



M8 x 20mm

L x 2

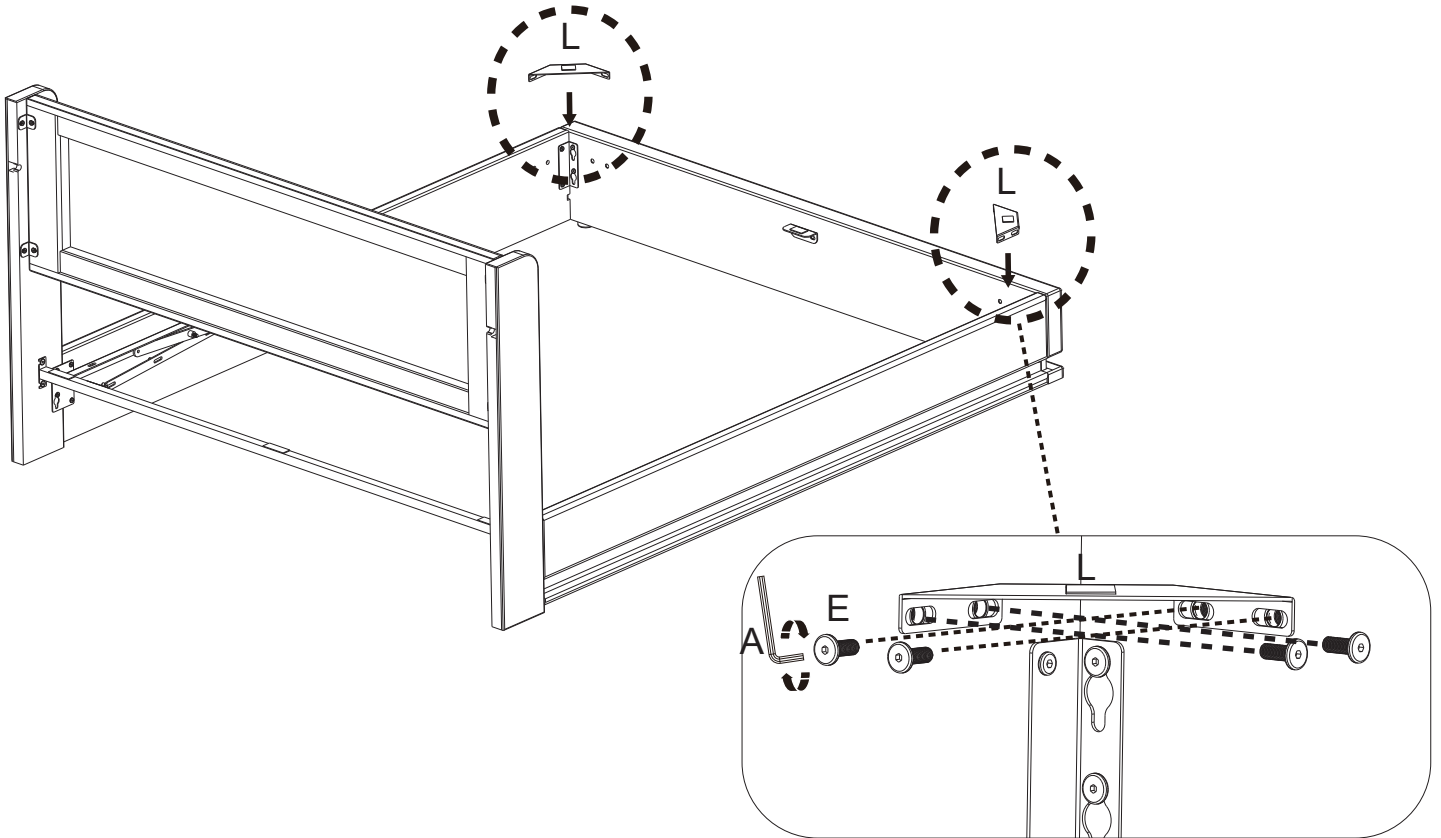

8

A x 1

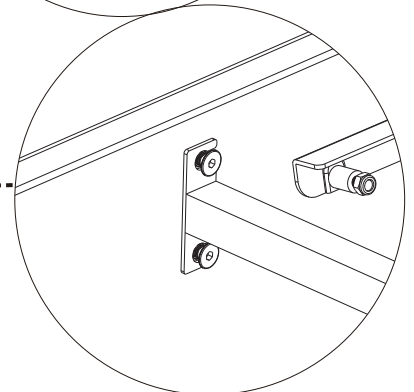
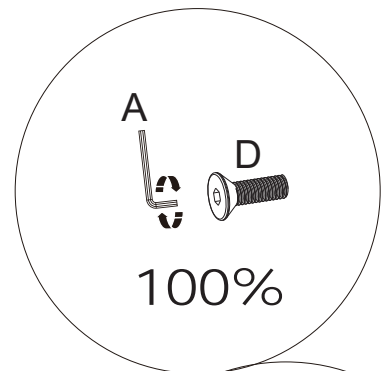
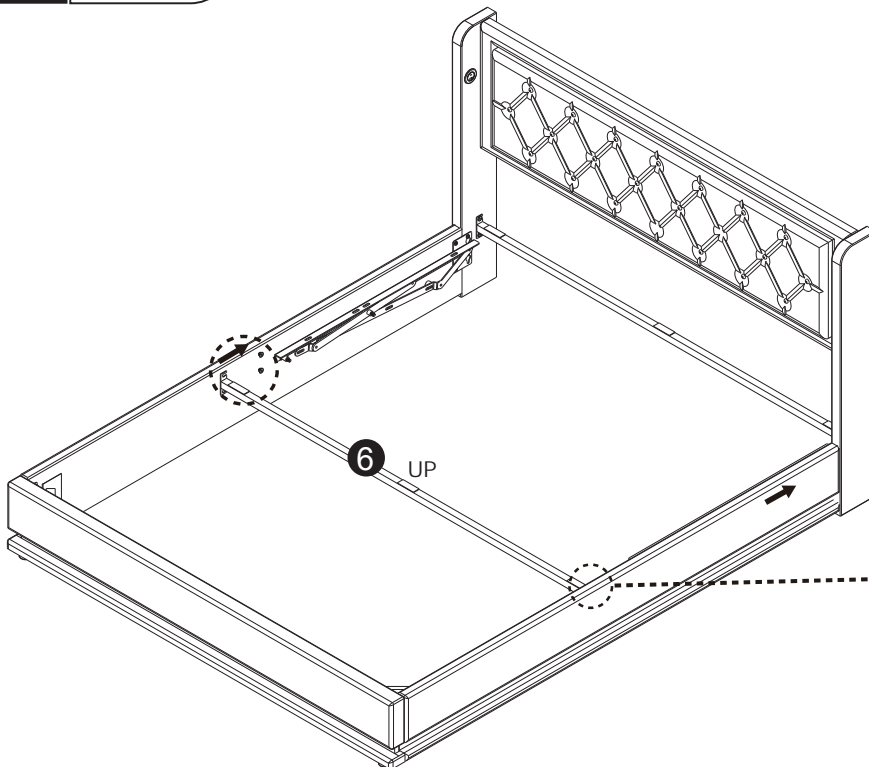

9

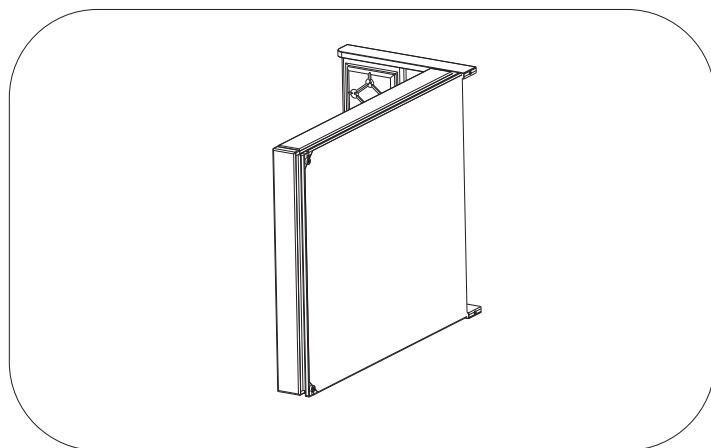
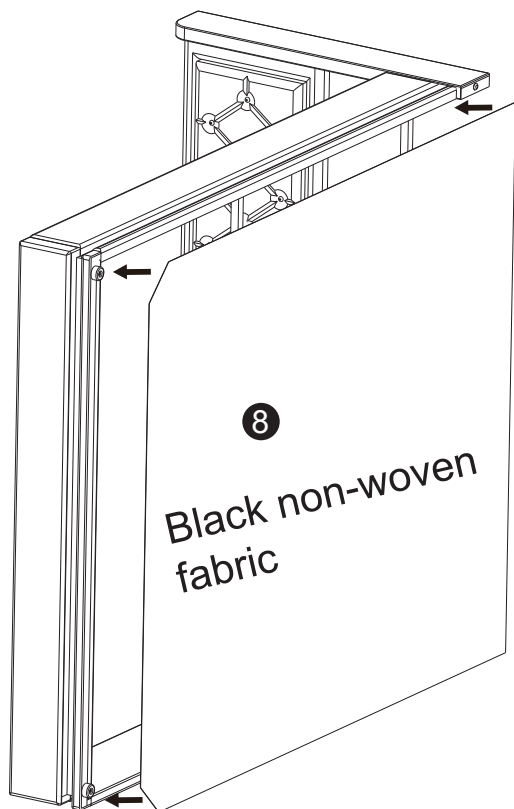

10

A x 1	G x 6 M8 x 40mm	H x 6	M x 6	N x 1

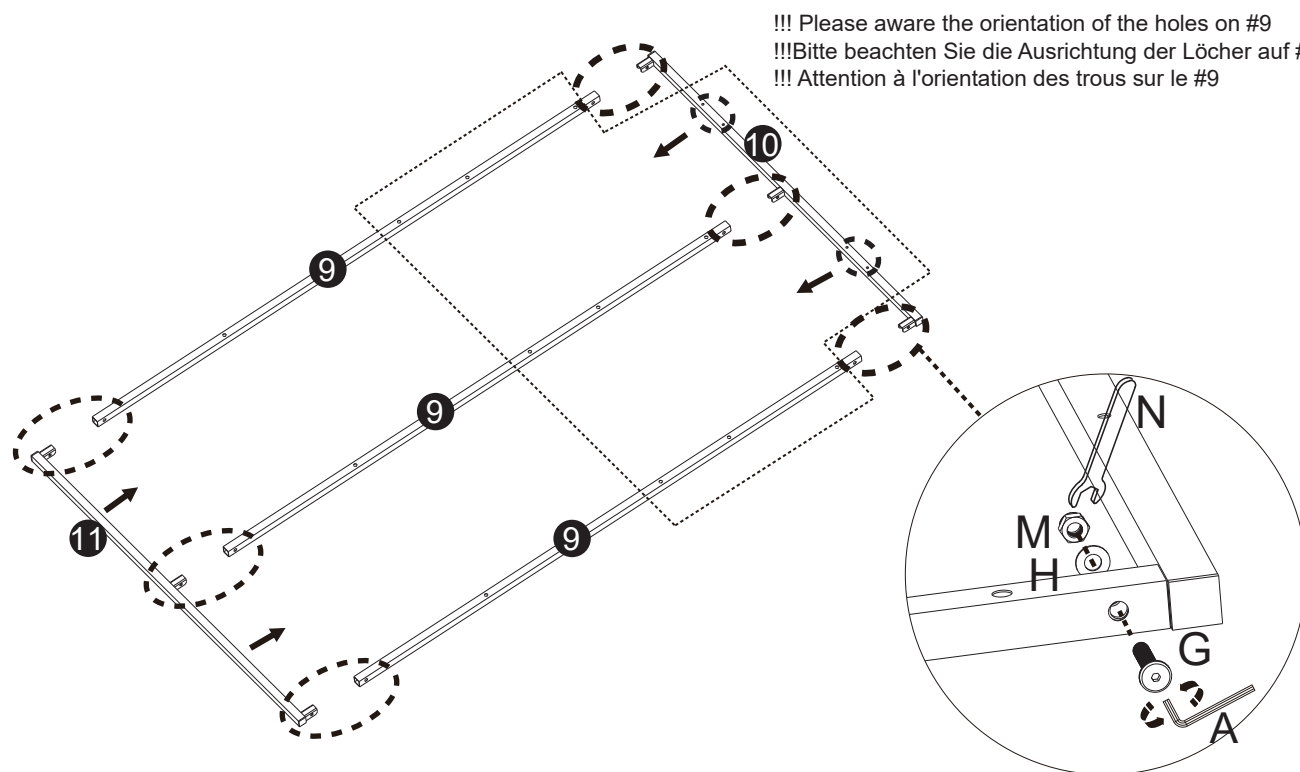

!!! Please aware the orientation of the holes on #9  
!!!Bitte beachten Sie die Ausrichtung der Löcher auf #9  
!!! Attention à l'orientation des trous sur le #9

11

A x 1



C x 2



M6 x 35mm

H x 2

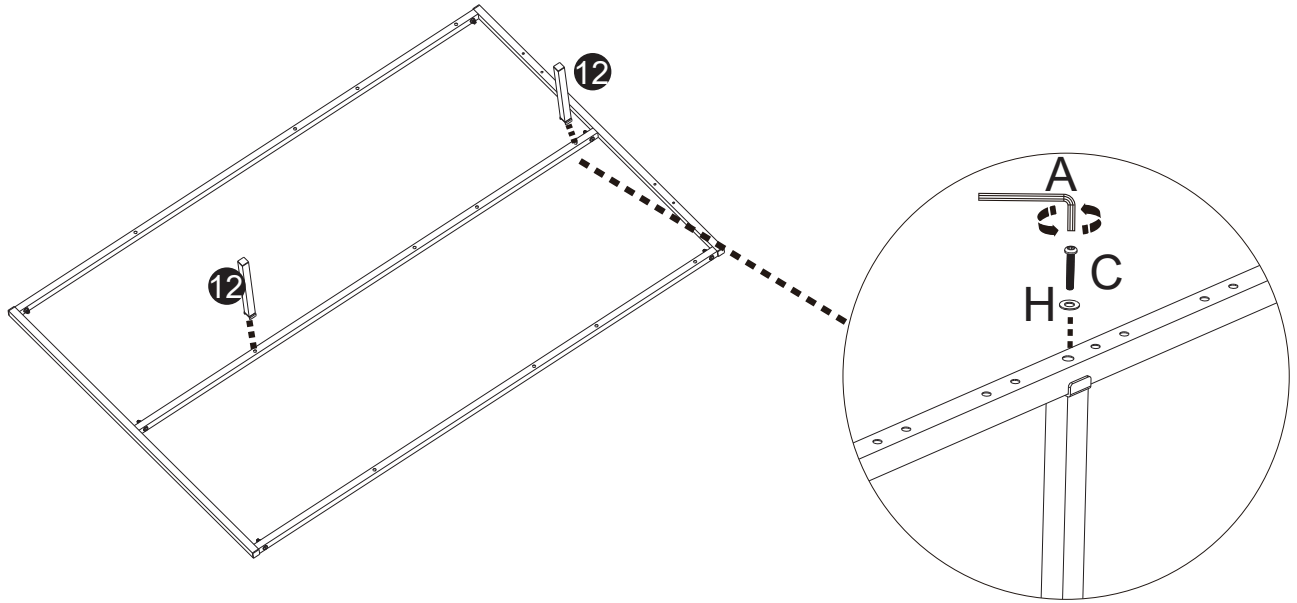

12

A x 1



G x 6



M8 x 40mm

M x 6



N x 1

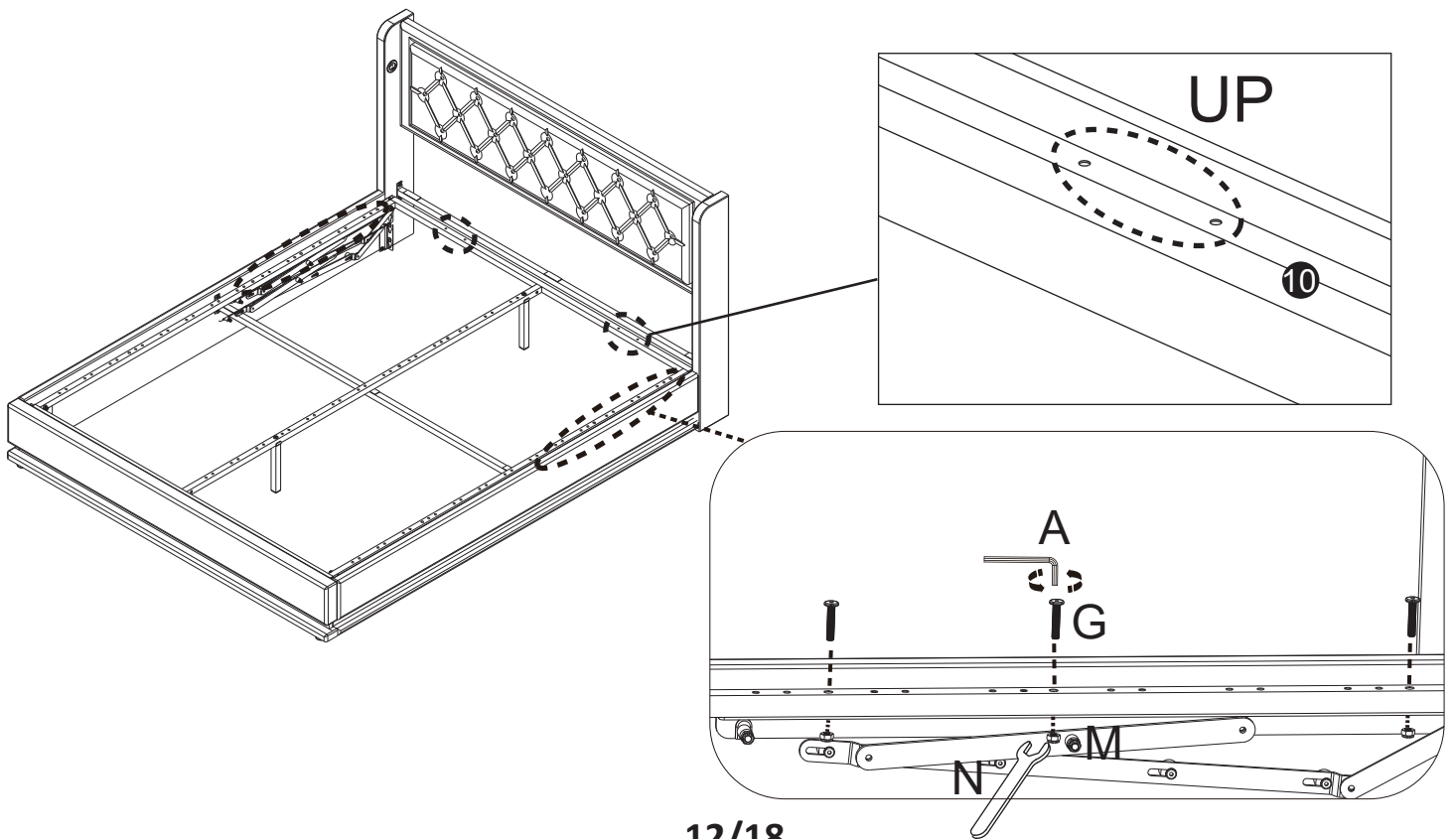

13

S x 2

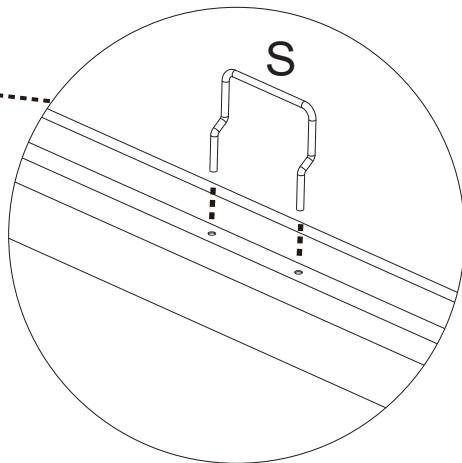
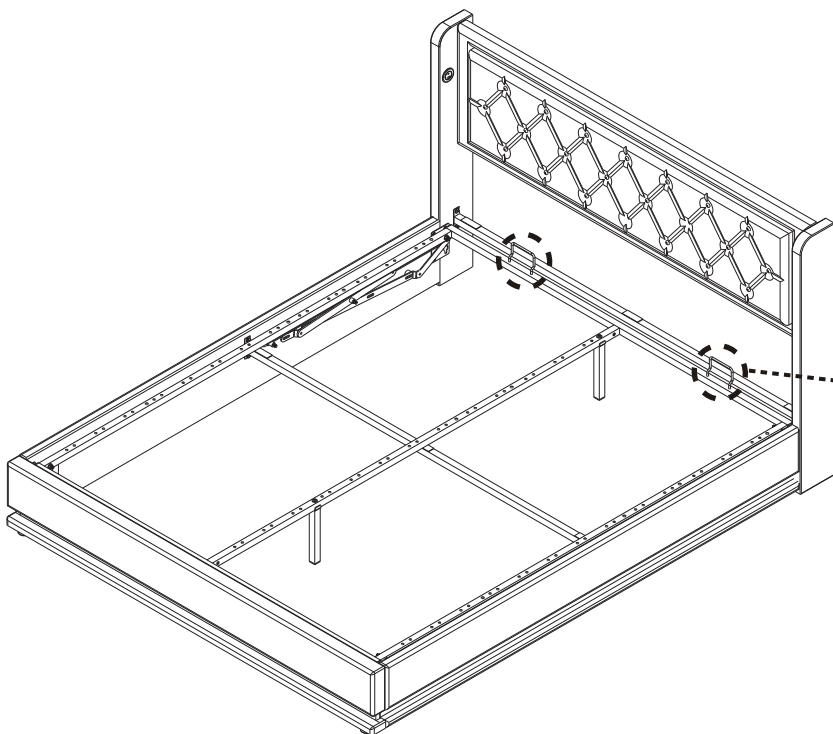

14

P x 26



Q x 13

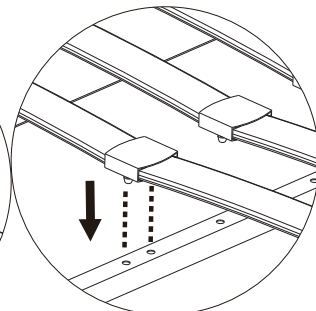
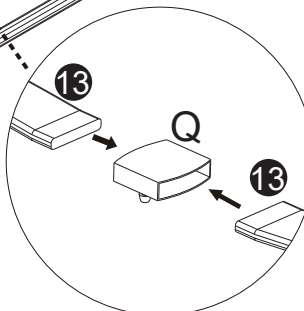
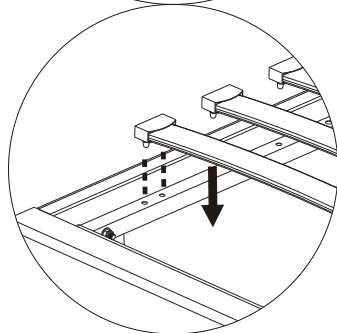
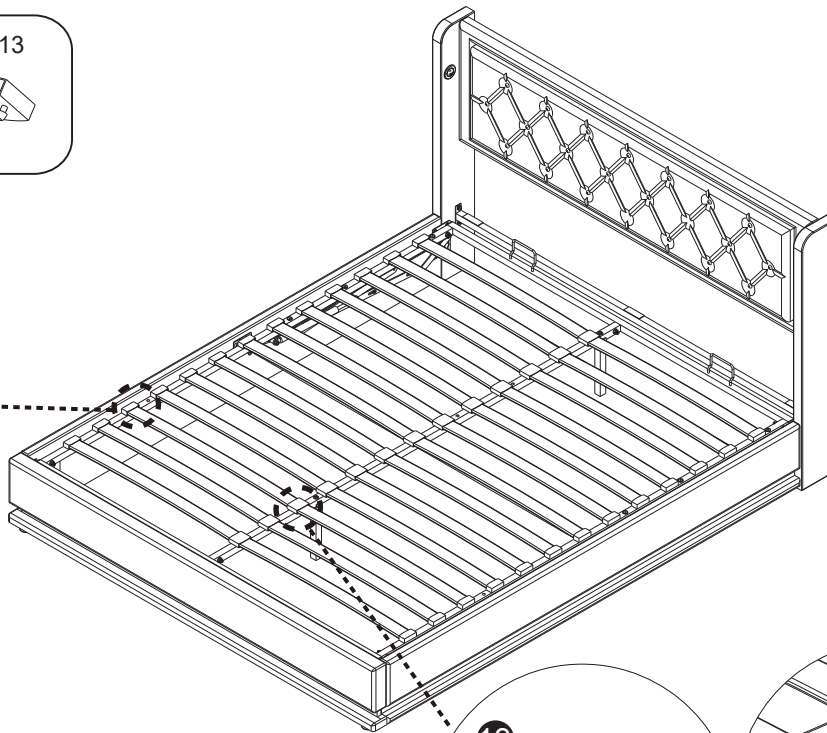
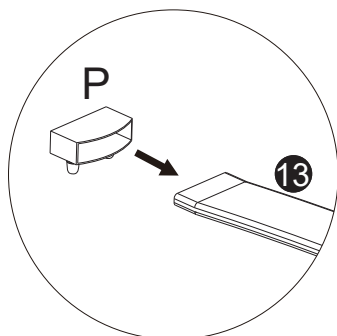

15

M x 4



N x 1

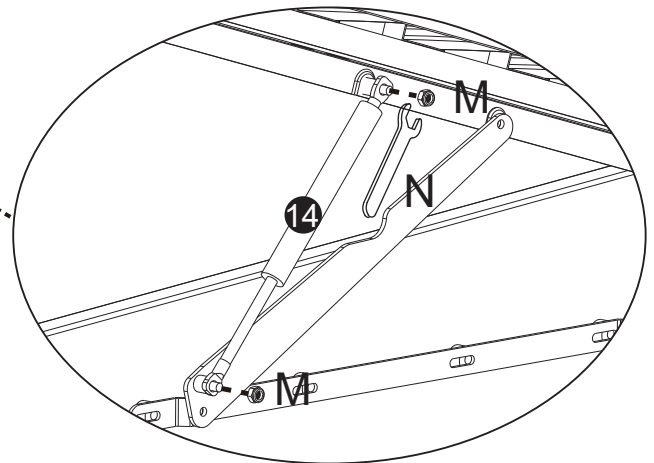
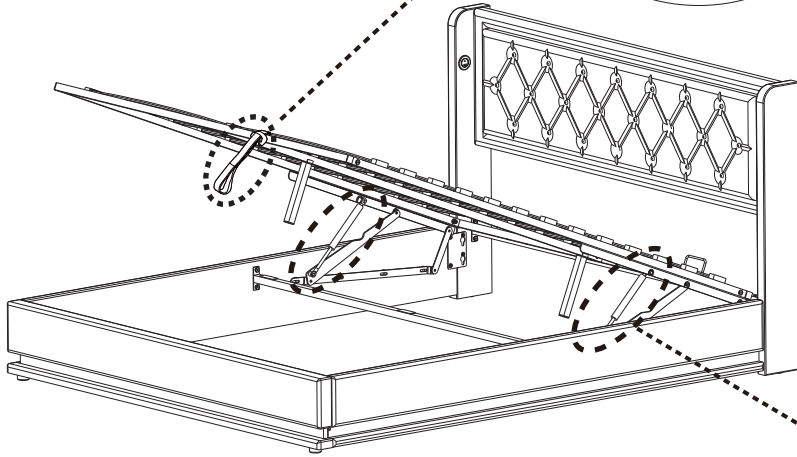
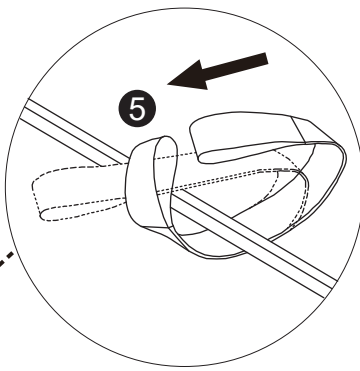

16

V x 1



W x 1

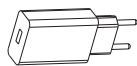

X x 1



Y x 1



Z x 1

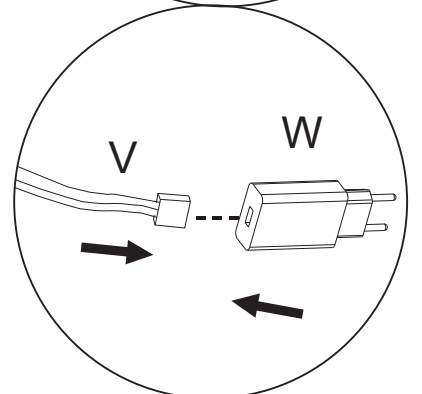
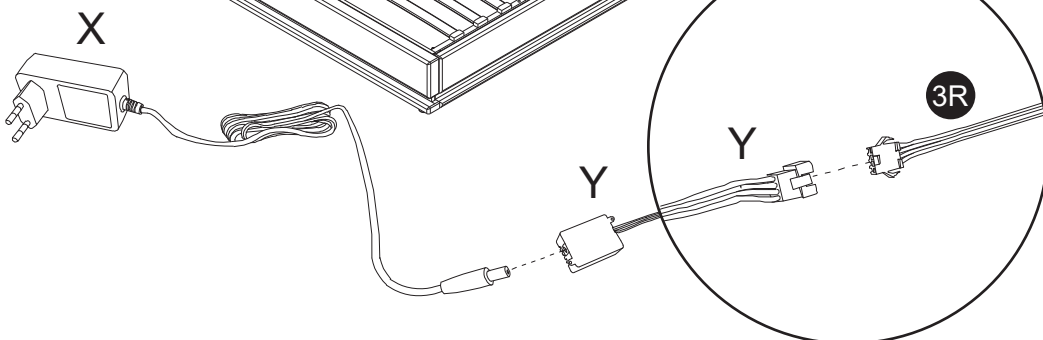
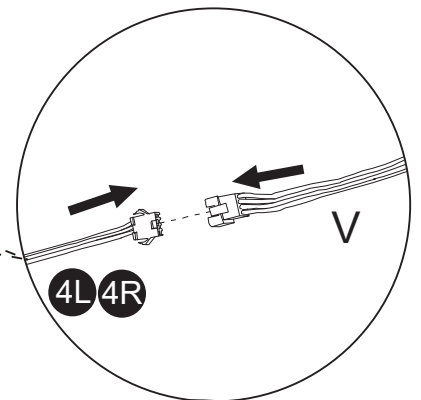
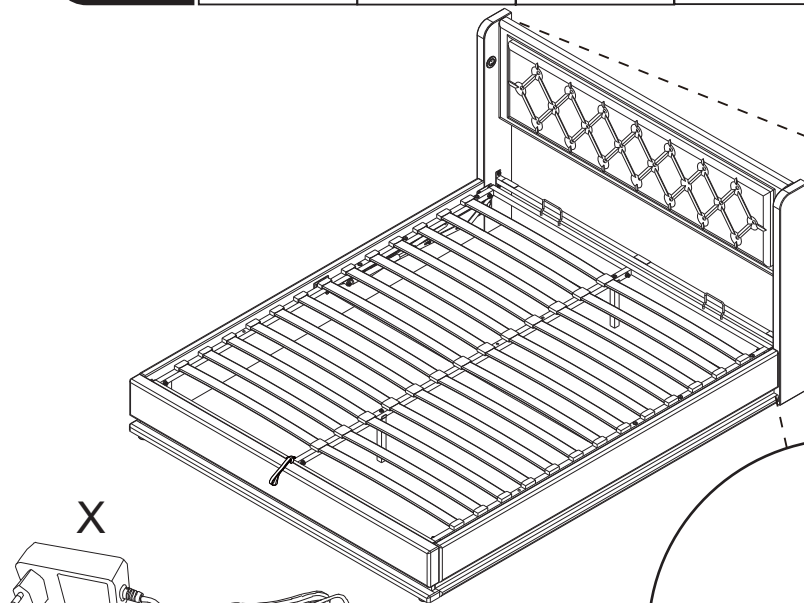
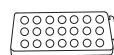

## LED light

If you can't let the lights work successfully, please check the following:

1. Please check the direction of the connect, try it in the opposite direction, according to the following picture.
2. Please check the remote control, it needs you to tear down the plastic septum before use it.
3. If one of the colors is not bright, please check whether the four wires in the plug are skewed, and move the main line to make the four wires flush.

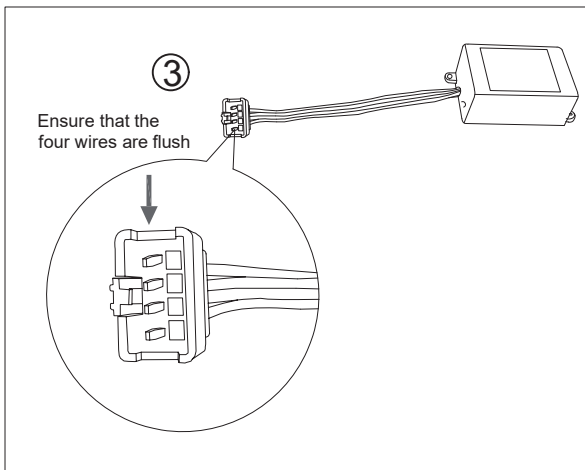
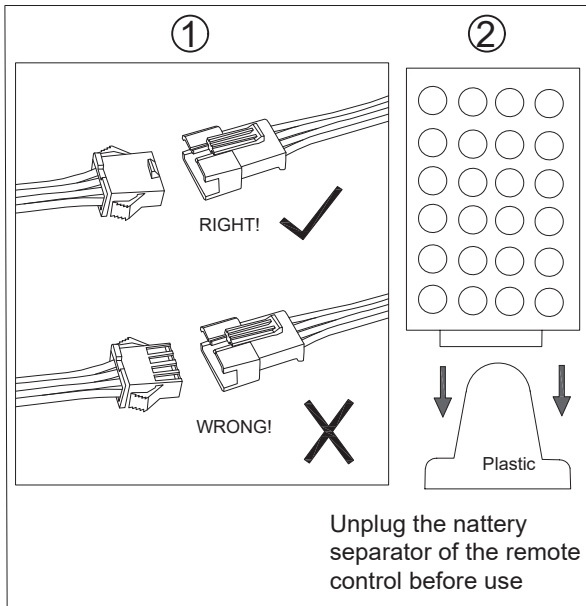

- 1 Please check the direction of the arrow
- 2 Please pull the plastic block out of the remote control
- 3 Please check whether the four wires of the plug are neat

## Operation Instructions of Controller

### I .Specifications:

Working temperature: -20-60 °C      Supply voltage: DC12V  
 Output: Three CMOS drain- open output      Connecting Mode: Common anode  
 Max load current: 2 A each color

### II .Control Method:

Adopt RF remoter to control the led controller, which has 24 buttons, the function of each button as the table below:

Brightness +(Speed up)	Brightness - (Speed down)	Off	On
Static red	Static green	Static blue	Static white
Static orange	Static pea green	Static dark blue	7 color jumpy change
Static dark yellow	Static cyan	Static brown	All fade out&fade in
Static yellow	Static light blue	Static pink	7 color fade change
Static straw yellow	Static sky blue	Static purple	3 base color jumpy

### III .Panel specification and connecting drawing as follows:

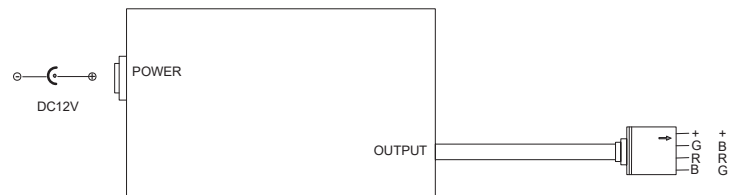

### IV .Warning:

1. Supply voltage of this product is DC12V never connect to DC24V or AC220V.
2. Never connect two wires directly in case of short circuit.
3. Lead wire should be connected correctly according to colors that connecting diagram offers.
4. Warranty of this product is one year, in this period we guarantee replacement or repairing with no charge, but exclude the artificial situation of damaged or overload working.

## ! WARNING

**THIS PRODUCT CONTAINS A BUTTON BATTERY**  
 If swallowed, a lithium button battery can cause severe or fatal injuries within 2 hours.  
 Keep batteries out of reach of children.  
 If you think batteries may have been swallowed or placed inside any part of the body, seek immediate medical attention.

**W-POWER**  
Certificate of Conformity

Certificate No. : WTY22030301001E  
Report No. : WTY22030301001E

**Applicant** : Shenzhen Fangxin Technology Co., Ltd  
**Address** : The third floor,Bldg9, A6 Areal, Tongfuyu Industrial Park, Shajing Street, Bao'an District, ShenZhen City, China  
**Product** : SWITCHING ADAPTER  
**Model No.** : FX18E-050300U1, FX18E-050300U3, FX18E-050300U9, FX18E-050300U12

Model No.	Rating input	Rating output	Output Power (W. Max)
FX18E-050300U1	100-240V~, 50/60Hz, 0.5A	5VDC, 3A; 9VDC, 2A; 12VDC, 1.5A.	18.0
FX18E-050300U3		5VDC, 3A	15.0
FX18E-050300U9		9VDC, 2A	18.0
FX18E-050300U12		12VDC, 1.5A	18.0

**Test Standard(s)** : EN 55032:2015/A11:2020  
EN 55035:2017/A11:2020  
EN IEC61000-3-2:2019/A1:2021  
EN 61000-3-3:2013/A1:2019

This certificate of conformity is based on an evaluation of a sample of the above mentioned product. Technical Report and documentation are at the License Applicant's disposal. This is to certify that the tested sample is in conformity with the Directive 2014/30/EU relating to electromagnetic compatibility. This certificate does not imply assessment of the series-production of the product. The Applicant of the certificate is authorized to use this certificate in connection with the EC declaration of conformity according to Annex IV of the Directive.



Hero wu  
(Manager)  
Mar. 18, 2022

**W-POWER**  
Certificate of Conformity

Certificate No. : WTY22030301001S  
Report No. : WTY22030301001S

**Applicant** : Shenzhen Fangxin Technology Co. Ltd.  
**Address** : The third floor,Bldg9, A6 Areal, Tongfuyu Industrial Park, Shajing Street, Bao'an District, ShenZhen City, China  
**Product** : USB Power ADAPTER

**Brand Name** : Fxin  
**Model No.** : FX18E-050300U1, FX18E-050300U3, FX18E-050300U9, FX18E-050300U12

**Ratings** : Input: 100-240V~, 50/60Hz, 0.5A, Class II apparatus  
Output: See report for details.

**Test Standard(s)** : EN 62368-1:2014+A11:2017

This certificate of conformity is based on an evaluation of a sample of the above mentioned product. Technical Report and documentation are at the Licence Applicants disposal. Once compliance with all product relevant mark regulations are verified, including any relevant e.g. risk assessment and production control, the manufacturer may indicate compliance by signing a Declaration of Conformity themselves and applying the mark to products identical to the tested sample(s).



Hero wu  
(Manager)  
Mar. 23, 22

Shenzhen Watt Power Testing Institute Co., Ltd.  
Tel: (86)-755-85297065 Fax: (86)-755-21500685  
Http://www.wtypower.com Mail: test@wtypower.com  
Area A, Floor 1, Building C, Guosheng Industrial Park, No. 101 Junxin Road, Shimajing community, Guanlan Street, Longhua New District, Shenzhen

CERTIFICATE



of Conformity  
Low Voltage Directive 2014/35/EU

Registration No.: AN 50489215 0001

Report No.: 60387434 001

**Holder:** SHENZHEN BOYAXUAN TECHNOLOGY DEVELOPMENT CO., LTD.  
3/F, 1st Building,  
Xing Wei (Feng Huang)  
Third Industrial Area, Fuyong Street,  
Shenzhen  
518100 Guangdong  
P.R. China

**Product:** Power Supply  
(AC/DC ADAPTER)

**Identification:** Type Designation: BYX2-XXXYYYE, BYX3-XXXYYYZ (BOYAXUAN)  
For detail of the variables XXX, YYY and Z refer to TÜV Rheinland license S 50489196 pages 0001-0002.  
Serial No.: n.a.  
Remark: Issued in conjunction with above TÜV Rheinland license.

This certificate of conformity is based on an evaluation of a sample of the above mentioned product. Technical Report and documentation are at the Licence Holder's disposal. This is to certify that the tested sample is in conformity with Annex I of Council Directive 2014/35/EU, referred to as the Low Voltage Directive. This certificate does not imply assessment of the series-production of the product and does not permit the use of a TÜV Rheinland mark of conformity. The holder of the certificate is authorized to use this certificate in connection with the EC declaration of conformity according to Annex IV of the Directive.



Certification Body  
Dipl.-Ing. Univ. S. O. Steinke

Date 25.01.2021

TÜV Rheinland LGA Products GmbH - Tillystraße 2 - 90431 Nürnberg

CE The CE marking may be used if all relevant and effective EC Directives are complied with. CE

Certificate of Conformity

Certificate Number: DL-20240403030C

**Applicant:** Shenzhen Blue The Light Technology co., Ltd.  
Floor 4, Building 2, Hongxing Industrial Park, Yuanling Village, Shiyao Town, Baoan District, Shenzhen

**Manufacturer:** Shenzhen Blue The Light Technology co., Ltd.  
Floor 4, Building 2, Hongxing Industrial Park, Yuanling Village, Shiyao Town, Baoan District, Shenzhen

**Product:** 24 key RF RF controller

**Model No.:** LG-24-RF-12V

**Test Standard:** EN 55032:2015+A1:2020  
EN IEC 61000-3-2:2019+A1:2021, EN 61000-3-3:2013+A1:2019+A2:2021  
EN 55035:2017+A11:2020  
EN 61000-4-2:2009, EN IEC 61000-4-3:2020, EN 61000-4-4:2012,  
EN 61000-4-5:2014+A1:2017, EN IEC 61000-4-6:2022,  
EN 61000-4-8:2010, EN IEC 61000-4-11:2020

The EUT described above has been tested by us with the listed standards and found in compliance with the council EMC directive 2014/30/EU. It is possible to use CE marking to demonstrate the compliance with this EMC Directive. It is only valid in connection with the test report number: DL-20240403030E.



This certificate of conformity is based on a single evaluation of the submitted sample(s) of the above mentioned product. It does not imply an assessment of the whole product and relevant. Without the written approval, it is not permitted to use the test lab's logo.



# Certificate of Compliance

Certificate Number: DL-2022072129C

**Applicant:** Eyue Technology Co., Ltd  
2F, XINWANGYUAN HIGH-TECH INDUSTRIAL PARK, ZHANGMUTOU TOWN, DONGGUAN, GUANGDONG, 523627 CHINA

**Manufacturer:** Eyue Technology Co., Ltd  
2F, XINWANGYUAN HIGH-TECH INDUSTRIAL PARK, ZHANGMUTOU TOWN, DONGGUAN, GUANGDONG, 523627 CHINA

**Product:** USB Charger

**M/N:** EY-U222  
EY-U112, EY-U212, EY-U312, EY-U412, EY-U612, EY-U122, EY-U322, EY-U422, EY-U132, EY-U232, EY-U332, EY-U432, EY-U142, EY-U242, EY-U342, EY-U442, EY-U152, EY-U252, EY-U352, EY-U452, EY-UXXX, EY-U512, EY-U712, EY-U812, EY-U522, EY-U622, EY-U722, EY-U822, EY-U532, EY-U632, EY-U732, EY-U832, EY-U542, EY-U642, EY-U742, EY-U842, EY-U552, EY-U652, EY-U752, EY-U852

**Test Standard:** EN 55015:2013+A1:2015  
EN 61000-3-2:2014, EN 61000-3-3:2013  
EN 61547:2009  
EN 61000-4-2:2009, EN 61000-4-3: 2006+A1:2008+A2:2010  
EN 61000-4-4:2012, EN 61000-4-5:2014, EN 61000-4-6:2014  
EN 61000-4-8:2010, EN 61000-4-11:2004

The EUT described above has been tested by us with the listed standards and found in compliance with the council EMC directive 2014/30/EU. It is possible to use CE marking to demonstrate the compliance with this EMC Directive. It is only valid in connection with the test report number: DL-2022072129E.



# Certificate of Conformity

Certificate Number: DL-20240403012C

**Applicant:** Shenzhen Blue The Light Technology co., Ltd.  
Floor 4, Building 2, Hongxing Industrial Park, Yuanling Village, Shiyuan Town, Baoan District, Shenzhen

**Manufacturer:** Shenzhen Blue The Light Technology co., Ltd.  
Floor 4, Building 2, Hongxing Industrial Park, Yuanling Village, Shiyuan Town, Baoan District, Shenzhen

**Product:** 24 key RF controller

**Model No.:** LG-24-RF-12V

**Test Standard:** IEC 62321-3-1:2013; IEC 62321-4:2013+A1:2017;  
IEC 62321-5:2013; IEC 62321-6:2015; IEC 62321-7-1:2015;  
IEC 62321-7-2:2017; IEC 62321-8:2017

The EUT described above has been consolidated by us and found in compliance with the council RoHS Directive (EU) 2015/863 amending Annex II to Directive 2011/65/EU.

The certificate applies to the tested sample above mentioned only and shall not imply an assessment of the whole production. It is only valid in connection with the test report number: DL-20240403012R.

# RoHS



This certificate of conformity is based on a single evaluation of the submitted sample(s) of the above mentioned product. It does not imply an assessment of the whole product and relevant. Without the written approval, it is not permitted to use the test lab's logs.



## CERTIFICATE OF CONFORMITY

No.: AZT24072647C-EV0

**Report No.:** AZT24072647C-E0  
**Applicant:** ShenZhen BoYaXuan Technology Development CO., LTD  
**Address:** 3/F, 1st Building, Xing Wei (Feng Huang) Third Industrial Area, Fuyong Street, 518103 Shenzhen, PEOPLE'S REPUBLIC OF CHINA  
**Sample Name:** AC/DC Adapter  
**Trade Mark:** BOYAXUAN  
**Model No.:** Please refer to next page(s).

The submitted products have been tested by us with the listed standards and found in compliance with the following European Directives:

**RoHS Directive 2011/65/EU Annex II amending Directive (EU)2015/863**

**The Restriction of The Use of Certain Hazardous Substances In Electrical and Electronic Equipment**

The standard(s) used for showing compliance with the essential requirements:

**Test method(s)**

IEC 62321-3-1:2013; IEC 62321-5:2013; IEC 62321-4:2013+AMD1:2017 CSV; IEC 62321-6:2015;

IEC 62321-7-1:2015; IEC 62321-7-2:2017; IEC 62321-8:2017



Date of Issue: August 05, 2024

*Jack*  
Signed for and on behalf of AZT

According to the applicant's requirements, the materials selected for submitting the samples will be tested. The test results are only responsible for the submitted samples. This certificate is a part of the complete test report and should be used in conjunction with the test report. It is based on the conformity assessment of the submitted samples.



Model No.:
BYX2-XXXXXX, BYX2-XXXXXX, BYX3-XXXXXX, BYX3-XXXXXX, BYX3-XXXXXX, BYX4-XXXXXX, BYX4-XXXXXX, BYX4-XXXXXX, BYX-XXXXXX, BYX-XXXXXX, BYX-XXXXXX, BYX-XXXXXX, BYX6-XXXXXX, BYX6-XXXXXX.
035-120, stands for output voltage from 3.5V to 12V, YYYY=0010-650 stands for output current from 0.01A to 0.2A. Max.7.5W
050-252, stands for output voltage from 5V to 25.2V, YYYY=0010-4000 stands for output current from 0.01A to 4.0A. Max.24W
050-252, stands for output voltage from 5V to 25.2V, YYYY=0010-7200 stands for output current from 0.01A to 7.2A. Max.60W
050-480, stands for output voltage from 5V to 48V, YYYY=0010-10000 stands for output current from 0.01A to 10.0A. Max.75W
090-480, stands for output voltage from 9V to 48V, YYYY=0010-10000 stands for output current from 0.01A to 10.0A. Max.151.2W
Z=B, E, B, J, CH, M, U, K, G, Z, G. "U" represents British plug, "E" represent European plug, "A" represent Australian "M" means replaceable plug type, "J" represents Japanese plug, "C" represents China plug, "U" represents United States of America plug, "K" represents Korea plug, "zG""G" stands for desktop triple plug.



## EN:Battery Safety Instructions

1. Do not dispose of used button batteries or remote controls in household trash. To protect the environment and prevent hazardous leakage, please follow these guidelines:
2. Remove button batteries after use and take them to a local battery recycling point or hazardous waste collection site.
3. Do not burn or dismantle the batteries to avoid explosion or toxic release.
4. If the remote control is no longer in use, please deliver it to a certified electronics recycling facility to promote resource reuse.
5. Keep out of reach of children to prevent accidental ingestion or injury.
6. This product does not include batteries; please purchase them separately. The compatible button cell model for the remote control is CR2025 3V
7. If the light strip is not working, please try replacing the battery first. If the issue persists, contact the seller for assistance.
8. **Keep the remote control away from children — keep it away from children!** If the battery is accidentally swallowed, seek medical attention immediately.

## DE: Batteriesicherheitshinweise

1. Entsorgen Sie gebrauchte Knopfzellen oder Fernbedienungen nicht im Hausmüll. Um die Umwelt zu schützen und gefährliche Leckagen zu vermeiden, beachten Sie bitte die folgenden Hinweise:
2. Entfernen Sie die Knopfzelle nach dem Gebrauch und bringen Sie sie zu einer örtlichen Batteriesammelstelle oder einem Sondermüllentsorgungszentrum.
3. Batterien nicht verbrennen oder zerlegen, um Explosionen oder die Freisetzung giftiger Stoffe zu vermeiden.
4. Wenn die Fernbedienung nicht mehr verwendet wird, bringen Sie sie zu einer zertifizierten Elektronik-Recyclingstelle, um eine Wiederverwertung zu ermöglichen.
5. Außerhalb der Reichweite von Kindern aufbewahren, um versehentliches Verschlucken oder Verletzungen zu verhindern.
6. Dieses Produkt enthält keine Batterien. Bitte kaufen Sie diese separat. Das kompatible Knopfzellenmodell für die Fernbedienung ist CR2025 3V
7. Wenn der Lichtstreifen nicht funktioniert, versuchen Sie zunächst, die Batterie zu wechseln. Besteht das Problem weiterhin, kontaktieren Sie bitte den Verkäufer.
8. **Halten Sie die Fernbedienung unbedingt von Kindern fern — unbedingt fernhalten!** Wird die Batterie versehentlich verschluckt, suchen Sie sofort medizinische Hilfe auf.

## FR:Instructions de sécurité pour les piles

1. Ne jetez pas les piles bouton usagées ou les télécommandes à la poubelle ménagère. Pour protéger l' environnement et éviter tout risque de fuite dangereuse, veuillez suivre les consignes suivantes :
  2. Retirez les piles bouton après usage et déposez-les dans un point de collecte local ou un centre de déchets dangereux.
  3. Ne brûlez pas et ne démontez pas les piles, cela pourrait entraîner une explosion ou libérer des substances toxiques.
  4. Si la télécommande n'est plus utilisée, déposez-la dans un centre de recyclage agréé pour appareils électroniques, afin de favoriser la réutilisation des ressources.
  5. Gardez hors de portée des enfants pour éviter tout risque d'ingestion accidentelle ou de blessure.
- 6.Ce produit ne contient pas de pile. Veuillez l'acheter séparément. Le modèle de pile bouton compatible pour la télécommande est CR2025 3V
- 7.Si le ruban LED ne fonctionne pas, essayez d'abord de remplacer la pile. Si le problème persiste, contactez le vendeur.
- 8.Tenez la télécommande éloignée des enfants — éloignez-la vraiment !** En cas d'ingestion accidentelle de la pile, consultez immédiatement un médecin.



1



2



3



4



5



6



7



8



Modell : CR2025 3.V

9



10

