

# N621P383237N / N621P383238N

Product manual  
Gebrauchsanweisung  
Manuel du produit  
Manual del producto

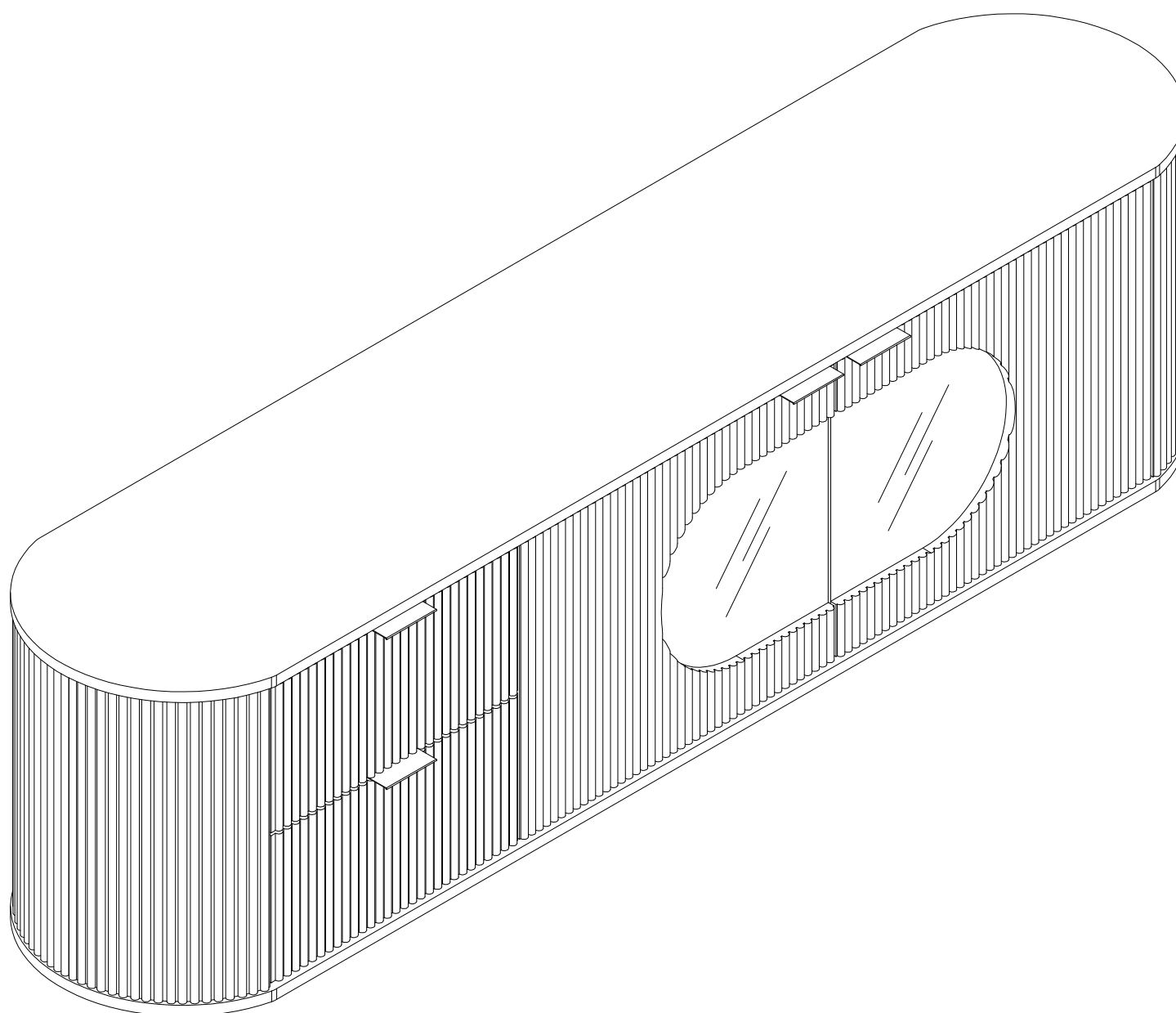

EN:Our product will be delivered to you in 2 packages.The delivery times of these 2 packages may differ, please be patient and thank you for your understanding

DE:Unsere produkte teilen sich in zwei pakete auf. Die lieferung der beiden pakete kann je nach jahreszeit variieren, so warten sie bitte geduldig und danken sie für ihr verständnis

FR:Notre produit vous sera livré en 2 paquets. Les délais de livraison de ces 2 colis peuvent différer, soyez patient et merci de votre compréhension

ES:Nuestro producto le será entregado en 2 paquetes. Los tiempos de entrega de estos 2 paquetes pueden variar, por favor sea paciente y gracias por su comprensión

IT:Il nostro prodotto sarà consegnato in 2 confezioni. I tempi di consegna di questi 2 pacchetti possono variare, per favore siate pazienti e vi ringrazio per la vostra comprensione

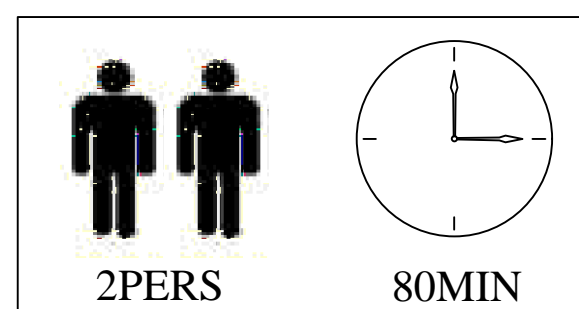



[DE]

**Warnung:** Lesen Sie die Anleitung vor dem Zusammenbau bitte vollständig durch. Überprüfen Sie, ob Sie alle auf den Seiten aufgeführten Komponenten und Werkzeuge haben.

**Warnung:** Legen Sie alle Teile auf eine ebene Fläche. Legen Sie eine weiche Decke oder Ähnliches darunter, um sie vor Kratzern oder Flecken zu schützen. Vermeiden Sie es, Komponenten über den Boden zu ziehen oder zu schieben.

**Warnung:** Überprüfen Sie regelmäßig alle Beschläge und Befestigungen, um sicherzustellen, dass sie sicher sind und um Unfälle zu vermeiden. Wenn Teile fehlen, kaputt, beschädigt oder abgenutzt sind, verwenden Sie das Produkt nicht weiter, bis es mit vom Hersteller autorisierten Teilen repariert wurde.

**Warnung:** Lassen Sie Kinder nicht auf die Möbel klettern, da dies zum Umkippen und zu schweren Verletzungen führen kann. Bauen Sie die Möbel außerhalb der Reichweite von Kindern zusammen.

**Warnung:** Stellen Sie die Möbel nicht in die Nähe von Feuerquellen oder heißen Gegenständen, um Brandgefahr zu vermeiden.

**Warnung:** Reinigen Sie die Möbel mit einem feuchten Tuch oder Alkohol. Verwenden Sie keine Reinigungsmittel mit ätzenden Chemikalien.

[EN]

**Warning:** Please read instructions fully before starting assembly. Check you have all the components and tools listed on pages.

**Warning:** Please place all parts on a flat surface. Place a soft blanket or similar underneath to protect against scratches or stains. Avoid dragging or sliding components across the floor.

**Warning:** Regularly check all fittings and fastenings to ensure they are secure and to prevent accidents. If any parts are missing, broken, damaged, or worn, discontinue use of the product until repairs have been made using factory authorized parts.

**Warning:** Do not allow children to climb on the furniture as this may result in tipping and serious personal injury. Assemble the furniture away from the reach of children.

**Warning:** Do not place furniture close to fire sources or high-temperature objects to avoid the risk of fire.

**Warning:** Clean furniture with a damp cloth or alcohol, avoid using cleaning agents containing corrosive chemicals.

[FR]

**Avertissement :** Veuillez lire entièrement les instructions avant de commencer l'assemblage. Vérifiez que vous disposez de tous les composants et outils répertoriés sur les pages.

**Avertissement :** Veuillez placer toutes les pièces sur une surface plane. Placez une couverture douce ou similaire en dessous pour les protéger des rayures ou des taches. Évitez de faire glisser les composants sur le sol.

**Avertissement :** Vérifiez régulièrement tous les raccords et fixations pour vous assurer qu'ils sont bien fixés et pour éviter les accidents. Si des pièces manquent, sont cassées, endommagées ou usées, cessez d'utiliser le produit jusqu'à ce que des réparations aient été effectuées à l'aide de pièces autorisées par l'usine.

**Avertissement :** Ne laissez pas les enfants grimper sur les meubles car cela pourrait entraîner un basculement et des blessures graves. Assemblez les meubles hors de portée des enfants.

**Avertissement :** Ne placez pas les meubles à proximité de sources de feu ou d'objets à haute température pour éviter tout risque d'incendie.

**Avertissement :** Nettoyez les meubles avec un chiffon humide ou de l'alcool, évitez d'utiliser des produits de nettoyage contenant des produits chimiques corrosifs.



[IT]

**Attenzione:** leggere attentamente le istruzioni prima di iniziare il montaggio. Verificare di avere tutti i componenti e gli strumenti elencati nelle pagine.

**Attenzione:** posizionare tutte le parti su una superficie piana. Posizionare una coperta morbida o simile sotto per proteggere da graffi o macchie. Evitare di trascinare o far scivolare i componenti sul pavimento.

**Attenzione:** controllare regolarmente tutti i raccordi e i dispositivi di fissaggio per assicurarsi che siano sicuri e per prevenire incidenti. Se alcune parti sono mancanti, rotte, danneggiate o usurate, interrompere l'uso del prodotto fino a quando non siano state eseguite le riparazioni utilizzando parti autorizzate dalla fabbrica.

**Attenzione:** non consentire ai bambini di arrampicarsi sui mobili poiché ciò potrebbe causare ribaltamenti e gravi lesioni personali. Montare i mobili lontano dalla portata dei bambini.

**Attenzione:** non posizionare i mobili vicino a fonti di fuoco o oggetti ad alta temperatura per evitare il rischio di incendio.

**Attenzione:** pulire i mobili con un panno umido o alcol, evitare di utilizzare detergenti contenenti sostanze chimiche corrosive.

[ES]

**Advertencia:** Lea las instrucciones completamente antes de comenzar el montaje. Compruebe que tiene todos los componentes y herramientas que se enumeran en las páginas.

**Advertencia:** Coloque todas las piezas sobre una superficie plana. Coloque una manta suave o algo similar debajo para protegerlas de rayones o manchas. Evite arrastrar o deslizar los componentes por el piso.

**Advertencia:** Verifique regularmente todos los accesorios y fijaciones para asegurarse de que estén seguros y evitar accidentes. Si falta alguna pieza, está rota, dañada o desgastada, deje de usar el producto hasta que se hayan realizado las reparaciones con piezas autorizadas de fábrica.

**Advertencia:** No permita que los niños se suban a los muebles, ya que esto puede provocar que se vuelquen y lesiones personales graves. Monte los muebles fuera del alcance de los niños.

**Advertencia:** No coloque los muebles cerca de fuentes de fuego u objetos de alta temperatura para evitar el riesgo de incendio.

**Advertencia:** Limpie los muebles con un paño húmedo o alcohol, evite usar agentes de limpieza que contengan químicos corrosivos.

Importeur	Decobus Handel GmbH
Adresse	Innungsstraße 9,21244 Buchholz,Deutschland
URL	<a href="https://www.decobusgroup.de">https://www.decobusgroup.de</a>
Hersteller	ZHANG ZHOU RI SHENG FURNITURE CO., LTD
Adresse	NO.238NATIONAL ROAD 319,XIANGCHENG DISTRICT, ZHANGZHOU,FUJIAN PROVINCE
Email/URL	Even@zzrsfurniture.com
Partienummer	N621P383237N / N621P383238N
Herge stellt in	CHINA
	Decobus Handel GmbH Innungsstraße 9,21244 Buchholz,Deutschland <a href="https://www.decobusgroup.de">https://www.decobusgroup.de</a>

# Exploded View

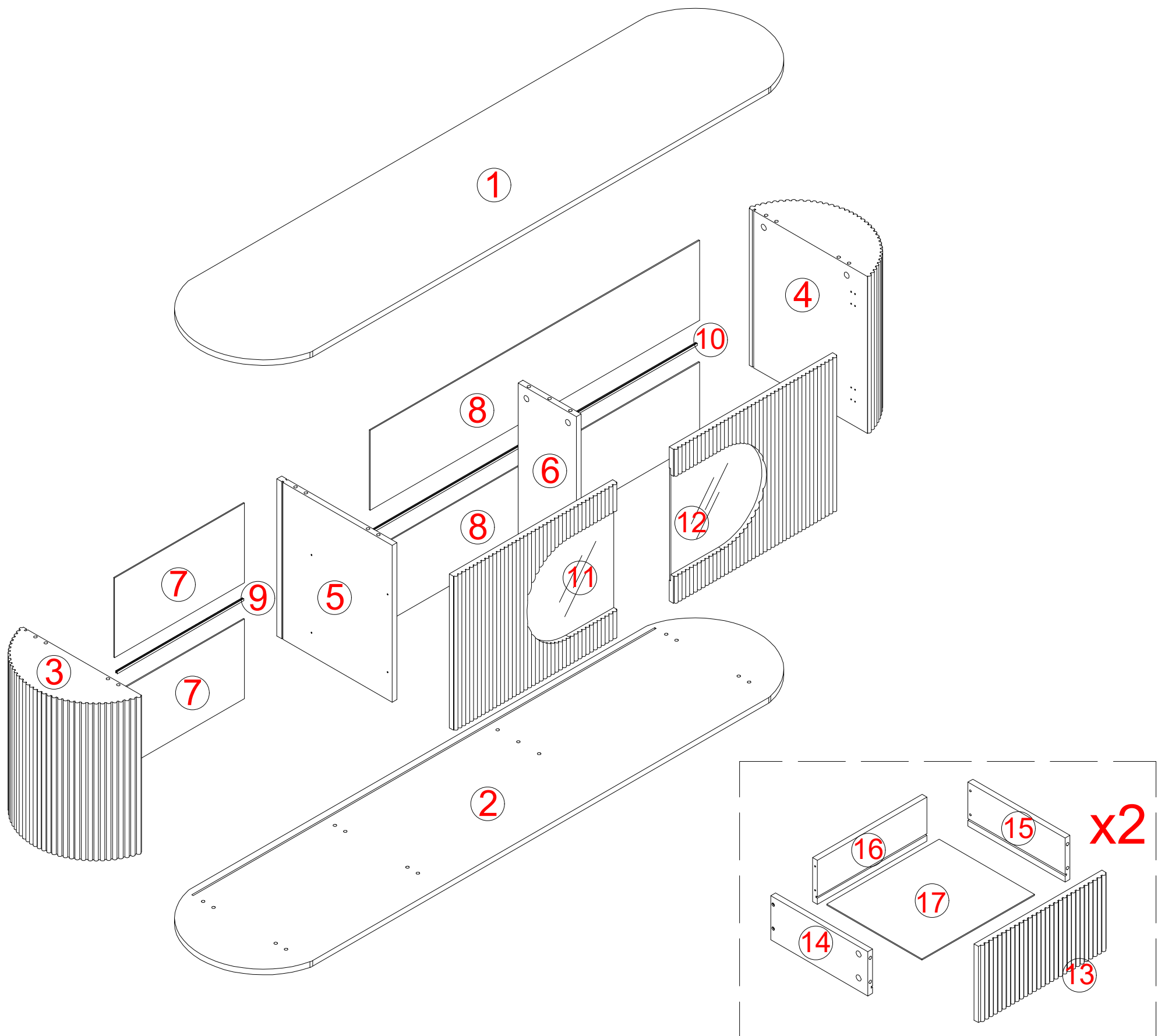

# N621P383237N

1

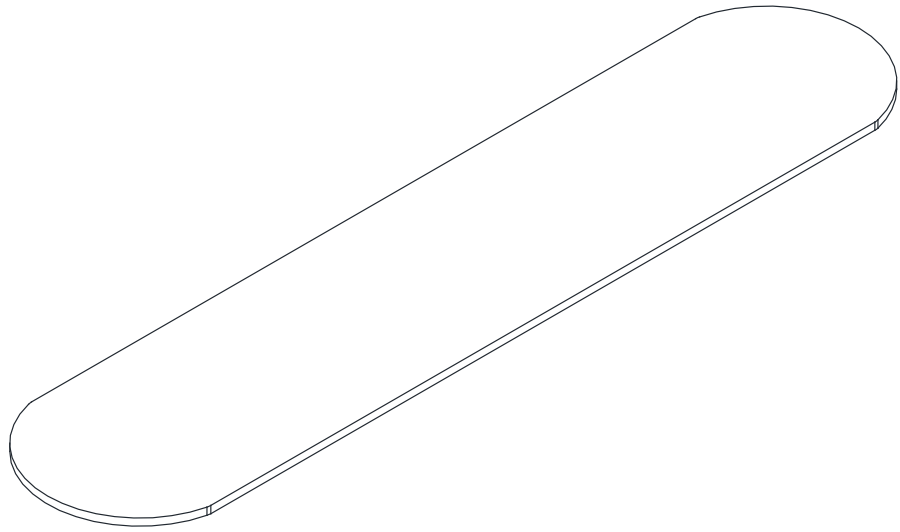

1PC

2

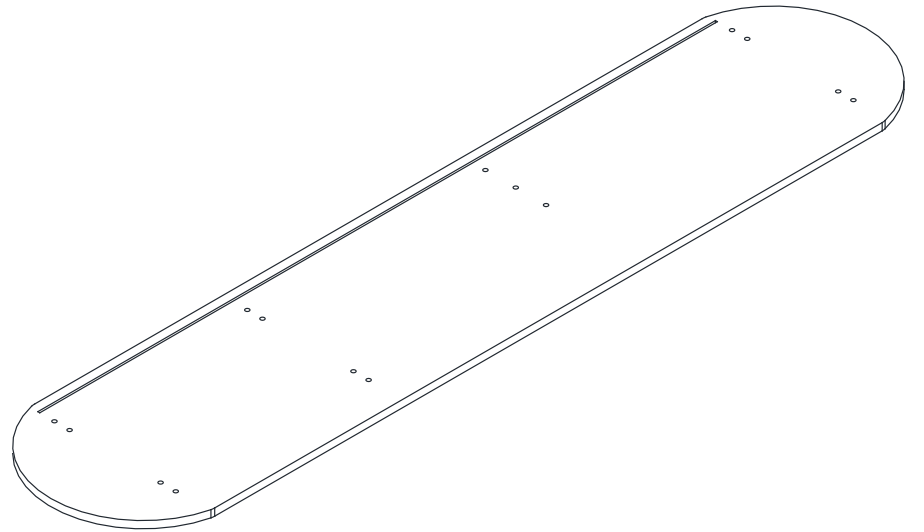

1PC

5

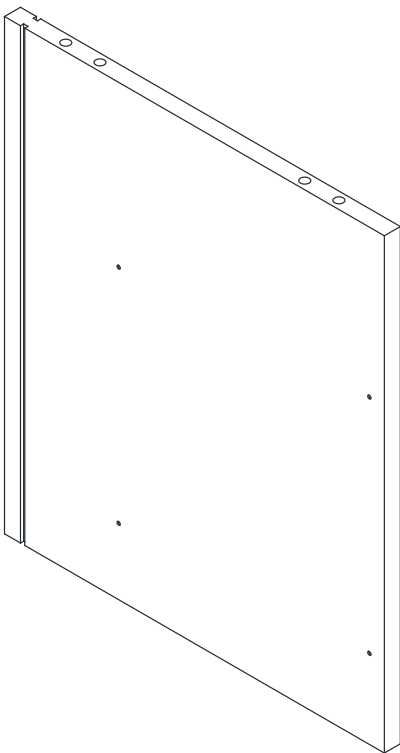

1PC

7

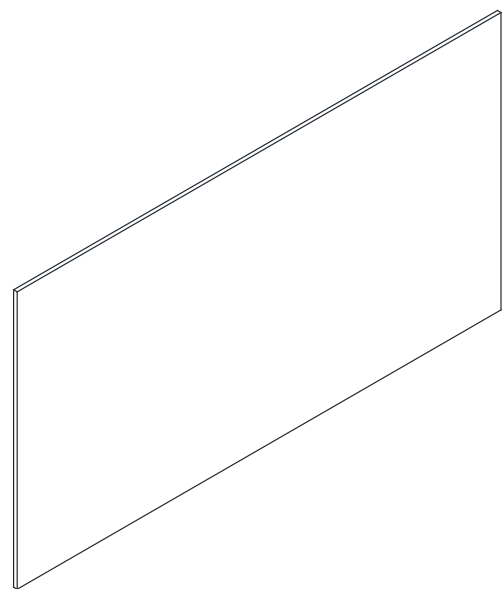

2PCS

8

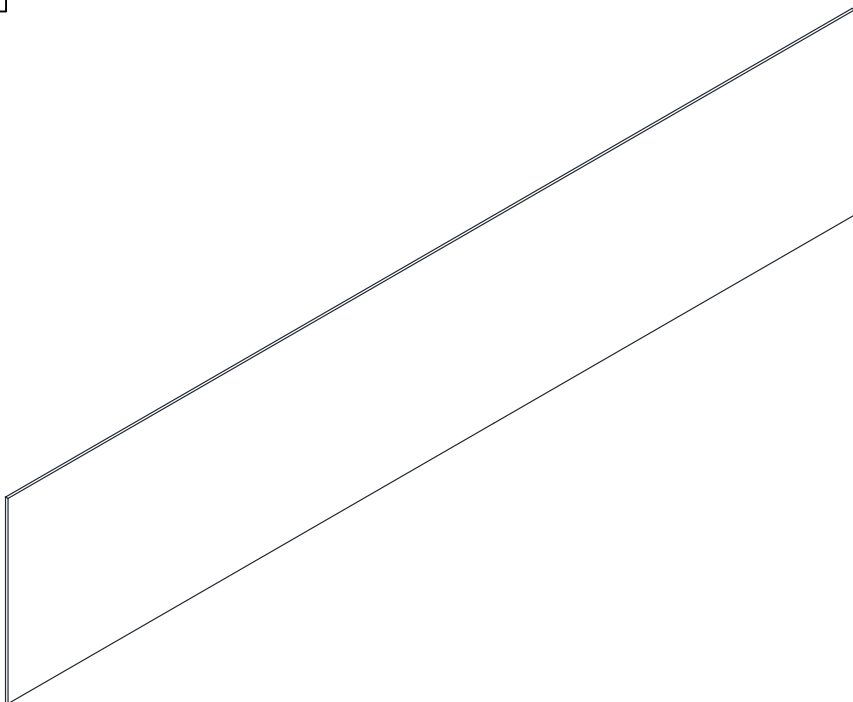

2PCS

9

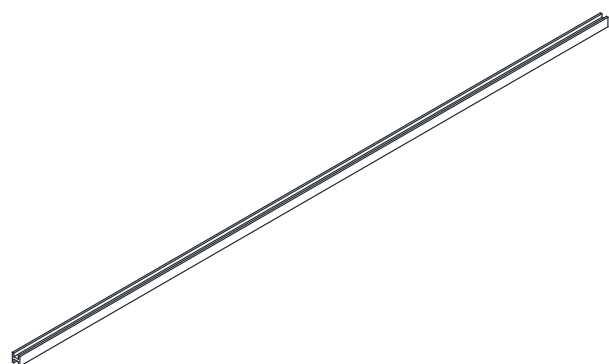

1PC

# N621P383237N

10

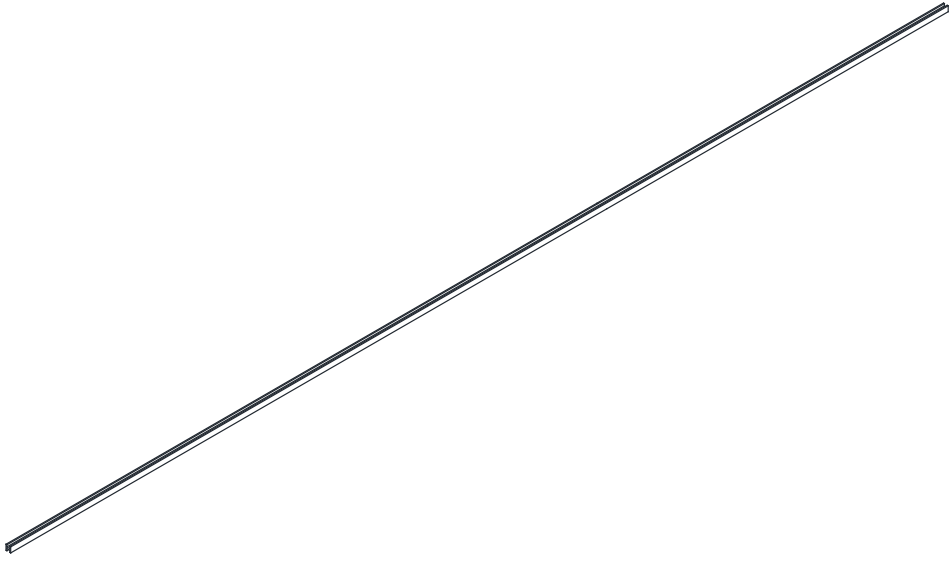

1PC

13

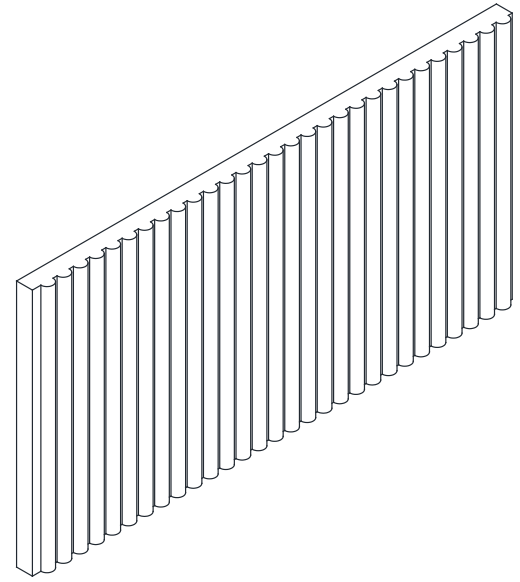

2PCS

14

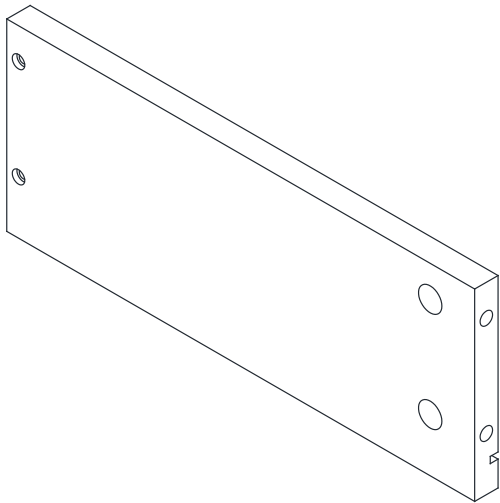

2PCS

15

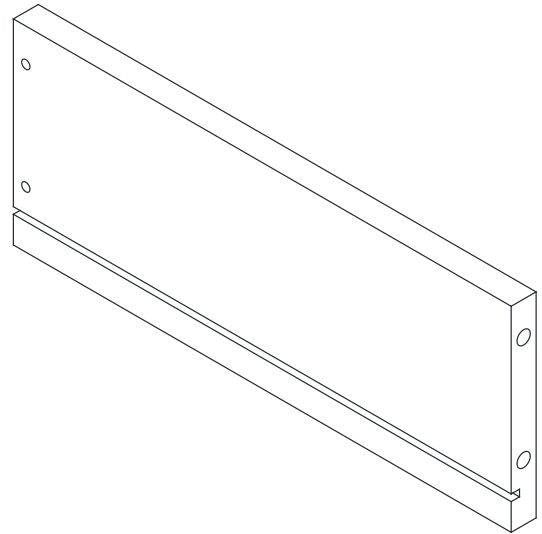

2PCS

16

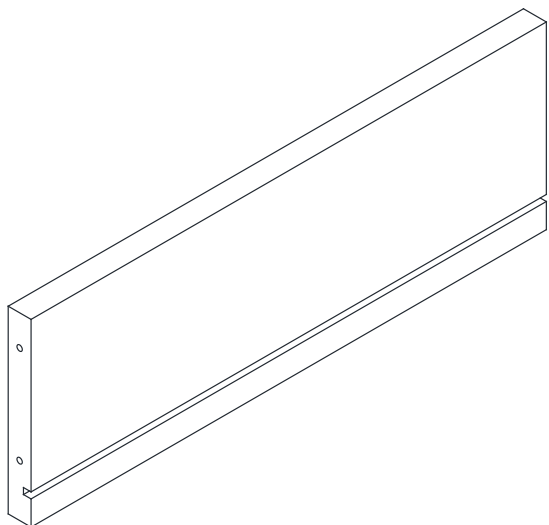

2PCS

17

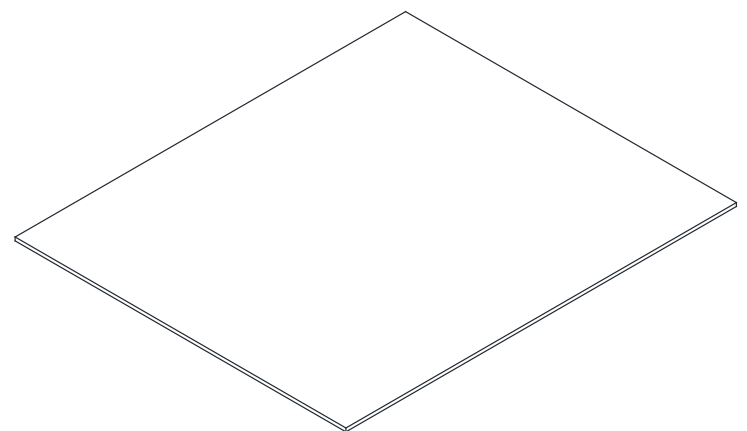

2PCS

# N621P383238N

3

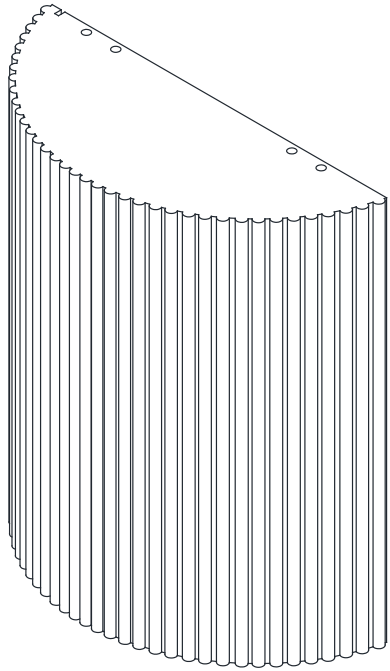

1PC

4

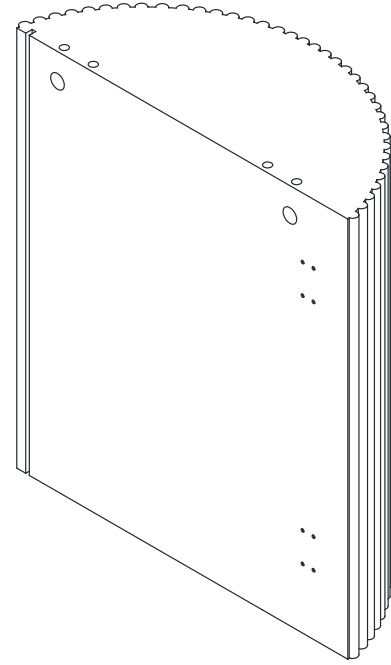

1PC

6

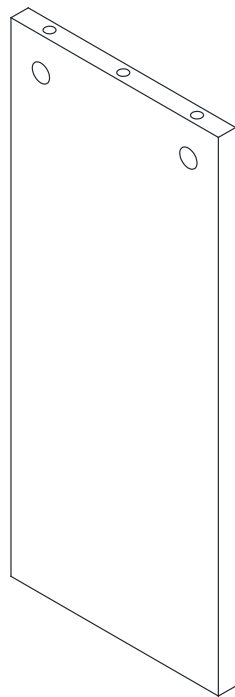

1PC

11

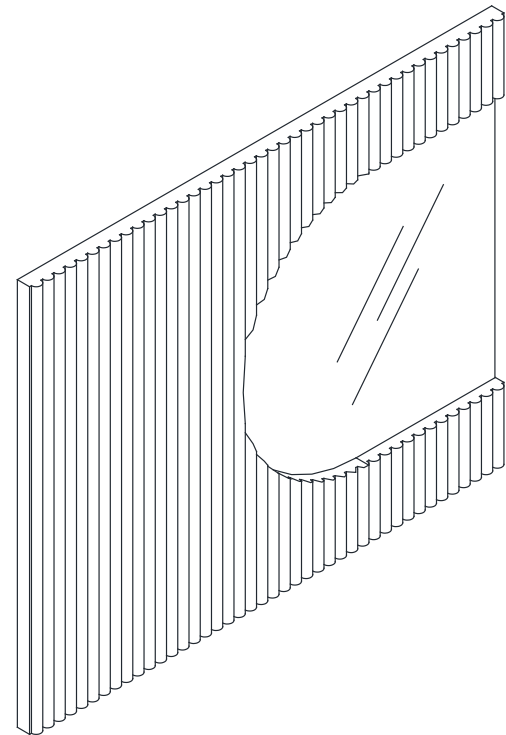

1PC

12

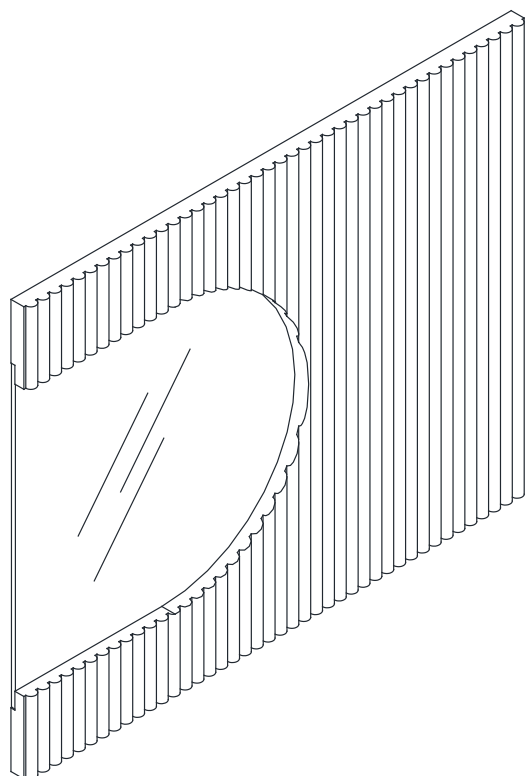

1PC

# N621P383238N

# Hardware List

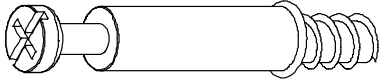
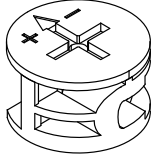
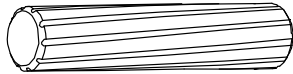
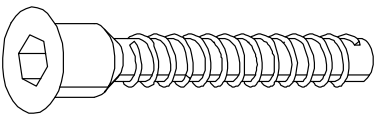
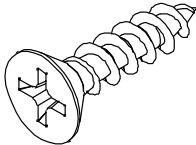
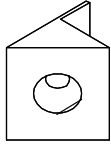
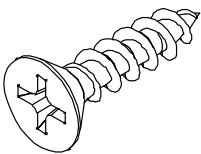
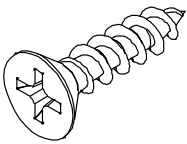
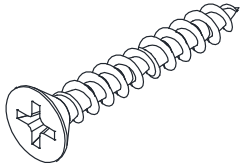
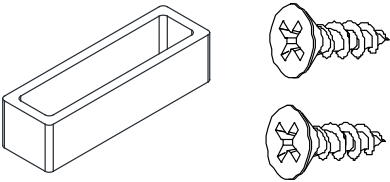
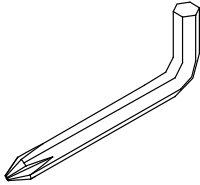
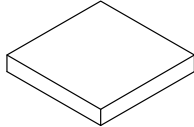
Minifix Bolt M6x35		Minifix Cam $\varnothing$ 15x12		Dowels $\varnothing$ 8x30	
					
<b>A</b>	16 PCS	<b>B</b>	16 PCS	<b>C</b>	14 PCS
screw M7x38		screw M3x14		Back panel holder	
					
<b>D</b>	8 PCS	<b>E</b>	28 PCS	<b>F</b>	20 PCS
screw M4x14		screw M3x12		screw M4x35	
					
<b>G</b>	24 PCS	<b>H</b>	16 PCS	<b>I</b>	8 PCS
Plastic dooc stop		Wrench		Wool felt cushion	
					
<b>J</b>	1 PC	<b>K</b>	1 PC	<b>L</b>	8 PCS

Tools Required (Hammers are not included)

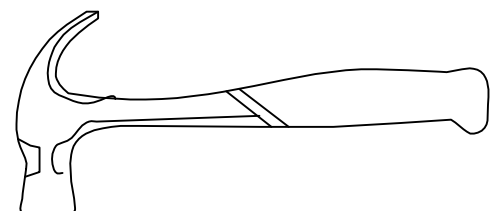
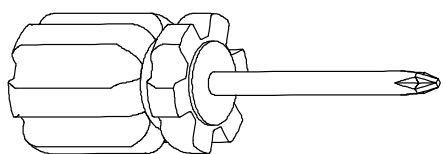

# N621P383238N

# Hardware List

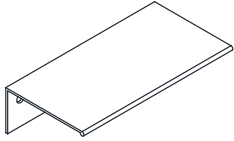
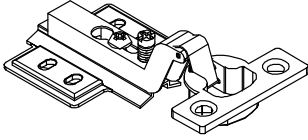
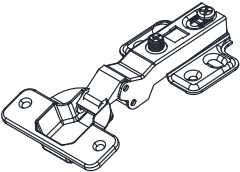
Hold hands		Hinge		Hinge	
					
M	4 PCS	N	2 PCS	O	2 PCS

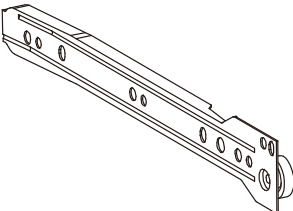
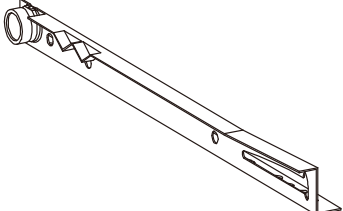
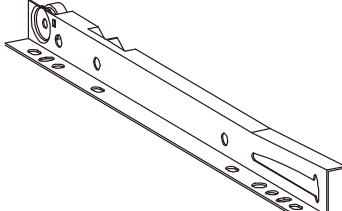
drawer slide rail		drawer slide rail		drawer slide rail	
					
CL	2 PCS	DL	2 PCS	DR	2 PCS

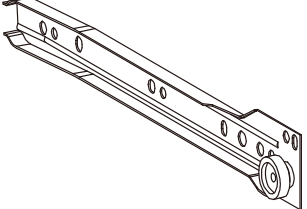
drawer slide rail	
	
CR	2 PCS

Tools Required (Hammers are not included)

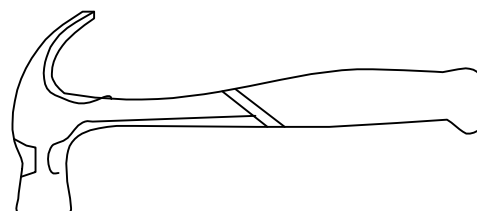
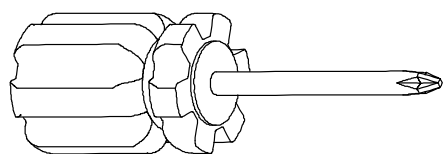

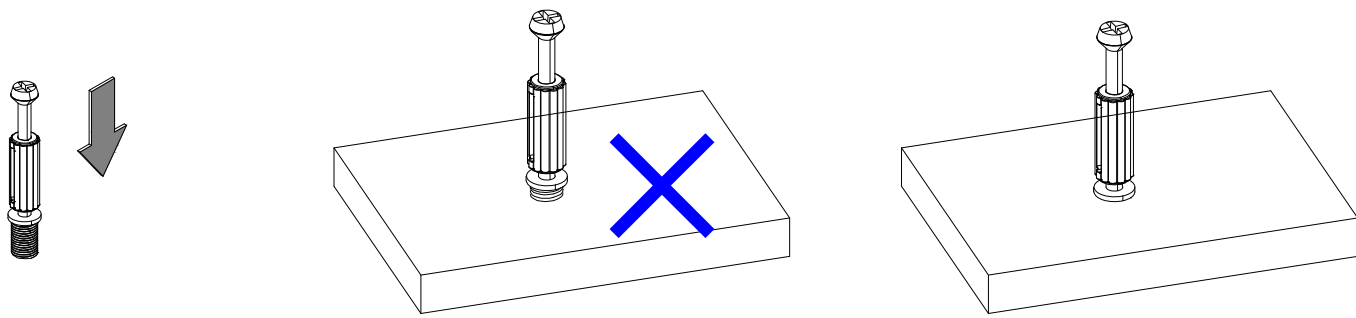

EN QUICKFIT:Tighten quickfit until shoulder is flush with panel.Do not overtighten or undertighten.

FR RACCORD RAPIDE:Faites serrer le raccord rapide jusqu'a ce que l'epaulement soit parfaitement encastre dans le panneau.II ne faut ni trop serrer ni insuffisamment serrer. ESQUICKFIT:Apriete quickfit hasta que el hombro se descargue con el panel.NO lo sobreapriete ni lo apriete poco.

DE QUICKFIT:Ziehen Sie den Quickfit fest,bis die Schulter mit der Platte bundig ist. Bitte nicht zu fest oder zu schwach anziehen.

IT\_MONTAGGIO RAPIDO:Stringere il montaggio rapido fino a quando la spalla e a filo con il pannello,non stringere troppo o troppo poco.

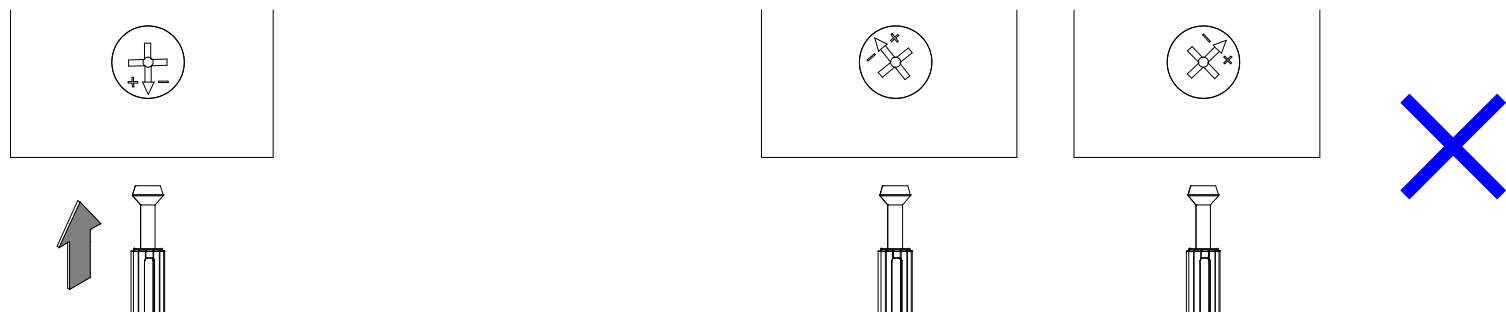

EN CAM LOCK:When fitting cam lock,ensure starting position is correct before youinsert connecting quickfit.  
FR SERRURE BATTEUSE:Avant d'insérer la serrure batteuse,veillez a la bonne orientation avant d'insérer le raccord rapide.

ES CIERRE DE LA CAMARA:Cuando instale el cierre de la camara,asegurese de que la posicion de inicio es correcta antes de que inserte el quickfit conector.

DE\_CAM-LOCK:Achten Sie bei der Montage des Cam-Locks auf die richtige Ausgangsposition,bevor Sie den Quickfit einsetzen.

IT BLOCCAGGIO A CAMMA:Quando si monta il bloccaggio a camma,assicurarsi che la posizione iniziale sia corretta prima di inserire il montaggio rapido di collegamento

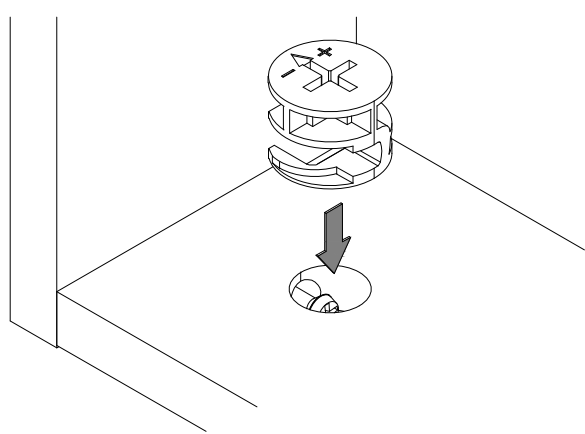

EN Quickfit head should be in the centre of the cam lock when the two panels are joined.

Cam lock should be inserted before quickfit.

FR\_Lorsque les deux panneaux sont assembles,la tete du raccord rapide doit reposer au centre de la serrure batteuse. Il faut inserer la serrure batteuse avant le raccord rapide.

ES\_El cabezal del quickfit debe estar en el centro del cierre de la camara cuando se unan los dos paneles.

Se debe insertar el cierre de la camara antes que el quickfit.

DEDer Quickfit-Kopf sollte sich in der Mitte des Cam-Locks befinden,wenn die beiden Platten zusammengefügt sind.

Der Cam-Lock sollte vor dem Quickfit eingesetzt werden.

IT\_La testa del montaggio rapido deve trovarsi al centro del bloccaggio a camma quando i due pannelli sono uniti.

Il Bloccaggio a Camma deve essere inserito prima del montaggio rapido.

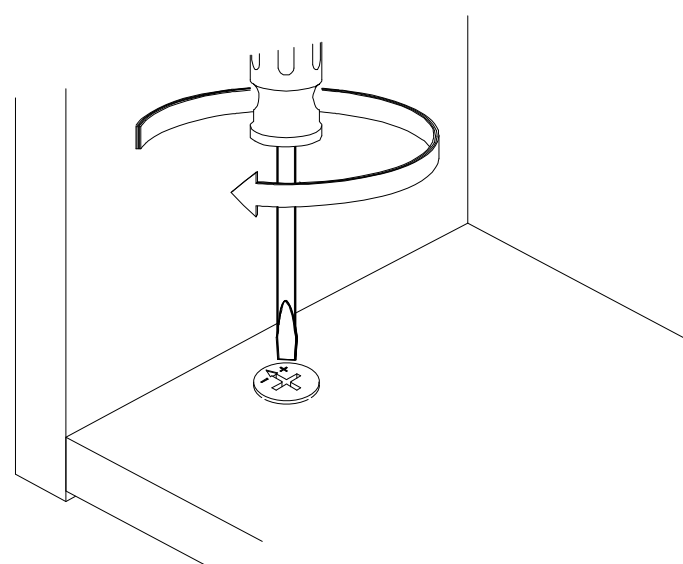

EN Turn cam lock clockwise to tighten.

FR Faites tourner la serrure batteuse dans le sens des aiguilles d'une montre pour la resserrer.

ES Gire el cierre de la camara en sentido horario para apretarlo. DE Drehen Sie den Cam-Lock im Uhrzeigersinn,um ihn festzuziehen.

ITRuotare il bloccaggio a camma in senso orario per stringere.

1

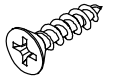
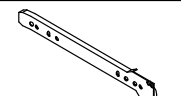
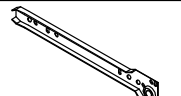
		
<b>H</b>	<b>CL</b>	<b>CR</b>
8 PCS	2 PCS	2 PCS

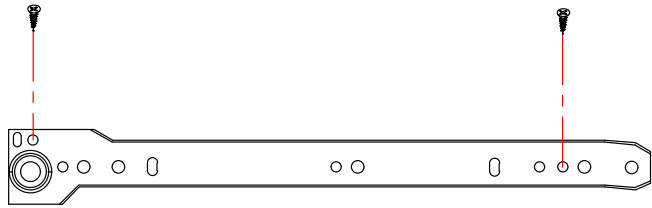

CL

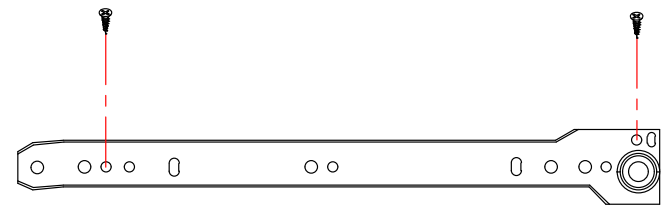

CR

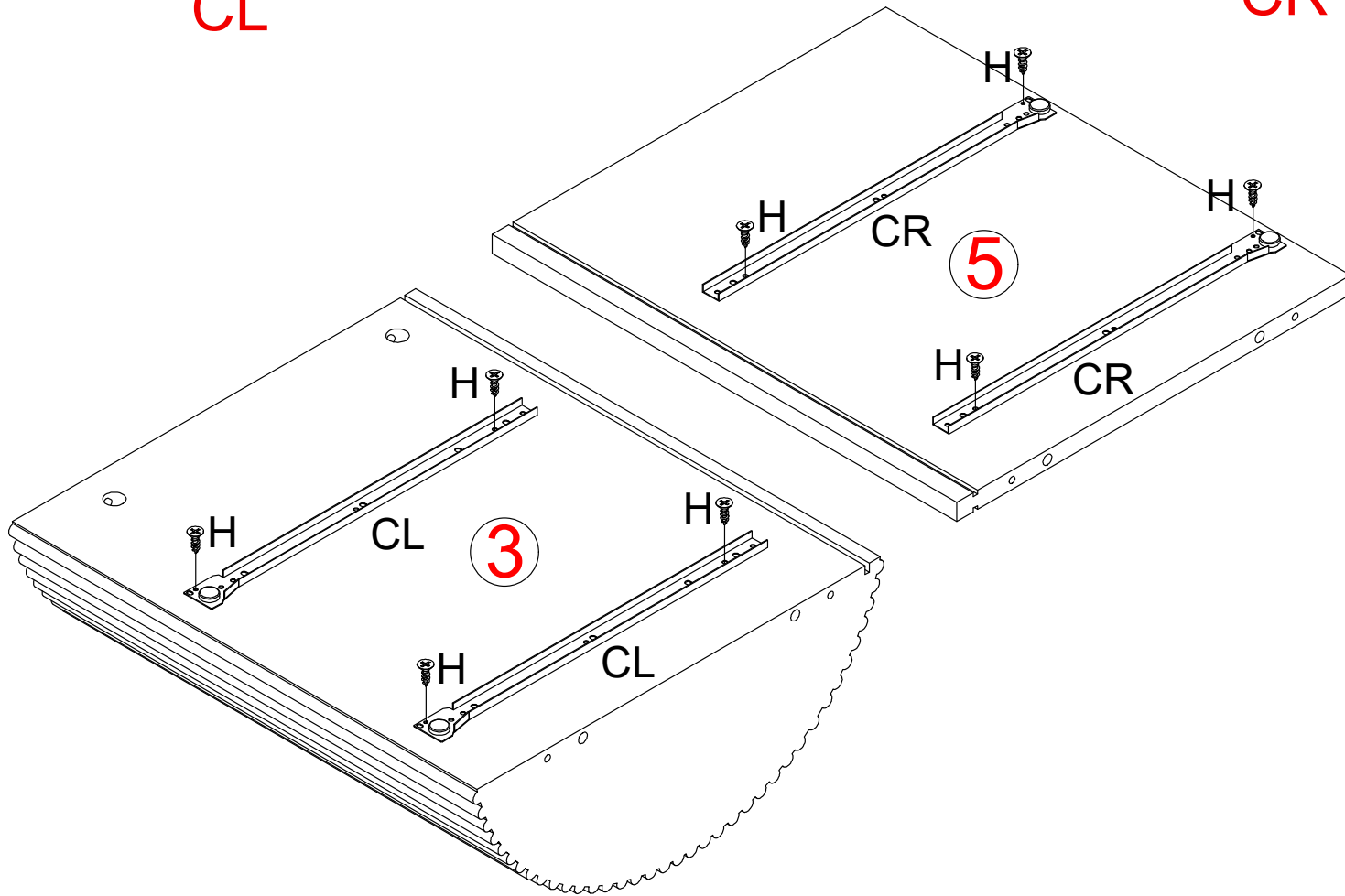

2

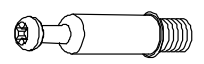
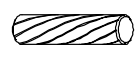
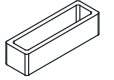
		
<b>A</b>	<b>C</b>	<b>J</b>
8 PCS	7 PCS	1 PC

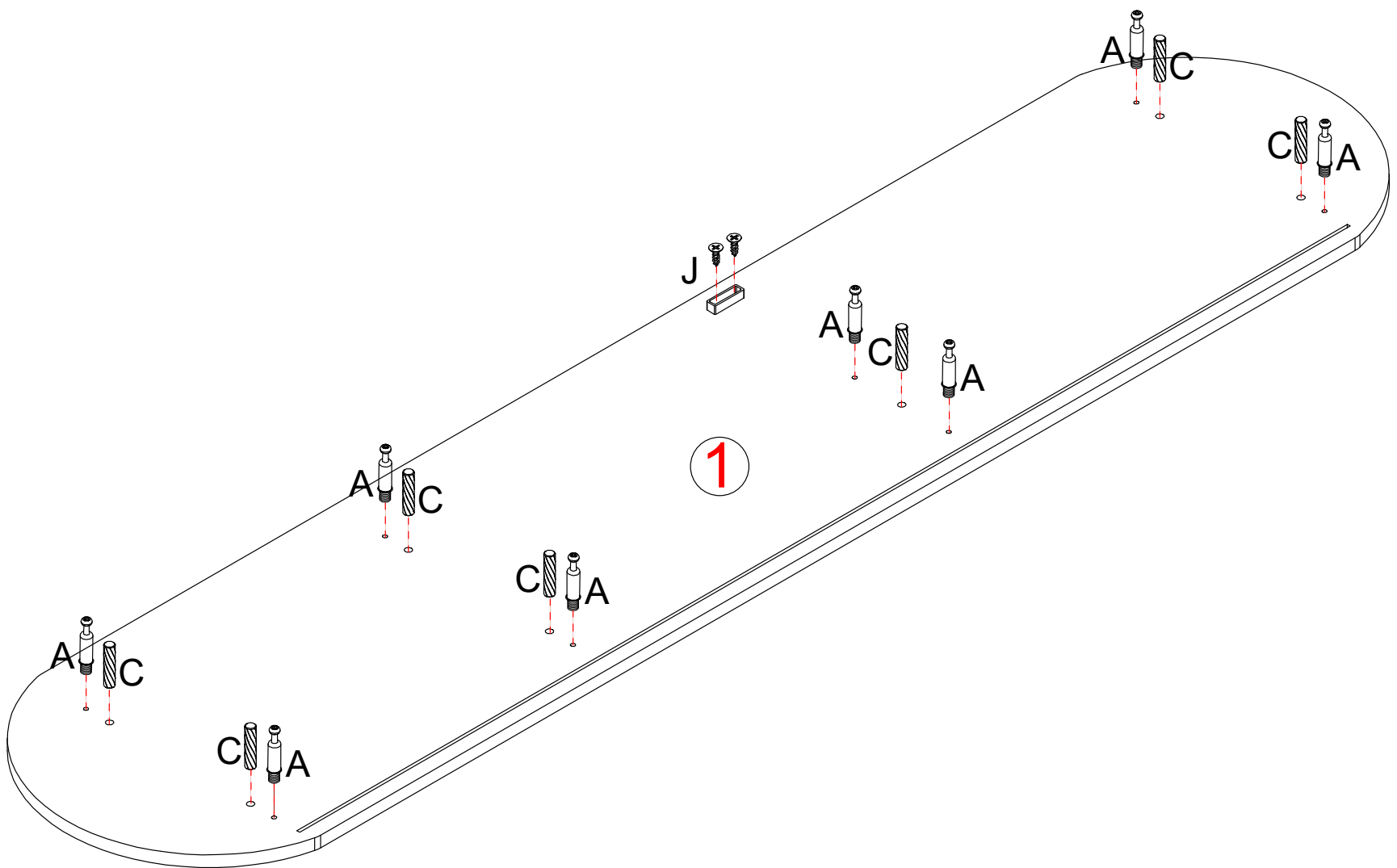

1

3



B

8 PCS

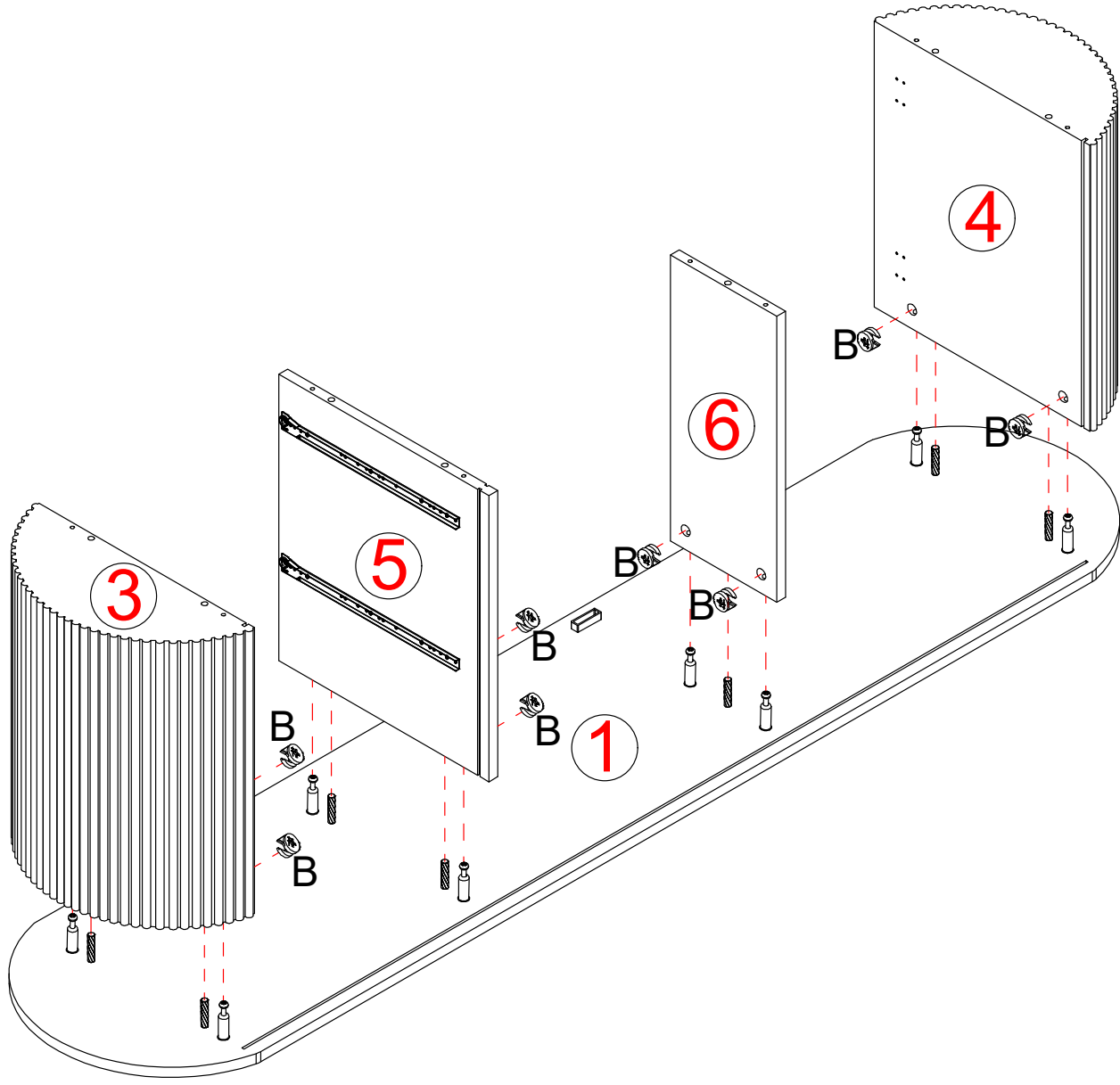

4

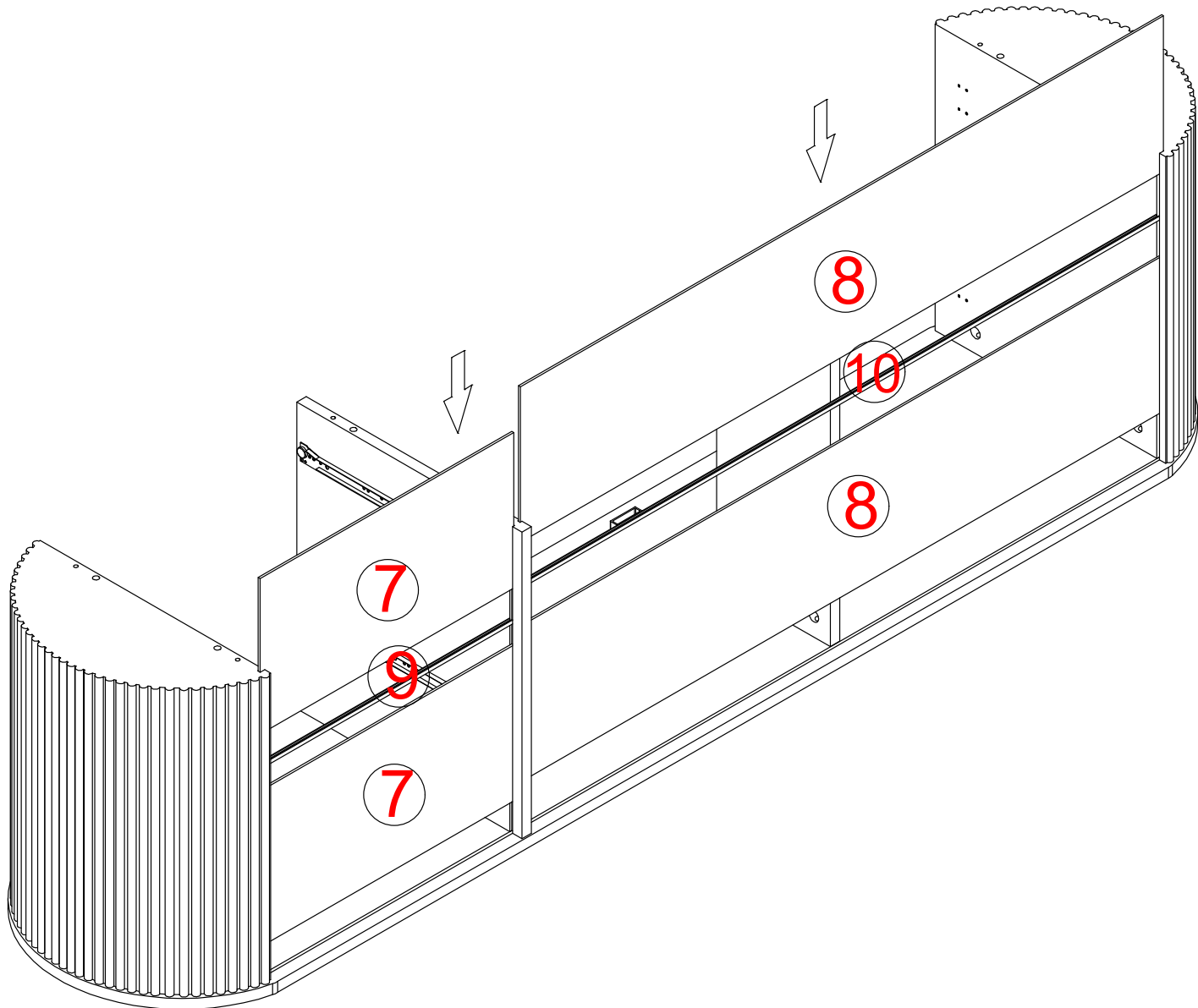

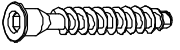

5

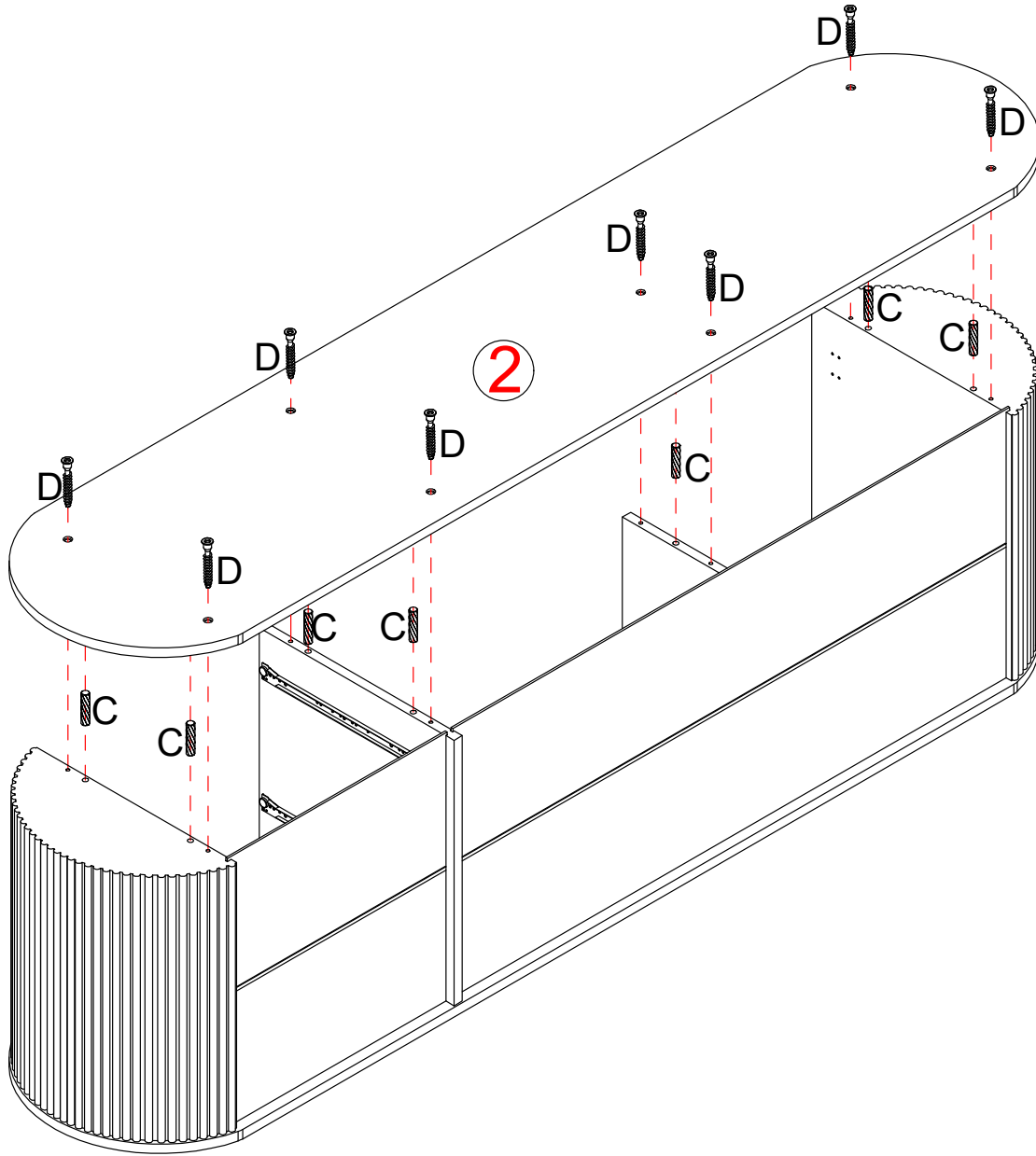
	
C 7 PCS	D 8 PCS



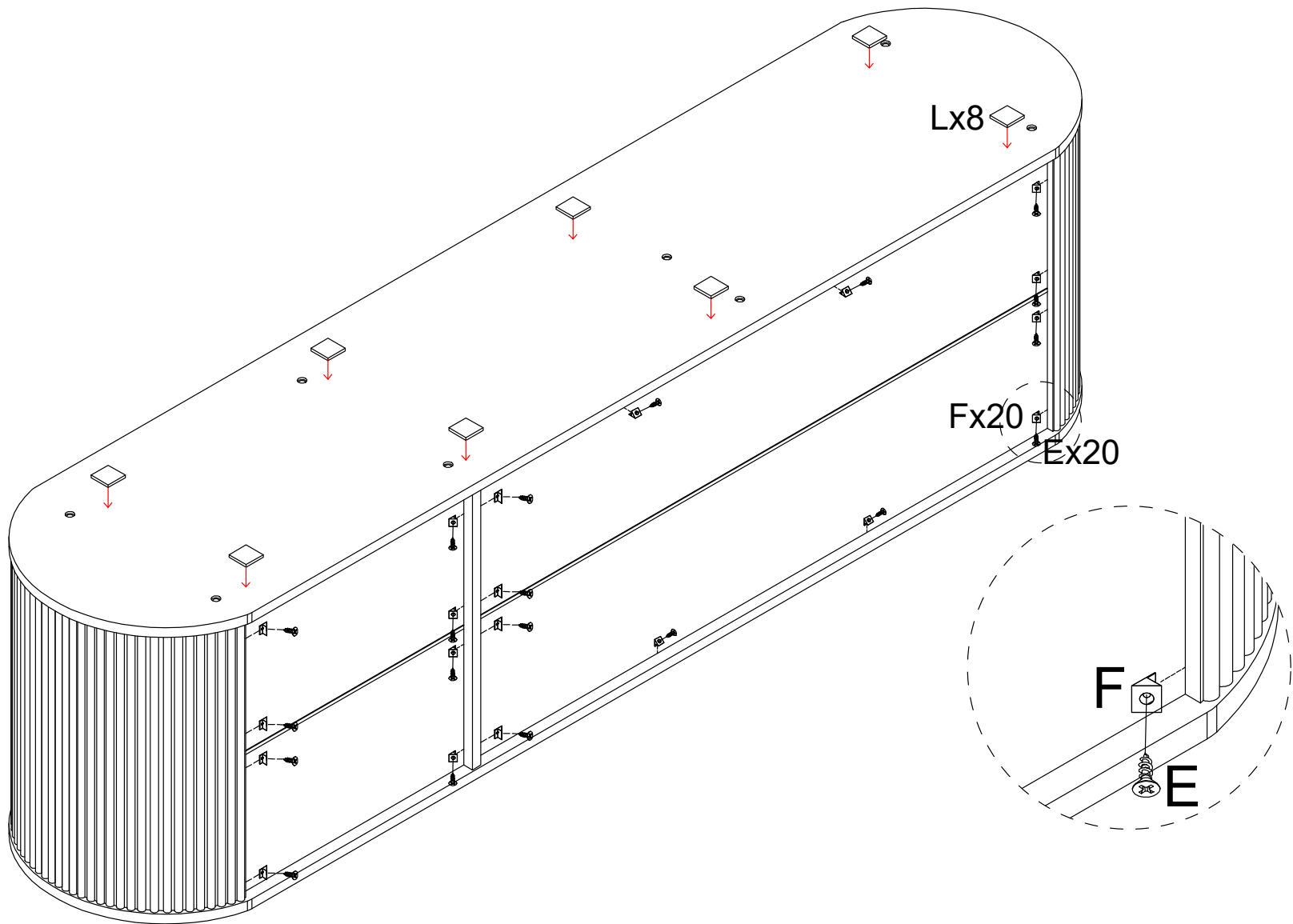

6

		
E 20 PCS	F 20 PCS	L 8 PCS

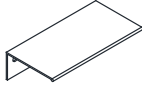
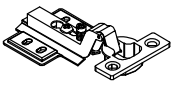
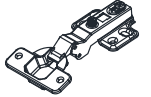

7

	<b>E</b> 4 PCS		<b>G</b> 8 PCS		<b>M</b> 2 PCS		<b>N</b> 2 PCS		<b>O</b> 2 PCS
---	----------------	---	----------------	--	----------------	--	----------------	--	----------------

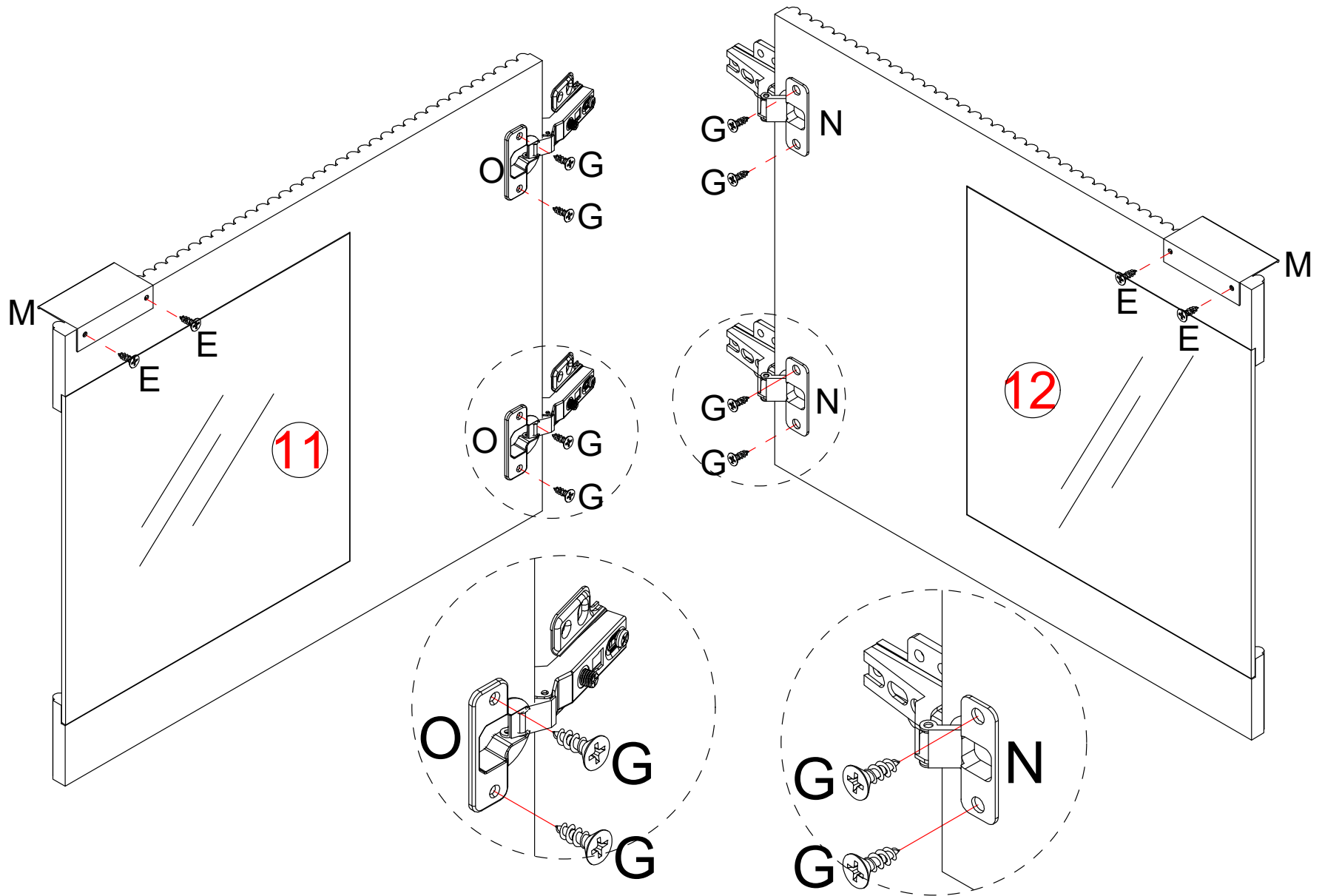

8

Note: It is forbidden to install the fixing hole screws first, otherwise it will lead to installation failure!

Remarque : Il est interdit d'installer d'abord les vis du trou de fixation, sinon cela entraînera un échec de l'installation !

Hinweis: Es ist verboten, zuerst die Befestigungslochschauben zu montieren, da dies sonst zu einem Installationsfehler führt!

	<b>G</b> 8 PCS
---	----------------

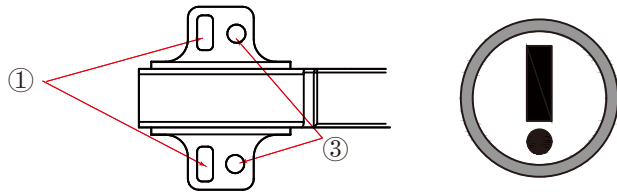

- ① Installez d'abord les vis du trou de réglage
- ② Mettez la porte dans la bonne position
- ③ Montieren Sie abschließend die Befestigungslochschauben

- ① Install the adjustment hole screws first
- ② Get the door in the right position
- ③ Finally, install the fixing hole screws

- ① Montieren Sie zuerst die Einstellochschauben
- ② Bringen Sie die Tür in die richtige Position
- ③ Enfin, installez les vis du trou de fixation

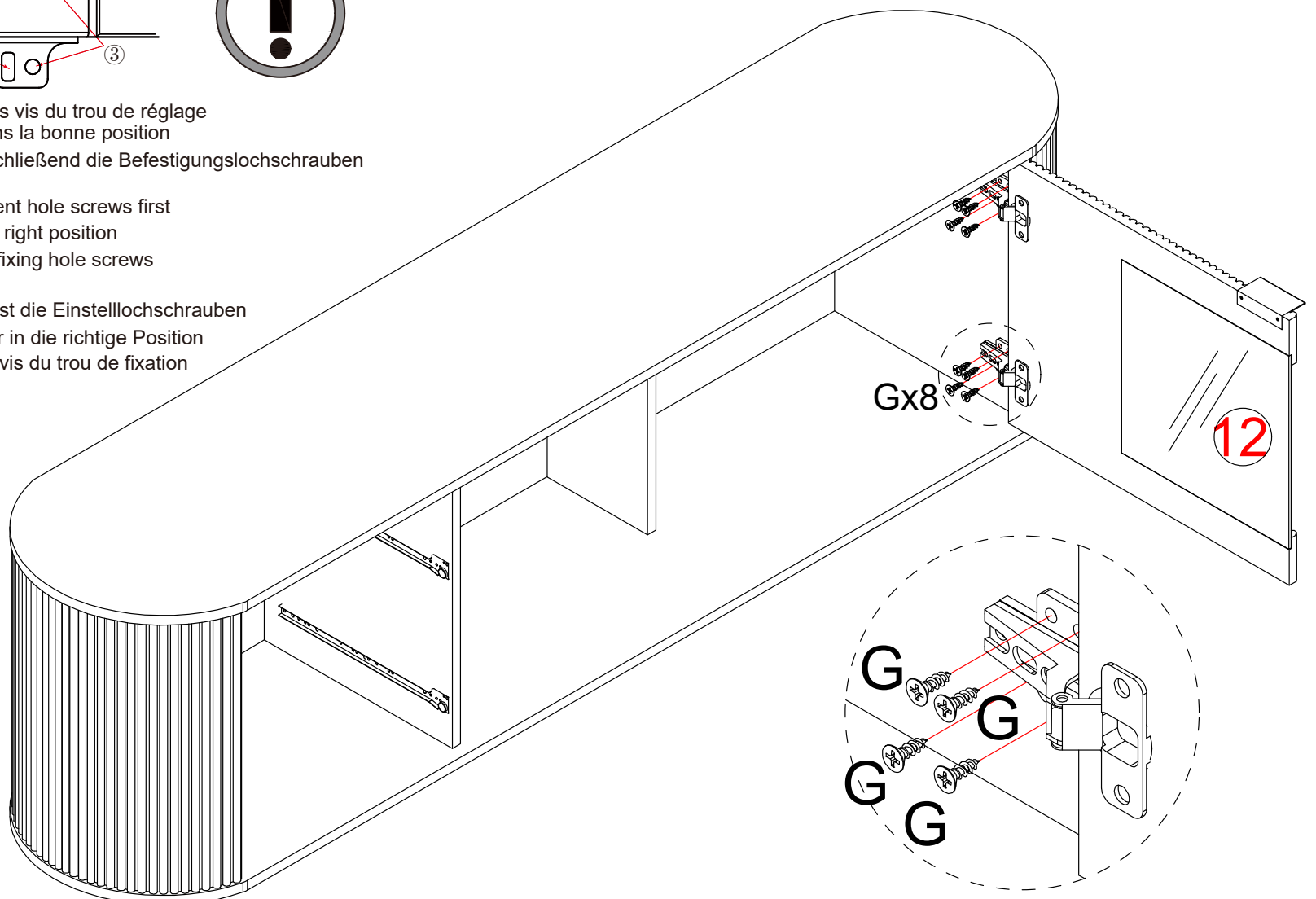

9

	
<b>G</b>	<b>8 PCS</b>

Note: It is forbidden to install the fixing hole screws first, otherwise it will lead to installation failure!

Remarque : Il est interdit d'installer d'abord les vis du trou de fixation, sinon cela entraînera un échec de l'installation !

Hinweis: Es ist verboten, zuerst die Befestigungslochschauben zu montieren, da dies sonst zu einem Installationsfehler führt!

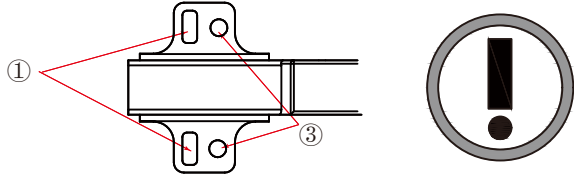

- ① Installez d'abord les vis du trou de réglage
- ② Mettez la porte dans la bonne position
- ③ Montieren Sie abschließend die Befestigungslochschauben

- ① Install the adjustment hole screws first
- ② Get the door in the right position
- ③ Finally, install the fixing hole screws

- ① Montieren Sie zuerst die Einstellochschauben
- ② Bringen Sie die Tür in die richtige Position
- ③ Enfin, installez les vis du trou de fixation

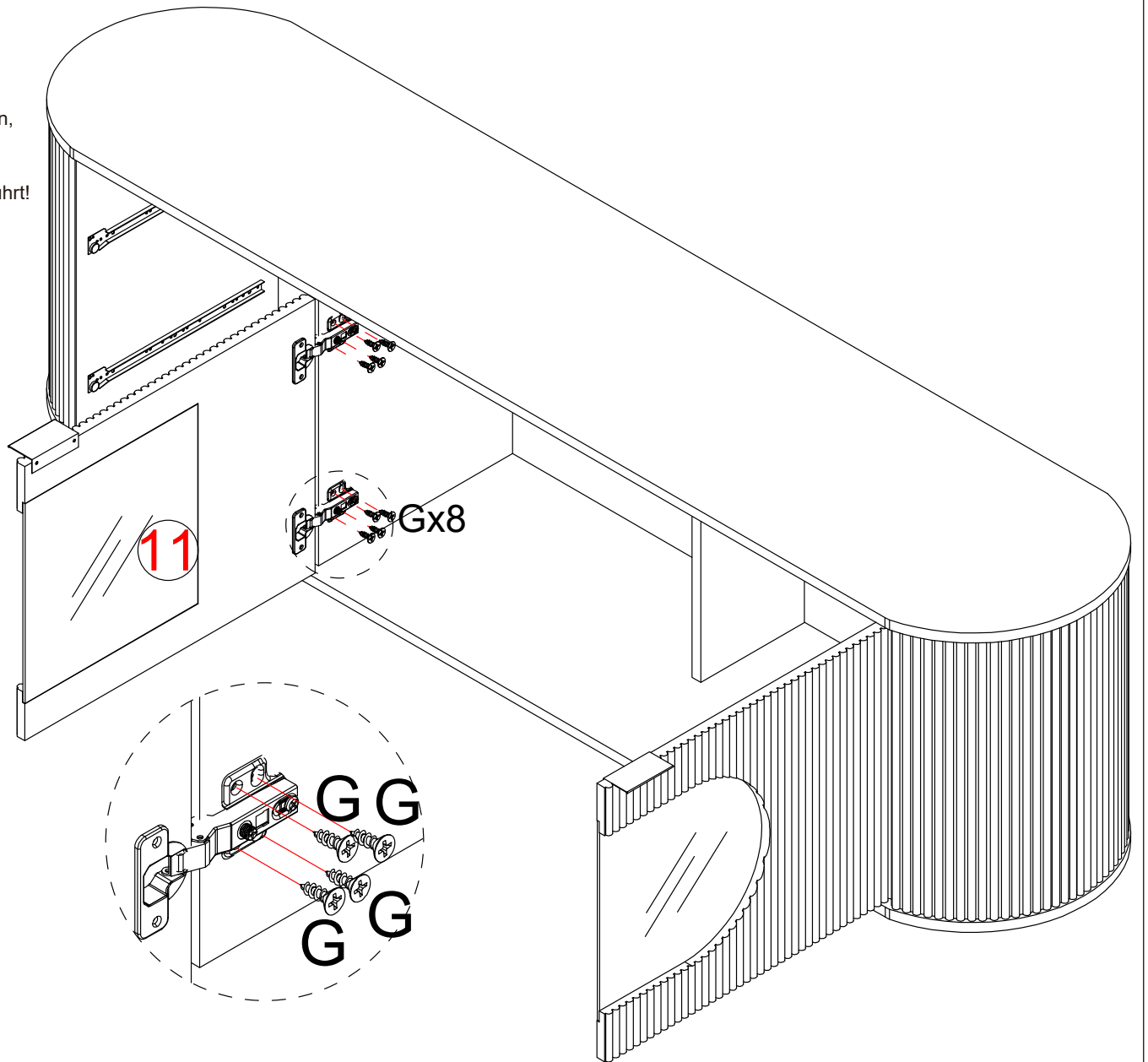

10

Please adjust the door panel gap according to the following diagram

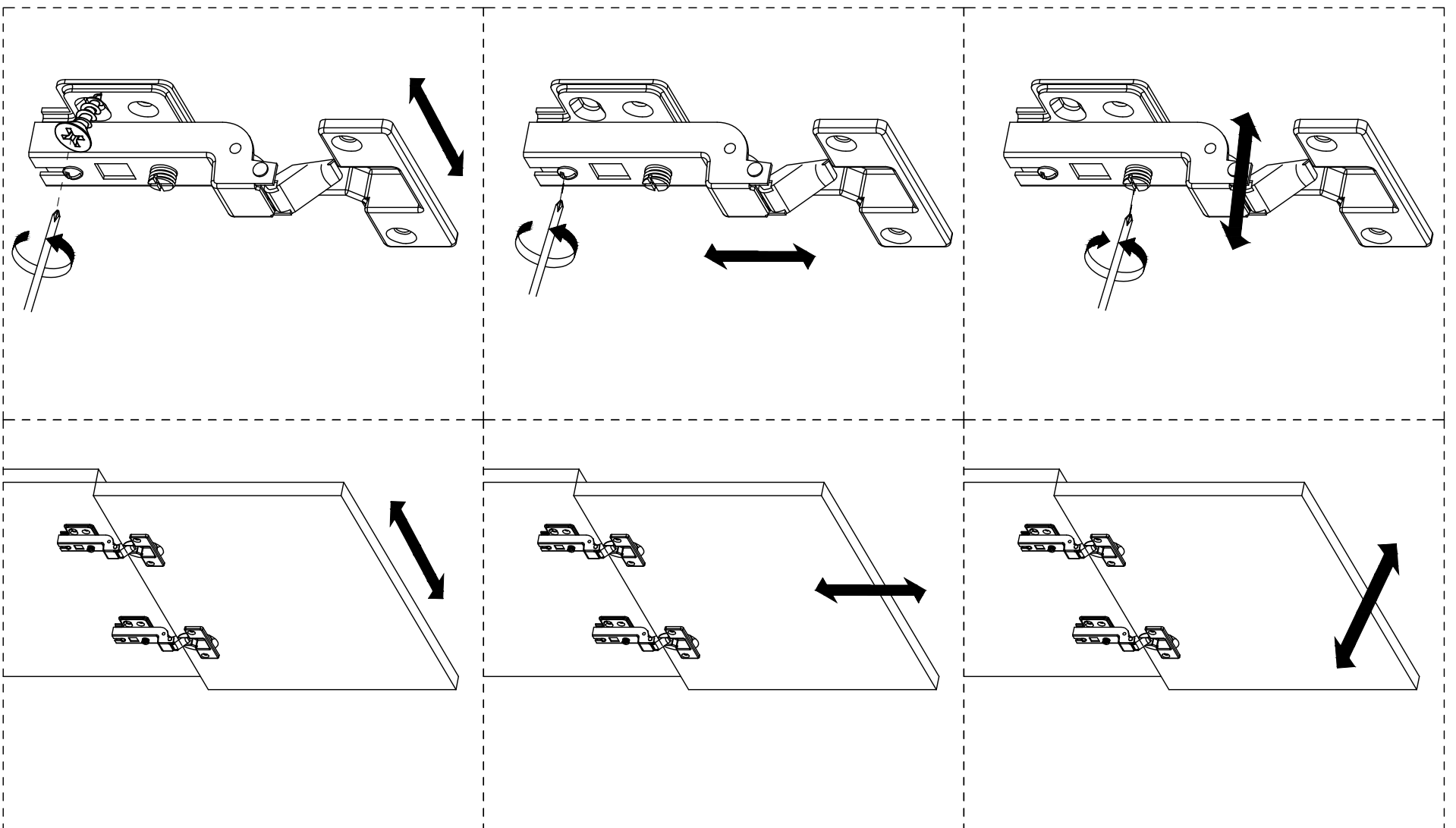

11

x2

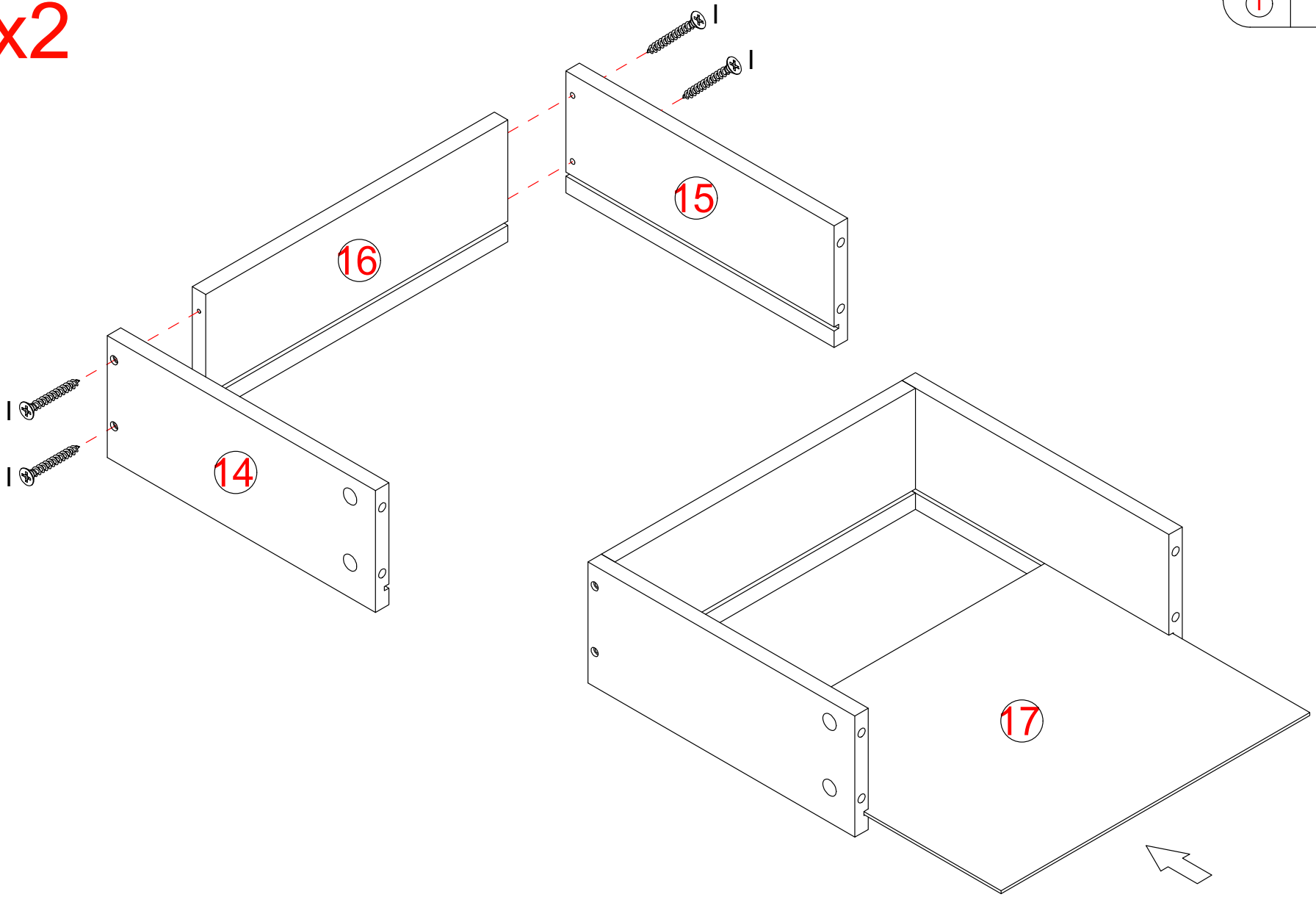
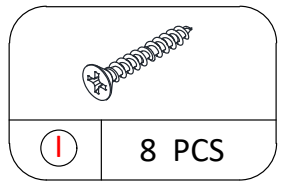

12

x2

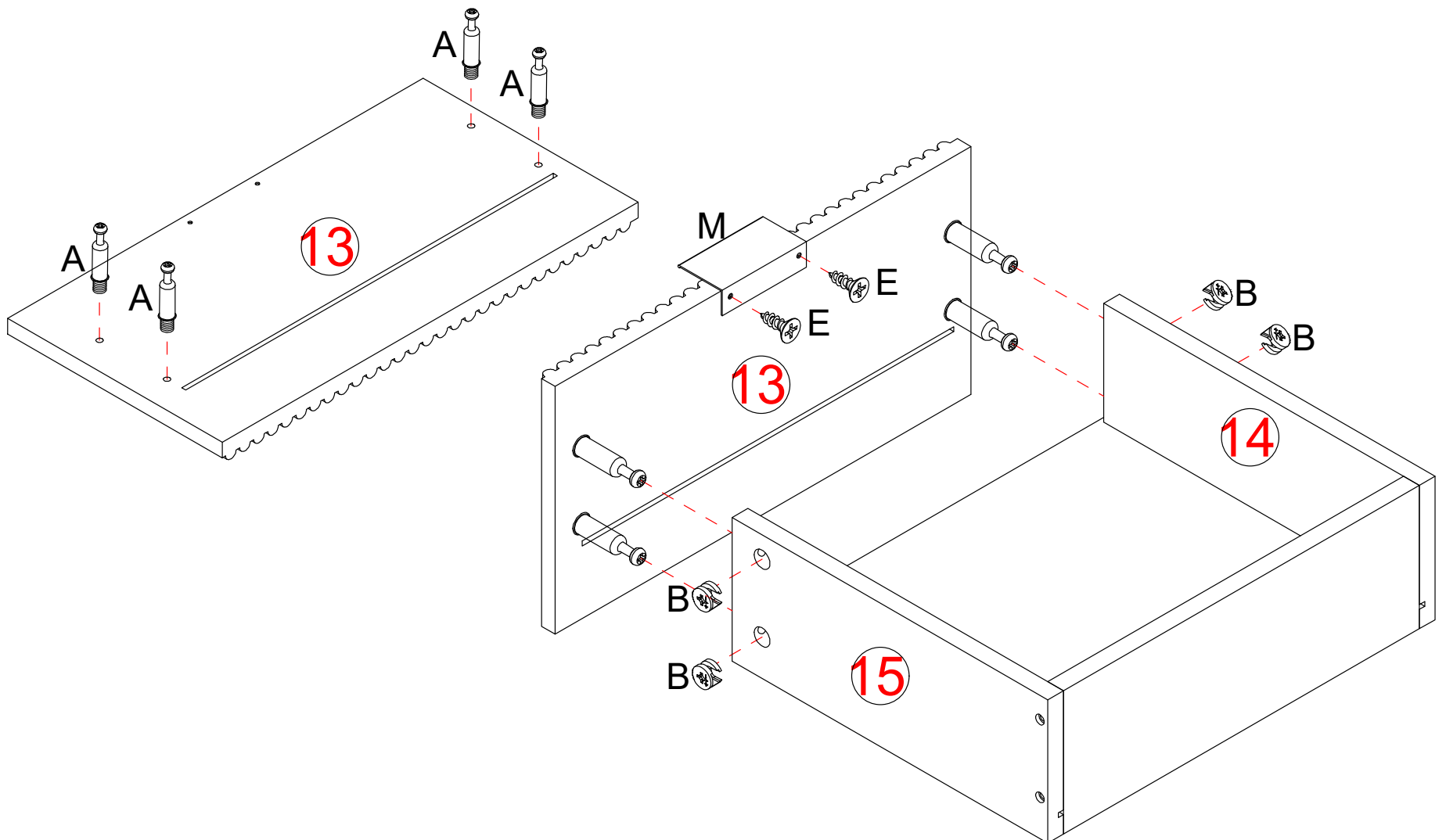
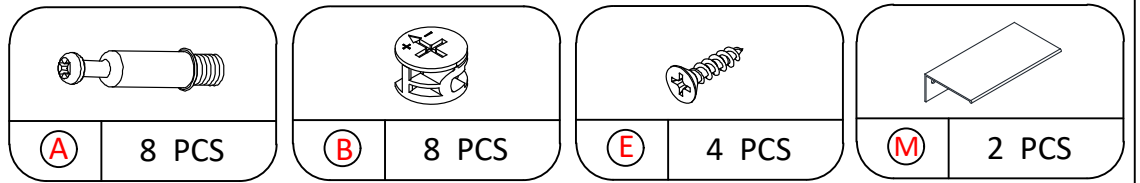

13

x2

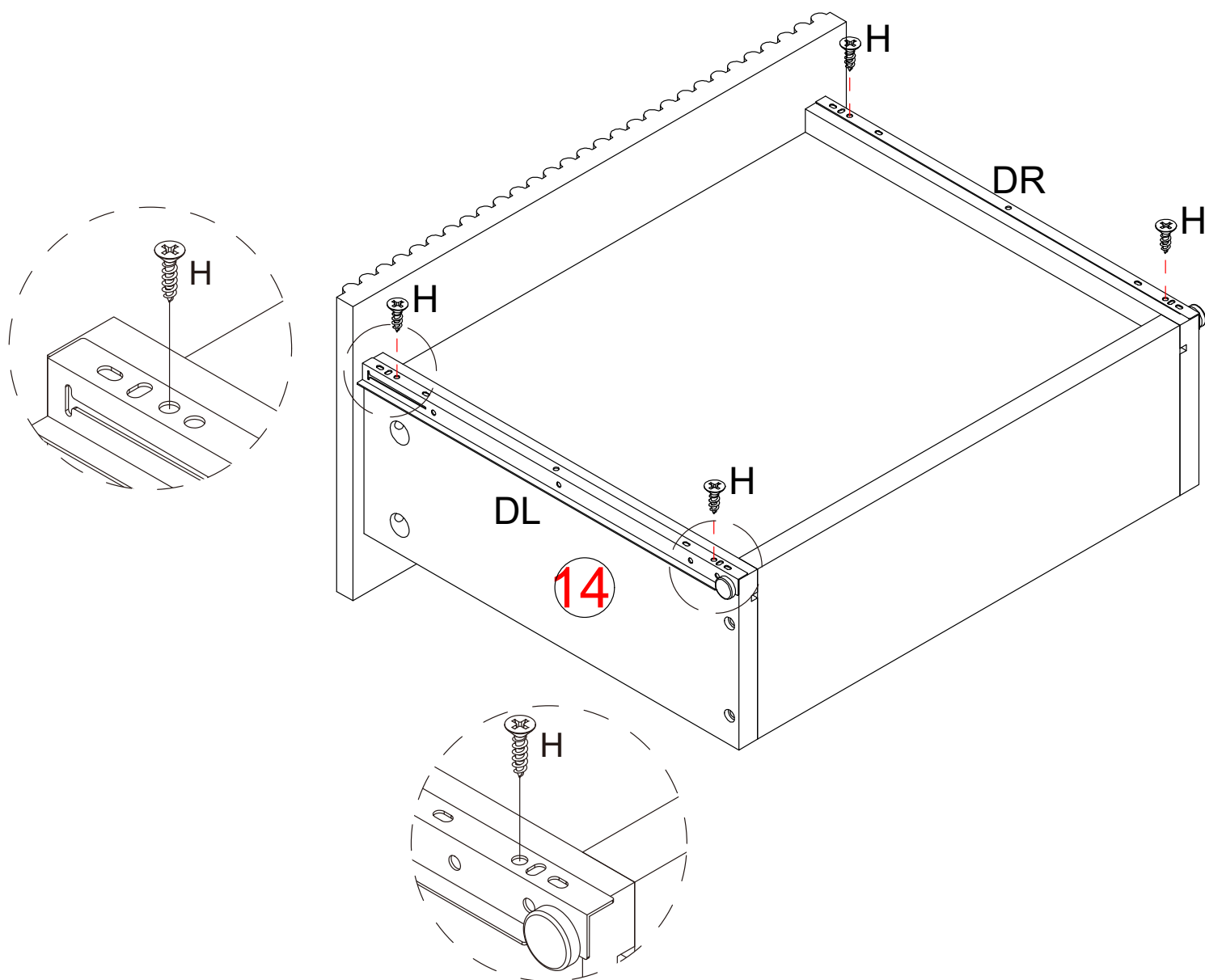
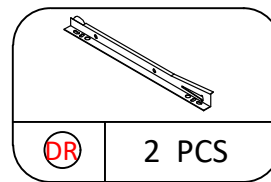
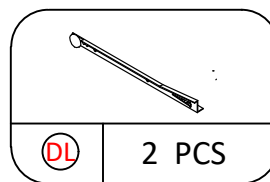
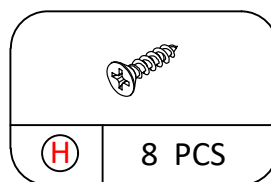

14

