

Installation sanleitung  
Installation Instruction  
Instruction d'installation

# Schlafsofa aus Holz

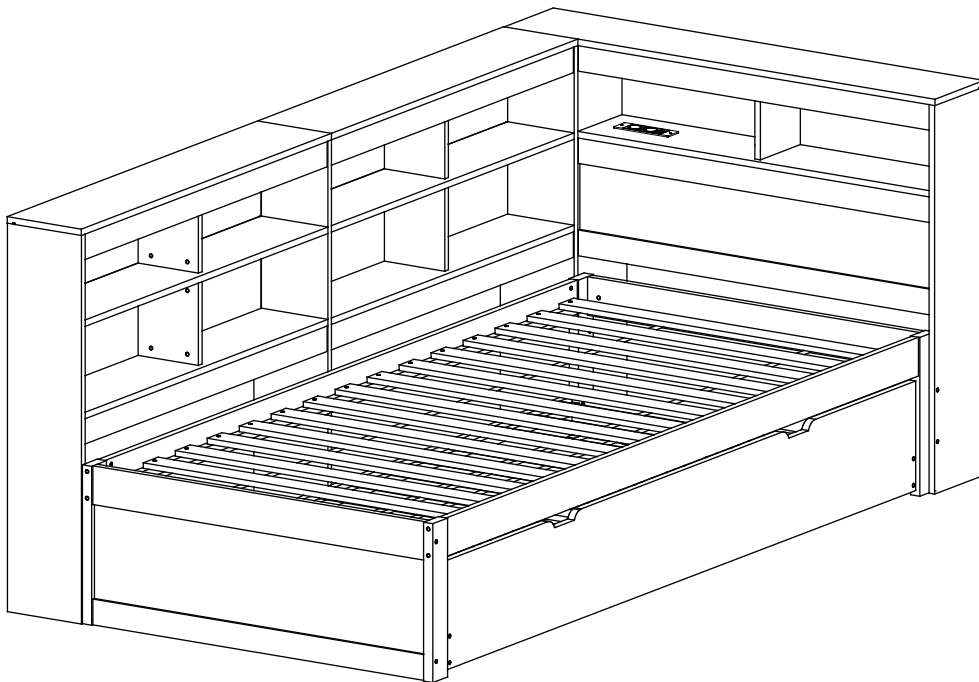

Unser Produkt wird Ihnen in 3 Paketen geliefert. Die Lieferzeiten dieser 3 Pakete können abweichen, bitte haben Sie etwas Geduld und vielen Dank für Ihr Verständnis.

Our product will be delivered to you in 3 packages. The delivery times of these 3 packages may differ, please be patient and thank you for your understanding.

Notre produit vous sera livré en 3 colis. Les délais de livraison de ces 3 colis peuvent différer, soyez patient et merci pour votre compréhension.



FR

Vous êtes responsable de remettre tous les appareils électriques et électroniques usagés à des points de collecte correspondants.

Pour en savoir plus:  
[www.quefairedelesdechets.fr](http://www.quefairedelesdechets.fr)

N623P241717/N623P241718/N623P241719

# INSTRUCTIONS

## IMPORTANT-READ CAREFULLY-RETAIN FOR FUTURE REFERENCE

- a) **WARNING** -Children can become trapped between the bed and the wall, the adjoining pieces of furniture (e.g. cupboards) and the like. To avoid risk of serious injury the distance between the safety barrier and the adjoining structure shall not exceed 90 mm or shall be more than 230 mm.
- b) **WARNING**-Do not use the bed if any structural part is broken or missing; Replacement parts are between requested from the manufacturer or the store.
- c) **WARNING**-Do not climb or wiggle on any non-designated structures.
- d) it is imperative to always follow the installation instructions and manufacturer's use.
- e) **The recommended size of the mattress to be used with the bed is 200cmx90cm, maximum thickness mattress:12cm.**
- f) It is necessary to ventilate the room in order to maintain a low level moisture and prevent mold growth in the bed and its periphery.
- g) Joining devices should always be tightened properly and regularly verified. Tighten if necessary.

# ANLEITUNGEN

## WICHTIG - SORGFÄLTIG LESEN - FÜR SPÄTERE VERWENDUNG

### AUFBEWAHREN

- a) **WARNUNG** - Kinder können zwischen dem Bett und der Wand, den angrenzenden Möbelstücken (z. B. Schränken) und der Lücke eingeklemmt werden. Um die Gefahr schwerer Verletzungen zu vermeiden, darf der Abstand zwischen der Sicherheitsbarriere und der angrenzenden Struktur nicht mehr als 90 mm oder mehr als 230 mm betragen.
- b) **WARNUNG**-Das Bett darf nicht benutzt werden, wenn ein Bauteil gebrochen ist oder fehlt; Ersatzteile sind beim Hersteller oder im Geschäft anzufordern.
- c) **WARNUNG** - Klettern oder wackeln Sie nicht auf nicht dafür vorgesehenen Strukturen.
- d) Befolgen Sie unbedingt die Installationsanweisungen und die Gebrauchsanweisungen des Herstellers.
- e) **Die empfohlene Größe der Matratze für das Bett beträgt 200x90cm, maximale Dicke der Matratze: 12cm.**
- f) Es ist notwendig, den Raum zu lüften, um die Feuchtigkeit niedrig zu halten und Schimmelbildung im Bett und seiner Umgebung zu verhindern.
- g) Die Verbindungselemente sollten immer richtig angezogen sein und regelmäßig überprüft werden. Ziehen Sie sie gegebenenfalls nach.

## English

### IMPORTANT ! KEEP FOR FUTURE REFERENCE : READ CAREFULLY

- To be assembled by an adult. Assembly must be checked by an adult before use
- WARNING ! Keep all screws, small parts and plastic bags out of the reach of children
- Properly identify all parts before assembling
- Never use your item if any of its parts are broken or missing
- Should any problems arise, please contact our After Sales Service
- Manufacturer's instructions shall be followed at all times
- Care: Clean with a soft, dry cloth. In case of larger stains, carefully rub with a slightly damp, non-abrasive sponge
- Avoid the risk of fire by not placing furniture near sources of ignition or hot items
- Do not jump on the bed

## Deutsch

### WICHTIG ! ZUM SPÄTEREN NACHSCHLAGEN AUFBEWAHREN: SORGFÄLTIG LESEN

- Muss von einem Erwachsenen zusammengebaut werden. Der Zusammenbau muss vor dem Gebrauch von einem Erwachsenen überprüft werden
- WARNUNG! Bewahren Sie alle Schrauben, Kleinteile und Plastikbeutel außerhalb der Reichweite von Kindern auf
- Kennzeichnen Sie vor dem Zusammenbau alle Teile richtig
- Benutzen Sie Ihren Artikel niemals, wenn Teile gebrochen sind oder fehlen
- Sollten Probleme auftreten, wenden Sie sich bitte an unseren Kundendienst
- Die Anweisungen des Herstellers sind stets zu befolgen
- Pflege: Mit einem weichen, trockenen Tuch reinigen. Bei größeren Flecken vorsichtig mit einem leicht feuchten, nicht scheuernden Schwamm abreiben. nicht scheuernden Schwamm
- Vermeiden Sie die Gefahr eines Brandes, indem Sie die Möbel nicht in der Nähe von Zündquellen oder heißen Gegenständen aufstellen
- Nicht auf das Bett springen

## Français

### IMPORTANT ! CONSERVER POUR RÉFÉRENCE ULTÉRIEURE : LIRE ATTENTIVEMENT

- Le montage doit être effectué par un adulte. Le montage doit être vérifié par un adulte avant Utilisation
- ATTENTION ! Tenir les vis, les petites pièces et les sachets en plastique hors de portée des enfants
- Identifiez correctement toutes les pièces avant de les assembler
- N'utilisez jamais votre article si l'une de ses pièces est cassée ou manquante
- En cas de problème, veuillez contacter notre service après-vente
- Les instructions du fabricant doivent être respectées à tout moment
- Entretien : nettoyer avec un chiffon doux et sec. En cas de taches plus importantes, frotter soigneusement avec une éponge non abrasive légèrement humide. légèrement humide et non Abrasive
- Évitez les risques d'incendie en ne plaçant pas les meubles à proximité de sources d'inflammation ou d'objets chauds
- Ne pas sauter sur le lit

## Italiano

### IMPORTANTE! CONSERVARE PER RIFERIMENTO FUTURO: LEGGERE ATTENTAMENTE

- Deve essere assemblato da un adulto. L'assemblaggio deve essere controllato da un adulto prima dell'uso
- **ATTENZIONE!** Tenere tutte le viti, le piccole parti e i sacchetti di plastica fuori dalla portata dei bambini
- Identificare correttamente tutte le parti prima dell'assemblaggio
- Non utilizzare mai l'articolo se alcune parti sono rotte o mancanti
- In caso di problemi, si prega di contattare il nostro Servizio Post Vendita
- Le istruzioni del produttore devono essere sempre seguite
- Cura: Pulire con un panno morbido e asciutto. In caso di macchie più estese, strofinare accuratamente con una spugna leggermente umida e nonspugna leggermente umida e non abrasiva
- Evitare il rischio di incendio, non collocando i mobili vicino a fonti di accensione o a oggetti caldi
- Non saltare sul letto

## Español

### ¡ IMPORTANTE ! CONSERVELO PARA FUTURAS CONSULTAS: LEA ATENTAMENTE

- Debe ser montado por un adulto. El montaje debe ser comprobado por un adulto antes del uso
- ADVERTENCIA Mantenga todos los tornillos, piezas pequeñas y bolsas de plástico fuera del alcance de los niños.
- Identifique correctamente todas las piezas antes de montarlas
  - Nunca utilice su artículo si alguna de sus piezas está rota o falta
  - Si surge algún problema, póngase en contacto con nuestro Servicio Postventa
  - Las instrucciones del fabricante deben seguirse en todo momento
  - Cuidado: Limpiar con un paño suave y seco. En caso de manchas más grandes, frote cuidadosamente con una esponja no abrasiva ligeramente humedecida.
  - Evite el riesgo de incendio no colocando los muebles cerca de fuentes de ignición u objetos calientes.
  - No saltar sobre la cama.

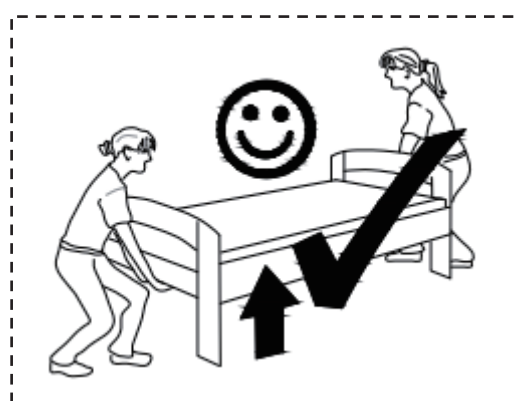
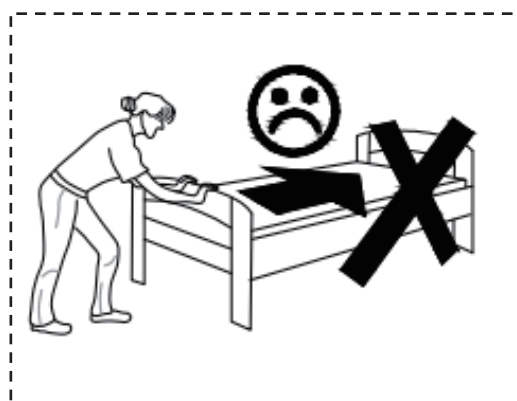

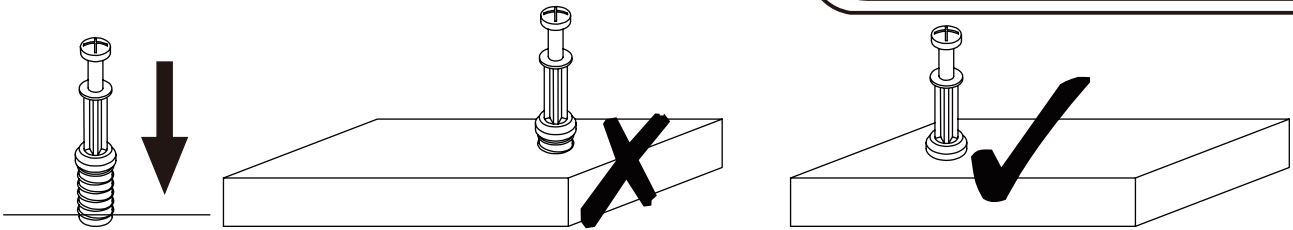

**EN\_QUICKFIT:** Tighten quickfit until shoulder is flush with panel. Do not overtighten or undertighten.

**FR\_RACCORD RAPIDE:** Faites serrer le raccord rapide jusqu'à ce que l'épaulement soit parfaitement encastré dans le panneau. Il ne faut ni trop serrer ni insuffisamment serrer.

**ES\_QUICKFIT:** Apriete quickfit hasta que el hombro se descargue con el panel. NO lo sobreapriete ni lo apriete poco.

**DE\_QUICKFIT:** Ziehen Sie den Quickfit fest, bis die Schulter mit der Platte bündig ist. Bitte nicht zu fest oder zu schwach anziehen.

**IT\_MONTAGGIO RAPIDO:** Stringere il montaggio rapido fino a quando la spalla è a filo con il pannello, non stringere troppo o troppo poco.

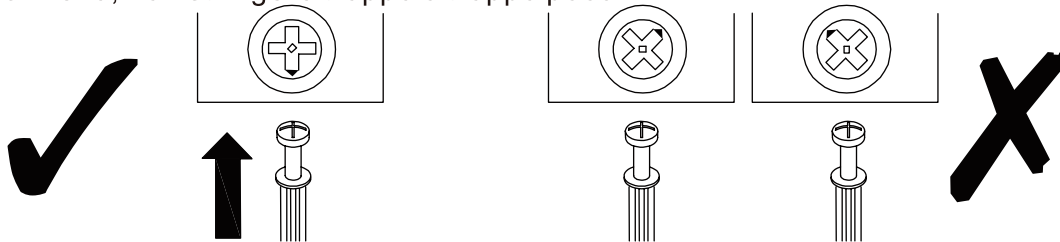

**EN\_CAM LOCK:** When fitting cam lock, ensure starting position is correct before you insert connecting quickfit.

**FR\_SERRURE BATTEUSE:** Avant d'insérer la serrure batteuse, veillez à la bonne orientation avant d'insérer le raccord rapide.

**ES\_CIERRE DE LA CÁMARA:** Cuando instale el cierre de la cámara, asegúrese de que la posición de inicio es correcta antes de que inserte el quickfit conector.

**DE\_CAM-LOCK:** Achten Sie bei der Montage des Cam-Locks auf die richtige Ausgangsposition, bevor Sie den Quickfit einsetzen.

**IT\_BLOCCAGGIO A CAMMA:** Quando si monta il bloccaggio a camma, assicurarsi che la posizione iniziale sia corretta prima di inserire il montaggio rapido di collegamento.

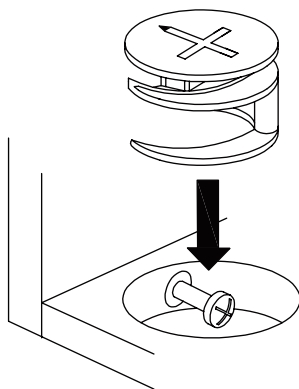

**EN\_Quickfit head** should be in the centre of the cam lock when the two panels are joined.

Cam lock should be inserted before quickfit.

**FR\_**Lorsque les deux panneaux sont assemblés, la tête du raccord rapide doit reposer au centre de la serrure batteuse.

Il faut insérer la serrure batteuse avant le raccord rapide.

**ES\_**El cabezal del quickfit debe estar en el centro del cierre de la cámara cuando se unan los dos paneles.

Se debe insertar el cierre de la cámara antes que el quickfit.

**DE\_**Der Quickfit-Kopf sollte sich in der Mitte des Cam-Locks befinden, wenn die beiden Platten zusammengefügt sind.

Der Cam-Lock sollte vor dem Quickfit eingesetzt werden.

**IT\_**La testa del montaggio rapido deve trovarsi al centro del bloccaggio a camma quando i due pannelli sono uniti.

Il Bloccaggio a Camma deve essere inserito prima del montaggio rapido.

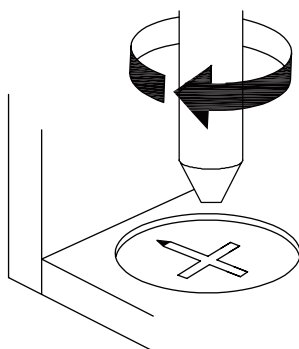

**EN\_**Turn cam lock clockwise to tighten.

**FR\_**Faites tourner la serrure batteuse dans le sens des aiguilles d'une montre pour la resserrer.

**ES\_**Gire el cierre de la cámara en sentido horario para apretarlo.

**DE\_**Drehen Sie den Cam-Lock im Uhrzeigersinn, um ihn festzuziehen.

**IT\_**Ruotare il bloccaggio a camma in senso orario per stringere.

**DE:** Vor dem Einbau die Schrauben in die Löcher stecken und festziehen, aber nicht bis 100%, 70% bis 80% anziehen reicht aus. Schließlich, nachdem alle Schrauben installiert sind, ziehen Sie alle Schrauben auf 100%. Wenn Sie auf diese Probleme stoßen, wie z. B. Fehlausrichtung der Löcher oder Unfähigkeit, bestimmte Teile zu installieren, überprüfen Sie bitte, ob die Schrauben korrekt verwendet werden und passen Sie die Dichtigkeit der Schrauben an.

**UK:** Before installation, insert the screws into the holes and tighten them, but do not tighten them to 100%, 70% to 80% is sufficient. Finally, after all screws are installed, tighten all screws to 100%. If you encounter these issues, such as if the holes cannot be aligned or some parts cannot be installed, please check if the screws are used correctly and adjust the tightness of the screws.

**FR:** Insérer la vis dans le trou avant la fin de l'assemblage, serrer la vis, mais ne pas serrer à 100%, 70% ~ 80% est correct. Enfin, une fois que toutes les vis sont bien serrées, toutes les vis sont serrées à 100%. Si vous rencontrez ces problèmes, par exemple si les trous ne sont pas alignés ou si certaines pièces ne peuvent pas être montées, vérifiez que les vis sont utilisées correctement et Ajustez leur serrage.

# Detailansicht

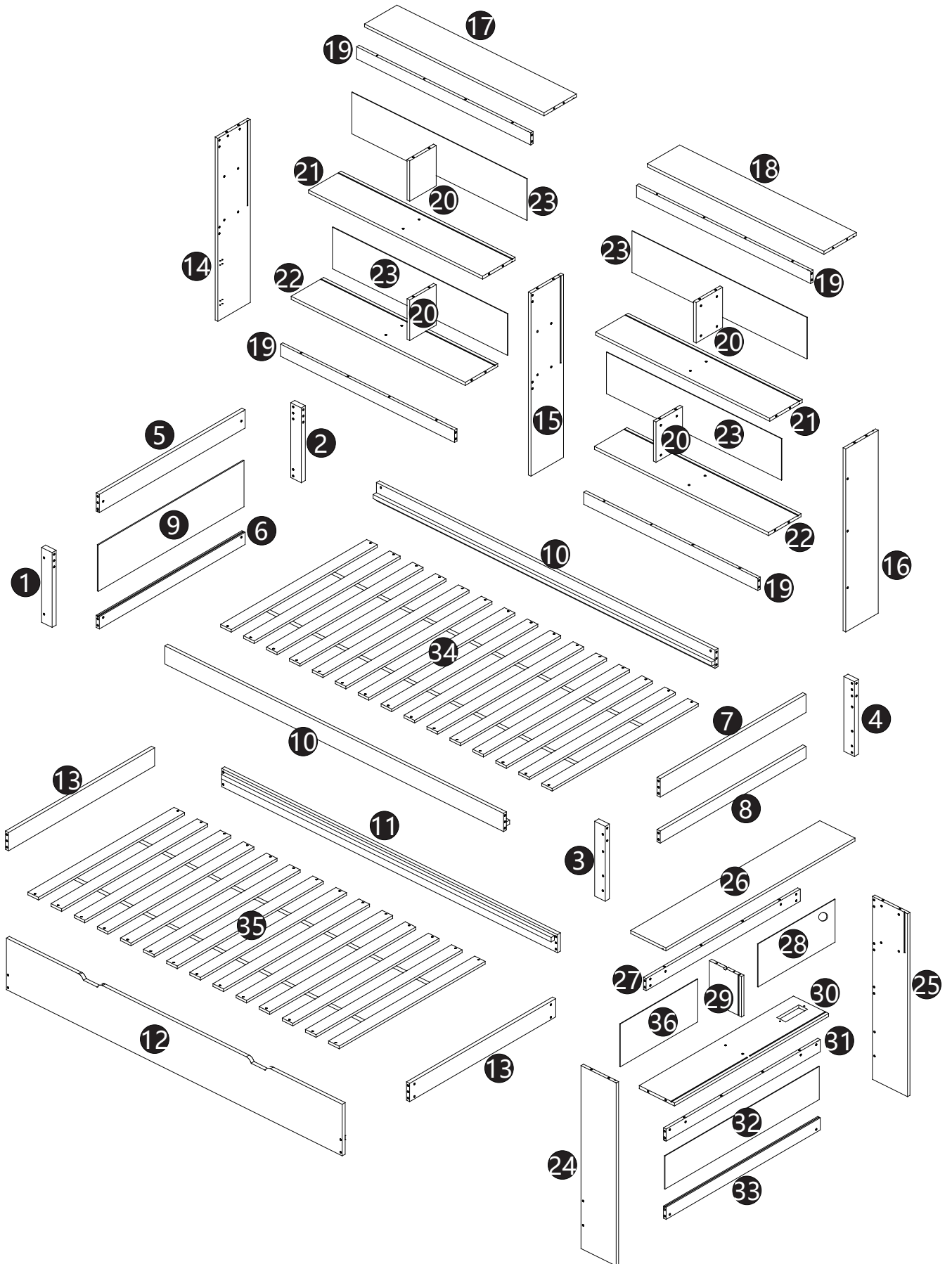

# N623P241717

14 x 1



15 x 1



16 x 1



24 x 1



25 x 1



27 x 1

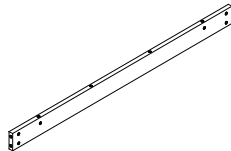

30 x 1

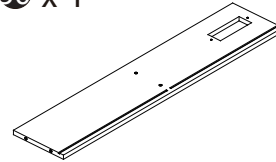

31 x 1

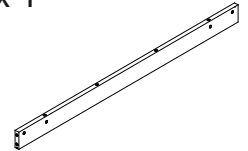

33 x 1

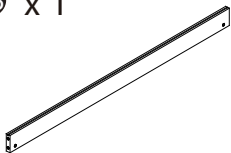

34 x 1

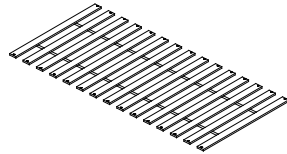

35 x 1

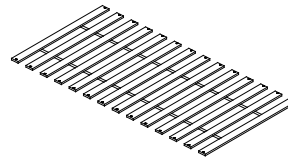

# N623P241718

5 x 1

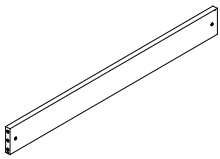

6 x 1

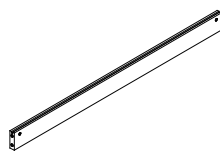

7 x 1

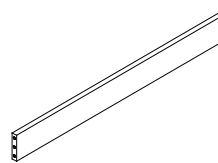

8 x 1

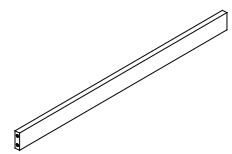

13 x 2

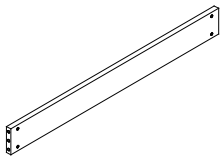

17 x 1

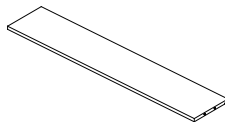

18 x 1

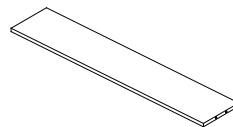

20 x 4

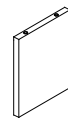

21 x 2

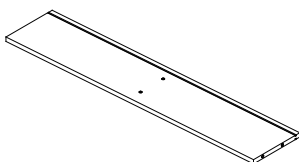

22 x 2

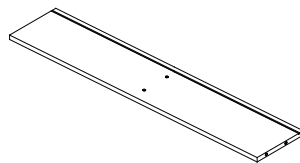

26 x 1

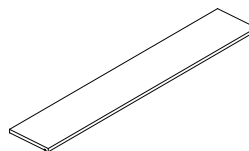

29 x 1

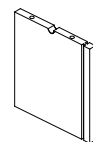

# N623P241719

1 x 1

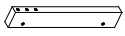

2 x 1



3 x 1

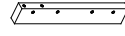

4 x 1

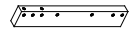

9 x 1

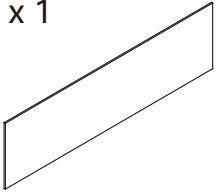

10 x 2

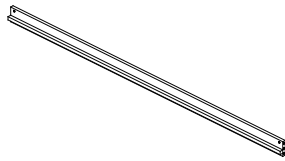

11 x 1

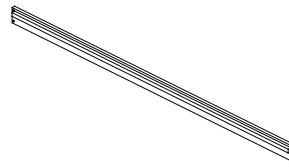

12 x 1

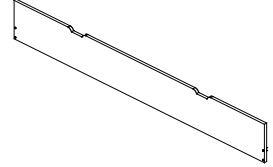

19 x 4

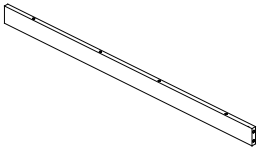

23 x 4

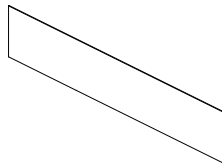

28 x 1

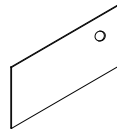



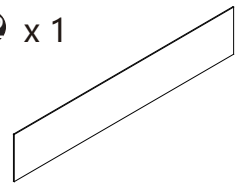



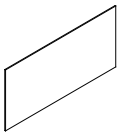







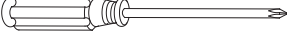

32 x 1





36 x 1

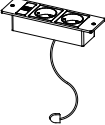

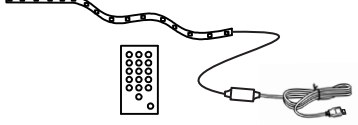
# N623P241718



<b>A</b> 	<b>B</b> 	<b>C</b> 
M6*60mm (16pcs)	M6*100mm(8pcs)	$\Phi$ 10*10.5mm(24pcs)
<b>D</b> 	<b>E</b> 	<b>F</b> 
$\Phi$ 8*40mm (36pcs)	$\Phi$ 3.5*30mm(58pcs)	M4 (2pcs)
<b>G</b> 	<b>H</b> 	<b>J</b> 
(1pc)	(93pcs)	(93pcs)
<b>K</b> 	<b>L</b> 	<b>M</b> 
M6*12mm(4pcs)	M6*35mm (4pcs)	(4pcs)
<b>N</b> 	<b>P</b> 	<b>Q</b> 
$\Phi$ 3.5*14mm(62pcs)	(32pcs)	(1pc)
<b>R</b> 	<b>S</b> 	<b>T</b> 
(2pcs)	(2pcs)	(1pc)

<b>A</b> 	<b>B</b> 	<b>L</b> 
M6*60mm	M6*100mm	M6*35mm

**DE:**Bitte beachten Sie, dass die Formen der Schrauben A und B und L ähnlich sind. Bitte installieren Sie entsprechend der Anleitung und unterscheiden Sie sie!

**UK:**Please note that the shapes of screws A and B and L are similar. Please install according to the instructions and distinguish them!

**FR:**Notez que les vis A et B et L ont des formes similaires. Veuillez les installer en suivant les instructions pour les séparer!





<b>E</b> 	<b>N</b> 
Φ3.5*30mm	Φ3.5*14mm

**DE:**Bitte beachten Sie, dass die Formen der Schrauben E und N ähnlich sind. Bitte installieren Sie entsprechend der Anleitung und unterscheiden Sie sie!



**UK:**Please note that the shapes of screws E and N are similar. Please install according to the instructions and distinguish them!

**FR:**Notez que les vis E et N ont des formes similaires. Veuillez les installer en suivant les instructions pour les séparer!



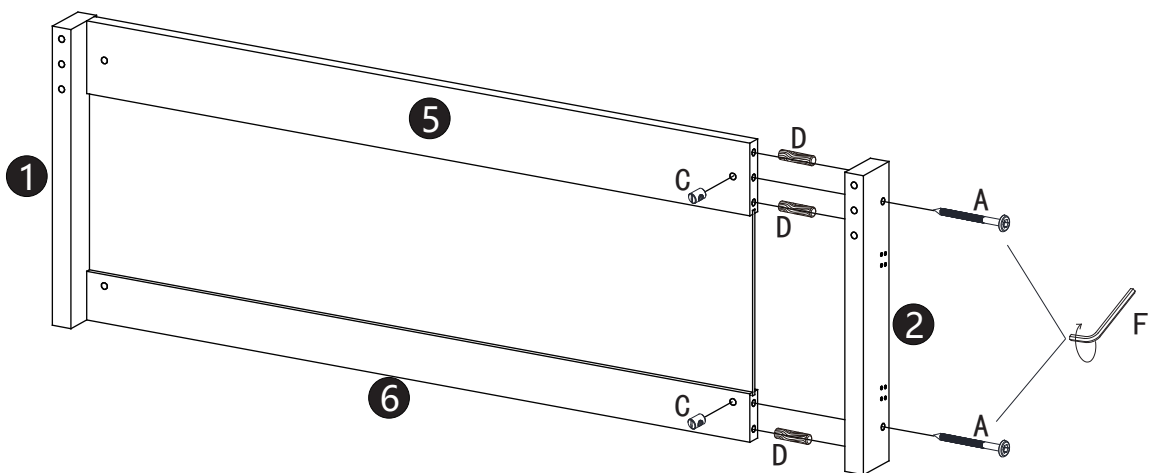
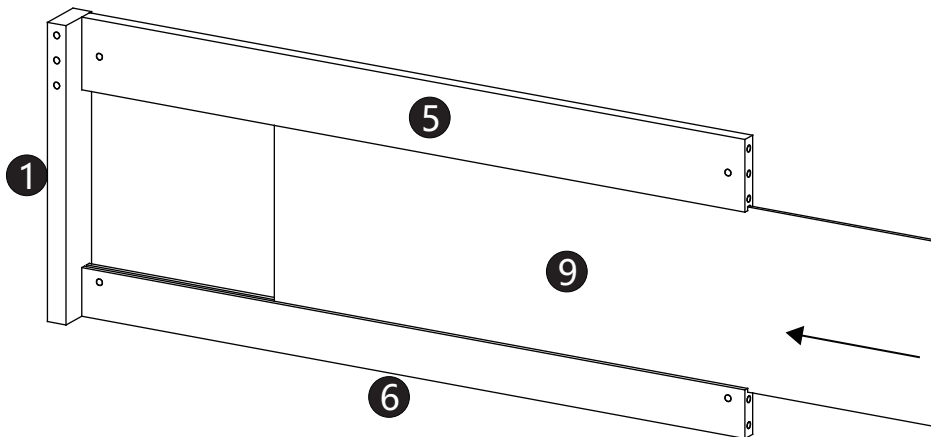
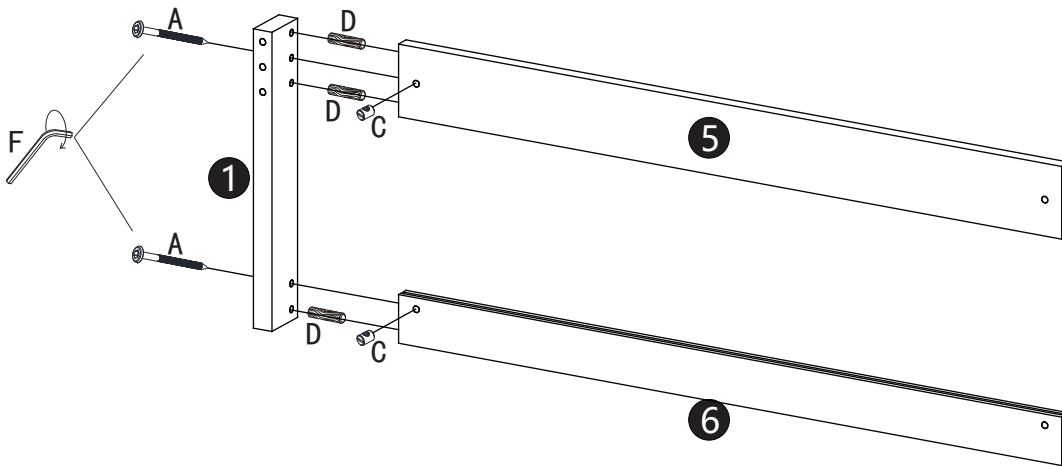

# SCHRITT 1:

<b>A</b>		<b>C</b>		<b>D</b>		<b>F</b>	
4PCS		4PCS		6PCS		1PC	





<b>A</b>		<b>B</b>		<b>L</b>	
M6*60mm (4pcs)		<del>M6*100mm</del>		<del>M6*35mm</del>	



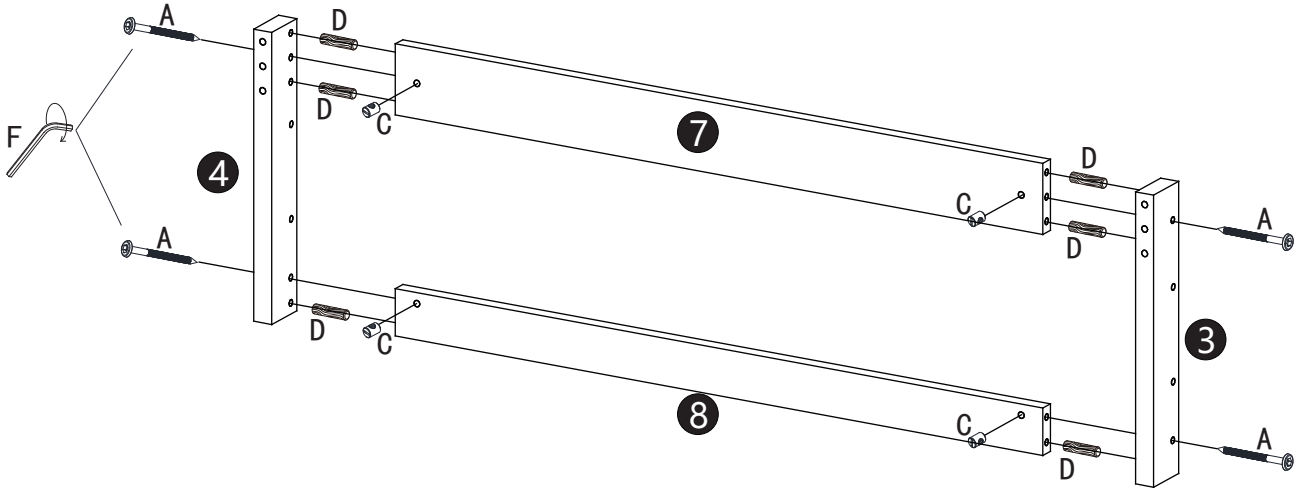

## SCHRITT 2:

<b>A</b>		<b>C</b>		<b>D</b>		<b>F</b>	
4PCS		4PCS		6PCS		1PC	





<b>A</b>		<b>B</b>		<b>L</b>	
M6*60mm (4pcs)		M6*100mm		M6*35mm	



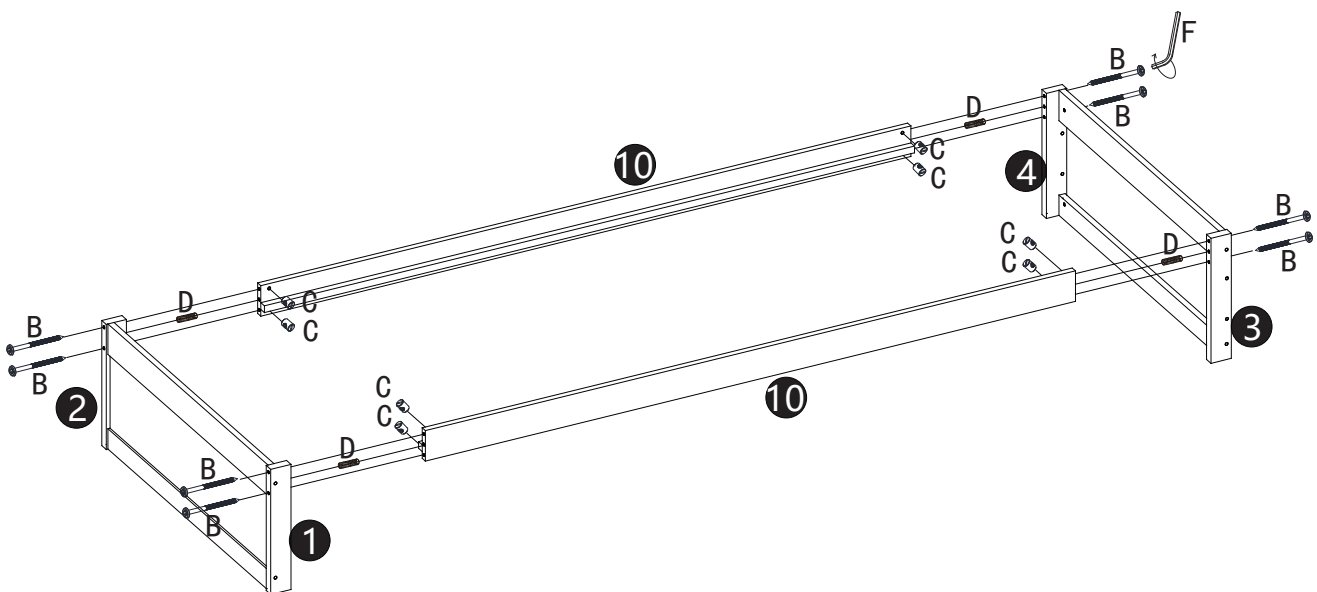

## SCHRITT 3:

<b>B</b>		<b>C</b>		<b>D</b>		<b>F</b>	
8PCS		8PCS		4PCS		1PC	



<b>B</b>		<b>A</b>		<b>L</b>	
M6*100mm(8pcs)		M6*60mm		M6*35mm	

# SCHRITT 4:

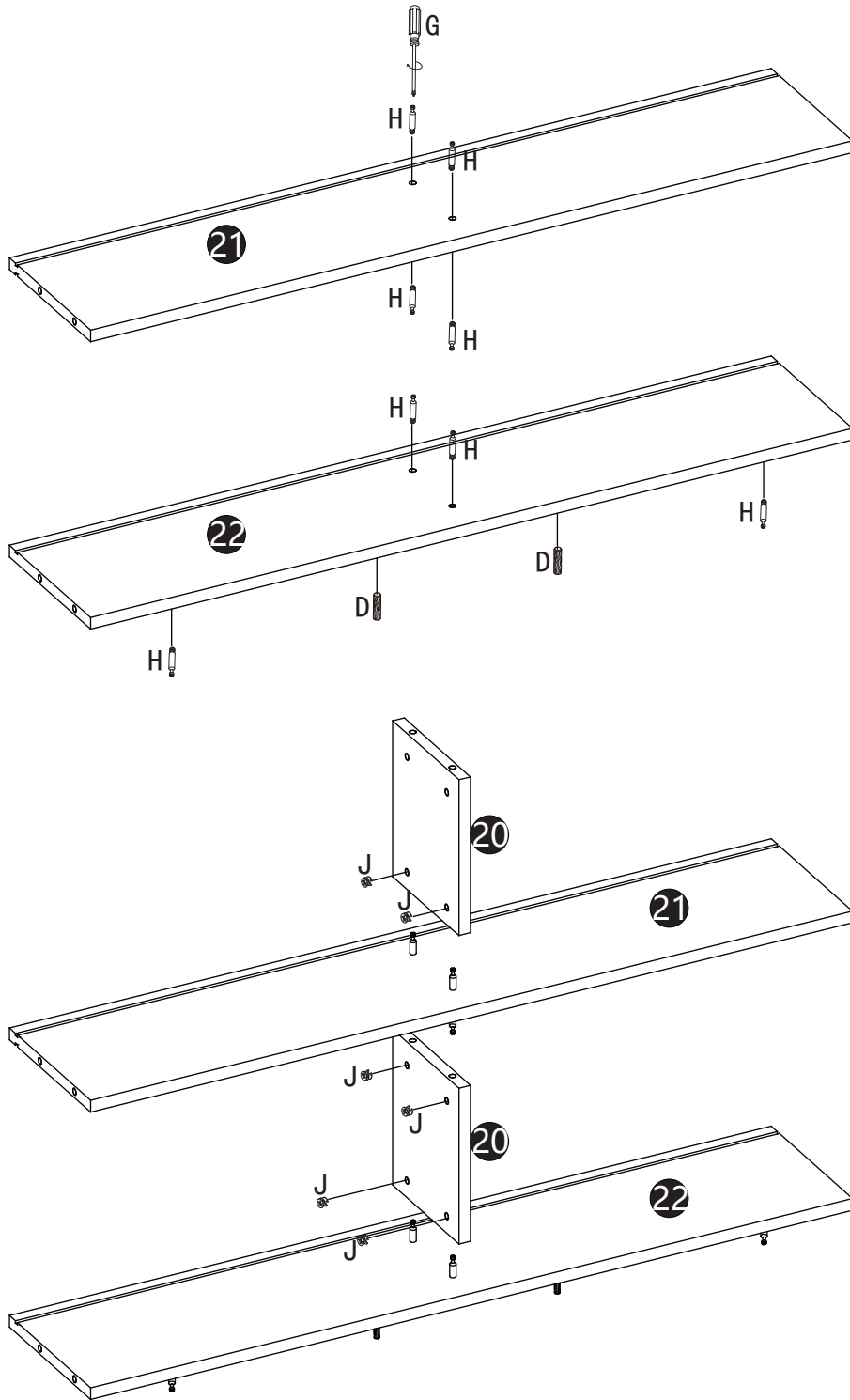

D		G		H		J	
4PCS		1PC		16PCS		12PCS	

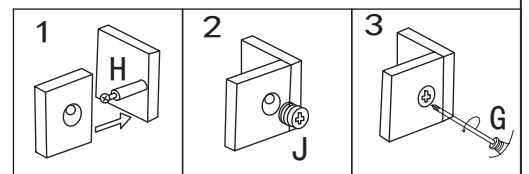

x2



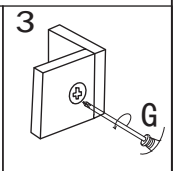
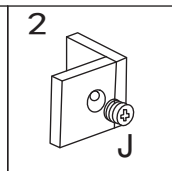
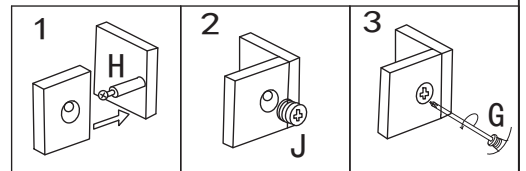
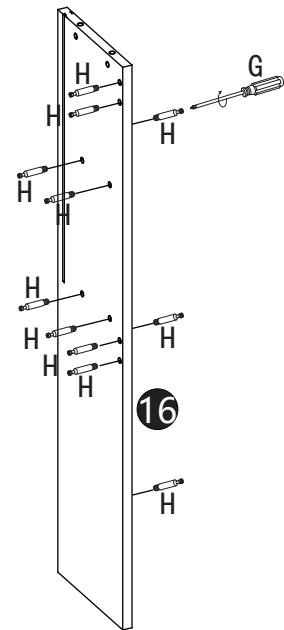
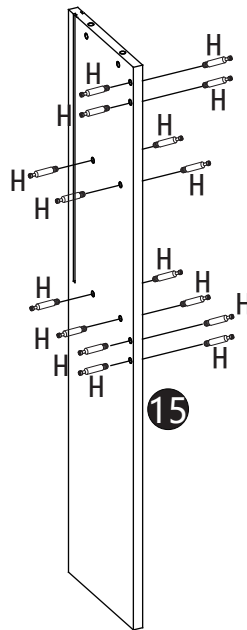
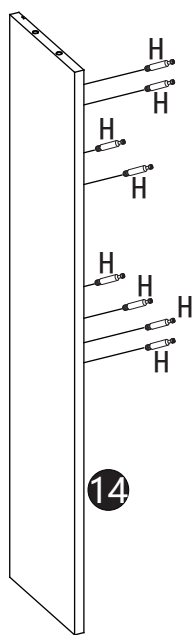
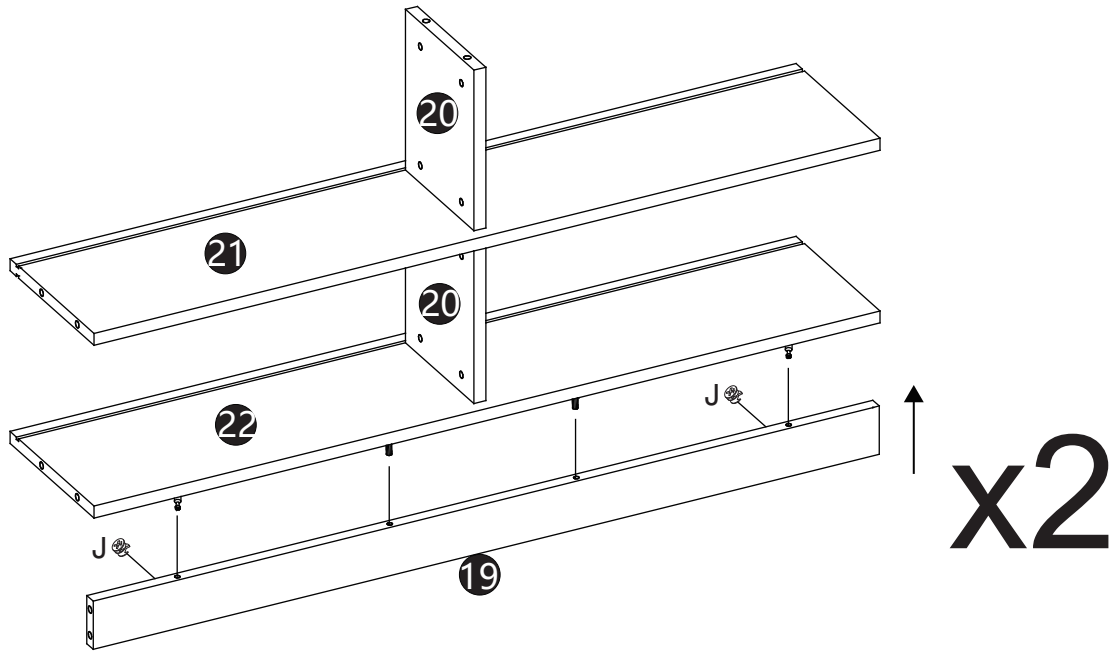

# SCHRITT 5:

<b>G</b>		<b>H</b>		<b>J</b>	
	<b>1 PC</b>		<b>35 PCS</b>		<b>4 PCS</b>



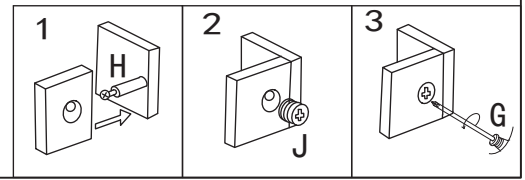
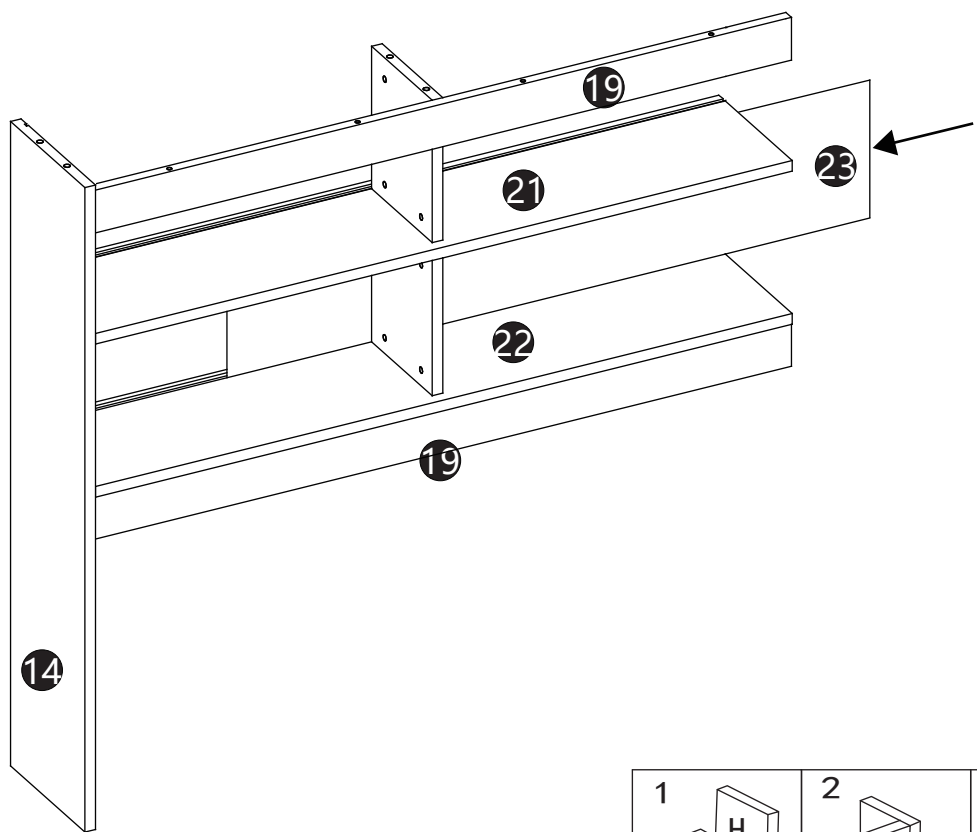
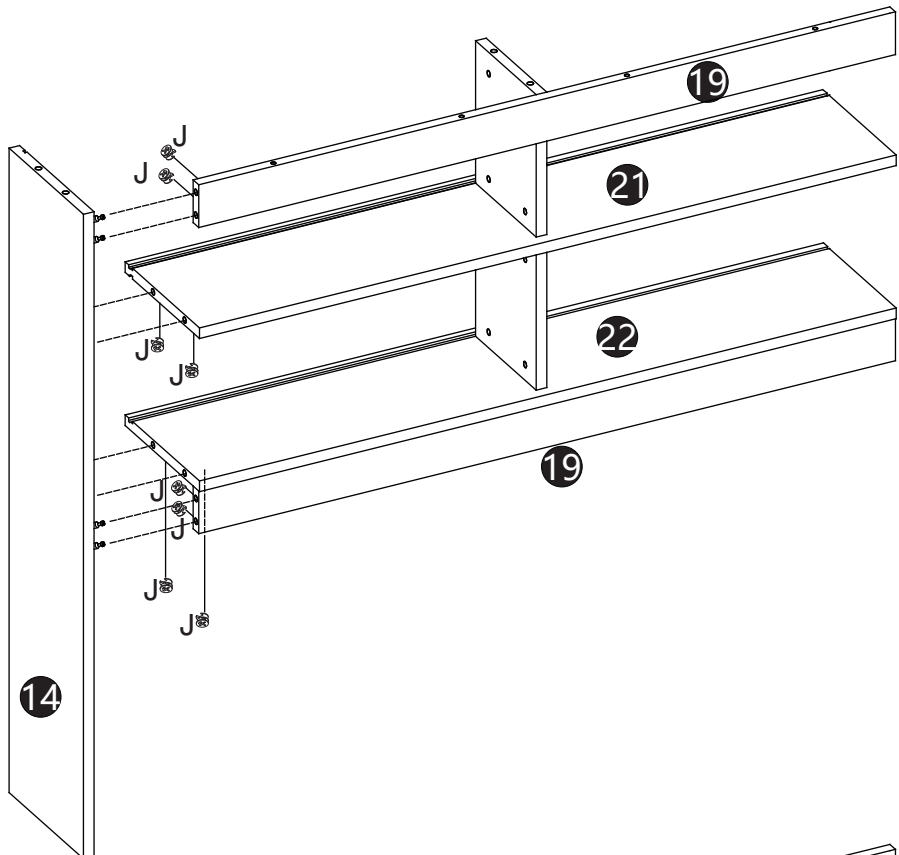

# SCHRITT 6:

G		J	
1PC		8PCS	



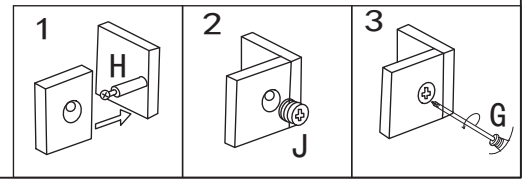
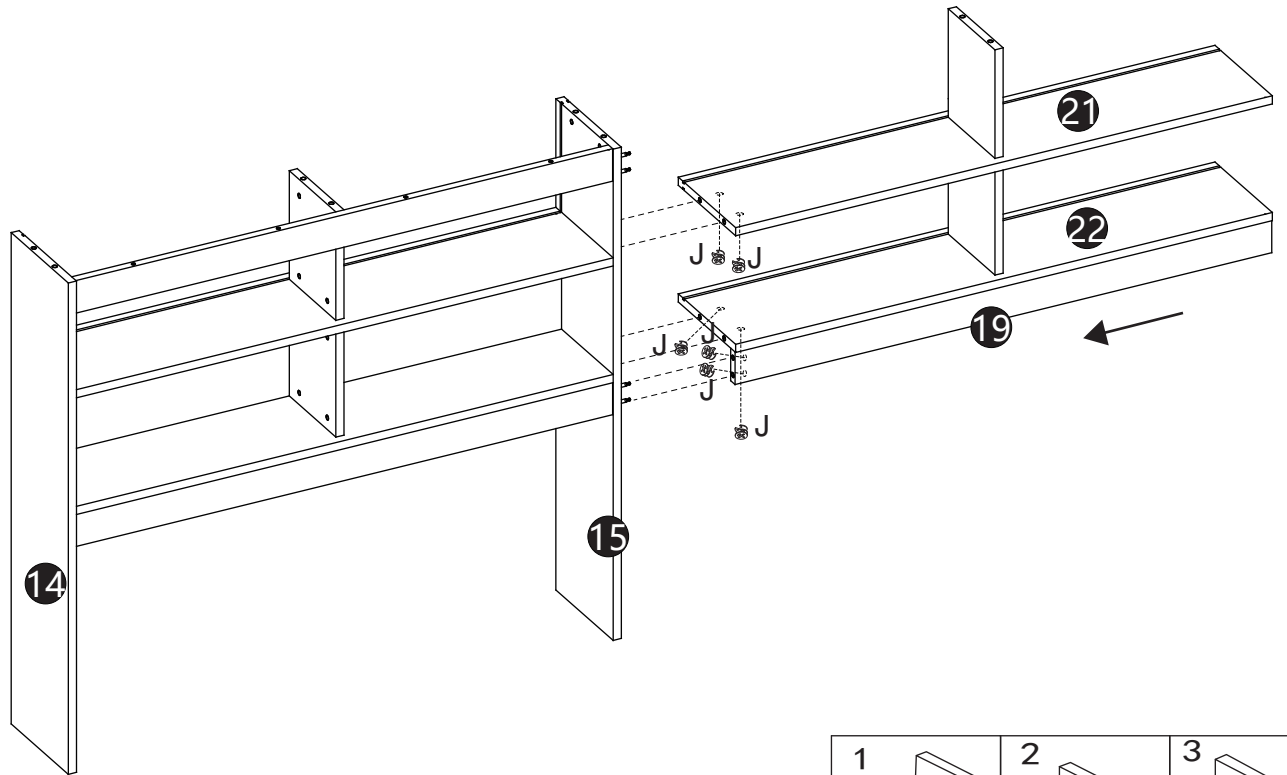
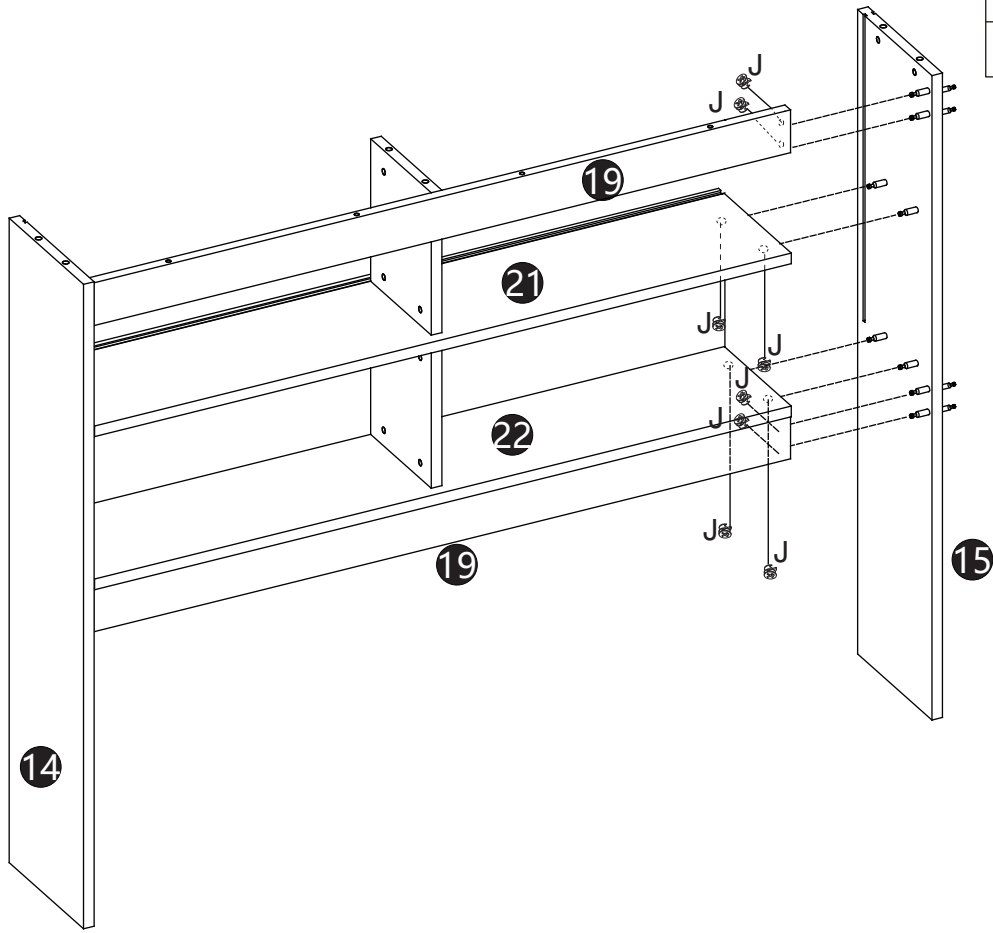

# SCHRITT 7:

G		J	
1PC		14PCS	



# SCHRITT 8:



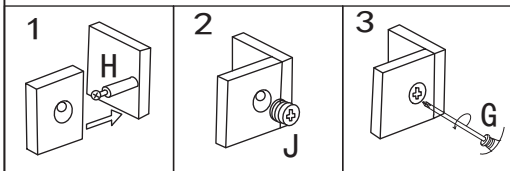
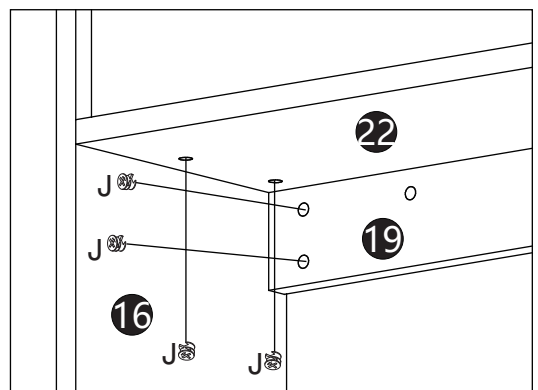
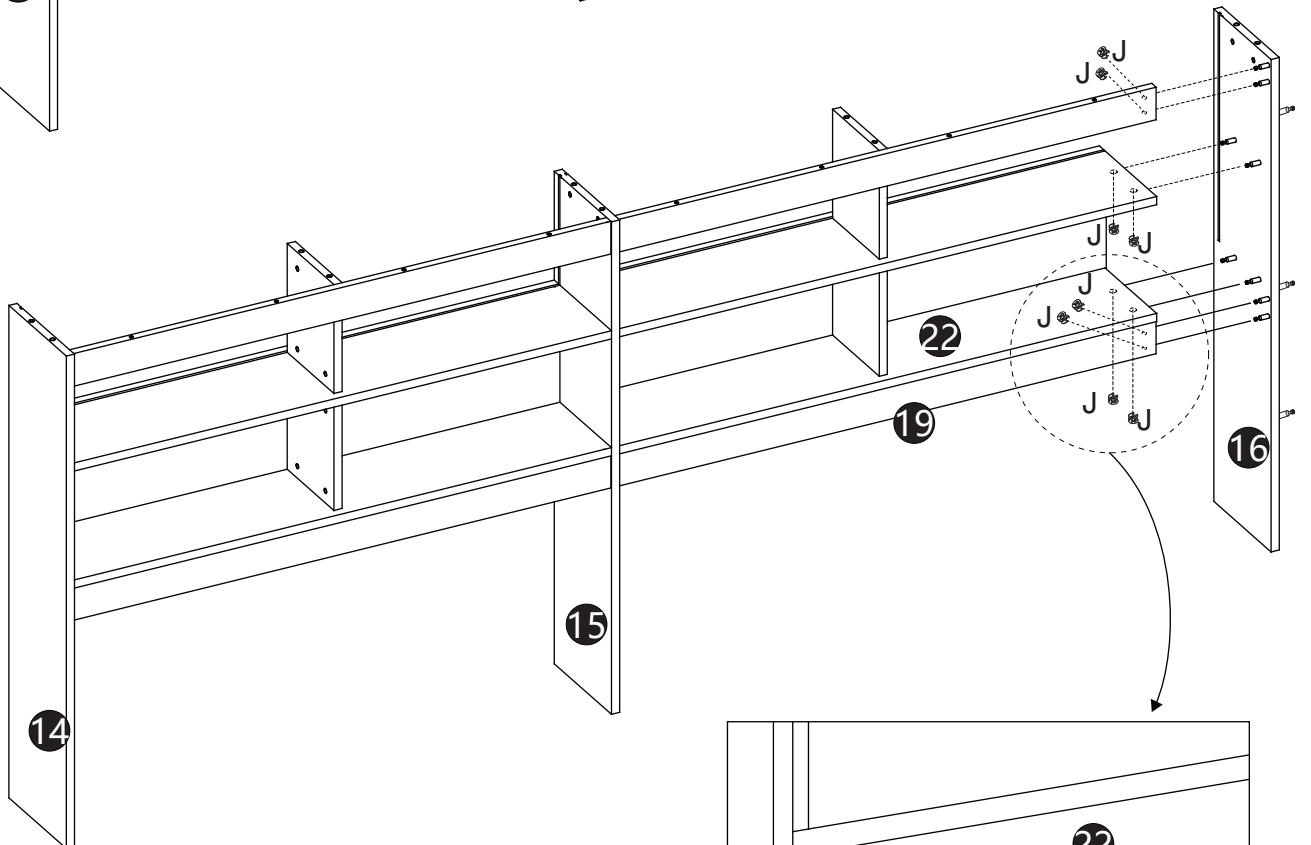
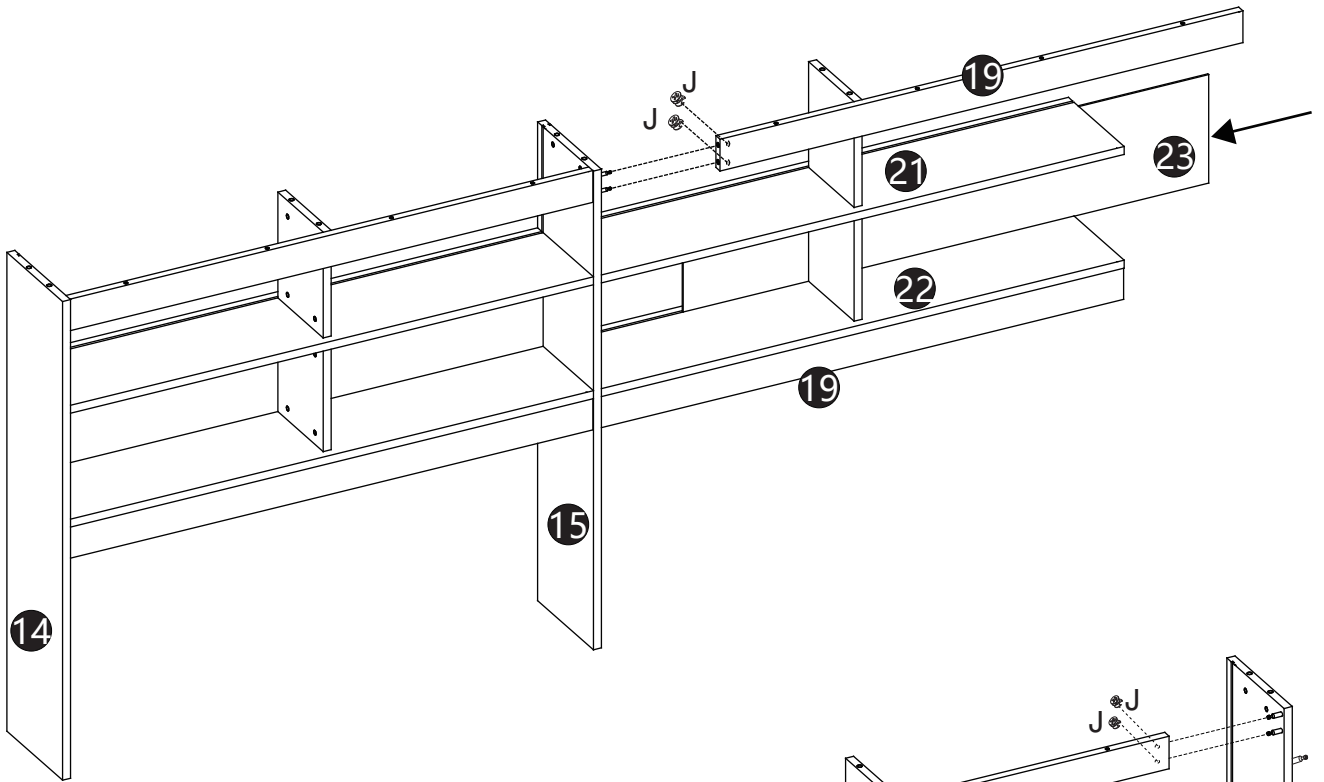

G		J	
1PC		10PCS	

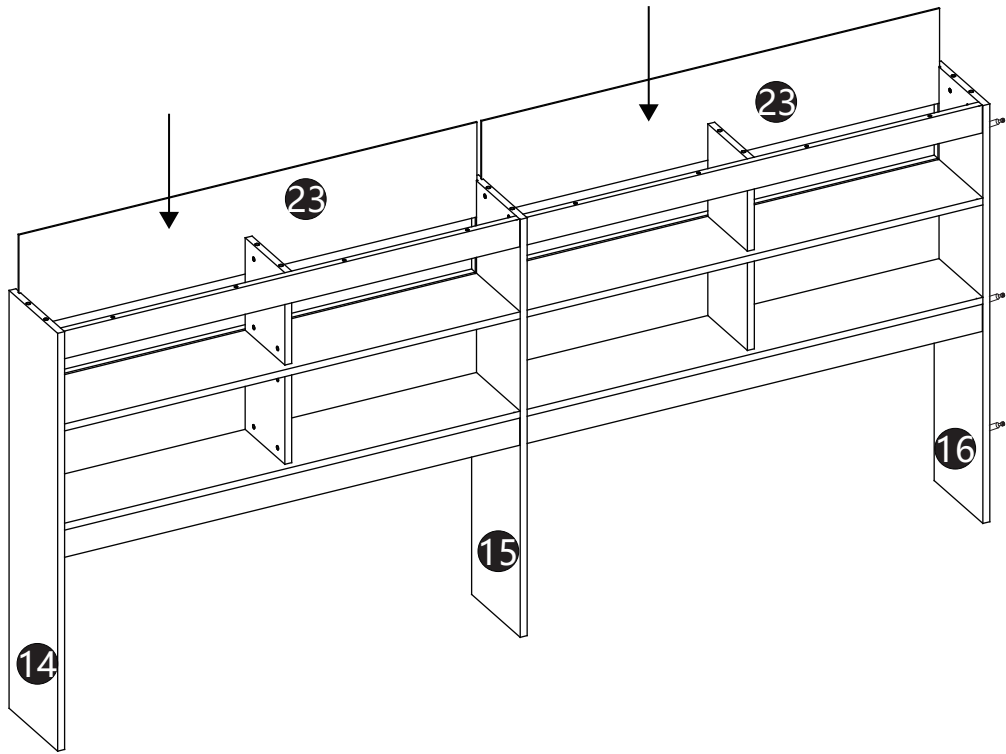

# SCHRITT 9:



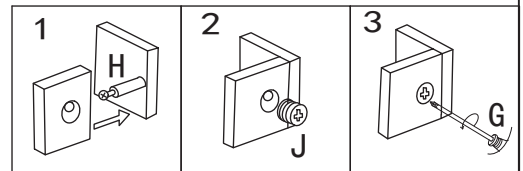
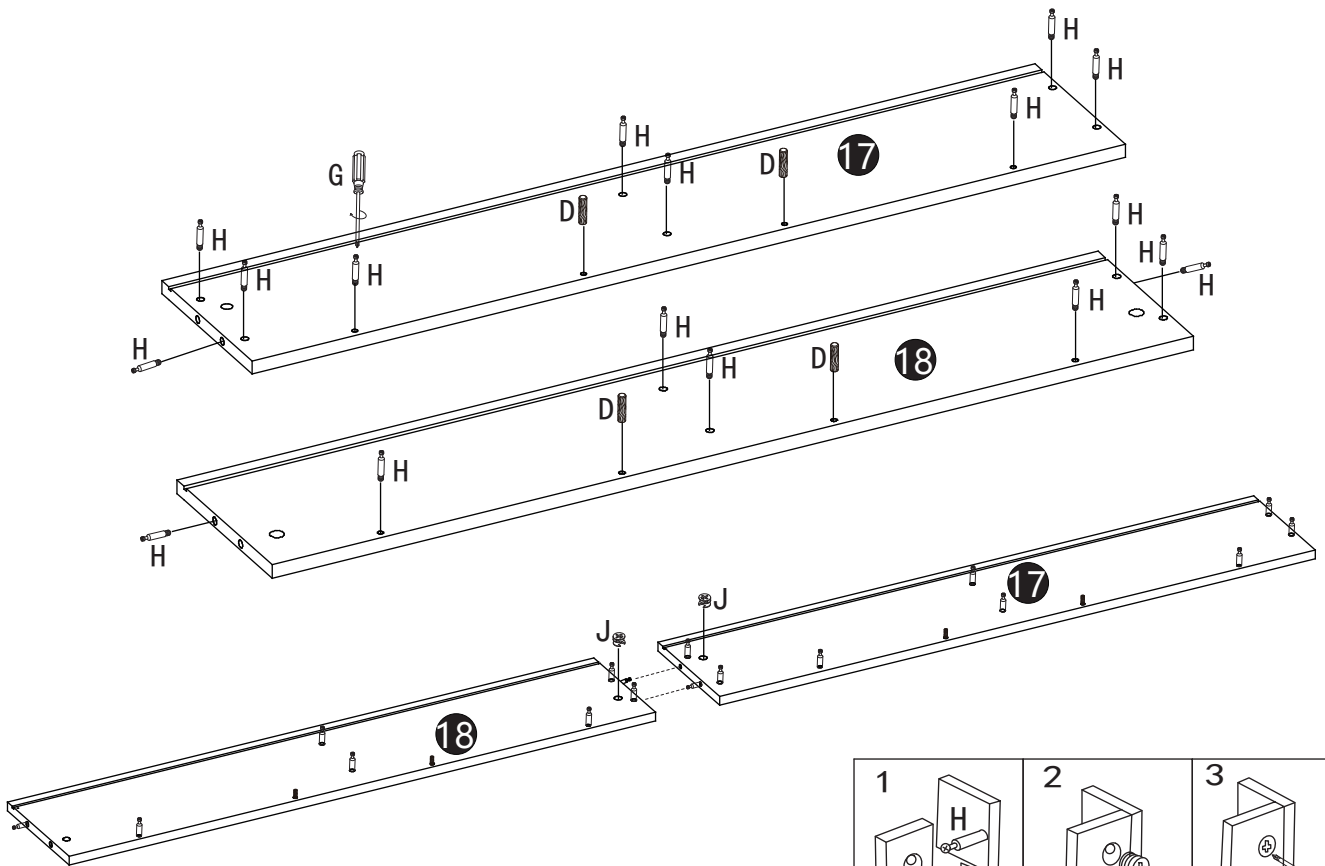

# SCHRITT 10:

<b>D</b>		<b>G</b>		<b>H</b>		<b>J</b>	
<b>4PCS</b>		<b>1PC</b>		<b>17PCS</b>		<b>2PCS</b>	





# SCHRITT 11:

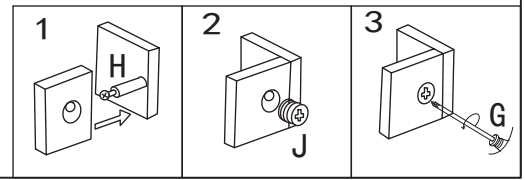
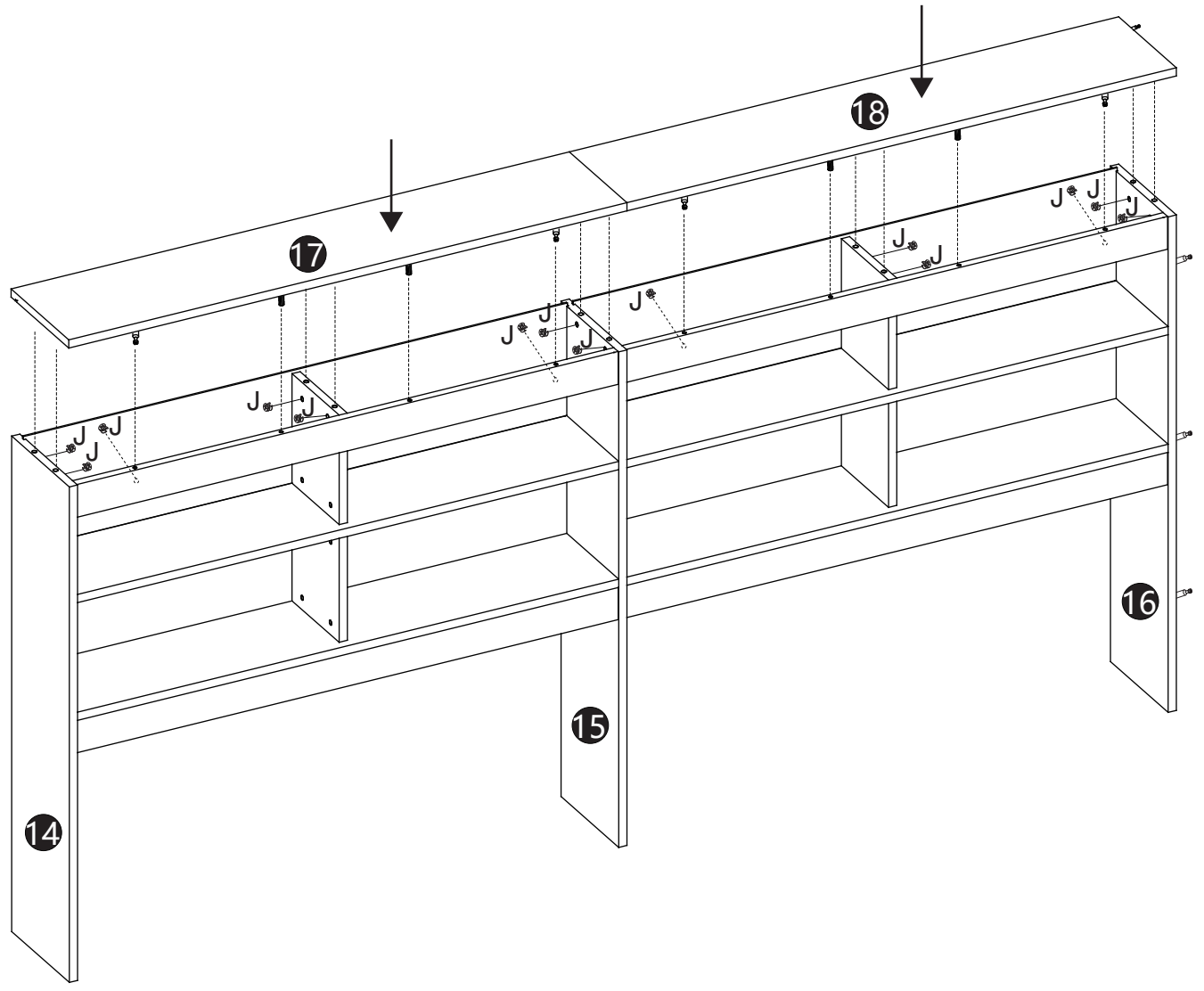

G		J	
1PC		14PCS	





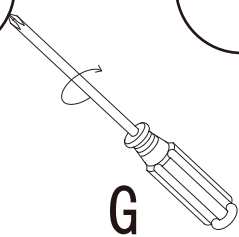
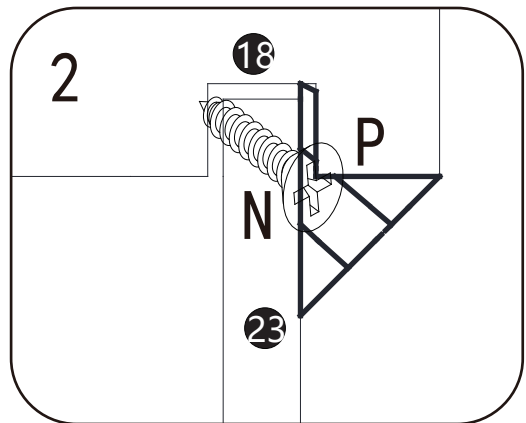
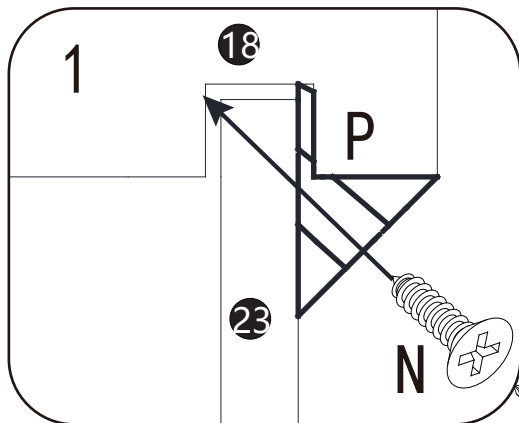
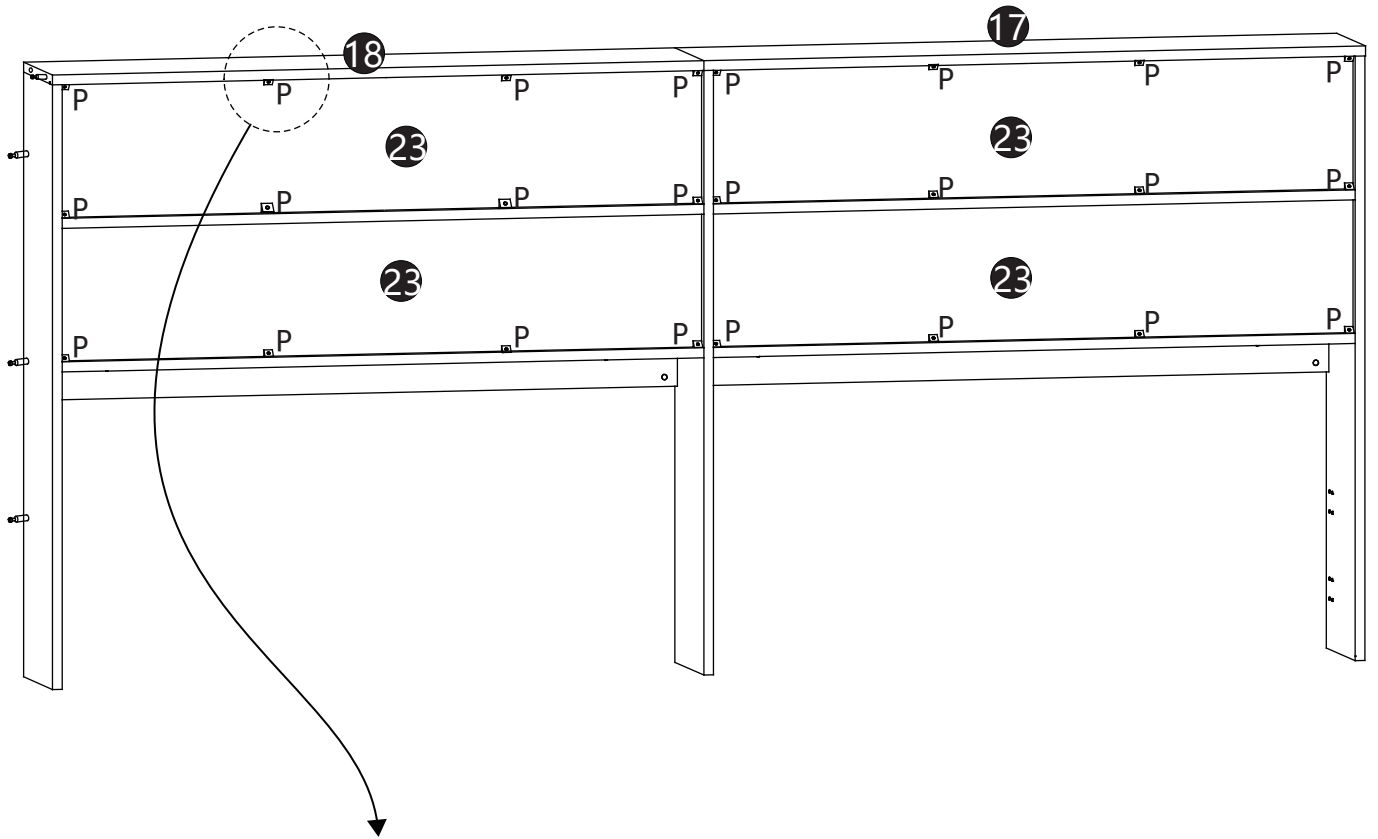

# SCHRITT 12:

<b>G</b>		<b>P</b>		<b>N</b>	
	<b>1 PC</b>	<b>24 PCS</b>	<b>24 PCS</b>		





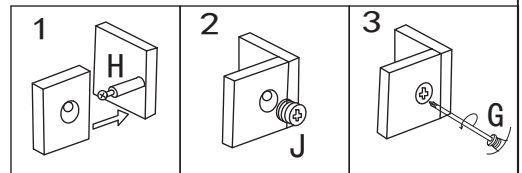
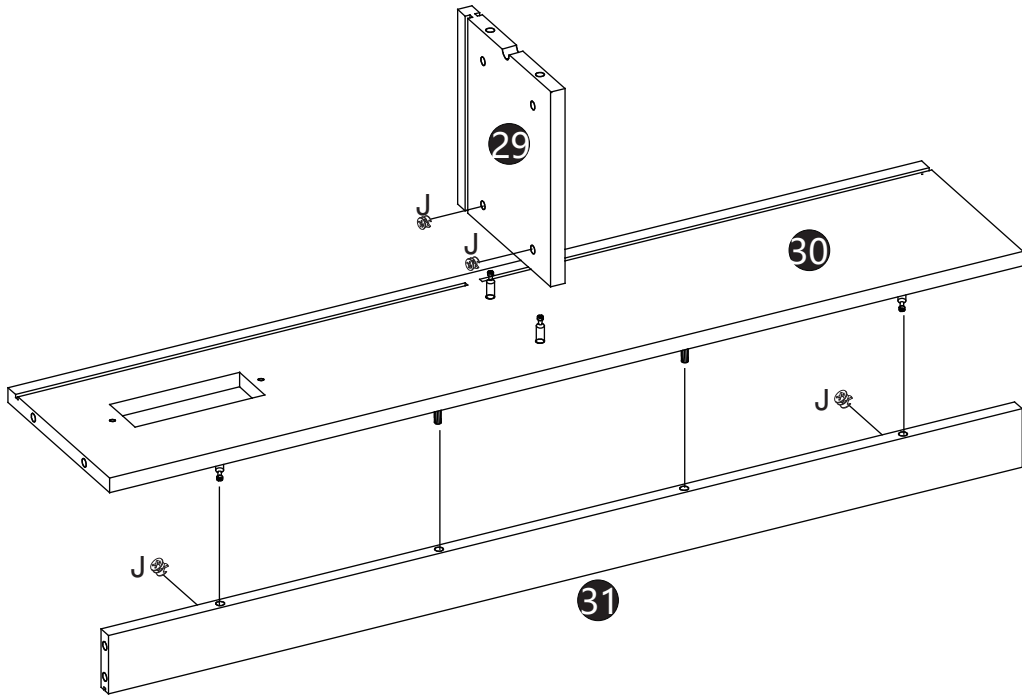
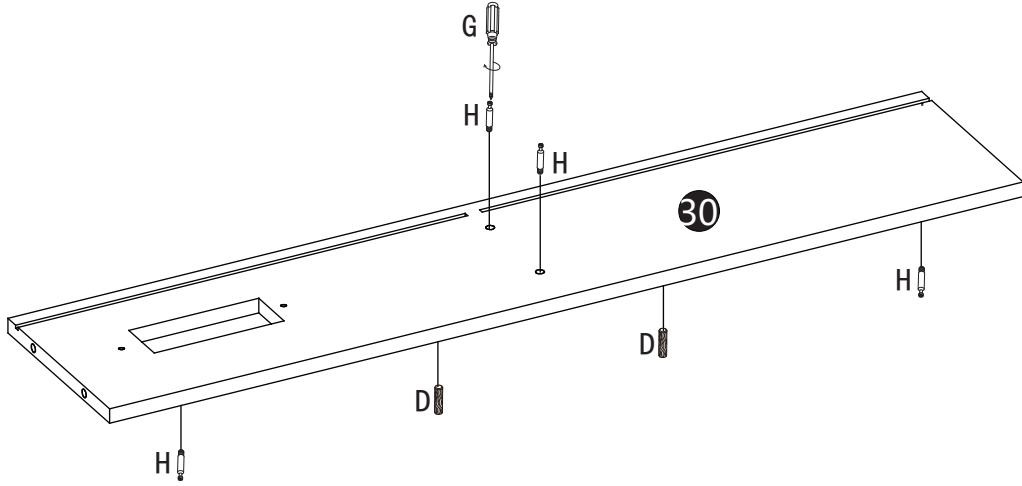

<b>N</b>		<b>E</b>	
	<b>Φ3.5*14mm(24pcs)</b>		<b>Φ3.5*30mm</b>

# SCHRITT 13:

<b>D</b> 	<b>G</b> 	<b>H</b> 	<b>J</b> 
2PCS	1PC	4PCS	4PCS



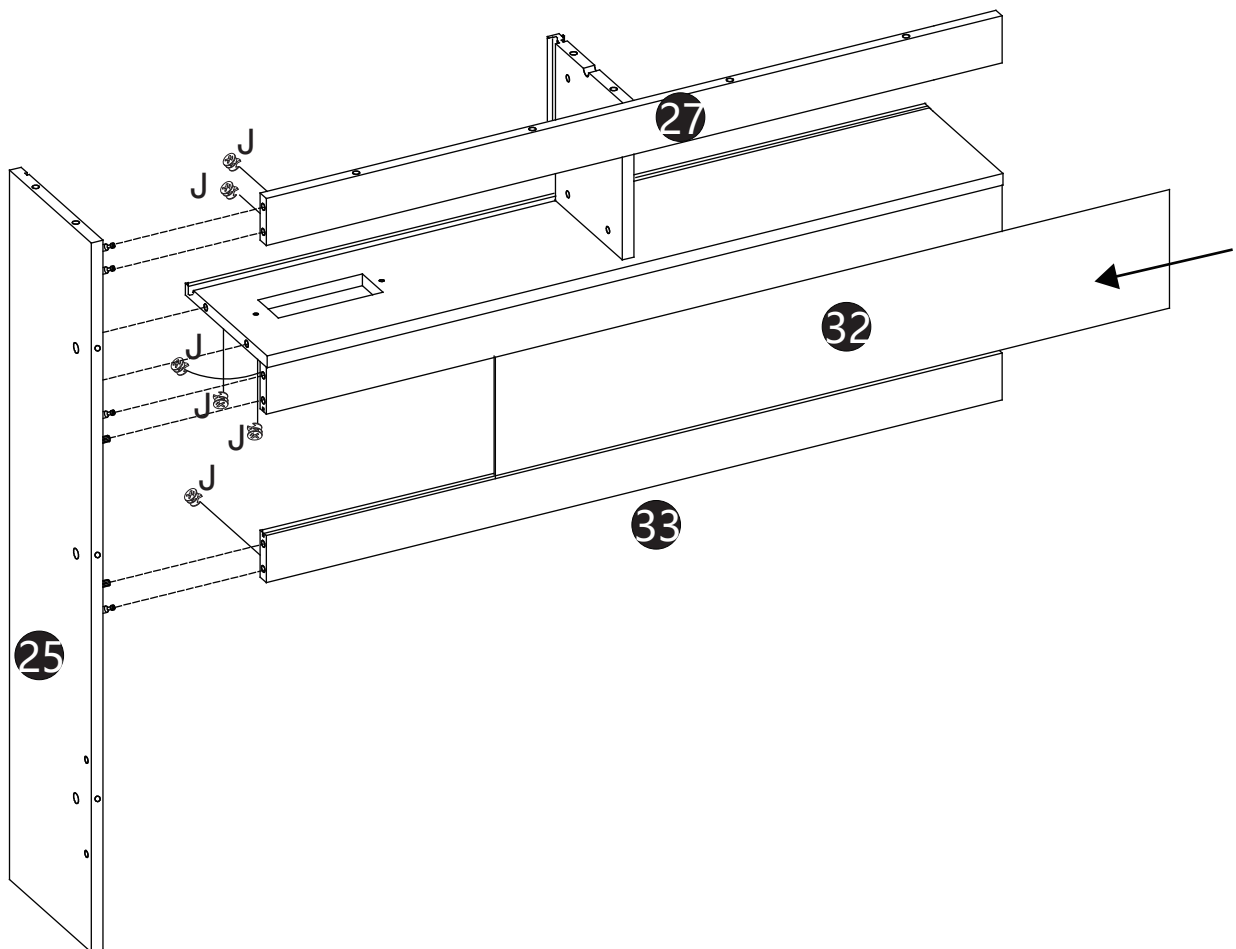
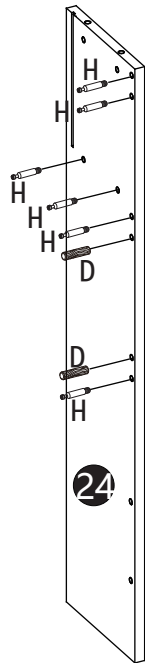
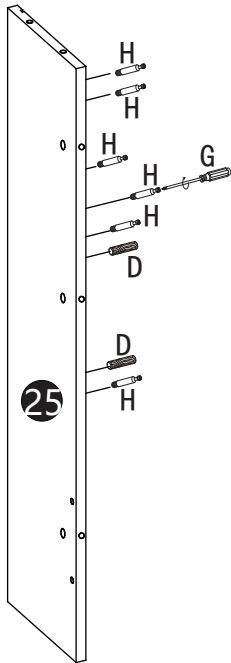

# SCHRITT 14:

<b>D</b>		<b>G</b>		<b>H</b>		<b>J</b>	
4PCS		1PC		12PCS		6PCS	







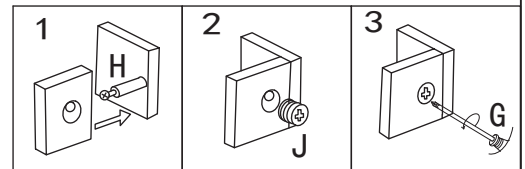
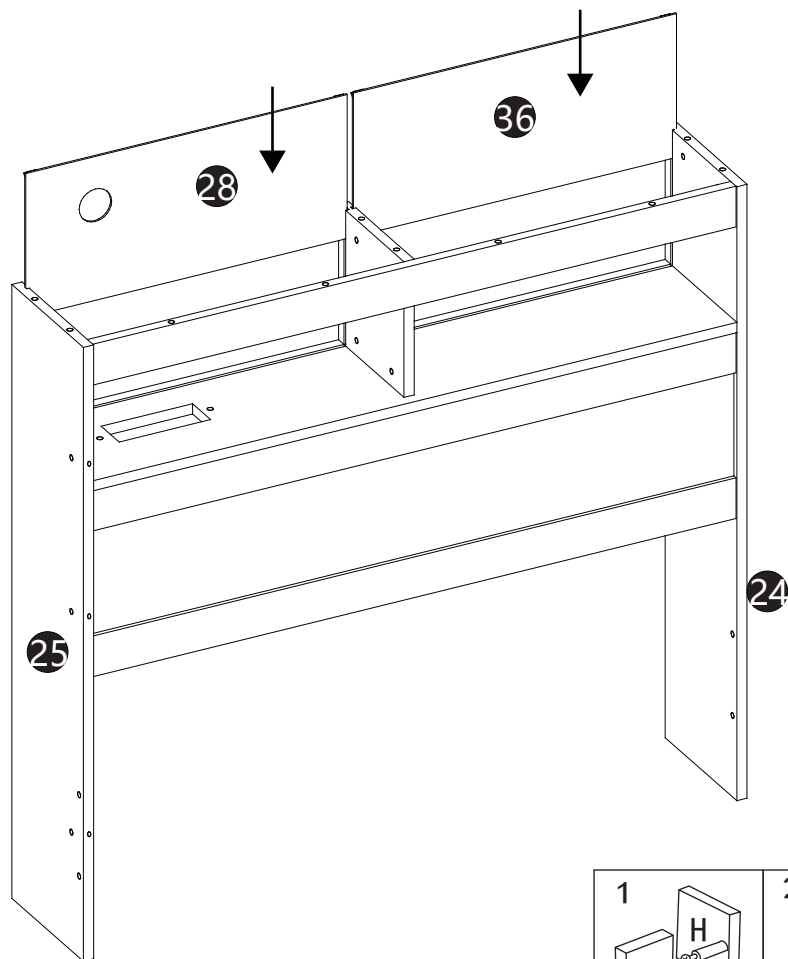
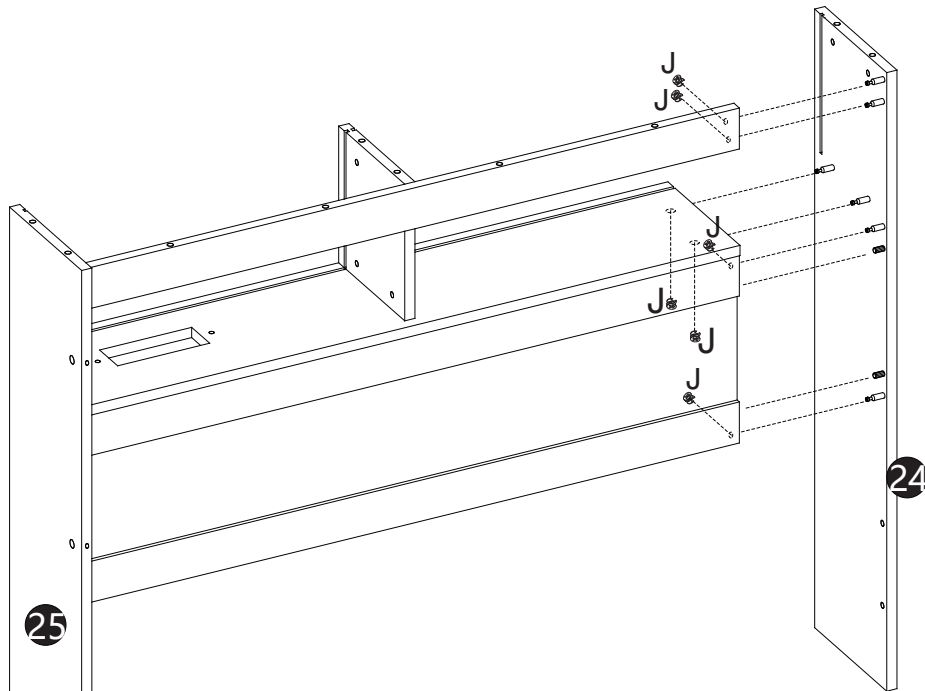

# SCHRITT 15:

<b>G</b>		<b>J</b>	
<b>1PC</b>		<b>6PCS</b>	





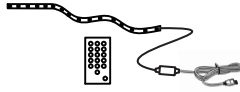

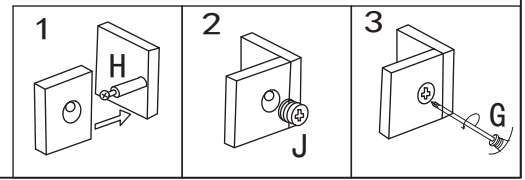
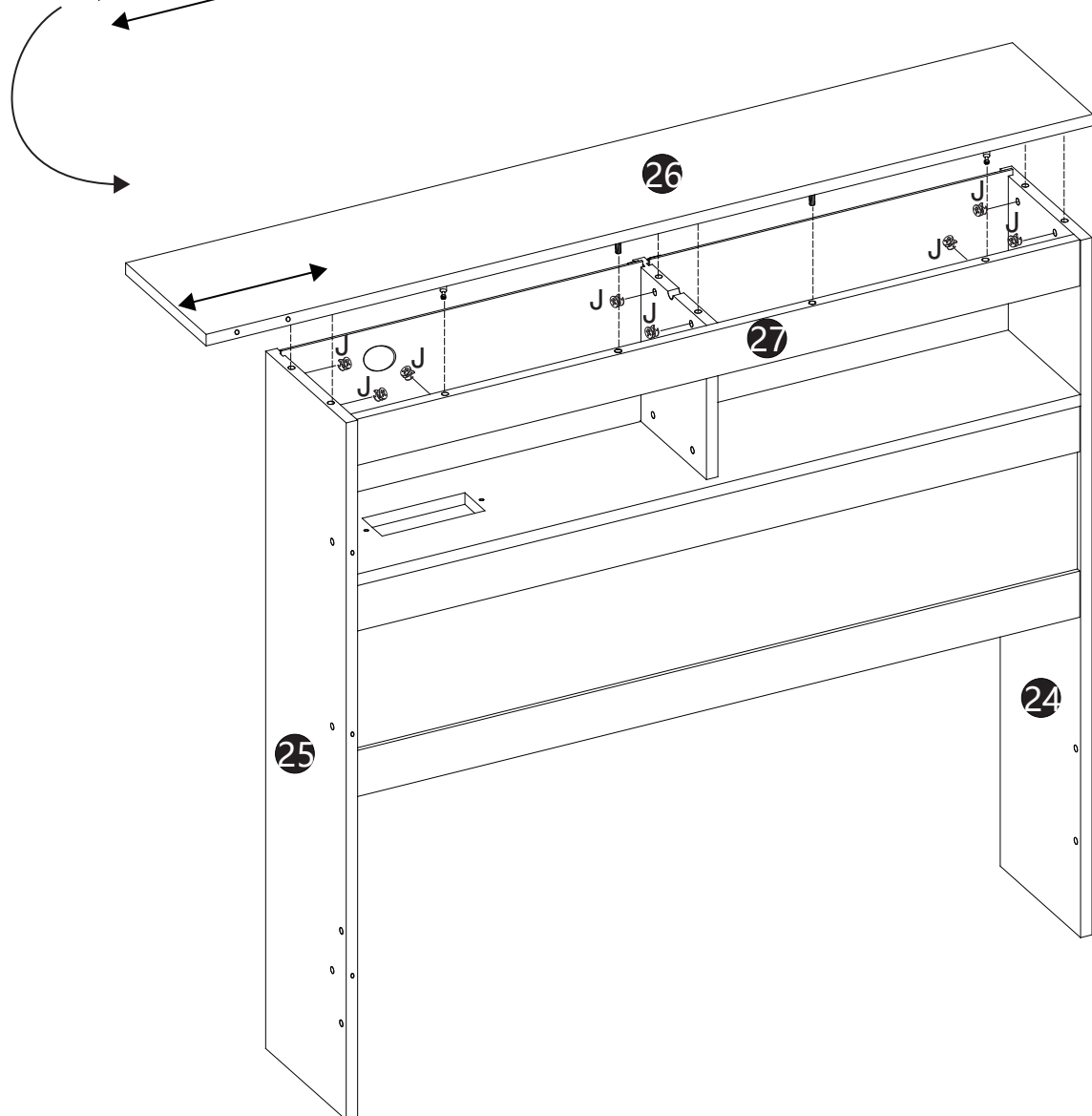
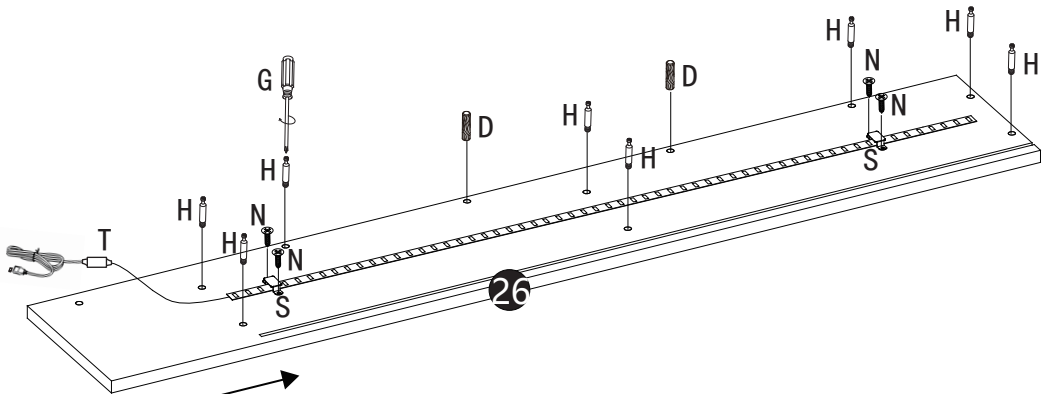
# SCHRITT 16:



<b>D</b>		<b>G</b>		<b>H</b>		<b>J</b>		<b>N</b>		<b>S</b>	
2PCS		1PC		8PCS		8PCS		4PCS		2PCS	
								<b>T</b>			
								1PC			



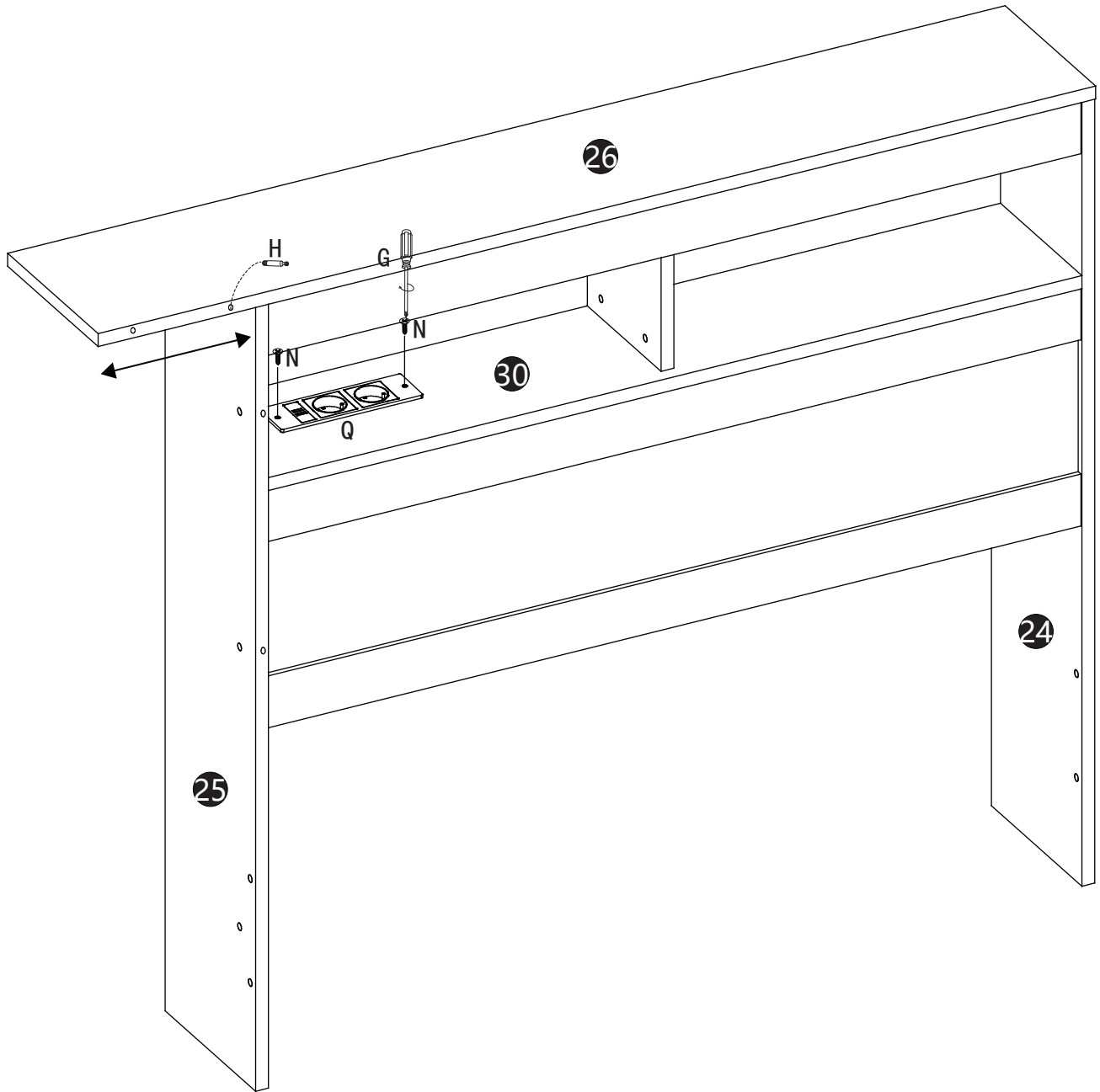

# SCHRITT 17:

<b>G</b>		<b>H</b>		<b>N</b>		<b>Q</b>	
<b>1PC</b>		<b>1PC</b>		<b>2PCS</b>		<b>1PC</b>	





<b>N</b>		<b>E</b>	
$\Phi 3.5 \times 14\text{mm} (2\text{pcs})$		$\Phi 3.5 \times 30\text{mm}$	

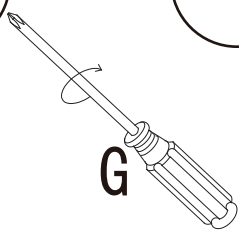
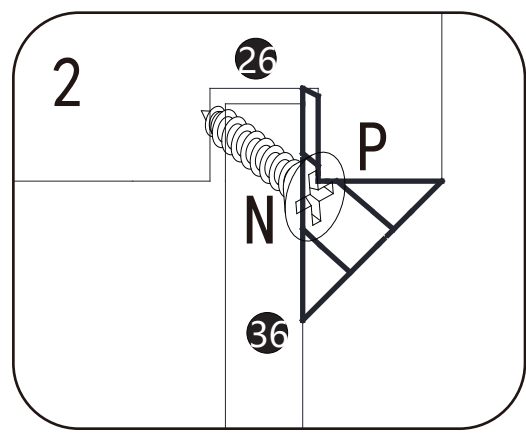
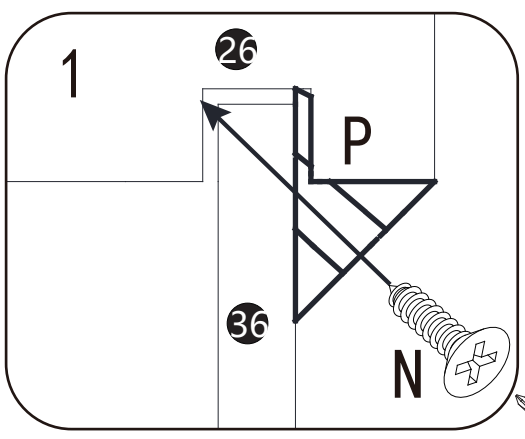
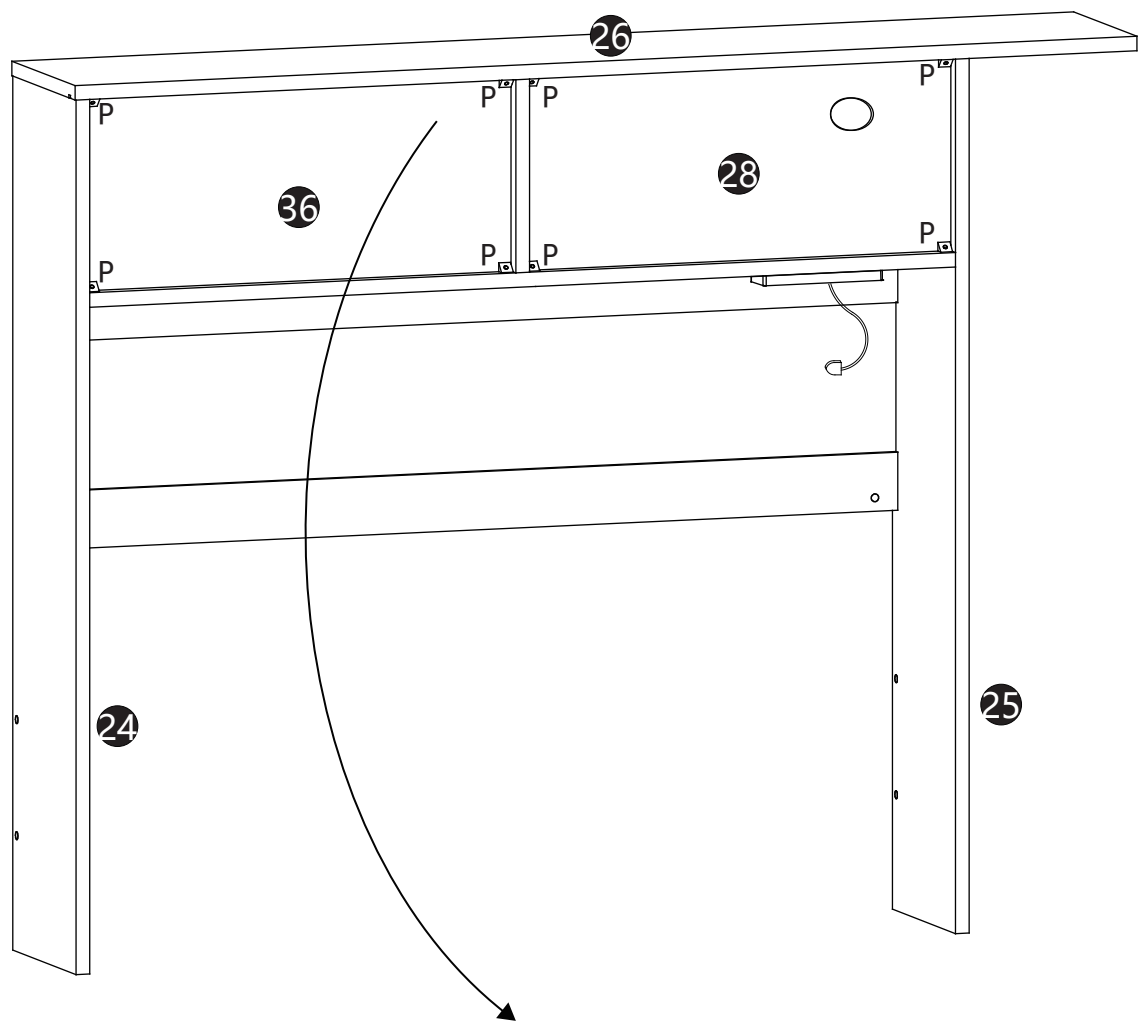

# SCHRITT 18:

<b>G</b>		<b>P</b>		<b>N</b>	
	<b>1 PC</b>		<b>8 PCS</b>		<b>8 PCS</b>





<b>N</b>		<b>E</b>	
	$\Phi 3.5 \times 14 \text{mm}$ (8pcs)		$\Phi 3.5 \times 30 \text{mm}$



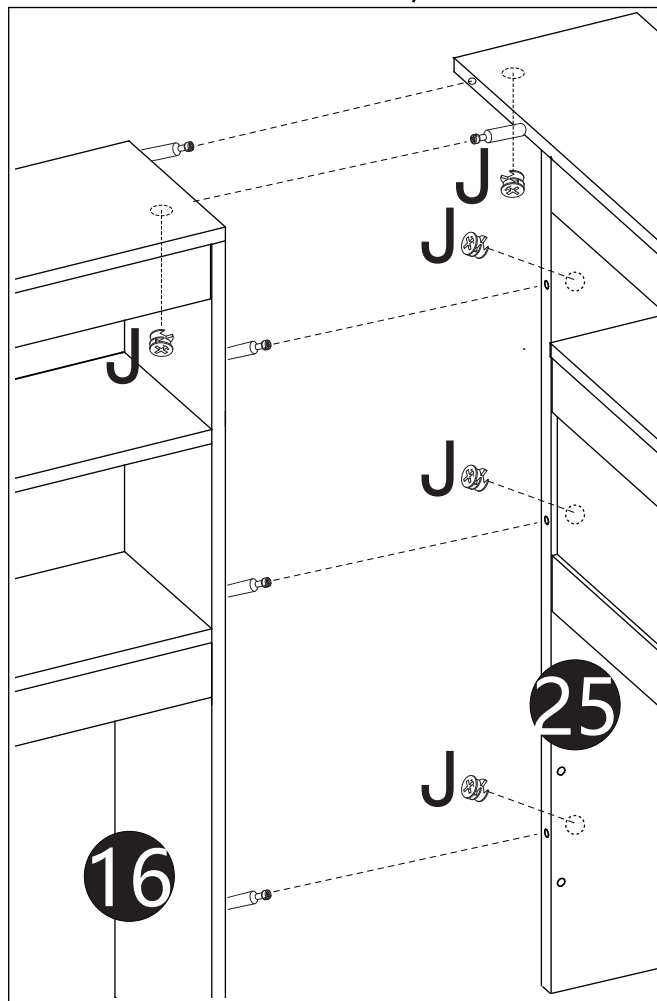
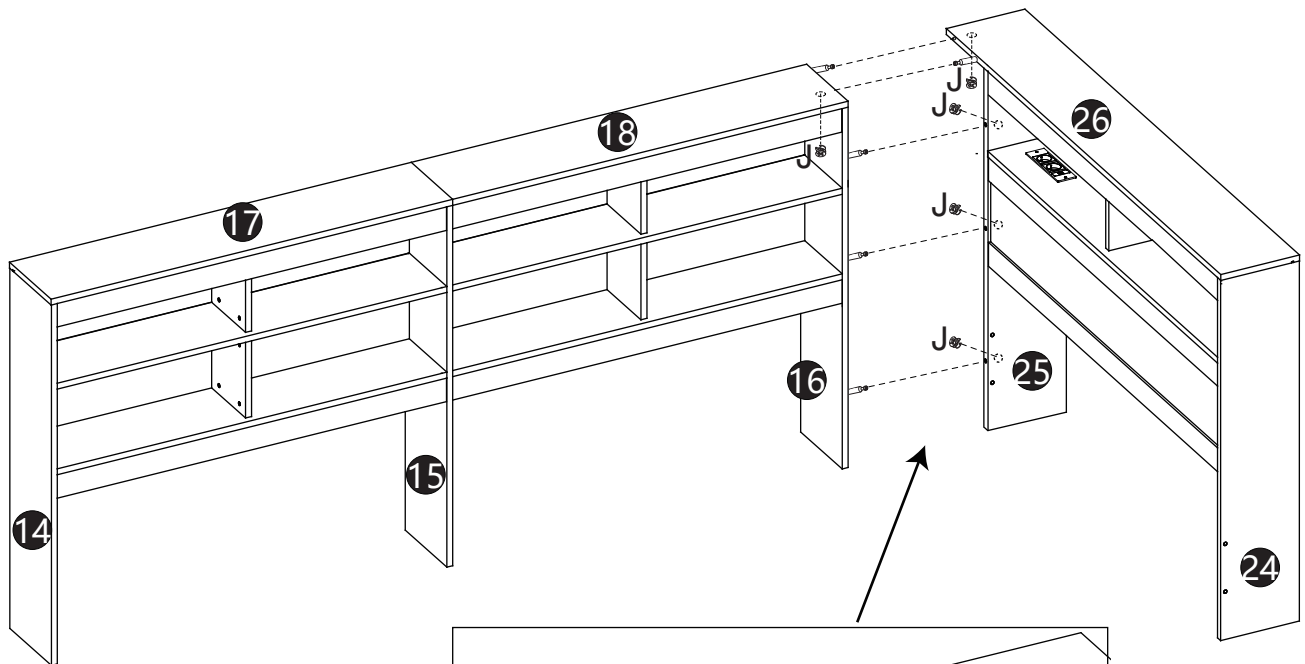



# SCHRITT 19:

<b>G</b>		<b>J</b>	
	<b>1PC</b>	<b>5PCS</b>	



<b>N</b>		<b>E</b>	
	<b>Φ3.5*14mm(16pcs)</b>		<b>Φ3.5*30mm</b>

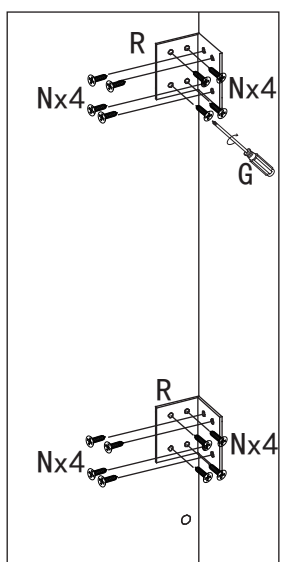
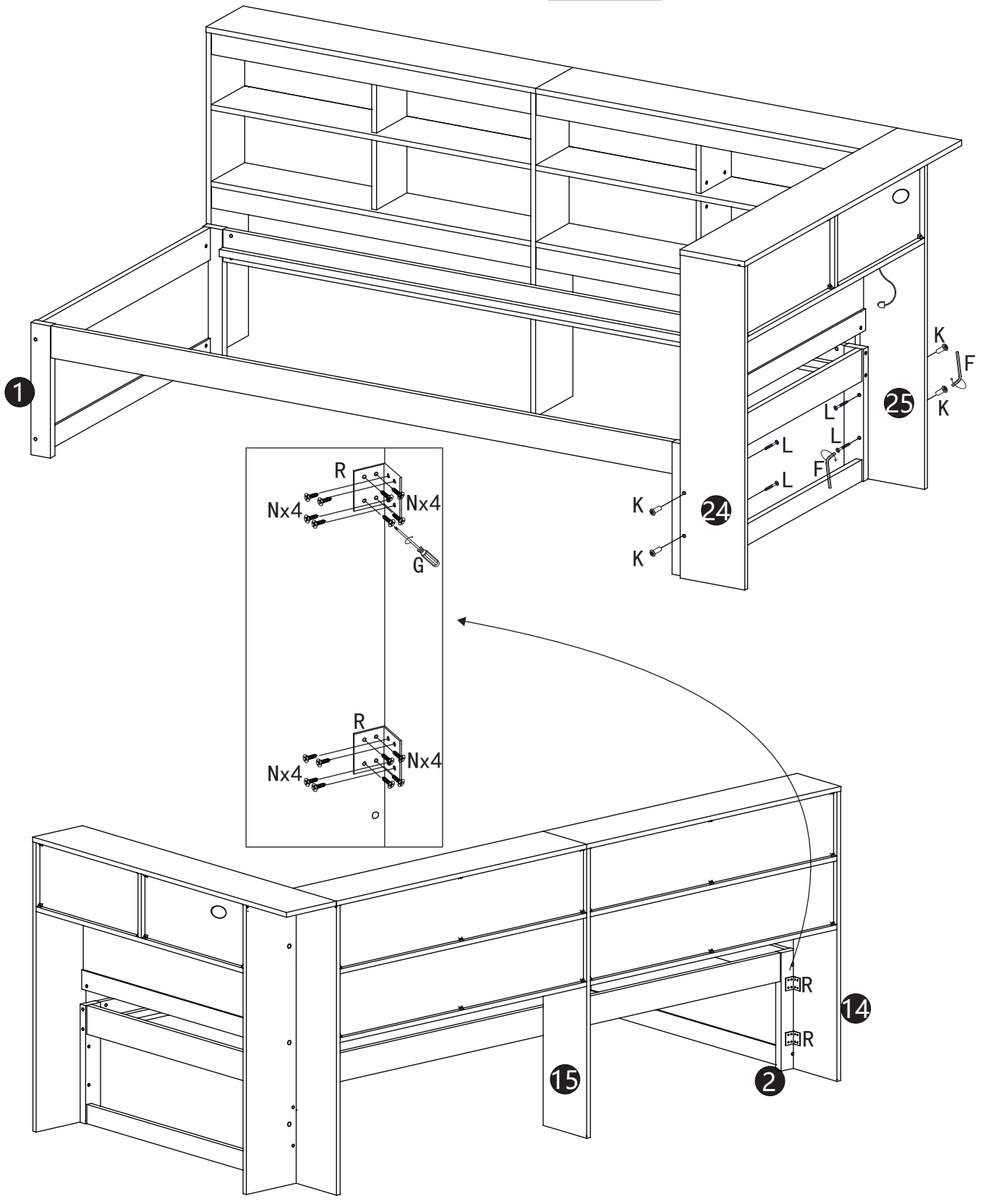

# SCHRITT 20:

<b>F</b> 	<b>G</b> 	<b>K</b> 	<b>L</b> 	<b>N</b> 	<b>R</b> 
2PCS	1PC	4PCS	4PCS	16PCS	2PCS





<b>B</b>  M6*100mm	<b>A</b>  M6*60mm	<b>L</b>  M6*35mm (4pcs)	<b>N</b>  Φ3.5*14mm (16pcs)	<b>E</b>  Φ3.5*30mm
---	--	---	--	--

# SCHRITT 21:

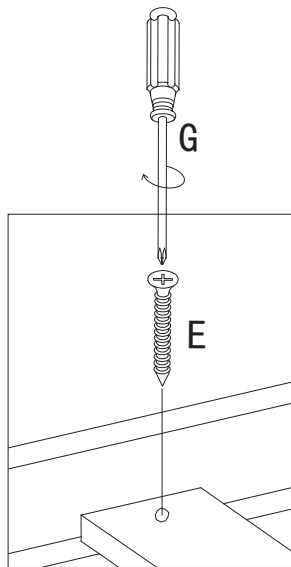
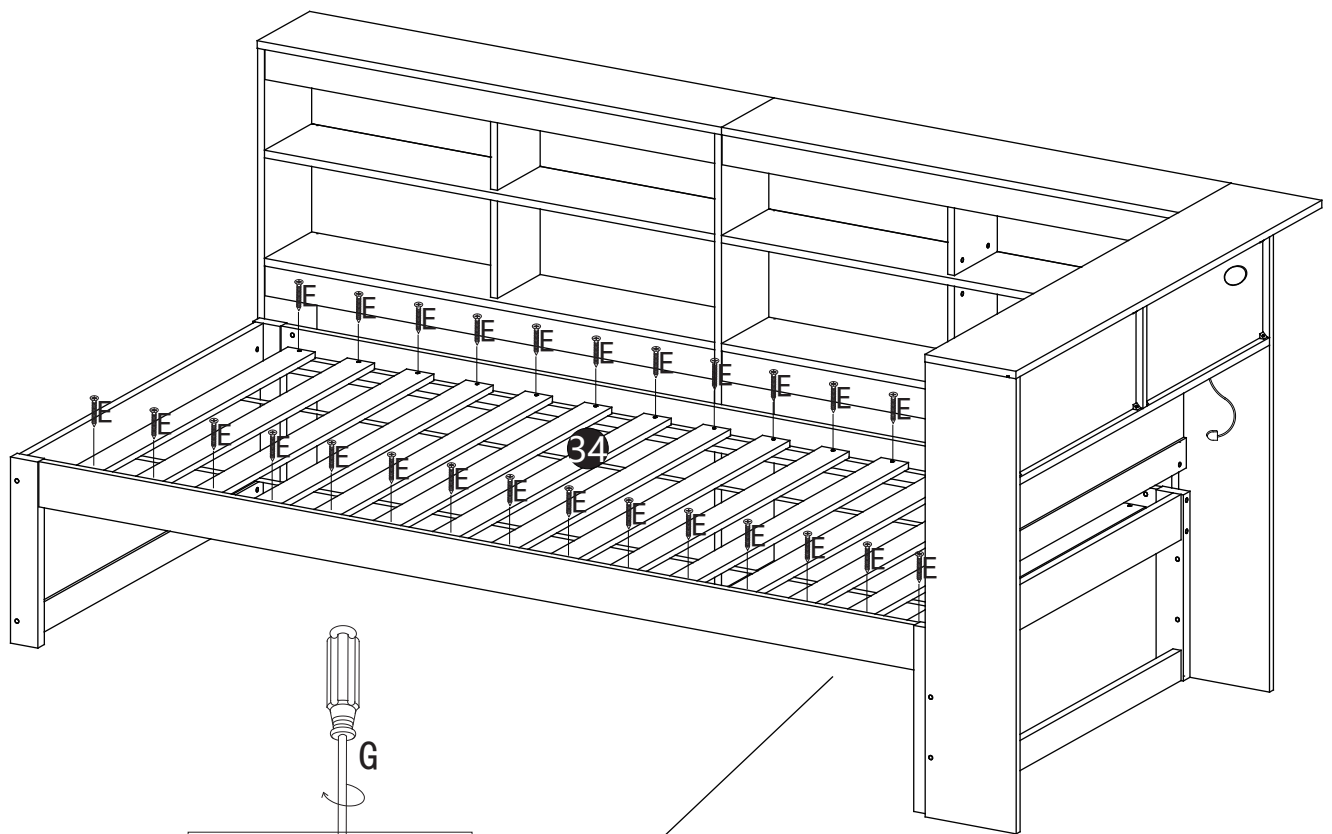





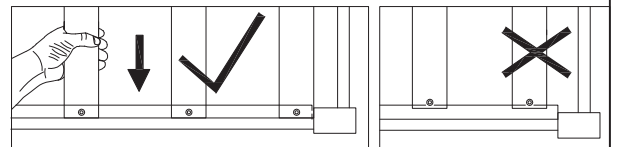

E		G	
30PCS		1PC	







	
<del>Φ3.5*14mm</del>	Φ3.5*30mm(30pcs)

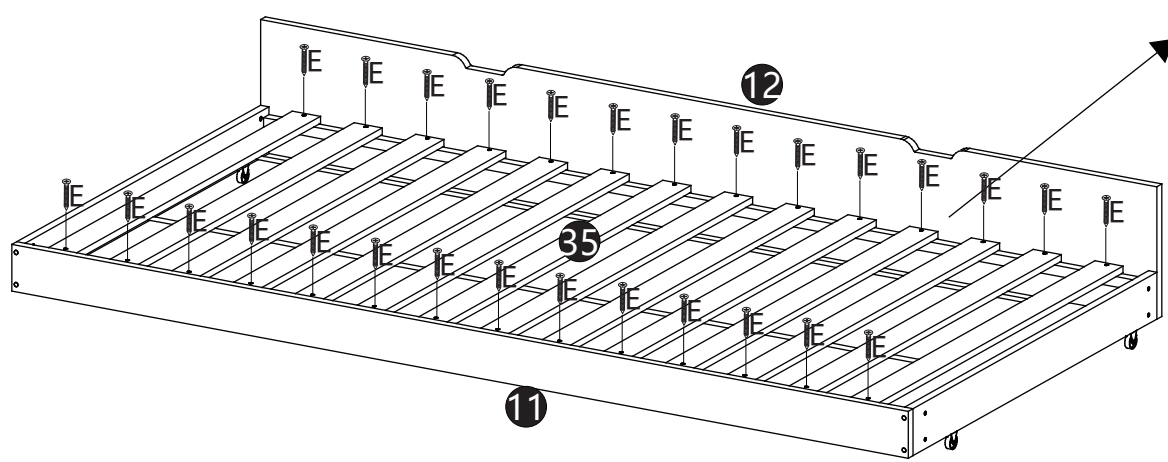
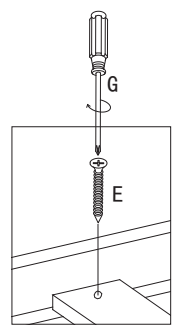
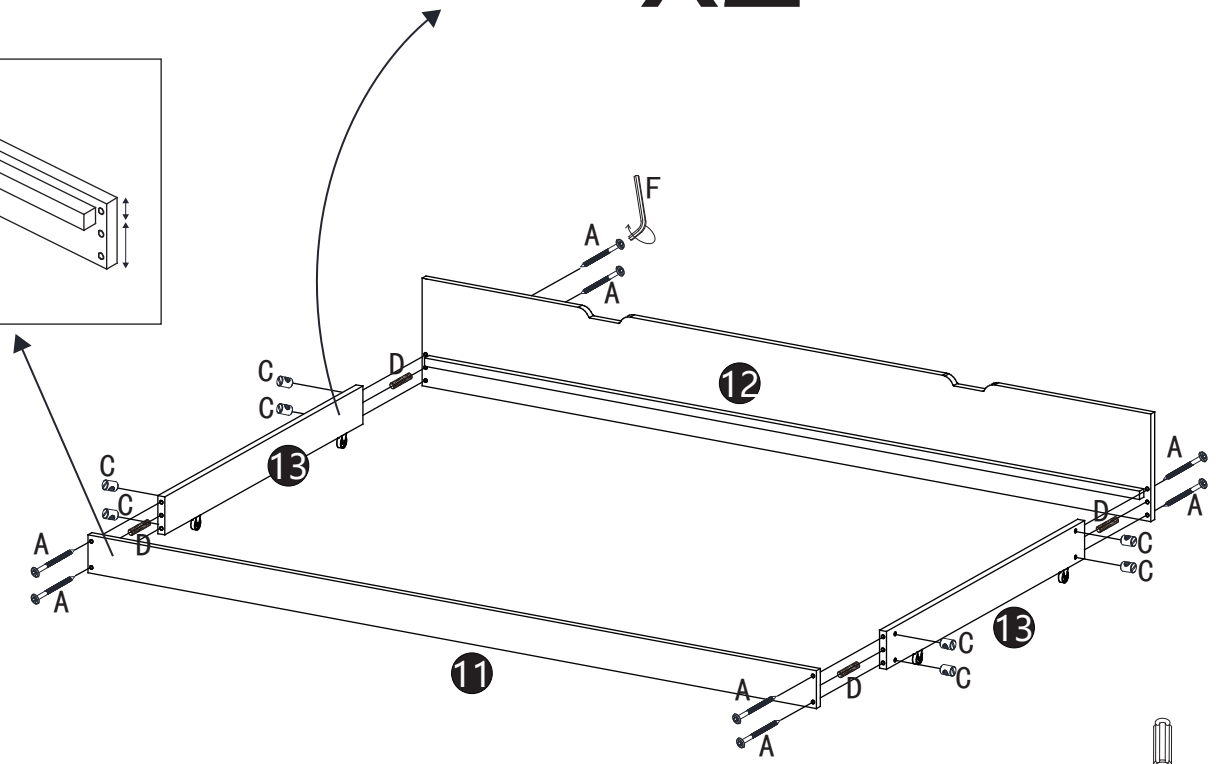
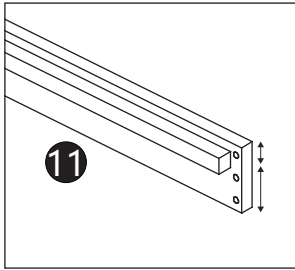
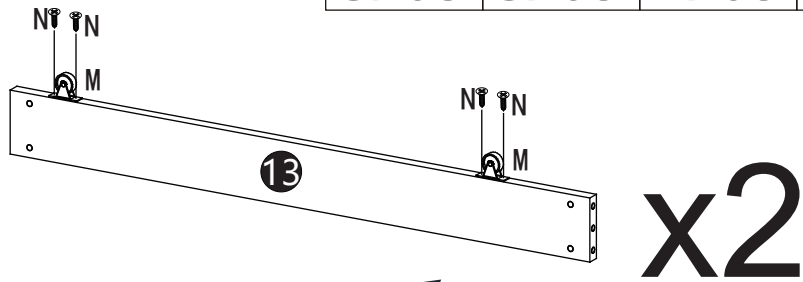

# SCHRITT 22:

<b>A</b> 	<b>C</b> 	<b>D</b> 	<b>E</b> 	<b>F</b> 	<b>G</b> 
8PCS	8PCS	4PCS	28PCS	1PC	1PC
				<b>M</b> 	<b>N</b> 
				4PCS	8PCS



<b>A</b> 	<b>B</b> 	<b>L</b> 
M6*60mm (8pcs)	M6*100mm	M6*35mm

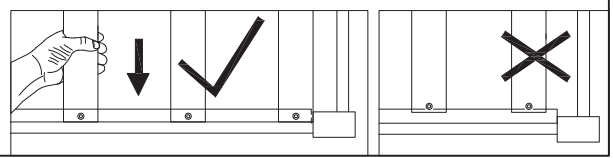

SCHRITT 23:

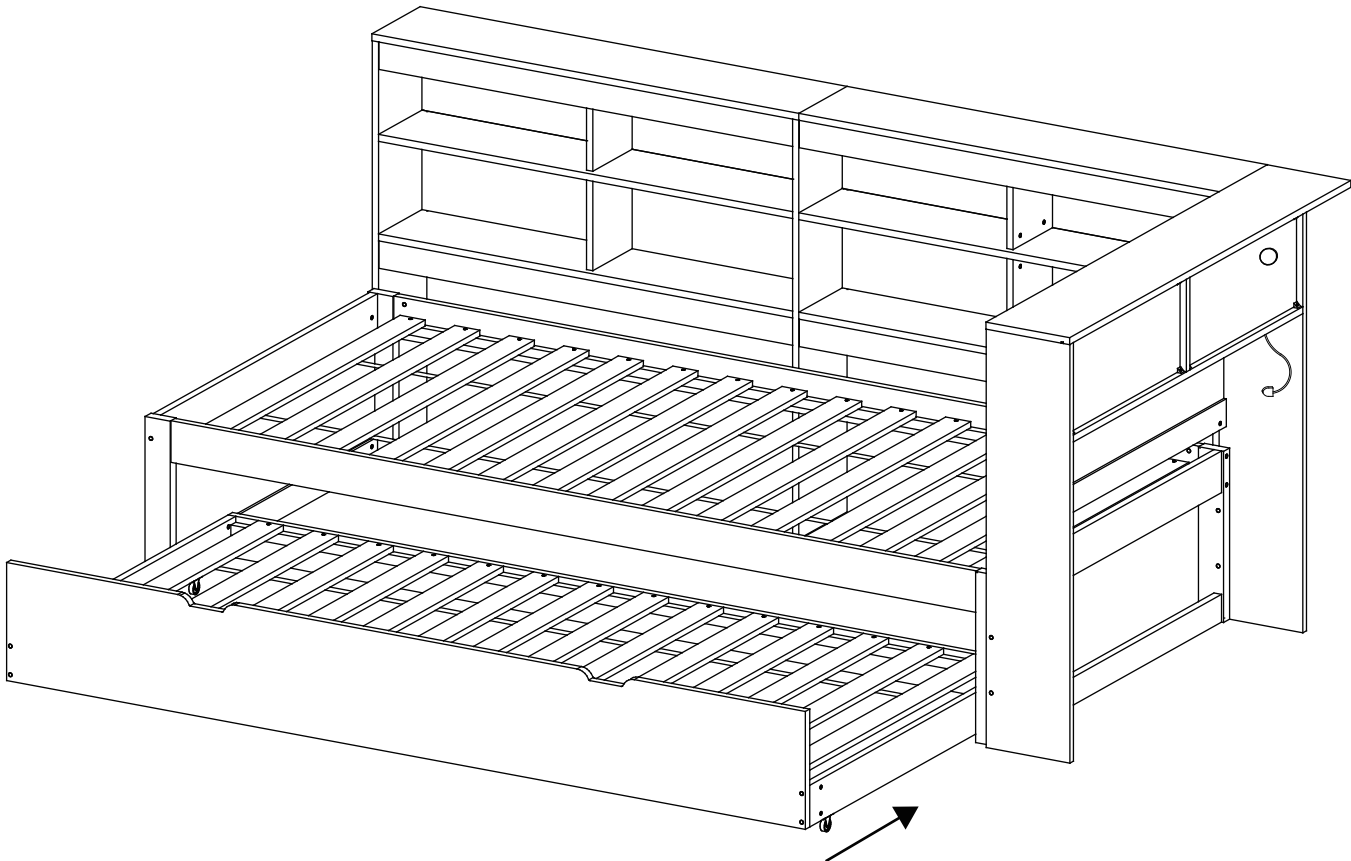

DE: Wenn Sie die Lichter nicht erfolgreich arbeiten lassen können, überprüfen Sie bitte die Folgendes:

1. Bitte überprüfen Sie die Fernbedienung. Sie müssen die Fernbedienung abreißen Plastikseptum vor Gebrauch.
2. Lassen Sie die Fernbedienung nicht zu weit vom Empfänger entfernt sein. Es gibt kein Hindernis zwischen ihnen.
3. Bitte beachten Sie, dass die Fernbedienung für den Transport keine Batterien enthält. Das Batteriemodell lautet: **CR2025**

FR: Si vous ne parvenez pas à faire fonctionner les lumières correctement, veuillez vérifier les points suivants

1. Veuillez vérifier la télécommande. Vous devez retirer le septum en plastique de la télécommande avant utilisation.
2. Ne laissez pas la télécommande être trop éloignée du récepteur. Il n'y a aucun obstacle entre eux.
3. Veuillez noter que la télécommande ne contient pas de piles pour le transport. Le modèle de batterie est: **CR2025**

UK: If you can't make the lights work successfully, please check the following:

1. Please check the remote control. You need to tear off the remote plastic septum before use.
2. Don't let the remote control be too far from the receiver. There is no obstacle between them.
3. Please note that the remote control does not contain batteries for transportation. The battery model is: **CR2025**

NOTE: The battery in the remote control requires you to purchase and install it yourself.

Model: CR2025 3. V

①



②



③

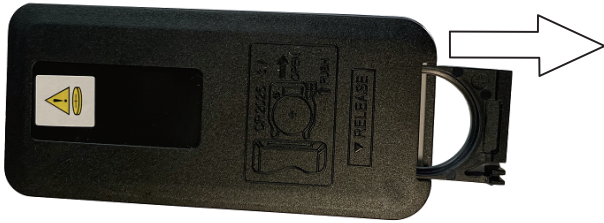

④



⑤



⑥



Modell : CR2025 3.V

⑦



⑧



# CERTIFICATE OF CONFORMITY

Certificate No.: KEYS23060207001RH-03

**Applicant** : GUANG TAI ENTERPRISE Co LTD  
**Address** : Rm 402, Bldg 4.No.2 Dapianmei Rd Dapianmei Village, Dalingshang  
DONGGUAN GUANGDONG  
**Manufacturer** : GUANG TAI ENTERPRISE Co LTD  
**Address** : Rm 402, Bldg 4.No.2 Dapianmei Rd Dapianmei Village, Dalingshang  
DONGGUAN GUANGDONG  
**Product** : USB power socket  
**Model No.** : JN02-00-22 JN02-00-23K JN02-00-21 JN02-00-23 JN02-00-23M  
JN00-00-04 JN00-00-03K JN02-00-22 JN00-00-04K JN02-00-23KM  
JN00-00-02 JN00-00-02K JN02-00-22M JN02-00-21M JN00-00-02KM  
JN00-00-03KM JN00-00-04M JN00-00-04KM

RoHS 2.0 Directive (EU) 2015/863 and (EU)2017/2102 amending Annex II to Directive 2011/65/EU.

The standard(s) used for showing compliance with the essential requirements:

**Applicable Standard(s)** IEC 62321-3-1: 2013  
IEC 62321-4:2013 +AMD1:2017  
IEC 62321-5:2013  
IEC 62321-6:2015  
IEC 62321-7-1:2015  
IEC 62321-7-2:2017  
IEC 62321-8:2017

The EUT described above has been consolidated by us and found in compliance with the council RoHS 2.0 Directive (EU) 2015/863 and (EU)2017/2102 amending Annex II to Directive 2011/65/EU.

The certificate applies to the tested sample above mentioned only and shall not imply an assessment of the whole production. It is only valid in connection with the test report number.

**KEYS23060207001RH-03**

# RoHS



Tony Qian/Approved Signatory  
Date: Jun. 06, 2023

Guangdong KEYS Testing Technology Co., Ltd.

Address: Room 206, Building 1, Huagu Technology Center, No. 6 Hehe Street, Hengkeng, Liaobu Town, Dongguan City, Guangdong Province

6/F., Building B, Chuangyigu Industrial Park, No.5, Hehe Street, Songxi Road, Hengkeng, Liaobu, Dongguan, Guangdong, China/523413

Tel:+ 86-0769-89798319 <http://www.keys-lab.com> E-mail: [info@keys-lab.com](mailto:info@keys-lab.com)



**SLG-CPC Testlaboratory Co., Ltd.**

## **VERIFICATION OF CONFORMITY**

**No.: 24050296C-C**

This verification is issued for

**GUANG TAI ENTERPRISE CO., LTD**

**Rm 402, Bldg 4.No.2 Dapianmei Rd., Dapianmei Village, Dalingshan DONGGUAN, Guangdong Sheng CN**

The product with designation of type

**Furniture Power Distribution Unit**

**Trade Mark: /**

**Model/s: JN02-00-21; JN00-00-04KM; JN00-00-02K; JN00-00-02KM; JN00-00-03KM; JN02-00-23K; JN00-00-04; JN02-00-23; JN02-00-22M; JN02-00-23M; JN00-00-04K; JN00-00-03K; JN02-00-23KM; JN02-00-22; JN02-00-24K; JN02-00-24; JN02-00-24M; JN02-00-24KM**

This is to declare that the technical file of the products complies the essential requirements of below European Directives:

**EMC Directive 2014/30/EU**

Reference standards:

**EN IEC 55014-1:2021**

**EN IEC 55014-2:2021**

**EN IEC 61000-3-2:2019+A1:2021**

**EN 61000-3-3:2013/A2:2021/AC:2022-01**

This verification is based on the following file

**90340-24-71-24-PP002**

and is valid only if the product is manufactured in accordance with the corresponding tested sample.

This verification is the result of tests carried out on one sample and does not represent the serial production of this product.

The CE mark as shown can be used, under the responsibility of the manufacturer, after completion of an EC Declaration of Conformity and compliance with all relevant EC Directives.

This verification of conformity loses its validity in the following cases:

- if the reference standards and/or EC Directives are modified;
- if any modifications are made to the model/s without our approval.



May. 13, 2024

(Date)

*Jason gao*

Jason Gao  
Lab Manager



SLG-CPC Testlaboratory Dongguan Co., Ltd.

## VERIFICATION OF CONFORMITY

No.: 24050295C-C

This verification is issued for

**GUANG TAI ENTERPRISE CO LTD**

Rm 402, Bldg 4, No.2 Dapianmei Rd., Dapianmei Village, Dalingshan, DONGGUAN, Guangdong, China

The product with designation of type

**Furniture Power Distribution Unit**

**Trade Mark: N/A**

**Model/s: JN00-00-02K; JN00-00-02KM; JN00-00-03K; JN00-00-03KM; JN00-00-04; JN00-00-04K; JN00-00-04KM; JN02-00-21; JN02-00-22; JN02-00-22M; JN02-00-23; JN02-00-23K; JN02-00-23M; JN02-00-23KM; JN02-00-24K; JN02-00-24; JN02-00-24M; JN02-00-24KM**

This is to declare that the technical file of the products complies the essential requirements of below European Directives:

**Low Voltage Directive 2014/35/EU;**

Reference standards:

**IEC 60884-2-7:2011+ AMD1:2013  
IEC 60884-1:2002 + AMD1:2006  
IEC 62368-1:2018 (EN IEC 62368-1:2020 + A11:2020)**

This verification is based on the following file

**90340-24-70-24-PP001**

And is valid only if the product is manufactured in accordance with the corresponding tested sample.

This verification is the result of tests carried out on one sample and does not represent the serial production of this product.

The CE mark as show can be used, under the responsibility of the manufacturer, after completion of an EC Declaration of Conformity and compliance with all relevant EC Directives.

This verification of conformity loses its validity in the following cases:

- if the reference standards and/or EC Directives are modified;
- if any modifications are made to the model/s without our approval.



2024-05-11

(Date)

Owen Zhan  
Technical Director



Shenzhen POCE Technology Co.,Ltd.

H Building, Hongfa Science and Technology Park,  
Tangtou, Shiyan, Bao'an District, Shenzhen, China

## CERTIFICATE OF CONFORMITY

**Certificate No** : POCE220829292TCE  
**Applicant** : Shenzhen Xuxing Technology Co.,Ltd  
**Address** : Floor 3, Building C, Huaze Hi-Tech Industrial Park, No.108 Zhushi Road, Shiyan Street, Bao'an District, Shenzhen  
**Manufacturer** : Shenzhen Xuxing Technology Co.,Ltd  
**Address** : Floor 3, Building C, Huaze Hi-Tech Industrial Park, No.108 Zhushi Road, Shiyan Street, Bao'an District, Shenzhen  
**Product** : Led lights bring

**Trade Name** : 

**Model(s)** : XX5050-RGB-60D, XX5050-RGB-30D, XX5050-RGB-72D, XX5050-RGB-96D, XX5050-RGB-120D, CLB1-2835-1, CLB1-2835-0, XX2835-W/Y-120D, XX2835-W/Y-60D, XX2835-W/Y-240D, XX2835-W/Y-238D, XX2835-W/Y-168D, XX2835-W/Y-224D, XX2835-W/Y-118D, XX2835-W/Y-162D, XX2835-W/Y-124D, XX2835-W/Y-170D, XX2835-60D, XX2835-120D, XX2835-150D, XX2835-180D

**Test Report No** : POCE220829292TRE  
**Test Standards** : EN IEC 55015:2019/A11:2020  
EN 61547:2009  
EN IEC 61000-3-2:2019/A1:2021  
EN 61000-3-3:2013/A2:2019

The EUT described above has been tested by us with the listed standards and found in compliance with the council EMC Directive 2014/30/EU. It is possible to use CE marking to demonstrate the compliance with this EMC Directive.



  
For Chief Executive / Tom Chen  
Date: Sep. 02, 2022  

This certificate of conformity is based on a single evaluation of the submitted sample(s) of the above mentioned product. It does not imply an assessment of the whole production and other relevant directives have to be observed.



扫一扫关注



扫码查证书



Shenzhen POCE Technology Co.,Ltd.

H Building, Hongfa Science and Technology Park,  
Tangtou, Shiyan, Bao'an District, Shenzhen, China

## CERTIFICATE OF CONFORMITY

**Certificate No.** : POCE220829293QCR  
**Applicant** : Shenzhen Xuxing Technology Co., Ltd  
**Address** : Floor 3, Building C, Huaze Hi-Tech Industrial Park, No. 108  
Zhushi Road, Shiyan Street, Bao'an District, Shenzhen  
**Manufacturer** : Shenzhen Xuxing Technology Co., Ltd  
**Address** : Floor 3, Building C, Huaze Hi-Tech Industrial Park, No. 108  
Zhushi Road, Shiyan Street, Bao'an District, Shenzhen  
**Product** : Led lights bring  
**Trade Name** :   
**Model(s)** : XX5050-RGB-60D, XX5050-RGB-30D, XX5050-RGB-72D,  
XX5050-RGB-96D, XX5050-RGB-120D, CLB1-2835-1,  
CLB1-2835-0, XX2835-W/Y-120D, XX2835-W/Y-60D,  
XX2835-W/Y-240D, XX2835-W/Y-238D, XX2835-W/Y-168D,  
XX2835-W/Y-224D, XX2835-W/Y-118D, XX2835-W/Y-162D,  
XX2835-W/Y-124D, XX2835-W/Y-170D, XX2835-60D,  
XX2835-120D, XX2835-150D, XX2835-180D  
**Test Report No.** : POCE220829293QRR  
**Test Standards** : IEC 62321-3-1:2013; IEC 62321-4:2013+A1:2017;  
IEC 62321-5:2013; IEC 62321-6:2015; IEC 62321-7-1:2015;  
IEC 62321-7-2:2017; IEC 62321-8:2017

The EUT described above has been tested by us with the listed standards and found in compliance with the council **RoHS Directive(EU) 2015/863 amending Annex II to Directive 2011/65/EU**. It is possible to use **CE** marking to demonstrate the compliance with this **RoHS** Directive.



  
.....  
For Chief Executive / Jerry Yang  
Date: Sep. 02, 2022

This certificate of conformity is based on a single evaluation of the submitted sample(s) of the above mentioned product. It does not imply an assessment of the whole production and other relevant directives have to be observed.



扫一扫关注



扫码查证书

Web: <http://www.poce-cert.com> Tel: +86-755-29113252 E-mail: [service@poce-cert.com](mailto:service@poce-cert.com)