

Montageanleitung | Instructions de montage
Assembly Instructions | Instrucciones de montaje
SKU NUMBER:W5236P428582/ W5236P428583
W5236P428584/ W5236P428585

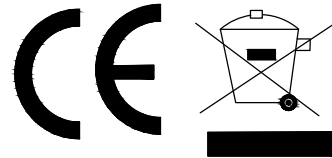
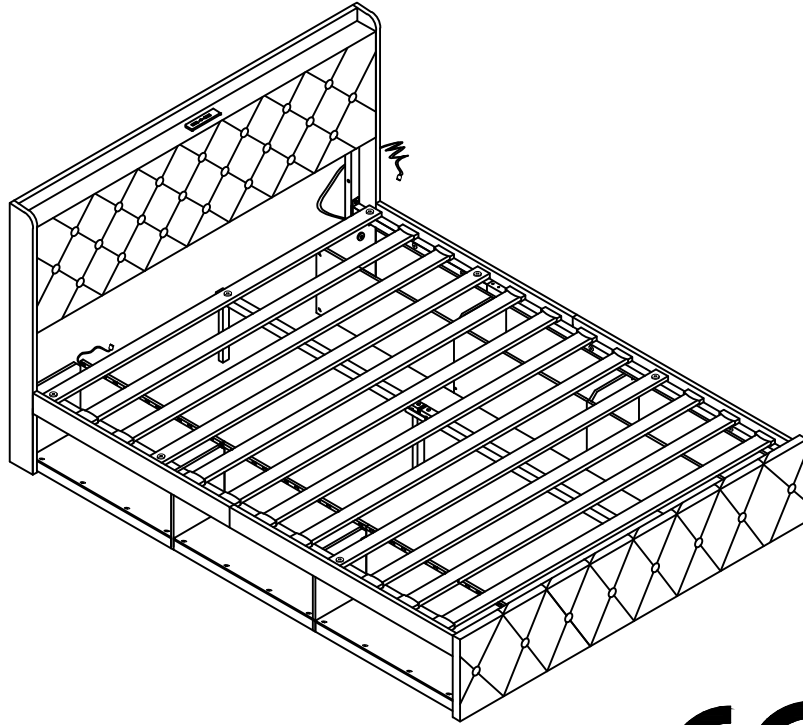

EN

This set comes in 2 boxes.If you do not receive a full set of 2 boxes, please contact our customer service.

DE

Dieses Set wird in 2 Schachteln geliefert.Wenn Sie nicht ein komplettes Set von 2 Boxen erhalten, kontaktieren Sie bitte unseren Kundenservice.

FR

Ce set est livré en 2 bolîtes.Si vous ne recevez pas un jeu complet de 2 bolîtes, veuillez contacter notre service clientèle.

IT

Questo set è composto da 2 scatole. Se non ricevi il set completo di 2 scatole, ti preghiamo di contattare il nostro servizio clienti .

ES

Este juego viene en 2 cajas. Si no recibe el juego completo de 2 cajas, póngase en contacto con nuestro servicio de atención al cliente.

English

IMPORTANT FOR GAS LIFT BEDS&MAINTAINCE

- Please place the mattress on top of the bed frame.
- Please do not pull on the strap handles.
-
- Periodically check all screw & fixings to ensure they are secure.
- When moving your product, carefully lift into place.
- Wipe clean with a slightly damp cloth- please do not use abrasive chemicals or bleach.
- Do NOT allow children to operate the lift mechanism.
- Do NOT allow children near the lift base when operating the mechanism.
- Do NOT stand inside the bed or the internal storage base.
- Do NOT overload the internal storage base.
- DO NOT jump on the product or any of its parts.

Deutsch

WICHTIG FÜR GASLIFT-BETTEN&WARTUNG

- Bitte legen Sie die Matratze oben auf den Bettrahmen.
- Bitte ziehen Sie nicht an den Gurtgriffen.
-
- Überprüfen Sie regelmäßig alle Schrauben und Befestigungen, um sicherzustellen, dass sie sicher sind.
- Wenn Sie Ihr Produkt bewegen, heben Sie es vorsichtig an seinen Platz.
- Mit einem leicht feuchten Tuch abwischen - bitte keine scheuernden Chemikalien oder Bleichmittel verwenden.
- Erlauben Sie Kindern NICHT, den Hebemechanismus zu bedienen.
- Lassen Sie Kinder NICHT in die Nähe des Liftsockels, wenn Sie den Mechanismus bedienen.
- Stellen Sie sich NICHT in das Bett oder in die Innenablage.
- Überlasten Sie den internen Liftsockel NICHT.
- Springen Sie NICHT auf das Produkt oder eines seiner Teile.

Français

IMPORTANT POUR LES LITS À RELEVAGE DE GAZ&MAINTENANCE

- Veuillez placer le matelas sur le dessus du cadre de lit.
- Ne tirez pas sur les poignées de la sangle.
-
- Vérifiez régulièrement que toutes les vis et fixations sont bien en place.
- Lorsque vous déplacez votre produit, soulevez-le avec précaution pour le mettre en place.
- Nettoyez avec un chiffon légèrement humide - n'utilisez pas de produits chimiques abrasifs ou d'eau de Javel.
- Ne laissez pas les enfants utiliser le mécanisme de levage.
- Ne laissez pas les enfants s'approcher de la base de levage lorsqu'ils actionnent le mécanisme.
- Ne vous tenez PAS à l'intérieur du lit ou de la base de stockage interne.
- Ne surchargez pas la base de stockage interne.
- Ne pas sauter sur le produit ou l'une de ses parties.

Italiano

IMPORTANTE PER I LETTI CON SOLLEVAMENTO A GAS E LA MANUTENZIONE



- Posizionare il materasso sopra la struttura del letto.
- Non tirare le maniglie della cinghia.
-
- Controllare periodicamente tutte le viti e i fissaggi per assicurarsi che siano saldi.
- Quando si sposta il prodotto, sollevarlo con cautela.
- Pulire con un panno leggermente umido, senza usare prodotti chimici abrasivi o candeggina.
- NON permettere ai bambini di azionare il meccanismo di sollevamento.
- NON permettere ai bambini di avvicinarsi alla base di sollevamento quando si aziona il meccanismo.
- NON sostare all'interno del letto o della base di contenimento interna.
- NON sovraccaricare la base di contenimento interna.
- NON saltare sul prodotto o sulle sue parti.

Español

IMPORTANTE PARA LAS CAMAS ELEVADORAS DE GAS&MANTENIMIENTO

- Coloque el colchón sobre el somier.
- No tire de las asas de la correa.
-
- Compruebe periódicamente que todos los tornillos y fijaciones estén bien sujetos.
- Al mover el producto, levántelo con cuidado para colocarlo en su sitio.
- Limpie con un paño ligeramente humedecido; no utilice productos químicos abrasivos ni lejía.
- NO permita que los niños accionen el mecanismo de elevación.
- NO permita que los niños se acerquen a la base elevadora cuando accionen el mecanismo.
- NO se ponga de pie dentro de la cama o de la base de almacenamiento interna.
- NO sobrecargue el somier.
- NO salte sobre el producto ni sobre ninguna de sus piezas.

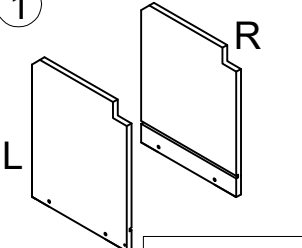
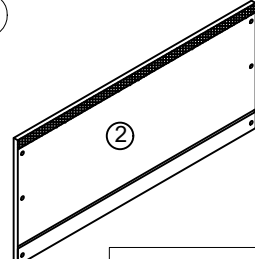
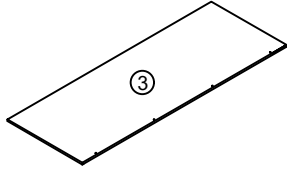
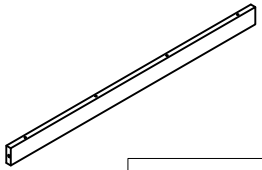
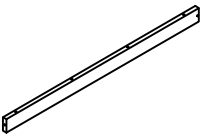
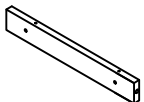
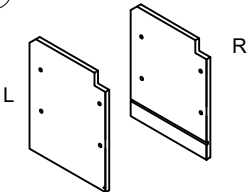
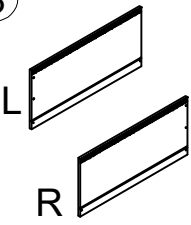
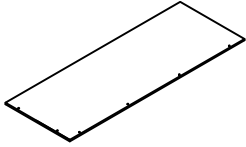
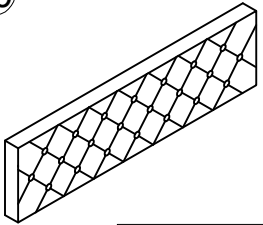
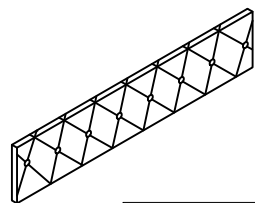
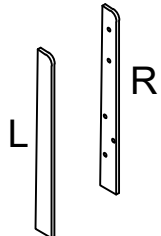
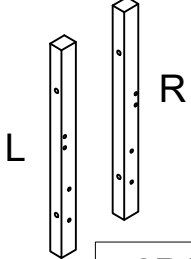
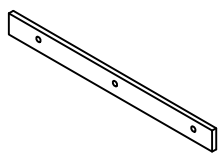
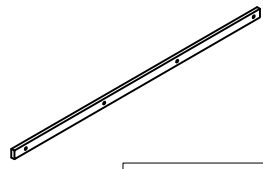
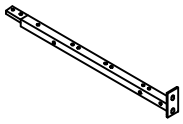
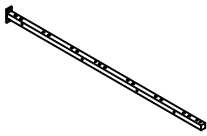
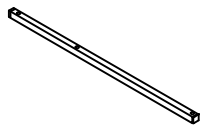
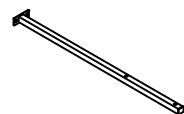
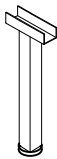

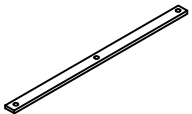
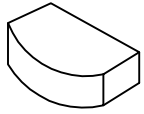



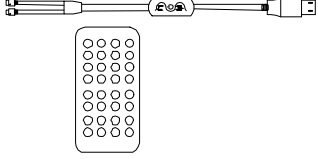
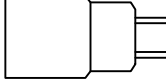

PARTS LIST

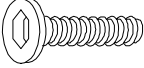
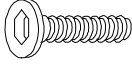
<p>①</p>  <p>4PCS</p>	<p>②</p>  <p>2PC</p>	<p>③</p>  <p>2PCS</p>	<p>④</p>  <p>2PCS</p>
<p>⑤</p>  <p>4PCS</p>	<p>⑥</p>  <p>4PCS</p>	<p>⑦</p>  <p>4PCS</p>	<p>⑧</p>  <p>4PCS</p>
<p>⑨</p>  <p>4PCS</p>	<p>⑩</p>  <p>1PC</p>	<p>⑪</p>  <p>1PC</p>	<p>⑫</p>  <p>2PCS</p>
<p>⑬</p>  <p>2PCS</p>	<p>⑭</p>  <p>4PCS</p>	<p>⑮</p>  <p>1PC</p>	<p>⑯</p>  <p>2PCS</p>
<p>⑰</p>  <p>2PCS</p>	<p>⑱</p>  <p>1PC</p>	<p>⑲</p>  <p>1PC</p>	<p>⑳</p>  <p>1PC</p>
<p>㉑</p>  <p>1PC</p>	<p>㉒</p>  <p>9PCS</p>	<p>㉓</p>  <p>3PCS</p>	<p>㉔</p>  <p>18PCS</p>

PARTS LIST

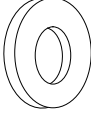
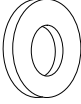
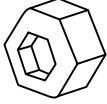
<p>25</p> 	<p>26</p> 	<p>27</p> 	
2PCS	1SET	1PC	

HARDWARE LIST

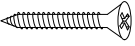
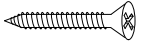
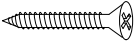
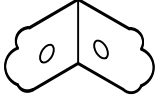
<p>A</p> 	<p>B</p> 	<p>C</p> 	<p>D</p> 
5/16"*60mm 4PCS	5/16"*50mm 13+1PCS	5/16"*35mm 16+2PCS	5/16"*25mm 22+2PCS
<p>E</p> 	<p>F</p> 	<p>G</p> 	<p>H</p> 
1/4"*50mm 16+2PCS	5/16"*13mm 55+2PCS	5/16"*19mm 63+2PCS	1/4 *16mm 16+2PCS
<p>I</p> 	<p>J</p> 	<p>K</p> 	<p>L</p> 
5/16" 8+1PCS	5/16"*100mm 1PC	1/4*100mm 1PC	5/16" 1PC
<p>M</p> 	<p>N</p> 	<p>O</p> 	<p>P</p> 
M4*30mm 40+2PCS	M4*20mm 32+2PCS	M3*12mm 8+1PCS	4 PCS

Assembly Steps

STEP 1:

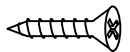
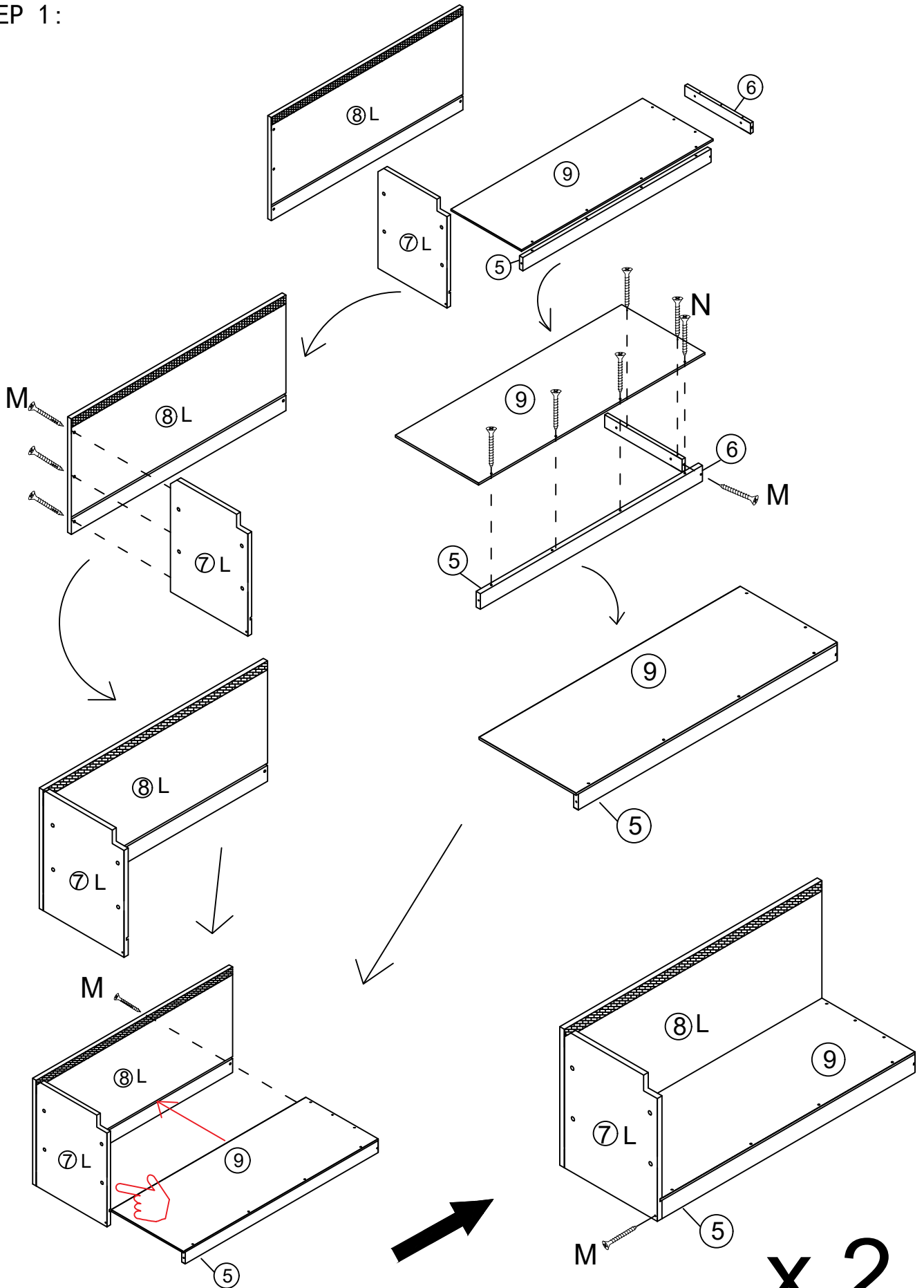

M x 12 PCS

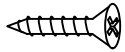

N x 12PCS

Assembly Steps

STEP 2:

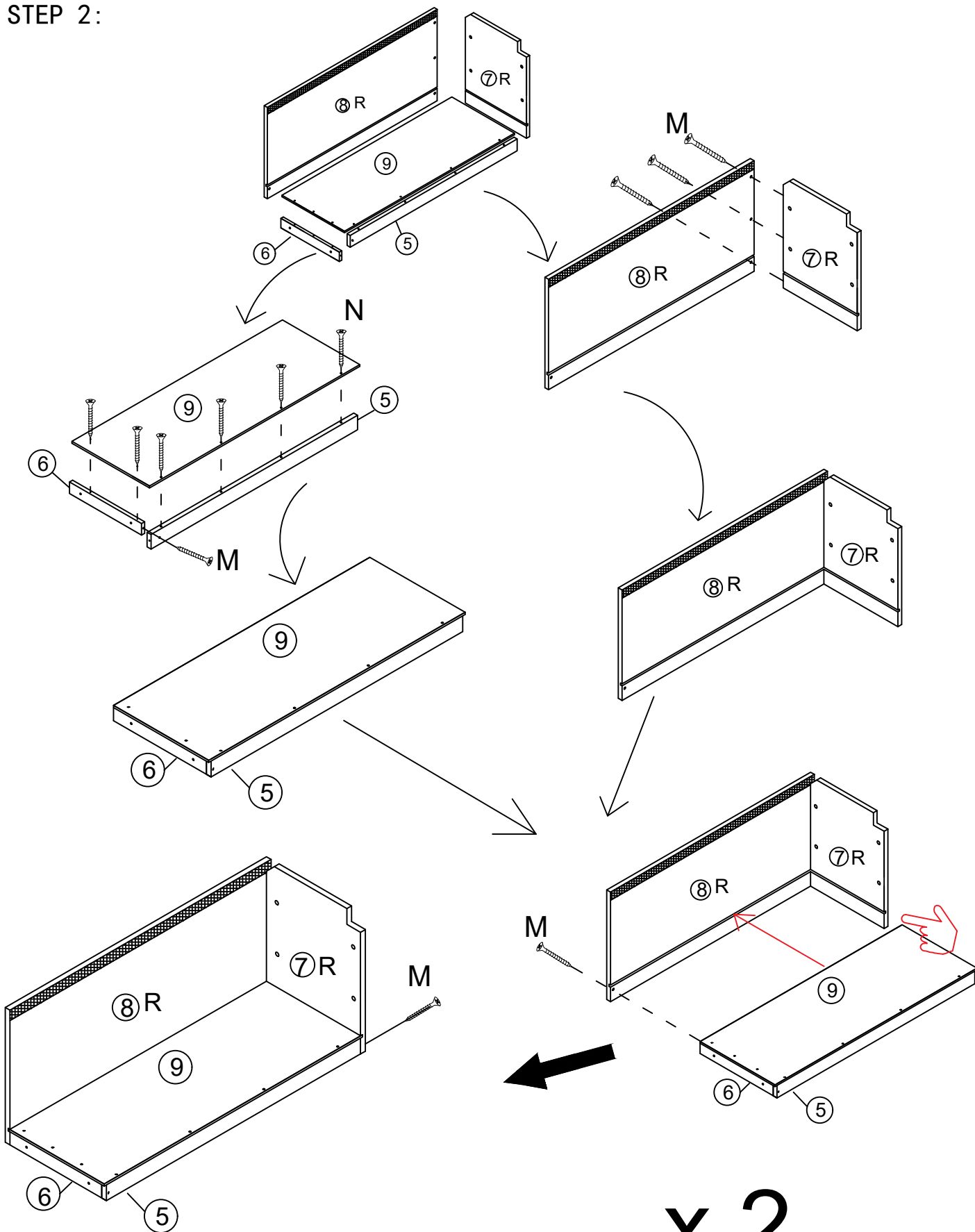

x 2

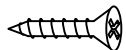

Mx12 PCS

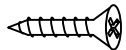

N x 12PCS

Assembly Steps

STEP 3:

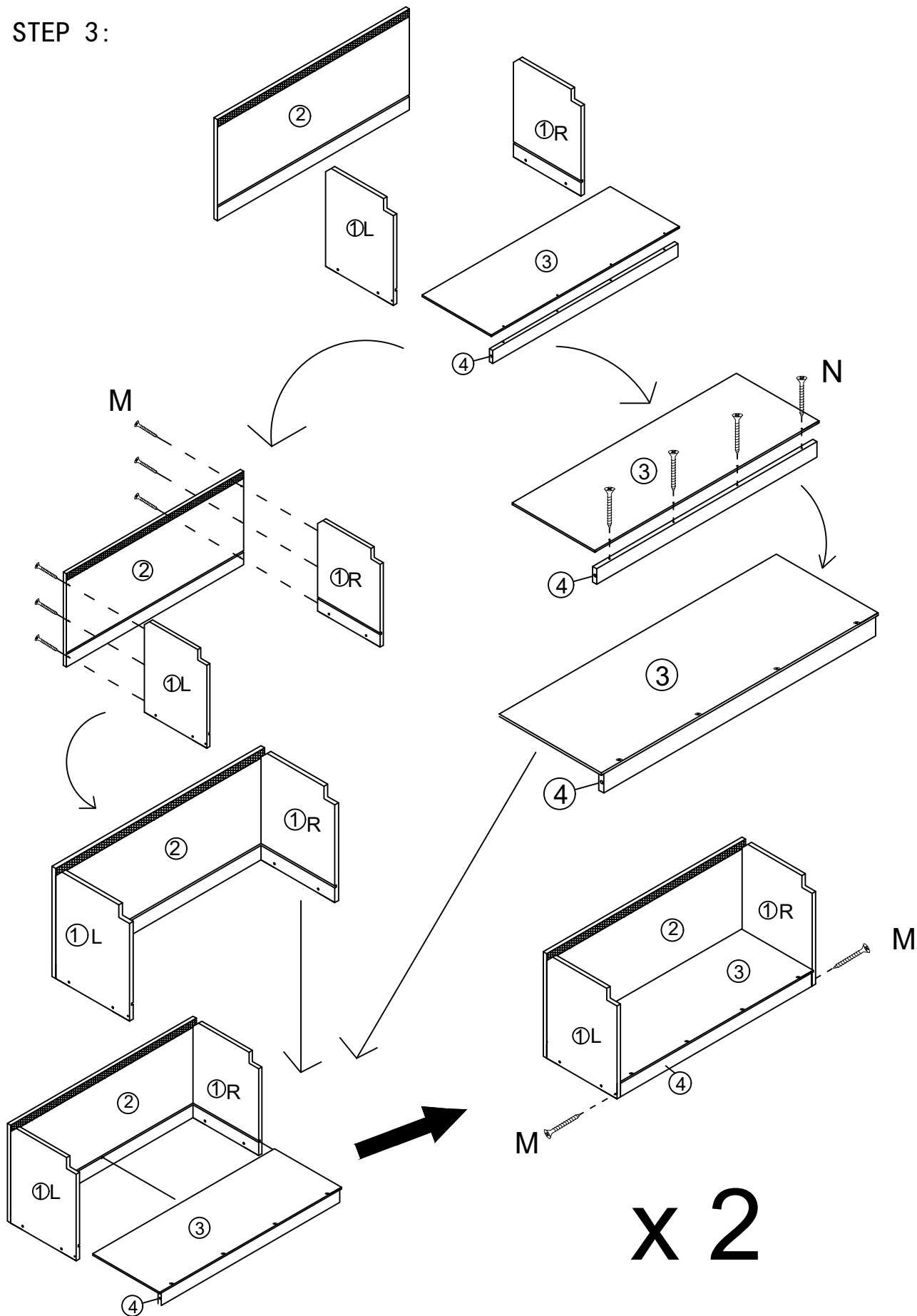



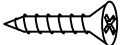
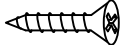



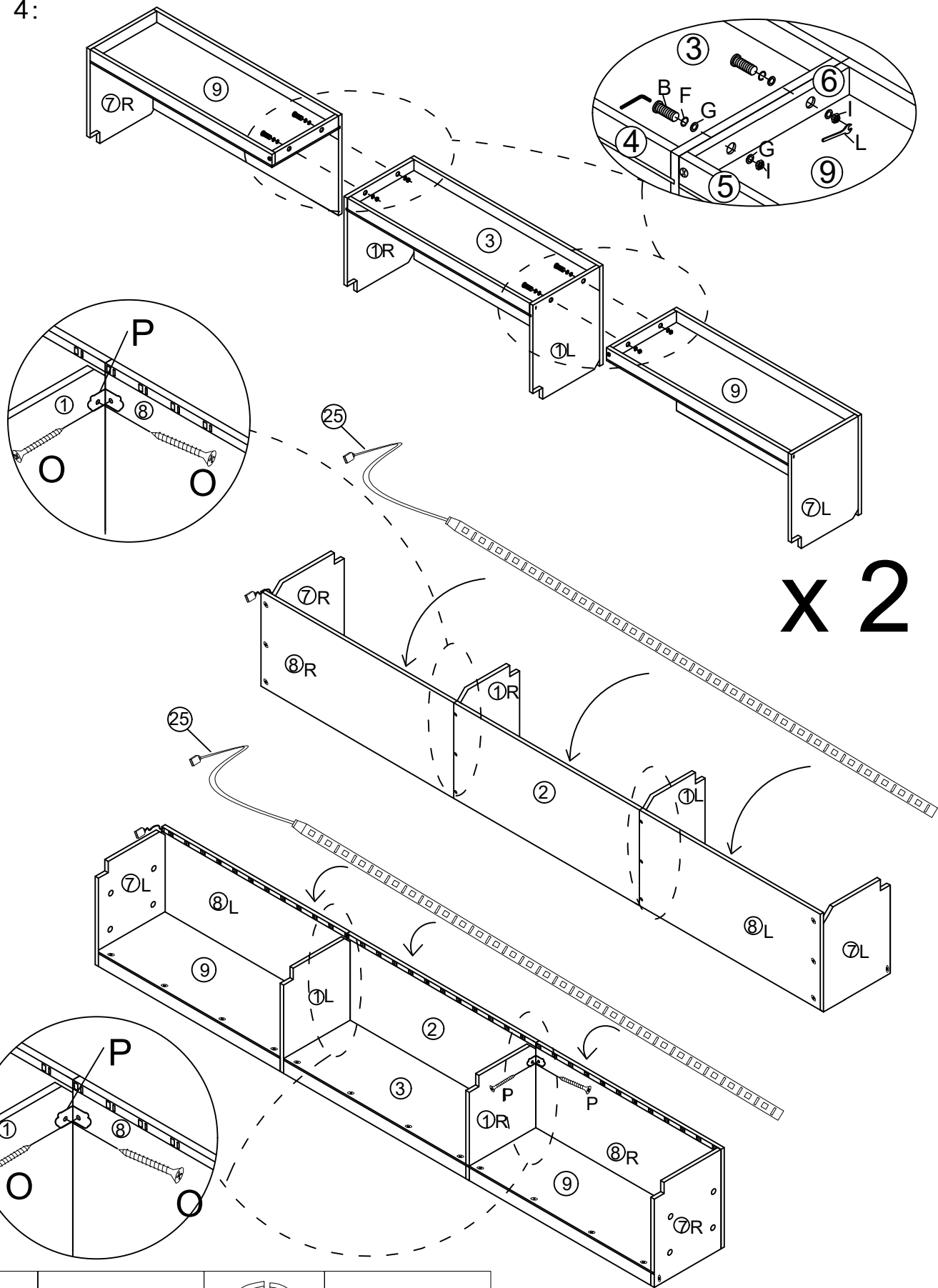

x 2

	M x16PCS		N x 8PCS
---	----------	---	----------

Assembly Steps

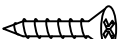
STEP 4:





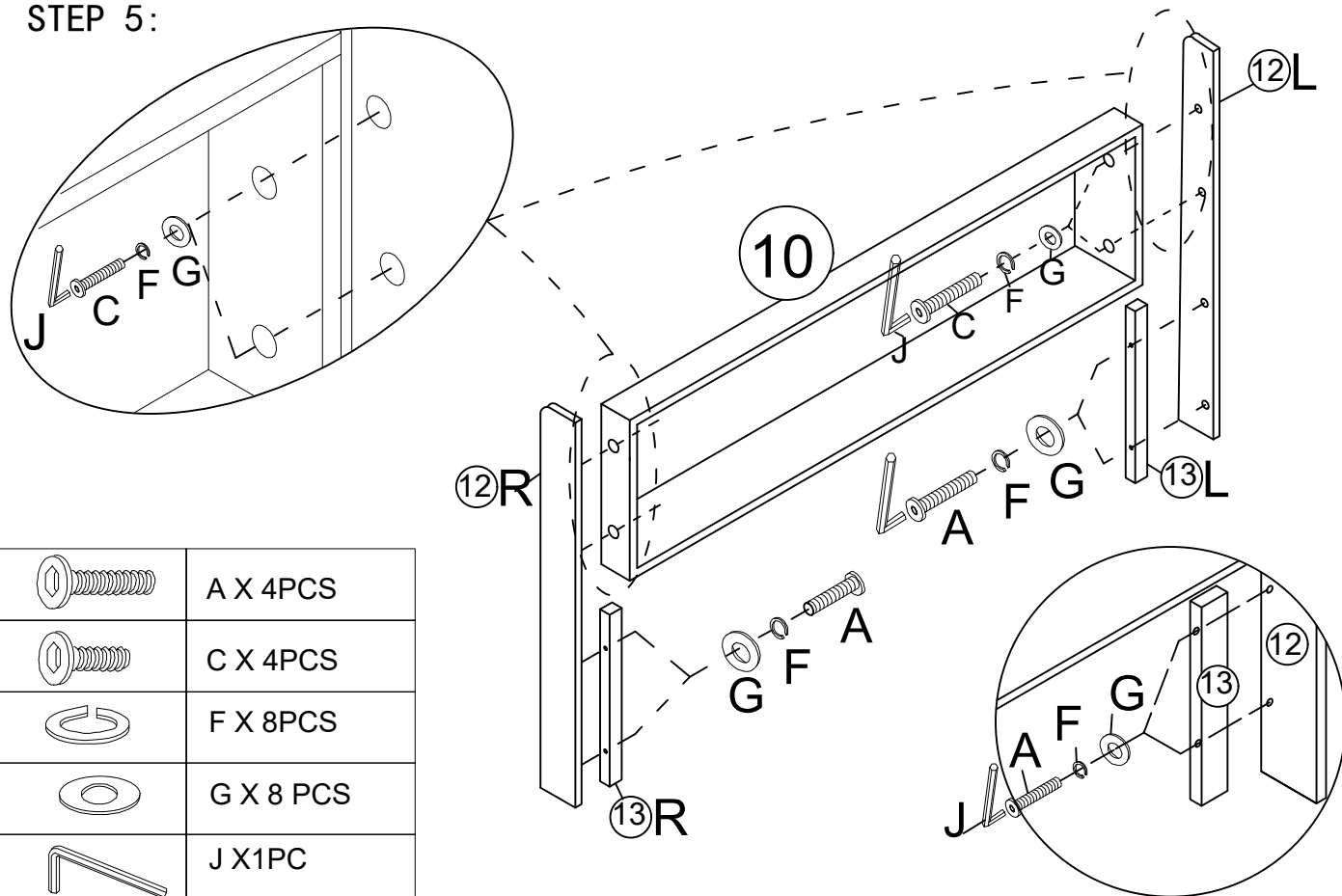

	P x 4PCS		F x 8PCS		I x 8PCS
	B x 8PCS		O x 8PCS		L x 1PC
	G x 16PCS		J x 1PC		

Assembly Steps

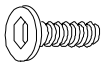

STEP 5:

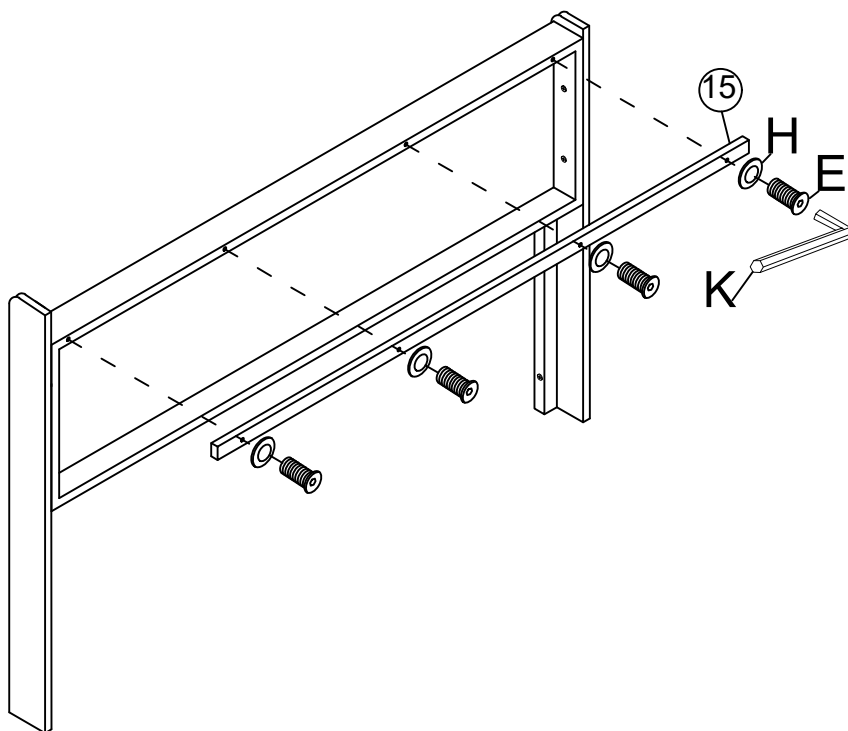

	A X 4PCS
	C X 4PCS
	F X 8PCS
	G X 8 PCS
	J X 1PC

STEP 6:

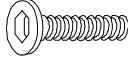



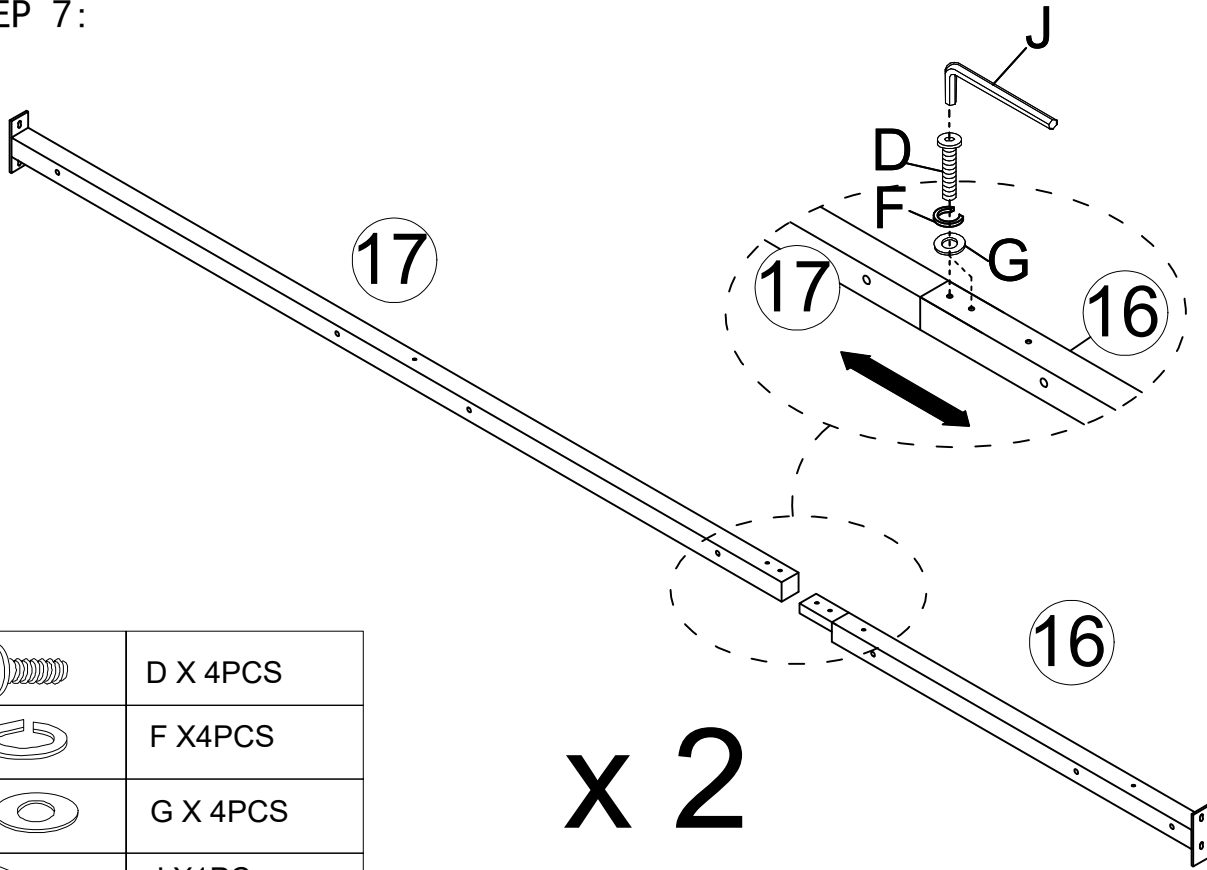

	E X 4PCS		H X 4 PCS		K X 1PC
---	----------	---	-----------	--	---------

Assembly Steps





STEP 7:

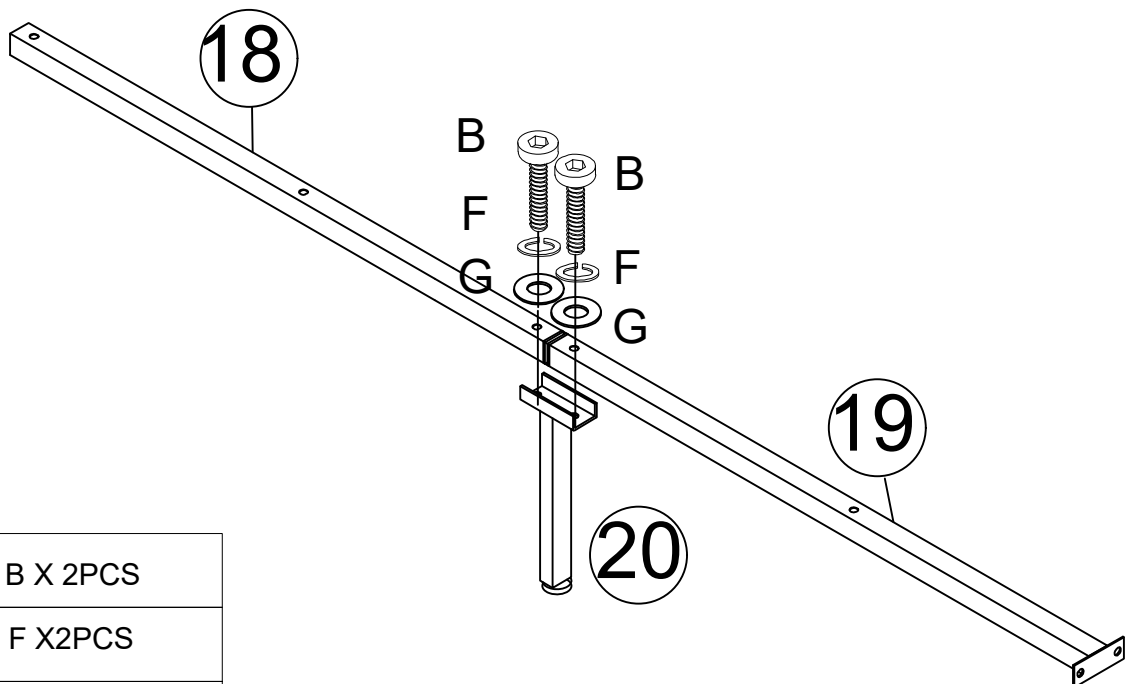

	D X 4PCS
	F X4PCS
	G X 4PCS
	J X1PC

STEP 8:





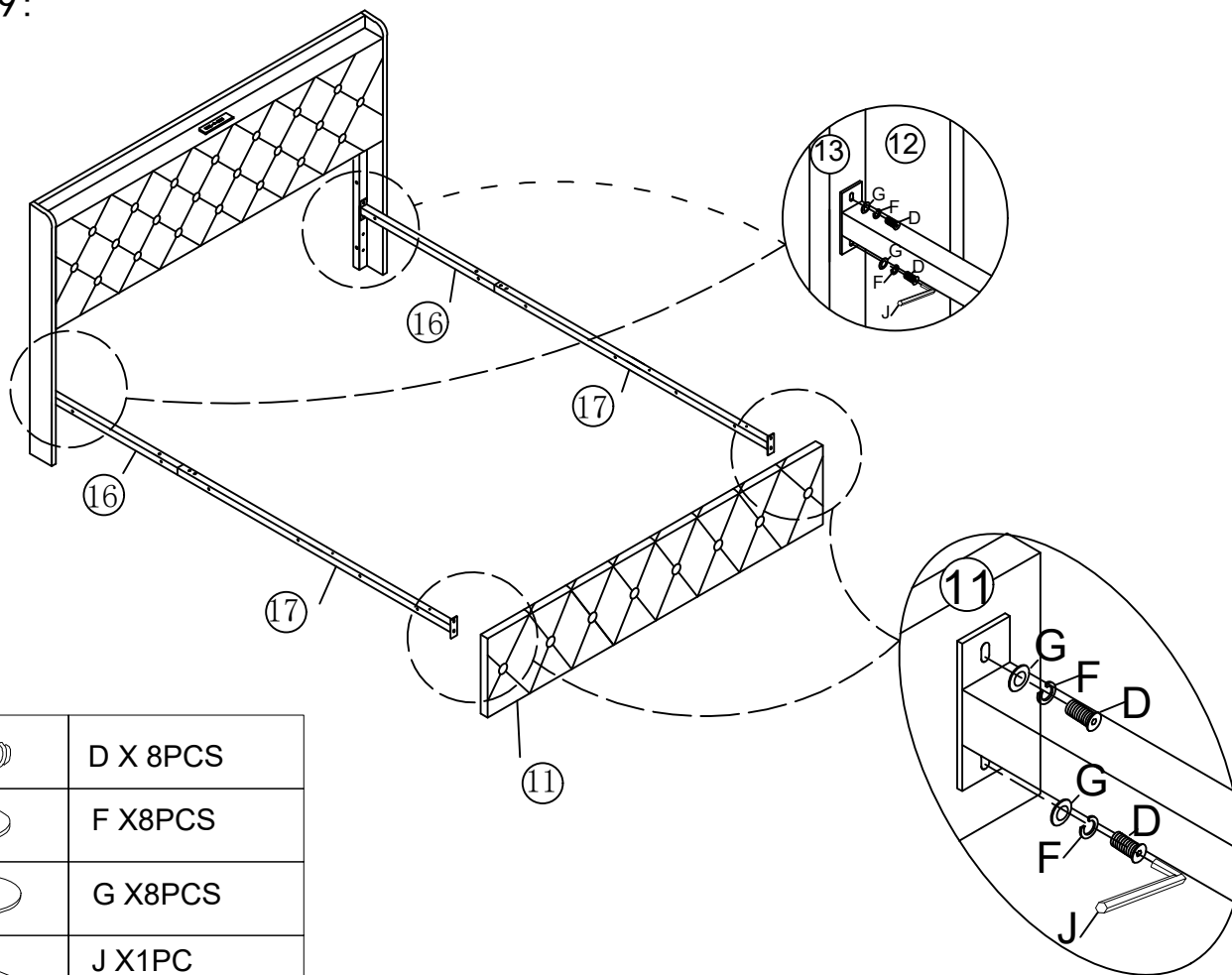

	B X 2PCS
	F X2PCS
	G X 2PCS
	J X1PC

Assembly Steps





STEP 9:

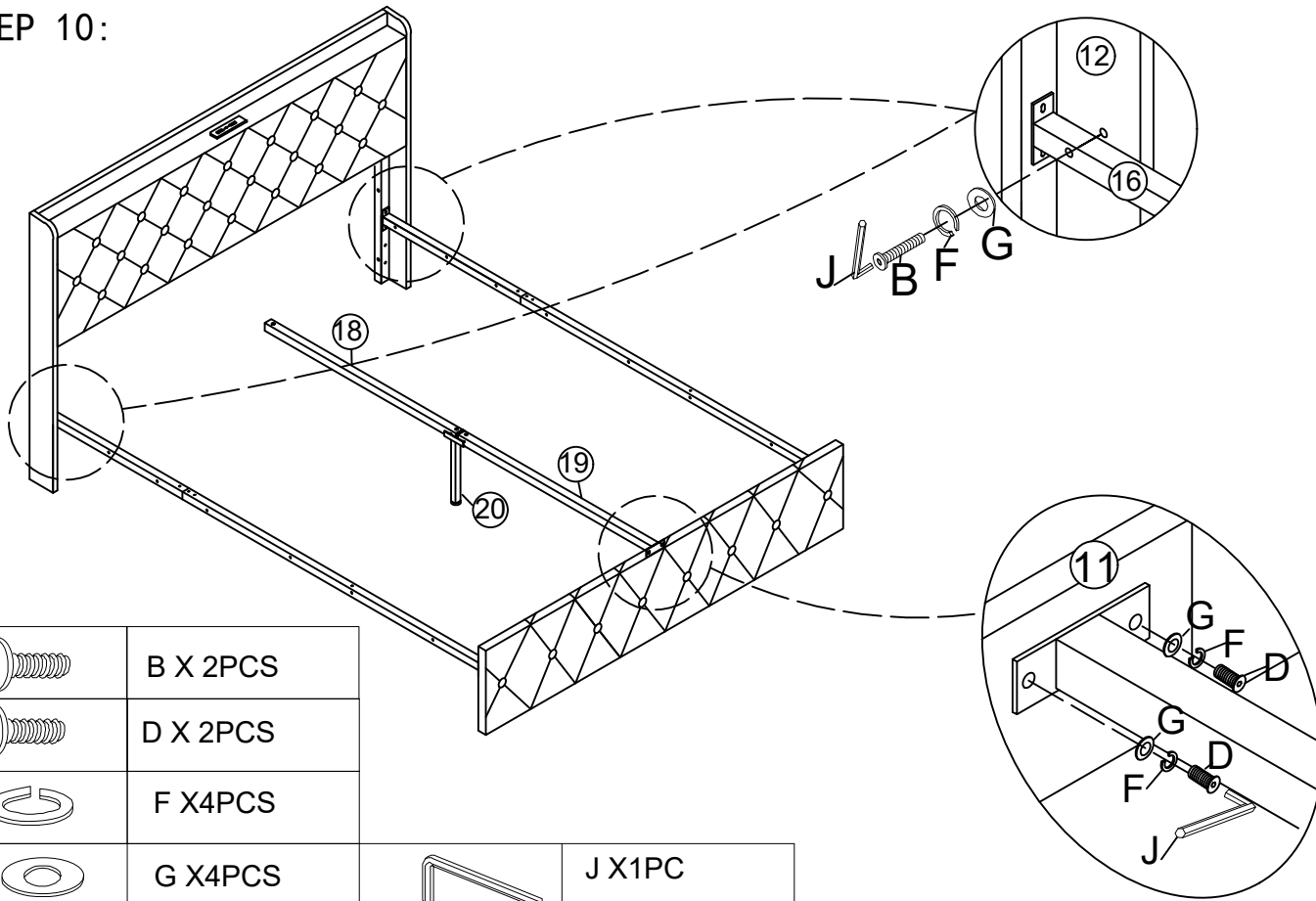

	D X 8PCS
	F X8PCS
	G X8PCS
	J X1PC

STEP 10:





	B X 2PCS		D X 2PCS
	F X4PCS		
	G X4PCS		J X1PC

Assembly Steps

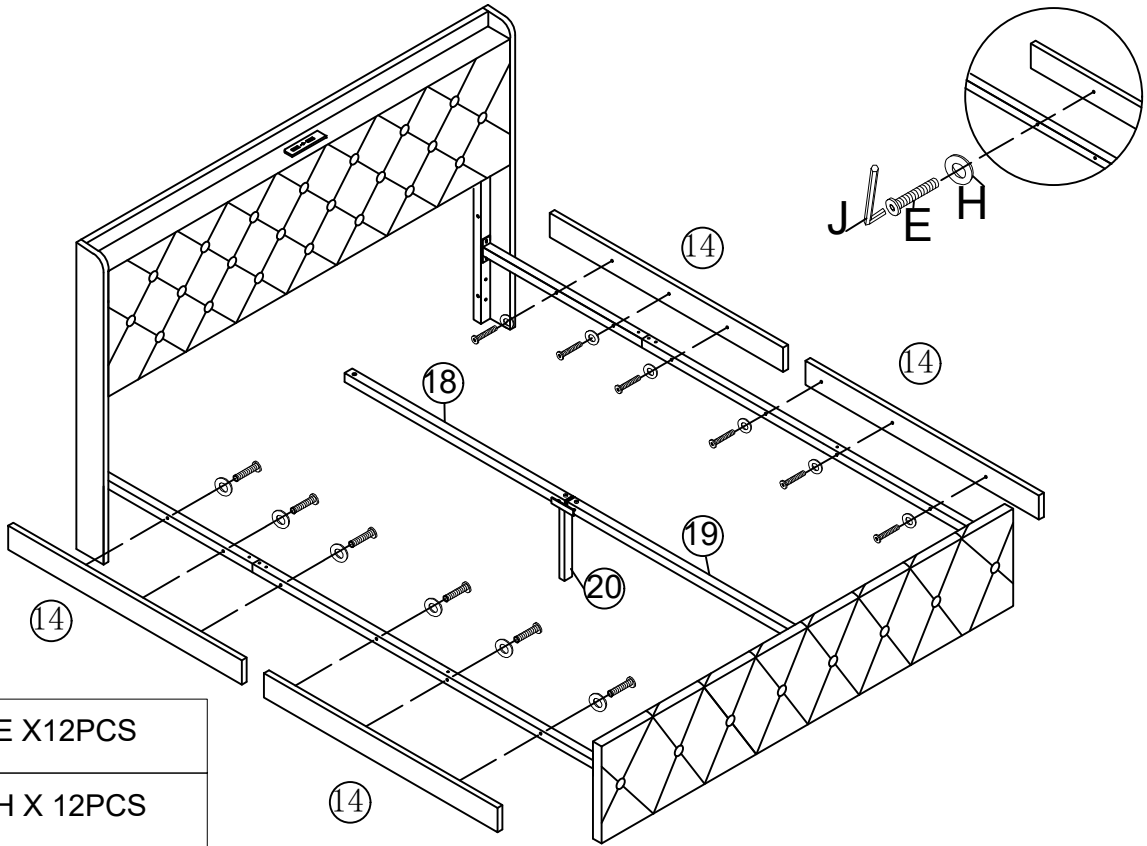
STEP 11:

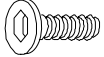

	E X12PCS
	H X 12PCS
	K X1PC



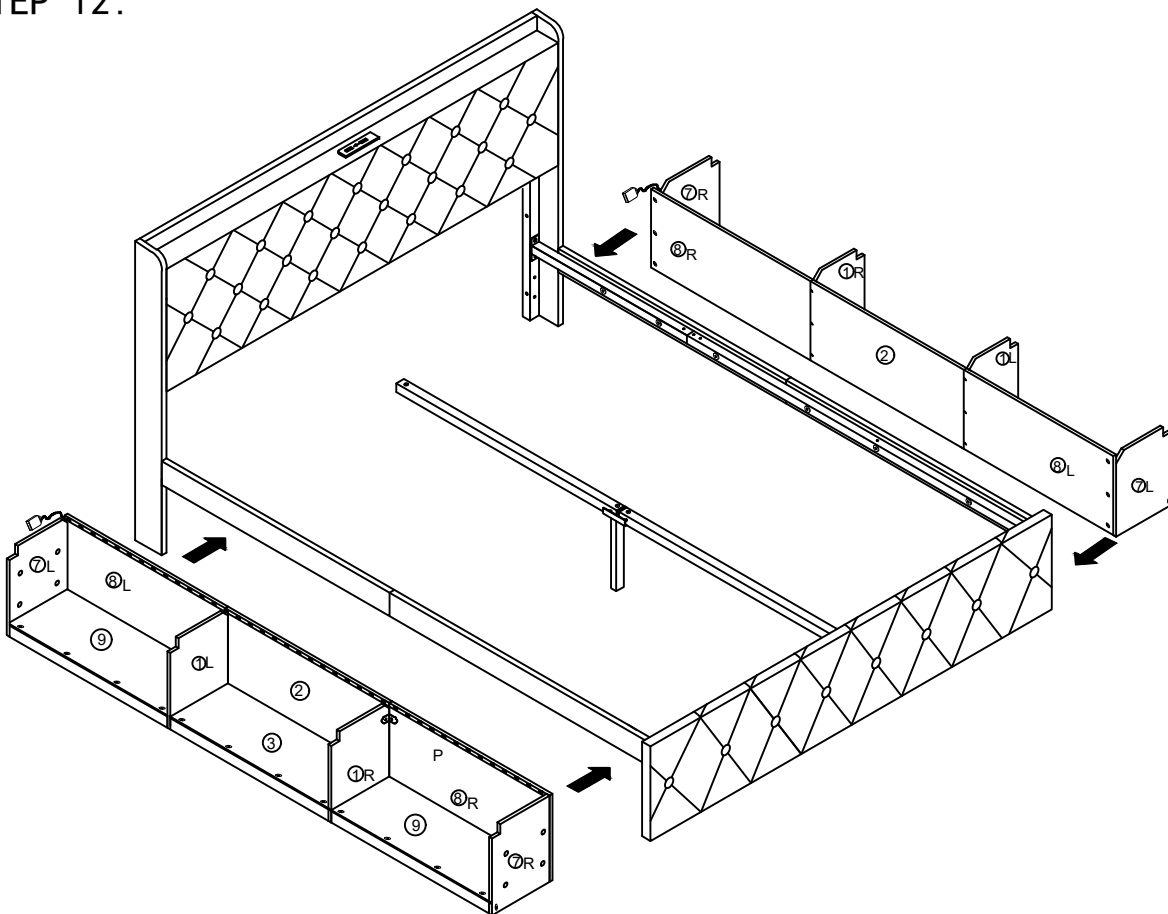

STEP 12:

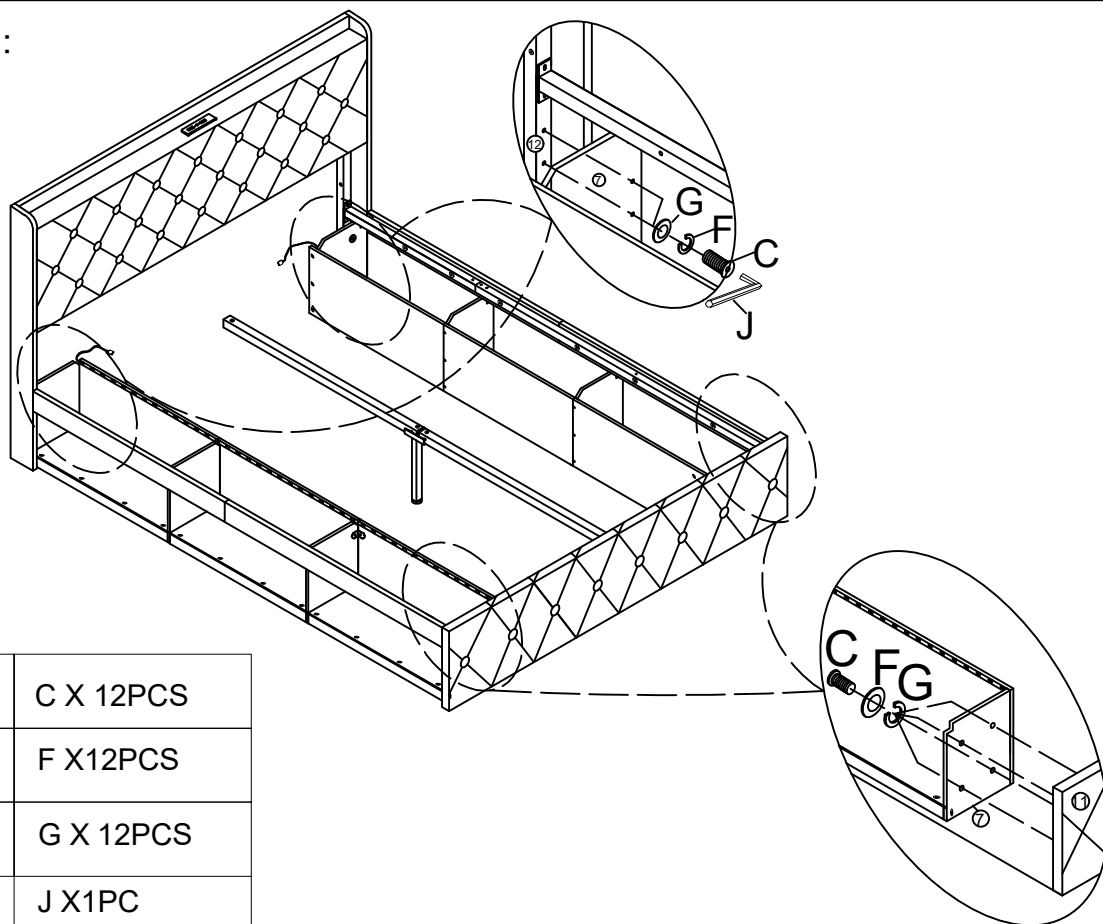

Assembly Steps



STEP 13:

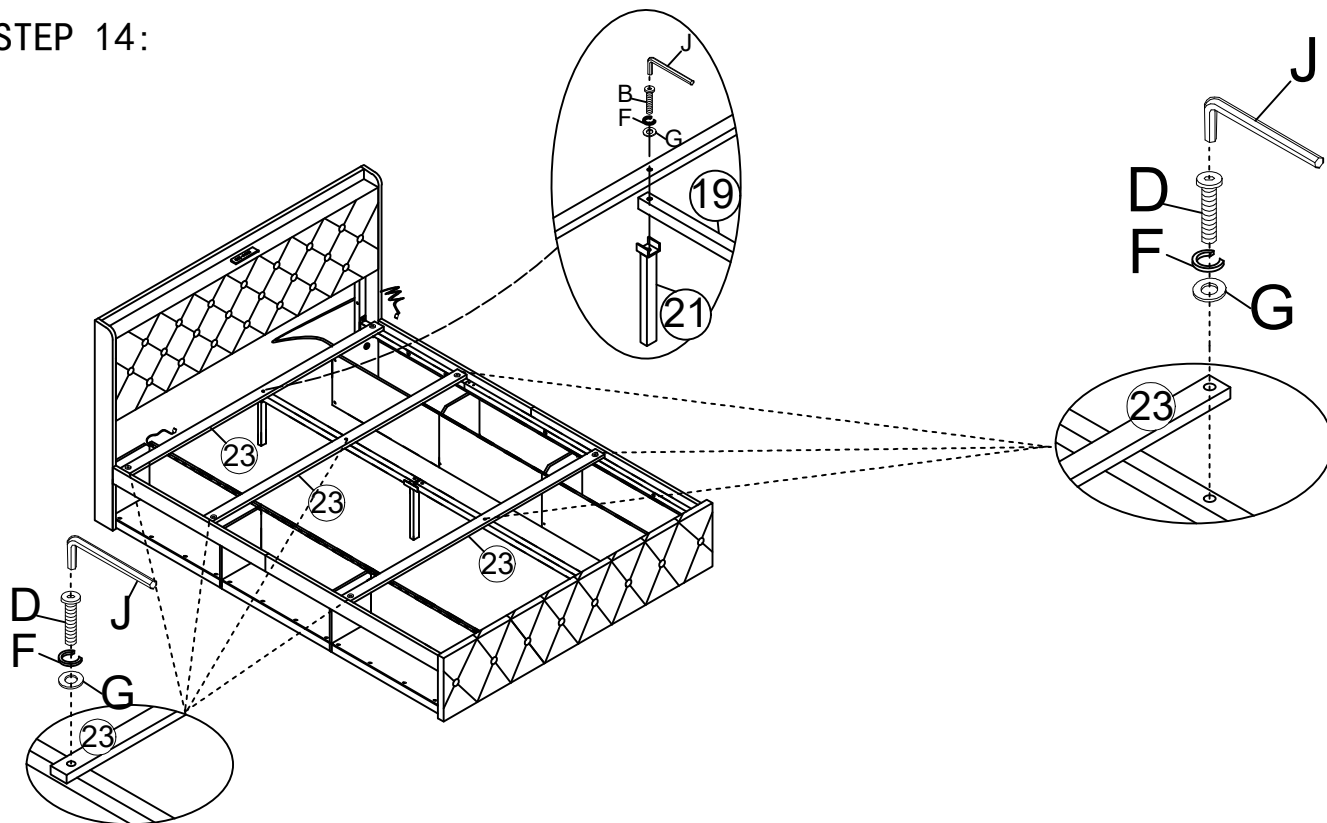

	C X 12PCS
	F X 12PCS
	G X 12PCS
	J X 1PC

STEP 14:



	B X 1PCS		F X 9PCS		
	D X 8PCS		G X 9PCS		J X 1PC

Assembly Steps

STEP 15:

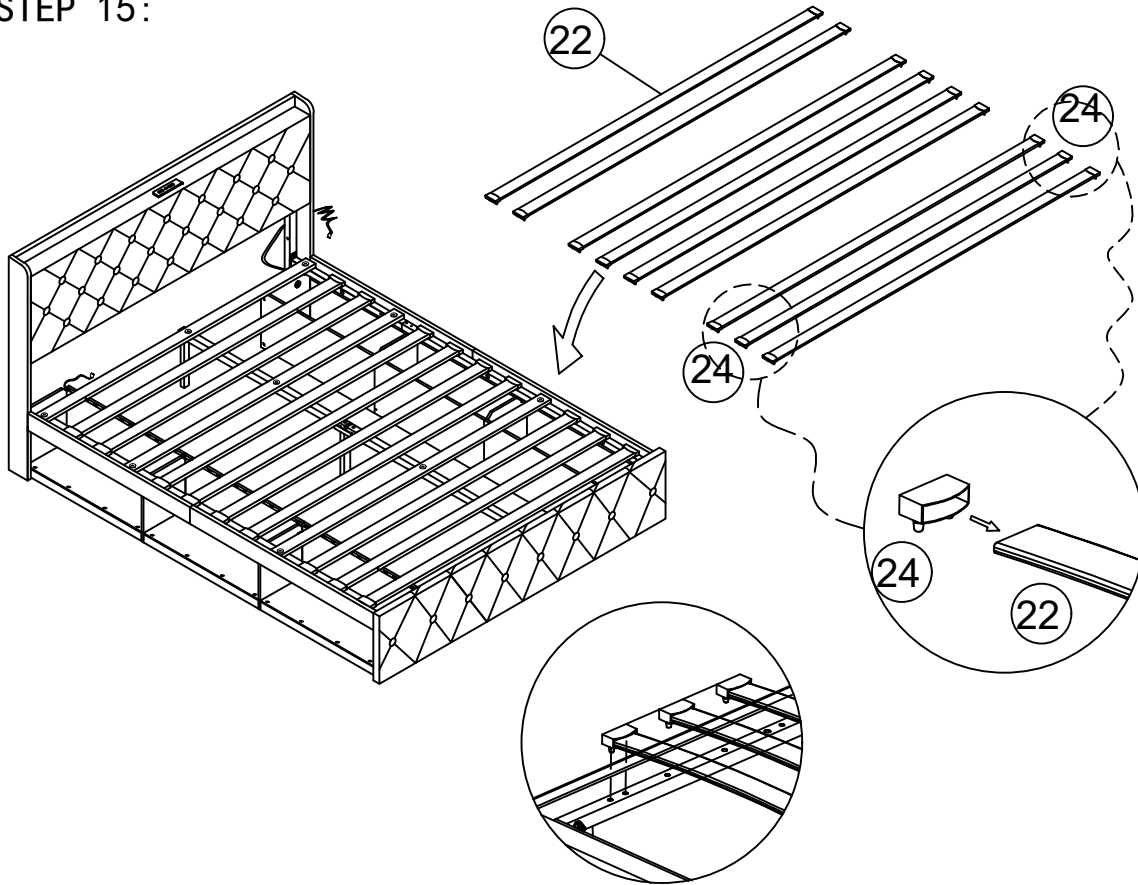

STEP 16:

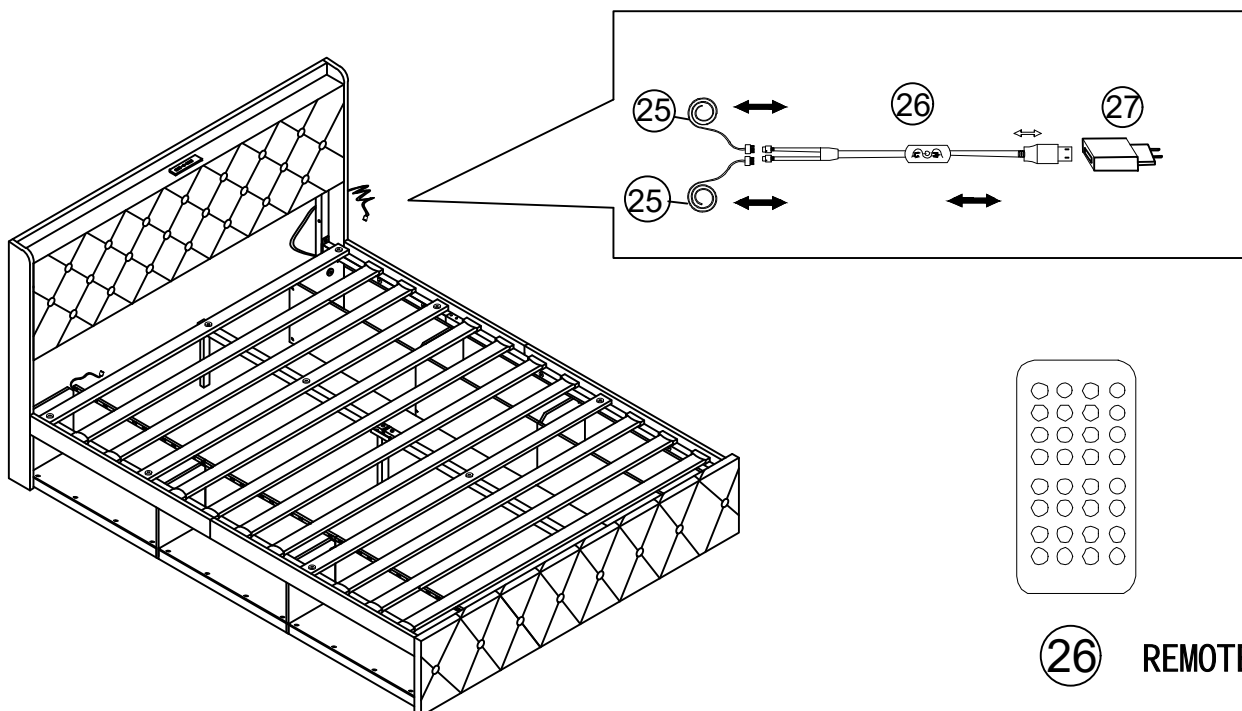

26 REMOTE CONTROL