

ASSEMBLY INSTRUCTION
ASSEMBLERBEFEHL
INSTRUCTIONS DE MONTAGE

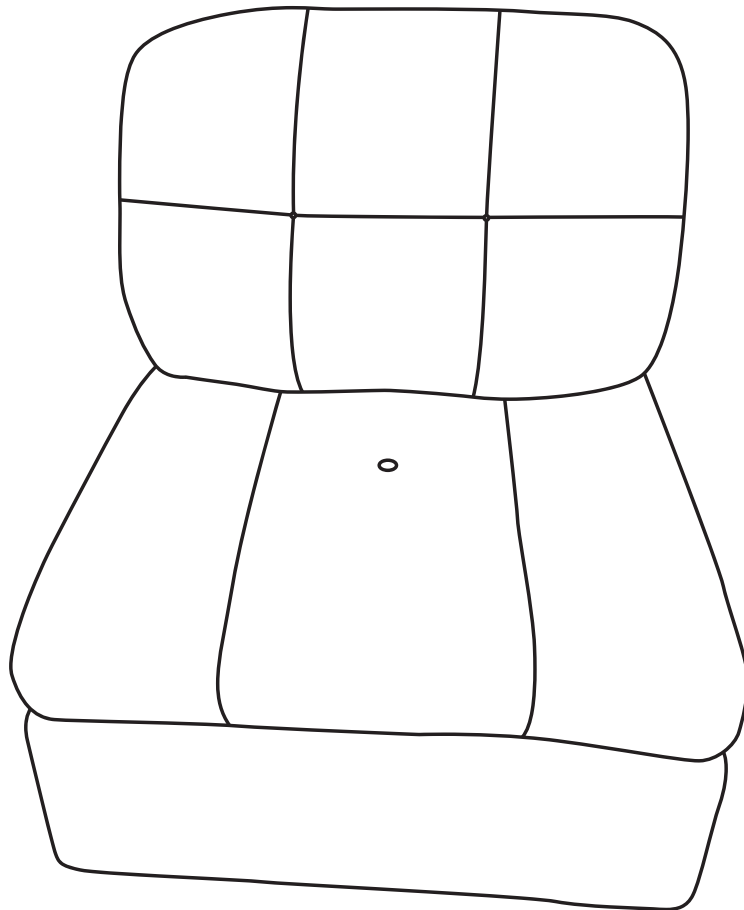

ITEM#N8873P89273



Importeur	Decobus Handel GmbH
Adresse	Innungsstraße 9,21244 Buchholz,Deutschland
URL	https://www.decobusgroup.de
Hersteller	SHUNCORE INTERNATIONAL LIMITED
Adresse	Room S239, 2/F, Capital Plaza, 61-65 Cotton Tree Road South, Tsim Sha Tsui, Hong Kong
Email/URL	15672759272@163.com
Partienummer	C258SCI20250922ZR
Hergestellt in	China
	Decobus Handel GmbH Innungsstraße 9,21244 Buchholz,Deutschland http://www.decobusgroup.de



[DE]

Warnung: Lesen Sie die Anleitung vor dem Zusammenbau bitte vollständig durch. Überprüfen Sie, ob Sie alle auf den Seiten aufgeführten Komponenten und Werkzeuge haben.

Warnung: Überprüfen Sie regelmäßig alle Beschläge und Befestigungen, um sicherzustellen, dass sie sicher sind und um Unfälle zu vermeiden.

Warnung: Stellen Sie Möbel nicht in die Nähe von Feuerquellen oder heißen Gegenständen, um Brandgefahr zu vermeiden.

Warnung: Erlauben Sie Kindern nicht, auf die Möbel zu klettern, da dies zum Umkippen und zu schweren Verletzungen führen kann. Bauen Sie die Möbel außerhalb der Reichweite von Kindern zusammen.

[EN]

Warning: Please read instructions fully before starting assembly. Check you have all the components and tools listed on pages.

Warning: Regularly check all fittings and fastenings to ensure they are secure and to prevent accidents.

Warning: Do not place furniture close to fire sources or high-temperature objects to avoid the risk of fire.

Warning: Do not allow children to climb on the furniture as this may result in tipping and serious personal injury. Assemble the furniture away from the reach of children.

[FR]

Avertissement : Veuillez lire entièrement les instructions avant de commencer l'assemblage. Vérifiez que vous disposez de tous les composants et outils répertoriés sur les pages.

Avertissement : Vérifiez régulièrement tous les accessoires et fixations pour vous assurer qu'ils sont bien fixés et pour éviter les accidents.

Avertissement : Ne placez pas les meubles à proximité de sources de feu ou d'objets à haute température pour éviter tout risque d'incendie.

Avertissement : Ne laissez pas les enfants grimper sur les meubles car cela pourrait entraîner un basculement et des blessures graves. Assemblez les meubles hors de portée des enfants.

[IT]

Attenzione: leggere attentamente le istruzioni prima di iniziare il montaggio. Verificare di avere tutti i componenti e gli utensili elencati nelle pagine.

Attenzione: controllare regolarmente tutti i raccordi e gli elementi di fissaggio per assicurarsi che siano sicuri e prevenire incidenti.

Attenzione: non posizionare i mobili vicino a fonti di fuoco o oggetti ad alta temperatura per evitare il rischio di incendio.

Attenzione: non consentire ai bambini di arrampicarsi sui mobili poiché ciò potrebbe causare ribaltamenti e gravi lesioni personali. Montare i mobili lontano dalla portata dei bambini.

[ES]

Advertencia: Lea las instrucciones completamente antes de comenzar el montaje. Compruebe que tiene todos los componentes y herramientas que se enumeran en las páginas.

Advertencia: Compruebe periódicamente todos los accesorios y sujeciones para asegurarse de que estén seguros y evitar accidentes.









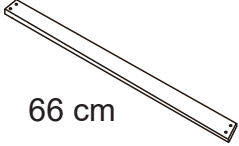
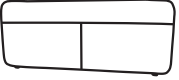

Advertencia: No coloque los muebles cerca de fuentes de fuego u objetos a alta temperatura para evitar el riesgo de incendio.

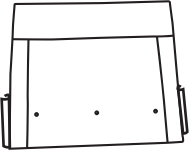
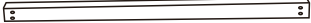
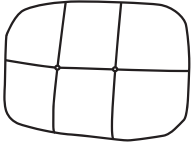
Advertencia: No permita que los niños se suban a los muebles, ya que esto puede provocar que vuelquen y lesiones personales graves. Monte los muebles fuera del alcance de los niños.

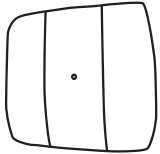
STÜCKLISTEN KASTEN 1:N8873P89273

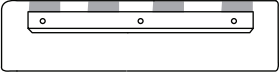
PART LISTS BOX 1:N8873P89273

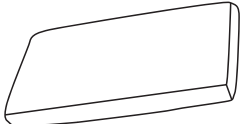
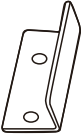
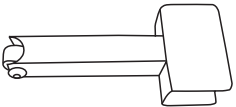
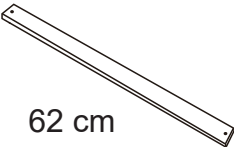

LISTES DE PIÈCES CASE 1:N8873P89273

Teile-Nr. Part NO. N° de pièce	TeileImage Part Image Partie Image	QTY QTY QTÉ	Teile-Nr. Part NO. N° de pièce	TeileImage Part Image Partie Image	QTY QTY QTÉ
1		1	11	 66 cm	4
2		1	12		1
3		1	13		1
4		1	14		1
5		1	15		1
6		1	16		1
7		1	17		2
8		1	18		2
9		2			
10	 62 cm	9			

STÜCKLISTEN KASTEN 1:N8873P89273

PART LISTS BOX 1:N8873P89273

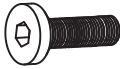
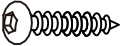
LISTES DE PIÈCES CASE 1:N8873P89273

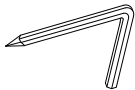
Teile-Nr. Part NO. N° de pièce	TeileImage Part Image Partie Image	QTY QTY QTÉ	Teile-Nr. Part NO. N° de pièce	TeileImage Part Image Partie Image	QTY QTY QTÉ
A	 M6x20mm	8			
B	 M6x30mm	12			
C	 M4x25mm	28			
D	 M6x40mm	3			
E		1			

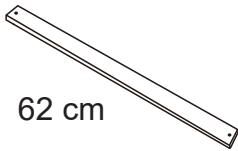
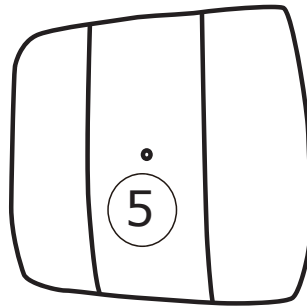
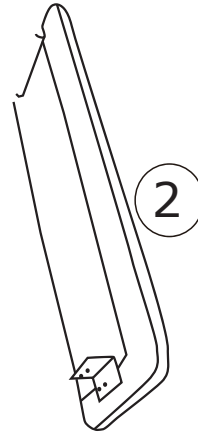
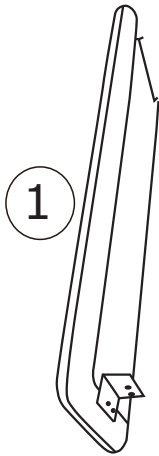
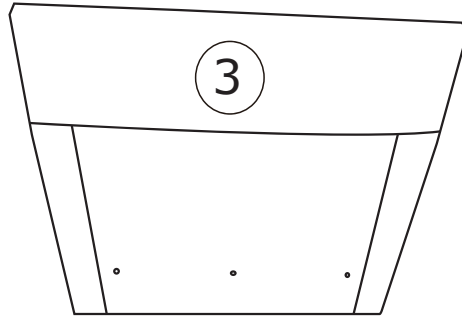
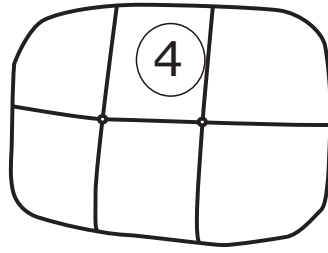

62 cm

10 X9

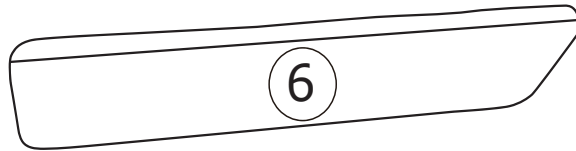

6

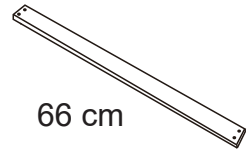

66 cm

11 X4

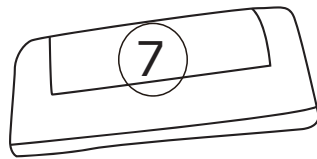

7

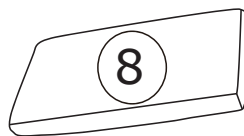

8

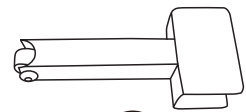

9

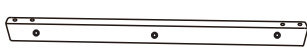

12



13



14



15



16

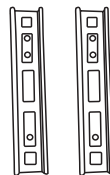

17

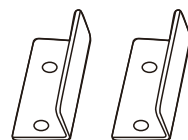

18

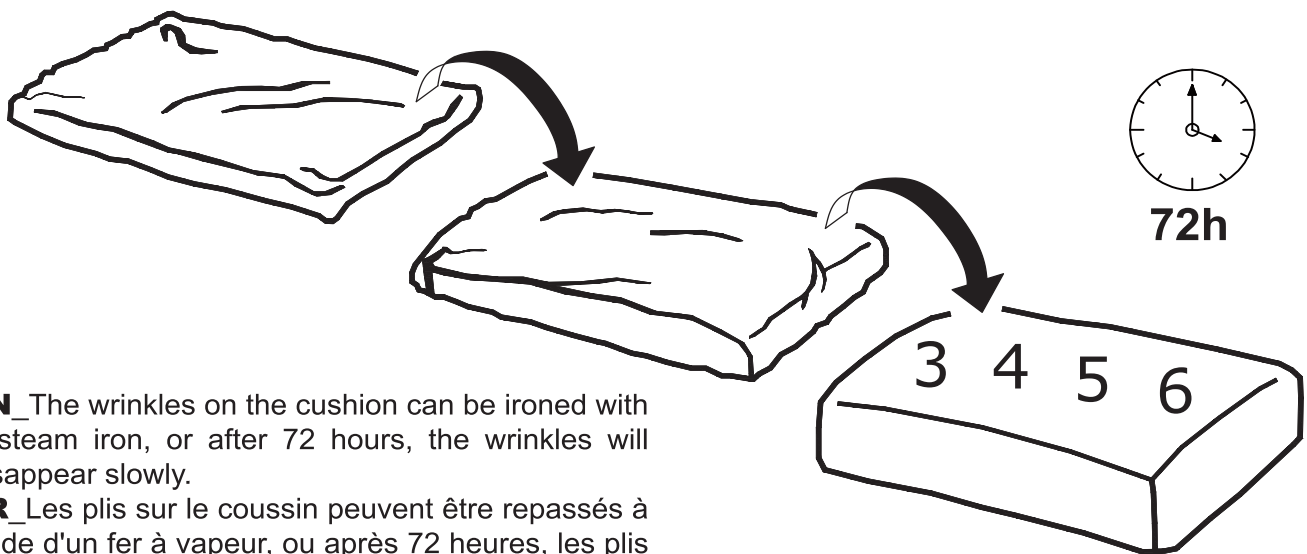
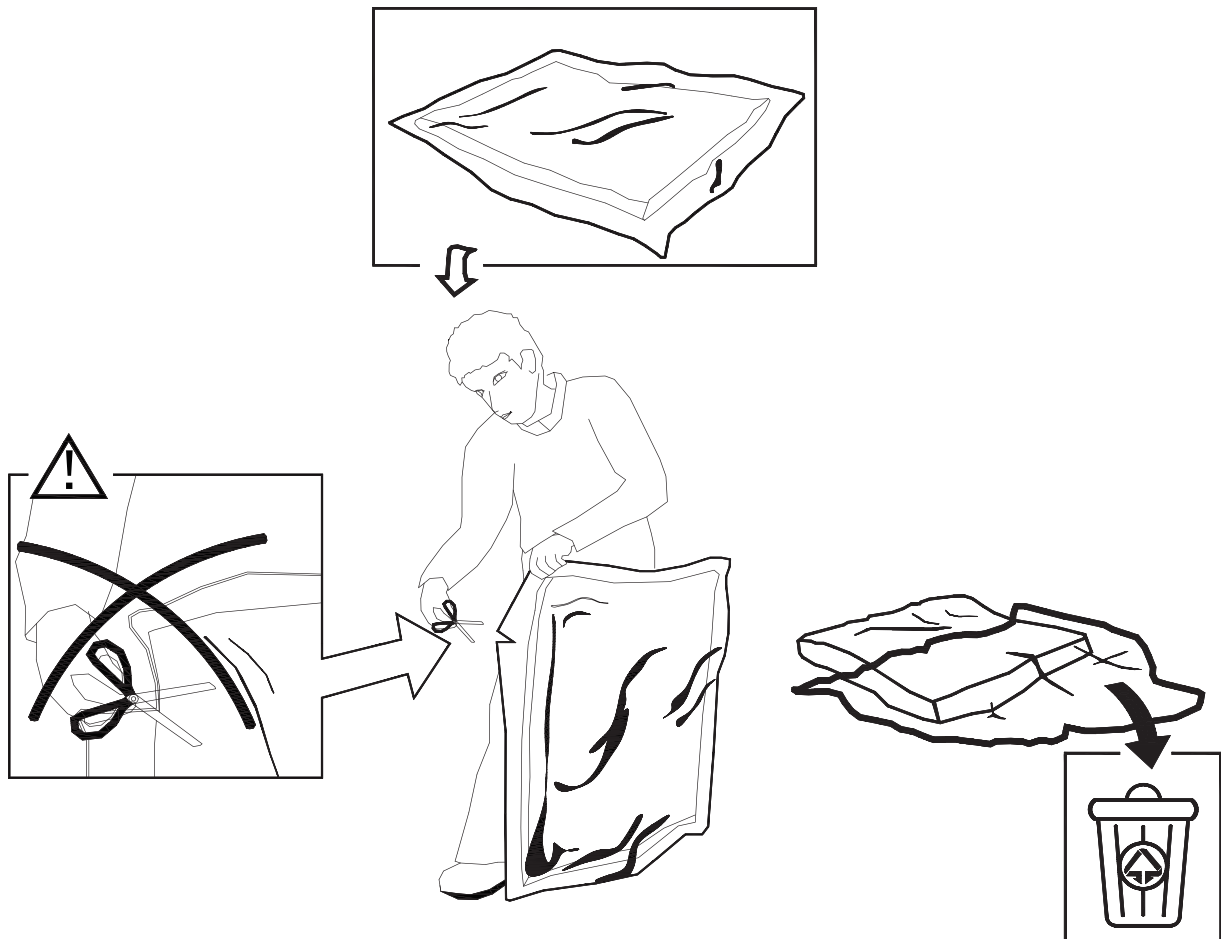

EN The wrinkles on the cushion can be ironed with a steam iron, or after 72 hours, the wrinkles will disappear slowly.

FR Les plis sur le coussin peuvent être repassés à l'aide d'un fer à vapeur, ou après 72 heures, les plis disparaîtront lentement.

DE Die Falten auf dem Kissen können mit einem Dampfbügeleisen gebügelt werden, oder nach 72 Stunden, werden die Falten langsam verschwinden.

ES Las arrugas del cojín se pueden planchar con una plancha de vapor, o desaparecerán lentamente después de 72 horas.

PT Pode-se passar as almofadas para remover o amassado usando ferro a vapor ou, após 72 horas, o amassado desaparece lentamente.

IT Le pieghe sul cuscino possono essere stirate con un ferro da stiro a vapore, oppure dopo 72 ore le pieghe scompariranno lentamente.

EN Make the backrest pillows fuller by tapping and squeezing them.

FR Rendez les coussins du dossier davantage pleins en les tapotant et en les pressant.

DE Die Kissen der Rückenlehne werden durch Klopfen und Zusammendrücken fülliger.

ES Hágalos más llenos golpeando y apretando los cojines del respaldo.

PT Bata e aperte as almofadas do encosto para deixá-las mais cheias.

IT Rendere i cuscini del supporto schienale più pieni battendoli e stringendoli.

1

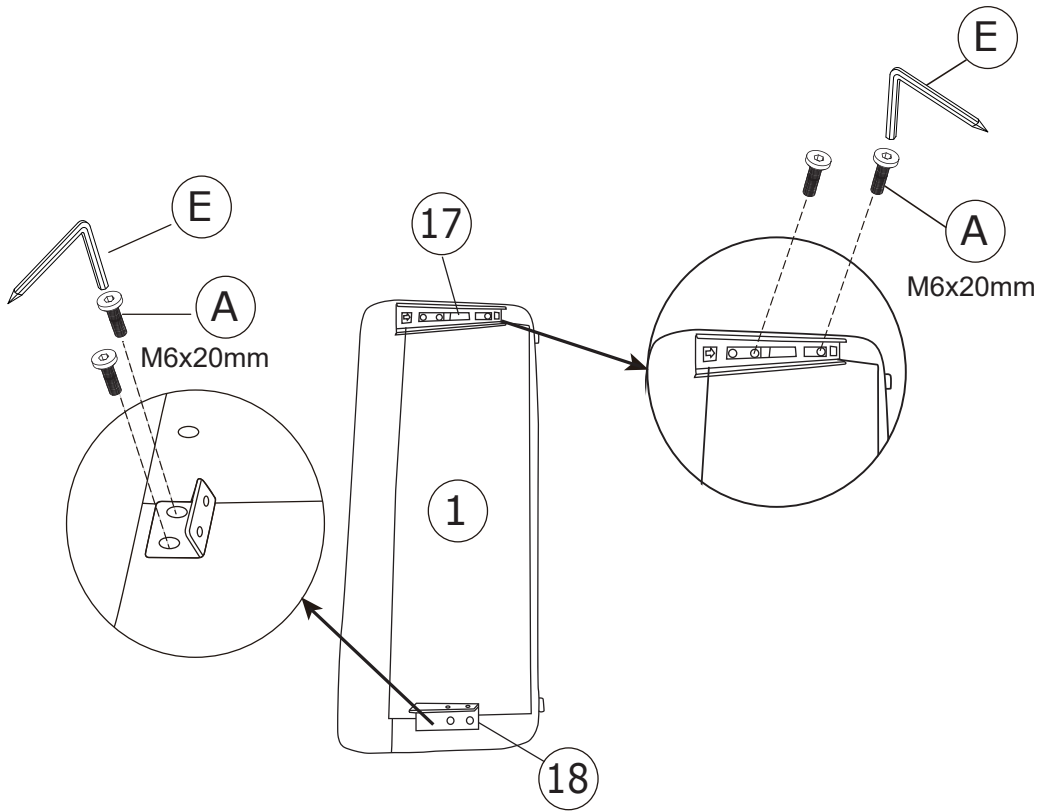

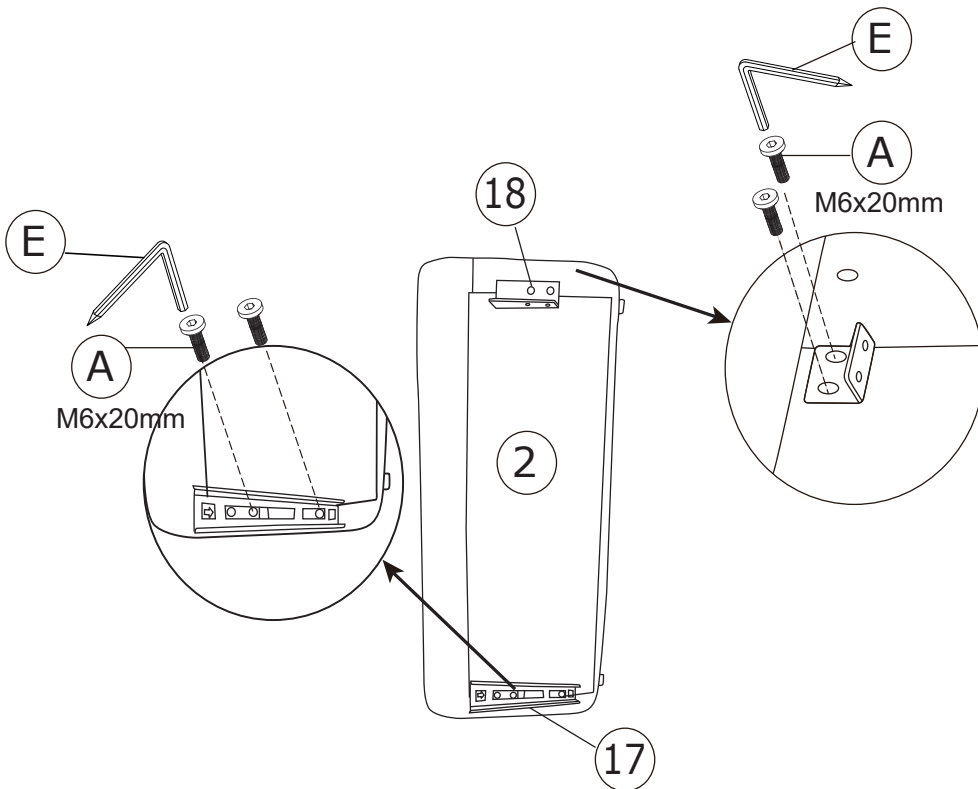

①		x1
①7		x1
①8		x1
Ⓐ	 M6x20mm	x4
Ⓔ		x1

2



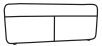
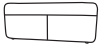

②		x1
①7		x1
①8		x1
Ⓐ	 M6x20mm	x4
Ⓔ		x1

3

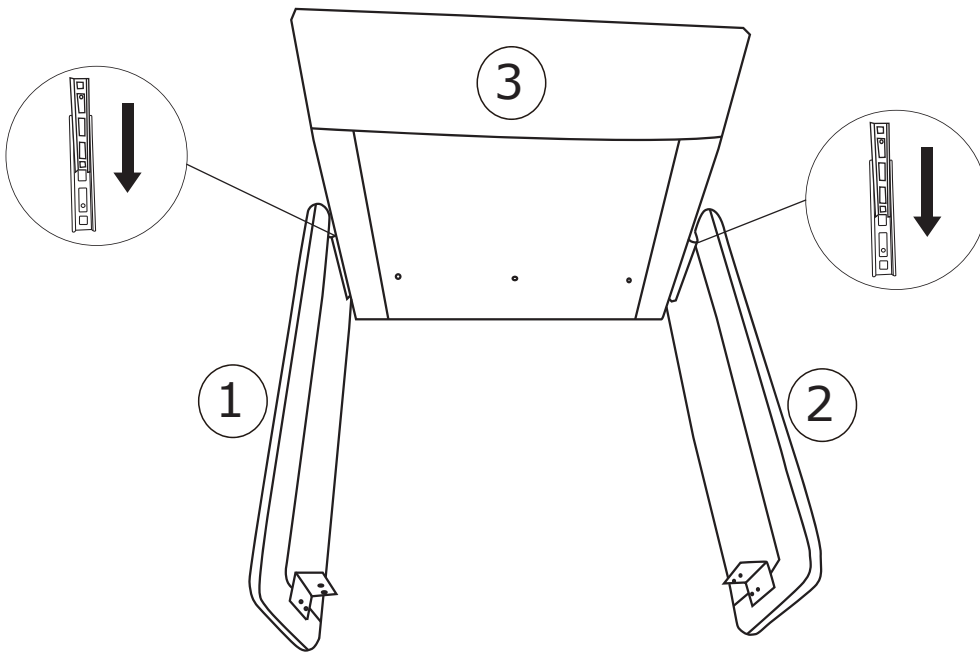
①		x1
②		x1
③		x1



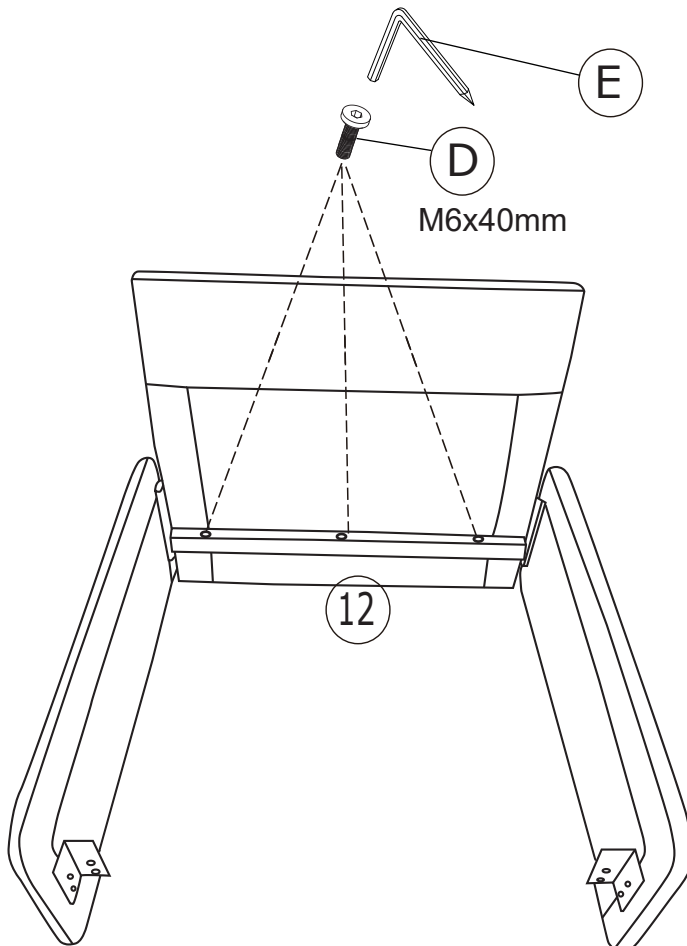

4

⑫		x1
D	 M6x40mm	x3
E		x1



5

13		x1
B	 M6x30mm	x4
E		x1

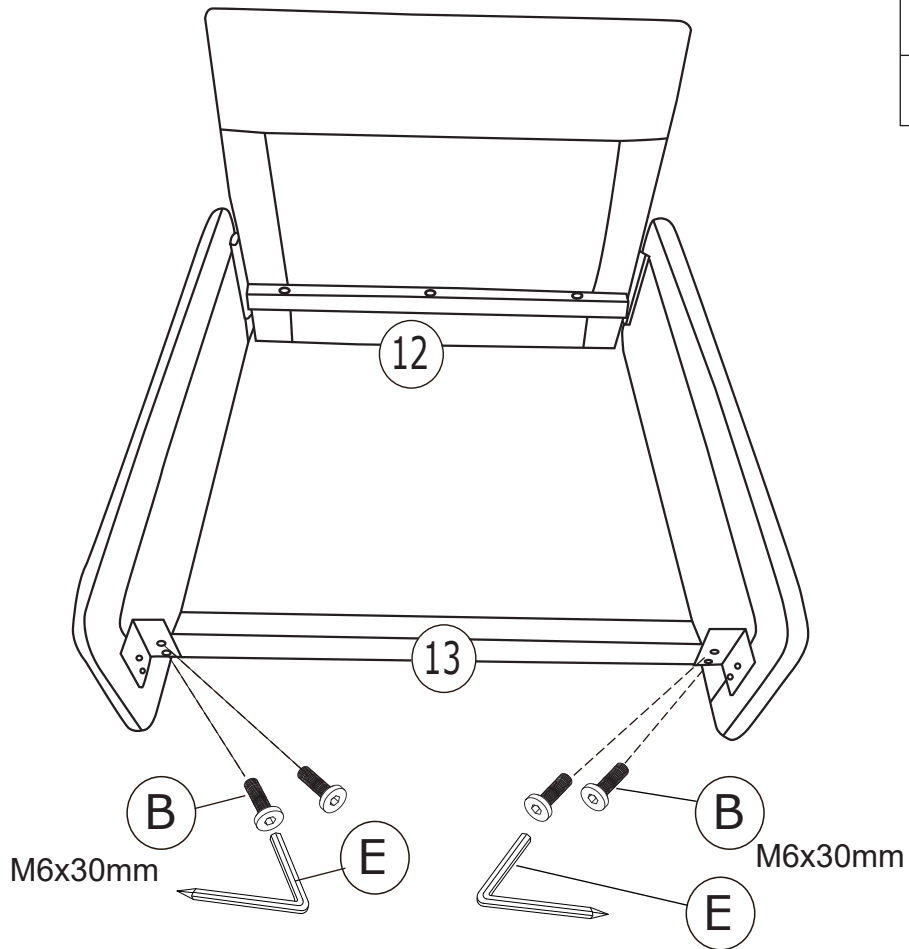



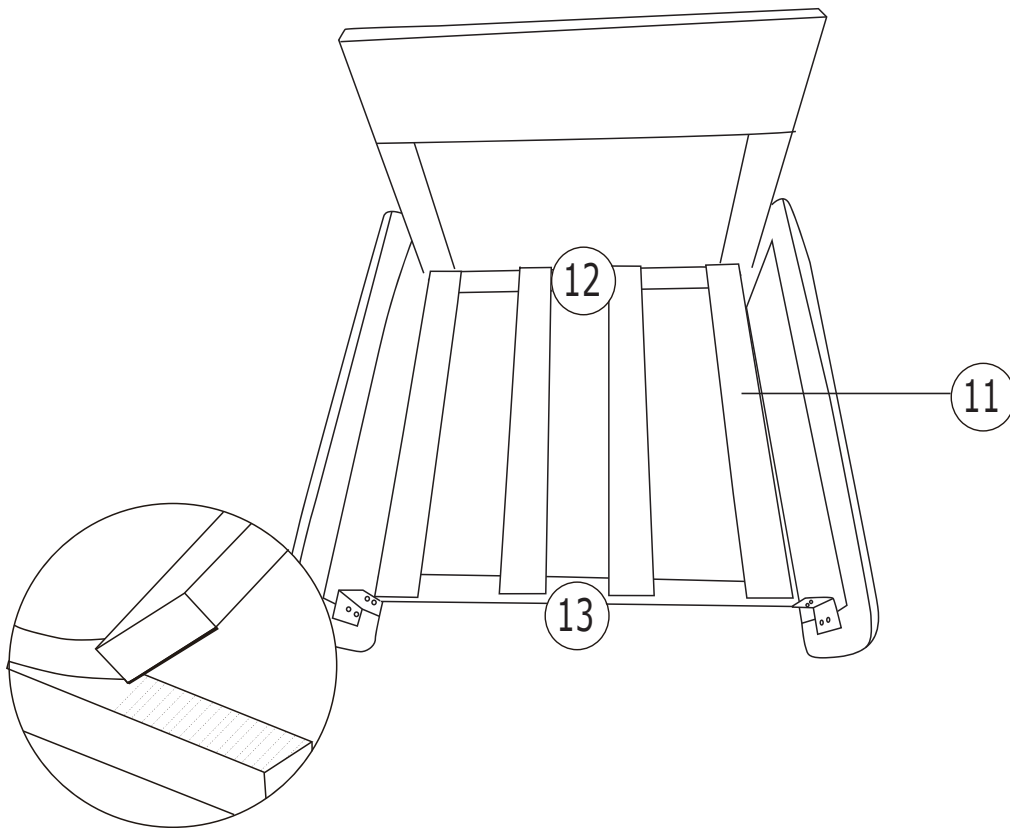

6

11	 66cm	x4
----	---	----

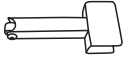



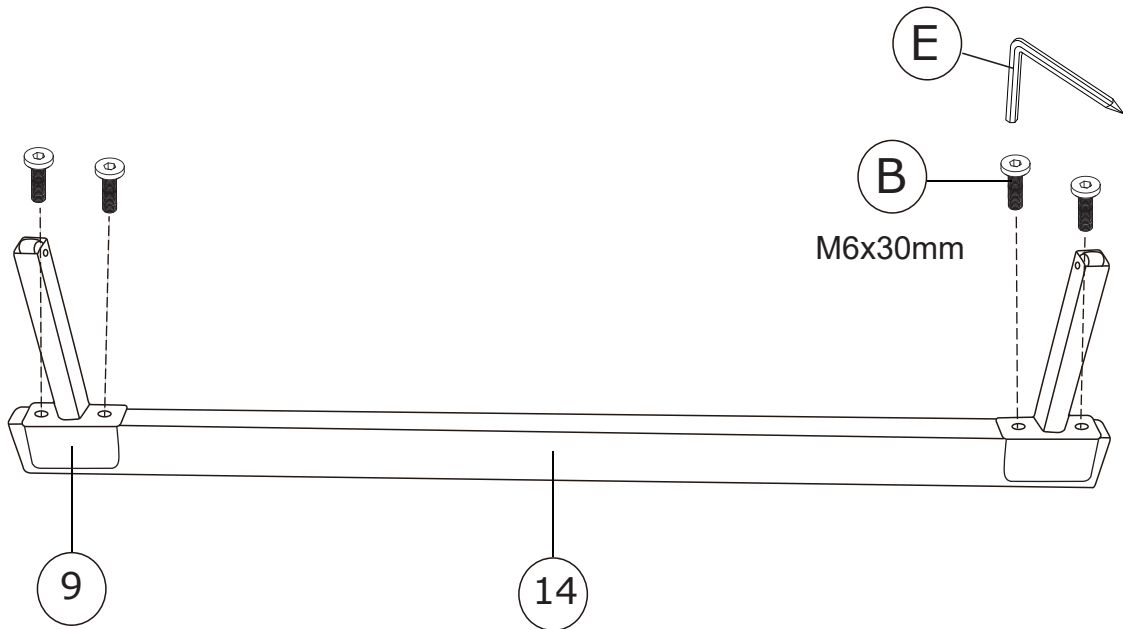

7

9		x2
14		x1
B	 M6x30mm	x4
E		x1



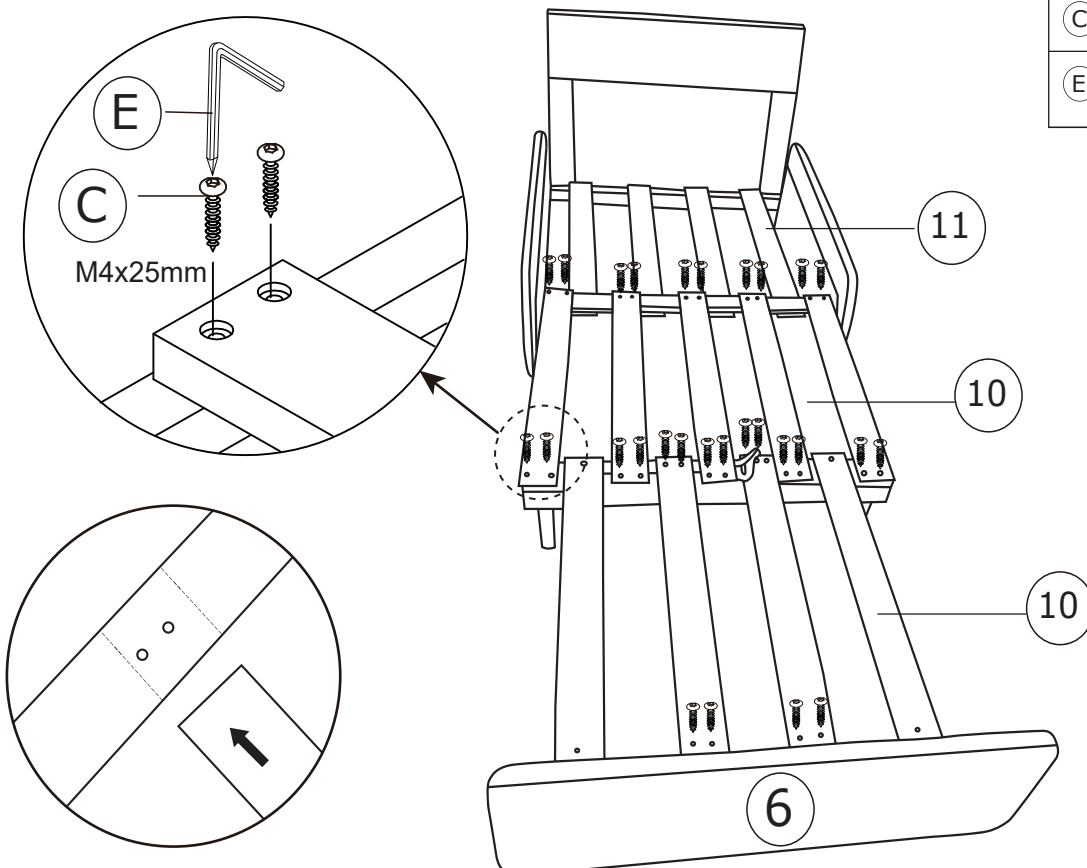

8

6		x1
10	 62cm	x1
C	 M4x25mm	x28
E		x1



9

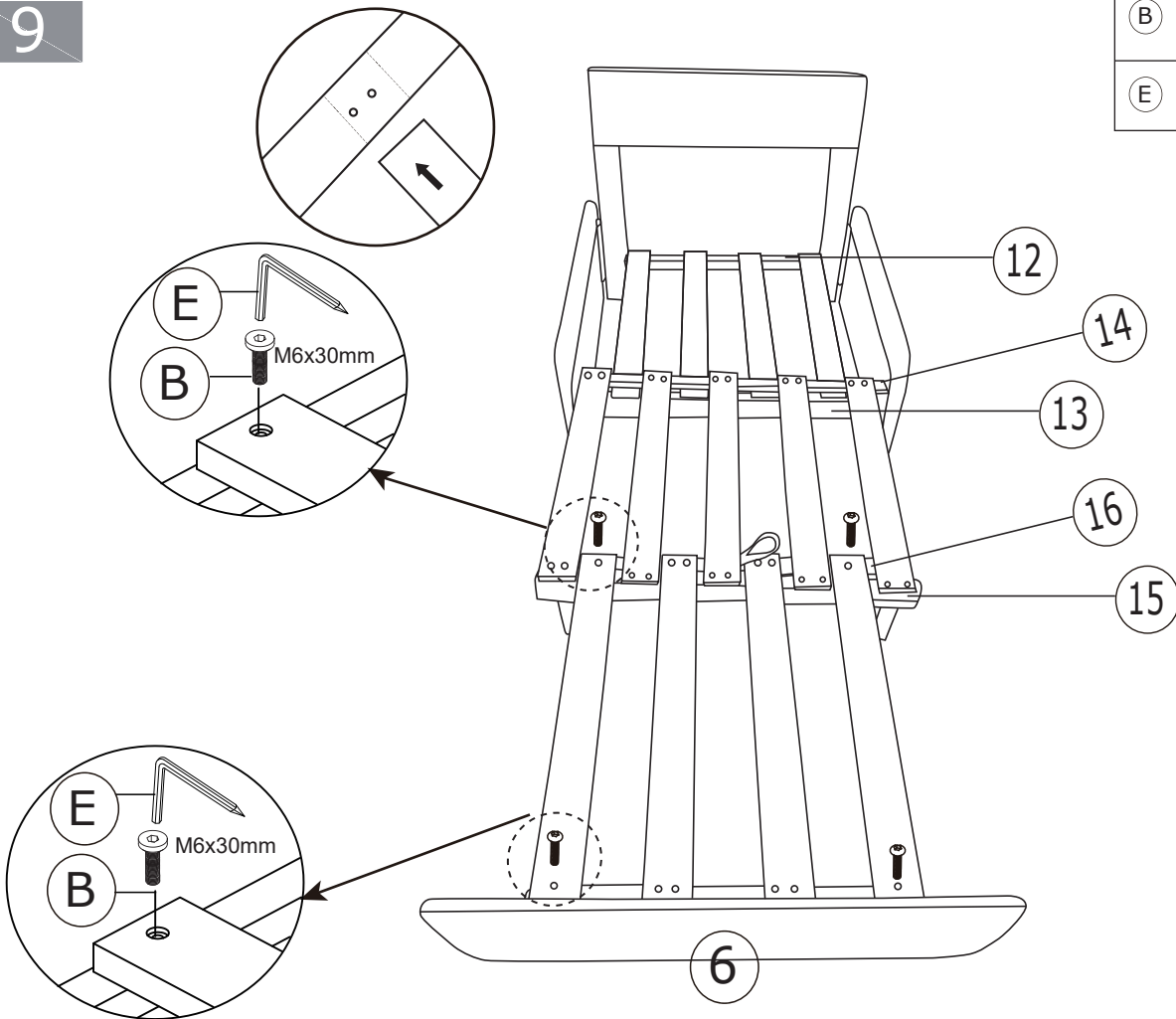

B	 M6x30mm	x4
E		x1

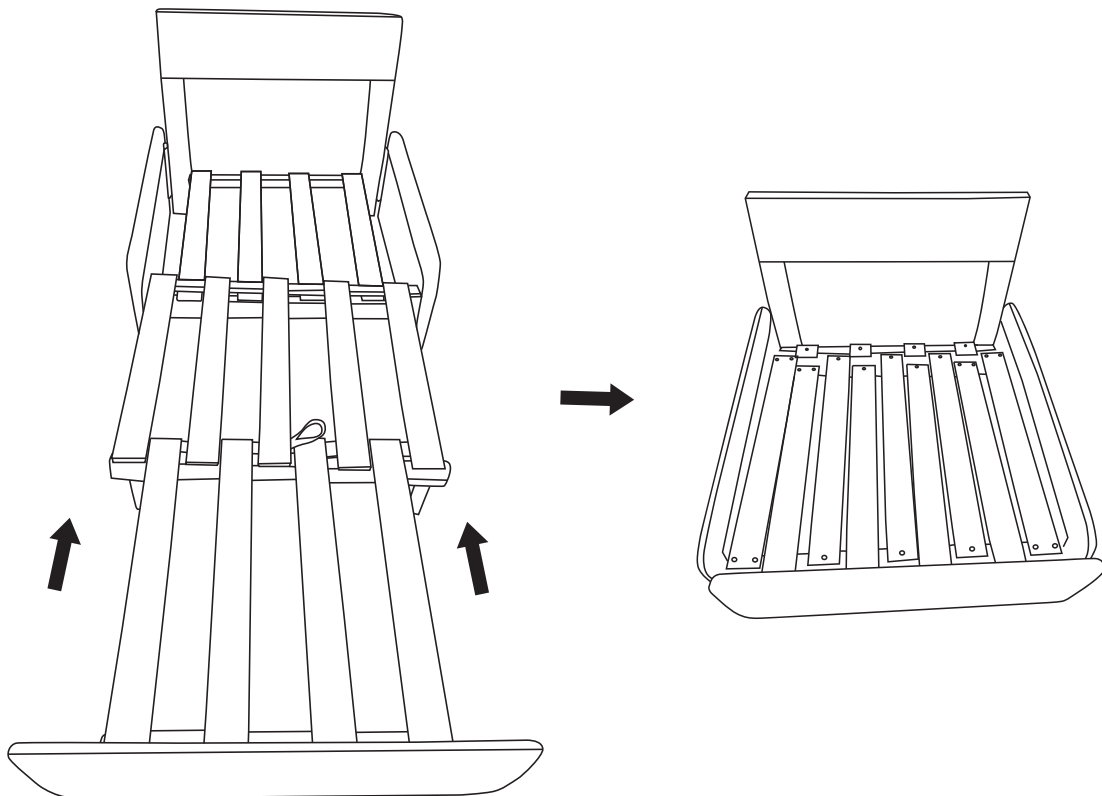

10



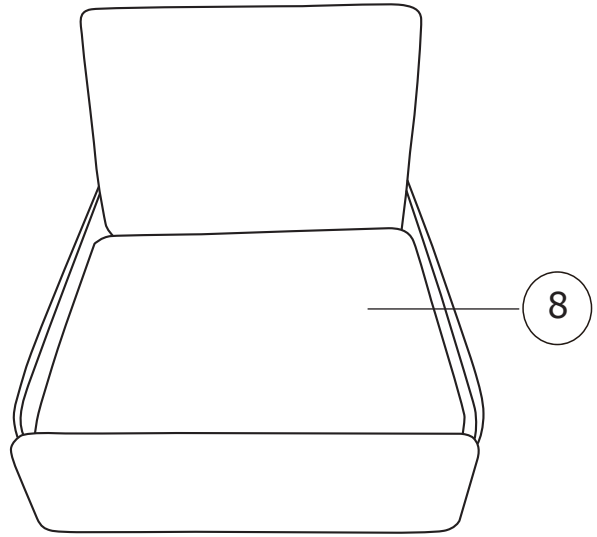
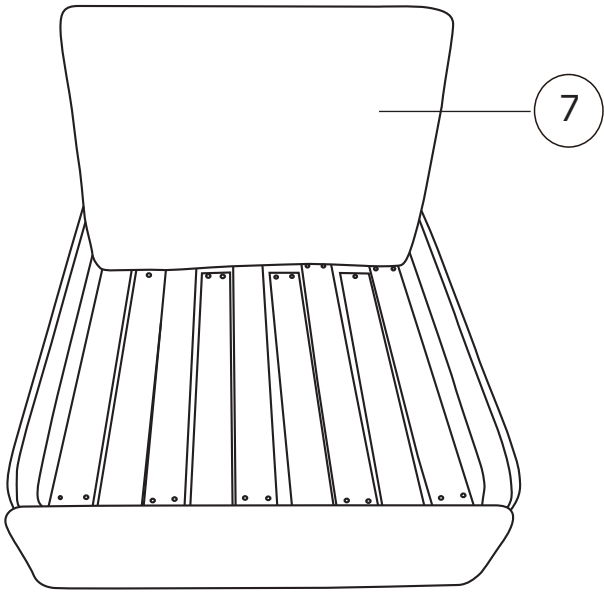

11

7		x1
8		x1



12

4		x1
5		x1

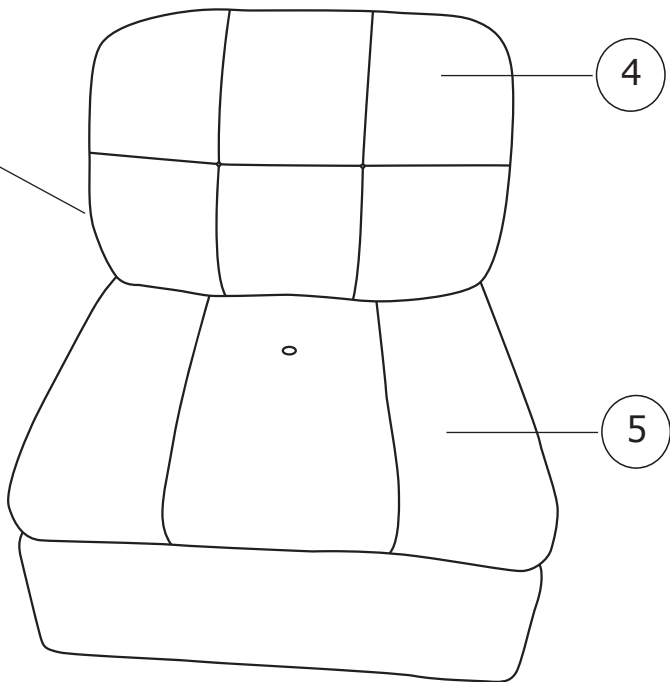
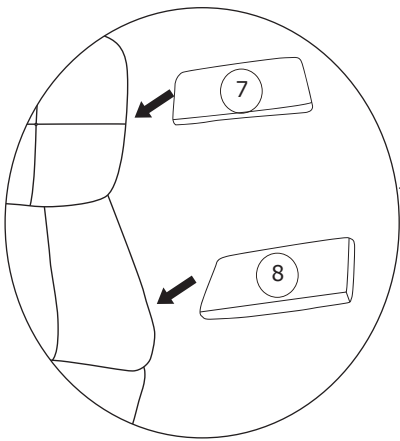

13

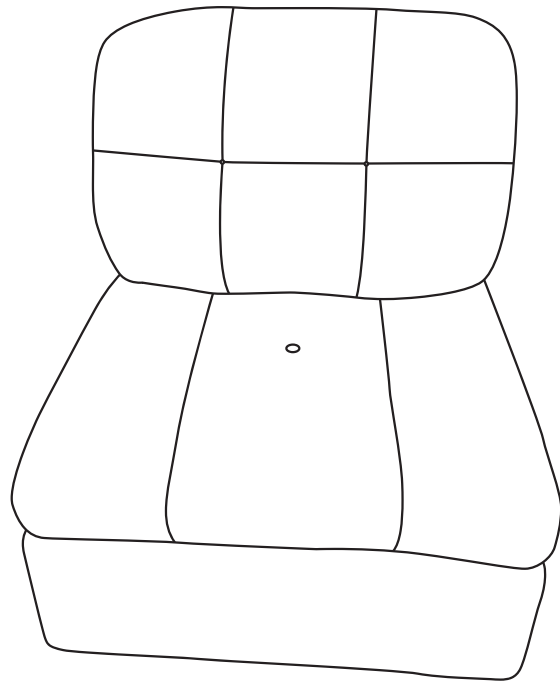

14

