

Installationsanleitung Installation Instruction Instruction d'installation

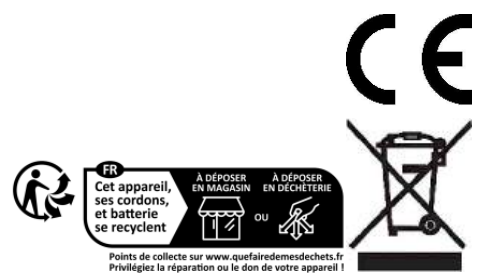
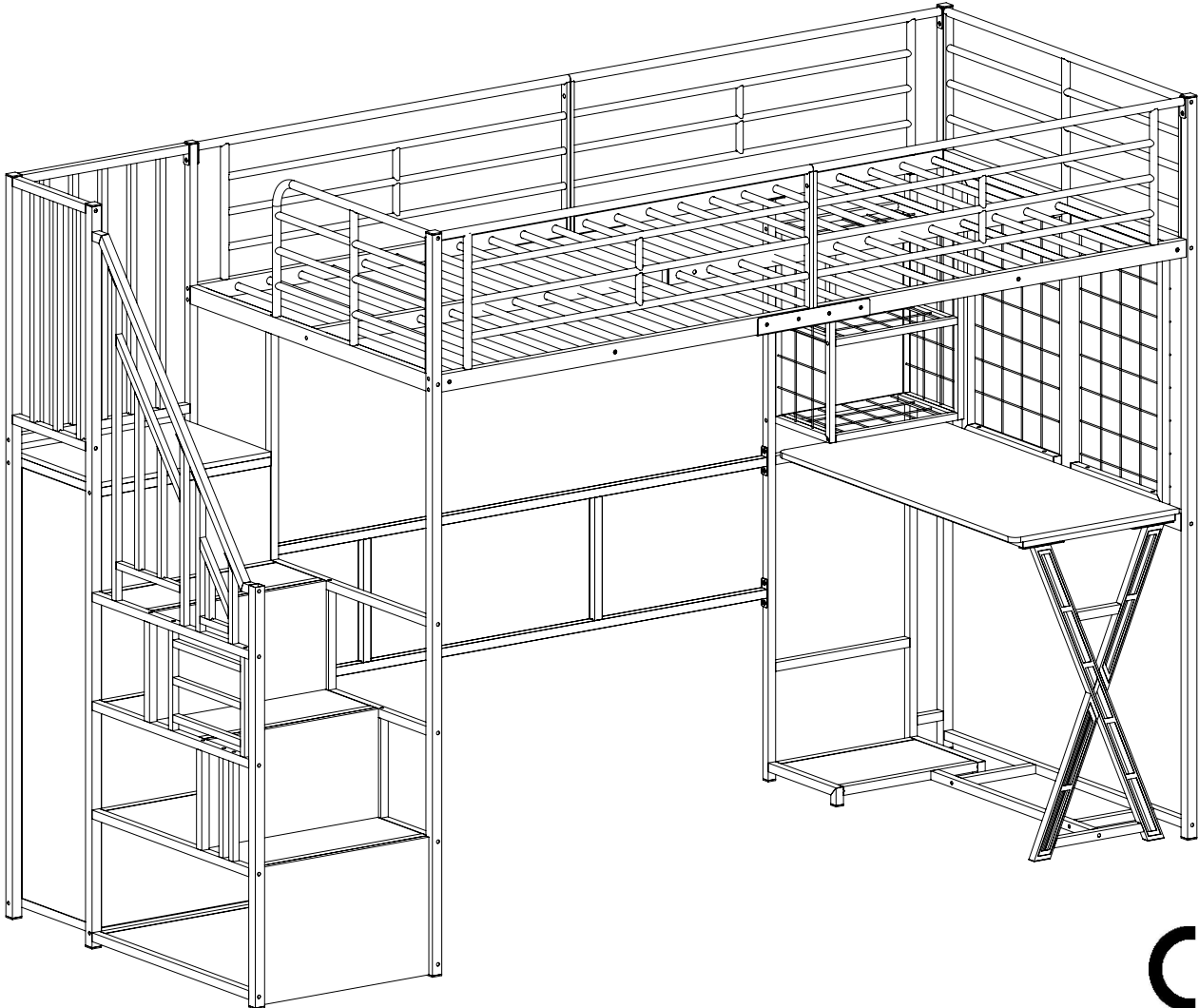

Unser Produkt wird Ihnen in 3 Paketen geliefert. Die Lieferzeiten dieser 3 Pakete können abweichen, bitte haben Sie etwas Geduld und vielen Dank für Ihr Verständnis.

Our product will be delivered to you in 3 packages. The delivery times of these 3 packages may differ, please be patient and thank you for your understanding.

Notre produit vous sera livré en 3 colis. Les délais de livraison de ces 3 colis peuvent différer, soyez patient et merci pour votre compréhension.

N636P249103-N636P249104-N636P249105

ANLEITUNG

WICHTIG - SORGFÄLTIG DURCHLESEN – FÜR

ZUKÜNFTIGE REFERENZ BEWAHREN

- a) **WARNUNG** - Hochbetten und das Oberbett von Etagenbett sind wegen der Verletzungsgefahr durch Stürze nicht für Kinder unter sechs Jahren geeignet.
- b) **WARNUNG** - Etagenbetten und Hochbetten können ein ernstes Verletzungsrisiko darstellen, wenn sie nicht ordnungsgemäß verwendet werden. Befestigen oder hängen Sie niemals Gegenstände an einem Teil des Etagenbetts, die nicht für die Verwendung mit dem Bett vorgesehen sind, zum Beispiel Schnüre, Kordeln, Haken, Gurte und Taschen.
- c) **WARNUNG** - Kinder können zwischen Bett und Wand eingeklemmt werden. Um die Gefahr schwerer Verletzungen zu vermeiden, darf der Abstand zwischen der oberen Sicherheitsbarriere und der angrenzenden Konstruktion 75 mm nicht überschreiten oder mehr als 230 mm betragen.
- d) **WARNUNG** - Verwenden Sie das Etagenbett / Hochbett nicht, wenn ein Bauteil beschädigt ist oder fehlt. Ersatzteile werden zwischendurch beim Hersteller oder beim Händler angefordert.
- e) Befolgen Sie unbedingt die Installationsanweisungen und die Gebrauchsanweisung des Herstellers.
- f) Die empfohlene Größe der Matratze für das Bett beträgt 200 cm x 90 cm, maximale Dicke der Matratze: 13 cm.
- g) Es ist notwendig, den Raum zu lüften, um ein niedriges Feuchtigkeitsniveau aufrechtzuerhalten und das Wachstum von Schimmel im Bett und an dessen Peripherie zu verhindern.
- h) Verbindungselemente sollten immer richtig angezogen und regelmäßig überprüft werden. Bei Bedarf festziehen.

INSTRUCTIONS

IMPORTANT - READ CAREFULLY - RETAIN FOR FUTURE

REFERENCE

- a) **WARNING** - High beds and the upper bed of bunk beds are not suitable for children under six years due to the risk of injury from falls;
- b) **WARNING** - Bunk beds and high beds can present a serious risk of injury from strangulation if not used correctly. Never attach or hang items to any part of the bunk bed that are not designed to be used with the bed, for example, but not limited to ropes, strings, cords, hooks, belts and bags.
- c) **WARNING** - Children can become trapped between the bed and the wall, a roof pitch, the ceiling adjoining pieces of furniture (e.g. cupboards) and the like. To avoid risk of serious injury the distance between the top safety barrier and the adjoining structure shall not exceed 75 mm or shall be more than 230 mm.
- d) **WARNING** - Do not use the bunk bed/high bed if any structural part is broken or missing; Replacement parts are between requested from the manufacturer or the store.
- e) it is imperative to always follow the installation instructions and manufacturer's use.
- f) The recommended size of the mattress to be used with the bed is 200cm x 90cm, maximum thickness mattress: 13cm.
- g) It is necessary to ventilate the room in order to maintain a low level moisture and prevent mold growth in the bed and its periphery.
- h) Joining devices should always be tightened properly and regularly verified. Tighten if necessary.

INSTRUCTIONS

IMPORTANT - À LIRE ATTENTIVEMENT - CONSERVER

POUR RÉFÉRENCE ULTÉRIEURE

- a) **AVERTISSEMENT** - Les lits surélevés et le lit supérieur des lits superposés ne conviennent pas aux enfants de moins de six ans en raison du risque de blessure dû à une chute;
- b) **AVERTISSEMENT** - Les lits superposés et les lits surélevés peuvent présenter un risque sérieux de blessure par strangulation s'ils ne sont pas utilisés correctement. Ne jamais attacher ou suspendre à des parties du lit superposé des objets qui ne sont pas conçus pour être utilisés avec le lit, par exemple, mais ne se limitant pas à des cordes, des ficelles, des cordes, des crochets, des ceintures et des sacs.
- c) **AVERTISSEMENT** - Les enfants peuvent rester coincés entre le lit et le mur, un toit incline les meubles adjacents au plafond (par exemple, des armoires), etc. Pour éviter tout risque de blessure grave, la distance entre la barrière de sécurité supérieure et la structure adjacente ne doit pas dépasser 75 mm ou doit être supérieure à 230 mm.
- d) **AVERTISSEMENT** - N'utilisez pas le lit superposé / le lit surélevé si une partie de la structure est cassée ou manquante. Les pièces de rechange sont demandées au fabricant ou au magasin.
- e) il est impératif de toujours suivre les instructions d'installation et l'utilisation du fabricant.
- f) La taille recommandée du matelas à utiliser avec le lit est 200 cm x 90 cm, épaisseur maximale du matelas: 13 cm.
- g) Il est nécessaire de ventiler la pièce afin de maintenir un faible niveau d'humidité et d'empêcher la formation de moisissure dans le lit et à sa périphérie.
- h) Les dispositifs de jonction doivent toujours être correctement serrés et vérifiés régulièrement. Serrer si nécessaire.

ISTRUZIONI

IMPORTANTE - LEGGERE ATTENTAMENTE -

CONSERVARE IL FUTURO RIFERIMENTO

- a) **ATTENZIONE** - I letti alti e il letto superiore a castello non sono adatti a bambini di età inferiore ai sei anni a causa del rischio di lesioni da cadute;
- b) **AVVERTENZA** - I letti a castello e i letti alti possono presentare un serio rischio di lesioni a causa di strangolamento se non utilizzati correttamente. Non attaccare o appendere mai oggetti a qualsiasi parte del letto a castello che non sono progettati per essere utilizzati con il letto, ad esempio, ma non limitato a corde, corde, corde, ganci, cinture e borse.
- c) **AVVERTENZA** - I bambini possono rimanere intrappolati tra il letto e la parete, un tetto inclinato il mobile adiacente al soffitto (ad es. armadi) e simili. Per evitare il rischio di gravi lesioni, la distanza tra la barriera di sicurezza superiore e a struttura adiacente non deve superare 75 mm o deve essere superiore a 230 mm.
- d) **ATTENZIONE** - Non utilizzare il letto a castello / letto alto se qualche parte strutturale è rotta o mancante; Le parti di ricambio sono tra quelle richieste al produttore o al negozio.
- e) è indispensabile seguire sempre le istruzioni di installazione e l'uso del produttore.
- f) Le dimensioni consigliate del materasso da utilizzare con il letto sono 200 cm x 90 cm, materasso di massimo spessore: 13 cm.
- g) È necessario ventilare l'ambiente per mantenere un'umidità bassa e prevenire la formazione di muffe nel letto e nella sua periferia.
- h) I dispositivi di giunzione devono essere sempre serrati correttamente e regolarmente verificati. Stringere se necessario.

INSTRUCTIES

BELANGRIJK - LEES AANDACHTIG - BEWAAR VOOR TOEKOMSTIGE REFERENTIE

- a) **WAARSCHUWING** - Hoge bedden en het bovenste bed van stapelbedden zijn niet geschikt voor kinderen jonger dan zes jaar vanwege het risico op letsel door vallen;
- b) **WAARSCHUWING** - Stapelbedden en hoge bedden kunnen een ernstig risico op verwonding vormen als ze niet correct worden gebruikt. Bevestig of hang nooit items aan een deel van het stapelbed die niet zijn ontworpen voor gebruik met het bed, bijvoorbeeld, maar niet beperkt tot touwen, koorden, koorden, haken, riemen en tassen.
- c) **WAARSCHUWING** - Kinderen kunnen vast komen te zitten tussen het bed en de muur, een dakhelling het plafond aangrenzende meubels (bijv. kasten) en dergelijke. Om het risico van ernstig letsel te voorkomen, mag de afstand tussen de bovenste veiligheidsbarrière en de aangrenzende structuur niet groter zijn dan 75 mm of meer dan 230 mm.
- d) **WAARSCHUWING** - Gebruik het stapelbed / hoogbed niet als een structureel onderdeel kapot is of ontbreekt; Vervangende onderdelen worden tussen gevraagd door de fabrikant of de winkel.
- e) het is noodzakelijk om altijd de installatie-instructies en het gebruik van de fabrikant te volgen.
- f) De aanbevolen maat van de matras die met het bed wordt gebruikt, is 200 cm x 90 cm, maximale dikte matras: 13 cm.
- g) Het is noodzakelijk om de kamer te ventileren om een laag vochtgehalte te handhaven en schimmelgroei in het bed en de periferie ervan te voorkomen.
- h) Verbindingsinrichtingen moeten altijd goed worden vastgedraaid en regelmatig worden gecontroleerd. Draai indien nodig vast.

INSTRUKCE

DŮLEŽITÉ - PŘEČTĚTE SI POZORNĚ - UCHOVÁVAJTE PRO BUDOUCÍ REFERENCE

- a) **VAROVÁNÍ** - vysoké postele a horní lůžka palandy nejsou vhodné pro děti do šesti let z důvodu rizika zranění pádem;
- b) **VAROVÁNÍ** - Patrové postele a vysoké postele mohou představovat vážné riziko zranění při úskrcení, pokud nebudou správně použity. Nikdy nepřípevňujte ani nezavěšujte předměty na žádnou část palandy, které nejsou navrženy pro použití s postelí, ale neomezují se pouze na lana, provázky, šňůry, háčky, pásy a tašky.
- c) **VÝSTRAHA** - Děti se mohou zachytit mezi postel a zeď, sklonit střechu stropy přilehlé kusy nábytku (např. skříně) a podobně. Aby se zabránilo riziku vážného zranění, nesmí vzdálenost mezi horní bezpečnostní bariérou a sousední konstrukcí překročit 75 mm nebo být větší než 230 mm.
- d) **VÝSTRAHA** - Nepoužívejte patrové lůžko / vysoké lůžko, pokud je některá konstrukční část zlomená nebo chybí; Náhradní díly jsou mezi na vyžádání od výrobce nebo obchodu.
- e) je bezpodmínečně nutné dodržovat instalační pokyny a použití výrobcem.
- f) Doporučená velikost matrace pro použití s postelí je 200 cm x 90 cm, maximální tloušťka matrace: 13 cm.
- g) Místnost je nutné ventilovat, aby se udržela nízká hladina vlhkosti a zabránilo se růstu plísní v loži a jeho obvodu.
- h) Spojovací zařízení by měla být vždy pevně dotažena a pravidelně ověřována. V případě potřeby dotáhněte.

IINSTRUKCJE

WAŽNE - PRZECZYTAJ UWAŻNIE - ZACHOWAJ NA PRZYSZŁOŚĆ

- a) **OSTRZEŻENIE** - Wysokie łóżka i górne łóżko łóżek piętrowych nie są odpowiednie dla dzieci poniżej sześciu lat ze względu na ryzyko obrażeń w wyniku upadku;
- b) **OSTRZEŻENIE** - Łóżka piętrowe i wysokie łóżka mogą stwarzać poważne ryzyko obrażeń na skutek uduszenia, jeśli nie zostaną właściwie użyte. Nigdy nie mocuj ani nie wieszaj przedmiotów na żadnej części łóżka piętrowego, które nie są przeznaczone do użytku z łóżkiem, na przykład, ale nie ograniczając się do lin, sznurków, sznurków, haczyków, pasów i toreb.
- c) **OSTRZEŻENIE** - Dzieci mogą zostać uwięzione między łóżkiem a ścianą, nachyleniem dachu pod sufitem przylegającymi meblami (np. szafkami) i tym podobne. Aby uniknąć ryzyka poważnych obrażeń, odległość między górną barierą bezpieczeństwa a przylegającą konstrukcją nie może przekraczać 75 mm lub być większa niż 230 mm.
- d) **OSTRZEŻENIE** - Nie używaj łóżka piętrowego / wysokiego łóżka, jeśli jakkolwiek część konstrukcyjna jest zepsuta lub brakuje jej; Części zamienne są wymagane od producenta lub sklepu.
- e) bezwzględnie należy przestrzegać instrukcji instalacji i użytkowania producenta.
- f) Zalecany rozmiar materaca do zastosowania z łóżkiem to 200 cm x 90 cm, maksymalna grubość materaca: 13cm.
- g) Konieczna jest wentylacja pomieszczenia w celu utrzymania niskiego poziomu wilgoci i zapobiegania rozwojowi pleśni w łóżku i jego obrzeżach.
- h) Urządzenia łączące powinny być zawsze odpowiednio dokręcone i regularnie sprawdzane. Dokręć w razie potrzeby.

INŠTRUKCIE

DŔLEŽITÉ - POZORNE SI PREČÍTAJTE - UCHOVÁVAJTE PRE BUDÚCE REFERENCIE

- a) **VÝSTRAHA** - Vysoké postele a horné postele poschodových postelí nie sú vhodné pre deti do šiestich rokov kvôli riziku zranenia pádom;
- b) **VÝSTRAHA** - poschodové postele a vysoké postele môžu predstavovať vážne riziko zranenia priškrcením, ak sa nebudú správne používať. Nikdy nepripevňujte ani nevešajte predmety k žiadnej časti poschodovej postele, ktorá nie je určená na použitie s posteľou, napríklad, ale nielen, laná, šnúry, šnúry, háčiky, pásy a tašky.
- c) **VÝSTRAHA** - Deti sa môžu zachytiť medzi posteľou a stenou, sklonom strechy, stropom prílehlým kusom nábytku (napr. skrinky) a podobne. Aby sa predišlo riziku vážneho zranenia, vzdialenosť medzi hornou bezpečnostnou bariérou a príslušnou konštrukciou nesmie prekročiť 75 mm alebo byť viac ako 230 mm.
- d) **VÝSTRAHA** - Nepoužívajte poschodovú posteľ / vysoké lôžko, ak je akákoľvek konštrukčná časť poškodená alebo chýba; Náhradné diely sú potrebné na vyžiadanie od výrobcu alebo skladu.
- e) je bezpodmienečne nutné postupovať podľa pokynov na inštaláciu a podľa pokynov výrobcu.
- f) Odporúčaná veľkosť matrace použitého na lôžko je 200 cm x 90 cm, maximálna hrúbka matrace: 13 cm.
- g) Miestnosť je potrebné vetrať, aby sa udržala nízka úroveň vlhkosti a zabránilo sa rastu plesní v lôžku a jeho obvode.
- h) Spojovacie zariadenia by sa mali vždy pevne dotiahnuť a pravidelne preverovať. V prípade potreby dotiahnite.

UTASÍTÁS

FONTOS - OLVASSA EL FIGYELMESEN - VÁRJON A JÖVŐBEN

- a) **VIGYÁZAT** - A magas ágyak és az emeletes ágyak felső ágya nem alkalmas hat év alatti gyermekek számára az esések sérülésének veszélye miatt;
- b) **FIGYELMEZTETÉS** - Az emeletes ágyak és a magas ágyak súlyos sérülést okozhatnak a fojtogatás következtében, ha nem használják helyesen. Soha ne csatlakoztasson és ne lógjon az emeletes ágy olyan részeire, amelyeket például nem az ágyhoz való felhasználásra terveztek, de ezekre nem korlátozódnak: kötelek, húrok, zsinórok, horgok, övek és táskák.
- c) **FIGYELMEZTETÉS** - A gyermekek becsapódhatnak az ágy és a fal közé, tetőtéri a mennyezetet a szomszédos bútorokhoz (például szekrényekhez) és hasonlókat. A súlyos sérülés kockázatának elkerülése érdekében a felső biztonsági akadály és a szomszédos szerkezet közötti távolság nem haladhatja meg a 75 mm-t vagy több, mint 230 mm.
- d) **FIGYELMEZTETÉS** - Ne használja az emeletes ágyat / magas ágyat, ha valamelyik szerkezeti elem törött vagy hiányzik; A cserealkatrészeket a gyártótól vagy a bolttól kérheti.
- e) feltétlenül kövesse a telepítési utasításokat és a gyártó általi felhasználást.
- f) Az ágyhoz használni kívánt matrac ajánlott mérete 200 cm x 90 cm, a matrac maximális vastagsága: 13 cm.
- g) Szellőztetni kell a helyiséget, hogy fennmaradjon az alacsony nedvességtartalom, és megakadályozzák a penész növekedését az ágyban és annak peremén.
- h) A csatlakozóberendezéseket mindig megfelelően meg kell húzni és rendszeresen ellenőrizni kell. Szükség esetén húzza meg.

TALÍMATLAR

ÖNEMLİ - DİKKATLE OKUYUN - GELECEK REFERANS İÇİN TUTUN

- a) **UYARI** - Yüksek yataklar ve ranzaların üst yatağı, düşme nedeniyle yaralanma tehlikesi nedeniyle altı yaşın altındaki çocuklar için uygun değildir;
- b) **UYARI** - Ranzalar ve yüksek yataklar, doğru kullanılmadığı takdirde boğulma nedeniyle ciddi yaralanma riski oluşturabilir. Hiçbir zaman ranza yatağının, yatakları birlikte kullanılmak üzere tasarlanmamış, ancak ipler, ipler, kordonlar, kancalar, kayışlar ve çantalar ile sınırlı olmamak üzere herhangi bir parçasına takmayın veya asılmayın.
- c) **UYARI** - Çocuklar yatakları duvar arasında sıkışıp kalabilir, tavana bitişik mobilya parçaları (örneğin dolaplar) ve benzeri bir tavan döşenir. Ciddi yaralanma riskini önlemek için üst güvenlik bariyeri ve bitişik yapı arasındaki mesafe 75 mm'yi geçmemelidir veya 230 mm'den fazla olmalıdır.
- d) **UYARI** - Herhangi bir yapısal parça kırılmış veya eksikse ranza / yüksek yatak kullanmayın; Yedek parçaları üretici veya mağazadan talep arasındadır.
- e) her zaman kurulum talimatlarını ve üreticinin kullanımını takip etmek zorunludur.
- f) Yatak ile birlikte kullanılması tavsiye edilen yatak boyutu 200 cm x 90 cm, maksimum kalınlık yatağı: 13 cm'dir.
- g) Düşük seviyede nem sağlamak ve yatak ve çevresinde küf oluşumunu önlemek için odanın havalandırılması gerekir.
- h) Birleştirme cihazları her zaman uygun şekilde sıkılmalı ve düzenli olarak kontrol edilmelidir. Gerekirse sıkın.

INSTRUCȚIUNI

IMPORTANT - CITIȚI CU ATENȚIE - PĂȚIȚI PENTRU REFERINȚĂ VIITORĂ

- a) **AVERTIZARE** - Paturile înalte și patul superior al paturilor nu sunt potrivite pentru copiii sub șase ani din cauza riscului de rănire din cauza căderilor;
- b) **AVERTIZARE** - Paturile suprapuse și paturile înalte pot prezenta un risc grav de rănire din cauza strangulării dacă nu sunt utilizate corect. Nu atașați și nu agățați niciodată articole pe nicio parte a patului care nu sunt concepute pentru a fi utilizate cu patul, de exemplu, dar fără a se limita la frânghii, corzi, șnururi, cârlige, curele și saci.
- c) **AVERTIZARE** - Copiii pot deveni prinși între pat și perete, pot acoperi acoperișul pe piesele de mobilier alăturate (de ex. dulapuri) și altele asemenea. Pentru a evita riscul de rănire gravă, distanța dintre bariera de siguranță superioară și structura alăturată nu trebuie să depășească 75 mm sau să fie mai mare de 230 mm.
- d) **AVERTIZARE** - Nu folosiți patul supraetajat / patul înalt dacă o parte structurală este ruptă sau lipsește; Piesele de schimb se fac între solicitarea producătorului sau a magazinului.
- e) este obligatoriu să respectați întotdeauna instrucțiunile de instalare și utilizarea producătorului.
- f) Dimensiunea recomandată a saltelei care va fi folosită cu patul este de 200cm x 90cm, grosimea maximă a saltelei: 13 cm.
- g) Este necesară ventilarea camerei pentru a menține o umiditate la nivel scăzut și a preveni creșterea mușcăiului în pat și la periferia acesteia.
- h) Dispozitivele de îmbinare trebuie întinse întotdeauna corect și verificate regulat. Strângeți dacă este necesar.

ИНСТРУКЦИИ

ВАЖНО - ПРОЧИТАЙТЕ ВНИМАТЕЛЬНО - СОХРАНИТЕ БУДУЩУЮ ССЫЛКУ

- a) **ПРЕДУПРЕЖДЕНИЕ** - Высокие кровати и верхняя кровать двухъярусных кроватей не подходят для детей младше шести лет из-за риска получения травмы в результате падения;
- b) **ПРЕДУПРЕЖДЕНИЕ** - двухъярусные кровати и высокие кровати могут представлять серьезную опасность травмирования от удушья, если их неправильно использовать. Никогда не прикрепляйте и не подвешивайте предметы к какой-либо части двухъярусной кровати, например, которые не предназначены для использования с кроватью, но не ограничиваются веревками, веревками, шнурами, крючками, ремнями и сумками.
- c) **ПРЕДУПРЕЖДЕНИЕ** - Дети могут оказаться в ловушке между кроватью и стеной, крышей, наклонить потолок к смежным предметам мебели (например, шкафом) и т.п. Во избежание риска получения серьезных травм расстояние между верхним защитным барьером и прилегающей конструкцией не должно превышать 75 мм или должно быть более 230 мм.
- d) **ПРЕДУПРЕЖДЕНИЕ** не используйте двухъярусную кровать / высокую кровать, если какая-либо конструктивная часть сломана или отсутствует; Запасные части между запросами от производителя или магазина.
- e) обязательно всегда следовать инструкциям по установке и использованию изготовителем.
- f) Рекомендуемый размер матраса, который будет использоваться с кроватью, составляет 200см x 90см, максимальная толщина матраса: 13 см.
- g) Необходимо проветривать помещение, чтобы поддерживать низкий уровень влаги и предотвращать образование плесени в ложе и на его периферии.
- h) Соединительные устройства всегда должны быть надежно затянуты и регулярно проверяться. Затянуть при необходимости.

English

IMPORTANT ! KEEP FOR FUTURE REFERENCE : READ CAREFULLY

- To be assembled by an adult. Assembly must be checked by an adult before use
- **WARNING!** Keep all screws, small parts and plastic bags out of the reach of children
- Properly identify all parts before assembling
- Never use your item if any of its parts are broken or missing
- Should any problems arise, please contact our After Sales Service
- Manufacturer's instructions shall be followed at all times
- Care: Clean with a soft, dry cloth. In case of larger stains, carefully rub with a slightly damp, non- abrasive sponge
- Avoid the risk of fire by not placing furniture near sources of ignition or hot items
- Do not jump on the bed

Deutsch

WICHTIG! ZUM SPÄTEREN NACHSCHLAGEN AUFBEWAHREN: SORGFÄLTIG LESEN

- Muss von einem Erwachsenen zusammengebaut werden. Der Zusammenbau muss vor dem Gebrauch von einem Erwachsenen überprüft werden
- **WARNUNG!** Bewahren Sie alle Schrauben, Kleinteile und Plastikbeutel außerhalb der Reichweite von Kindern auf
- Kennzeichnen Sie vor dem Zusammenbau alle Teile richtig
- Benutzen Sie Ihren Artikel niemals, wenn Teile gebrochen sind oder fehlen
- Sollten Probleme auftreten, wenden Sie sich bitte an unseren Kundendienst
- Die Anweisungen des Herstellers sind stets zu befolgen
- Pflege: Mit einem weichen, trockenen Tuch reinigen. Bei größeren Flecken vorsichtig mit einem leicht feuchten, nicht scheuernden Schwamm abreiben. nicht scheuernden Schwamm
- Vermeiden Sie die Gefahr eines Brandes, indem Sie die Möbel nicht in der Nähe von Zündquellen oder heißen Gegenständen aufstellen
- Nicht auf das Bett springen

Français

IMPORTANT! CONSERVER POUR RÉFÉRENCE ULTÉRIEURE: LIRE ATTENTIVEMENT

- Le montage doit être effectué par un adulte. Le montage doit être vérifié par un adulte avant utilisation
- **ATTENTION!** Tenir les vis, les petites pièces et les sachets en plastique hors de portée des enfants
- Identifiez correctement toutes les pièces avant de les assembler
- N'utilisez jamais votre article si l'une de ses pièces est cassée ou manquante
- En cas de problème, veuillez contacter notre service après-vente
- Les instructions du fabricant doivent être respectées à tout moment
- Entretien: nettoyer avec un chiffon doux et sec. En cas de taches plus importantes, frotter soigneusement avec une éponge non abrasive légèrement humide. légèrement humide et non abrasive
- Évitez les risques d'incendie en ne plaçant pas les meubles à proximité de sources d'inflammation ou d'objets chauds
- Ne pas sauter sur le lit

- Deve essere assemblato da un adulto. L'assemblaggio deve essere controllato da un adulto prima dell'uso
- **ATTENZIONE!** Tenere tutte le viti, le piccole parti e i sacchetti di plastica fuori dalla portata dei bambini
- Identificare correttamente tutte le parti prima dell'assemblaggio
- Non utilizzare mai l'articolo se alcune parti sono rotte o mancanti
- In caso di problemi, si prega di contattare il nostro Servizio Post Vendita
- Le istruzioni del produttore devono essere sempre seguite
- Cura: Pulire con un panno morbido e asciutto. In caso di macchie più estese, strofinare accuratamente con una spugna leggermente umida e non spugna leggermente umida e non abrasiva
- Evitare il rischio di incendio, non collocando i mobili vicino a fonti di accensione o a oggetti caldi
- Non saltare sul letto

- Debe ser montado por un adulto. El montaje debe ser comprobado por un adulto antes del uso
- **ADVERTENCIA** Mantenga todos los tornillos, piezas pequeñas y bolsas de plástico fuera del alcance de los niños
- Identifique correctamente todas las piezas antes de montarlas
- Nunca utilice su artículo si alguna de sus piezas está rota o falta
- Si surge algún problema, póngase en contacto con nuestro Servicio Postventa
- Las instrucciones del fabricante deben seguirse en todo momento
- Cuidado: Limpiar con un paño suave y seco. En caso de manchas más grandes, frote cuidadosamente con una esponja no abrasiva ligeramente humedecida
- Evite el riesgo de incendio no colocando los muebles cerca de fuentes de ignición u objetos calientes
- No saltar sobre la cama

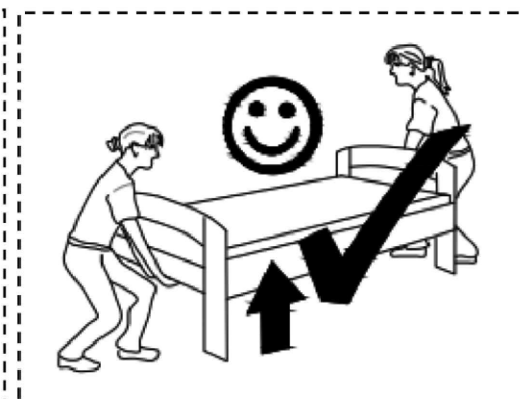
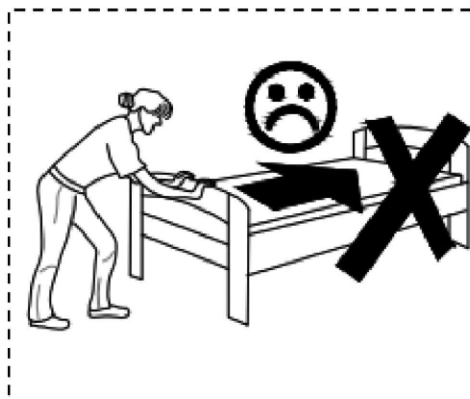





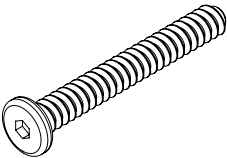
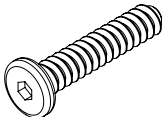

Vor dem Einbau die Schrauben in die Löcher stecken und festziehen, aber nicht bis 100%, 70% bis 80% anziehen reicht aus. Schließlich, nachdem alle Schrauben installiert sind, ziehen Sie alle Schrauben auf 100%. Wenn Sie auf diese Probleme stoßen, wie z. B. Fehlausrichtung der Löcher oder Unfähigkeit, bestimmte Teile zu installieren, überprüfen Sie bitte, ob die Schrauben korrekt verwendet werden und passen Sie die Dichtigkeit der Schrauben an.

Before installation, insert the screws into the holes and tighten them, but do not tighten them to 100%, 70% to 80% is sufficient. Finally, after all screws are installed, tighten all screws to 100%. If you encounter these issues, such as if the holes cannot be aligned or some parts cannot be installed, please check if the screws are used correctly and adjust the tightness of the screws.

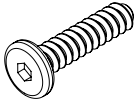
Insérer la vis dans le trou avant la fin de l'assemblage, serrer la vis, mais ne pas serrer à 100%, 70% ~ 80% est correct. Enfin, une fois que toutes les vis sont bien serrées, toutes les vis sont serrées à 100%. Si vous rencontrez ces problèmes, par exemple si les trous ne sont pas alignés ou si certaines pièces ne peuvent pas être montées, vérifiez que les vis sont utilisées correctement et Ajustez leur serrage.

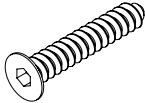
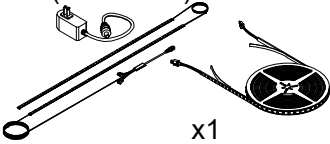
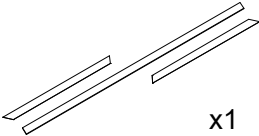
Hardware List For N636P249104

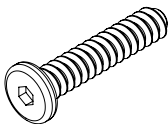
<p>(A) x51</p>  <p>M6*55</p>	<p>(B) x84</p>  <p>M6*35</p>	<p>(C) x30</p>  <p>M6*10</p>	<p>(D) x6</p>  <p>M6*28</p>
<p>(E) x4</p>  <p>M6*15</p>	<p>(F) x60</p>  <p>3.5*10</p>	<p>(G) x2</p>  <p>M6*35</p>	<p>(H) Light strip (Lichtleiste)</p>  <p>x1</p>
<p>(I) Decal Paper (Aufkleberpapier)</p>  <p>x1</p>	<p>(J) x2</p>  <p>4*59</p>	<p>(K) x2</p>  <p>M6*40</p>	

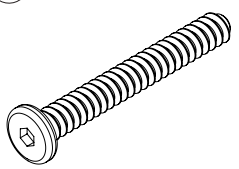
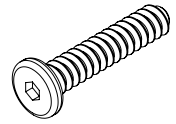
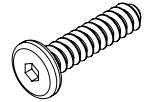
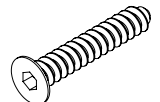
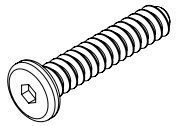
<p>Ⓐ x51</p>  <p>M6*55</p>	<p>Ⓑ x84</p>  <p>M6*35</p>	<p>Ⓓ x6</p>  <p>M6*28</p>	<p>Ⓖ x2</p>  <p>M6*35</p>
<p>Ⓚ x2</p>  <p>M6*40</p>			







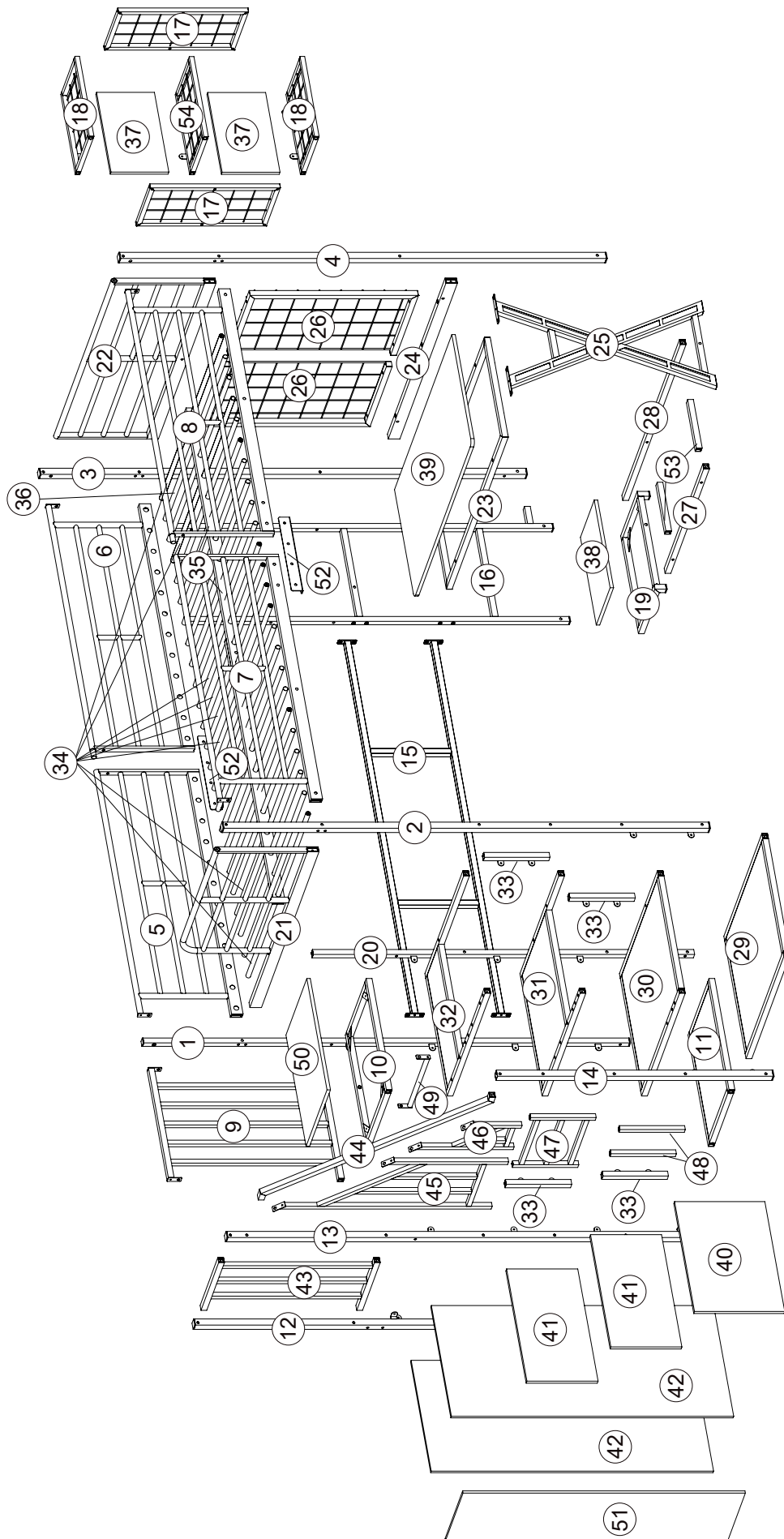





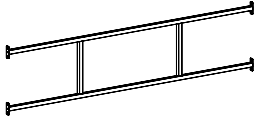

Bitte beachten Sie, dass die Formen der Schrauben a, b, d, g und k ähnlich sind. Bitte installieren Sie entsprechend der Anleitung und unterscheiden Sie sie!

Please note that the shapes of screws a, b, d, g and k are similar. Please install according to the instructions and distinguish them!

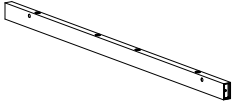
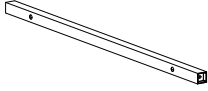
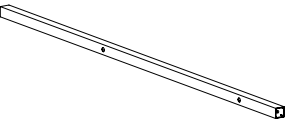

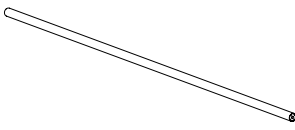
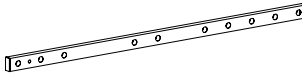
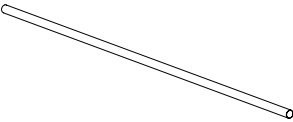
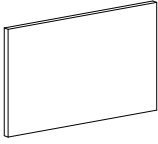

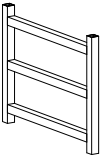

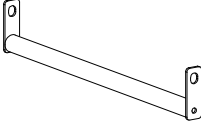
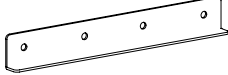
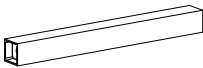
Notez que les vis a, b, d, g et k ont des formes similaires. Veuillez les installer en suivant les instructions pour les séparer!



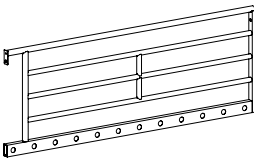
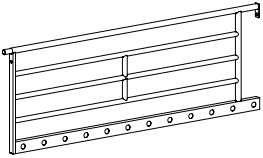
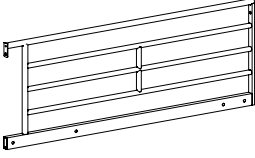
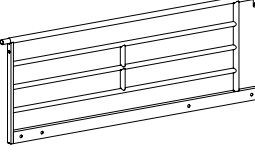
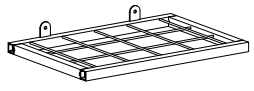
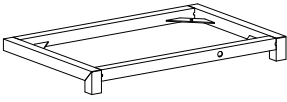
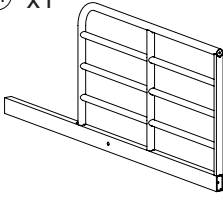
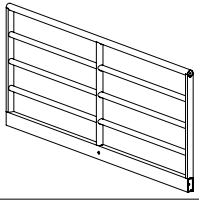
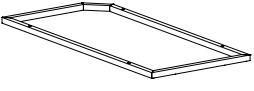
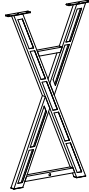
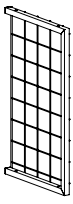

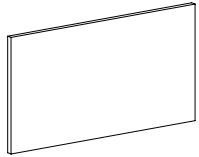
N636P249103

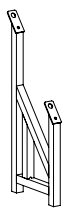
<p>① x1</p> 	<p>② x1</p> 	<p>③ x1</p> 	<p>④ x1</p> 
<p>⑫ x1</p> 	<p>⑬ x1</p> 	<p>⑭ x1</p> 	<p>⑮ x1</p> 
<p>⑰ x2</p> 	<p>⑳ x1</p> 	<p>㉔ x1</p> 	<p>㉗ x1</p> 
<p>㉘ x1</p> 	<p>㉓ x4</p> 	<p>㉖ x8</p> 	<p>㉙ x2</p> 
<p>㉚ x16</p> 	<p>㉞ x2</p> 	<p>㉡ x1</p> 	<p>㉣ x1</p> 
<p>㉧ x1</p> 	<p>㉨ x2</p> 	<p>㉩ x1</p> 	<p>㉫ x2</p> 
<p>㉭ x2</p> 			

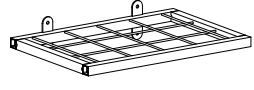
N636P249104

<p>⑤ x1</p> 	<p>⑥ x1</p> 	<p>⑦ x1</p> 	<p>⑧ x1</p> 
<p>⑱ x2</p> 	<p>⑲ x1</p> 	<p>⑳ x1</p> 	<p>㉑ x1</p> 
<p>㉓ x1</p> 	<p>㉕ x1</p> 	<p>㉖ x2</p> 	<p>㉘ x1</p> 
<p>㉑ x2</p> 	<p>㉗ x1</p> 	<p>㉚ x1</p> 	<p>㉙ x1</p> 
<p>㉛ x1</p> 			

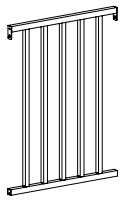
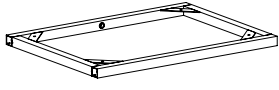
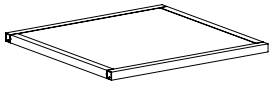
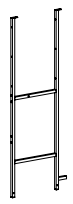
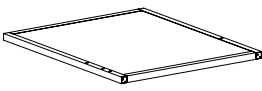
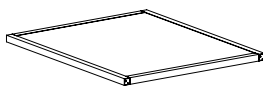
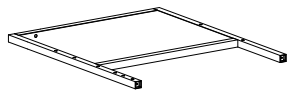
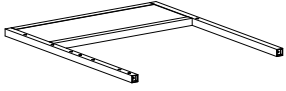
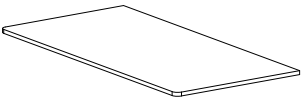
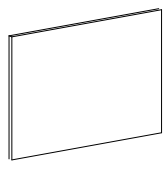
N636P249105

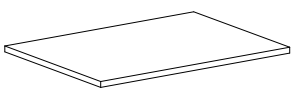
<p>9 x1</p> 	<p>10 x1</p> 	<p>11 x1</p> 	<p>16 x1</p> 
<p>29 x1</p> 	<p>30 x1</p> 	<p>31 x1</p> 	<p>32 x1</p> 
<p>39 x1</p> 	<p>40 x1</p> 	<p>42 x2</p> 	<p>50 x1</p> 

STEP 1  Note the orientation of the holes.
Achten Sie auf die Ausrichtung der Löcher.

A		M6*55	8
---	--	-------	---

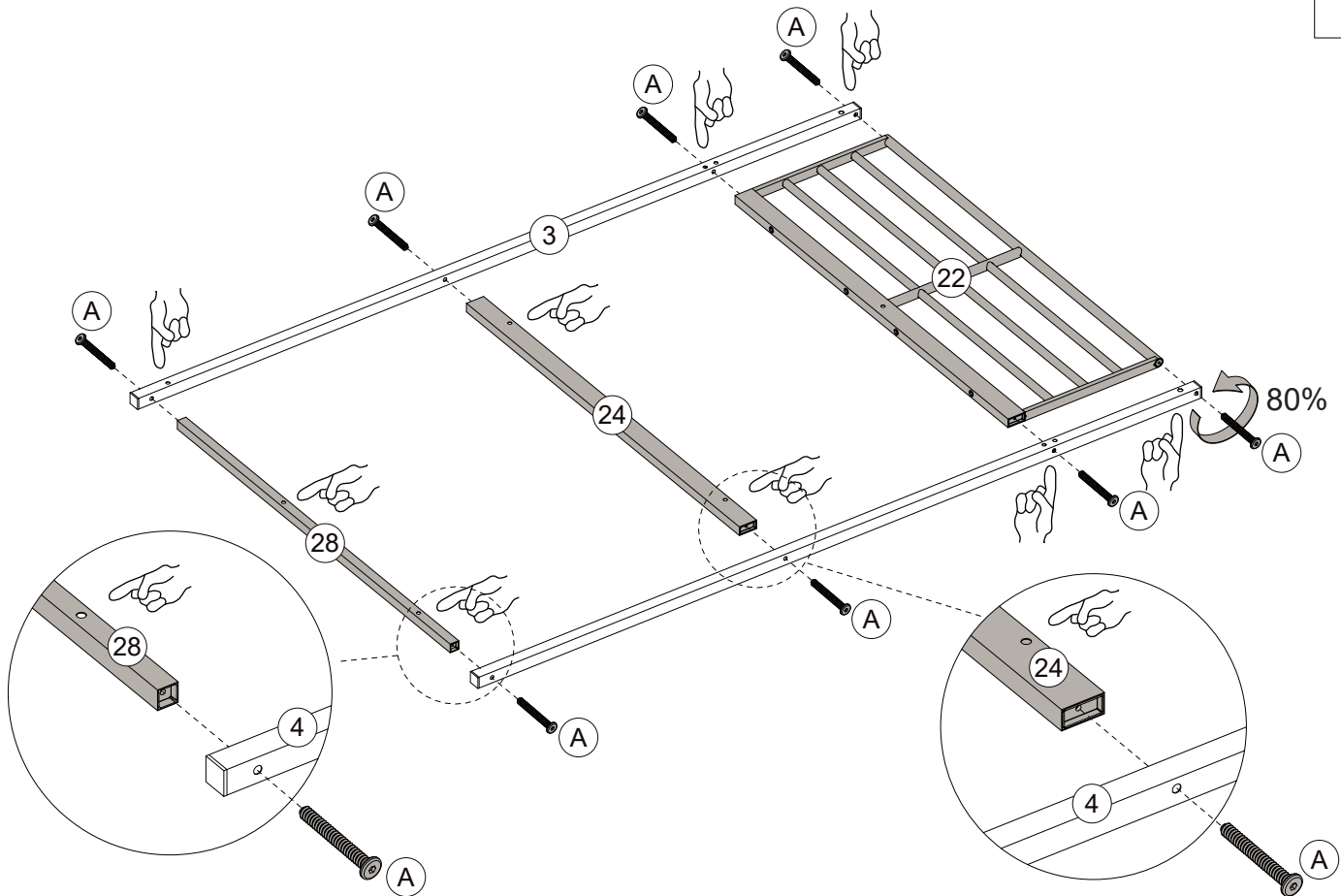

STEP 2  Note the orientation of the holes.
Achten Sie auf die Ausrichtung der Löcher.

B		M6*35	8
---	---	-------	---

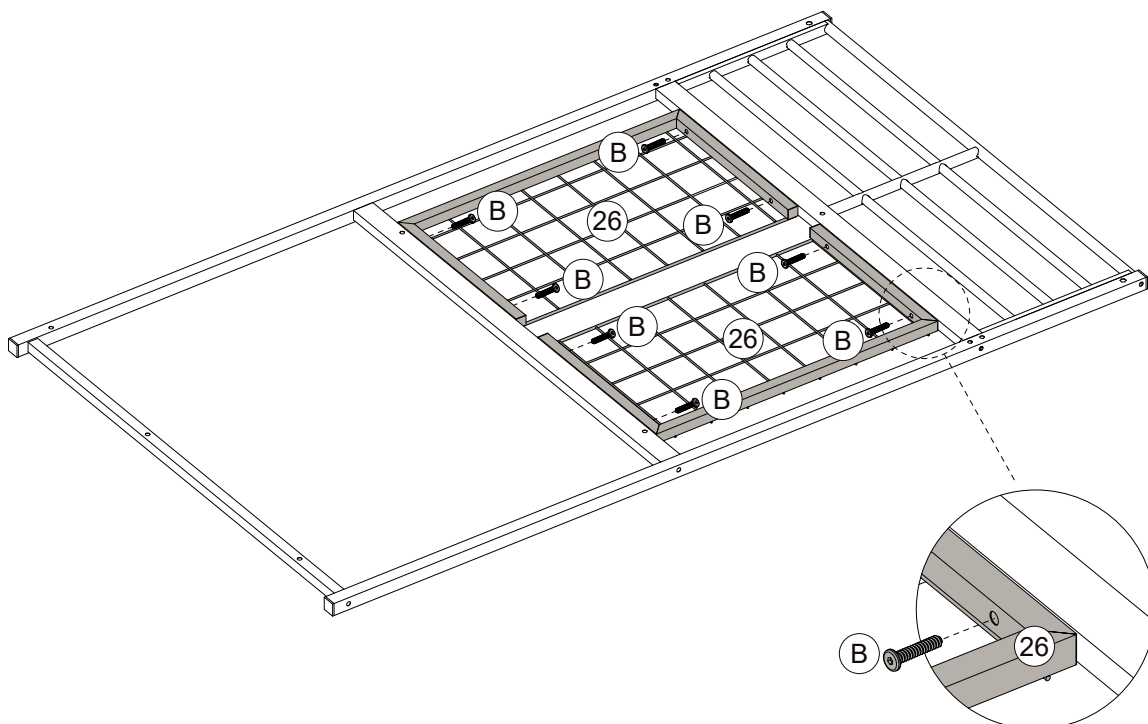

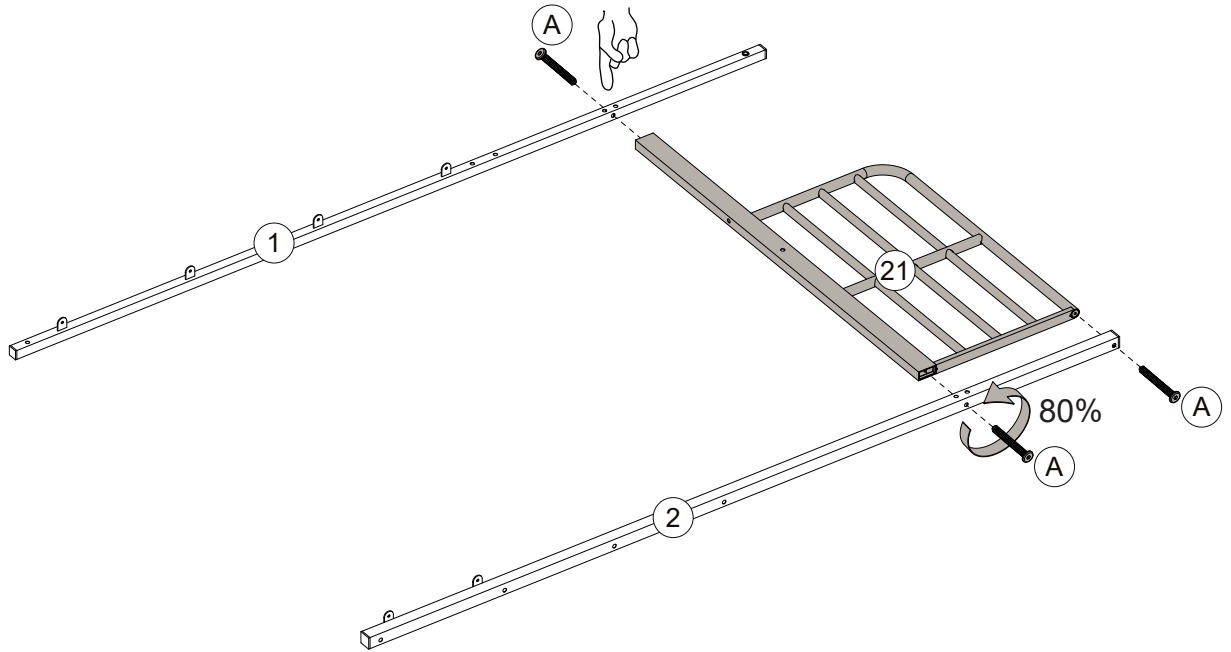

STEP 3  Note the orientation of the holes.
Achten Sie auf die Ausrichtung der Löcher.

A		M6*55	3
---	--	-------	---



STEP 4

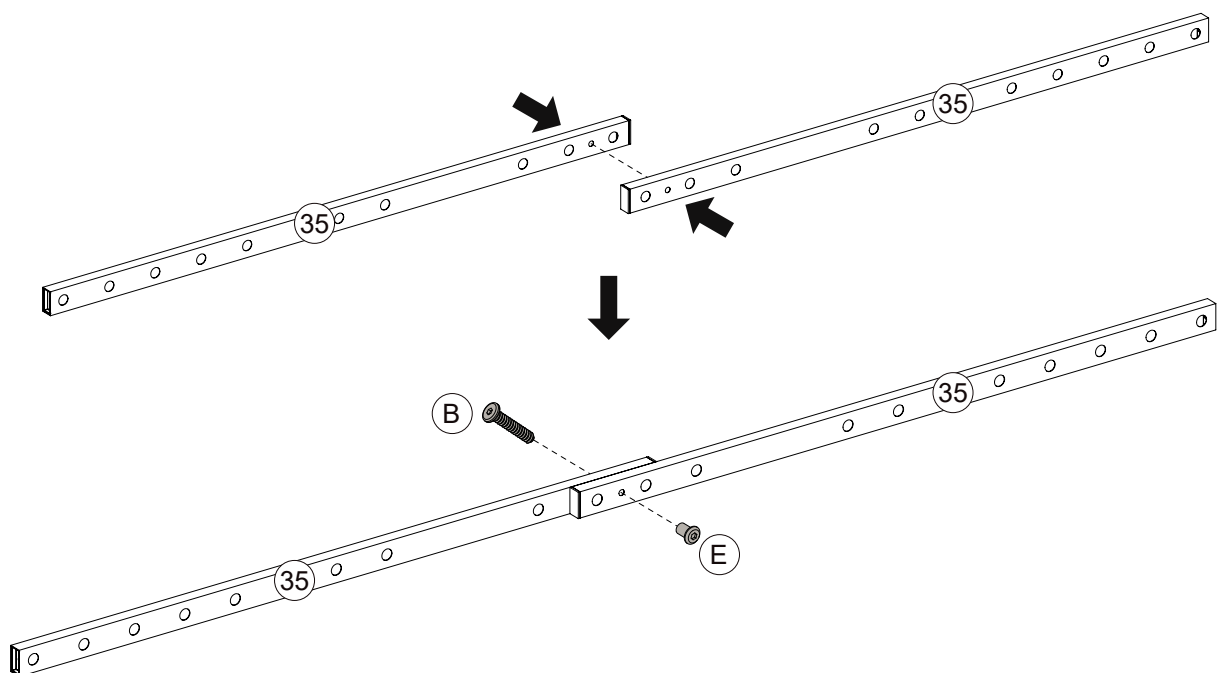

B		M6*35	1
E		M6*15	1

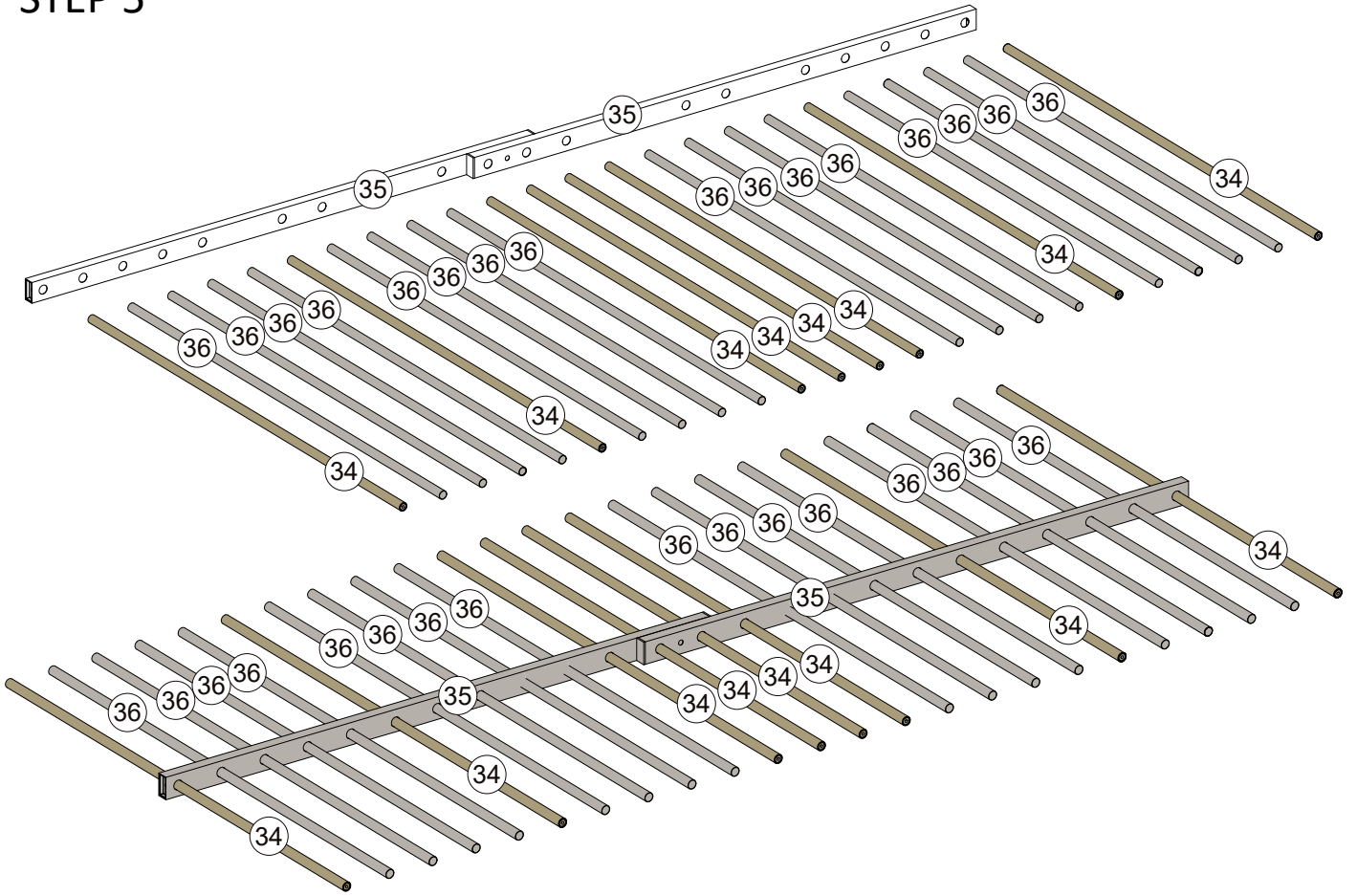

STEP 5



STEP 6

C		M6*10	1
E		M6*15	1

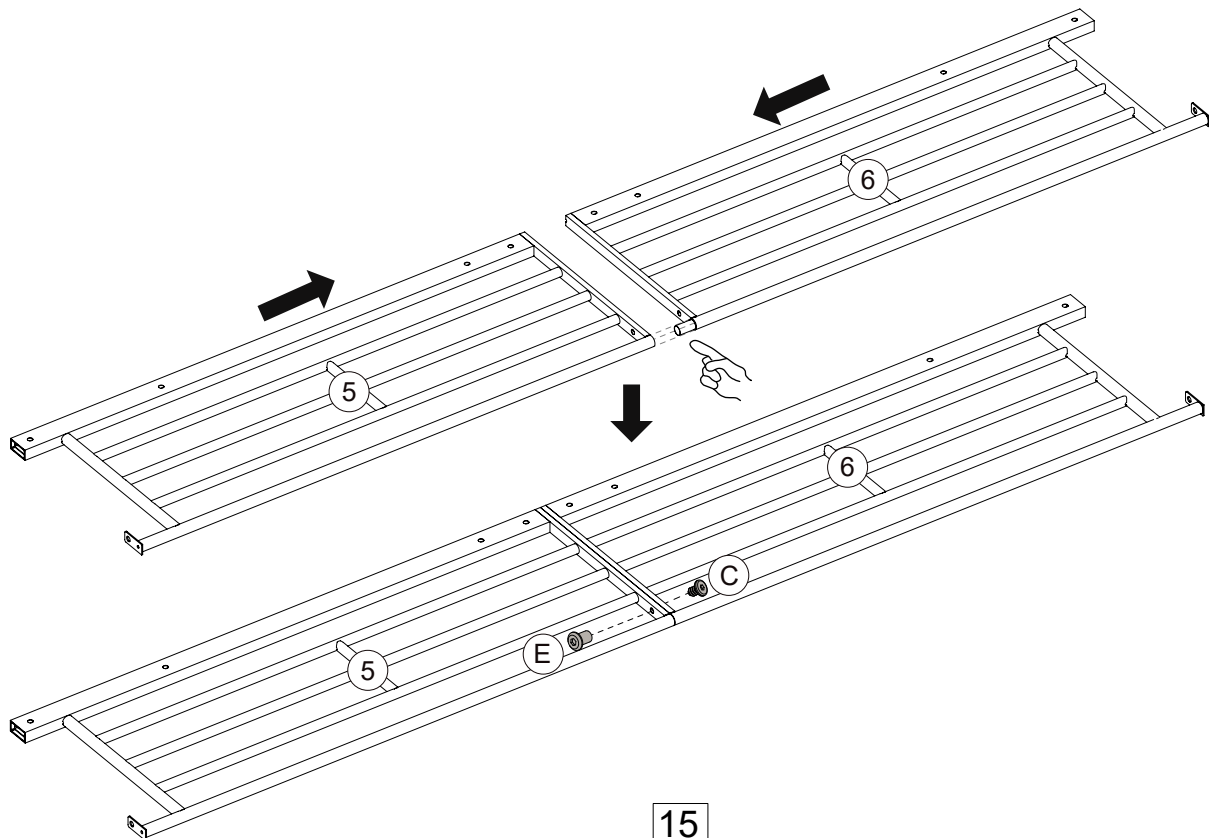

STEP 7

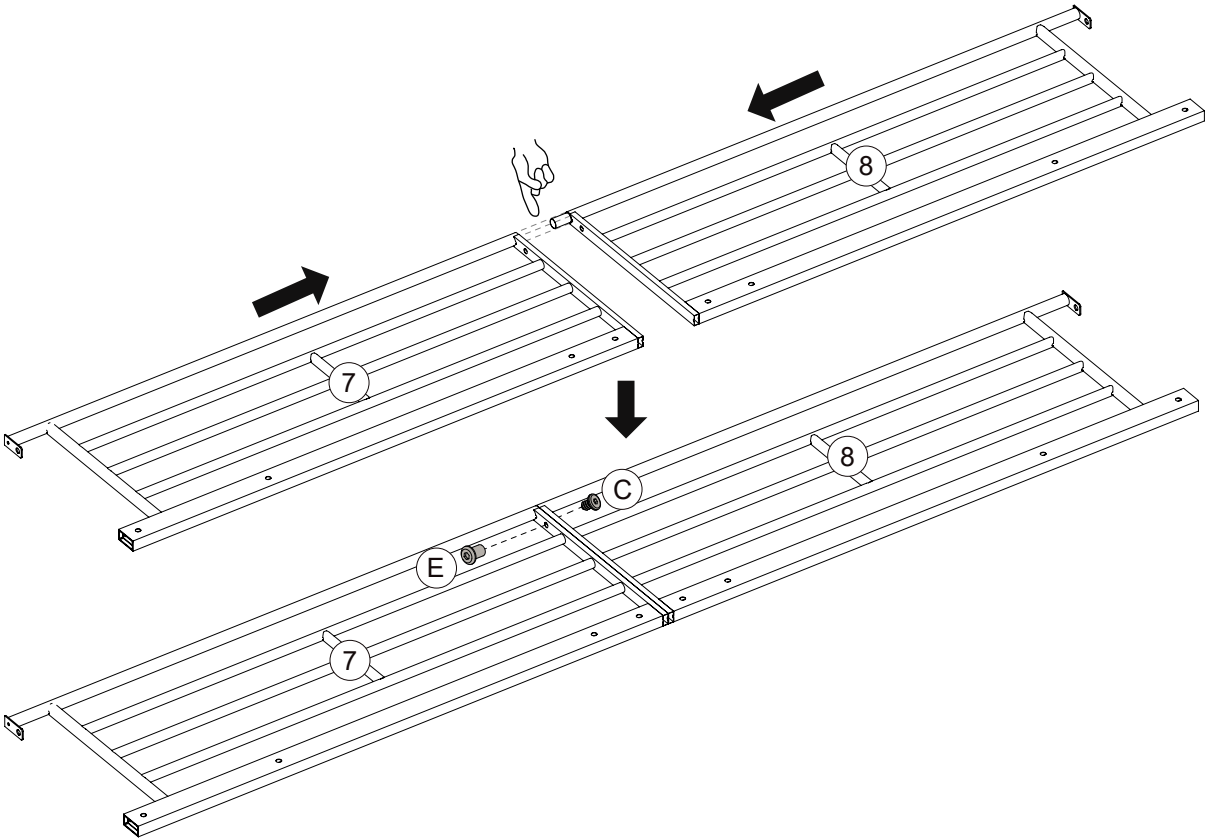

C		M6*10	1
E		M6*15	1

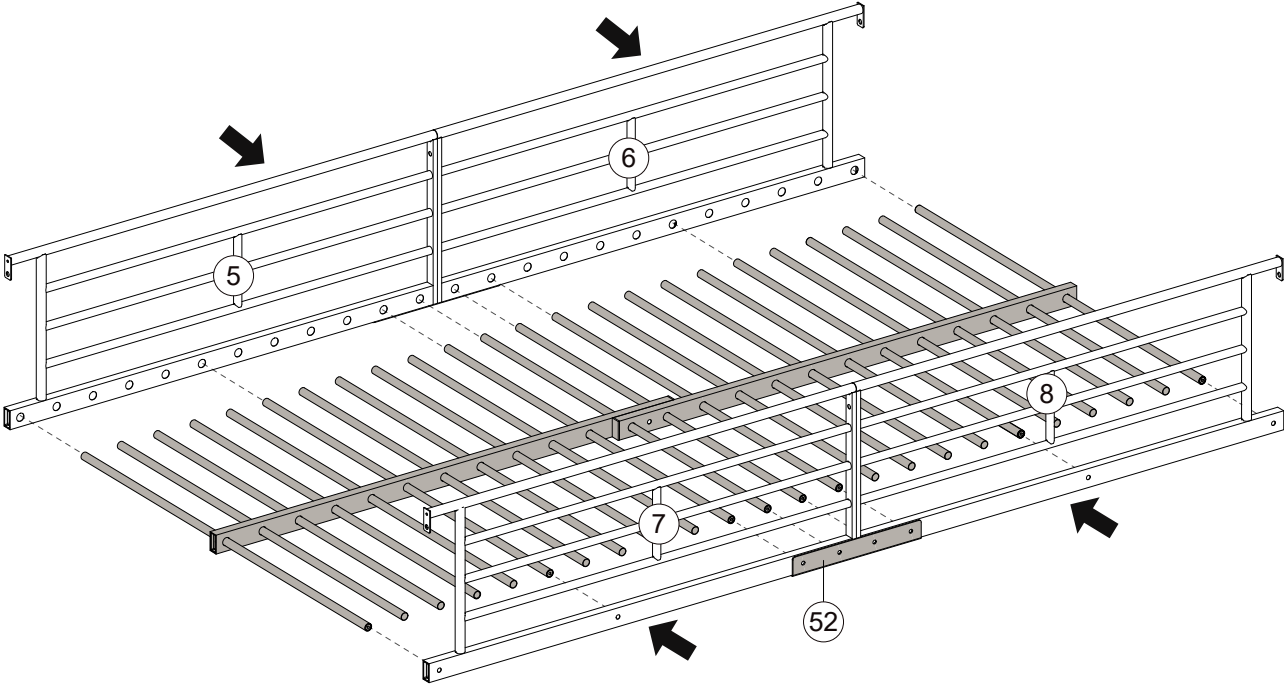

STEP 8



STEP 9



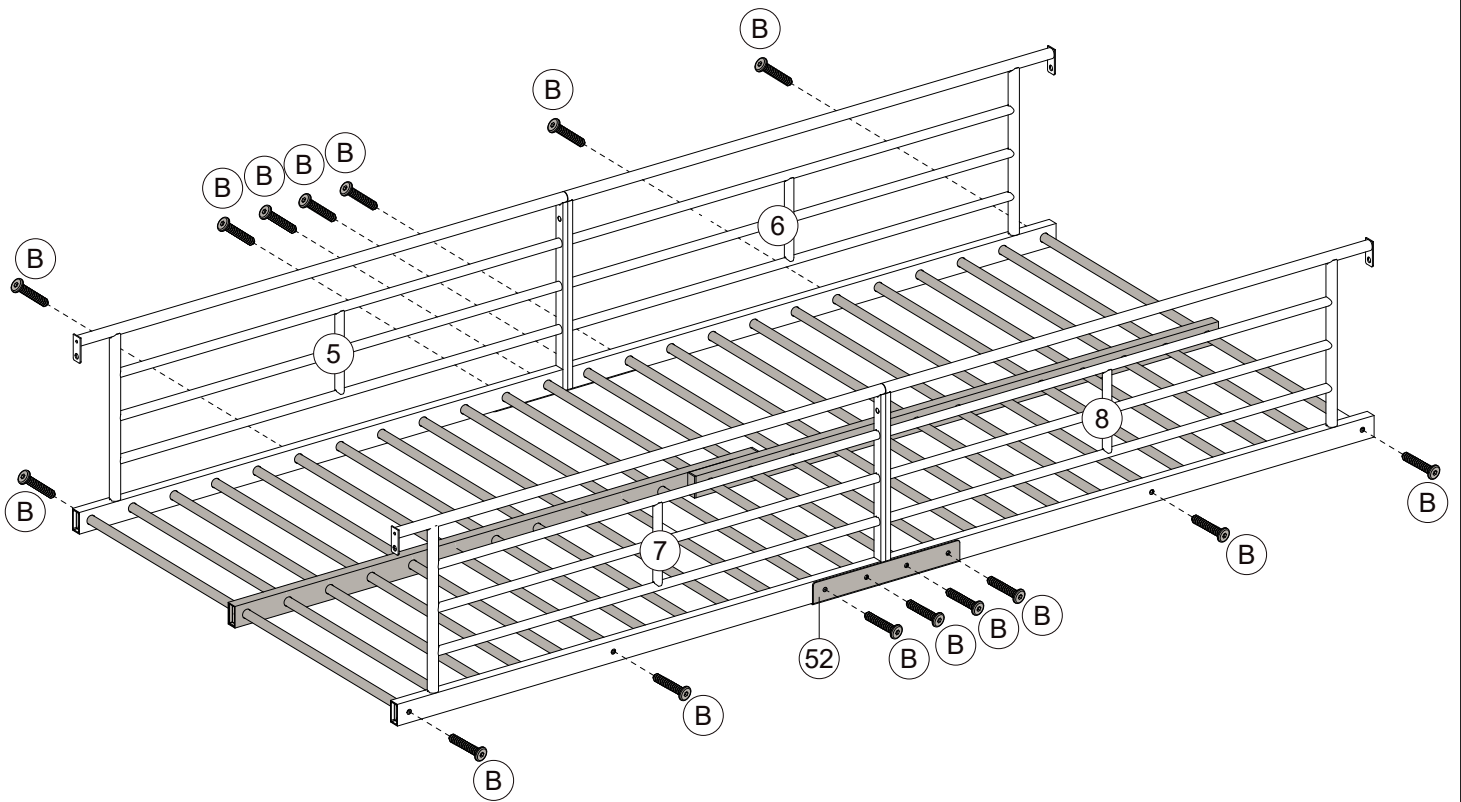

B		M6*35	16	
				



STEP 10





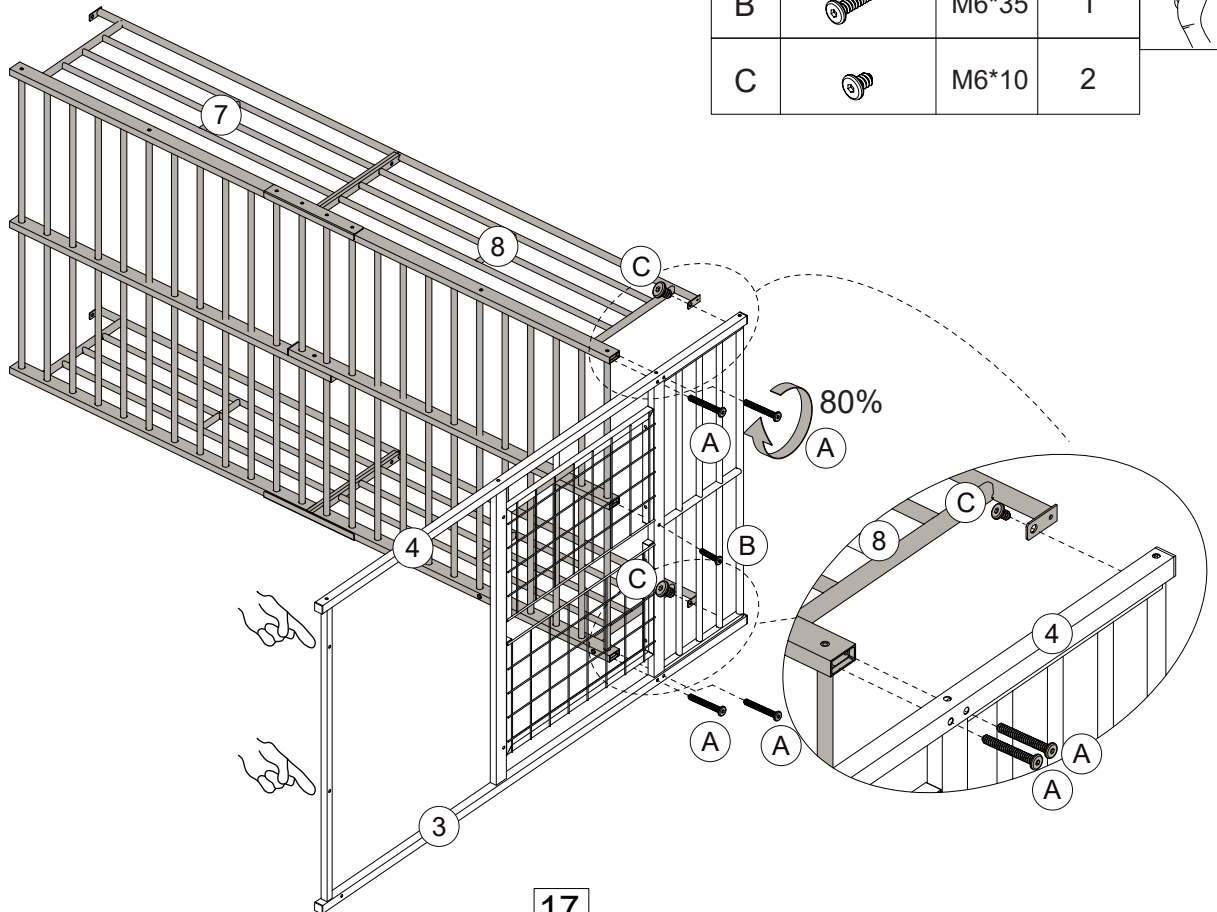

Note the orientation of the holes.
Achten Sie auf die Ausrichtung der Löcher.

A		M6*55	4	
B		M6*35	1	
C		M6*10	2	



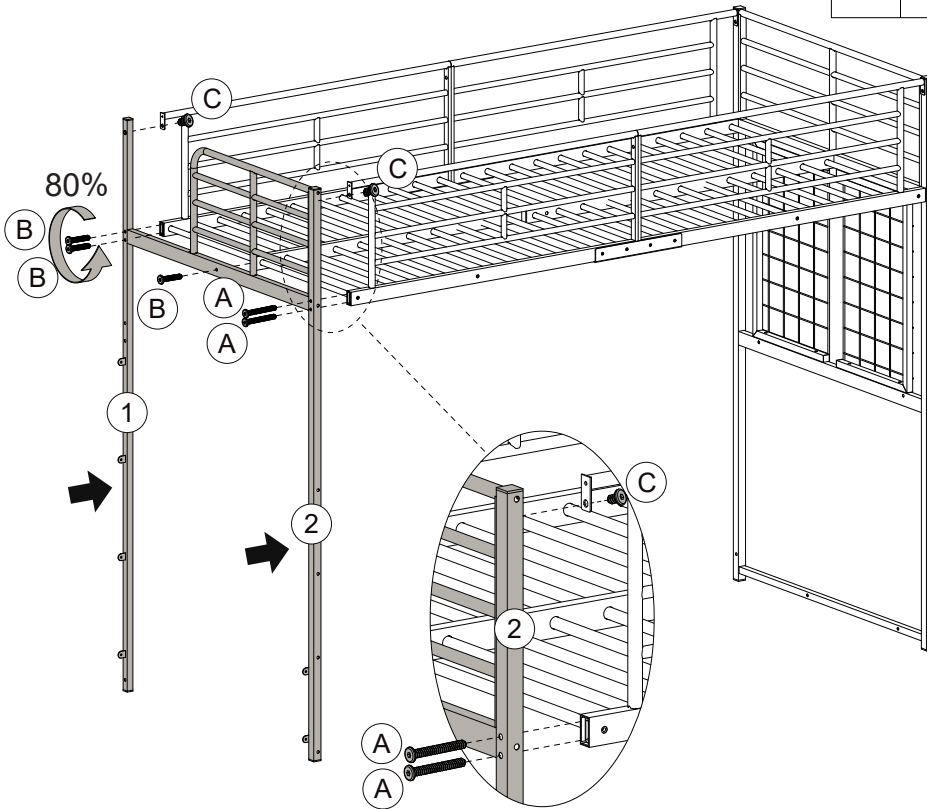

STEP 11

A		M6*55	2	 
B		M6*35	3	
C		M6*10	2	



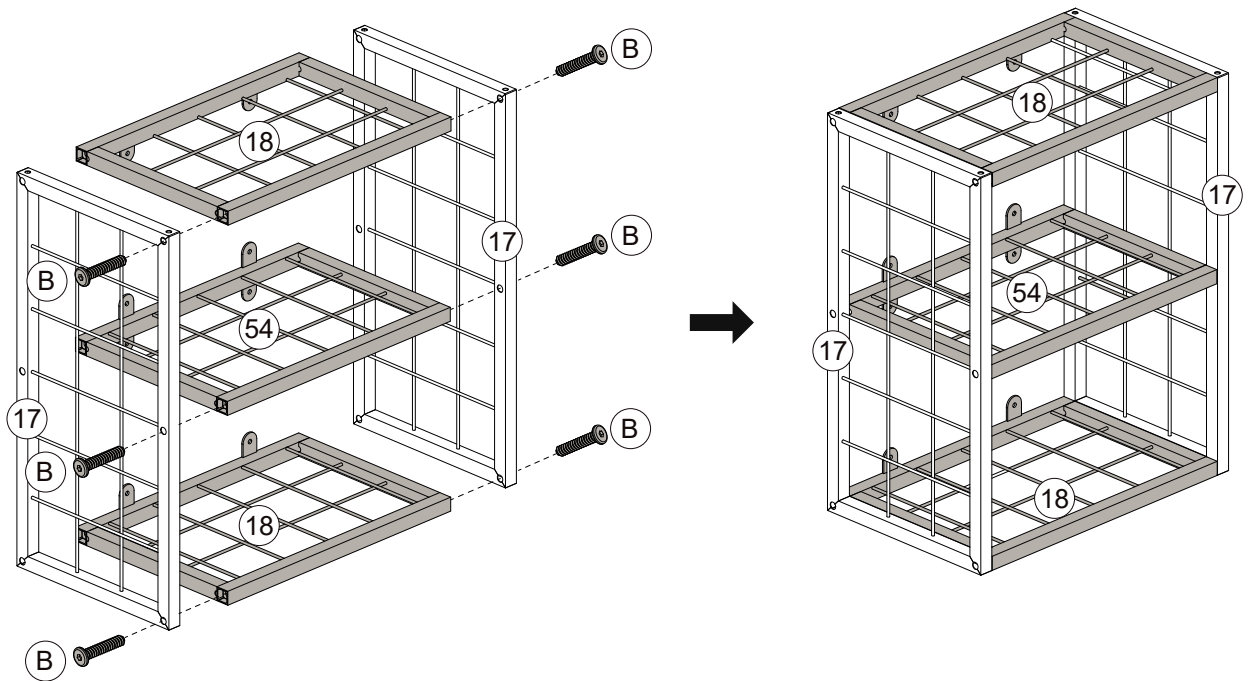

STEP 12

B		M6*35	6	 
---	---	-------	---	--





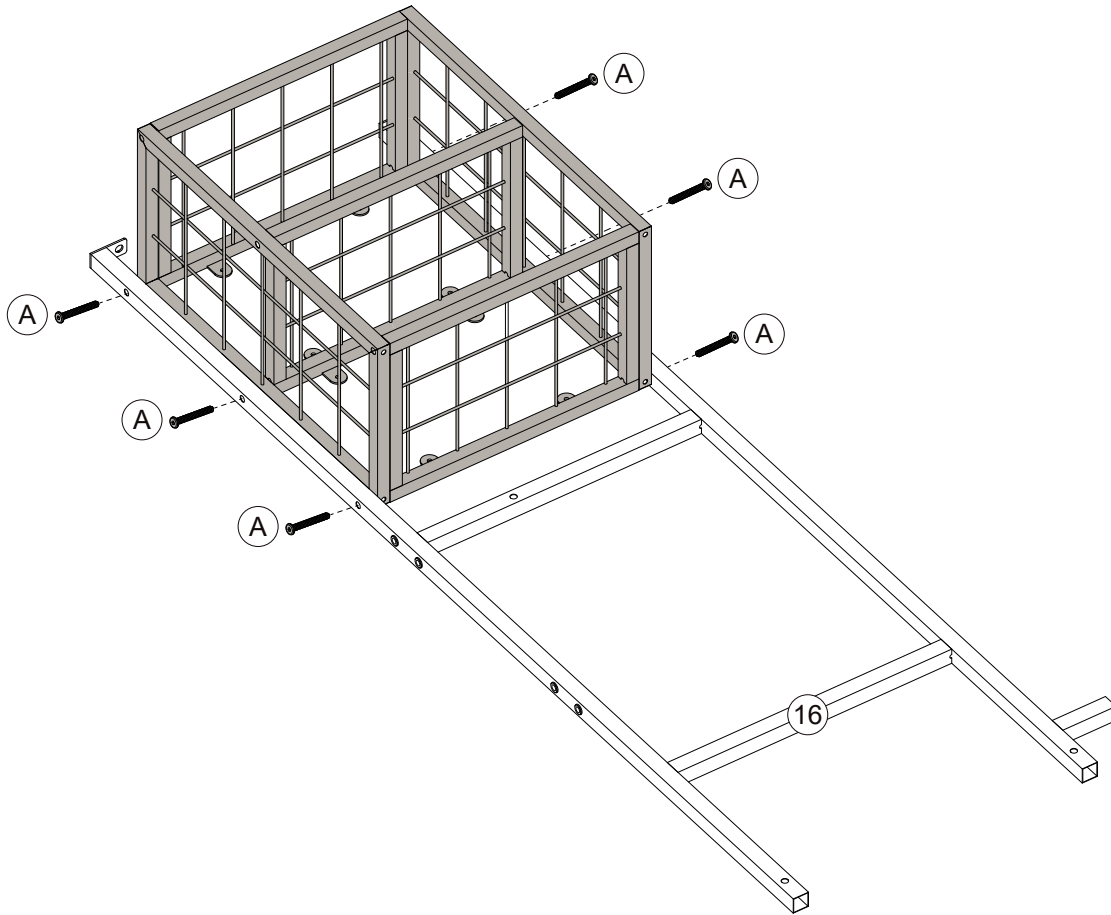

STEP 13

A		M6*55	6	 
---	--	-------	---	---



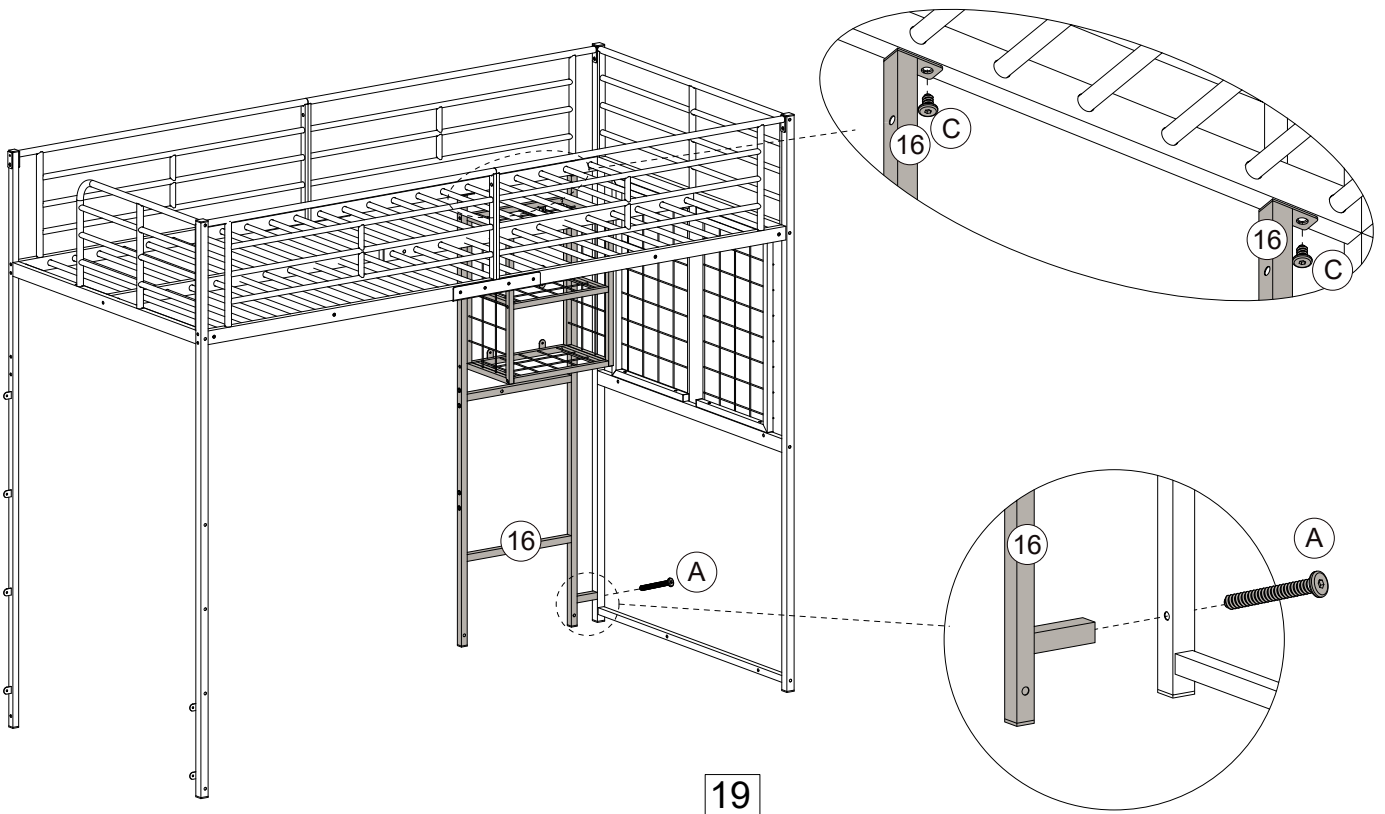

STEP 14

A		M6*55	1	 
C		M6*10	2	





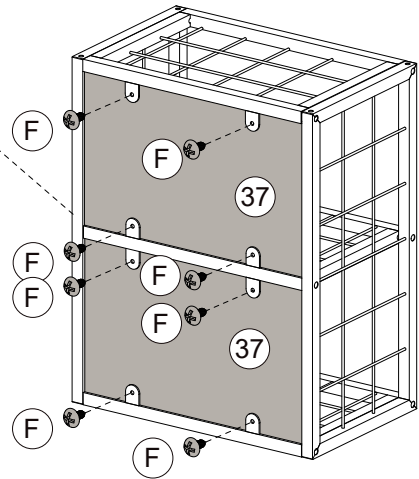
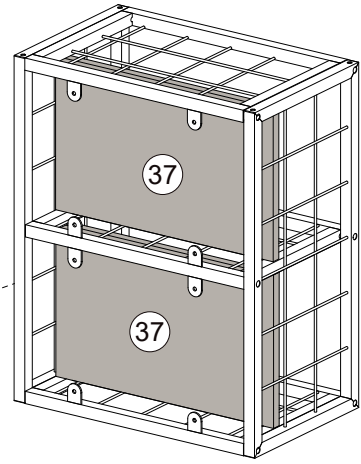
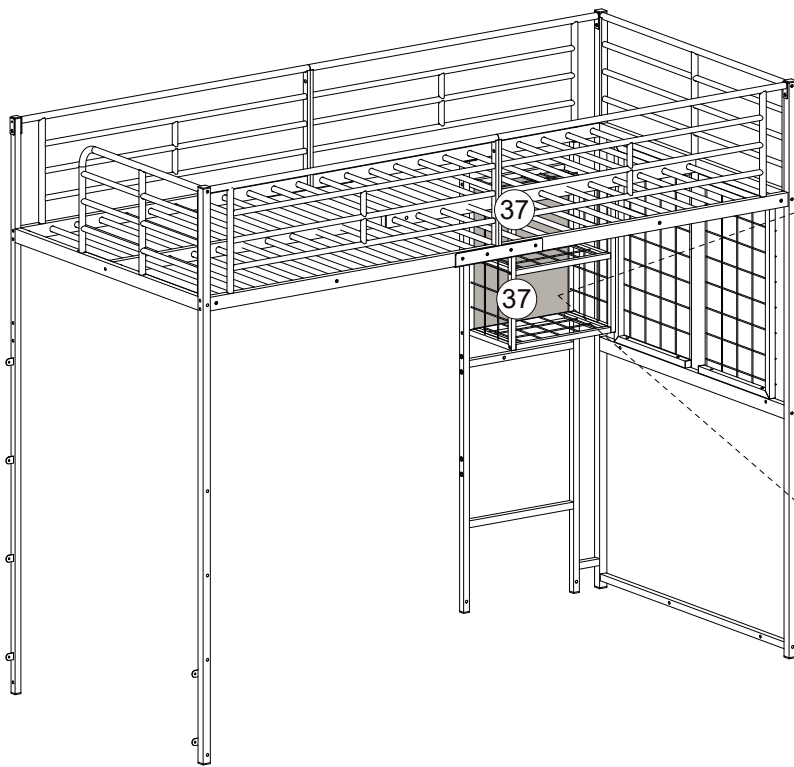

STEP 15

F		3.5*10	8	
---	--	--------	---	--





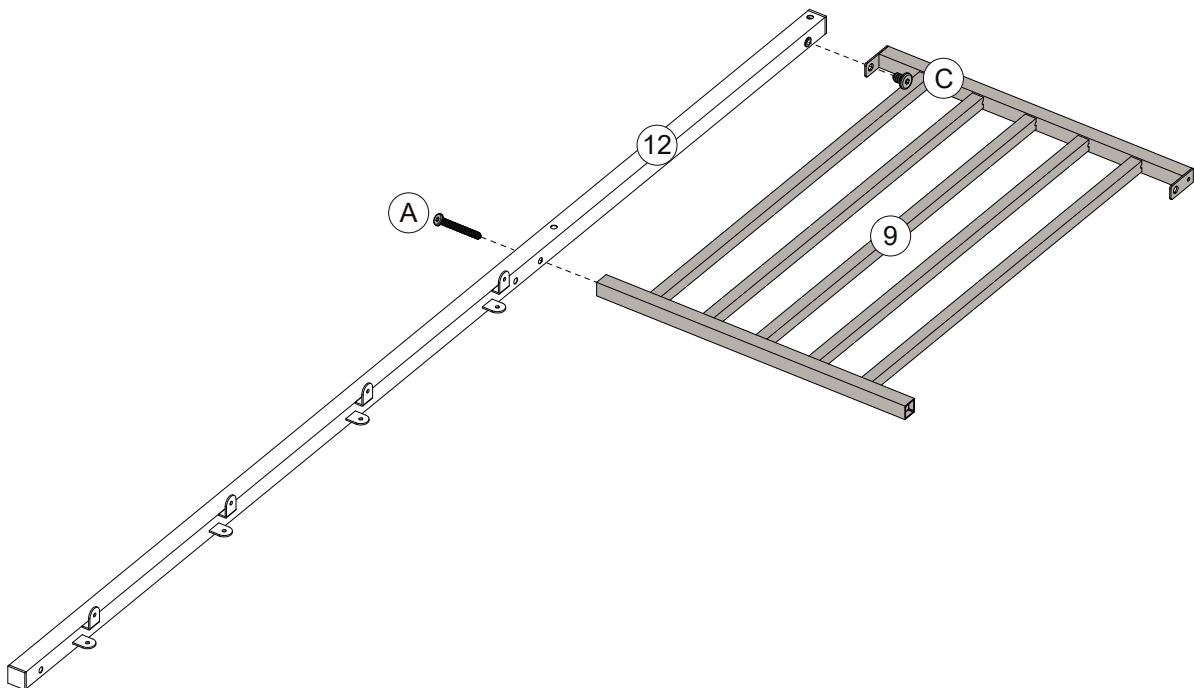

STEP 16 Note the orientation of the holes. Achten Sie auf die Ausrichtung der Löcher.

A		M6*55	1	
C		M6*10	1	



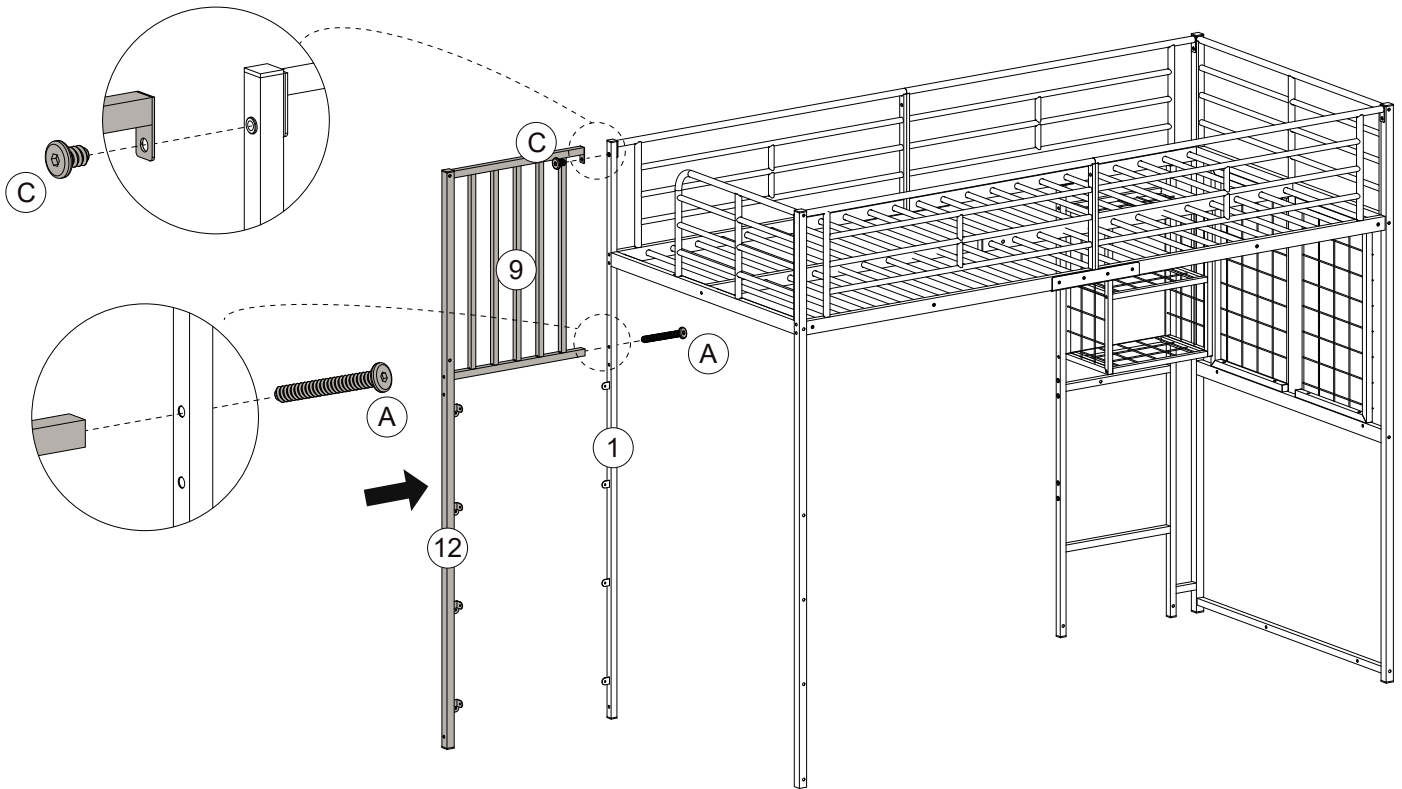

STEP 17  Note the orientation of the holes.
Achten Sie auf die Ausrichtung der Löcher.

A		M6*55	1	 
C		M6*10	1	



STEP 18  Note the orientation of the holes.
Achten Sie auf die Ausrichtung der Löcher.

A		M6*55	1	 
---	---	-------	---	--

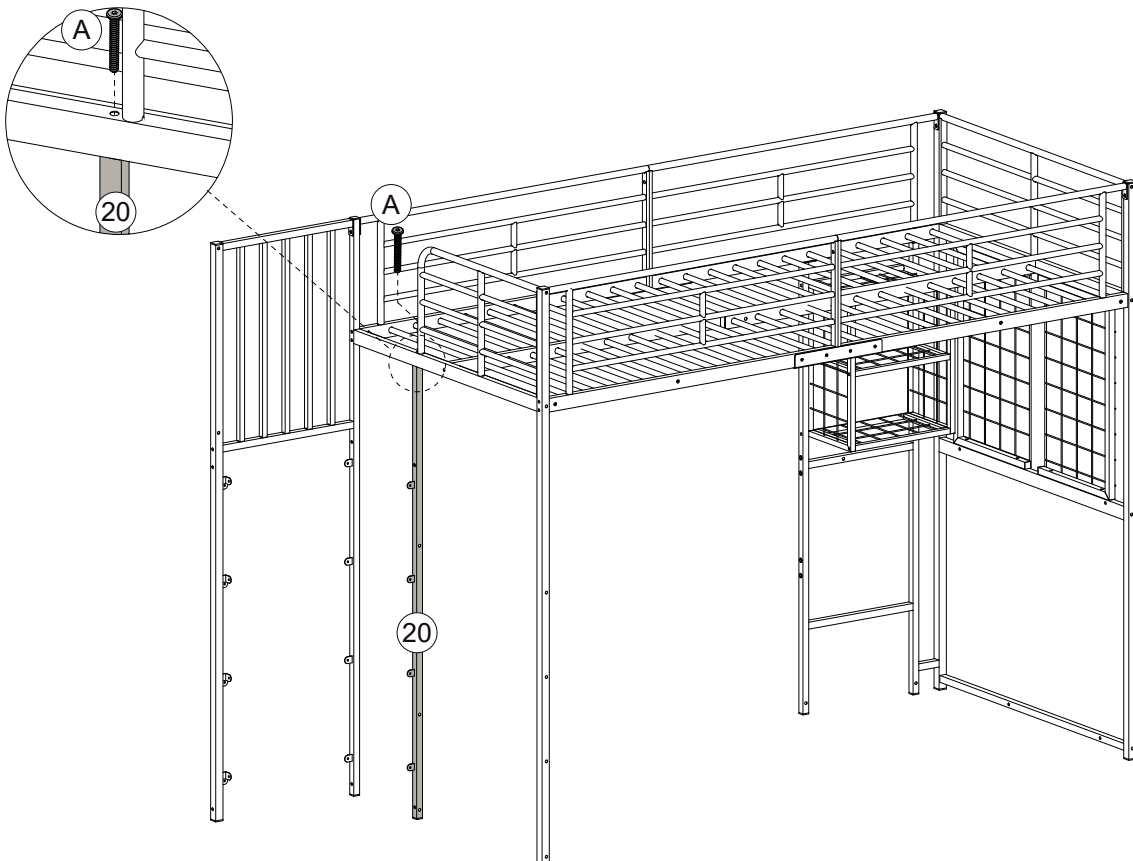

STEP 19

A		M6*55	1
---	--	-------	---

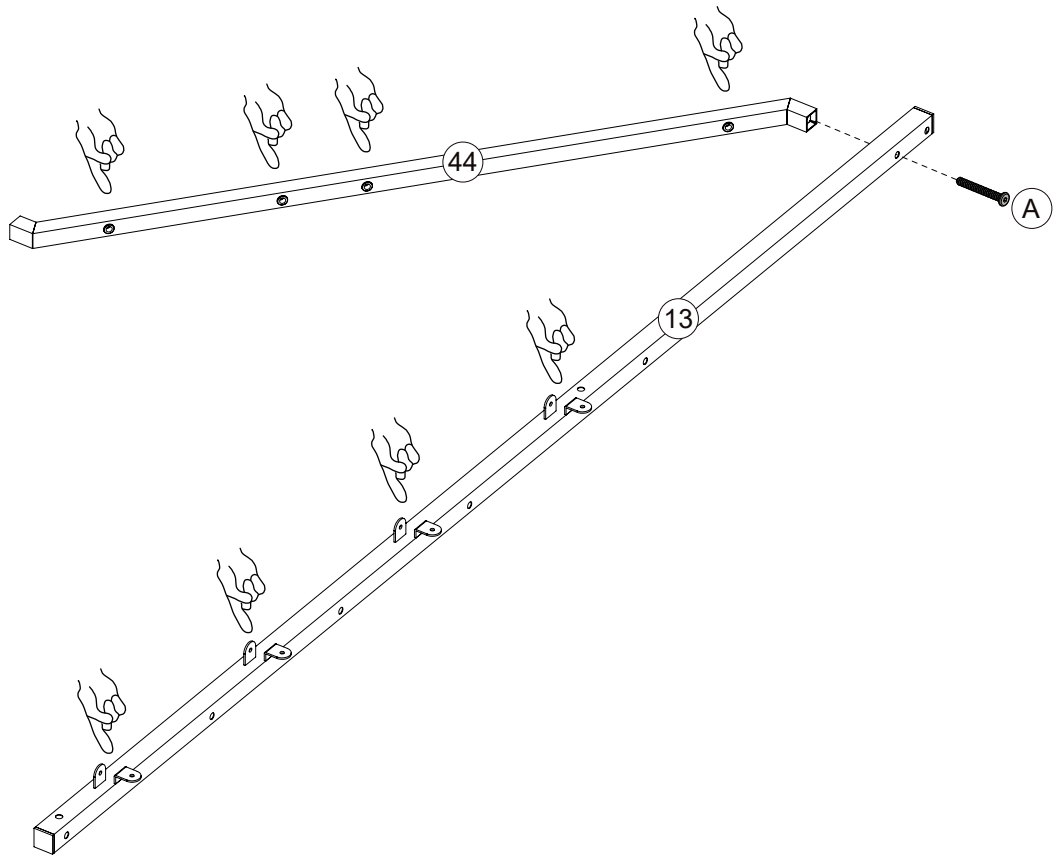

STEP 20

A		M6*55	1
---	---	-------	---

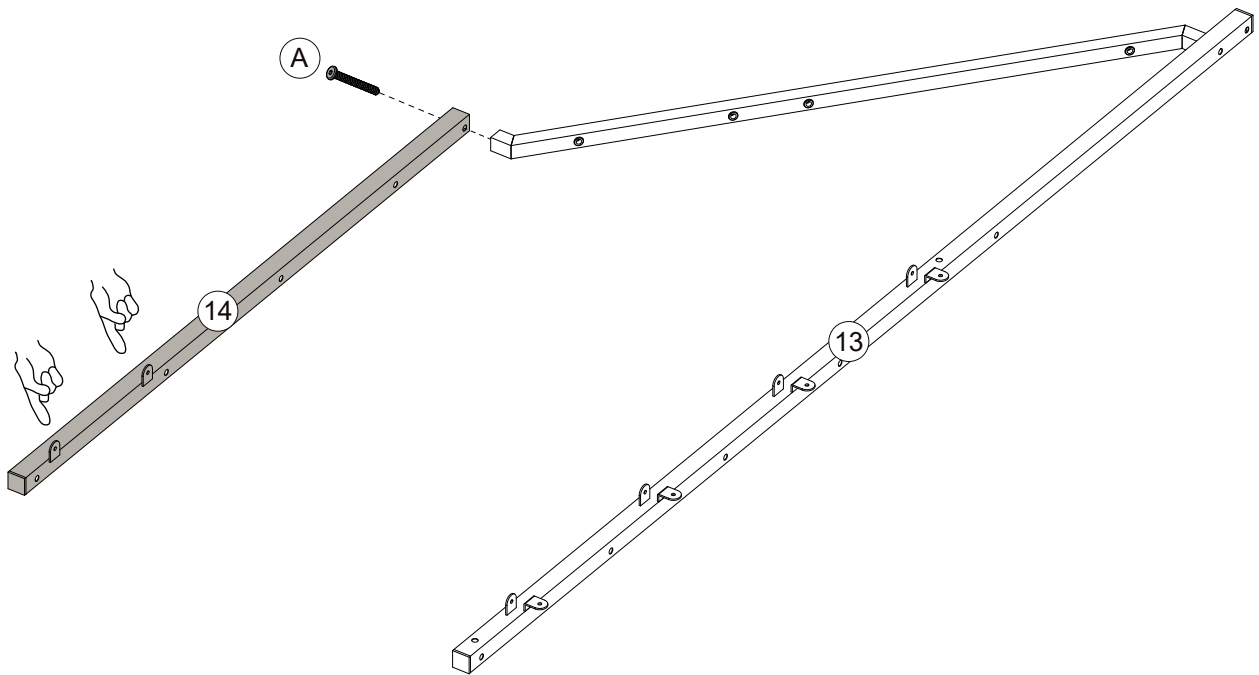

STEP 21

A		M6*55	2
---	--	-------	---



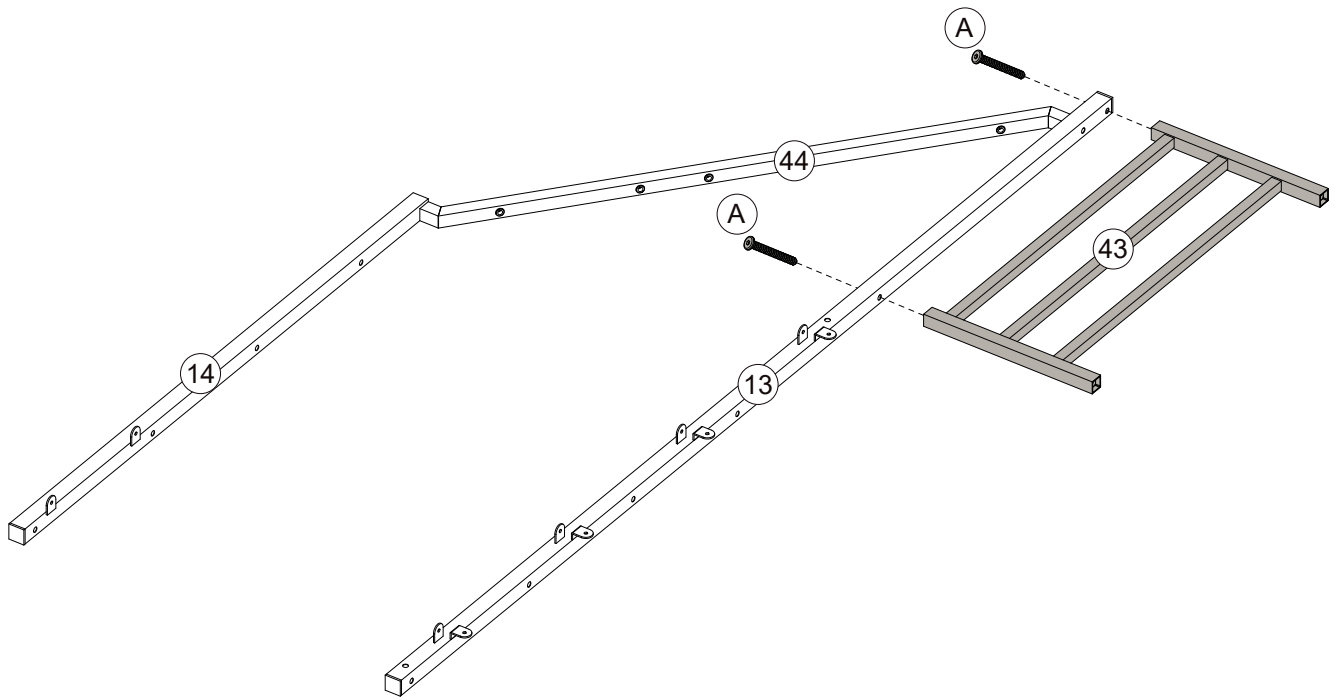

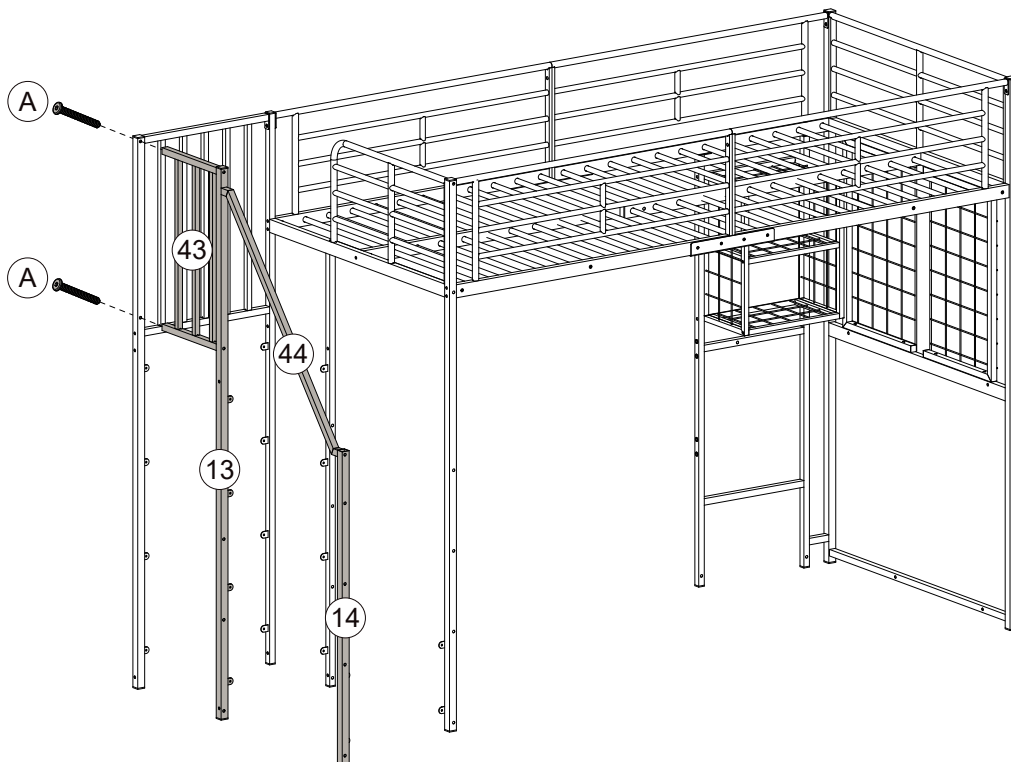

STEP 22

A		M6*55	2
---	---	-------	---





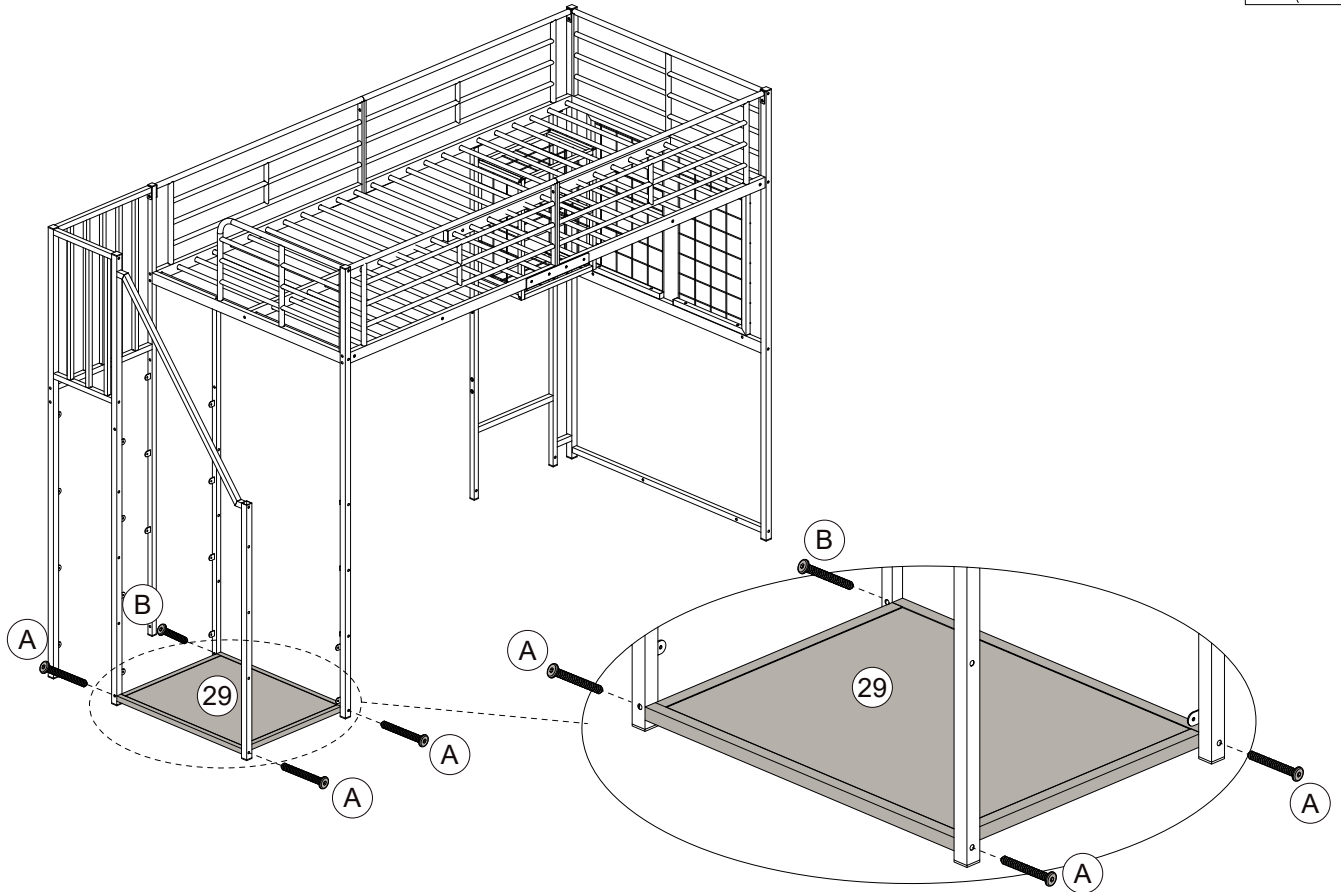

STEP 23

A		M6*55	3	 
B		M6*35	1	





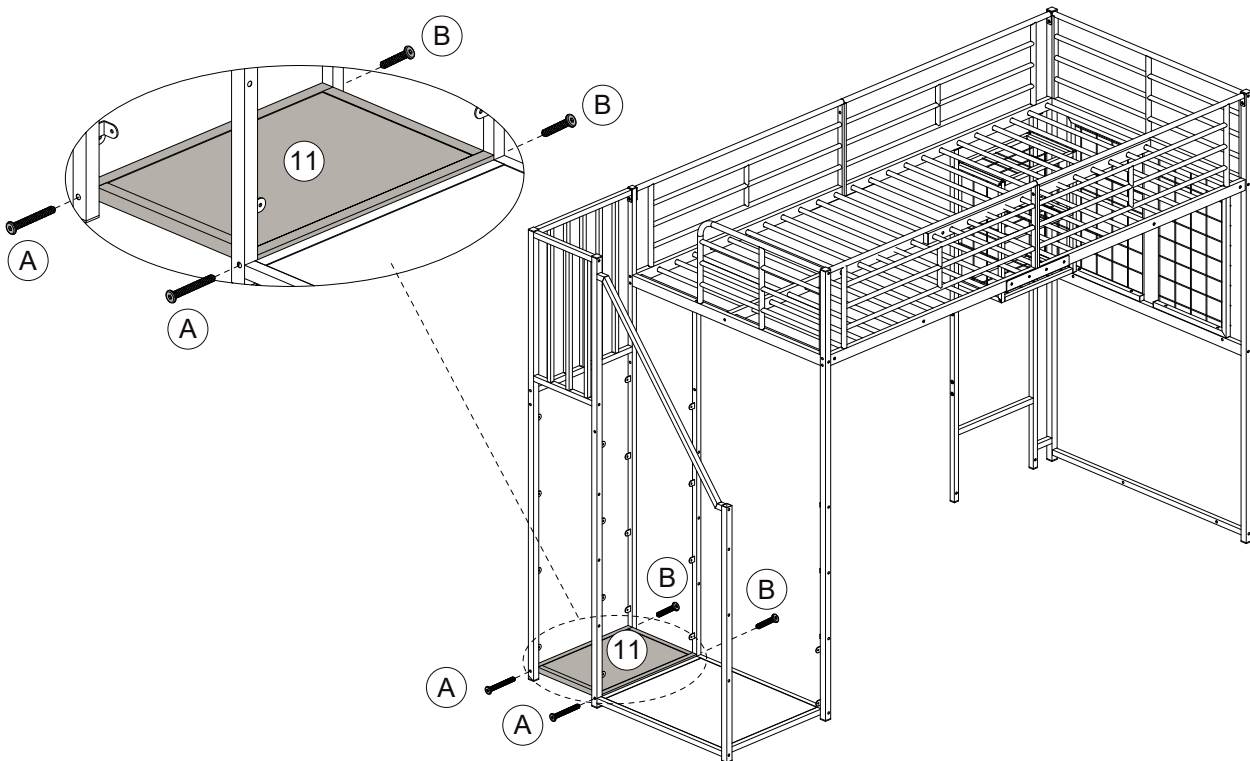

STEP 24

A		M6*55	2	 
B		M6*35	2	



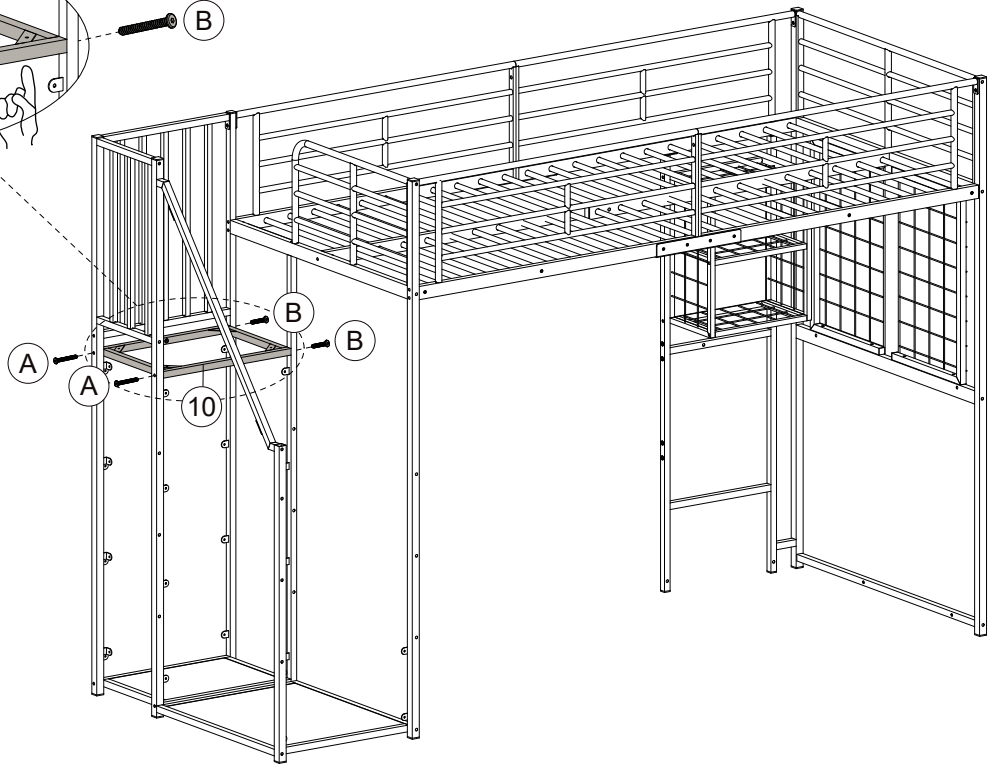
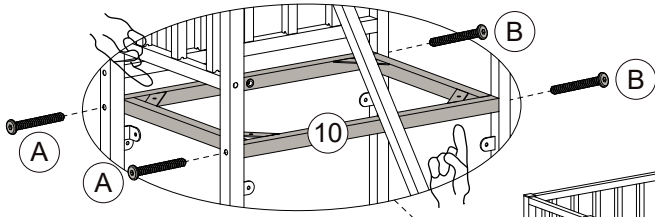

STEP 25

A		M6*55	2	 
B		M6*35	2	



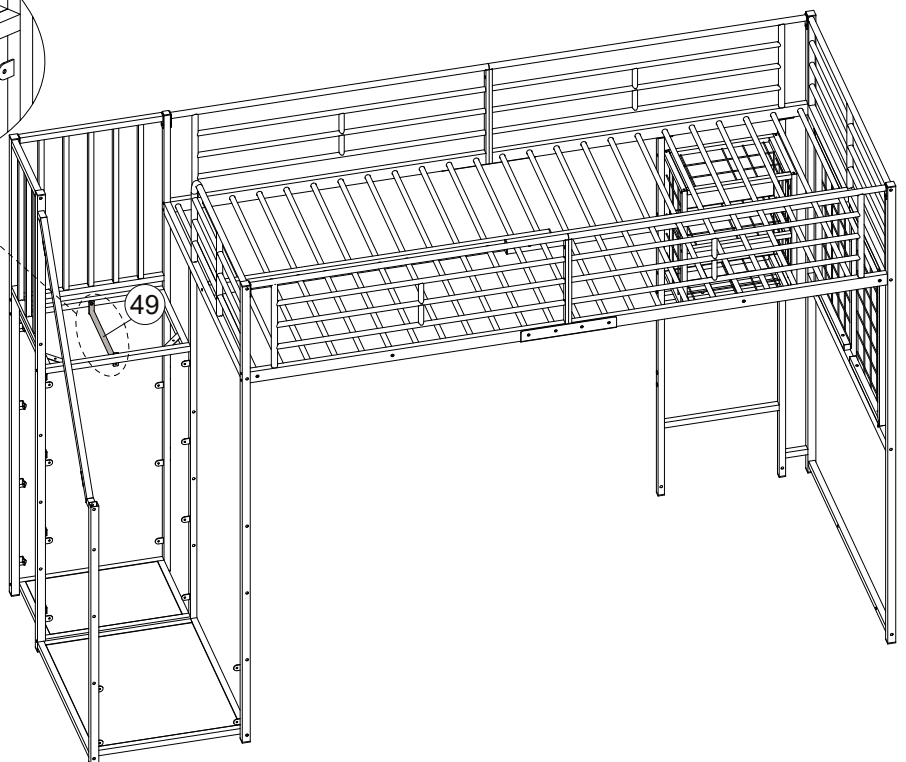
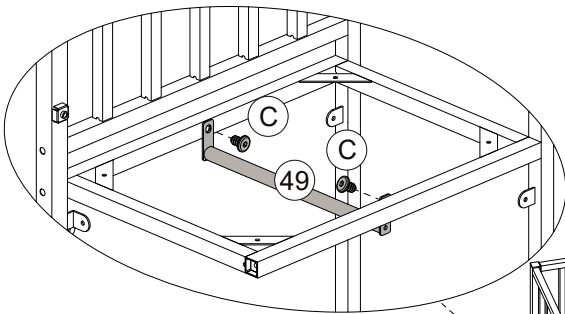

STEP 26

C		M6*10	2	 
---	---	-------	---	--





STEP 27

F		3.5*10	4	
---	--	--------	---	--

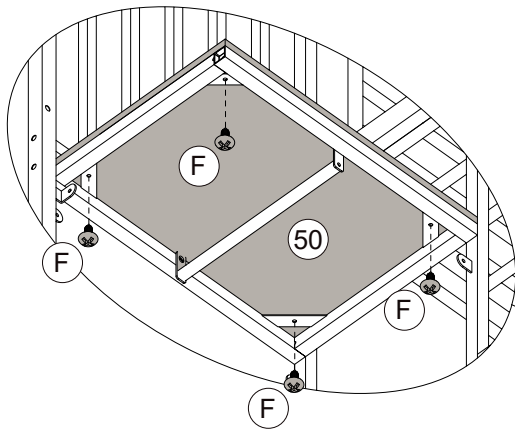





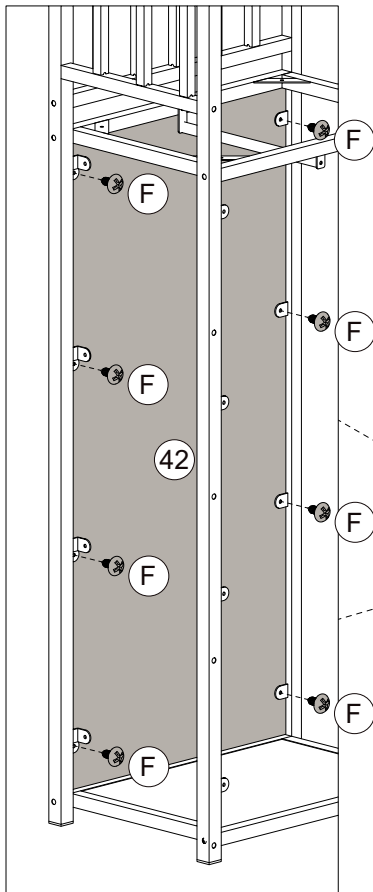

STEP 28

F		3.5*10	8	
---	---	--------	---	---







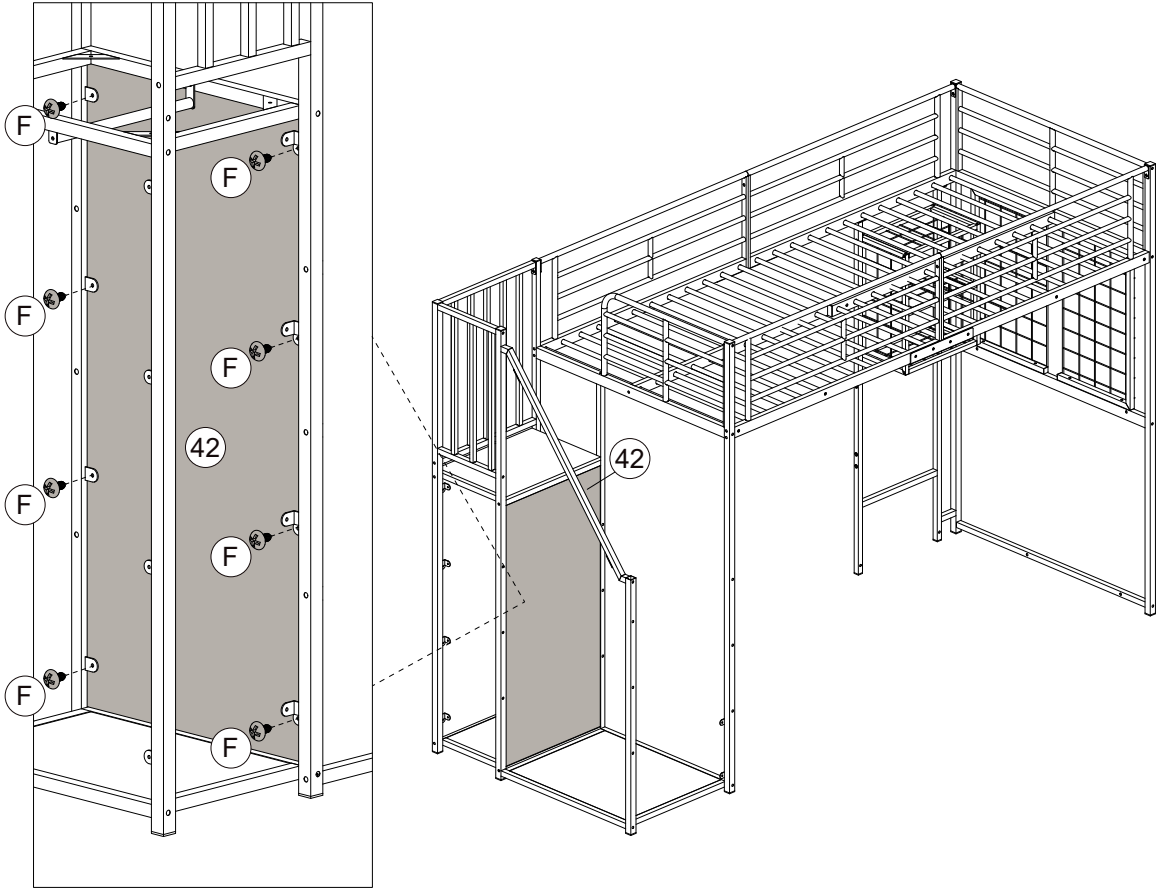

STEP 29

F		3.5*10	8	
				





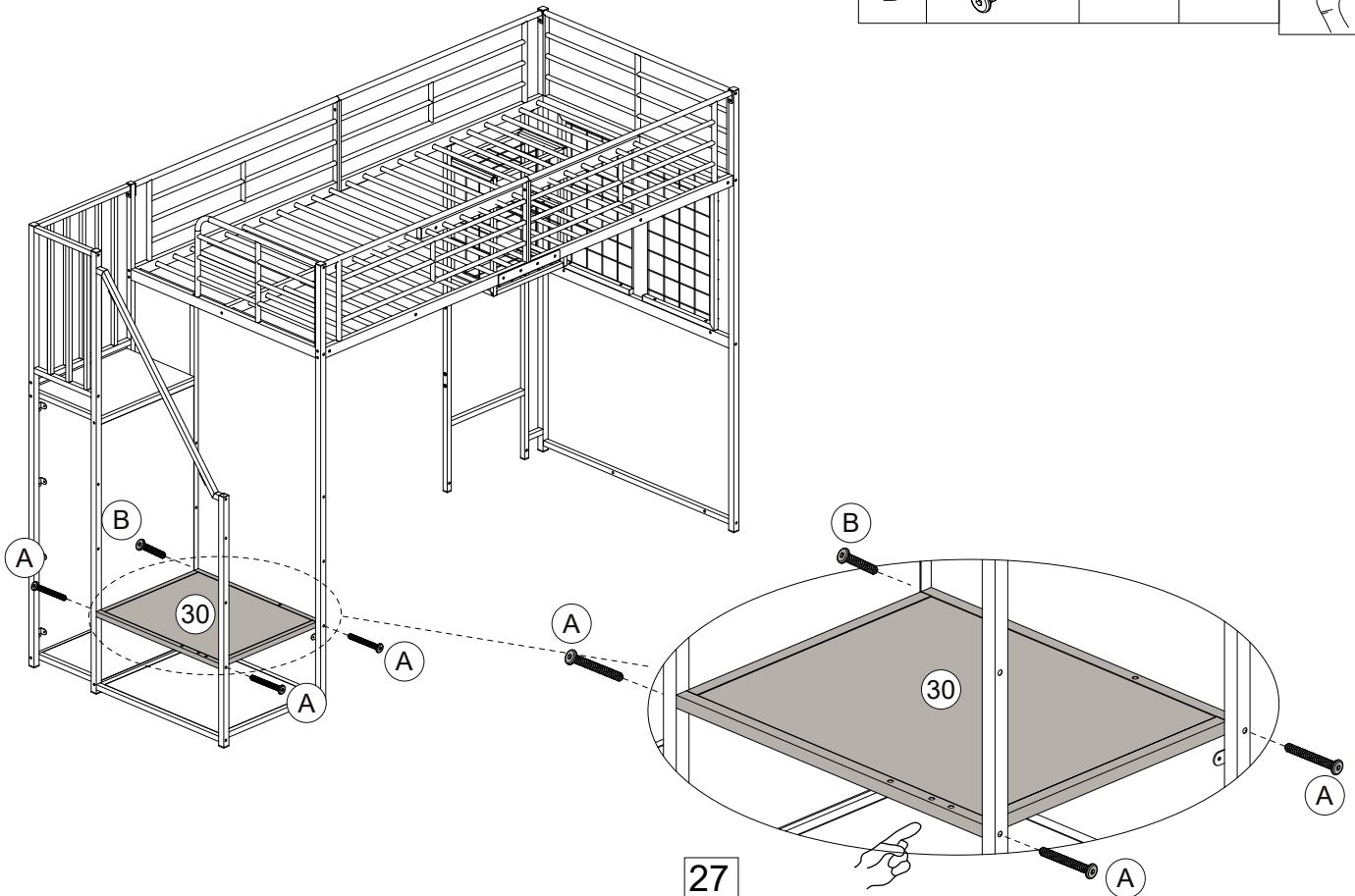

STEP 30

A		M6*55	3	
B		M6*35	1	



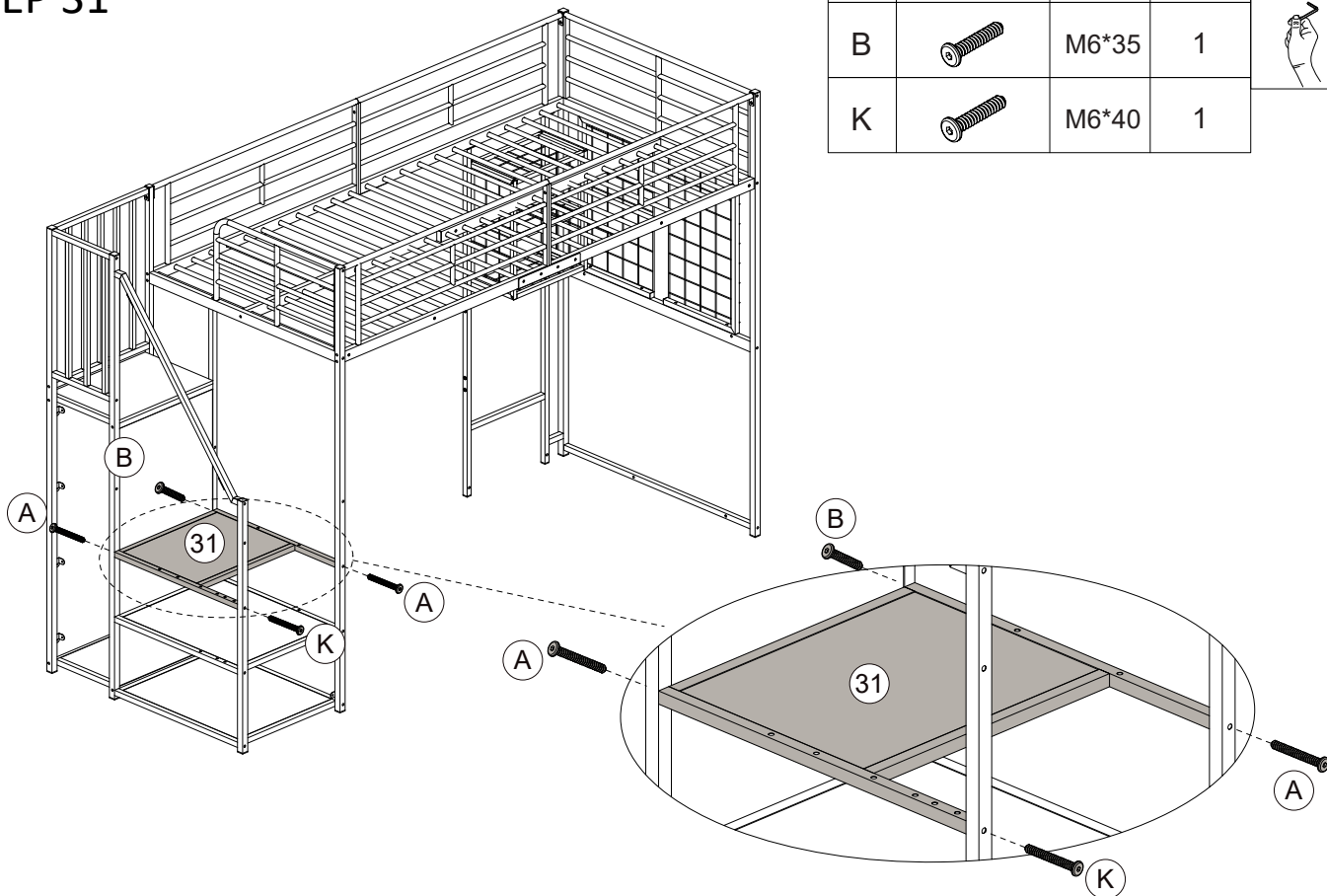

STEP 31

A		M6*55	2	 
B		M6*35	1	
K		M6*40	1	





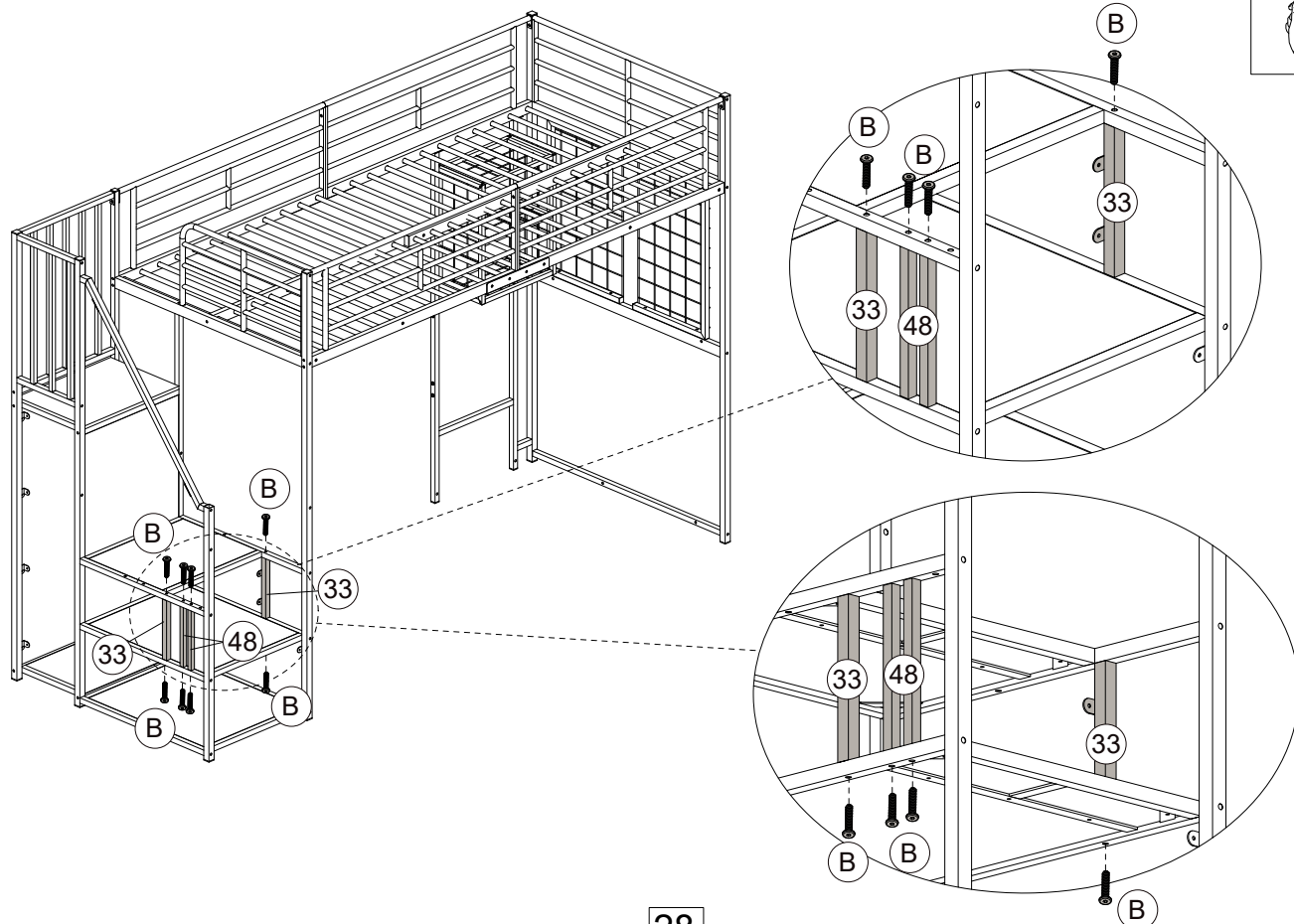

STEP 32

B		M6*35	8	 
---	---	-------	---	--





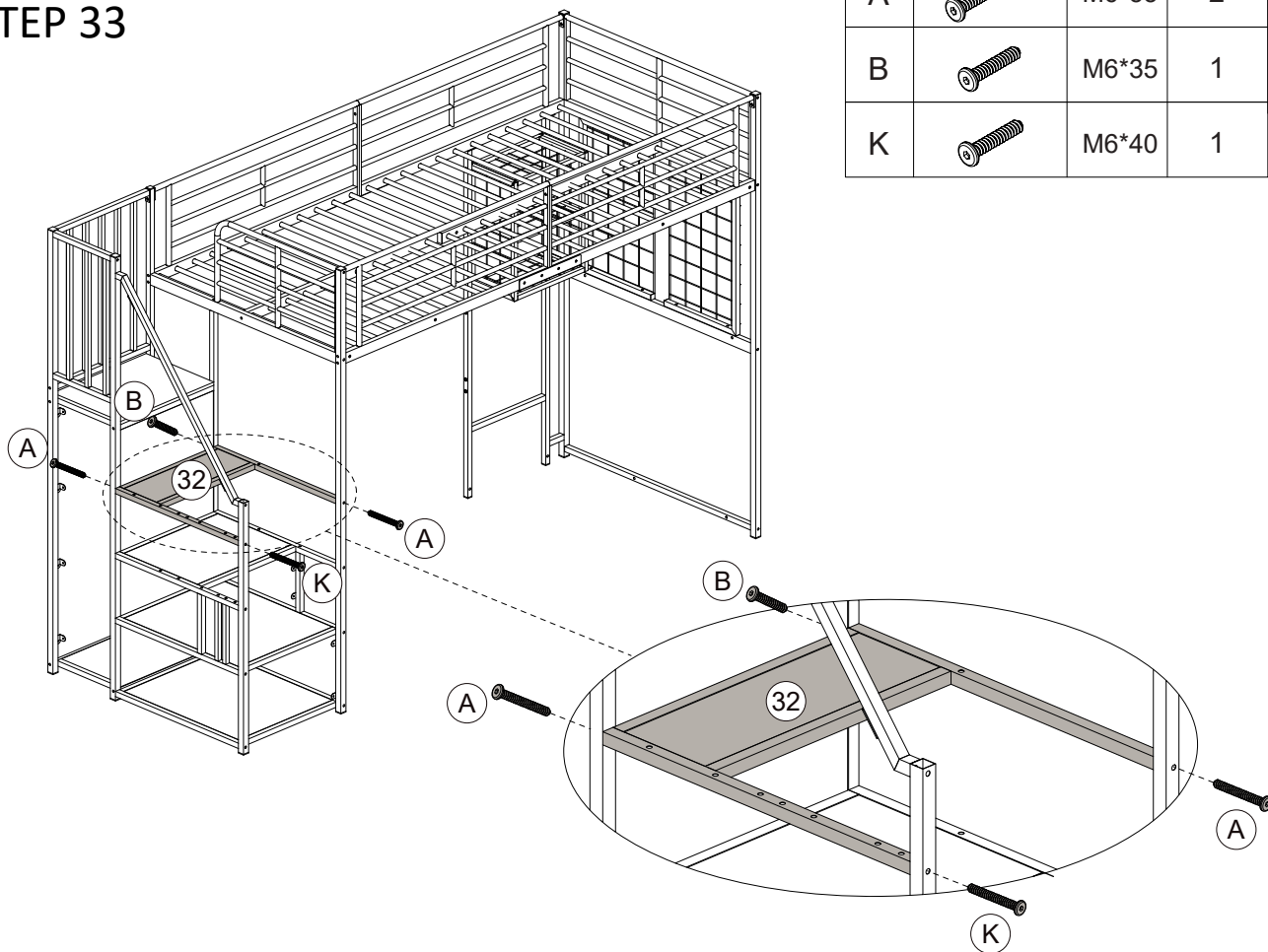

STEP 33

A		M6*55	2	 
B		M6*35	1	
K		M6*40	1	





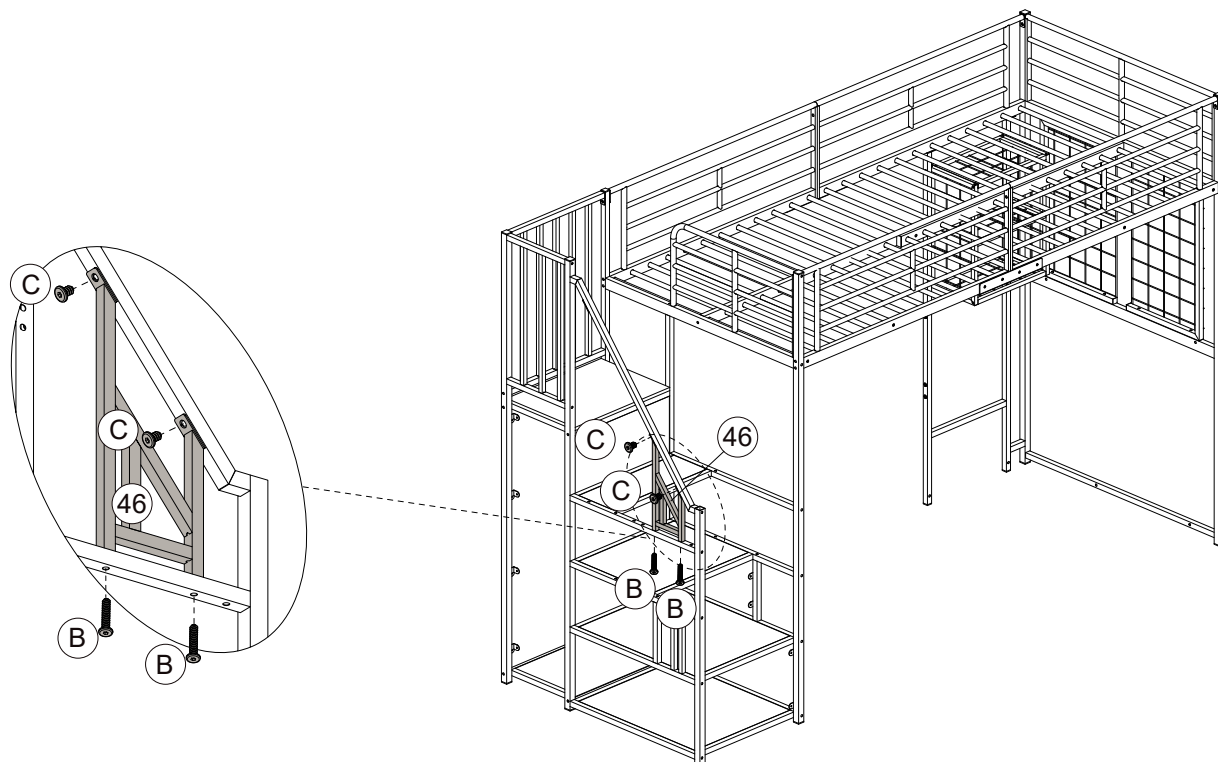

STEP 34

B		M6*35	2	 
C		M6*10	2	



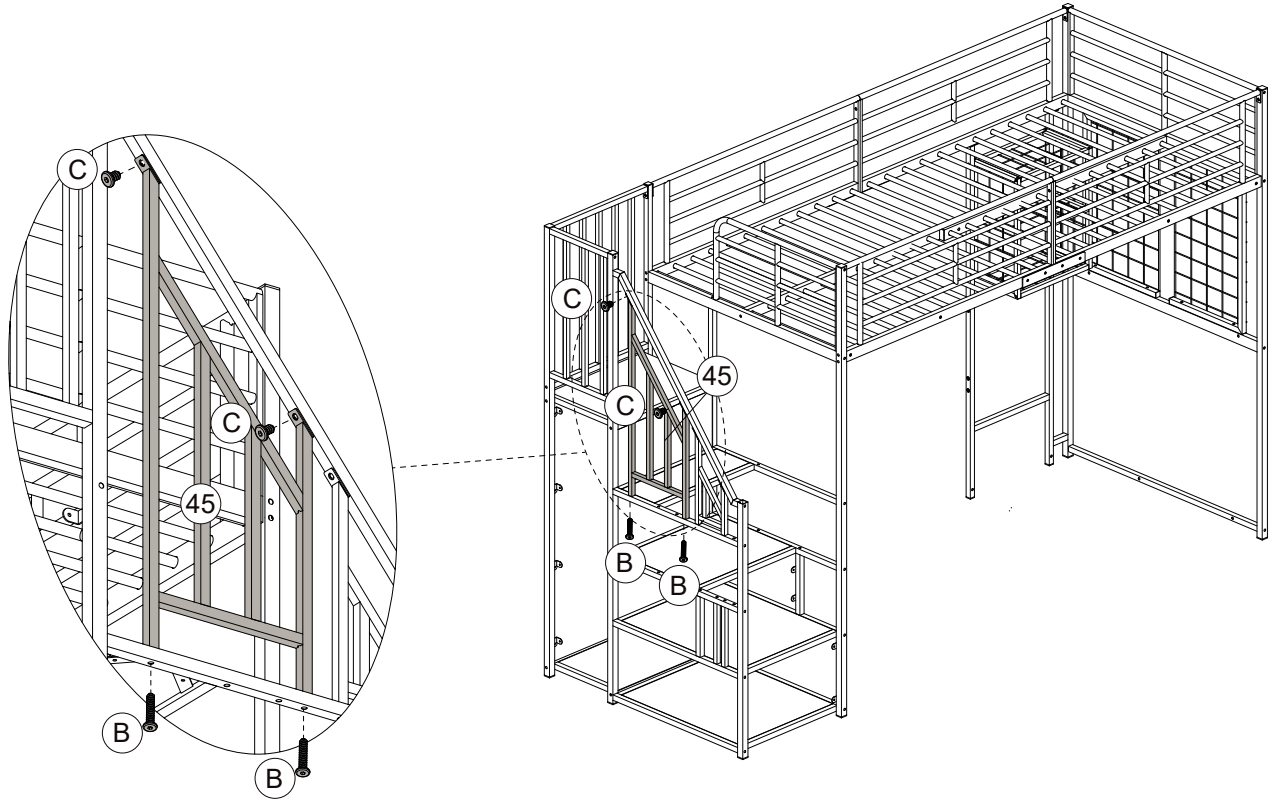

STEP 35

B		M6*35	2	 
C		M6*10	2	



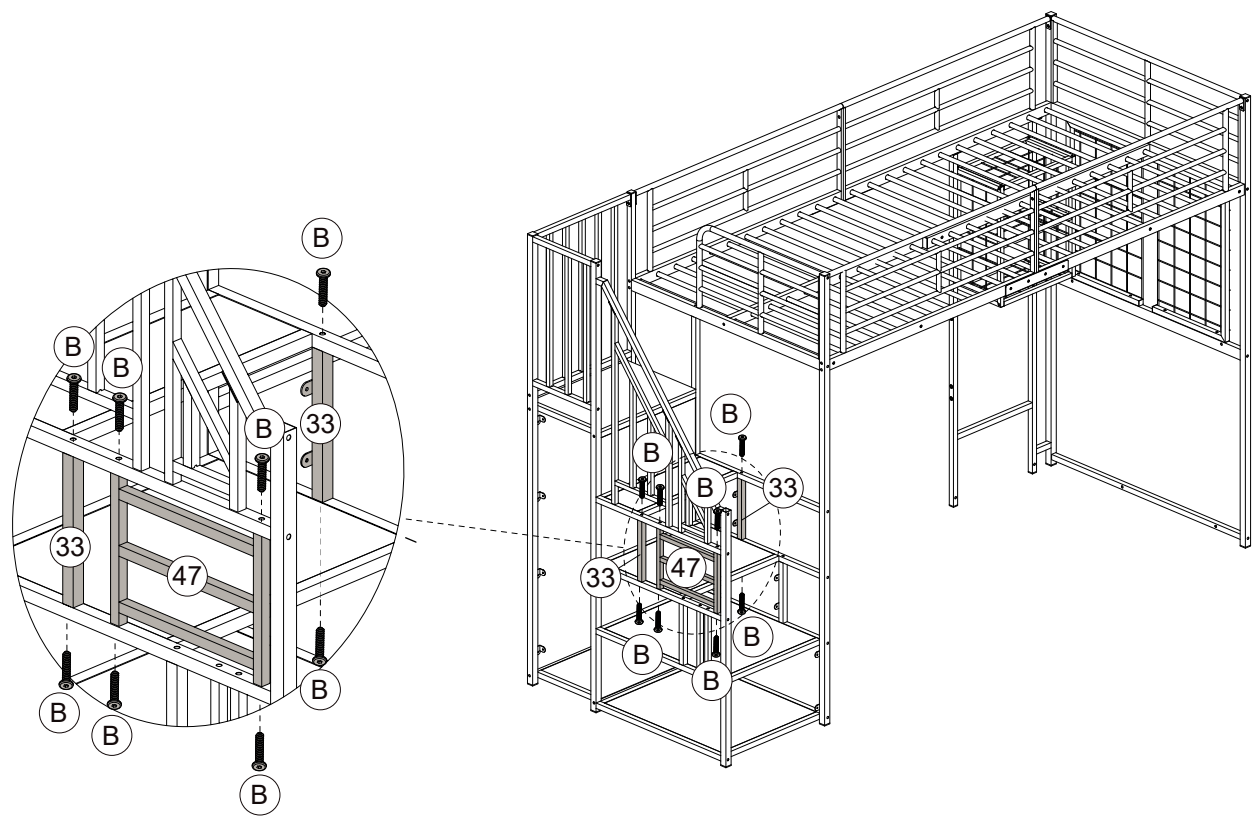

STEP 36

B		M6*35	8	 
---	---	-------	---	--



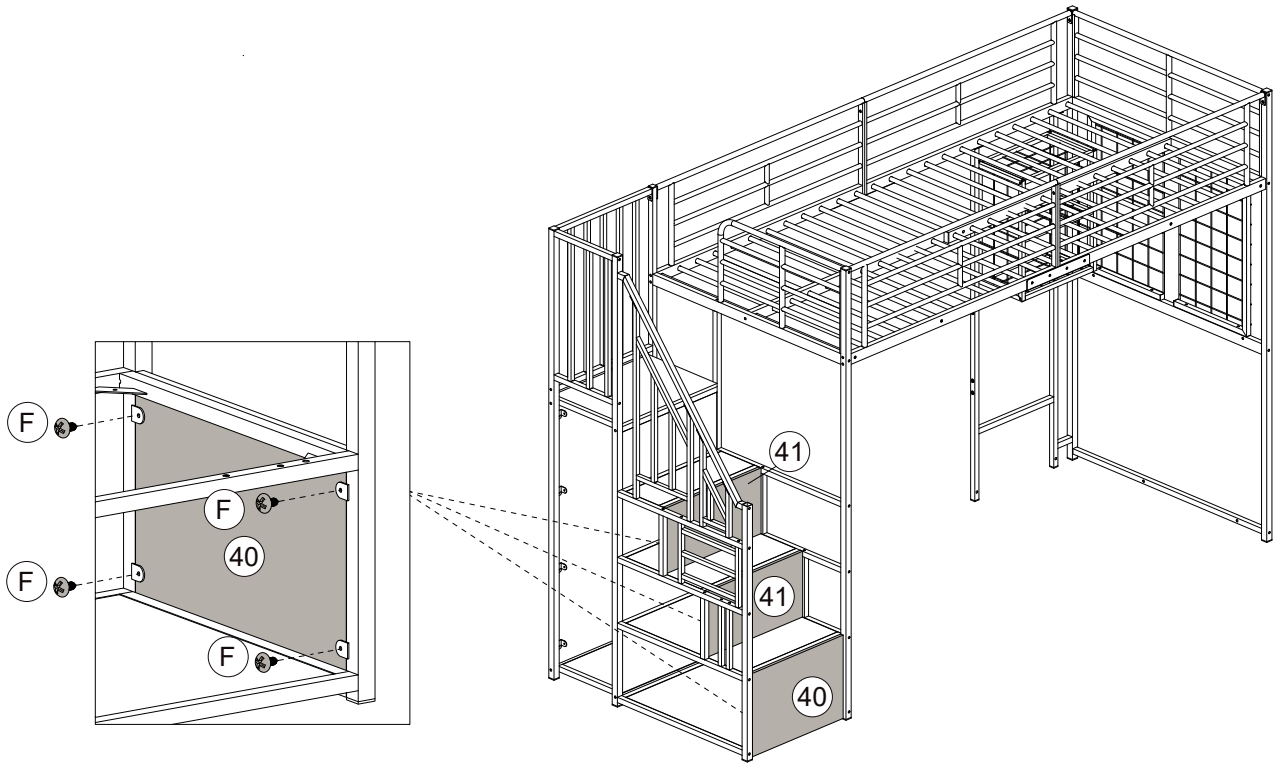

STEP 37

F		3.5*10	12	
				



STEP 38

F		3.5*10	8	
				

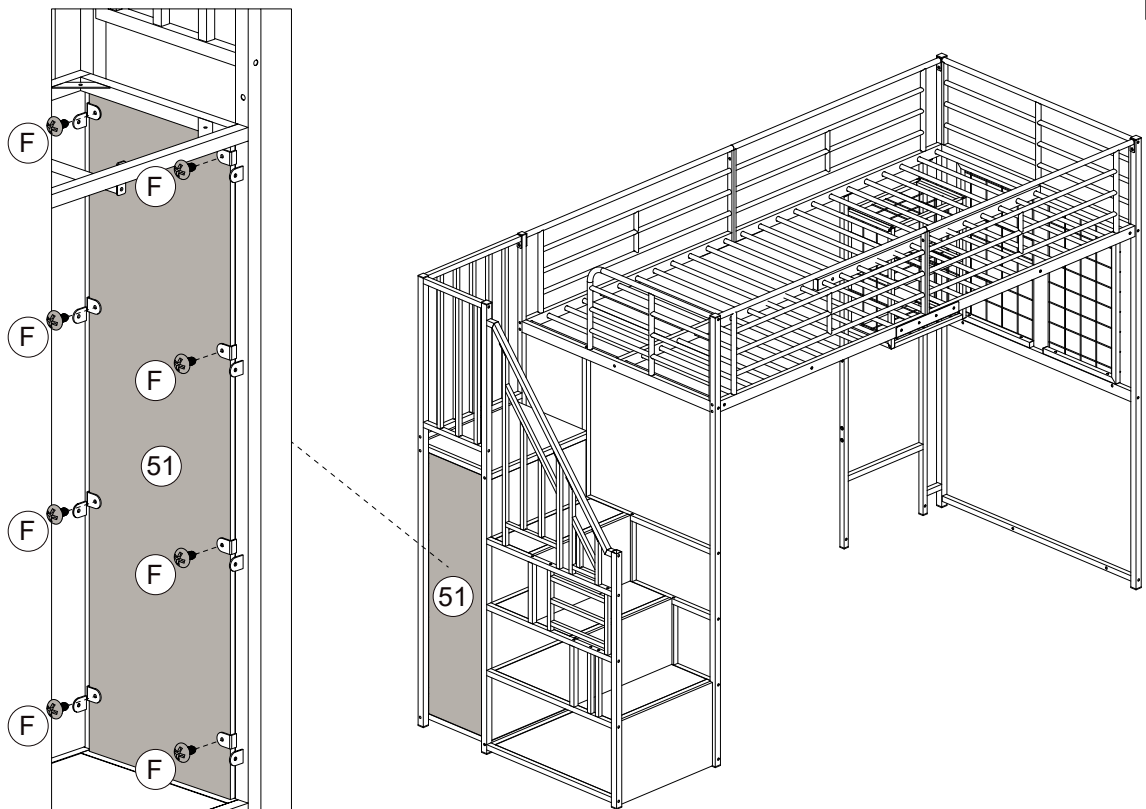

STEP 39

C



M6*10

8

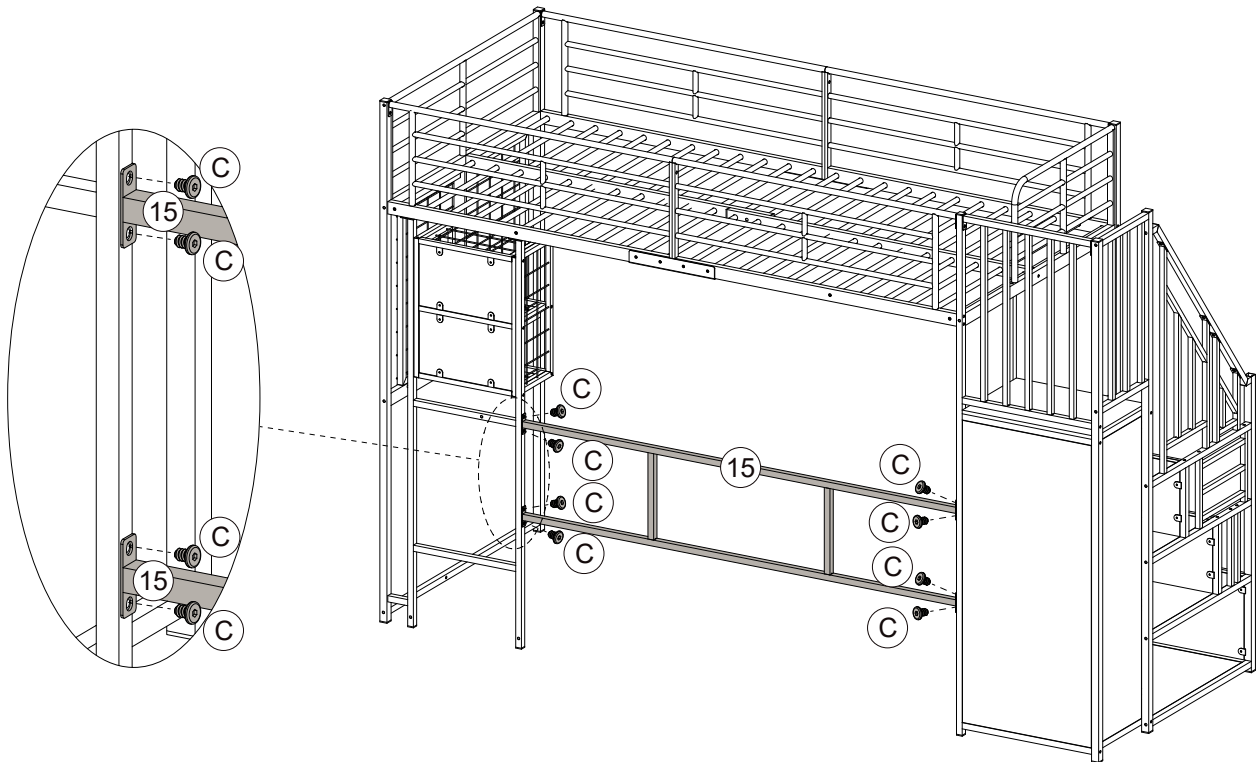

STEP 40

B



M6*35

2

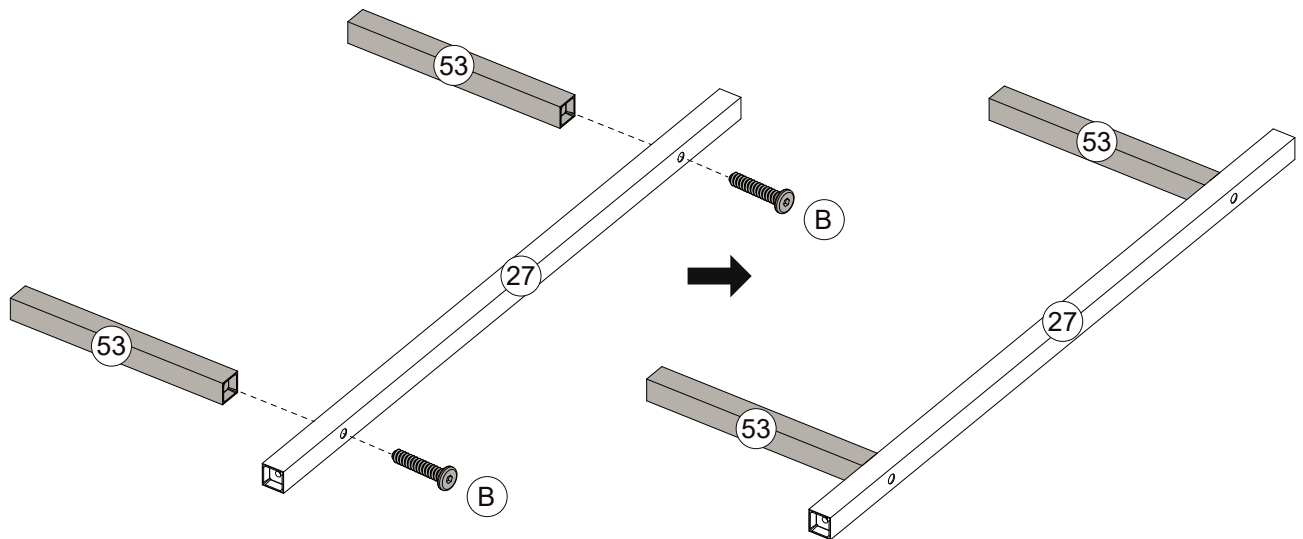

STEP 41

G		M6*35	1
---	--	-------	---

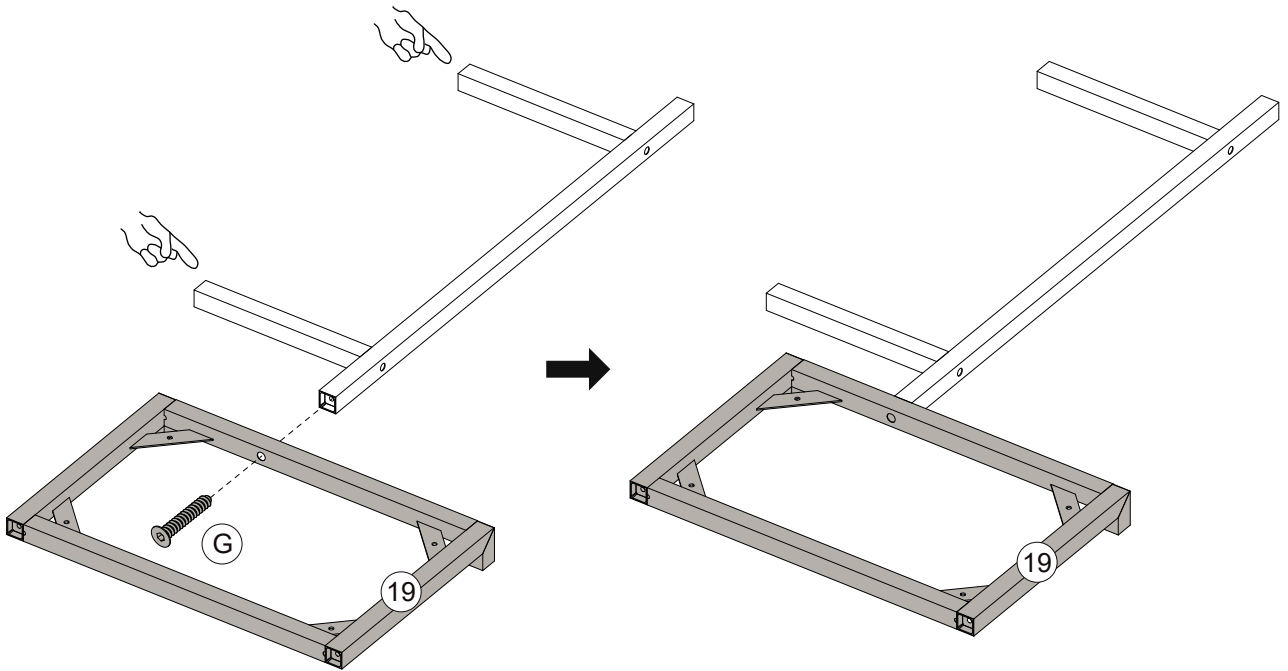

STEP 42

F		3.5*10	4
---	---	--------	---

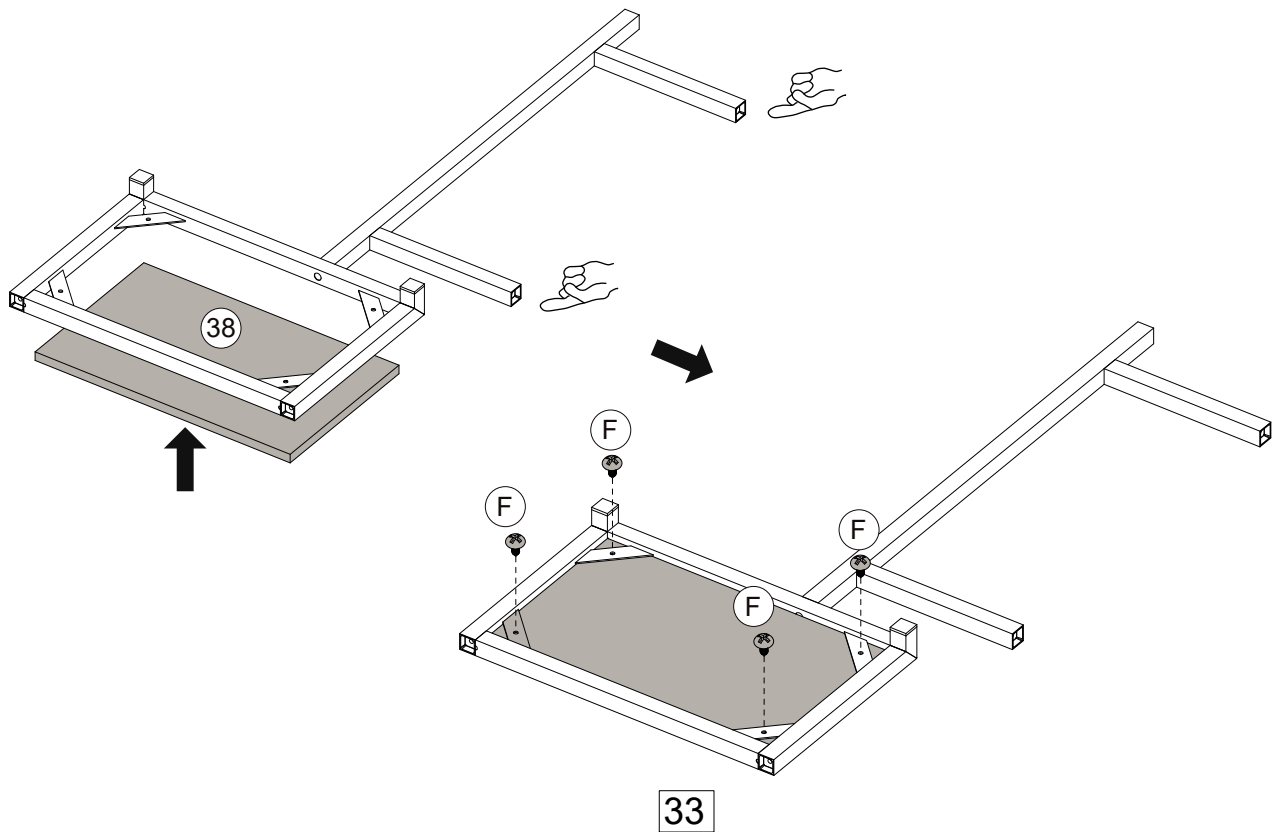
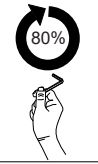

STEP 43

B		M6*35	4
---	--	-------	---

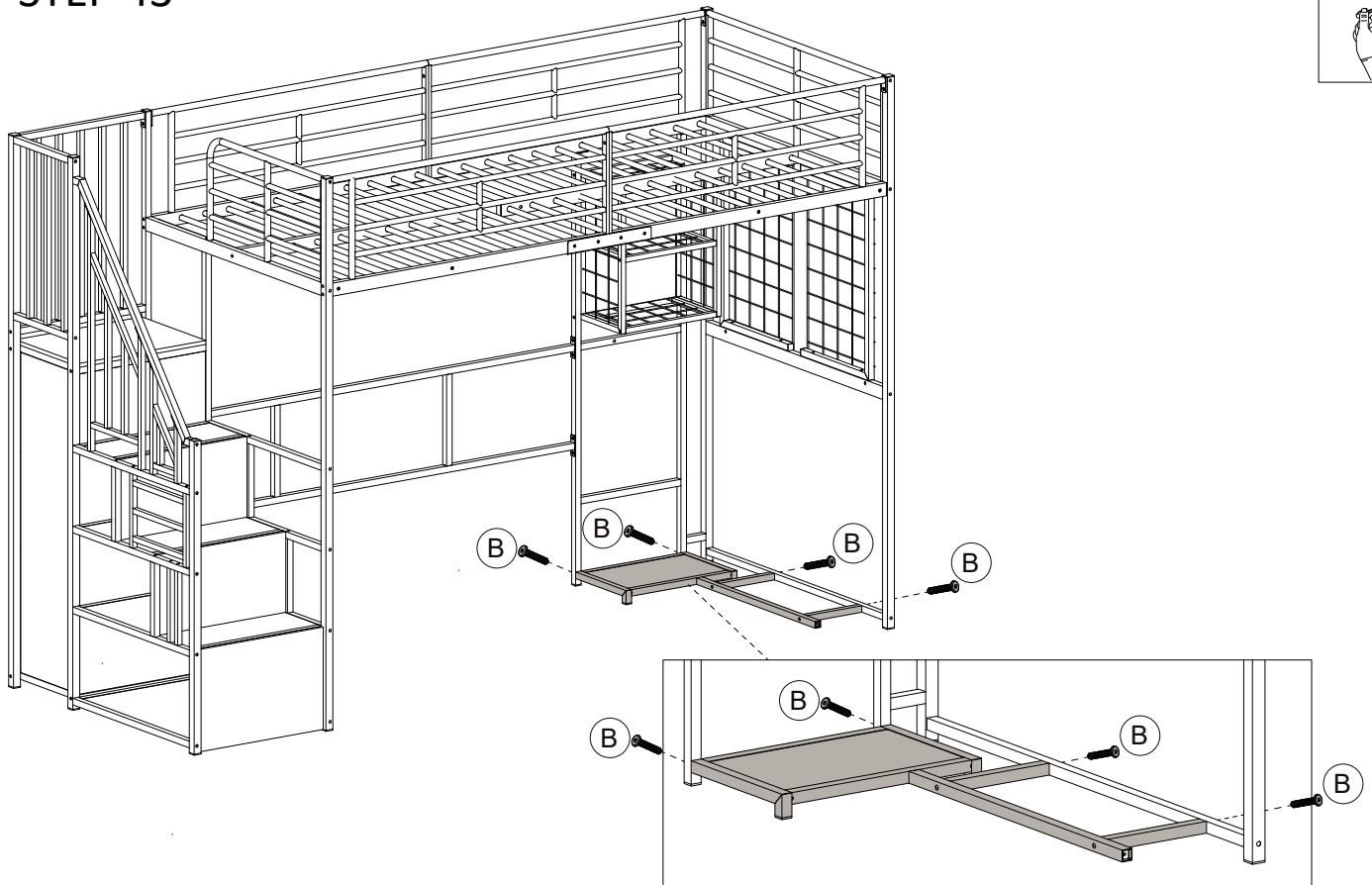

STEP 44

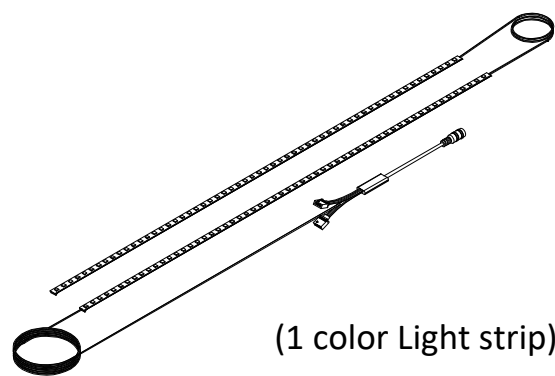
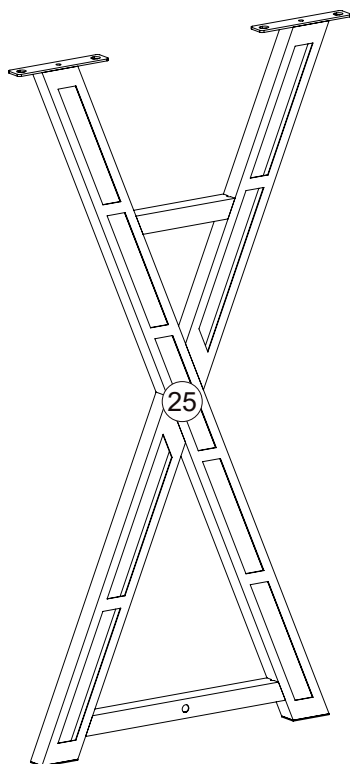

(1 color Light strip)
(1-farbiger Lichtstreifen)

STEP 45

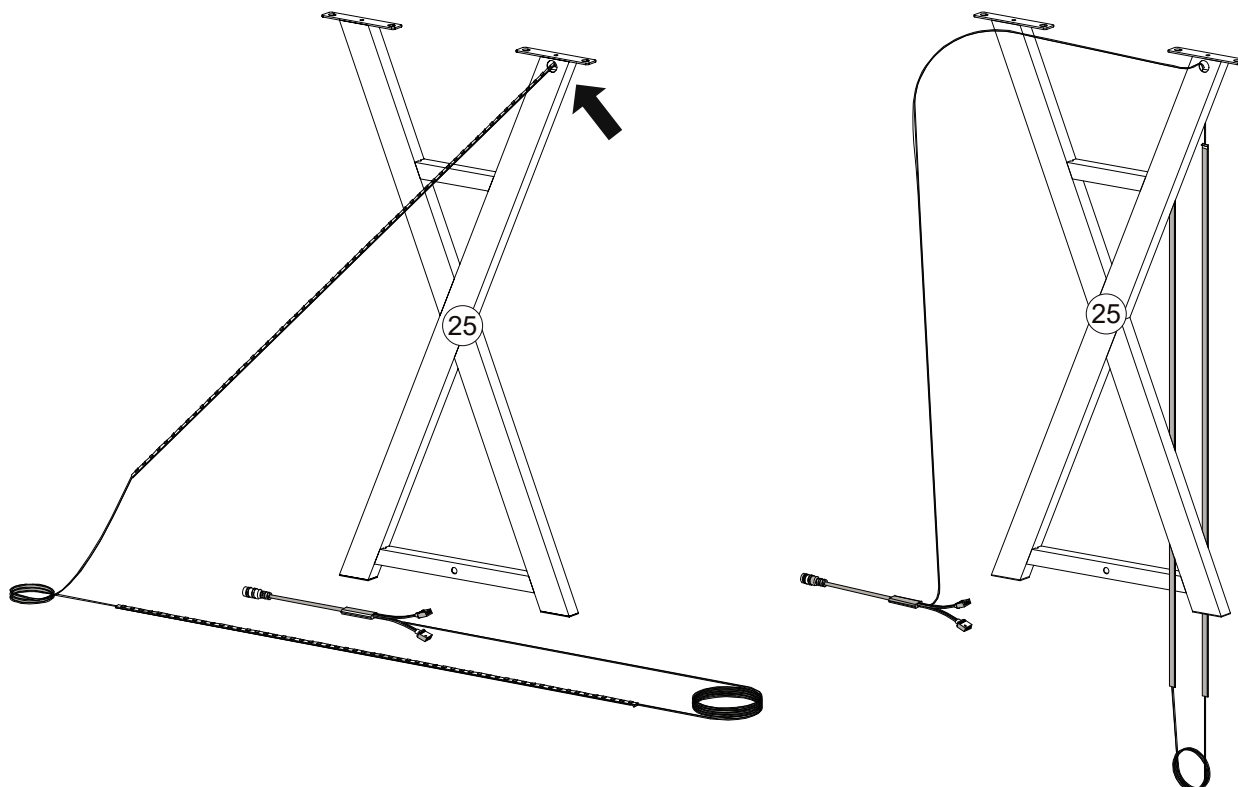

STEP 46

Remove the paper cover behind the light strip to stick it inside of the table leg.
(Entfernen Sie die Papierabdeckung hinter dem Lichtstreifen, um ihn in das Tischbein zu kleben).

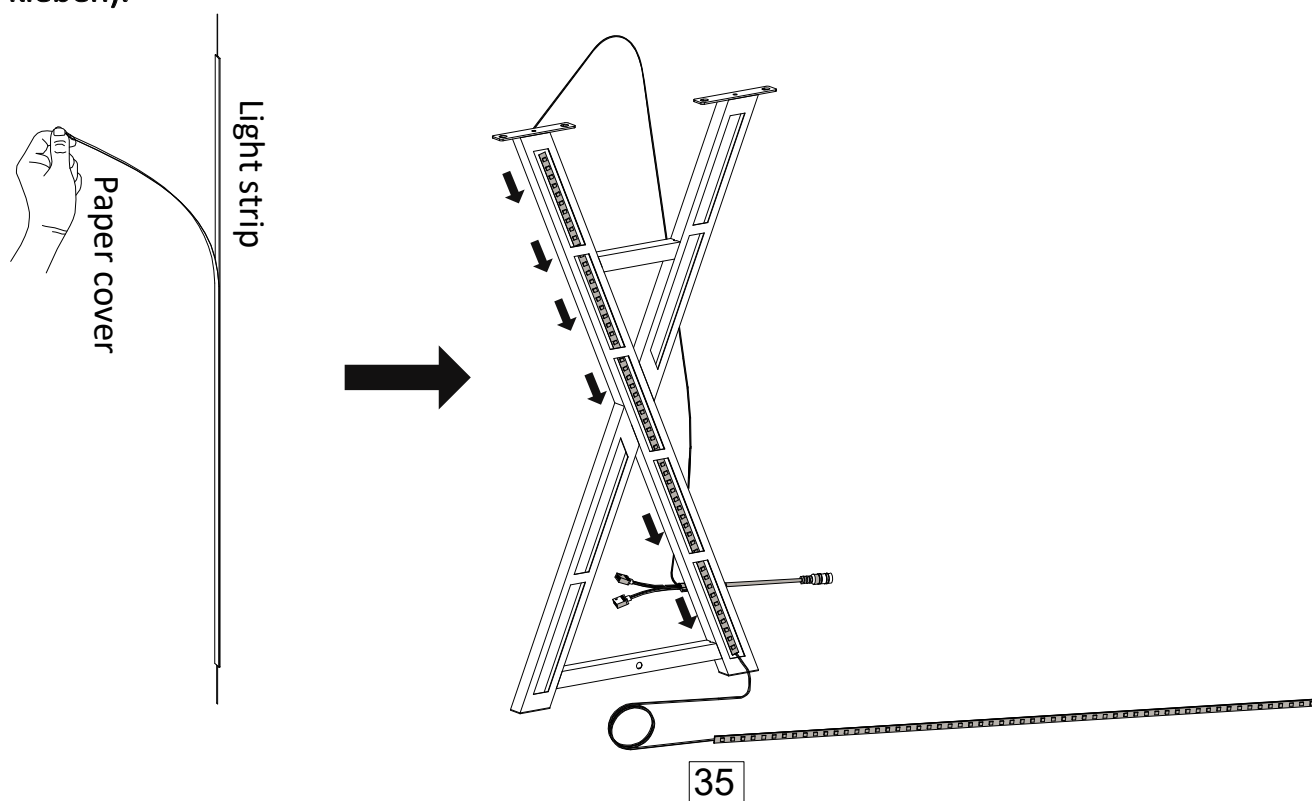

STEP 47

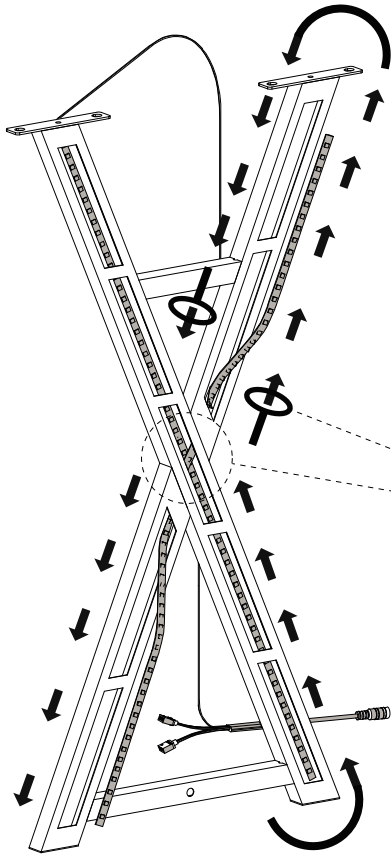

Through the hole right here,
then through back
(Durch das Loch hier,
dann durch zurück)

STEP 48

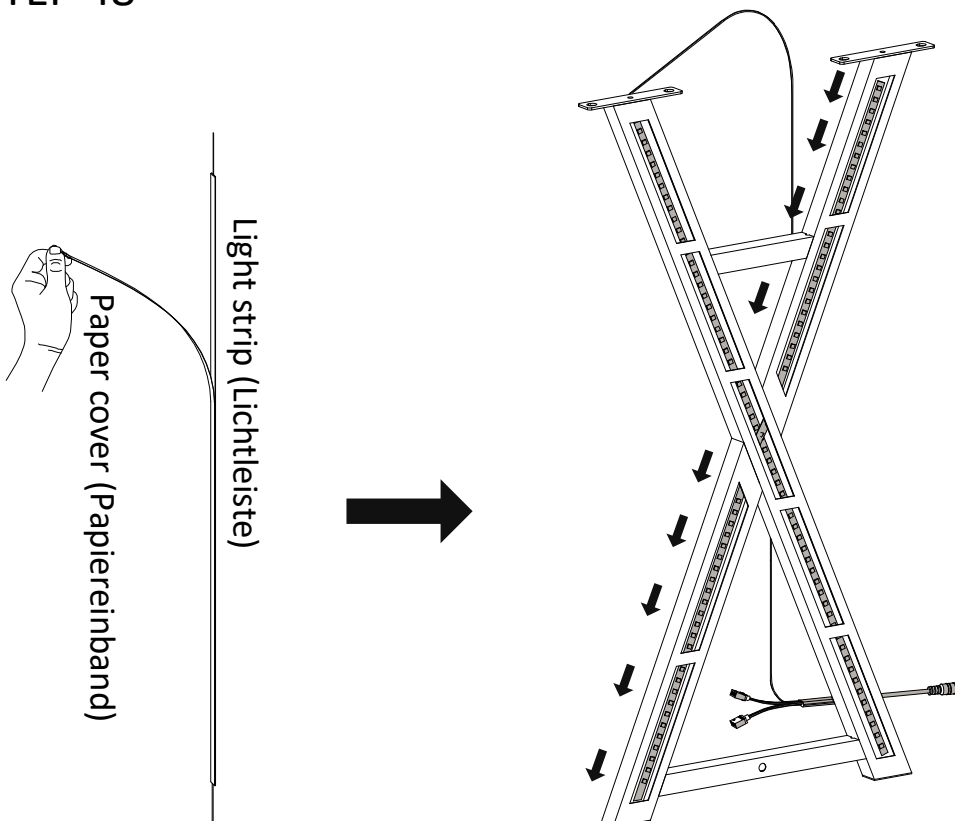

STEP 49

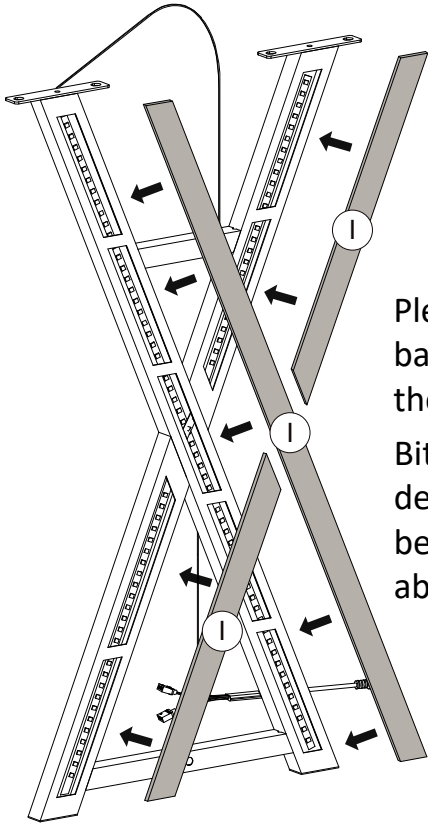

Please remove the sticker on the back of the acrylic sheet and attach the acrylic sheet to the illustrated place.

Bitte entfernen Sie den Aufkleber auf der Rückseite der Acrylplatte und befestigen Sie die Acrylplatte an der abgebildeten Stelle.

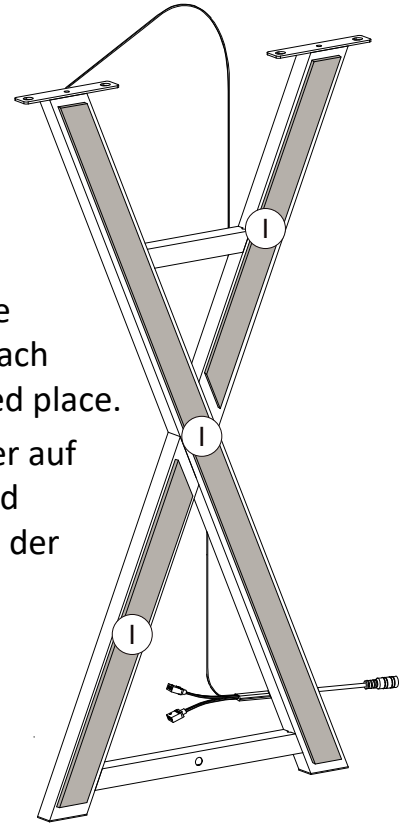

STEP 50

B





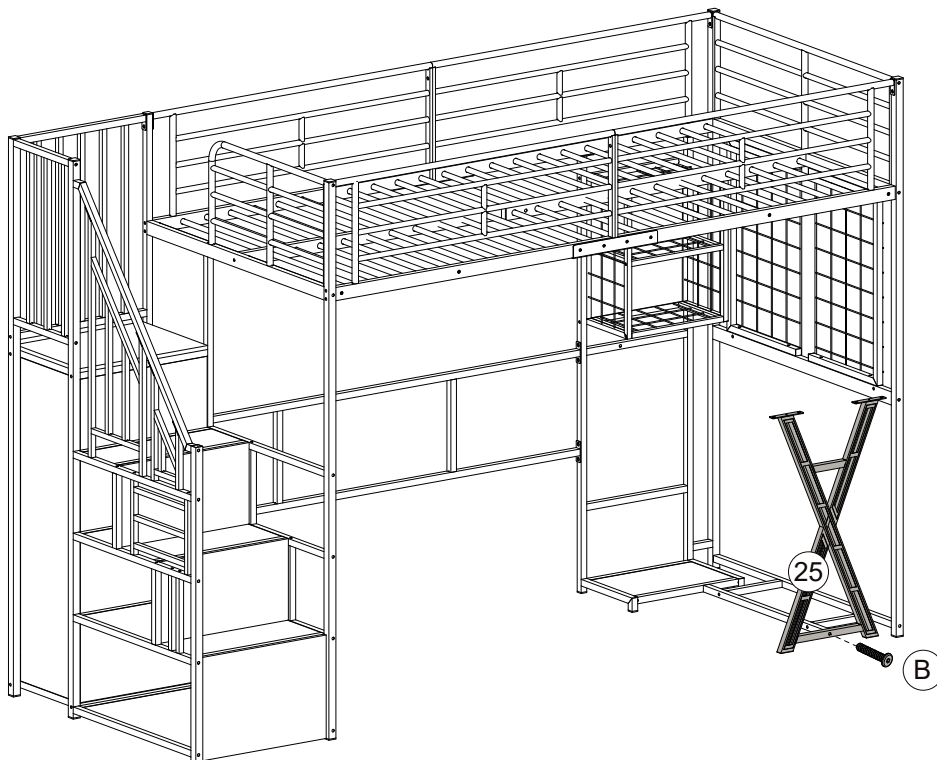

M6*35

1



STEP 51



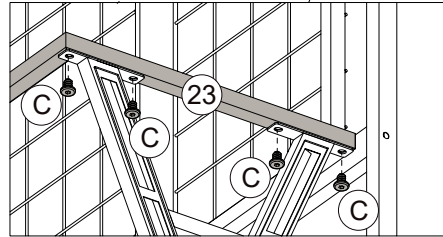
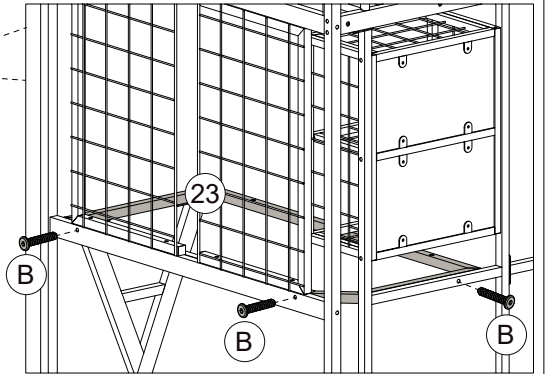

B		M6*35	3	
C		M6*10	4	

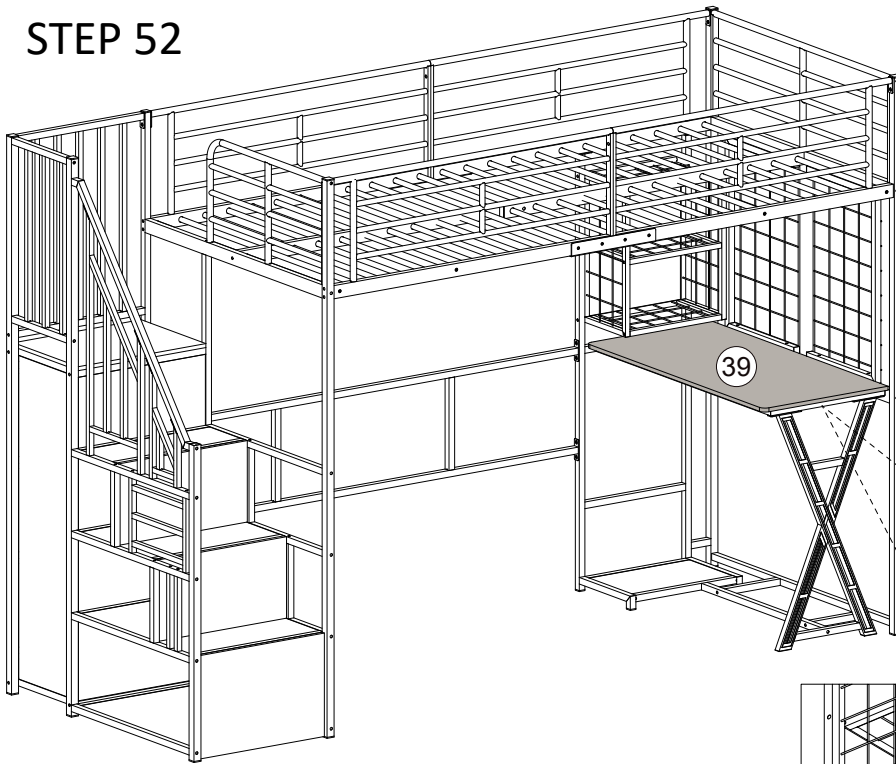

STEP 52



D		M6*28	4	
				

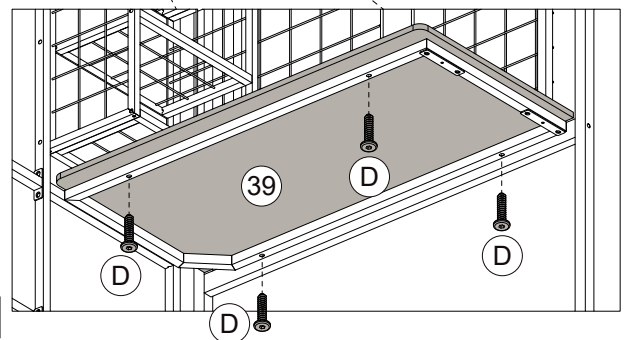

38

STEP 53

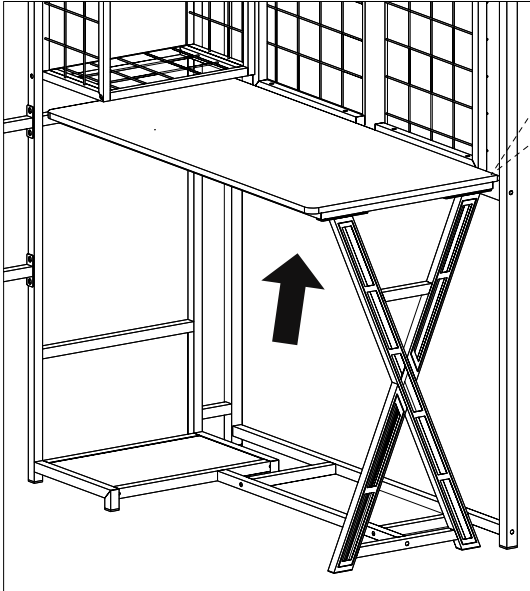

Look at under the table
(Schauen Sie unter den Tisch)

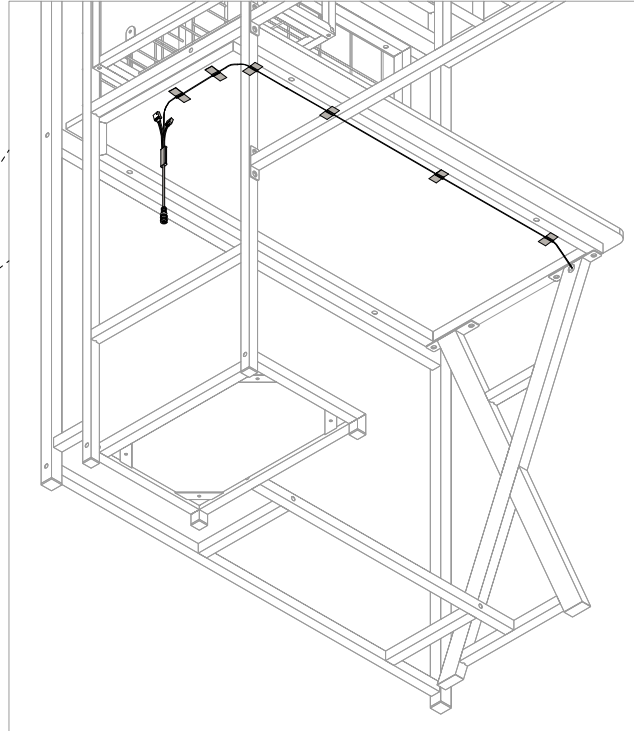

Stick the wire under the table with tape
(Kleben Sie den Draht mit Klebeband unter den Tisch)

STEP 54

Remove the paper cover behind the light strip to stick it around table top.
(Entfernen Sie die Papierabdeckung hinter dem Lichtstreifen, um ihn um die Tischplatte zu kleben).

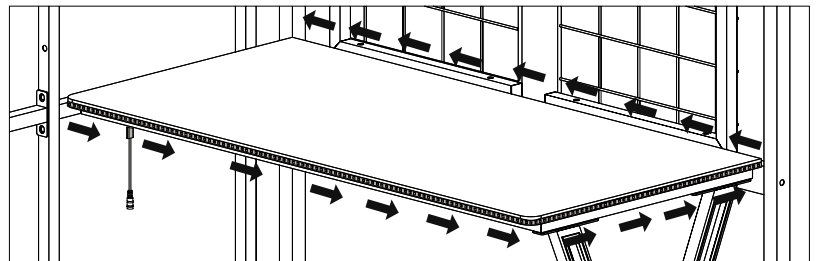
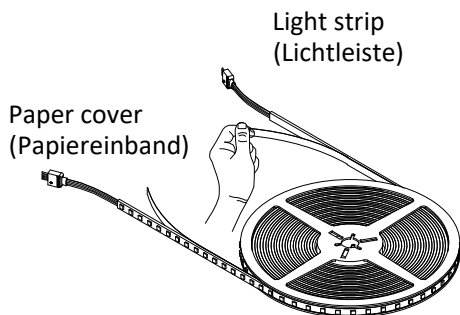

STEP 55

Remove the paper cover behind the light strip to stick it inside and around the shelf.
(Entfernen Sie die Papierabdeckung hinter dem Lichtstreifen, um ihn im Inneren und um das Regal herum anzubringen).

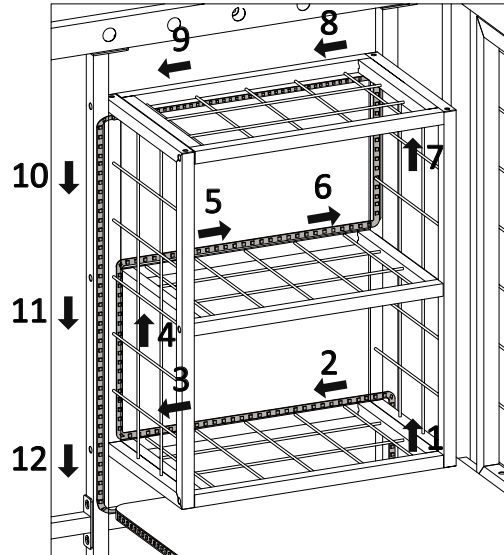

STEP 56

Connect the adapter, 7-colors RGB light strip and 1-color light strip together.
(Verbinden Sie den Adapter, den 7-Farben-RGB-Lichtstreifen und den 1-Farben-Lichtstreifen miteinander).

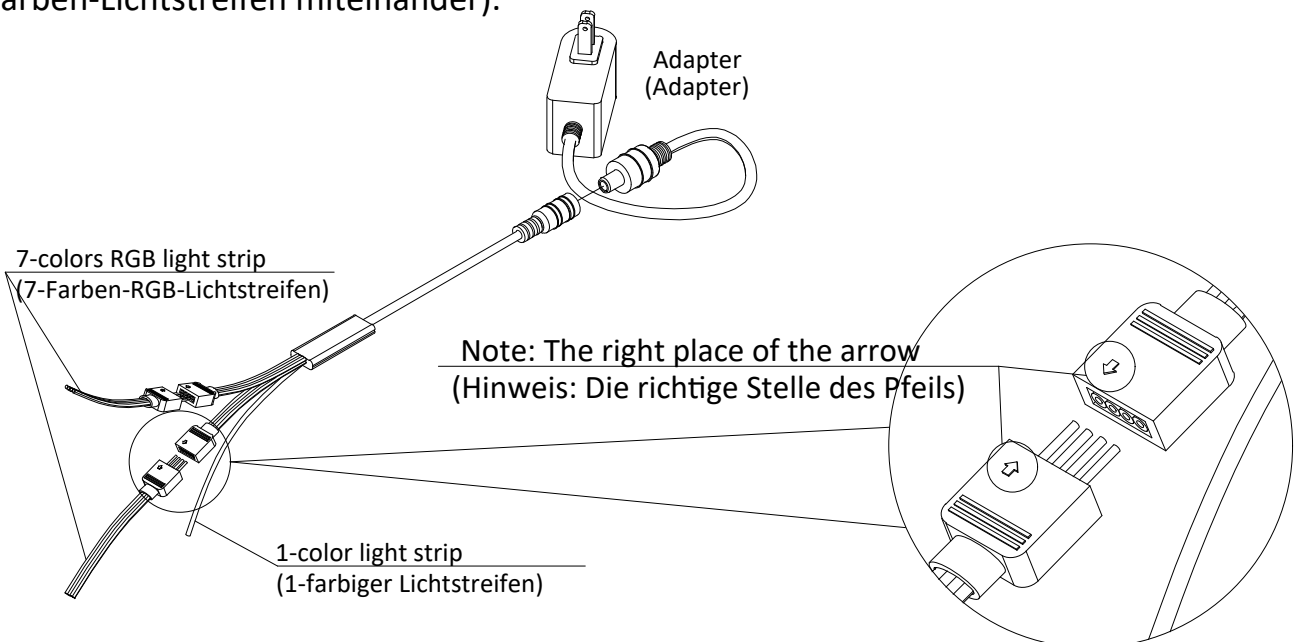



COMPLETE (VOLLSTÄNDIG)

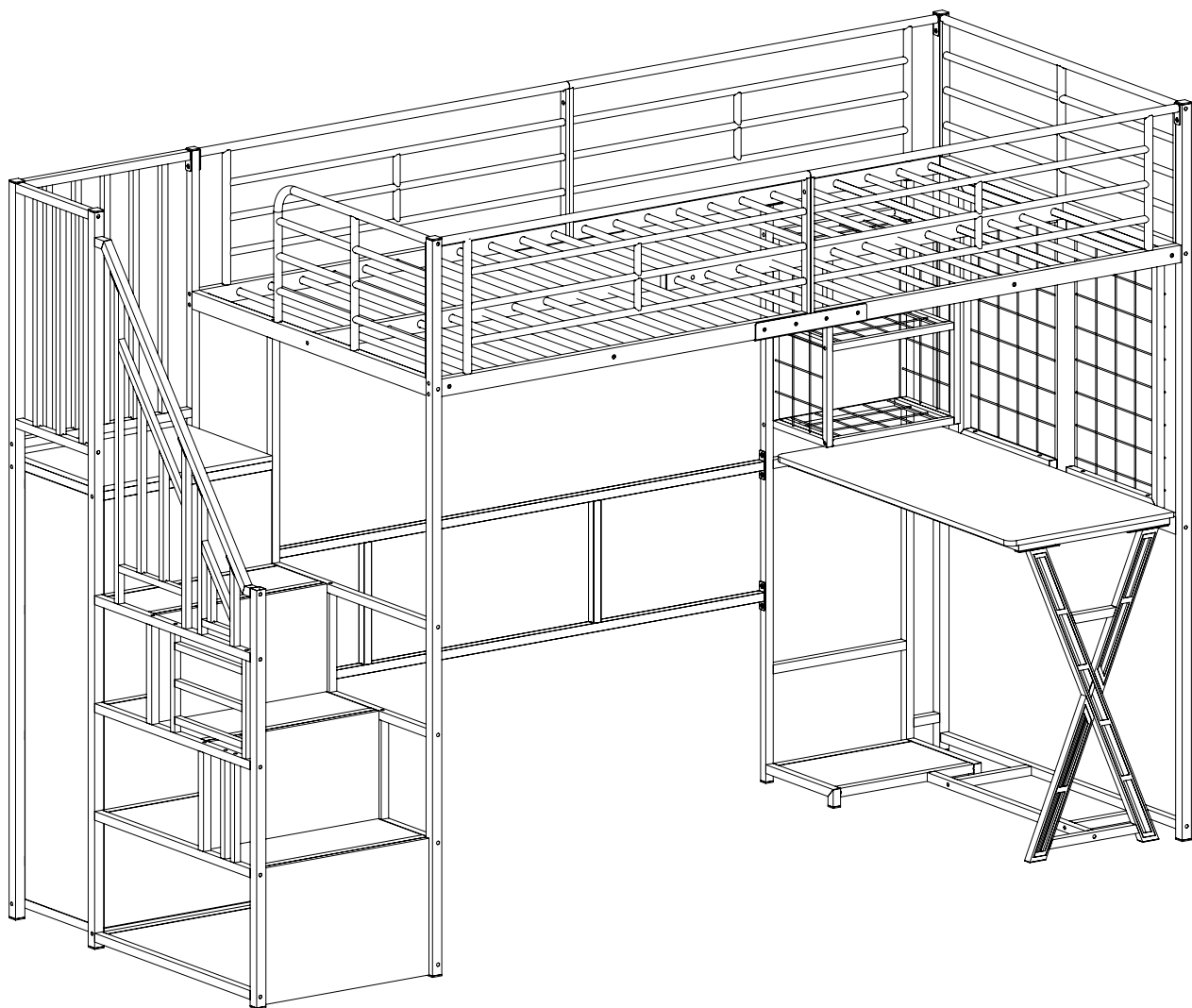

FR
Cet appareil,
ses cordons,
et batterie
se recyclent

À DÉPOSER
EN MAGASIN

OU

À DÉPOSER
EN DÉCHÈTERIE



1、 Bluetooth Connection

For the first time you use it or never pair with 'Happy Lighting' after moving the equipment, please following the below steps:

A、 First, please enter your phone settings, open the Bluetooth, searching and pairing with the 'Happy Lighting'.

B、 Second, Open the Happy Lighting led app, the app will auto to connect the BLE light.



2、 Main User Interface



A、 Adjust: Change the RGB LED color and White LED bright.



B、 Music: Play music and change RGB LED color by music rhythm.

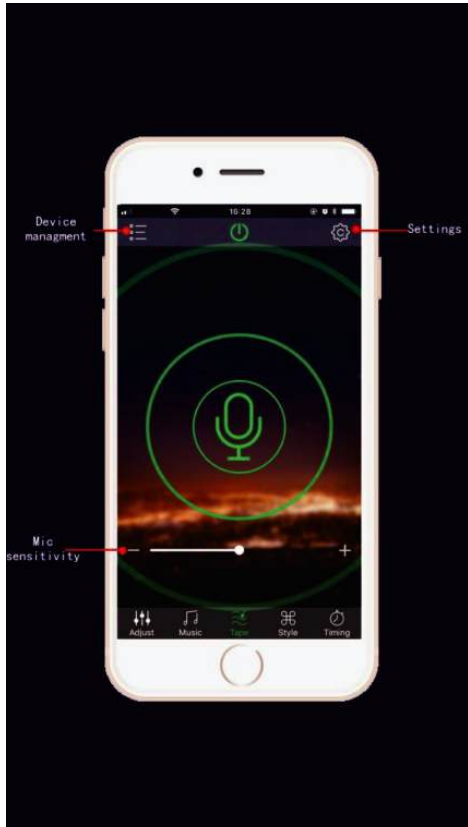

C、 Mood: Change RGB LED color by phone microphone input voice rhythm.

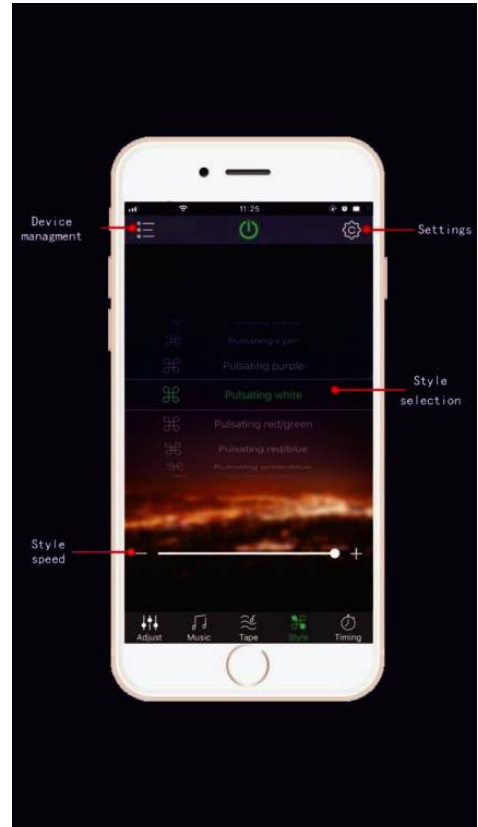

D、 Patterns: Change RGB LED color by fixed model.



E、 Schedules: Timers, auto ON/OFF.

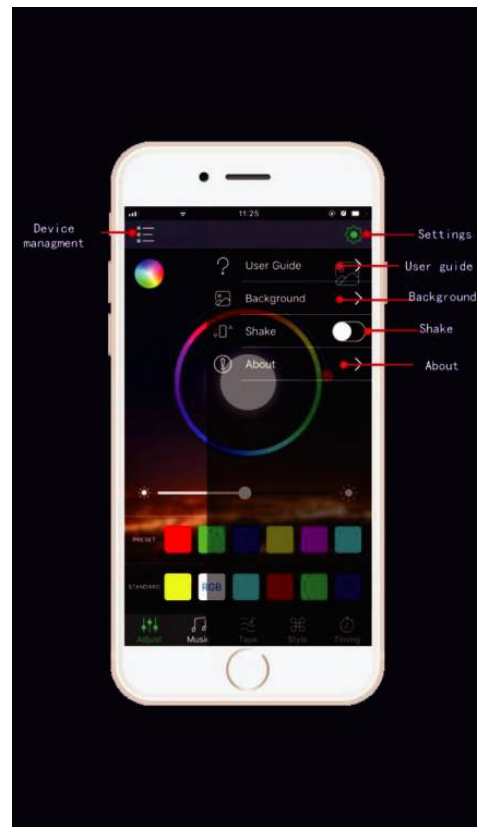

F、 Setting: Shake: Change RBG LED color by shake the phone; Music Hop: RBG LED color changed by music.

3、Specification

NO.	Item	Parameter
	Input Voltage(V)	100-240V/50-60HZ
	Input Power(W)	<9W
	Power Factor (PFC)	>90%
LED light indicators		
	Lamp Power(W)	<5W
	Lumen Ratio(K)	>400,5W power consumption
	CRI	White>0.75; Warm white>0.85
	Color Temperature(IF)	3000-6500,Tolerance: \pm 500K
	Light Decay	<10%,T=25°C; RH=90%; H=20000
	Illumination Angle	>90°,According to customers request
	Dimming	PWM
Audio amplifier indicators		
	Audio Power (W)	3W,THD+N=10%, 1KHz
	Frequency Response	40HZ-18KHZ, Nonuniformity: \pm 3dBm
	Audio Distortion(HTD+N)	<1%,P=1W;A-weight
	Volume Control	Phone key or Audio APP
	Bluetooth Distance	0~15m,Straight line distance and no obstacles
The use of ambient temperature		
	Working Temperature(°C)	-20-60
	Storage Temperature	-40-70

4、Note:

- ★ If you can't search your Bluetooth bulb device or can't connect with the Bluetooth lamp device for a long time, please enter your phone 'setting' and connect again;
- ★ If you can't connect to the device for a long time or other abnormal ,please close the APP ,then try to restart;
- ★ Do not put the bulb in closed lampshade;
- ★ Do not put the bulb in the place which is humid or has water;
- ★ Keep using it under the power supply of 90V to 240V AC,50-60Hz;
- ★ This bulb is not a toy and keep it untouchable to children;
- ★ Do not put the bulb on high-temperature surface;
- ★ Do not open any sealing device for safety and according to Warranty Terms;
- ★ Cool down the bulb before replacing it to avoid electric shock or burning.

Happy Lighting
Smart lamp with Speaker
User Manual

This product has a unique and exclusive two-in-one design – the smart LED lamp and Bluetooth stereo audio speaker. Bluetooth 4.0+EDR(Enhanced data rate) and purity and definition of particular voice based on DSP technology. Wish you have infinite joy from the combination of light and music.



Scan the QR-Code to download the APP

DE: Wenn Sie die Lichter nicht erfolgreich arbeiten lassen können, überprüfen Sie bitte die Folgendes:

1. Bitte überprüfen Sie die Fernbedienung. Sie müssen die Fernbedienung abreißen Plastikseptum vor Gebrauch.
2. Lassen Sie die Fernbedienung nicht zu weit vom Empfänger entfernt sein Es gibt kein Hindernis zwischen ihnen.
3. Bitte beachten Sie, dass die Fernbedienung für den Transport keine Batterien enthält. Das Batteriemodell lautet: CR2025

FR: Si vous ne parvenez pas à faire fonctionner les lumières correctement, veuillez vérifier les points suivants?:

1. Veuillez vérifier la télécommande. Vous devez retirer le septum en plastique de la télécommande avant utilisation.
2. Ne laissez pas la télécommande être trop éloignée du récepteur. Il n'y a aucun obstacle entre eux.
3. Veuillez noter que la télécommande ne contient pas de piles pour le transport. Le modèle de batterie est?: CR2025

UK: If you can't make the lights work successfully, please check the following:

1. Please check the remote control. You need to tear off the remote plastic septum before use.
2. Don't let the remote control be too far from the receiver There is no obstacle between them.
3. Please note that the remote control does not contain batteries for transportation. The battery model is: CR2025



Ankel Testing (DongGuan) Co.,Ltd

Test Verification of Conformity

Report No.: ANL24040102-F

Applicant: DA TANG LIGHTS TECHNOLOGY CO., LTD
Address: No.688, KP4. AnFu Electronic Industrial.SHUN'AN COUNTY Binh Duong, VIETNAM
Manufacturer: DA TANG LIGHTS TECHNOLOGY CO., LTD
Address: No.688, KP4. AnFu Electronic Industrial.SHUN'AN COUNTY Binh Duong, VIETNAM
Product: AC/DC ADAPTER
Model No.: DT-20, DT-21, DT-22, DT-23, DT-24, DT-25, DT-26, DT-27, DT-28, DT-30
Technical Data: Input: 100-240VAC, 50/60Hz
Output: 12VDC, 1.0A

FCC Rules Specifications

FCC CFR47 Part15 Subpart B (2017)

The above product has been tested by us with the listed standards and found in compliance with the Code of Federal Regulations, Title 47-Telecommunications, FCC Rules of 2.906, 2.908, 2.909 and Regulations Part 15 (2017), Subpart B and the measurement Procedure according to ANSI C63.4:2014. It is possible to use FCC marking to demonstrate the compliance with this FCC Rules.

Supplementary Information:

The product herewith has been successfully tested according to the Code of Federal Regulations, Title 47-Telecommunications. This device complies with Part 15 of the FCC Rules. Operation of the product is subject to the following two conditions:

(1) This device may not cause harmful interference, and (2) this device must accept any interference received, including interference that may cause undesired operation.

The statement is based on a single evaluation of the sample of above mentioned products. It does not imply an assessment of the whole production.

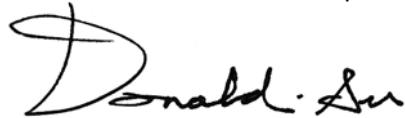

Manager

Date: April 15, 2024



Shenzhen Promise Test Technology Co., Ltd.
103, Building 1, Yibaolai Industrial City, Qiaotou Community,
Fuhai Street, Bao'an District, Shenzhen, Guangdong, China



Certificate of Compliance

Certificate NO.: PRMS2409079-02EC

Applicant : Dongguan Bestgk Smark Technology Co., Ltd
Room B F/5, Building A No.6, Xiaobu 2 Road Guanjingtou Village
Fenggang Town, Dongguan, Guangdong CHINA

Manufacturer : Dongguan Bestgk Smark Technology Co., Ltd
Room B F/5, Building A No.6, Xiaobu 2 Road Guanjingtou Village
Fenggang Town, Dongguan, Guangdong CHINA

Trade Mark : N/A

Product : Power Supply

Rated Input : 100-240V~, 50/60Hz, 0.5A Max

Model(s) : JBT050yyy-T10EUU, SL050yyy-T10EUU (yyy=001-210, Indicating
the output current, the current range is 0.01A-2.1A, and the step
value is 0.01A.)

Test Standard : EN 55032:2015+A11:2020+A1:2020
EN 55035:2017+A11:2020
EN IEC 61000-3-2:2019+A1:2021 w
EN 61000-3-3:2013+A2:2021

The EUT described above has been tested by us with the listed standards and found in compliance with the council EMC Directive 2014/30/EU. It is possible to use CE marking to demonstrate the compliance with this EMC Directive. It is only valid in connection with the test report number: PRMS2409079-02ER.



This Certificate of Conformity is based on single evaluation of the submitted sample(s) of the above mentioned product. It does not imply an assessment of the whole product and relevant . Directives have to be observed.

+86-0755-23319501

info@pnms-test.com

www.pnms-test.com



This authorizes the application of the Certification Mark(s) shown below to the models described in the Product(s) Covered section when made in accordance with the conditions set forth in the Certification Agreement and Listing Report. This authorization also applies to multiple listee model(s) identified on the correlation page of the Listing Report.

This document is the property of Intertek Testing Services and is not transferable. The certification mark(s) may be applied only at the location of the Party Authorized To Apply Mark.

Applicant:	DA TANG LIGHTS TECHNOLOGY CO., LTD	Manufacturer:	DA TANG LIGHTS TECHNOLOGY CO., LTD
Address:	No.688, KP4. AnFu Electronic Industrial. SHUN'AN COUNTY Binh Duong	Address:	No.688, KP4. AnFu Electronic Industrial. SHUN'AN COUNTY Binh Duong
Country:	VIETNAM	Country:	VIETNAM
Party Authorized To Apply Mark:	Same as Manufacturer		
Report Issuing Office:	Intertek Testing Services Ltd. Zhejiang		
Control Number:	<u>5014346</u>	Authorized by:	_____
			for L. Matthew Snyder, Certification Manager



This document supersedes all previous Authorizations to Mark for the noted Report Number.

This Authorization to Mark is for the exclusive use of Intertek's Client and is provided pursuant to the Certification agreement between Intertek and its Client. Intertek's responsibility and liability are limited to the terms and conditions of the agreement. Intertek assumes no liability to any party, other than to the Client in accordance with the agreement, for any loss, expense or damage occasioned by the use of this Authorization to Mark. Only the Client is authorized to permit copying or distribution of this Authorization to Mark and then only in its entirety. Use of Intertek's Certification mark is restricted to the conditions laid out in the agreement and in this Authorization to Mark. Any further use of the Intertek name for the sale or advertisement of the tested material, product or service must first be approved in writing by Intertek. Initial Factory Assessments and Follow up Services are for the purpose of assuring appropriate usage of the Certification mark in accordance with the agreement, they are not for the purposes of production quality control and do not relieve the Client of their obligations in this respect.

Intertek Testing Services NA Inc.
545 East Algonquin Road, Arlington Heights, IL 60005
Telephone 800-345-3851 or 847-439-5667 Fax 312-283-1672

Standard(s):	Audio/Video, Information and Communication Technology Equipment - Part 1: Safety Requirements [UL 62368-1:2019 Ed.3+R:22Oct2021] Audio/Video, Information and Communication Technology Equipment - Part 1: Safety Requirements [CSA C22.2#62368-1:2019 Ed.3+U1]
Product:	SWITCHING ADAPTER
Models:	DT-20, DT-21, DT-22, DT-23, DT-24, DT-25, DT-26, DT-27, DT-28, DT-30

1) Importeur	Decobus Handel GmbH
Adresse	Innungsstraße 9, 21244 Buchholz, Deutschland
Email/URL	https://www.decobusgroup.de
Hersteller	Chengcheng Intelligent Technology (Xiamen) Co., Ltd.
Adresse	No. 93, Shandingtou Li, Maxiang Street, Xiang'an District, Xiamen City
Email/URL	CCZN66@163.com
Partienumm	DC5V2A 20250707—01 KY—01
Hergestellt in	China
	Decobus Handel GmbH Innungsstraße 9, 21244 Buchholz, Deutschland https://www.decobusgroup.de

2)



3)



4) Produkt: RGB LED

Modell: CC—KY5V2A—001

Nennspannung: 5V

Nennfrequenz: 10W

Leistung: 24mhz



Points de collecte sur www.quefairedemesdechets.fr
Privilégiez la réparation ou le don de votre appareil !