

# Installation sanleitung

# Installation Instruction

# Instruction d'installation

SKU: N623P218193 / N623P218194 / N623P218195

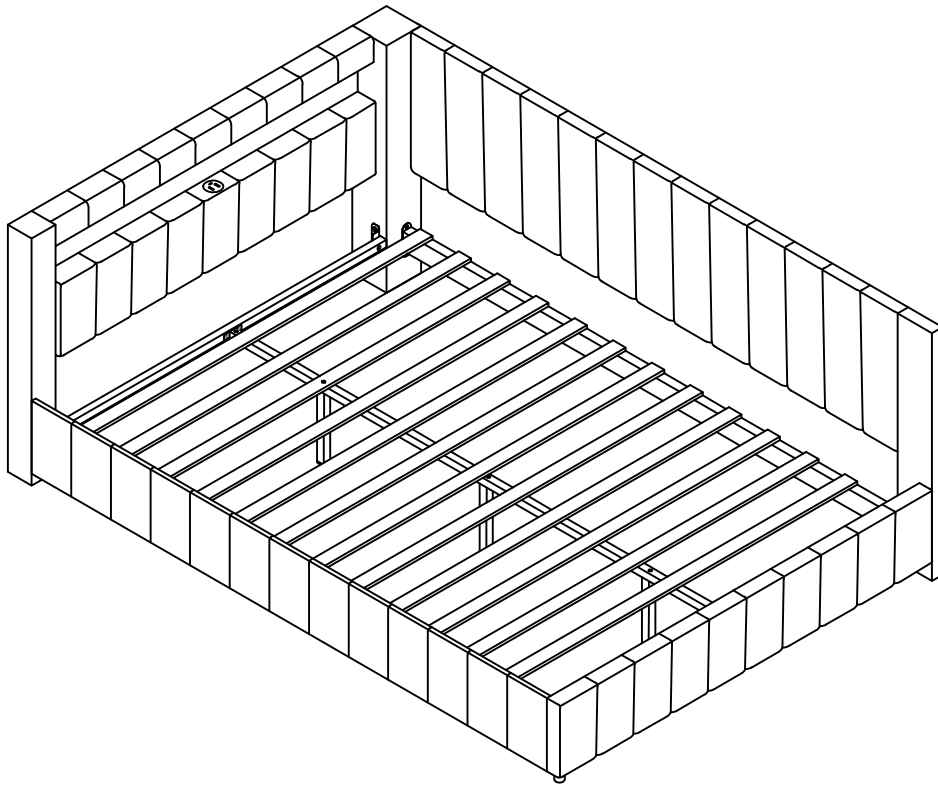

Unser Produkt wird Ihnen in 3 Paketen geliefert. Die Lieferzeiten dieser 3 Pakete können abweichen, bitte haben Sie etwas Geduld und vielen Dank für Ihr Verständnis.

Our product will be delivered to you in 3 packages. The delivery times of these 3 packages may differ, please be patient and thank you for your understanding.

Notre produit vous sera livré en 3 colis. Les délais de livraison de ces 3 colis peuvent différer, soyez patient et merci pour votre compréhension.



## English

### IMPORTANT ! KEEP FOR FUTURE REFERENCE : READ CAREFULLY

- To be assembled by an adult. Assembly must be checked by an adult before use
- WARNING ! Keep all screws, small parts and plastic bags out of the reach of children
- Properly identify all parts before assembling
- Never use your item if any of its parts are broken or missing
- Should any problems arise, please contact our After Sales Service
- Manufacturer's instructions shall be followed at all times
- Care: Clean with a soft, dry cloth. In case of larger stains, carefully rub with a slightly damp, non-abrasive sponge
- Avoid the risk of fire by not placing furniture near sources of ignition or hot items
- Do not jump on the bed

## Deutsch

### WICHTIG ! ZUM SPÄTEREN NACHSCHLAGEN AUFBEWAHREN: SORGFÄLTIG LESEN

- Muss von einem Erwachsenen zusammengebaut werden. Der Zusammenbau muss vor dem Gebrauch von einem Erwachsenen überprüft werden
- WARNUNG! Bewahren Sie alle Schrauben, Kleinteile und Plastikbeutel außerhalb der Reichweite von Kindern auf
- Kennzeichnen Sie vor dem Zusammenbau alle Teile richtig
- Benutzen Sie Ihren Artikel niemals, wenn Teile gebrochen sind oder fehlen
- Sollten Probleme auftreten, wenden Sie sich bitte an unseren Kundendienst
- Die Anweisungen des Herstellers sind stets zu befolgen
- Pflege: Mit einem weichen, trockenen Tuch reinigen. Bei größeren Flecken vorsichtig mit einem leicht feuchten, nicht scheuernden Schwamm abreiben. nicht scheuernden Schwamm
- Vermeiden Sie die Gefahr eines Brandes, indem Sie die Möbel nicht in der Nähe von Zündquellen oder heißen Gegenständen aufstellen
- Nicht auf das Bett springen

## Français

### IMPORTANT ! CONSERVER POUR RÉFÉRENCE ULTÉRIEURE : LIRE ATTENTIVEMENT

- Le montage doit être effectué par un adulte. Le montage doit être vérifié par un adulte avant Utilisation
- ATTENTION ! Tenir les vis, les petites pièces et les sachets en plastique hors de portée des enfants
- Identifiez correctement toutes les pièces avant de les assembler
- N'utilisez jamais votre article si l'une de ses pièces est cassée ou manquante
- En cas de problème, veuillez contacter notre service après-vente
- Les instructions du fabricant doivent être respectées à tout moment
- Entretien : nettoyer avec un chiffon doux et sec. En cas de taches plus importantes, frotter soigneusement avec une éponge non abrasive légèrement humide. légèrement humide et non Abrasive
- Évitez les risques d'incendie en ne plaçant pas les meubles à proximité de sources d'inflammation ou d'objets chauds
- Ne pas sauter sur le lit

## Italiano

### IMPORTANTE! CONSERVARE PER RIFERIMENTO FUTURO: LEGGERE ATTENTAMENTE

- Deve essere assemblato da un adulto. L'assemblaggio deve essere controllato da un adulto prima dell'uso
- **ATTENZIONE!** Tenere tutte le viti, le piccole parti e i sacchetti di plastica fuori dalla portata dei bambini
- Identificare correttamente tutte le parti prima dell'assemblaggio
- Non utilizzare mai l'articolo se alcune parti sono rotte o mancanti
- In caso di problemi, si prega di contattare il nostro Servizio Post Vendita
- Le istruzioni del produttore devono essere sempre seguite
- Cura: Pulire con un panno morbido e asciutto. In caso di macchie più estese, strofinare accuratamente con una spugna leggermente umida e nonspugna leggermente umida e non abrasiva
- Evitare il rischio di incendio, non collocando i mobili vicino a fonti di accensione o a oggetti caldi
- Non saltare sul letto

## Español

### ¡ IMPORTANTE ! CONSERVELO PARA FUTURAS CONSULTAS: LEA ATENTAMENTE

- Debe ser montado por un adulto. El montaje debe ser comprobado por un adulto antes del uso
- ADVERTENCIA Mantenga todos los tornillos, piezas pequeñas y bolsas de plástico fuera del alcance de los niños.
- Identifique correctamente todas las piezas antes de montarlas
  - Nunca utilice su artículo si alguna de sus piezas está rota o falta
  - Si surge algún problema, póngase en contacto con nuestro Servicio Postventa
  - Las instrucciones del fabricante deben seguirse en todo momento
  - Cuidado: Limpiar con un paño suave y seco. En caso de manchas más grandes, frote cuidadosamente con una esponja no abrasiva ligeramente humedecida.
  - Evite el riesgo de incendio no colocando los muebles cerca de fuentes de ignición u objetos calientes.
  - No saltar sobre la cama.

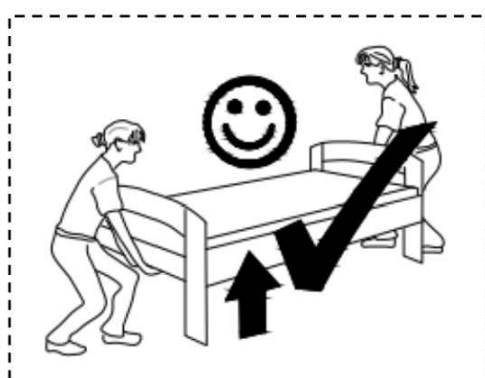

# Stückliste

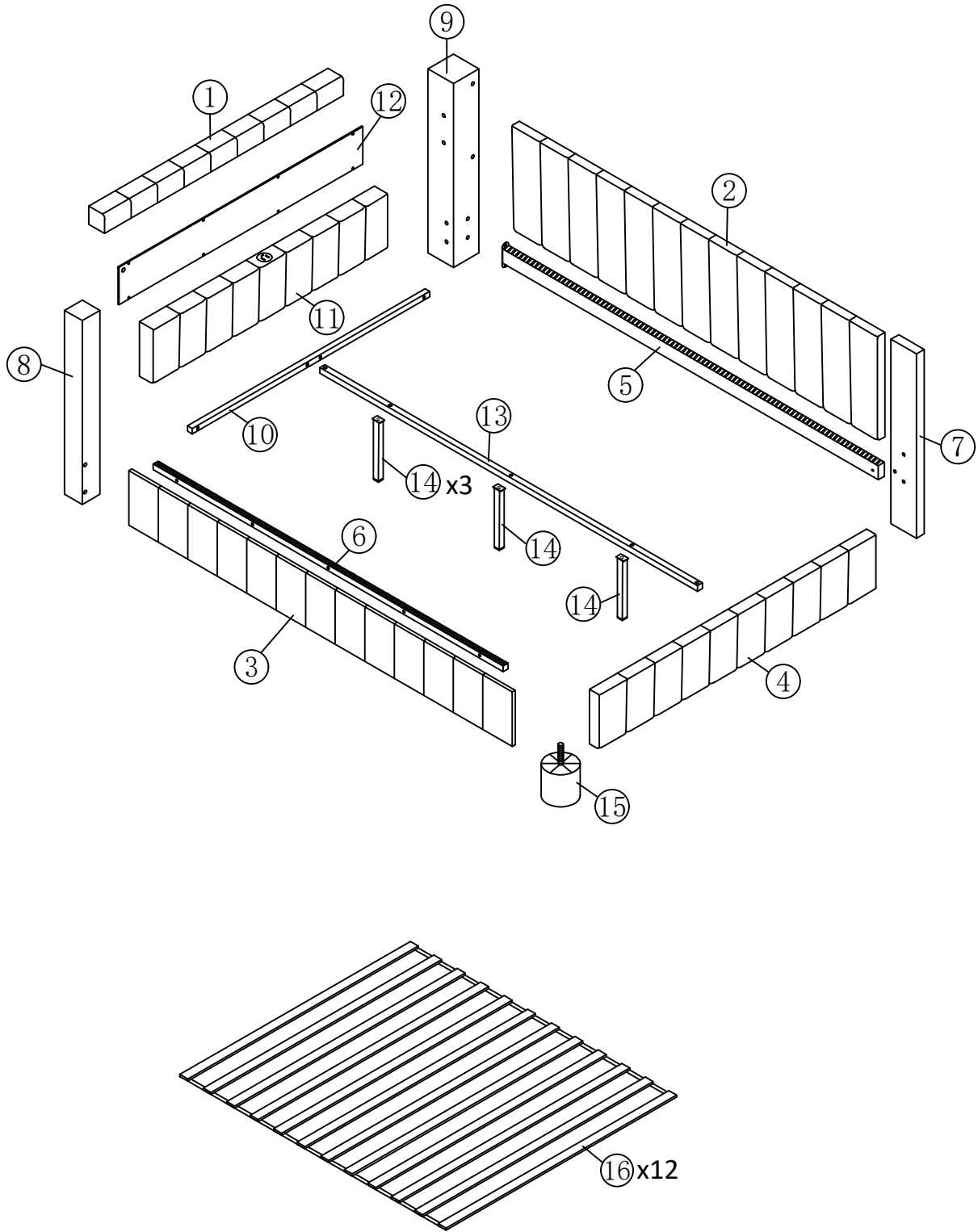



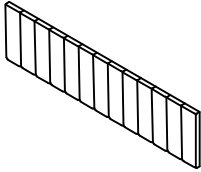
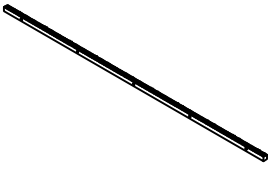
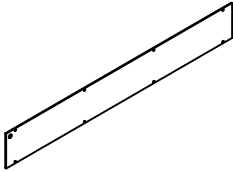
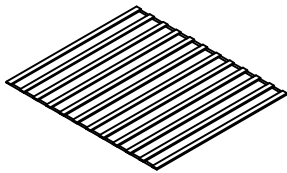

# Liste der Einzelteile



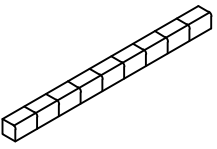
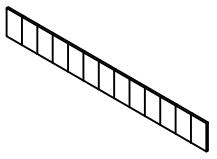

## N623P218195

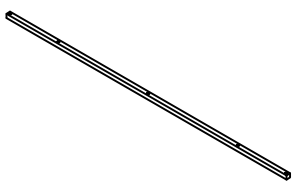
<p>② x1</p>  <p>Back rest</p>	<p>⑥ x1</p>  <p>Side rails support bar</p>	<p>⑫ x1</p>  <p>Back board</p>
<p>⑯ x12</p>  <p>Slats</p>		

## N623P218194

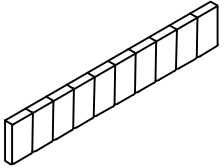

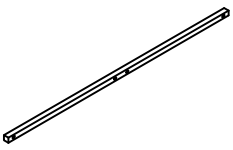
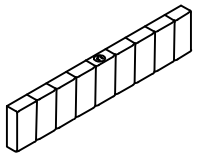

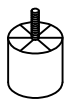





<p>① x1</p>  <p>Top head board</p>	<p>③ x1</p>  <p>Side rail</p>	<p>⑤ x1</p>  <p>Iron side rod</p>
<p>⑧ x1</p>  <p>Head board leg</p>	<p>⑨ x1</p>  <p>Head board leg</p>	<p>⑬ x1</p>  <p>Center support bar</p>

## Hardwareliste+N623P218193

<p>④ x1</p>  <p>Foot board</p>	<p>⑦ x1</p>  <p>Side backrest</p>	<p>⑩ x1</p>  <p>Head board cross bar</p>
<p>⑪ x1</p>  <p>Base head board</p>	<p>⑭ x3</p>  <p>Middle support leg</p>	<p>⑮ x1</p>  <p>Bed legs</p>

# Hardwareliste

## N623P218193

<p>A x1</p>  <p>Allen Key</p>	<p>B x17</p>  <p>M8x40mm</p> <p>Bolts</p>	<p>C x5</p>  <p>Hinge</p>
<p>D x36</p>  <p>M8x16mm</p> <p>Bolts</p>	<p>E x8</p>  <p>M4x25mm</p> <p>Nails</p>	<p>F x2</p>  <p>Three hole iron</p>
<p>G x4</p>  <p>Center support bar fittings</p>	<p>H x1</p>  <p>Power line</p>	<p>I x1</p>  <p>Power adapter</p>
<p>J x1</p>  <p>LED</p>	<p>K x1</p>  <p>Color controller</p>	

**DE:** Vor dem Einbau die Schrauben in die Löcher stecken und festziehen, aber nicht bis 100%, 70% bis 80% anziehen reicht aus. Schließlich, nachdem alle Schrauben installiert sind, ziehen Sie alle Schrauben auf 100%.

Wenn Sie auf diese Probleme stoßen, wie z. B. Fehlausrichtung der Löcher oder Unfähigkeit, bestimmte Teile zu installieren, überprüfen Sie bitte, ob die Schrauben korrekt verwendet werden und passen Sie die Dichtigkeit der Schrauben an.

**UK:** Before installation, insert the screws into the holes and tighten them, but do not tighten them to 100%, 70% to 80% is sufficient. Finally, after all screws are installed, tighten all screws to 100%.

If you encounter these issues, such as if the holes cannot be aligned or some parts cannot be installed, please check if the screws are used correctly and adjust the tightness of the screws.

**FR:** Insérer la vis dans le trou avant la fin de l'assemblage, serrer la vis, mais ne pas serrer à 100%, 70% ~ 80% est correct. Enfin, une fois que toutes les vis sont bien serrées, toutes les vis sont serrées à 100%.

Si vous rencontrez ces problèmes, par exemple si les trous ne sont pas alignés ou si certaines pièces ne peuvent pas être montées, vérifiez que les vis sont utilisées correctement et Ajustez leur serrage.

Attention: Do not tighten the screws before completing the entire installation. If you have any difficulty with the installation process, please feel free to contact us.

### Step 1

Stick the LED J to the bottom of the Top headboard ①.  
 (Kleben Sie die LED J an die Unterseite des oberen Kopfteils ①.)

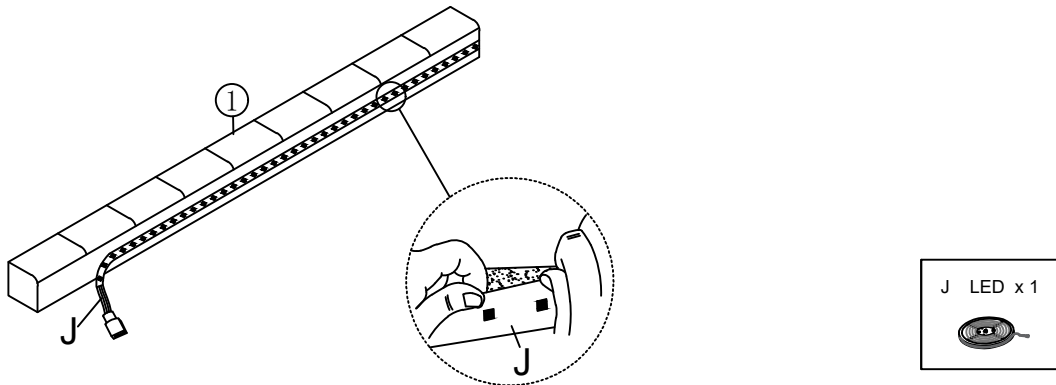

### Step 2

Fix the Headboard leg ⑧ and ⑨ to the Top headboard ① with Three hole iron F and Bolts D by using Allen key A.  
 (Befestigen Sie das Kopfteil-Bein ⑧ und ⑨ am oberen Kopfteil ① mit Dreiloch-Eisen F und Schrauben D mit Inbusschlüssel A.)

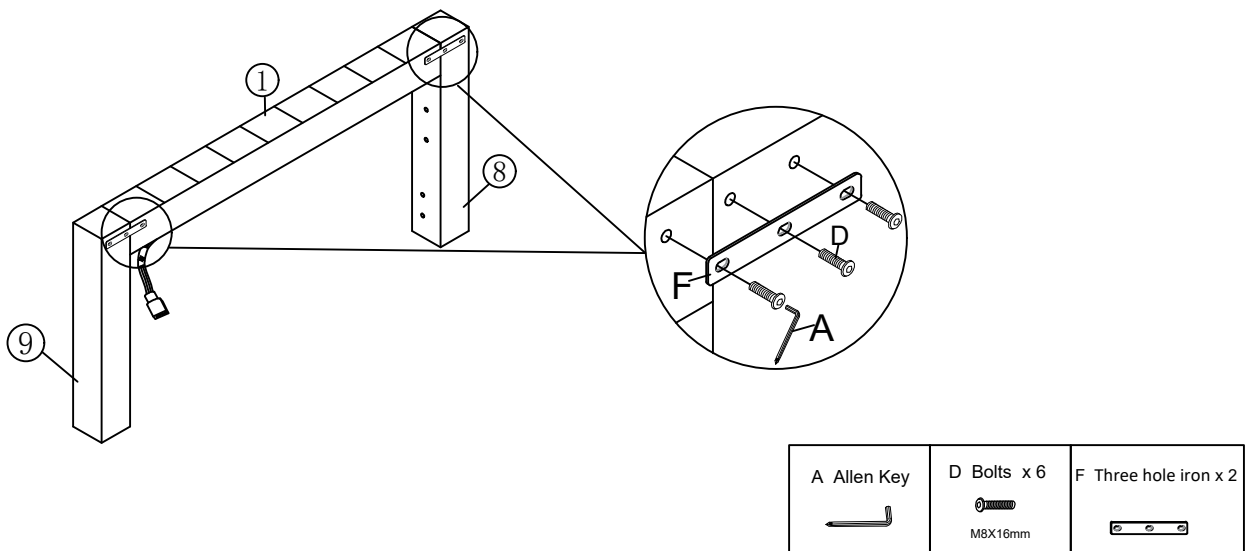

### Step 3

Fix the Base headboard ⑪ to the Head board legs ⑧ and ⑨ with Hinge C and Bolts D by using Allen key A.  
 (Befestigen Sie das Base Kopfteil ⑪ mit Scharnier C und Schrauben D mit Inbusschlüssel A an den Kopfteilbeinen ⑧ und ⑨.)

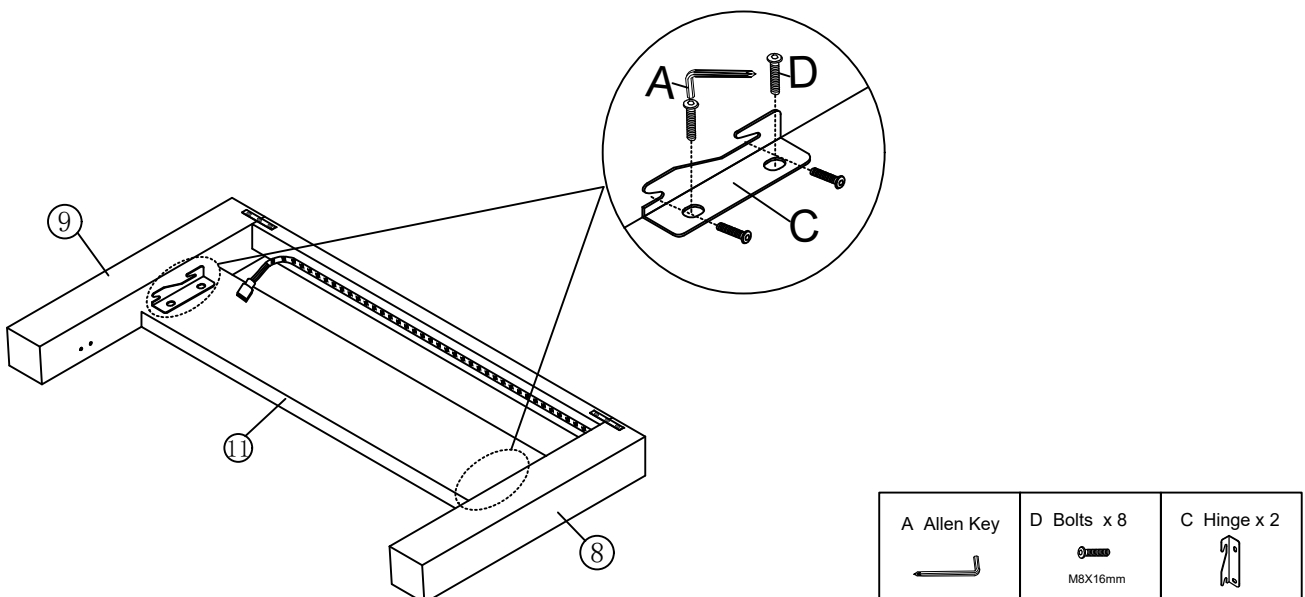

### Step 4

Fix the Back board ⑫ to the Top headboard ①, Base board ⑪, Head board legs ⑧ and ⑨ with Nails E by using Allen key A.  
 (Befestigen Sie das Rückenbrett ⑫ mit Nägeln E und einem Inbusschlüssel A am oberen Kopfteil ①, dem Basisbrett ⑪ sowie den Kopfteilbeinen ⑧ und ⑨.)

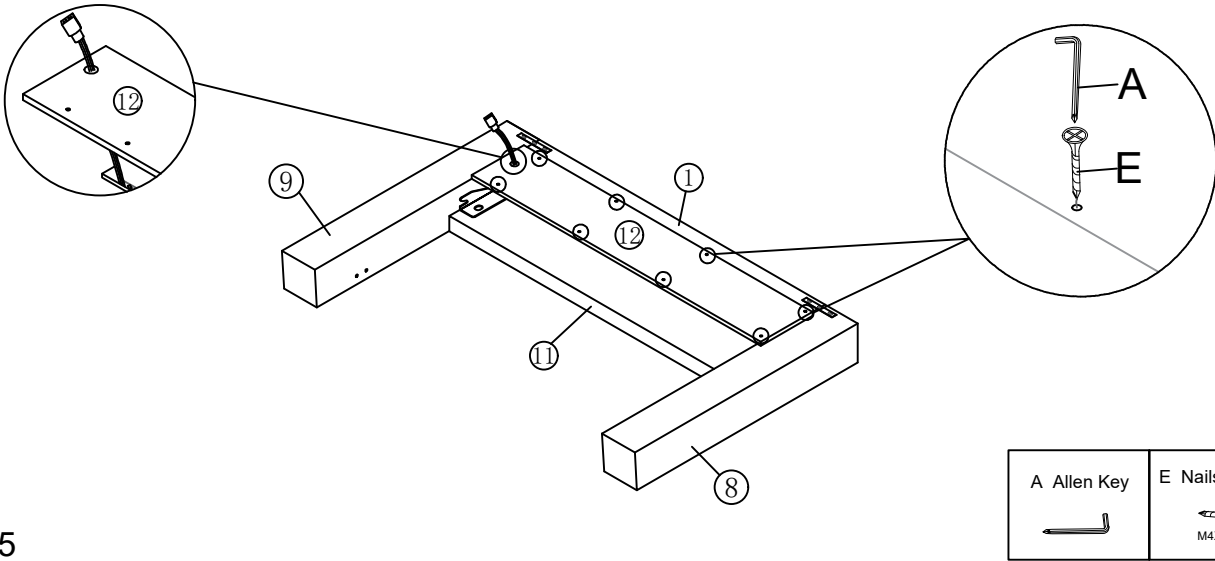

### Step 5

Fix the Backrest ② to the Headboard leg ⑨ with Bolts B by using Allen key A.  
 (Befestigen Sie die Rückenlehne ② mit den Schrauben B und dem Inbusschlüssel A am Kopfteilbein ⑨.)

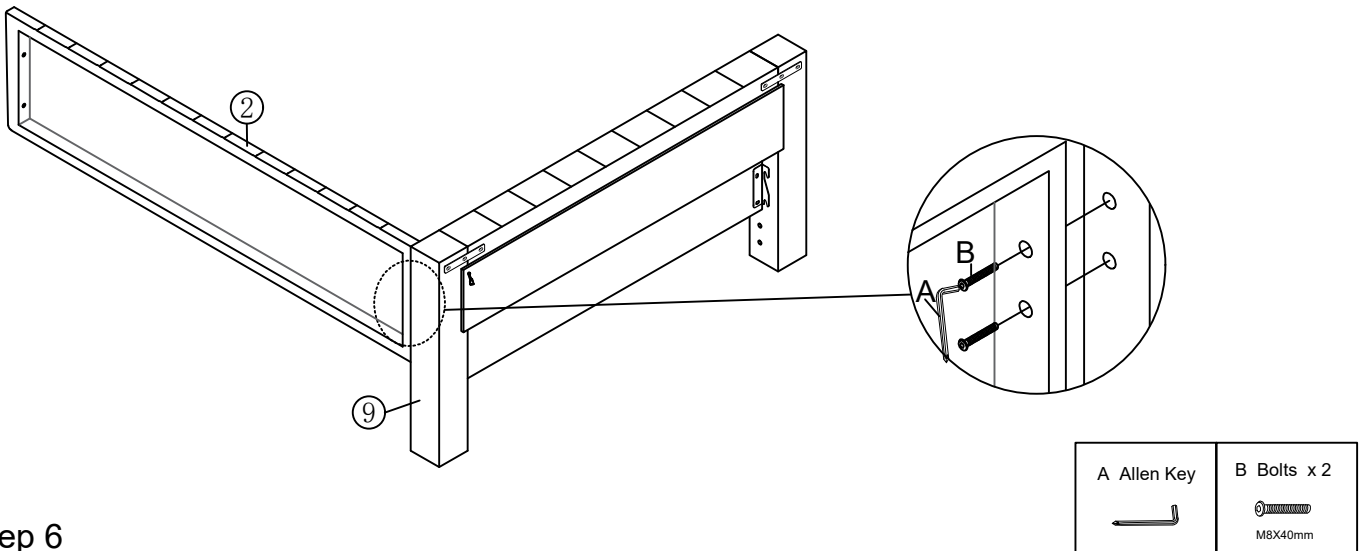

### Step 6

Fix the Side backrest ⑦ to the Backrest ② with Bolts B by using Allen key A.  
 (Befestigen Sie die Seitenrückenlehne ⑦ mit den Schrauben B und dem Inbusschlüssel A an der Rückenlehne ②.)

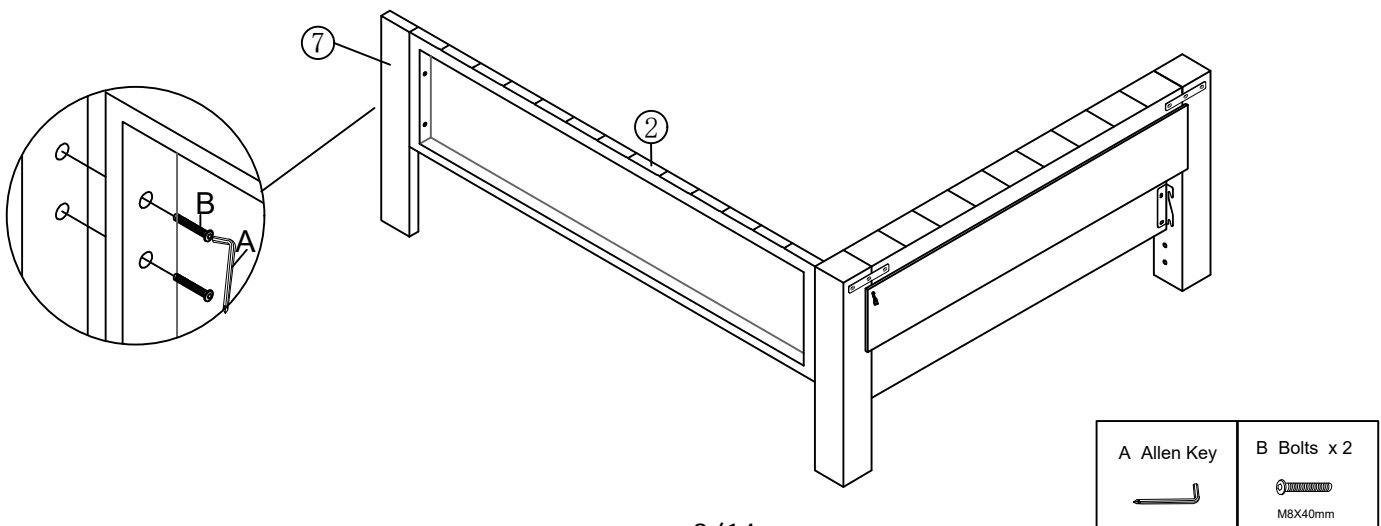



## Step 7

Fix the Center support bar fittings G to the head board leg ⑧ and ⑨ with Bolts D by using Allen key A.

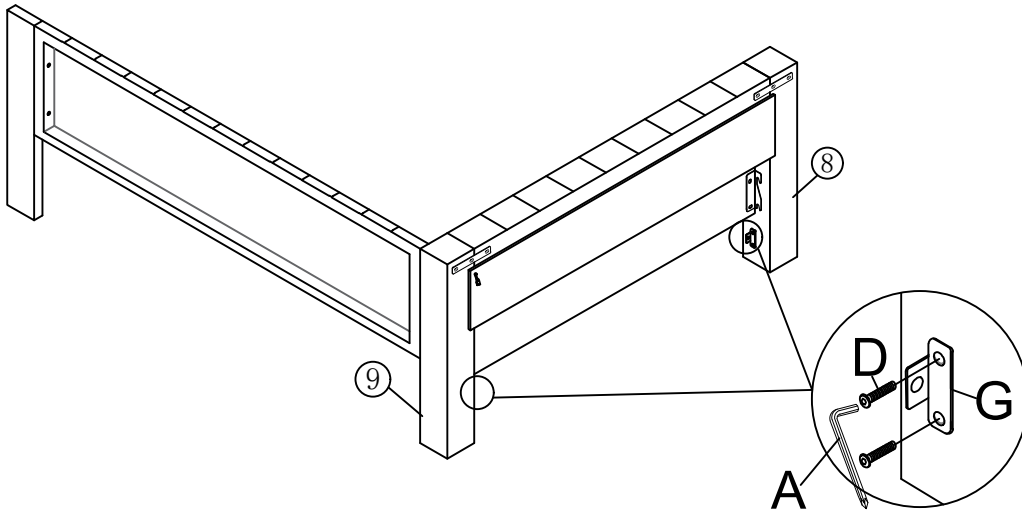
(Befestigen Sie die Beschläge G der mittleren Stützstange mit den Schrauben D und einem Inbusschlüssel A an den Kopfteilbeinen ⑧ und ⑨.)





A Allen Key 	D Bolts x 4 M8X16mm 	G Center support bar fittings X2 
--	---	---

## Step 8

Fix the Headboard cross bar ⑩ to the Head board leg ⑧ and ⑨ with Bolts B by using Allen key A.

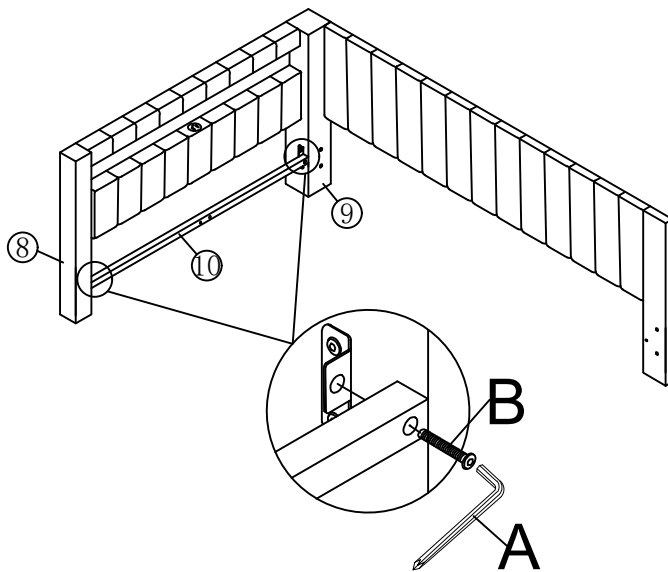
(Befestigen Sie die Kopfteil-Querstange ⑩ mit den Schrauben B und einem Inbusschlüssel A an den Kopfteil-Beinen ⑧ und ⑨.)







A Allen Key 	B Bolts x 2 M8X40mm 
--	---

## Step 9

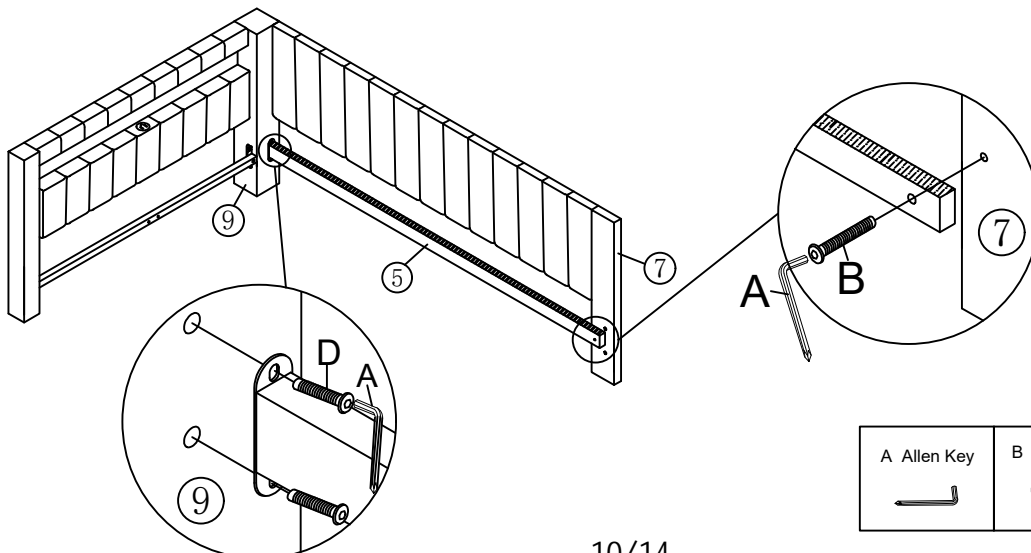
Fix the Iron side rod ⑤ to the head board ⑨ and Side backrest ⑦ with Bolts B and Bolts D by using Allen key A.

(Befestigen Sie die Eisenseitenstange ⑤ mit den Schrauben B und D mithilfe des Inbusschlüssels A am Kopfteil ⑨ und an der Seitenrückenlehne ⑦.)





A Allen Key 	B Bolts x 1 M8X40mm 	D Bolts x 2 M8X16mm 
--	---	---

## Step 10

Fix the center support bar (6) to Side rail (3) with Bolts B by using Allen key A.

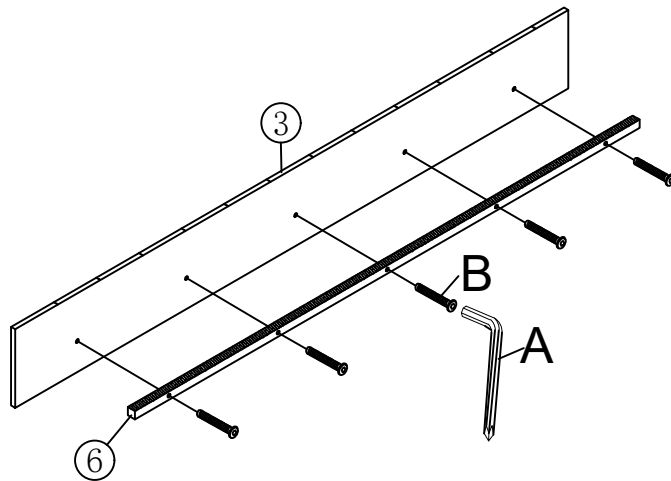
(Befestigen Sie die mittlere Stützstange (6) mit den Schrauben B und einem Inbusschlüssel A an der Seitenschiene (3).)



A Allen Key	B Bolts x 5 M8x40mm
	

## Step 11

Fix the leg (15) to the Footboard (4).

(Befestigen Sie das Bein (15) am Trittbrett (4).)

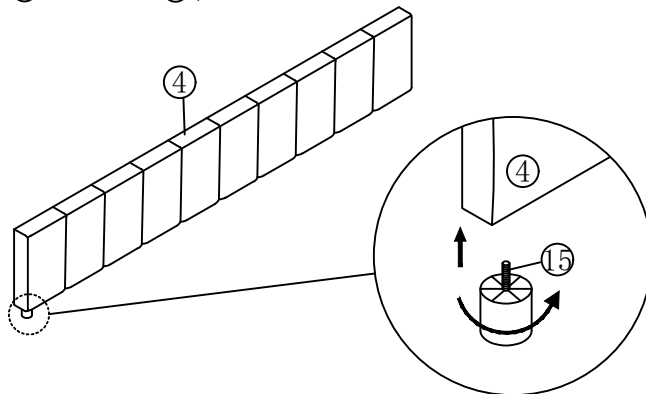



## Step 12

Fix the Side rail (3), Foot board (4), Head board leg (8) and Side backrest (7) together with Hinge C and Bolts D by using Allen key A.

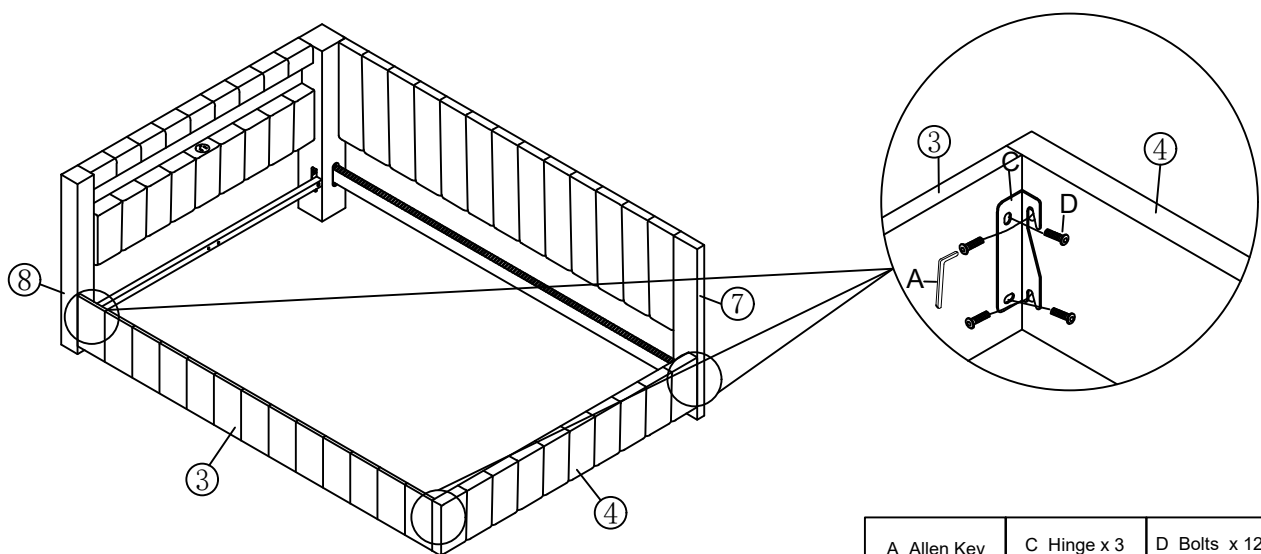
(Befestigen Sie die Seitenschiene (3), das Fußteil (4), das Kopfteilbein (8) und die Seitenrückenlehne (7) zusammen mit dem Scharnier C und den Schrauben D mithilfe des Inbusschlüssels A.)





A Allen Key	C Hinge x 3	D Bolts x 12 M8x16mm
		

## Step 13

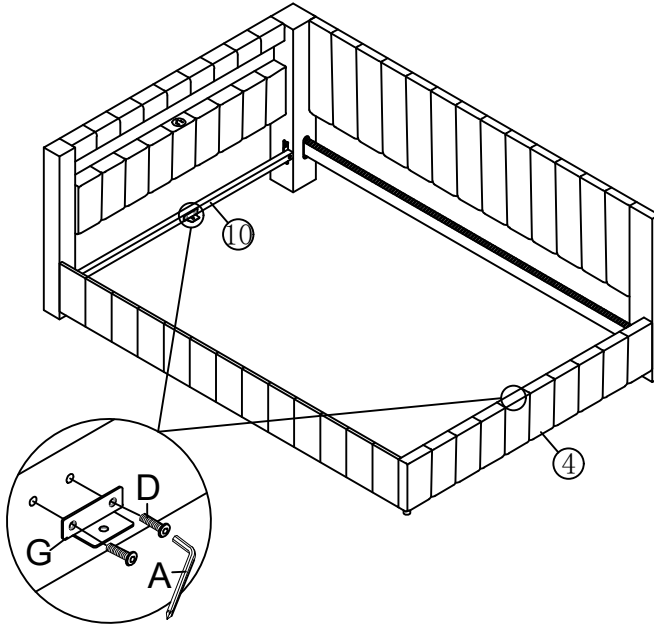
Fix the Center support bar fittings G to the Headboard cross bar ⑩ and foot board ④ with Bolts D by using Allen key A.  
 (Befestigen Sie die mittleren Stützstangenbeschläge G mit den Schrauben D und dem Inbusschlüssel A an der Querstange ⑩ des Kopfteils und dem Fußteil ④.)





A Allen Key 	D Bolts x 4  M8X16mm	G Center support bar fittings X2 
--	---	---

## Step 14

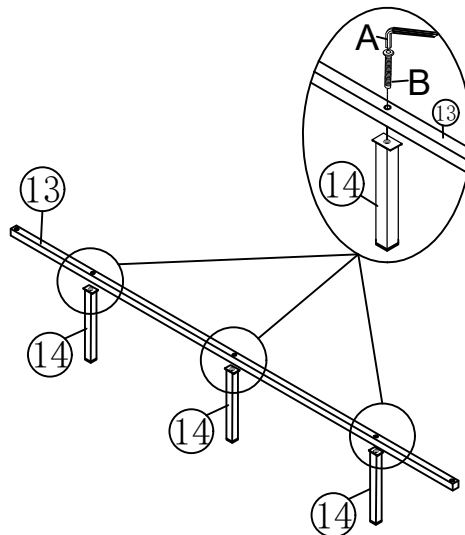
Fix the middle support leg ⑭ to the center support bar ⑬ with Bolts B by using Allen key A.  
 (Befestigen Sie das mittlere Stützbein ⑭ mit den Schrauben B und einem Inbusschlüssel A an der mittleren Stützstange ⑬.)





A Allen Key 	B Bolts x 3  M8X40mm
--	---

## Step 15

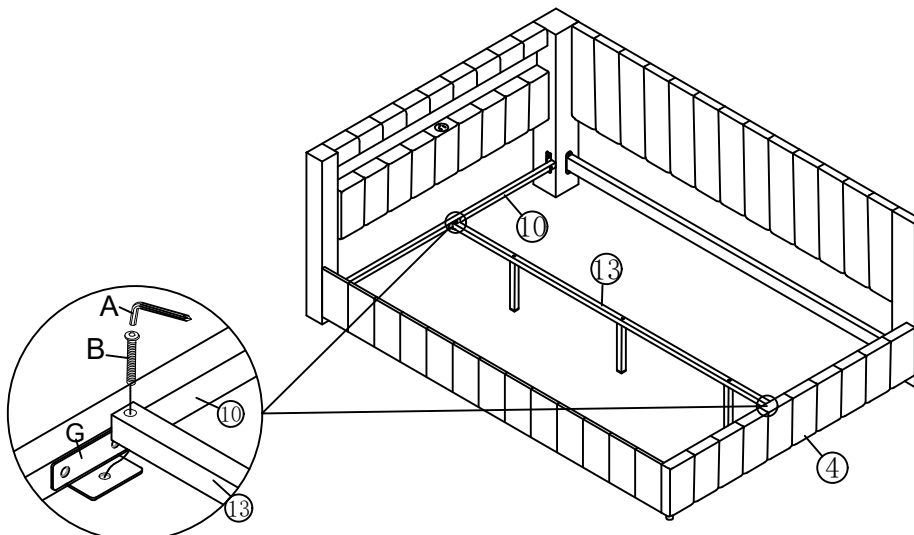
Fix the Center support bar ⑬ to the headboard cross bar ⑩ and foot board ④ with Bolts B by using Allen key A.  
 (Befestigen Sie die mittlere Stützstange ⑬ mit den Schrauben B und einem Inbusschlüssel A an der Kopfteil-Querstange ⑩ und dem Fußteil ④.)



A Allen Key 	B Bolts x 2  M8X40mm
--	---

## Step 16

Fix the slats ⑬ to the side support bar ⑥ and Iron side rod ⑤.

(Befestigen Sie die Lamellen 16 an der seitlichen Stützstange ⑥ und der seitlichen Eisenstange ⑤.)

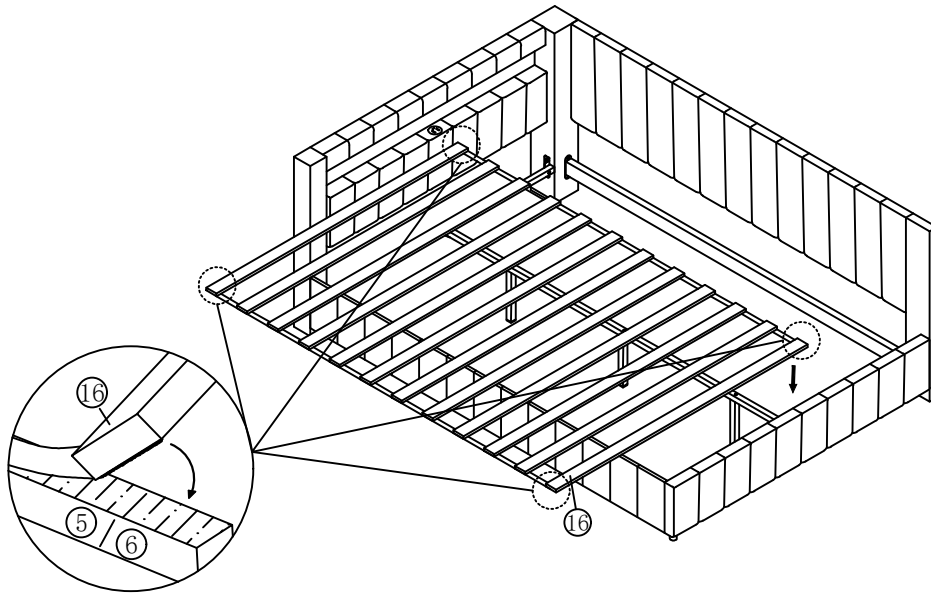

## Step 17

At first, connect the LED J to the Color controller K, please notice that → ←.

At second, connect one end of the Power line H to the Color controller K.

At third, connect the usb line to the another end of Power line H.

Finally, connect the Power line H to the Power adapter I, then connect the power and enjoy your bed.

(Schließen Sie zuerst die LED J an den Farbcontroller K an. Beachten Sie dies → ←.

Schließen Sie dann ein Ende des Stromkabels H an den Farbcontroller K an.

Schließen Sie dann das USB-Kabel an das andere Ende des Stromkabels H an.

Schließen Sie zum Schluss das Stromkabel H an das Netzteil I an, schließen Sie dann den Strom an und genießen Sie Ihr Bett.)

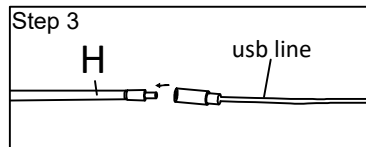
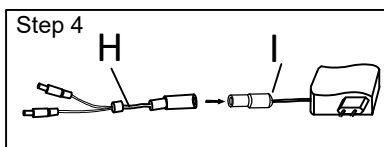
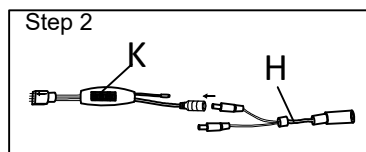
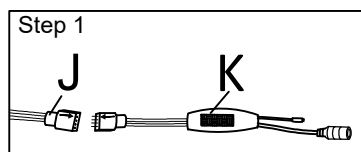
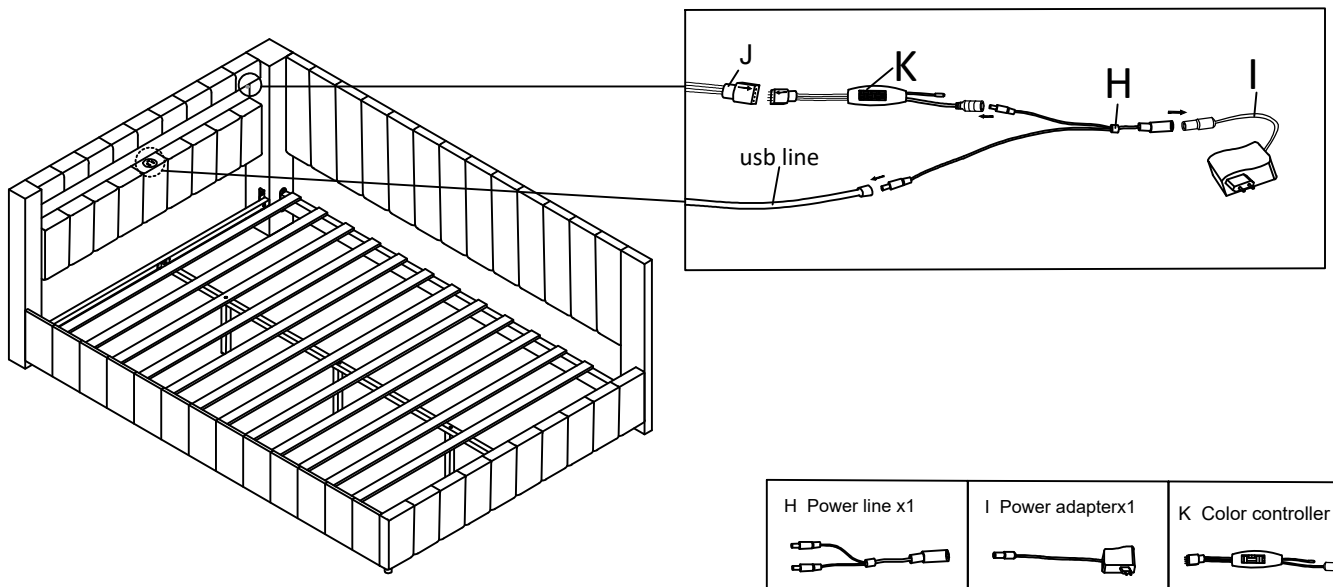

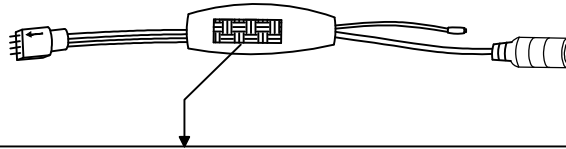

**NOTICE:**

You can scan the QR code here and download an app that can control the color of the light strip like a remote control. When your phone plays music through the app, the color of the light strip will also change according to the strength of the music.

**HINWEIS:**

Sie können hier den QR-Code scannen und eine App herunterladen, die die Farbe des Lichtstreifens wie eine Fernbedienung steuern kann. Wenn Ihr Telefon Musik über die App abspielt, ändert sich die Farbe des Lichtstreifens auch entsprechend der Stärke der Musik.

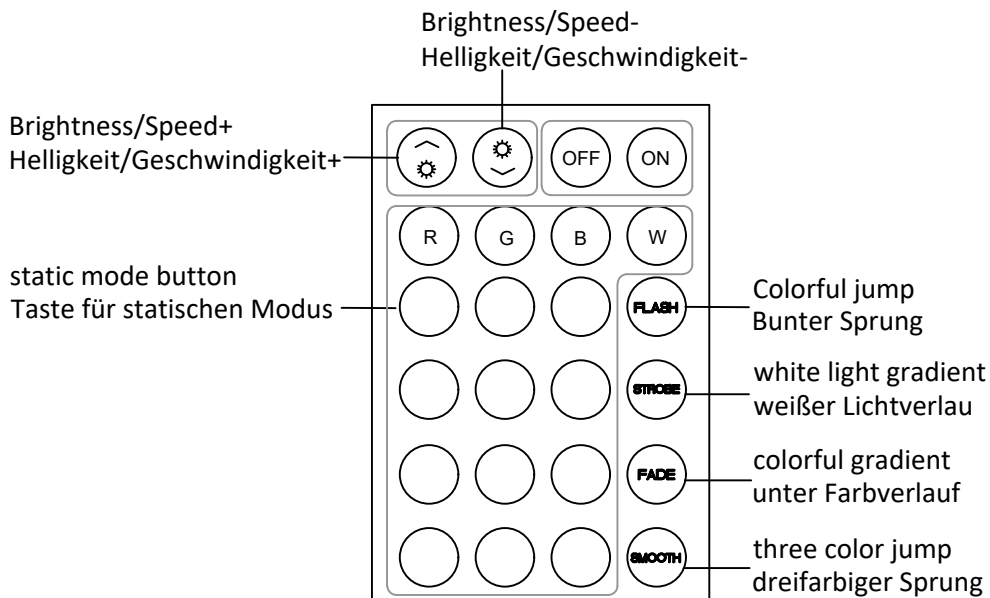

**NOTICE:**

When you use the remote control board to control the color of the light, Please remove the clear plastic card first, then please be sure to point the remote control at the color controller .

**HINWEIS:**

Wenn Sie die Fernbedienungsplatte verwenden, um die Farbe des Lichts zu steuern, entfernen Sie bitte zuerst die durchsichtige Plastikkarte und achten Sie dann darauf, die Fernbedienung auf den Farbegler zu richten.

# Verification of Compliance

Verification No.:	MK23020083-P01C01
Name and address of Applicant:	<b>Shenzhen Hongzhengyu Technology Co., LTD</b> Shenzhen baoan district rock street industrial science and technology industrial park of 2 Haitian lanyu 3 5 floor of A
Name and address of Manufacturer:	<b>Shenzhen Hongzhengyu Technology Co., LTD</b> Shenzhen baoan district rock street industrial science and technology industrial park of 2 Haitian lanyu 3 5 floor of A
Product name:	<b>Lamp strip</b> HZY-2835-120D-12V, HZY-2835-30D-5V, HZY-2835-60D-5V, HZY-2835-120D-5V, HZY-2835-60D-12V, HZY-2835-60D-24V, HZY-2835-120D-24V, HZY-2835RGB-60D-5V, HZY-2835RGB-60D-12V, HZY-5050-30D-5V, HZY-5050-60D-5V, HZY-5050-30D-12V, HZY-5050-60D-12V, HZY-5050-60D-24V, HZY-5050RGB-30D-5V, HZY-5050RGB-60D-5V, HZY-5050RGB-30D-12V, HZY-5050RGB-60D-12V, HZY-5050RGB-60D-24V
Product model(s):	
Product trademark:	N/A

This verification confirms that the product meets the requirements of the following standard.

The conformity was demonstrated based on following standard(s) listed by European Commission as harmonized with Directive RoHS 2.0 Directive (EU) 2015/863 and (EU)2017/2102 amending Annex II to Directive 2011/65/EU

IEC 62321-1:2013	IEC 62321-3-1:2013
IEC 62321-4:2013/AMD1:2017	IEC 62321-5:2013
IEC 62321-6:2015	IEC 62321-7-1:2015
IEC 62321-7-2:2017	IEC 62321-8:2017

*The verification has been carried out in accordance with individual rules and conditions agreed with the applicant. Evaluation has been carried out in accordance with:*

Test report(s) No.:	MK23020083-P01C01
Test conducted by:	TMC Testing Services (Shenzhen) Co., Ltd.
Verification issue date:	February 25, 2023

#### Notes:

*This verification refers to the above mentioned product and its conformity in regards of above mentioned standard(s) was proven on test sample.*

*This verification does not imply meeting all essential requirements, assessment of the series-production or any other restricted Notified Bodies conformity assessment procedure appropriate for the product.*

*This verification holder shall use this verification in connection to verification of conformity and technical data relevant for the product the verification was issued.*

#### **TMC Testing Services (Shenzhen) Co., Ltd.**

t:86-755-86642861 cert@tmc-lab.com www.tmc-lab.com

1st Floor, Block A1, Zone A, Xinshidai Gongrong Industrial Park, No. 2, Shihuan Road, Shiyuan Street, Baoan District, Shenzhen, China



**Lab Director**  
Vivian Jiang



# Verification of Compliance

Verification No.: MK24070005P01-E01

Name and address of Applicant: **Shenzhen Aoli Optoelectronics Co., Ltd**  
5th Floor, Building 3, Haitian Lanyu Science and Technology Park,  
Shilong Community, Shiyan Street, Bao'an District, Shenzhen

Name and address of Manufacturer: **Shenzhen Aoli Optoelectronics Co., Ltd**  
5th Floor, Building 3, Haitian Lanyu Science and Technology Park,  
Shilong Community, Shiyan Street, Bao'an District, Shenzhen

Product name: **Embedded USB port**

Rated: Input:12V<sup>~</sup>  
Output:5V<sup>~</sup>

Product model(s): 12vA+c, 5vA+c

Product trademark: N/A

This verification confirms that the product meets the requirements of the following standard.  
The conformity was demonstrated based on following standard(s) listed by European Commission as harmonized with EMC Directive 2014/30/EU

EN 55032:2015+A11:2020

EN 55035:2017+A11:2020

*The verification has been carried out in accordance with individual rules and conditions agreed with the applicant. Evaluation has been carried out in accordance with:*

Test report(s) No.: MK24070005P01-E01

Test conducted by: TMC Testing Services (Shenzhen) Co., Ltd.

Verification issue date: July 11, 2024

**Notes:**

*This verification refers to the above mentioned product and its conformity in regards of above mentioned standard(s) was proven on test sample.*

*This verification does not imply meeting all essential requirements, assessment of the series-production or any other restricted Notified Bodies conformity assessment procedure appropriate for the product.*

*This verification holder shall use this verification in connection to verification of conformity and technical data relevant for the product the verification was issued.*

**TMC Testing Services (Shenzhen) Co., Ltd.**

t:86-755-86642861 cert@tmc-lab.com www.tmc-lab.com

1st Floor, Block A1, Zone A, Xinshidai Gongrong Industrial Park, No. 2, Shihuan Road, Shiyan Street, Baoan District, Shenzhen, China



**Lab Director**  
Vivian Jiang

