

GER-YY800

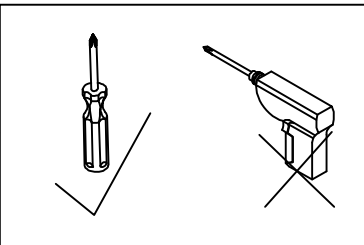
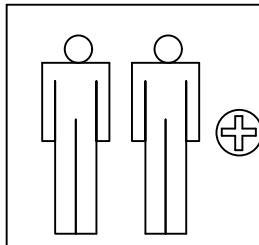
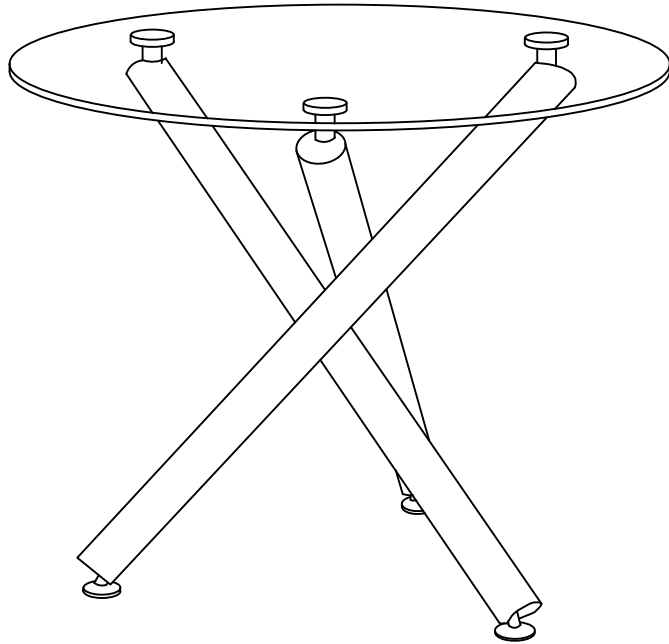

EN_Important Notes

1. Please inspect all components carefully before assembly.
2. During assembly, place the product on a soft, smooth surface (e.g., a carpet) to prevent scratching the parts.
3. Follow the assembly instructions in the correct sequence.
4. Do not fully tighten any screws until the product is completely assembled.
5. Returns are only accepted in the original packaging.
(*Assembled products are not eligible for return).

FR_Remarques importantes

1. Veuillez inspecter soigneusement tous les composants avant l'assemblage.
2. Lors de l'assemblage, placez le produit sur une surface lisse et molle (comme un tapis) pour éviter de rayer les pièces.
3. Suivez les instructions d'assemblage dans l'ordre indiqué.
4. Ne serrez aucune vis complètement avant que le produit ne soit entièrement assemblé.
5. Les retours ne sont acceptés que dans l'emballage d'origine.
(*Les produits assemblés ne peuvent pas être retournés).

ES_Notas importantes

1. Inspeccione todos los componentes minuciosamente antes del montaje.
2. Durante el montaje, coloque el producto sobre una superficie lisa y blanda (por ejemplo, una alfombra) para evitar que se rayen las piezas.
3. Siga las instrucciones de montaje en el orden correcto.
4. No apriete por completo ningún tornillo hasta que el producto esté completamente montado.
5. Las devoluciones solo se aceptarán en el embalaje original.
(*No se admiten devoluciones de productos ya montados).









DE_Wichtige Hinweise

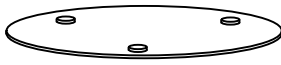
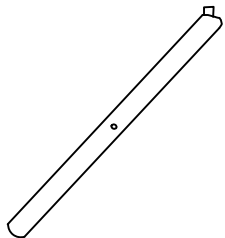

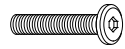
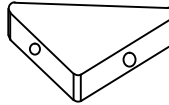
1. Bitte überprüfen Sie vor der Montage alle Komponenten sorgfältig..
2. Stellen Sie das Produkt während der Montage auf eine glatte, weiche Oberfläche (z. B. einen Teppich), um Kratzer an den Teilen zu vermeiden.
3. Befolgen Sie die Montageanleitung in der vorgegebenen Reihenfolge.
4. Ziehen Sie die Schrauben erst vollständig fest, wenn das Produkt vollständig montiert ist.
5. Rücksendungen sind nur in der Originalverpackung möglich.
(*Montierte Produkte können nicht zurückgegeben werden).

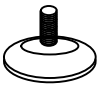
IT_Note importanti

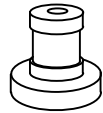
1. Prima dell'assemblaggio, ispezionate attentamente tutti i componenti.
2. Durante l'assemblaggio, posizionate il prodotto su una superficie liscia e morbida (ad esempio, un tappeto) per evitare di graffiare le parti.
3. Seguire le istruzioni di assemblaggio nell'ordine corretto.
4. Non serrare completamente le viti prima che il prodotto sia completamente assemblato.
5. Le resi sono accettati solo nella confezione originale.
(*I prodotti assemblati non possono essere restituiti).



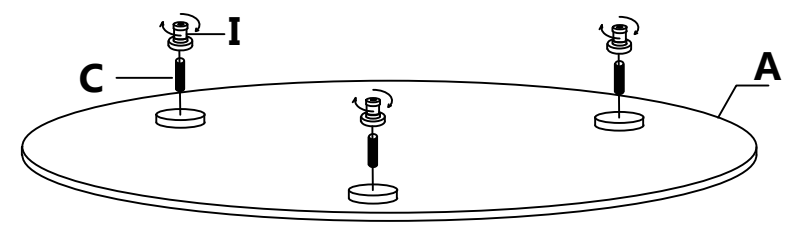

1

A x1 	B x3 	C x3 
D x3 	E x1 	F x3 
G x3 	H x1 	I x3 
J x1 		

A		x1
C		x3
I		x3



2

H		x1	B		x3
D		x3	E		x1

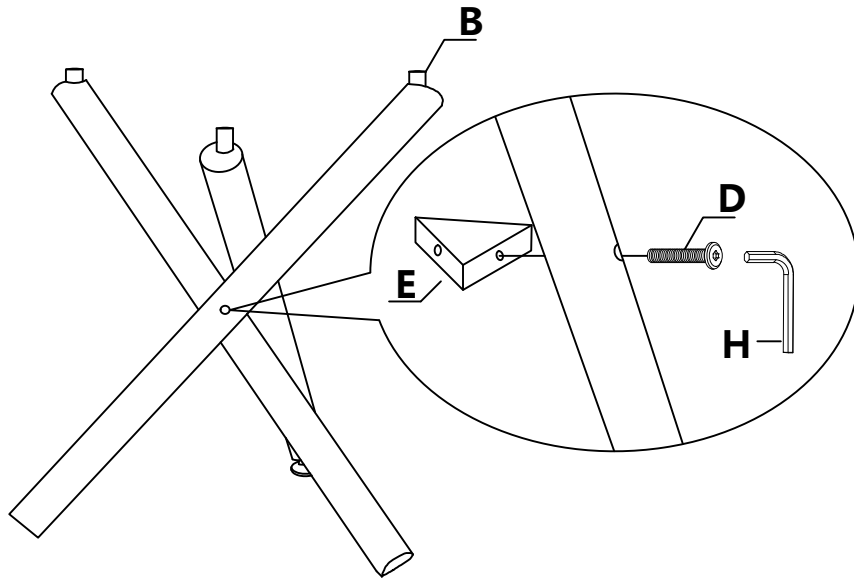

EN_Note: After assembling the legs, please ensure that the three top holes on the legs are all on the inside. This will allow for proper alignment during the installation of the glass top in the next step.



FR_Remarque : après avoir assemblé les pieds, assurez-vous que les 3 trous supérieurs des pieds se trouvent tous à l'intérieur afin qu'ils puissent être adaptés au plateau en verre lors de l'étape suivante.

ES_Nota: Después de montar la parte de las patas, asegúrese de que los tres orificios superiores de las patas estén todos en el interior para que encajen en el montaje de la parte superior de cristal en el siguiente paso.

DE_Hinweis: Nach der Montage der Beine stellen Sie bitte sicher, dass sich die drei oberen Löcher der Beine alle auf der Innenseite befinden, damit sie für die Montage der Glasplatte im nächsten Schritt geeignet sind.

IT_Nota: dopo aver assemblato le gambe, assicurarsi che i 3 fori superiori delle gambe siano tutti all'interno, in modo da facilitare il montaggio del piano in vetro nella fase successiva.

3

F		x3	G		x3
J		x1			

