

ASSEMBLY INSTRUCTION

SKU CODE: (N623P357270-71-72-73-74)

ANLEITUNG

ARTIKELNUMMER: (N623P357270-71-72-73-74)

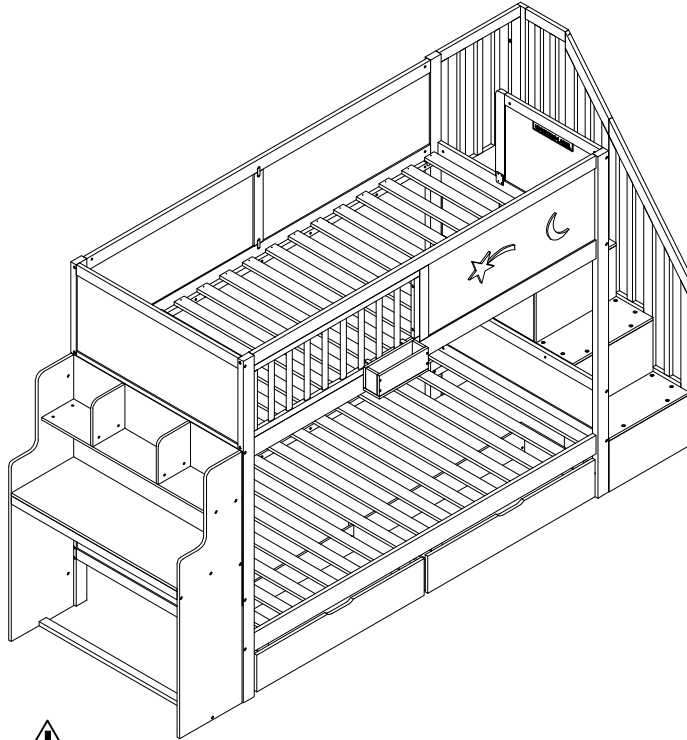

F



- Contrôlez le contenu de votre colis avant de procéder au montage.
- Ne détériorez pas l'emballage, il vous sera très utile pour protéger les éléments des coups et rayures pendant le montage.
- Assemblez ensuite le meuble en suivant l'ordre défini par la numérotation.
- En cas de problème contactez notre service Après-Vente.
- Du fait de son confinement dans le carton après emballage, il est possible qu'au déballage et au montage votre produit dégage dans l'air des odeurs de vernis, plus ou moins prononcées. Afin que ces odeurs ne vous incommode pas, nous vous conseillons de disposer votre produit dans une pièce convenablement et régulièrement aérée, en ouvrant complètement les portes et en déposant les tiroirs à côté du meuble, jusqu'à disparition de ces odeurs.

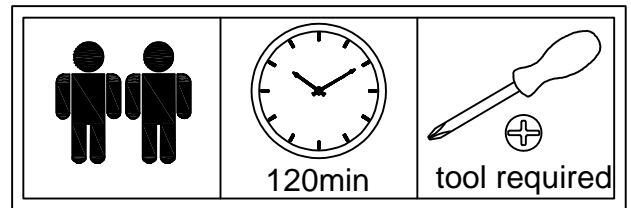

GB



- Check the content of your parcel before assembling.
- Do not throw away the packing which could be very useful to protect the panels from knocks and scratches when assembling.
- Next assemble the article following the order of the numbers indicated.
- Should any problems arise, please contact our After Sales Service.
- You may notice a smell of varnish when you unpack your item, due to its having been stored in a box since its packaging. In order to avoid any inconvenience that may be caused by such odours, we recommend that you place the item in a well ventilated room, opening all doors, and removing the drawers from the cabinet, until any such odours have dissipated.

P



- Confira o conteúdo da sua encomenda antes de iniciar a montagem.
- Não danifique a embalagem, poderá ser-lhe útil para proteger os elementos de golpes ou riscos durante a montagem.
- Proceda à montagem do móvel seguindo a ordem definida pela numeração.
- Para qualquer esclarecimento, contacte os nossos serviços através do telefone.
- Devido ao seu encerramento na caixa de cartão após o acondicionamento, é possível que, no momento da desembalagem e montagem do produto, este lance para o ar um cheiro a verniz, mais ou menos intenso. Para que este cheiro não o incomode, aconselhamos-lhe a colocar o produto num compartimento adequado e regularmente arejado, deixando as portas totalmente abertas e colocando as gavetas ao lado do móvel, até que o referido cheiro desapareça.

S



- Controlar el contenido de su embalaje antes de proceder al montaje.
- No deteriorar el paquete, que le será muy útil para proteger los elementos de golpes y rozaduras durante el montaje.
- Acoplar de seguida el mueble, siguiendo la orden definida por la numeración.
- Si tiene problemas, contactar nuestro servicio postventa.
- Dado que el mueble ha permanecido encerrado en la caja de cartón desde el momento de su acondicionamiento, es posible que al desembalarlo desprenda a la atmósfera un olor a barniz más o menos pronunciado. Con el fin de evitar que esos olores sean para usted una incomodidad, le aconsejamos dejar el producto en un lugar adecuado y regularmente aireado; abrir por completo las puertas, retirar los cajones y dejarlos aireándose junto al mueble, hasta que tales olores hayan desaparecido.

G



- Vor Montage den Inhalt Ihres Päckchens kontrollieren.
- Die Verpackung nicht zerstören, sie wird Ihnen nützlich sein, um die Teile bei der Montage vor Stößen und Kratzern zu schützen.
- Das Möbel dann in der Reihenfolge der Nummerierung zusammenbauen.
- Im Problemfall Ihren Kundendienst anrufen.
- Da das Möbelstück eine gewisse Zeit lang eng verpackt war, ist nicht auszuschließen, dass sich beim Auspacken und der Montage ein mehr oder minder starker Lackgeruch entwickelt. Damit der Lackgeruch Sie nicht stört, empfehlen wir Ihnen, Ihren Einrichtungsgegenstand in einen gut und regelmäßig gelüfteten Raum zu stellen, die Schubladen herauszunehmen und die Türen ganz zu öffnen, bis sich der Lackgeruch vollständig verflüchtigt hat.

I



- Verificare il contenuto della confezione prima del montaggio.
- Non eliminare l'imballo che potrà essere utilizzato per proteggere il prodotto dai danni durante il montaggio.
- Montare l'articolo seguendo l'ordine di numerazione.
- In caso di necessità contattare il nostro servizio post-vendita.
- Per il fatto di essere rimasto chiuso nel cartone dopo l'imballaggio, è possibile che il mobile una volta liberato dal cartone e durante il montaggio sprigioni nell'aria odori di vernice più o meno forti. Affinché questi odori non Le creino fastidio, raccomandiamo di collocare il prodotto in un locale adeguatamente e regolarmente aerato, aprendo completamente le porte e depositando i cassetti accanto al mobile fino alla scomparsa degli odori.

D



- De inhoud van uw pakket controleren alvorens met de montage te beginnen.
- De verpakking niet beschadigen, deze kan heel handig zijn om de onderdelen te beschermen tegen schokken en krassen tijdens de montage.
- Zet vervolgens het meubel in elkaar in de volgorde die is bepaald in de nummering.
- Neem bij problemen contact op met onze klantenservice.
- Het is mogelijk dat zich bij het uitpakken en in elkaar zetten van uw product een min of meer uitgesproken laklucht verspreidt. Om te voorkomen dat u last heeft van deze lucht, raden we u aan om uw product in een voldoende en regelmatig geventileerde ruimte neer te zetten. Doe daarbij de deurtjes helemaal open en zet de laden naast het meubel neer totdat deze lucht is verdwenen.

ASSEMBLY INSTRUCTION - ANLEITUNG

EN - IMPORTANT! KEEP FOR FUTURE REFERENCE: READ CAREFULLY

- To be assembled by an adult. Assembly must be checked by an adult before use
- **WARNING!** keep all screws, small parts and plastic bags out of the reach of children
- Properly identify all parts before assembling
- Never use your item if any of its parts are broken or missing
- Should any problems arise, please contact our After Sales Service
- Manufacturer's instructions shall be followed at all times
- Care: clean with a soft, dry cloth. In case of larger stains, carefully rub with a slightly damp, non-abrasive sponge
- Do not jump on the bed

FR - IMPORTANT! CONSERVER POUR CONSULTATION ULTERIEURE: LIRE ATTENTIVEMENT

- A monter par un adulte. Un adulte doit vérifier le bon assemblage avant l'emploi
- **ATTENTION!** tenir les vis et petits éléments et sachets hors de portée des enfants
- Bien identifier les éléments avant de commencer le montage
- Ne pas utiliser votre article lorsque l'un de ses éléments est cassé ou manquant
- En cas de problème contactez notre service après-vente
- Toujours suivre les instructions du fabricant
- Entretien: nettoyer avec un chiffon doux et sec. En cas de taches plus grosses, frottez soigneusement avec une éponge légèrement humide et non abrasive
- Ne pas sauter sur le lit

PT - IMPORTANTE! GARDE PARA CONSULTA POSTERIOR: LER ESTAS INSTRUÇÕES CUIDADOSAMENTE

- A ser montado por um adulto. Um adulto deve verificar a boa montagem antes da utilização
- **Atenção!** mantenha os parafusos, acessórios pequenos e saco de plástico fora do alcance das crianças
- Identifique bem os acessórios antes de começar a montagem
- Não utilizar o artigo se um dos elementos está em falta ou danificado
- Para qualquer esclarecimento, contacte os nossos serviços através do telefone
- As instruções do fabricante devem ser sempre cumpridas
- **Manutenção:** limpe com um pano macio e seco. Em caso de manchas maiores, esfregue cuidadosamente com uma esponja ligeiramente húmida e não abrasiva
- Não salte na cama

ES - IMPORTANTE! CONSERVAR PARA FUTURAS CONSULTAS: LEER DETENIDAMENTE

- A montar por un adulto. Un adulto debe comprobar el buen montaje antes de la utilización
- **¡ADVERTENCIA!** mantener los tornillos, los pequeños elementos y bolsitas fuera del alcance de los niños
- Identificar debidamente los elementos antes de empezar el montaje
- No utilizar este artículo si uno de los elementos falta o esta roto
- Si tiene problemas, contactar nuestro servicio postventa
- Deben seguirse siempre las instrucciones del fabricante Cuidados: limpiar con un paño suave y seco. En caso de manchas grandes, frotar con cuidado utilizando una esponja húmeda no abrasiva
- No saltar sobre la cama

DE - WICHTIG! FÜR SPÄTERE BEZUGNAHME AUFBEWAHREN: SORGFÄLTIG LESEN

- Von einem Erwachsenen zu montieren. Die korrekte Montage muss vor Gebrauch von einem Erwachsenen geprüft werden
- **Achtung!** die Schrauben und kleinen Teile ausserhalb der Reichweite von Kindern lagern
- Vor Montagebeginn alle Teile identifizieren
- Ihren Artikel nicht benutzen, wenn eines seiner Bestandteile beschädigt ist oder fehlt
- Im Problemfall Ihren Kundendienst anrufen
- Stets die Herstelleranweisungen beachten
- **Wartung:** Mit einem weichen, trockenen Tuch reinigen. Bei größeren Flecken vorsichtig mit einem leicht feuchten, nicht scheuernden Schwamm abreiben
- Nicht auf dem Bett springen

IT - IMPORTANTE! CONSERVARE QUESTE INFORMAZIONI PER ULTERIORI CONSULTAZIONI: LEGGI ATTENTAMENTE

- Il montaggio deve essere eseguito da un adulto. Un adulto dovrà verificare il corretto montaggio prima dell'uso
- **ATTENZIONE!** tenere le viti ed i componenti di piccole dimensioni lontano dalla portata dei bambini
- Controllare i pezzi prima del montaggio
- L'articolo non deve essere utilizzato in caso di elementi mancanti o danneggiati
- In caso di necessità contattare il nostro servizio post-vendita
- Seguire sempre le istruzioni del costruttore
- **Manutenzione:** pulire con un panno morbido e asciutto. Per le macchine più grandi, strofinare accuratamente con una spugna leggermente umida e non abrasiva
- Non saltare sul letto

NL - BELANGRIJK! BEWAAR VOOR LATERE RAADPLEGING: LEES AANDACHTIG

- Moet door een volwassene worden gemonteerd. Voor gebruik moet een volwassene controleren dat het product goed in elkaar is gezet
- **WAARSCHUWING!** schroeven en kleine elementen en zakjes buiten bereik van kinderen houden
- De elementen goed identificeren alvorens met de montage te beginnen
- Uw artikel niet gebruiken wanneer een van de onderdelen kapot is of ontbreekt
- Neem bij problemen contact op met onze klantenservice
- Volg altijd de instructies van de fabrikant
- **Onderhoud:** maak schoon met een zachte en droge doek. In geval van grotere vlekken, veeg voorzichtig schoon met een licht bevochtigde en niet-schurende spons
- Niet springen op het bed

ASSEMBLY INSTRUCTION - ANLEITUNG

EN - IMPORTANT - READ CAREFULLY - KEEP FOR FUTURE REFERENCE

- EN 747-1/2:2024
- WARNING: high beds and the upper bed of bunk beds are not suitable for children under six years due to the risk of injury from falls
- WARNING: if they are not used properly, bunk beds and elevated bed can cause serious injury hazards by strangulation. Never hang or tie to parts of the bed elements that are not designed to be used with that bed. These elements include among other things the ropes, strings, hooks, harnesses, belts and bags
- WARNING: children can get trapped between the bed and a wall, a part of a reclined roof, the ceiling, close-by furniture (for example, closets) among others. To avoid any serious injury hazard, the distance between the top safety barrier and the adjacent elements shall not exceed 75mm or shall be more than 230mm
- WARNING: Do not use the bunk beds or elevated bed when a part of the frame is missing or broken
- Manufacturer's instructions shall be followed at all times
- It is necessary to ventilate the room to maintain a low humidity level in order to prevent mould from developing in the bed and around it
- All assembly fittings should always be tightened properly and that fittings should be checked regularly and retightened as necessary
- Recommended mattress size for upper bunk: 200cm x 90cm
- Maximum mattress thickness for the top bunk: 150mm
- Recommended mattress size for the bottom bunk: 200cm x 90cm
- Maximum mattress thickness for the bottom bunk: 150mm

The mark on the product indicates the maximum thickness of the mattress that can be used

FR - IMPORTANT - LIRE ATTENTIVEMENT - A CONSERVER POUR CONSULTATION ULTERIEURE

- EN 747-1/2:2024
- AVERTISSEMENT : Les lits surélevés et le lit supérieur des lits superposés ne conviennent pas pour les enfants de moins de six ans en raison du risque de blessures liées à des chutes
- AVERTISSEMENT : S'ils ne sont pas utilisés correctement, les lits superposés et les lits surélevés peuvent présenter un sérieux risque de blessure par étranglement. Ne jamais attacher ou suspendre des éléments à des parties du lit superposé qui ne sont pas destinés à être utilisés avec ledit lit. Ces éléments comprennent, sans toutefois s'y limiter, les cordes, les ficelles, les cordons, les crochets, les ceintures et les sacs
- AVERTISSEMENT : Les enfants peuvent se retrouver coincés entre le lit et un mur, une partie d'un toit incliné, le plafond, des meubles adjacents (par exemple, des placards) ou autre. Pour éviter tout risque de blessure grave, la distance entre la barrière de sécurité supérieure et les éléments environnants ne doit pas dépasser 75 mm ou doit être supérieure à 230 mm
- AVERTISSEMENT : Ne pas utiliser le lit superposé ou le lit surélevé si une pièce de la structure est manquante ou cassée
- Toujours suivre les instructions du fabricant
- Il est nécessaire de ventiler la pièce afin de maintenir un niveau peu élevé d'humidité et d'empêcher le développement de moisissure dans le lit et autour de celui-ci
- Tous les éléments de fixation doivent toujours être convenablement serrés et régulièrement vérifiés, et resserrés si nécessaire
- Taille de matelas recommandée pour le lit superposé supérieur : 200x90cm
- Épaisseur maximale du matelas à l'étage supérieur: 150mm
- Taille de matelas recommandée pour le lit superposé inférieur : 200x90cm
- Épaisseur maximale du matelas à l'étage inférieur : 150 mm
- La marque figurant sur le produit indique l'épaisseur maximale du matelas à utiliser

ASSEMBLY INSTRUCTION - ANLEITUNG

PT - IMPORTANTE - LER ESTAS INSTRUÇÕES CUIDADOSAMENTE - GUARDE PARA CONSULTA POSTERIOR

- EN 747-1/2:2024
- AVISO: as camas altas e a cama superior dos beliches não são adequados para crianças com menos de seis anos, devido ao risco de ferimentos resultantes de quedas.
- AVISO: se não forem devidamente usados, os beliches e a cama elevada podem constituir perigos de ferimentos graves por estrangulamento. Nunca pendure ou prenda nas peças da cama elementos que não sejam concebidos para ser usados com essa cama. Esses elementos incluem, entre outros, cordas, fios, ganchos, arneses, cintos e sacos.
- AVISO: as crianças podem ficar presas entre a cama e a parede, numa parte de um telhado reclinado, do teto, mobiliário adjacente (por exemplo, armários), entre outros. Para evitar qualquer perigo de ferimentos graves, a distância entre a parte superior da barreira de segurança e os elementos adjacentes não deverá exceder 75 mm ou não deve ser superior a 230 mm.
- AVISO: não use os beliches ou a cama elevada quando uma peça da estrutura estiver partida ou em falta
- As instruções do fabricante devem ser sempre cumpridas
- É necessário ventilar o quarto para manter um nível de humidade baixo, com vista a evitar a formação de mofo na cama e ao seu redor
- Todos os elementos de fixação devem estar sempre bem apertados e ser verificados com regularidade, e reapertados se necessário
- Tamanho de colchão recomendado para beliches acima de 200x90cm
- Espessura máxima do colchão no piso superior: 150mm
- Tamanho recomendado do colchão para beliche inferior: 200x90cm
- Espessura máxima do colchão no piso inferior: 150mm
- A marca no produto indica a espessura máxima do colchão a utilizar

ES - IMPORTANTE - LEER DETENIDAMENTE CONSERVAR PARA FUTURAS CONSULTAS

- EN 747-1/2:2024
- ADVERTENCIA: las camas altas y las camas superiores de las literas no son adecuadas para niños menores de seis años, debido al riesgo de lesiones por caída.
- ADVERTENCIA: si no se utilizan correctamente, las literas y las camas altas pueden provocar riesgo de lesiones graves por estrangulamiento. No cuelgue ni ate nunca a ninguna pieza de una cama elementos que no hayan sido diseñados para el uso con dicha cama. Esos elementos incluyen, entre otros, cuerdas, cintas, ganchos, arneses, correas y bolsas.
- ADVERTENCIA: los niños pueden quedar atrapados entre la cama y una pared, una parte de un tejado inclinado, el techo o un mueble cercano (por ejemplo, un armario), entre otros. Para evitar cualquier riesgo de lesiones graves, la distancia entre la barrera de seguridad superior y los elementos adyacentes no debe superar 75 mm, o debe ser mayor que 230 mm.
- ADVERTENCIA: No use las literas o camas altas si falta alguna parte del bastidor o si está dañado.
- Deben seguirse siempre las instrucciones del fabricante.
- Es necesario ventilar la habitación para mantener un nivel de humedad bajo y evitar la formación de moho en la cama y a su alrededor.

-
-
-
-

ASSEMBLY INSTRUCTION - ANLEITUNG

DE - WICHTIG - SORGFÄLTIG LESEN - FÜR SPÄTERE BEZUGNAHME AUFBEWAHREN

- EN 747-1/2:2024
- **WARNHINWEIS:** Hochbetten und das obere Bett von Stockbetten sind aufgrund der Gefahr sturzbedingter Verletzungen für Kinder unter sechs Jahren nicht geeignet
- **WARNHINWEIS :** Bei unsachgemäßem Gebrauch kann bei Stockbetten und Hochbetten ernsthafte Gefahr von Verletzungen durch Strangulieren bestehen. An Stockbetten dürfen niemals Gegenstände befestigt oder aufgehängt werden, die nicht zur Verwendung mit dem betreffenden Bett bestimmt sind. Zu solchen Gegenständen zählen unter anderem Schnüre, Fäden, Bänder, Haken, Gürtel oder Taschen
- **WARNHINWEIS :** Kinder können zwischen dem Bett und einer Wand, einer Dachschräge, der Zimmerdecke, angrenzender Möbel (zum Beispiel Schränken) oder anderen Objekten eingeklemmt werden. Um der Gefahr schwerer Verletzungen vorzubeugen, darf der Abstand zwischen der oberen Absturzsicherung und den umgebenden Elementen 75 mm nicht überschreiten oder muss größer als 230 mm sein
- **WARNHINWEIS :** Stockbett oder Hochbett nicht benutzen, wenn ein Teil des Aufbaus fehlt oder defekt ist
- Stets die Herstelleranweisungen beachten
- Das Zimmer muss ausreichend gelüftet werden, um die Luftfeuchtigkeit zu verringern und Schimmelbildung im Bett und rund um das Bett zu verhindern
- Alle Befestigungselemente müssen stets ordnungsgemäß festgezogen und regelmäßig überprüft und gegebenenfalls nachgezogen werden.
- Empfohlene Matratzengröße für Etagenbetten über 200x90 cm
- Maximale Matratzenstärke im Obergeschoss: 150 mm
- Empfohlene Matratzengröße für das untere Etagenbett: 200x90 cm
- Maximale Matratzenstärke im Untergeschoss: 150 mm
- Die Markierung am Produkt gibt die maximale Dicke der zu verwendenden Matratze an

IT - IMPORTANTE - LEGGI ATTENTAMENTE - CONSERVARE QUESTE INFORMAZIONI PER ULTERIORI CONSULTAZIONI

- EN 747-1/2:2024
 - **AVVERTENZA:** le letti rialzati e il letto superiore dei letti a castello non sono adatti ai bambini di età inferiore a sei anni a causa del rischio di infortuni dovuti a cadute.
 - **AVVERTENZA:** se non utilizzati correttamente, i letti a castello e i letti rialzati possono comportare un grave rischio di infortuni da strangolamento. Non fissare o appendere mai elementi a parti del letto a castello non destinati a essere utilizzati con il letto. Questi elementi comprendono, in via esemplificativa e non esaustiva, corde, lacci, cordoni, ganci, cinture e sacchetti.
 - **AVVERTENZA:** i bambini possono rimanere incastrati tra il letto e un muro, una parte di tetto inclinato, il soffitto, i mobili adiacenti (ad esempio armadi) o altro. Per evitare il rischio di gravi infortuni, la distanza tra la barriera di sicurezza superiore e gli elementi circostanti non deve essere superiore a 75 mm o deve essere superiore a 230 mm.
 - **AVVERTENZA:** non utilizzare il letto a castello o il letto rialzato se una parte della struttura è mancante o danneggiata.
 - Seguire sempre le istruzioni del costruttore.
 - Occorre ventilare il locale per mantenere un basso livello di umidità e impedire lo sviluppo di muffa all'interno e intorno al letto.
 - Tutti gli elementi di fissaggio devono essere sempre correttamente serrati e periodicamente controllati.
 - Recommended mattress size for lower bunk bed: 200x90cm
 - Maximum mattress thickness on the lower floor: 150mm
 - Recommended mattress size for bunk beds above 200x90cm
 - Maximum mattress thickness on upper floor: 150mm
- Il marchio sul prodotto indica lo spessore massimo del materasso utilizzabile

ASSEMBLY INSTRUCTION - ANLEITUNG

NL - BELANGRIJK - LEES AANDACHTIG - BEWAAR VOOR LATERE RAADPLEGING:

- EN 747-1/2:2024
- WAARSCHUWING: hoge bedden en het bovenste bed van stapelbedden zijn niet geschikt voor kinderen onder de zes jaar omwille van het risico op letsel door een valpartij
- WAARSCHUWING: indien ze niet correct worden gebruikt, kunnen stapelbedden en verhoogde bedden ernstig letsel veroorzaken door wurging. Hang of bind nooit iets vast aan delen van het bed die niet bestemd zijn voor gebruik met dat bed. Deze elementen zijn onder andere touwen, koorden, haken, harnassen, riemen en zakken
- WAARSCHUWING: kinderen kunnen verstrikt raken tussen het bed en een muur, een deel van een hellend dak, het plafond, meubelen in de buurt (kasten bijvoorbeeld), enz. Om ernstig risico te vermijden, moet de afstand tussen de bovenste veiligheidsbarrière en de aangrenzende elementen niet meer dan 75 mm bedragen of meer zijn dan 230 mm
- WAARSCHUWING: gebruik de stapelbedden of het verhoogde bed niet wanneer een deel van het frame ontbreekt of kapot is
- De instructies van de fabrikant dienen te allen tijde gevolgd te worden
- Het is nodig om de kamer te ventileren om een laag vochtigheidsniveau te behouden om te voorkomen dat er zich schimmel vormt in het bed en errond
- Alle bevestigingen moeten altijd juist zijn vastgemaakt, regelmatig worden gecontroleerd en, indien nodig, opnieuw worden vastgemaakt.
- Aanbevolen matrasmaat voor stapelbedden groter dan 200x90cm
- Maximale matrasdikte op de bovenverdieping: 150 mm
- Aanbevolen matrasmaat voor onderste stapelbed: 200x90cm
- Maximale matrasdikte op de benedenverdieping: 150 mm
- Het teken op het product heeft de maximale te gebruiken dikte van de matras aan

ASSEMBLY INSTRUCTION - ANLEITUNG

TIPS

1. This set comes in 5 boxes. If you don't receive a full 5 boxes, please contact our customer service.
2. Please read the instructions fully before assembly. These instructions include important information which could ensure correct assembly.
We have been working on providing high quality products for you. However, in the rare instance that your product is defective, missing parts or there are some issues, please don't hesitate to contact our customer service to submit parts requirements, assembly suggestion, or warranty claims, and we will give the best solution as soon as possible. If necessary, we need you to provide some more clear pictures of the issue.
3. Insert the screws in holes and tighten the screws, but not too tight, 70%~80% is ok, finally tighten all the screws. If some issues happened that some screws can not target to the hole or some parts are difficult to install, please adjust the tightness of the screws.
4. 2 people are recommended to finish.

TIPPS



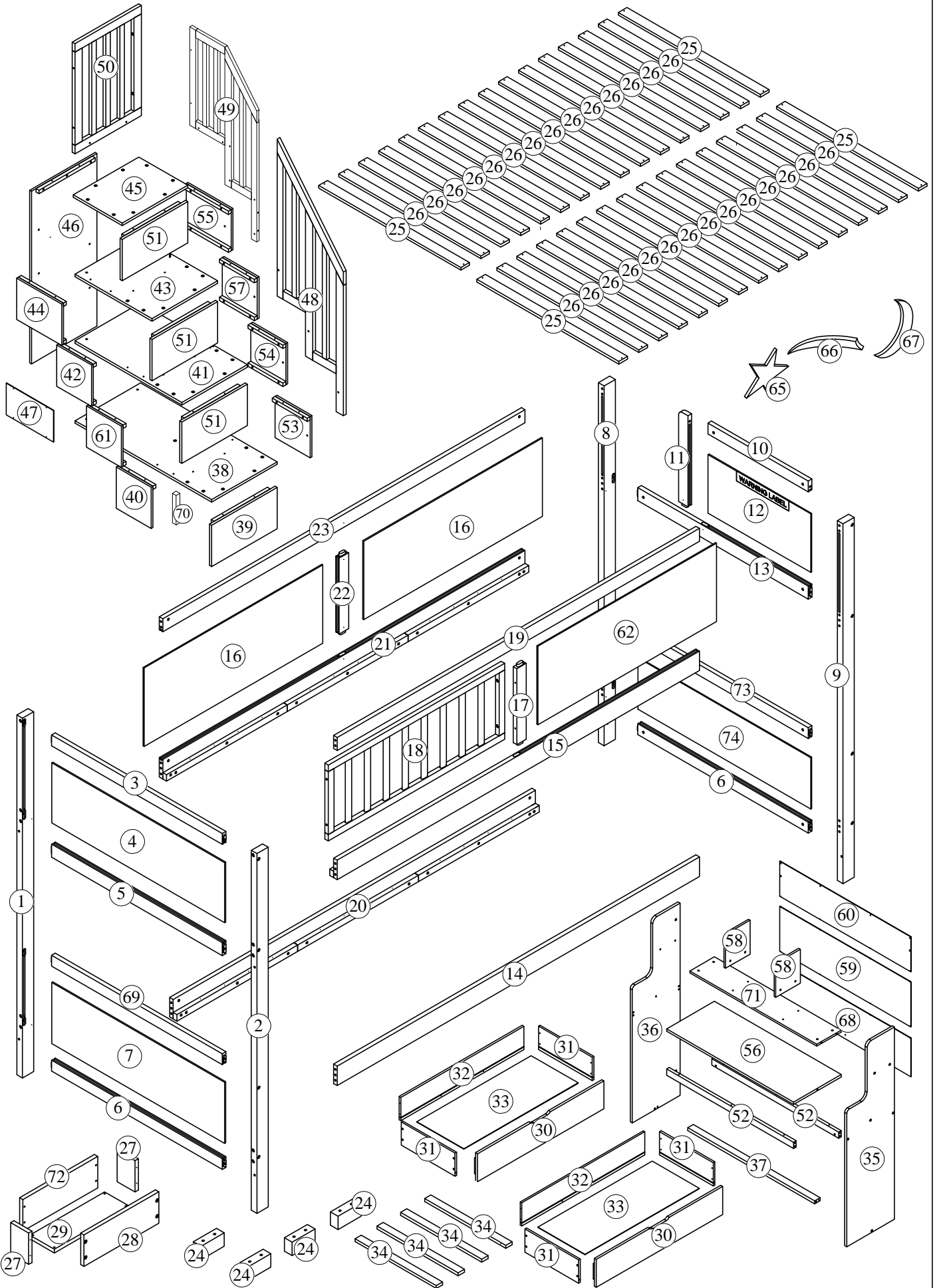

1. Dieses Set kommt in 5- Boxen. Wenn Sie keine Vollständige 5-Boxen, kontaktieren Sie bitte unseren Kundenservice.
2. Bitte lesen Sie vorher die Anweisungen vollständig durch Montage. Diese Anweisungen enthalten wichtige Informationen
Informationen, die eine korrekte Montage gewährleisten können. Wir haben daran gearbeitet, eine hohe Qualität zu bieten
Produkte für Sie. Allerdings im seltenen Fall dass Ihr Produkt defekt ist, Teile fehlen oder
Es gibt einige Probleme, bitte zögern Sie nicht Kontaktieren Sie unseren Kundenservice, um Teile einzusenden
Anforderungen, Montagevorschlag oder Garantie Ansprüche, und wir werden so bald wie möglich die beste Lösung anbieten
wie möglich. Bei Bedarf benötigen wir Ihre Bereitstellung einige klarere Bilder des Problems.
3. Setzen Sie die Schrauben in die Löcher ein und ziehen Sie sie fest Schrauben, aber nicht zu fest, 70 % ~ 80 % sind endlich in Ordnung
Ziehen Sie alle Schrauben fest. Wenn einige Probleme aufgetreten sind dass manche Schrauben nicht ins Loch gelangen bzw
Einige Teile sind schwierig zu installieren, bitte anpassen die Festigkeit der Schrauben.
4. Zum Fertigstellen werden 2 Personen empfohlen.

ASSEMBLY INSTRUCTION - ANLEITUNG



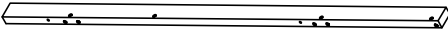
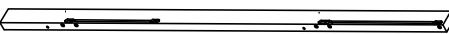
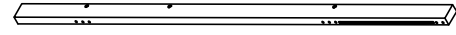
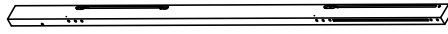
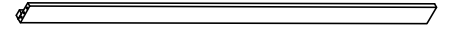



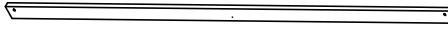

Part List (Box 1-N623P357270)

Teileliste

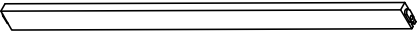
<p>1</p>  <p>Back left leg- 1 pc Pied arrière gauche</p>	<p>2</p>  <p>Front left leg- 1 pc Pied avant gauche</p>	<p>8</p>  <p>Front right leg- 1 pc Pied avant droit</p>
<p>9</p>  <p>Back right leg- 1 pc Pied arrière droit</p>	<p>14</p>  <p>Lower front bed rail - 1 pc Longeron avant inférieur</p>	<p>15</p>  <p>Upper window panel - 1pc Panneau supérieur de fenêtre</p>
<p>19</p>  <p>Front upper horizontal bar - 1pc Barre horizontale supérieure avant</p>	<p>20</p>  <p>Lower back bed rail - 1 pc Longeron arrière inférieur</p>	<p>21</p>  <p>Upper rear bed rail- 1pc Longeron arrière supérieur du lit</p>
<p>23</p>  <p>Rear upper horizontal bar - 1 pc Barre horizontale supérieure arrière</p>		

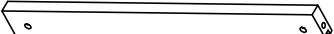

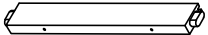
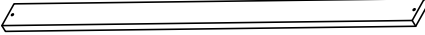
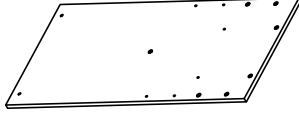
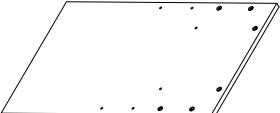
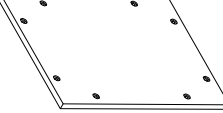
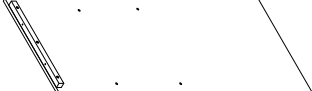

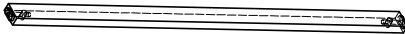
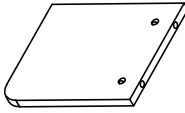

Part List (Box 2-N623P357271)

Teileliste

<p>3</p>  <p>Left guard rail bar- 1pc Barre de garde gauche</p>	<p>5</p>  <p>Upper left bed rail- 1 pc Panneau latéral inférieur</p>	<p>6</p>  <p>Left guard rail bar- 2pcs Barre de garde gauche</p>
<p>10</p>  <p>Right vertical rail of side frame - 1pc Traverse verticale droite du cadre latéral</p>	<p>11</p>  <p>Right guard vertical post - 1 pc Montant vertical de garde droit</p>	<p>13</p>  <p>Upper right bed rail - 1 pc Longeron droit supérieur du lit</p>
<p>17</p>  <p>Guard vertical post - 1 pc Montant vertical de garde</p>	<p>26</p>  <p>Slats - 8 pcs Lattes</p>	<p>38</p>  <p>Step panel - 1 pc Panneau de marche</p>
<p>41</p>  <p>Step panel - 1 pc Panneau de marche</p>	<p>45</p>  <p>Step panel - 1 pc Panneau de marche</p>	<p>46</p>  <p>Stair back panel - 1 pc Panneau arrière escalier</p>
<p>50</p>  <p>Back railing frame - 1 pc Cadre arrière de rambarde</p>	<p>52</p>  <p>Desk support bar - 1pc Barre de support du bureau</p>	<p>58</p>  <p>Panneau horizontal de l'étagère -2pcs Panneau vertical de l'étagère du bureau</p>

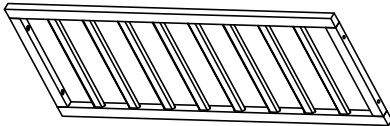
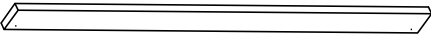
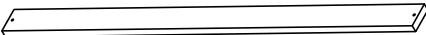

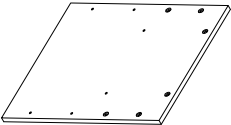
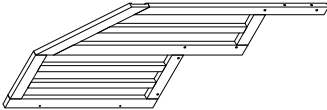
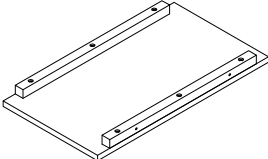
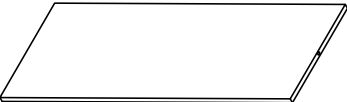
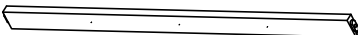
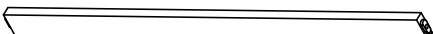





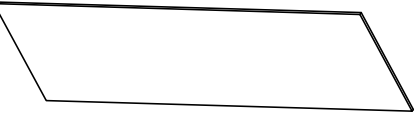

Part List (Box 3-N623P357272)

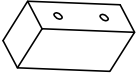
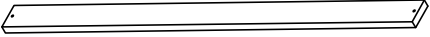
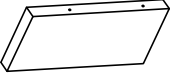
Teileliste

<p>7</p>  <p>Side panel- 1pc Panneau latéral</p>	<p>12</p>  <p>Right guardrail panel - 1 pc Panneau de garde-corps droit</p>	<p>18</p>  <p>Front upper lifting frame - 1pc Cadre de levage supérieur avant</p>
<p>25</p>  <p>Slats - 4 pcs Latte</p>	<p>26</p>  <p>Slats - 5 pcs Latte</p>	<p>32</p>  <p>Drawer back panel - 2pcs Panneau arrière du tiroir</p>
<p>43</p>  <p>Step panel - 1 pc Panneau de marche</p>	<p>49</p>  <p>Side railing frame - 1 pc Cadre latéral de rambarde</p>	<p>51</p>  <p>Front panel - 2 pcs Panneau avant</p>
<p>56</p>  <p>Right stair side - 1 pc Côté gauche escalier</p>	<p>69</p>  <p>Left guard rail bar- 1pc Barre de garde gauche</p>	<p>73</p>  <p>Left guard rail bar- 1pc Barre de garde gauche</p>
<p>74</p>  <p>Side panel- 1pc Panneau latéral</p>		

Part List (Box 4-N623P357273)

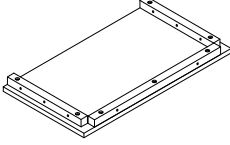
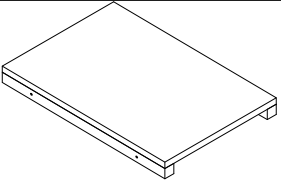
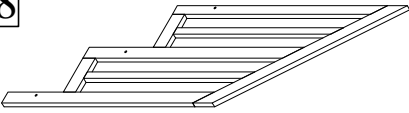
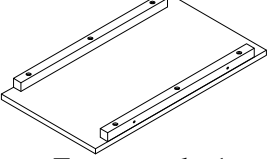
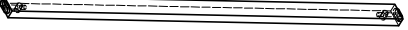
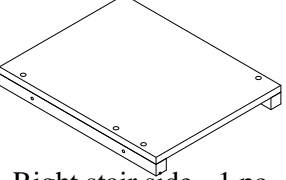
Teileliste

<p>4</p>  <p>Side Panel - 1pc Panneau latéral</p>	<p>16</p>  <p>Front guardrail panel - 2 pcs Panneau de garde-corps avant</p>	<p>22</p>  <p>Guard vertical post - 1 pc Montant vertical de garde</p>
<p>24</p>  <p>Wooden plug - 4 pcs Bouchon en bois</p>	<p>26</p>  <p>Slats - 15 pcs Latte</p>	<p>27</p>  <p>Box side panel - 2 pcs Panneau latéral de la boîte</p>
<p>28</p>  <p>Box front panel 1pc Panneau avant de la boîte</p>	<p>29</p>  <p>Box bottom panel - 1pc Panneau inférieur de la boîte</p>	<p>31</p>  <p>Drawer side panel - 4 pcs Panneau latéral du tiroir</p>
<p>34</p>  <p>Drawer bottom support - 4 pcs Support inférieur du tiroir</p>	<p>37</p>  <p>Bottom bar of the desk- 1pc Support inférieur du tiroir</p>	<p>39</p>  <p>Front panel - 1 pc Panneau avant</p>
<p>44</p>  <p>Left stair side - 1 pc Côté gauche escalier</p>	<p>48</p>  <p>Side railing frame - 1 pc Cadre latéral de rambarde</p>	<p>51</p>  <p>Front panel - 1 pc Panneau avant</p>
<p>52</p>  <p>Desk support bar - 1pc Barre de support du bureau</p>	<p>55</p>  <p>Right stair side - 1 pc Côté gauche escalier</p>	<p>59</p>  <p>Back panel of the desk - 1pc Panneau arrière du bureau</p>

Part List (Box 4-N623P357273)

Teileliste

72

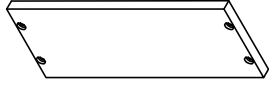

Box back panel - 1 pc
Barre de support avant du bureau

62

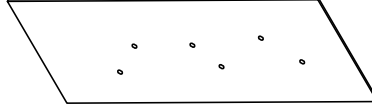

Front top panel - 1pc
Panneau supérieur avant

65

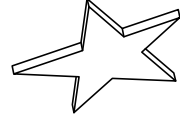

Decorative panel - 1pc
Panneau décoratif

66



Decorative panel - 1pc
Panneau décoratif

67



Decorative panel - 1pc
Panneau décoratif



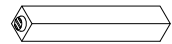

70



- 1 pc
Côté gauche escalier

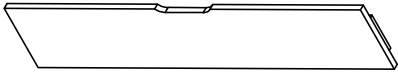
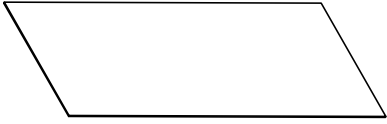

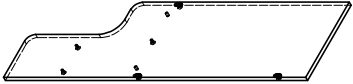
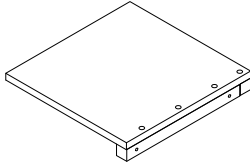
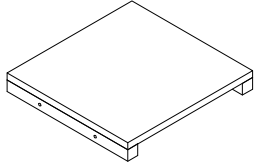
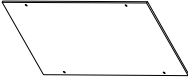
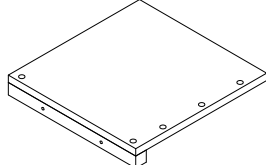
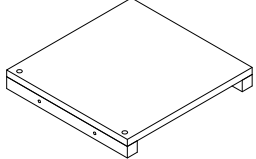
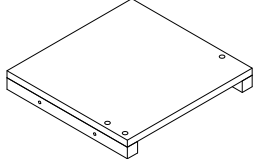

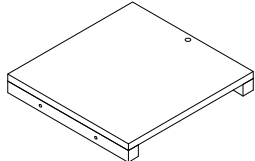
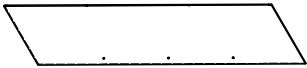
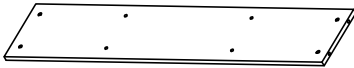

Part List (Box-5 N623P357274)

Teileliste

<p>30</p>  <p>Drawer front panel- 2pcs Panneau latéral du tiroir</p>	<p>33</p>  <p>Drawer bottom panel - 2 pcs Panneau inférieur du tiroir</p>	<p>35</p>  <p>Side panel of the desk frame- 1pc Panneau latéral du cadre de bureau</p>
<p>36</p>  <p>Side panel of the desk frame- 1pc Panneau latéral du cadre de bureau</p>	<p>40</p>  <p>Left stair side - 1 pc Côté gauche escalier</p>	<p>42</p>  <p>Left stair side - 1 pc Côté gauche escalier</p>
<p>47</p>  <p>Support panel - 1 pc Panneau de support</p>	<p>53</p>  <p>Right stair side - 1 pc Côté gauche escalier</p>	<p>54</p>  <p>Right stair side - 1pc Côté gauche escalier</p>
<p>57</p>  <p>Right stair side - 1pc Côté gauche escalier</p>	<p>60</p>  <p>Back panel of the desk - 1pc Panneau arrière du bureau</p>	<p>61</p>  <p>Left stair side - 1 pc Côté gauche escalier</p>
<p>68</p>  <p>Back panel of the desk - 1pc Panneau arrière du bureau</p>	<p>71</p>  <p>Shelf horizontal panel - 1 pc Panneau horizontal de l'étagère</p>	

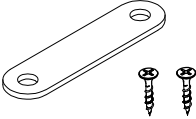
Hardware List (Box 1-N623P357270)

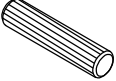
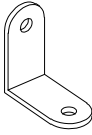
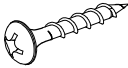
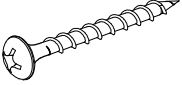
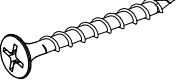
Hardwareliste

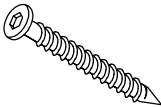
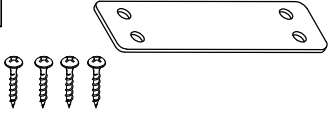
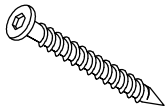
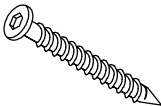
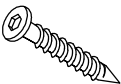

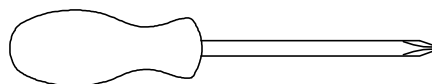
<p>A</p>  <p>Ø1/4" x 70 mm Hex-Head bolts 15pcs Sechskantschrauben 15 Stück</p>	<p>B</p>  <p>Ø1/4" x 90 mm Hex-Head bolts 1pc Sechskantschrauben 1 Stück</p>	<p>C</p>  <p>Ø1/4" x 12 mm Horizontal-Hole bolts 60pcs Sechskantschrauben 60 Stück</p>
<p>D</p>  <p>Flat metal plate - 4sets Pièce métallique plate</p>	<p>E</p>  <p>Screws 1/4" x45 - 4pcs Schrauben - 4 Stück</p>	<p>F</p>  <p>Ø1/4" x 100 mm Hex-Head bolts 24pcs Sechskantschrauben 24 Stück</p>
<p>G</p>  <p>Ø8 x 30 mm Wood dowel 22pcs Cheville en bois 22pcs</p>	<p>H</p>  <p>Angle Metal- 12 pcs Angle en métal 12 pcs</p>	<p>I</p>  <p>M4 x 15 mm Wood Screws 69pcs Vis à bois 69 pcs</p>
<p>J</p>  <p>M4 x 35 mm Wood Screws 64pcs Vis à bois 64pcs</p>	<p>K</p>  <p>M4 x 30 mm Wood Screws 14pcs Vis à bois 14pcs</p>	<p>L</p>  <p>Screws 1/4" x50 - 15pcs Vis 15 pcs</p>
<p>M</p>  <p>Ø1/4" x 50 mm Hex-Head bolts 20pcs Boulons à tête hexagonale 20pcs</p>	<p>N</p>  <p>Screws 1/4" x60 - 4pcs Vis 4pcs</p>	<p>O</p>  <p>Flat metal plate - 2sets Pièce métallique plate</p>
<p>P</p>  <p>Screws 1/4" x65 - 2pcs Vis 2 pcs</p>	<p>Q</p>  <p>Screws 1/4" x90 - 1pc Vis 90 pc</p>	<p>R</p>  <p>Screws 1/4" x30 - 50cs Vis 50 pcs</p>



Assembly Tools Required (Not Included)
Outils d'assemblage requis (non inclus)

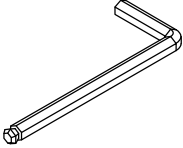
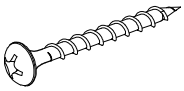
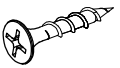
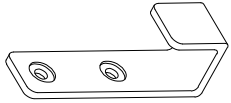
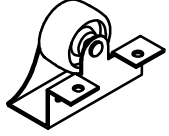
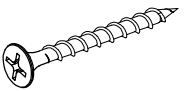
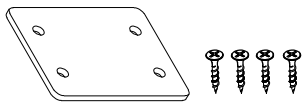
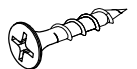
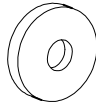

Hardware List (Box 1-N623P357270)

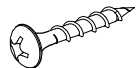
Hardwareliste

<p>U</p>  <p>Allen Key 4pcs Clé Allen 4 pièces</p>	<p>V</p>  <p>M4 x 25 mm Wood Screws 4pcs Vis à bois 4pcs</p>	<p>W</p>  <p>M3.5 x 12 mm Wood Screws 4pcs Vis à bois 4pcs</p>
<p>X</p>  <p>U bracket- 2 pcs Support en U</p>	<p>Y</p>  <p>Wheels 8pcs Roues 8 pcs</p>	<p>AA</p>  <p>M4 x 25 mm Wood Screws 28pcs Vis à bois 28 pcs</p>
<p>AB</p>  <p>Flat metal plate - 1set Pièce métallique plate</p>	<p>AC</p>  <p>M4 x 10 mm Wood Screws 6pcs Vis à bois 6 pcs</p>	<p>AD</p>  <p>Washer -8pcs Rondelle - 8pcs</p>
<p>AE</p>  <p>Ø1/4" x 30 mm Hex-Head bolts 1pc Sechskantschrauben 1 Stück</p>	<p>AG</p>  <p>M3.5 x 12 mm Wood Screws 14pcs Vis à bois 14pcs</p>	

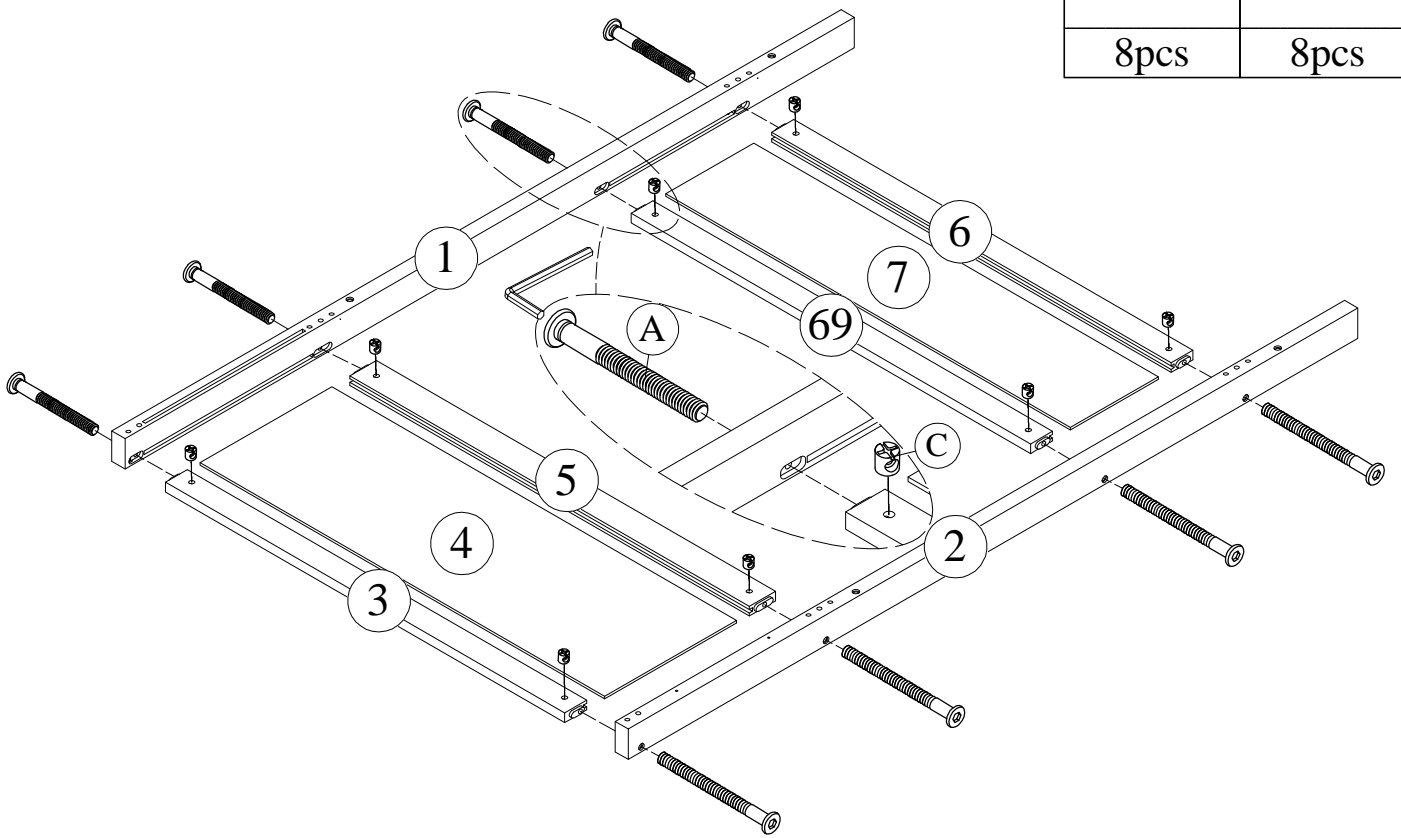

Step - Schritt-1



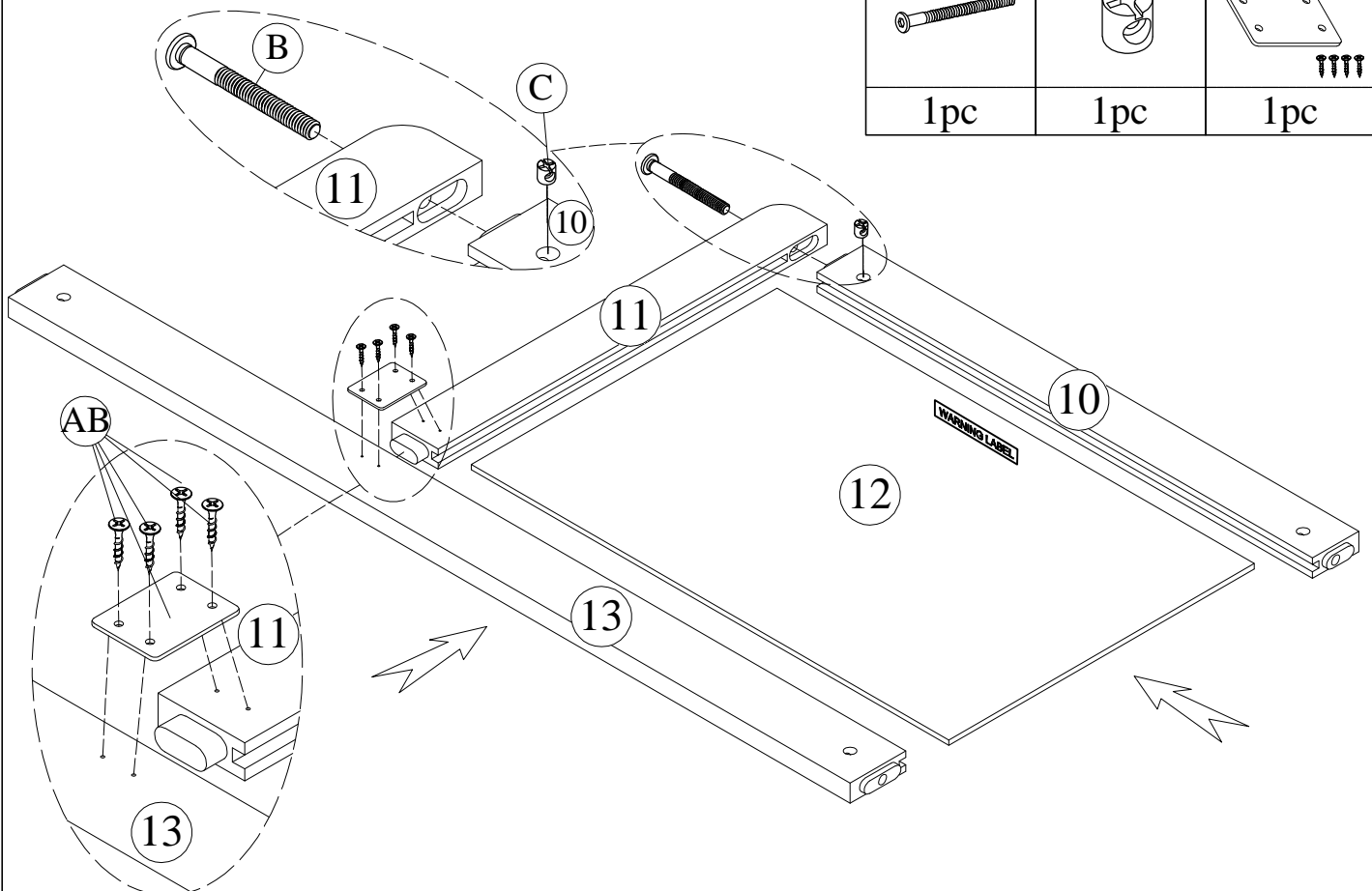

A	C
	
8pcs	8pcs

Step - Schritt-2

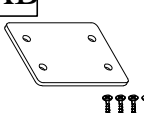

B	C	AB
		
1pc	1pc	1pc

Step - Schritt-3

A	C
	
7pcs	7pcs

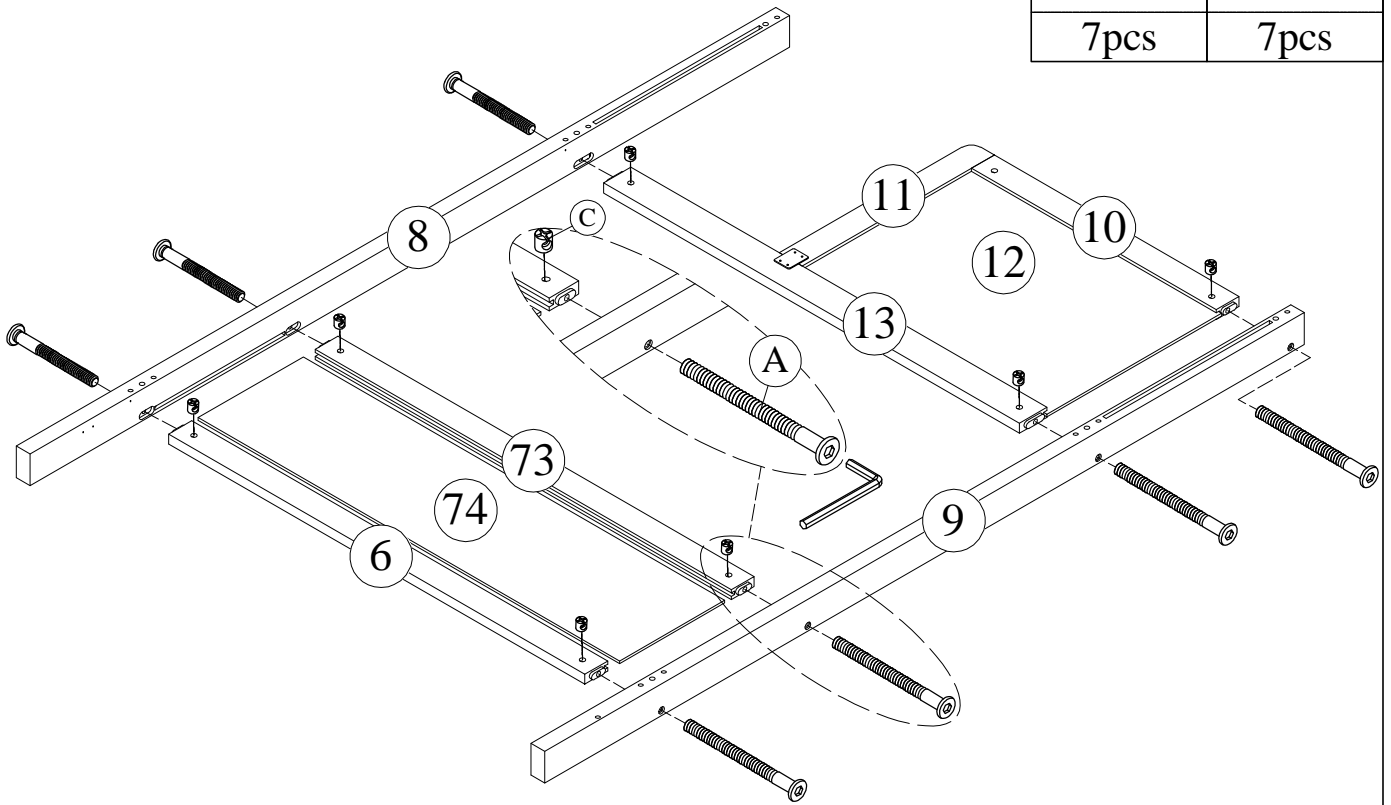

Step - Schritt-4

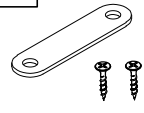
D

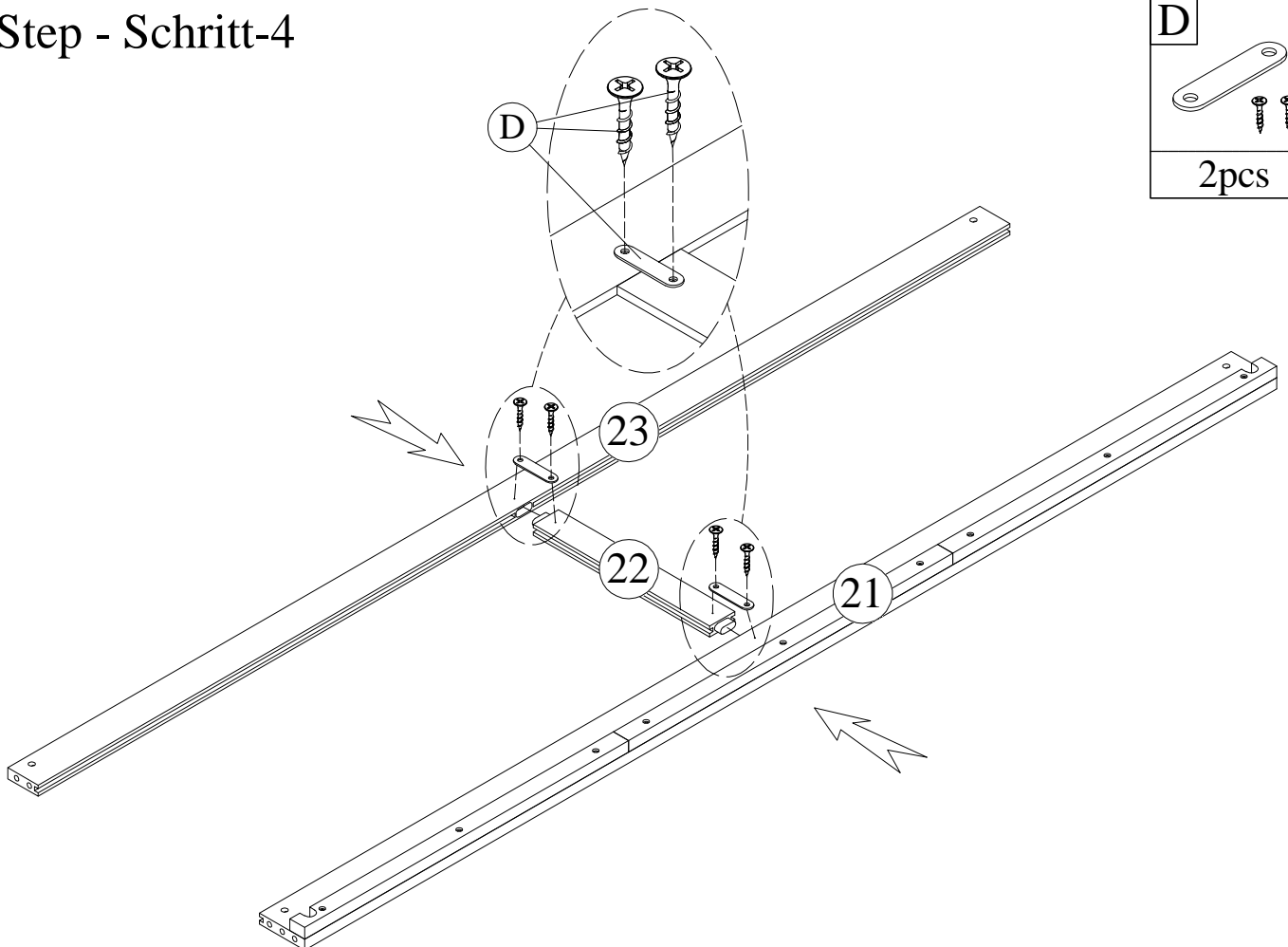
2pcs

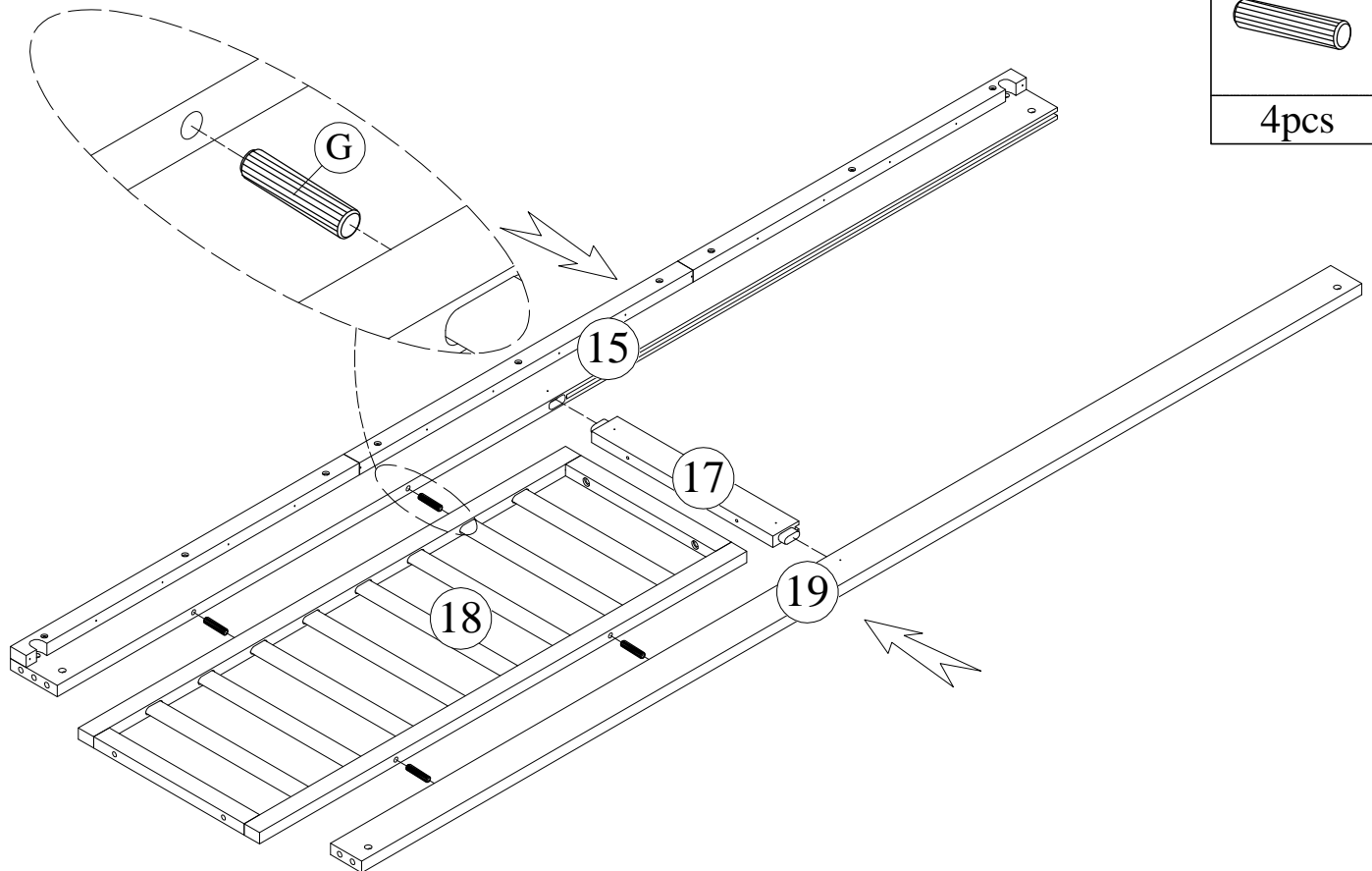

Step - Schritt-5

G

4pcs

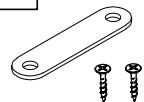

Step - Schritt-6

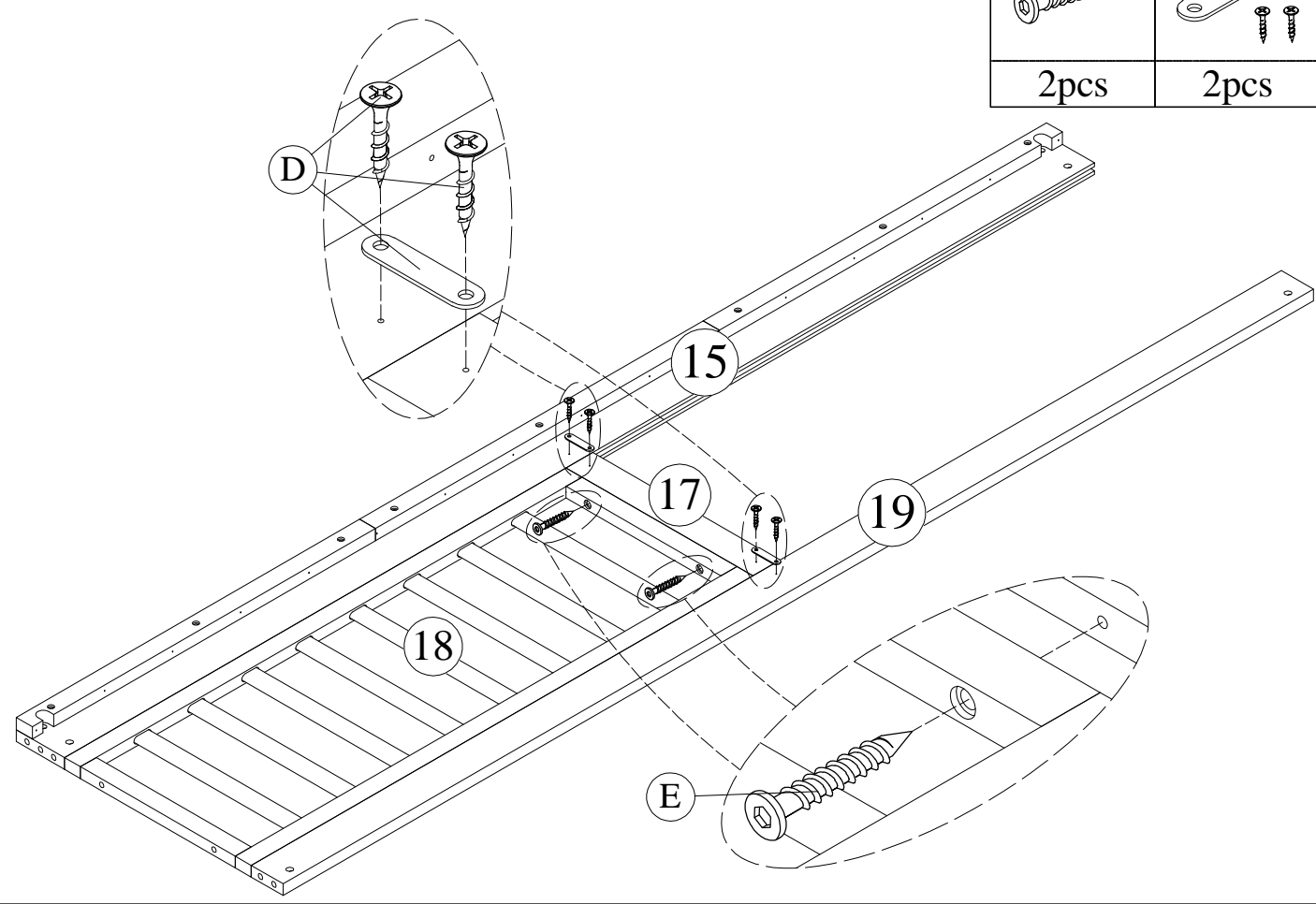
E	D
	
2pcs	2pcs



Step - Schritt-7

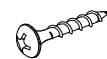

AC

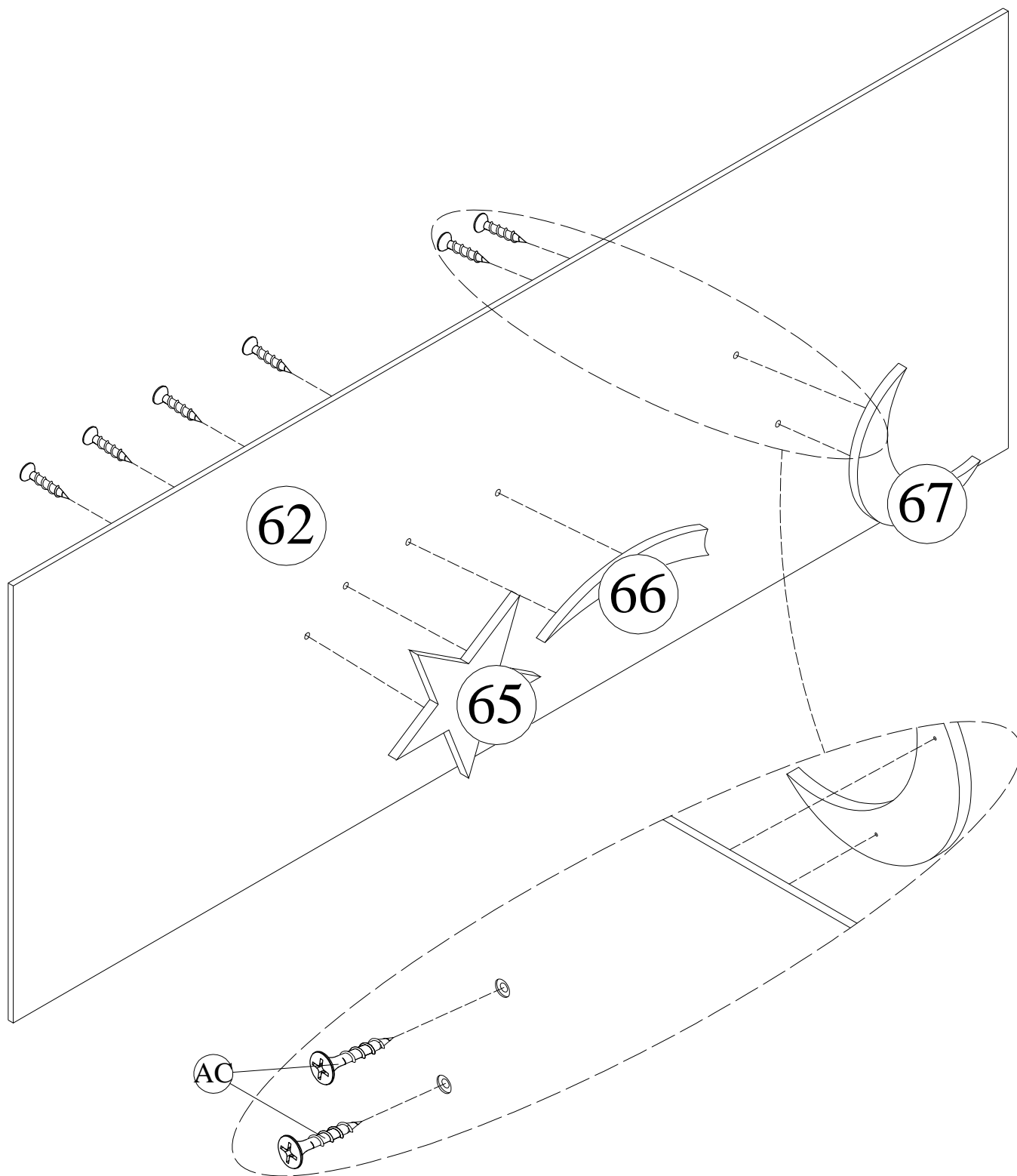

6pcs



Step - Schritt-8

C		G		F	
	20pcs		12pcs		20pcs

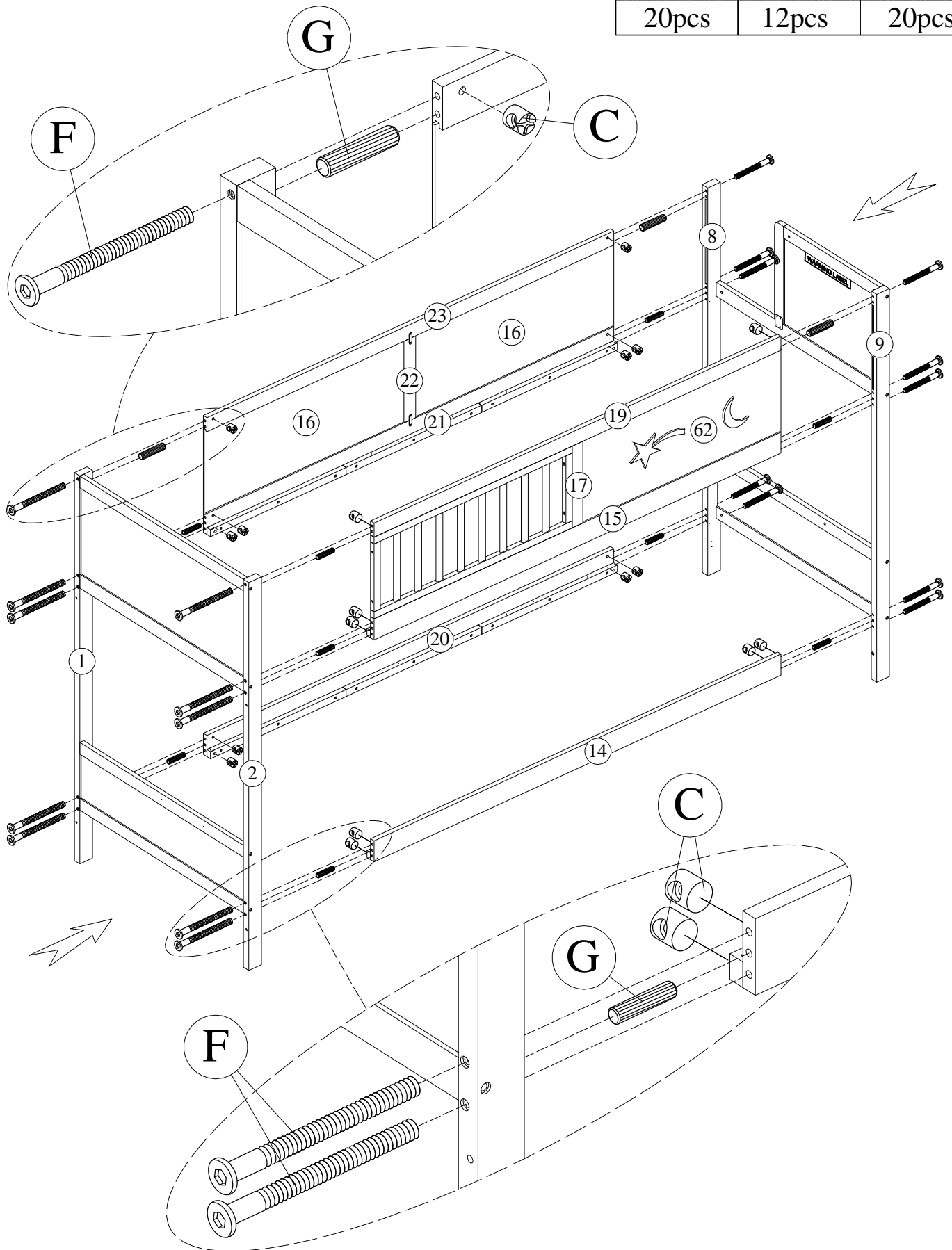

Step - Schritt-9

E



45
2pcs

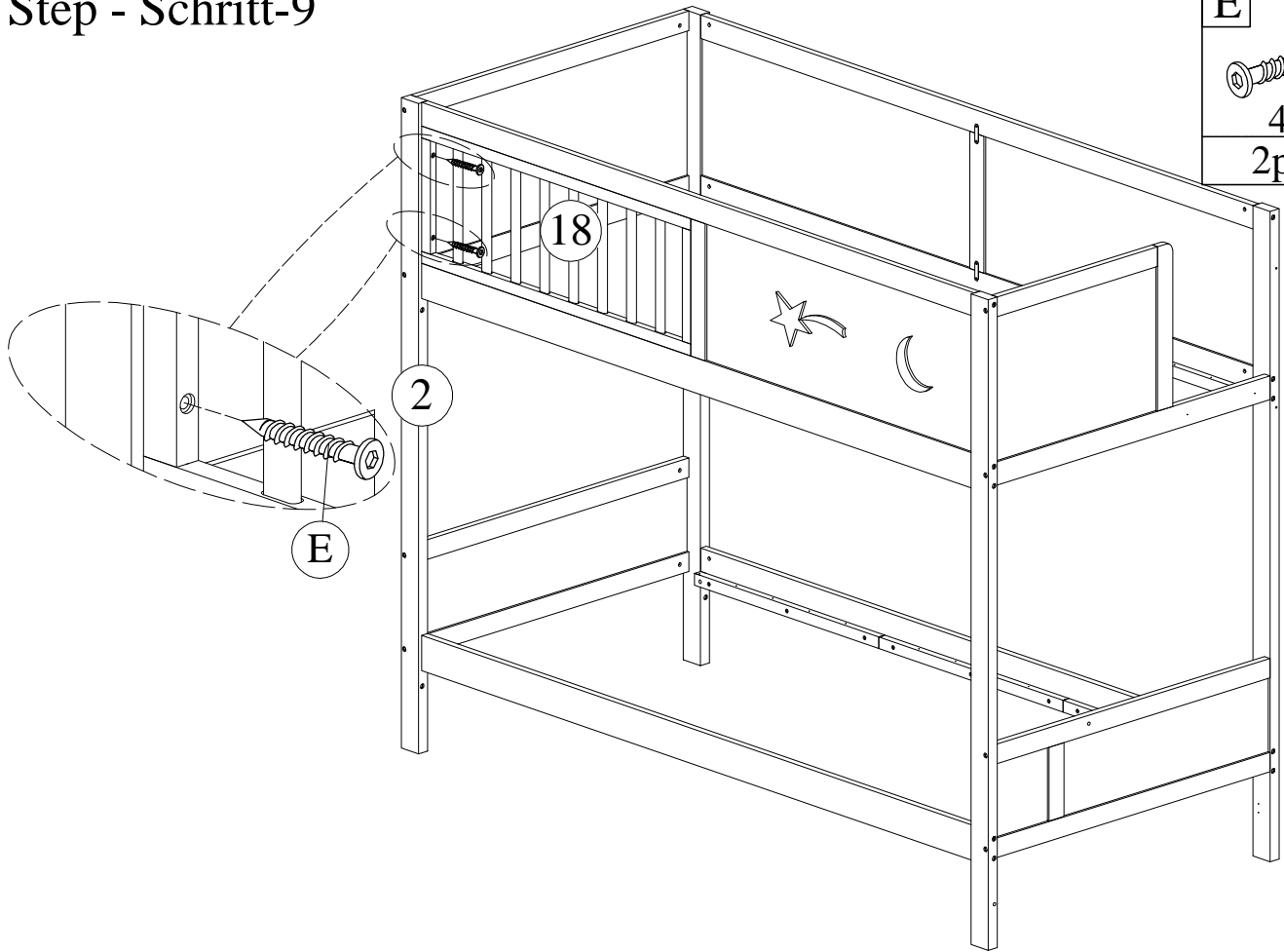

Step - Schritt-10

I

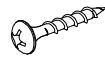

8pcs

H



8pcs

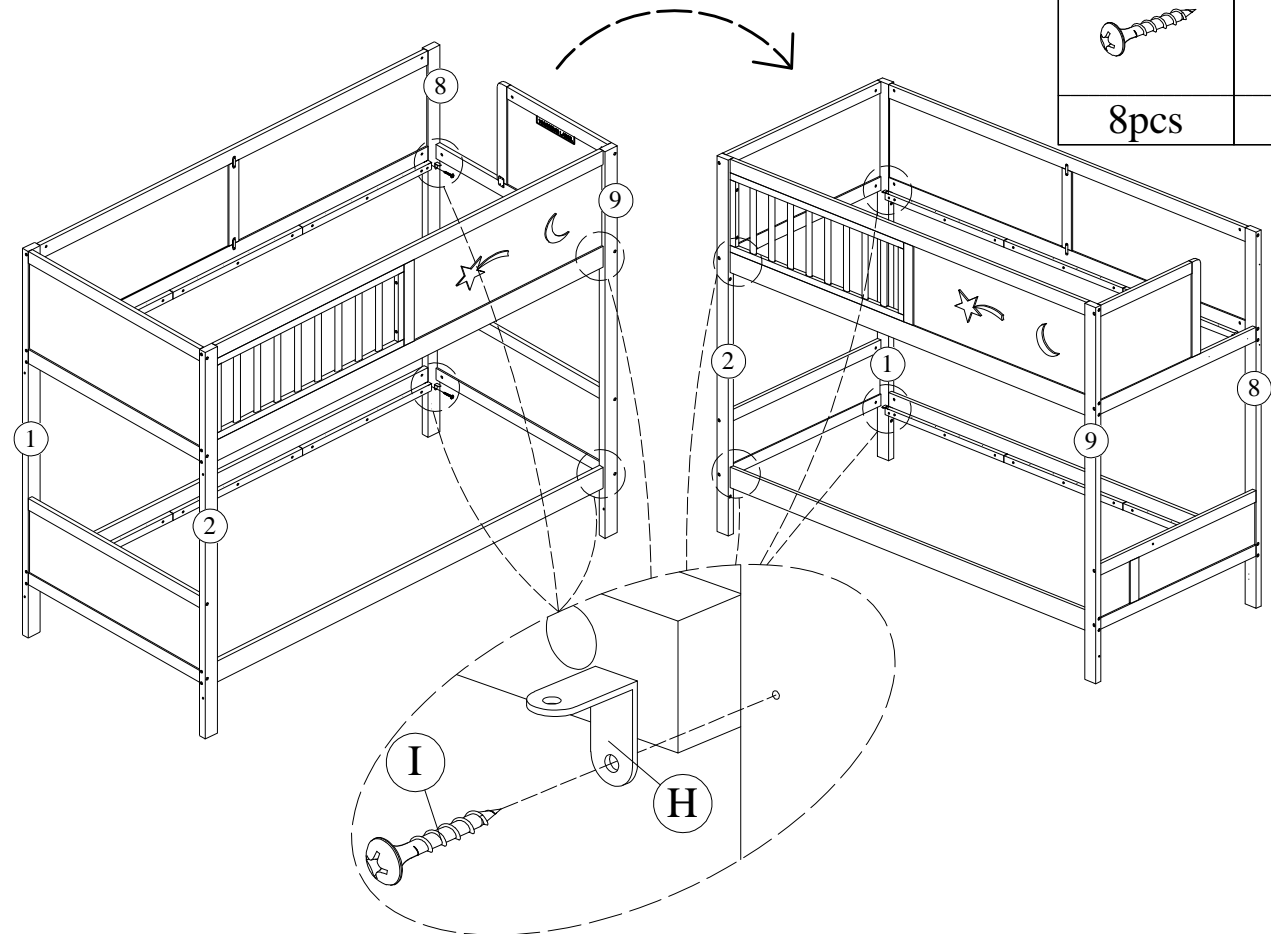

Step - Schritt-11

J



8pcs

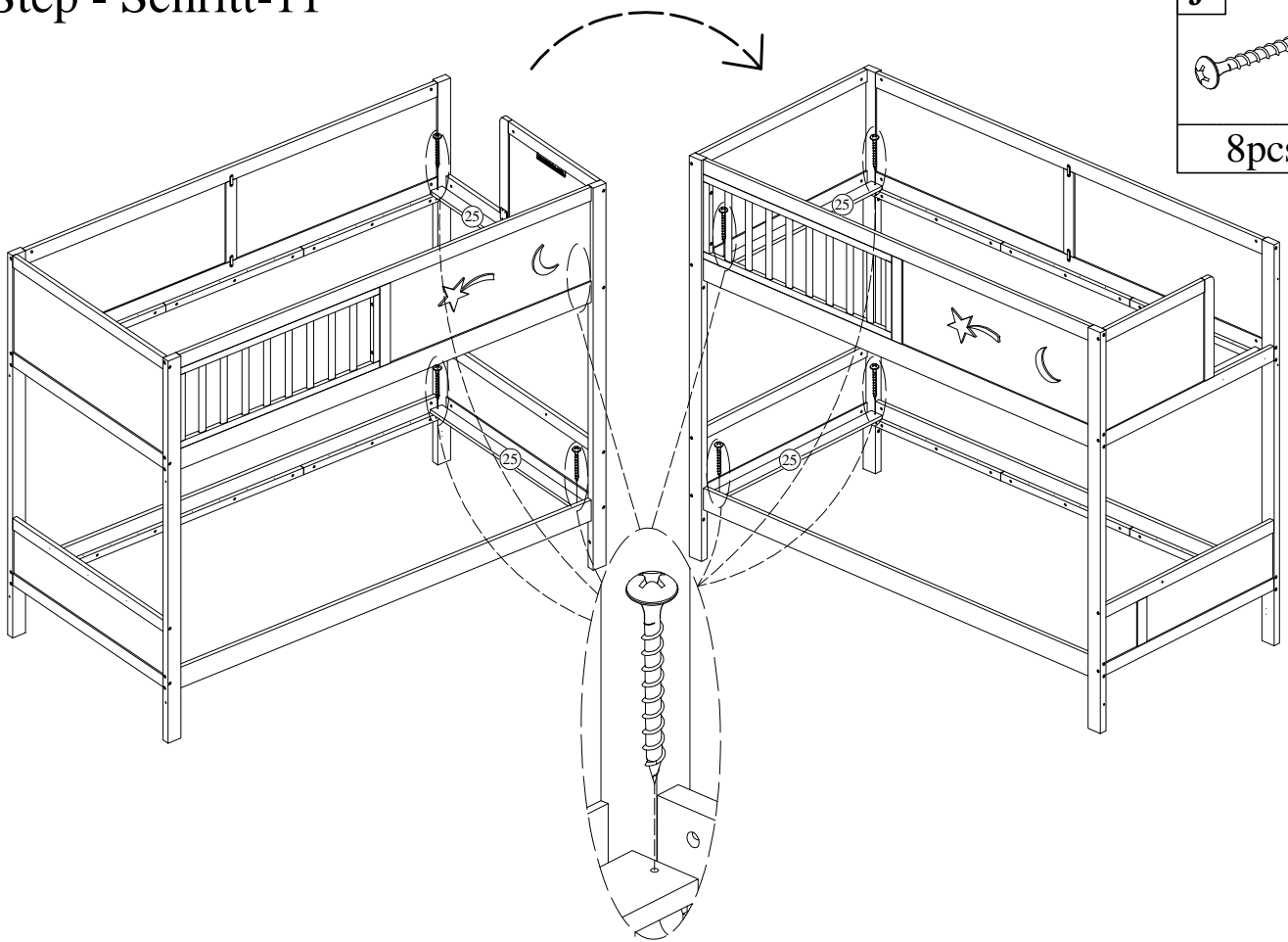

Step - Schritt-12

I



8pcs

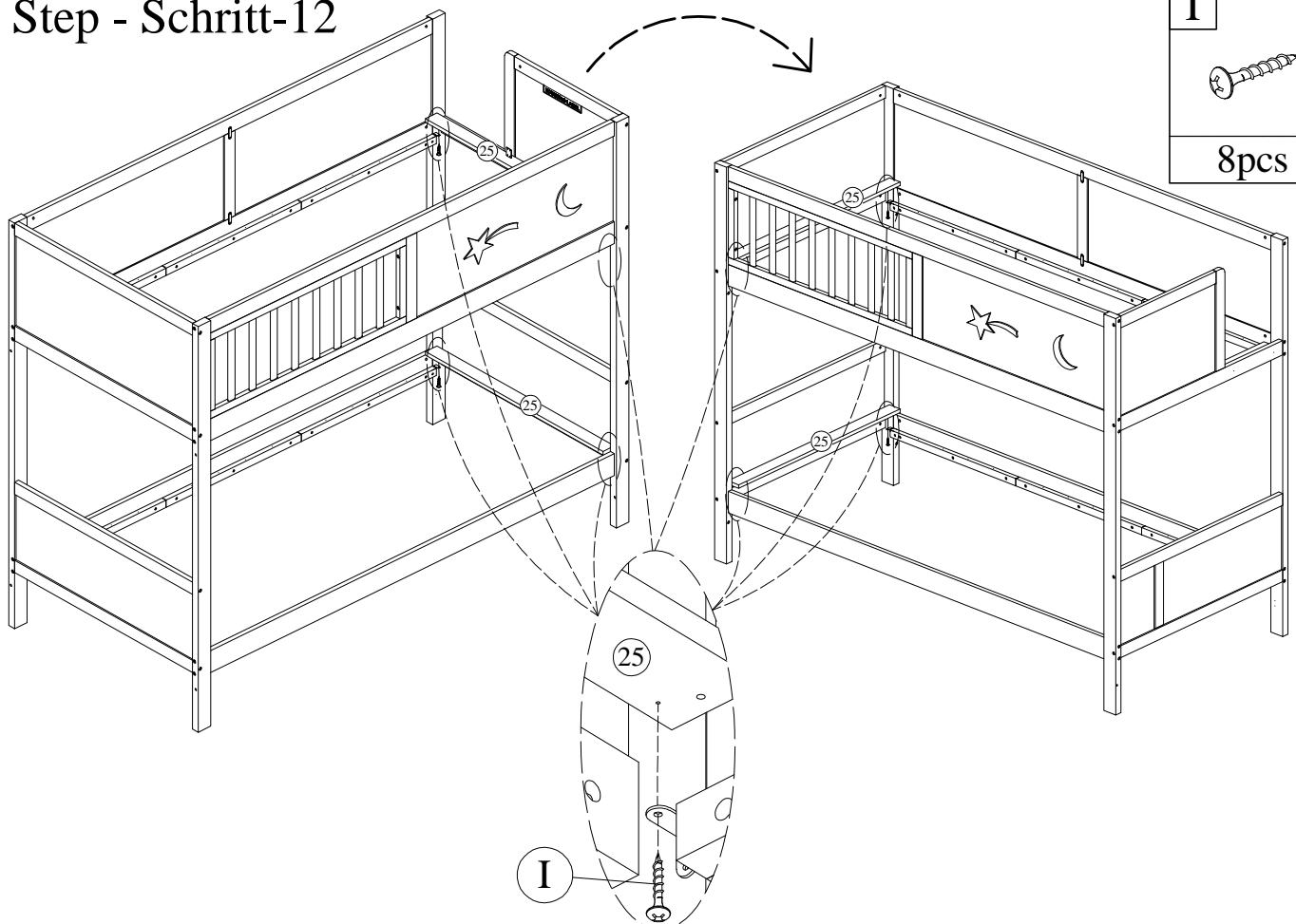

Step - Schritt-13

J

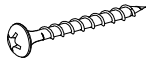

28pcs

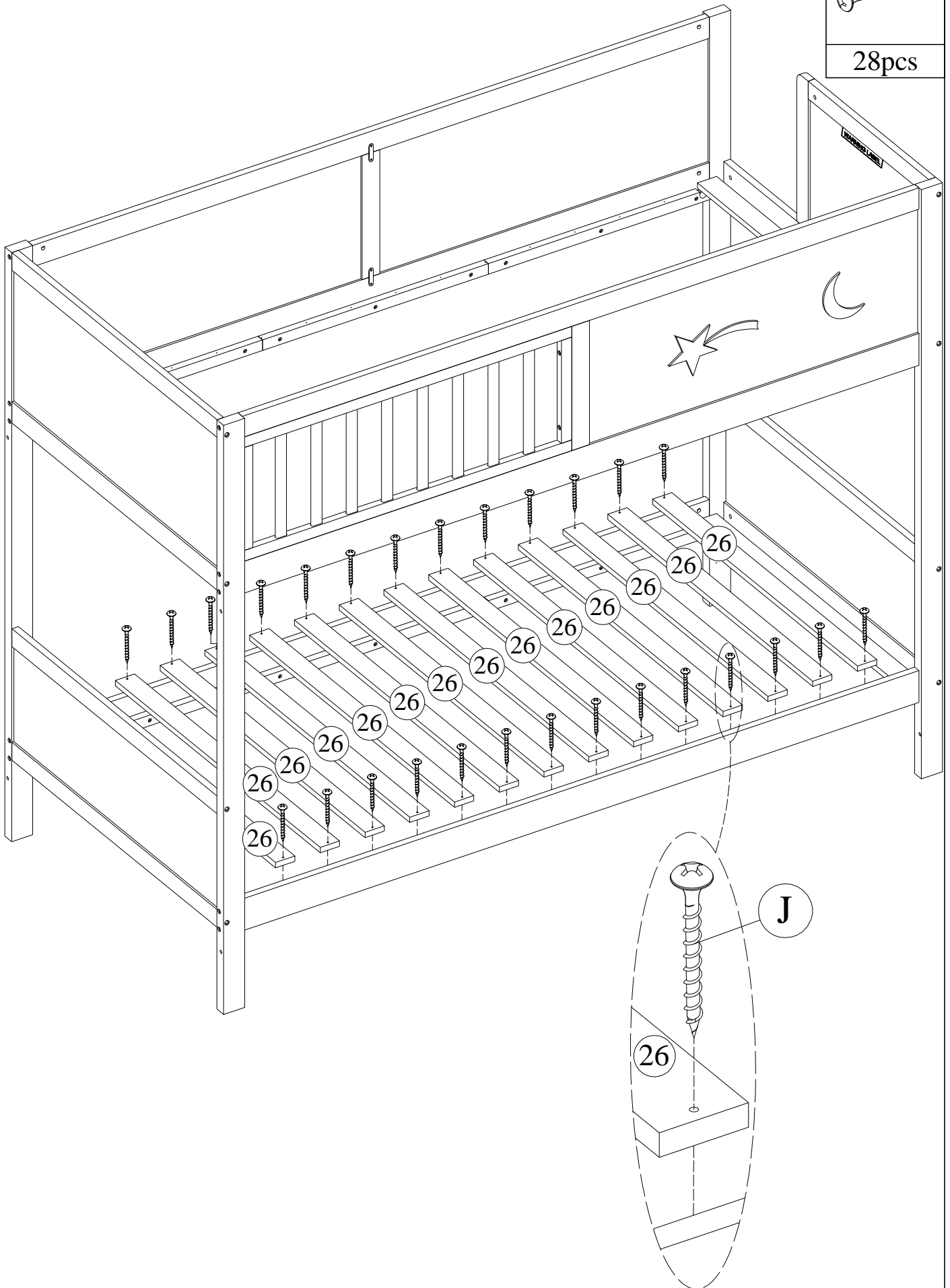

Step - Schritt-14



K

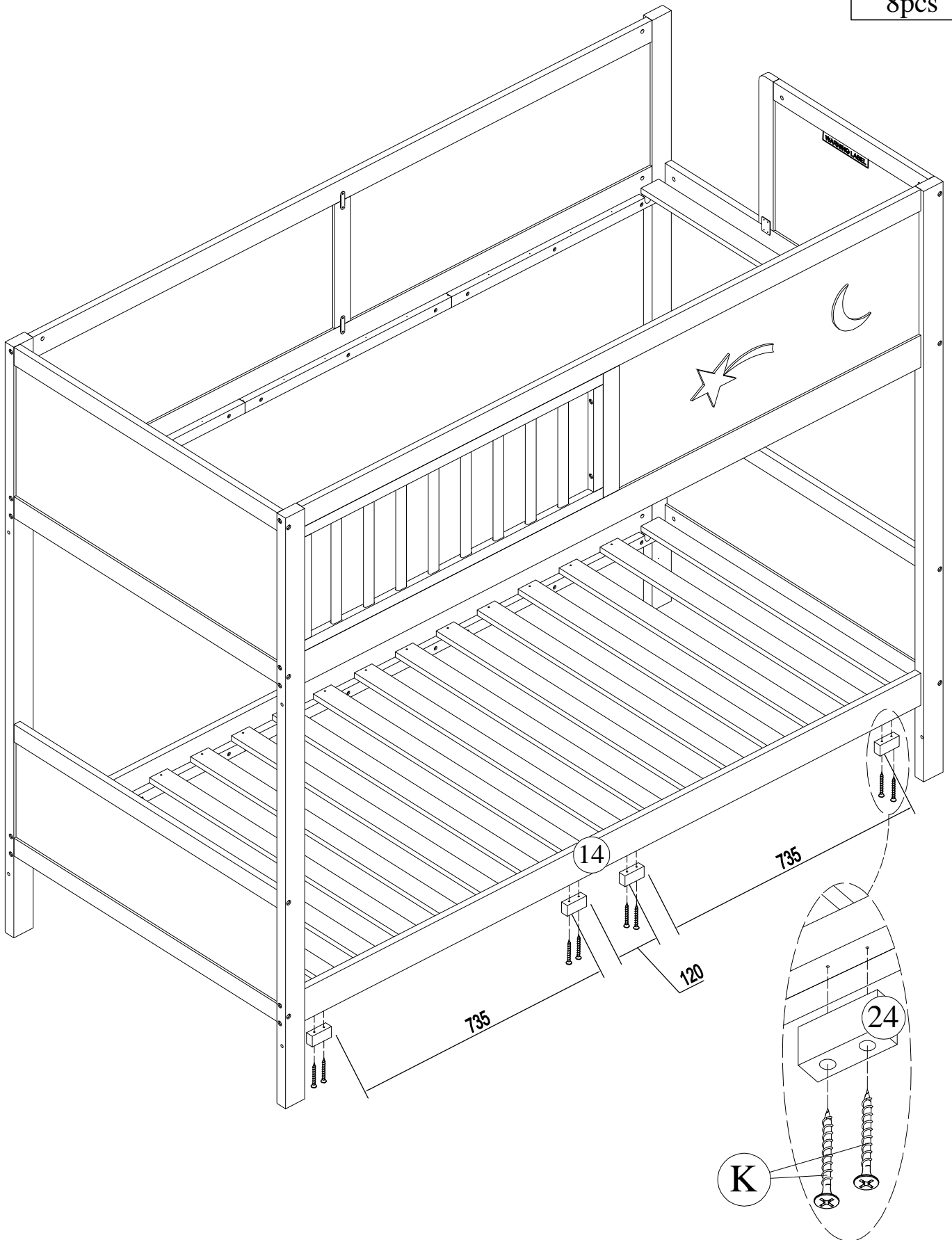

8pcs



Step - Schritt-17

M	C
	
2pcs	2pcs

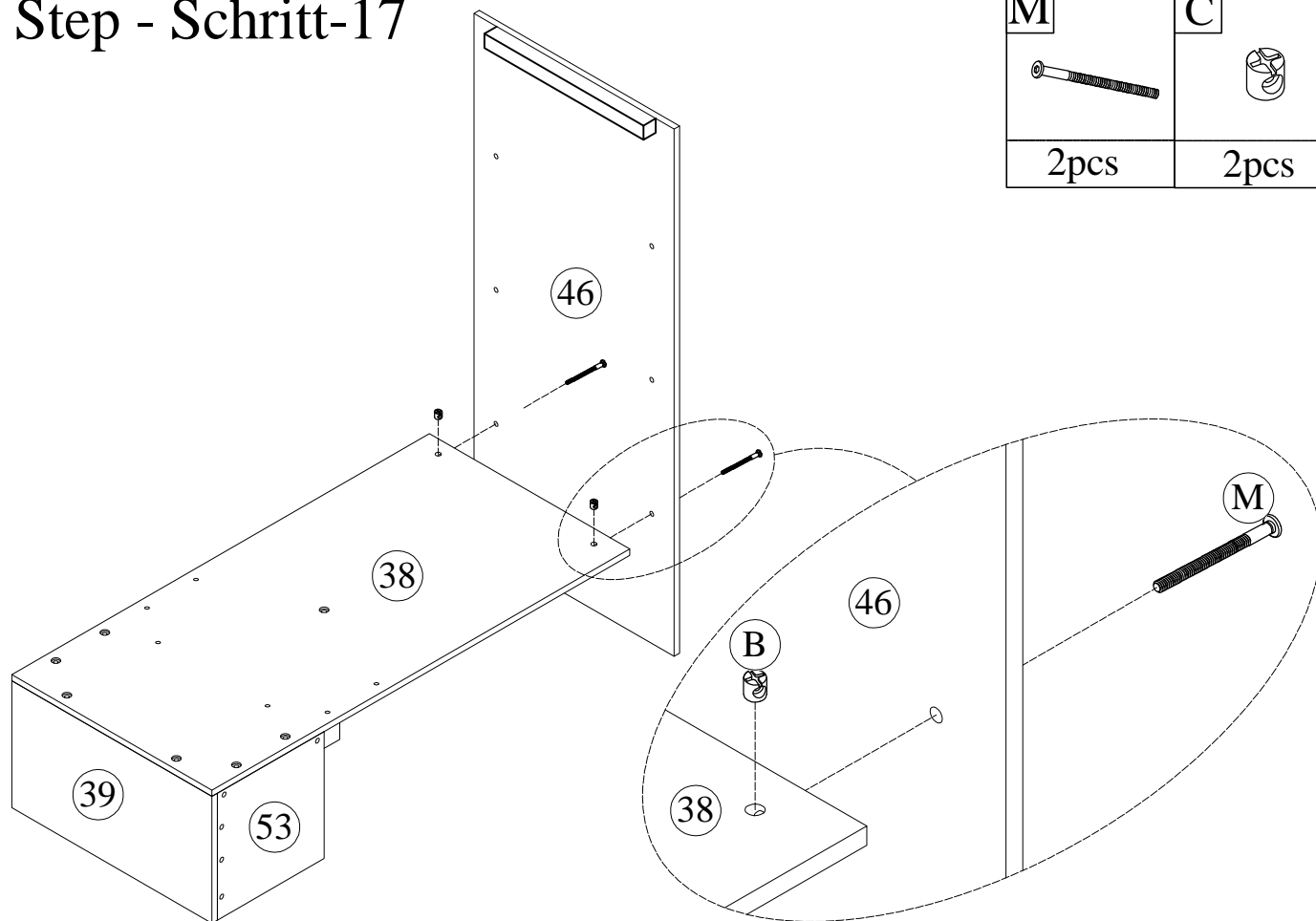

Step - Schritt-18

R

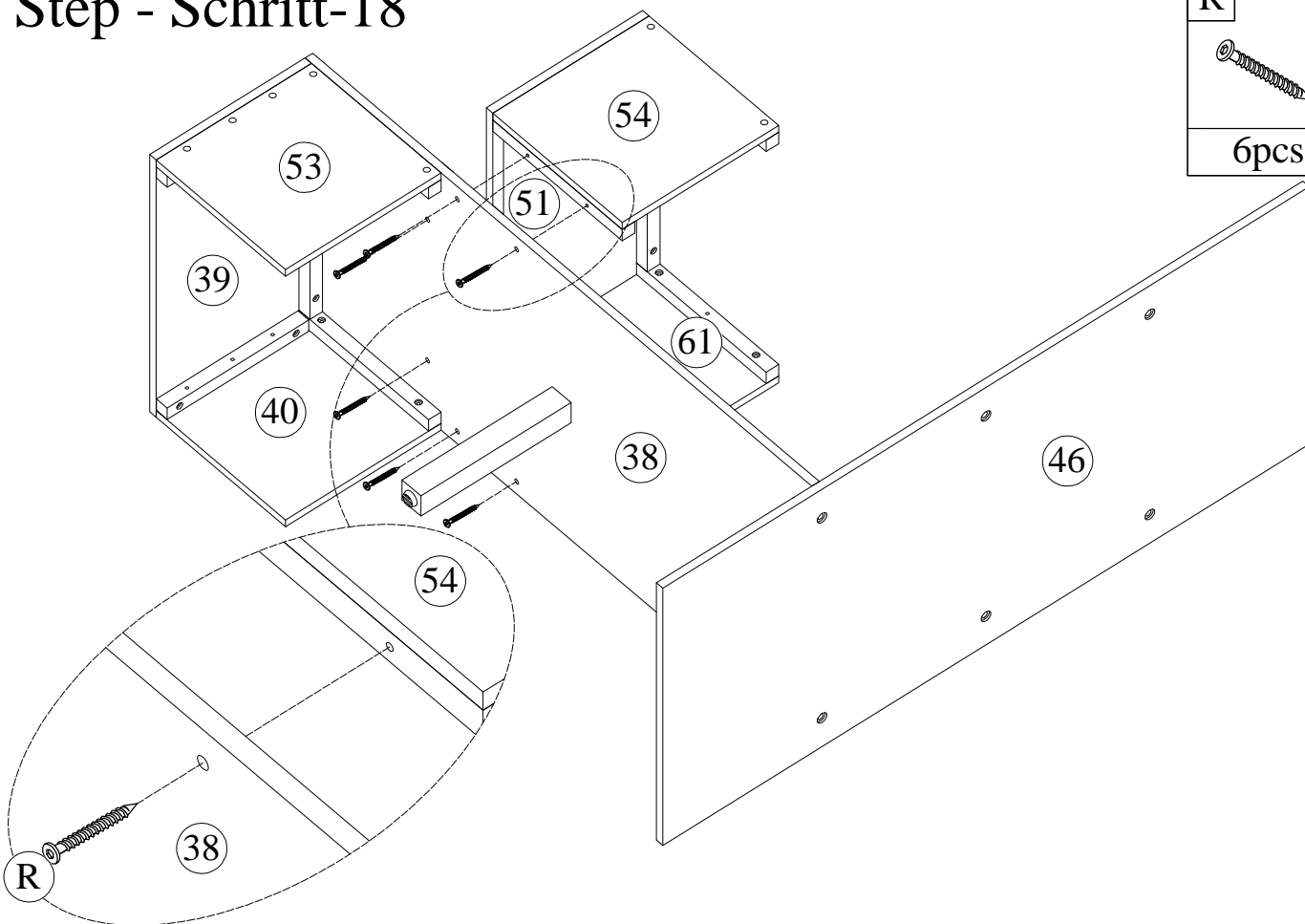
6pcs

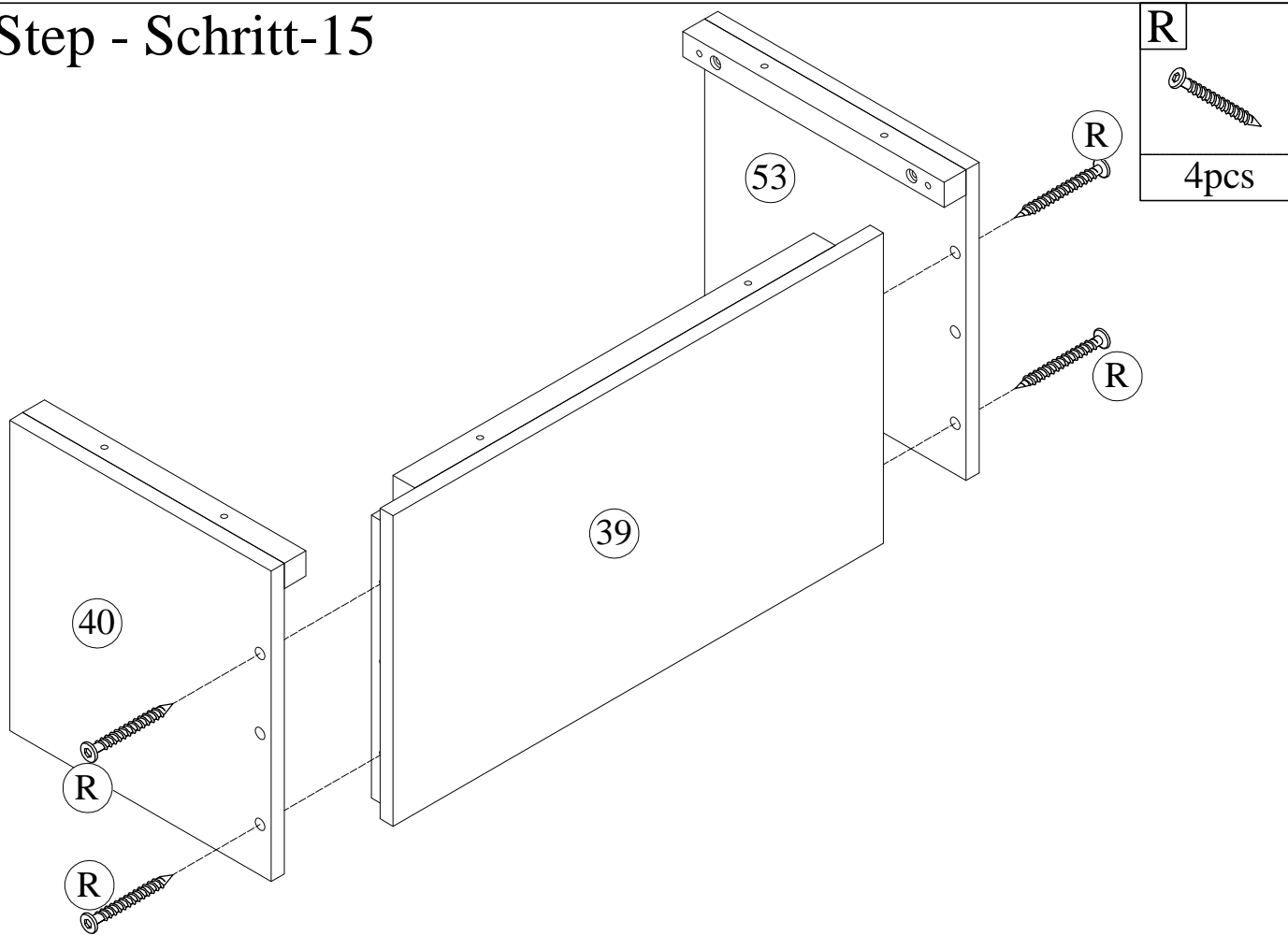

Step - Schritt-15

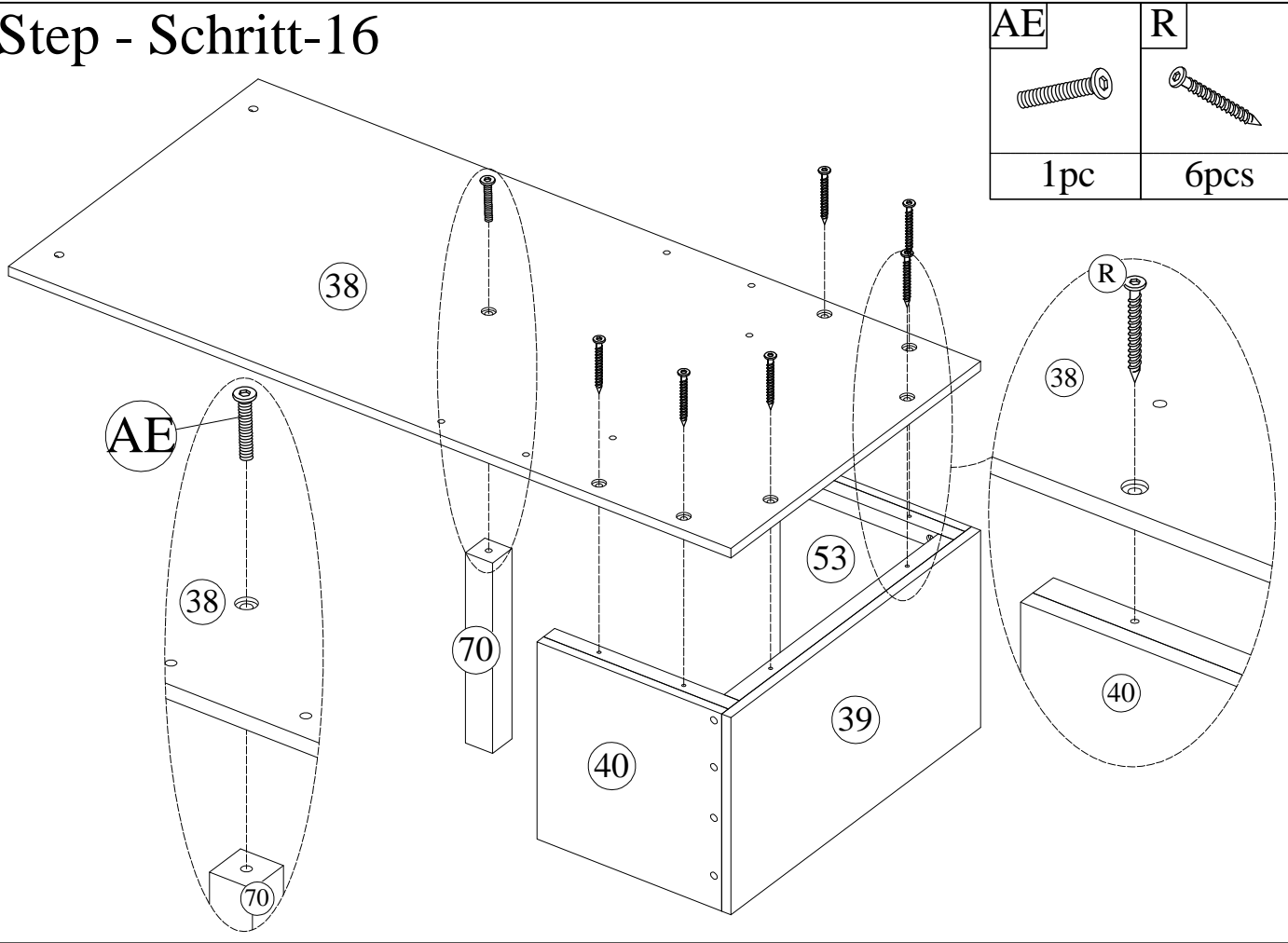

Step - Schritt-16



Step - Schritt-19

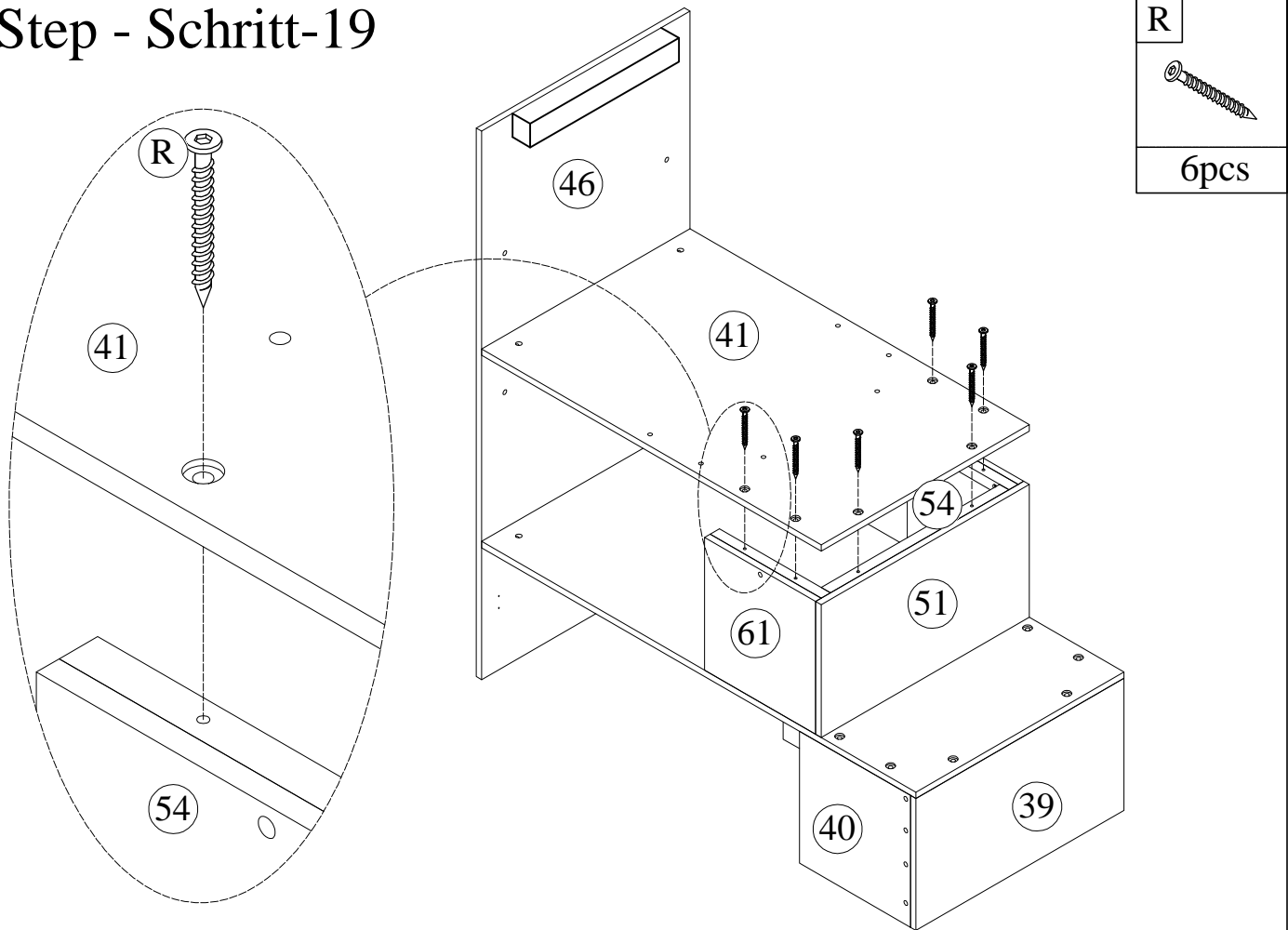

Step - Schritt-20

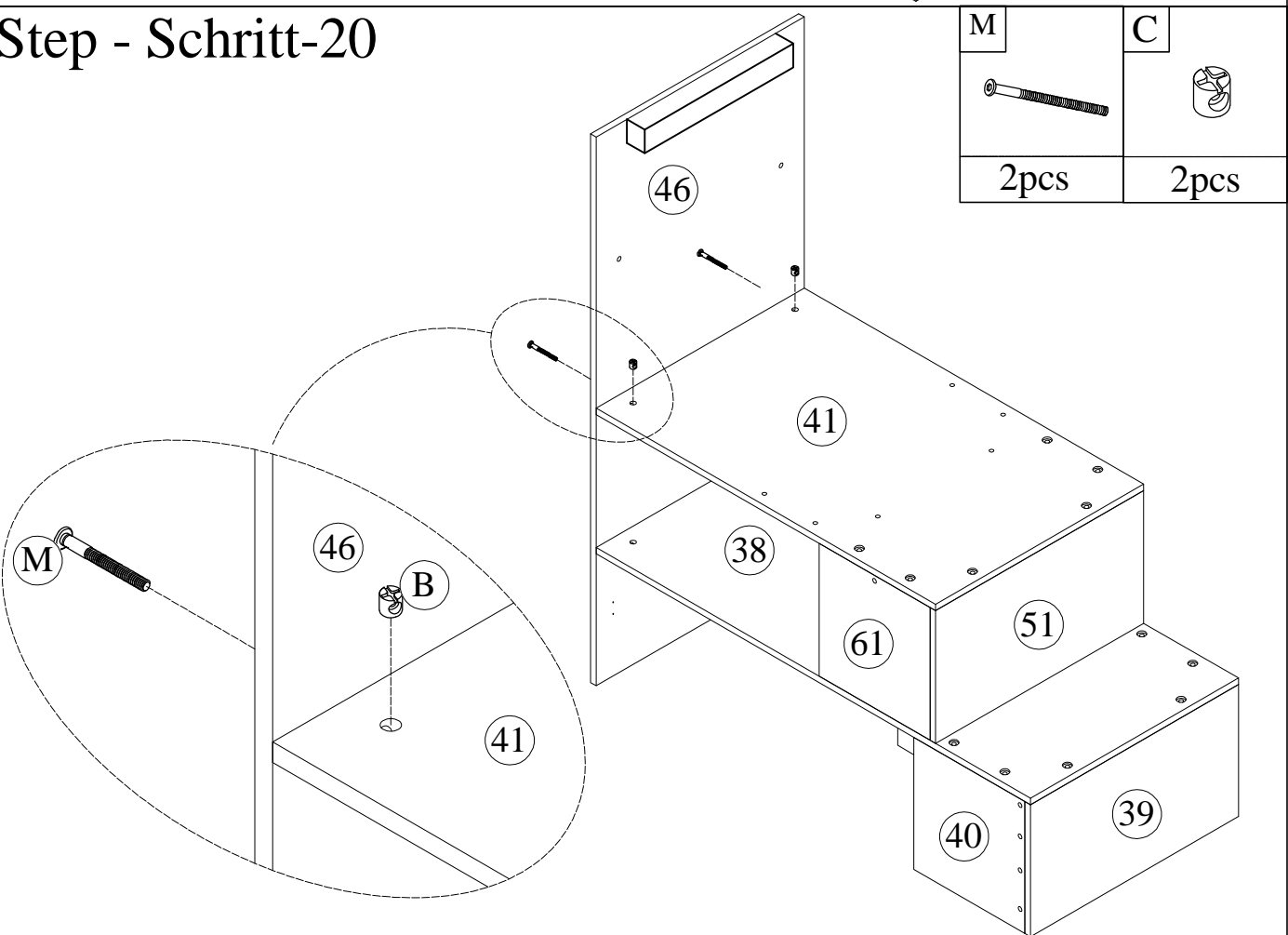

Step - Schritt-21

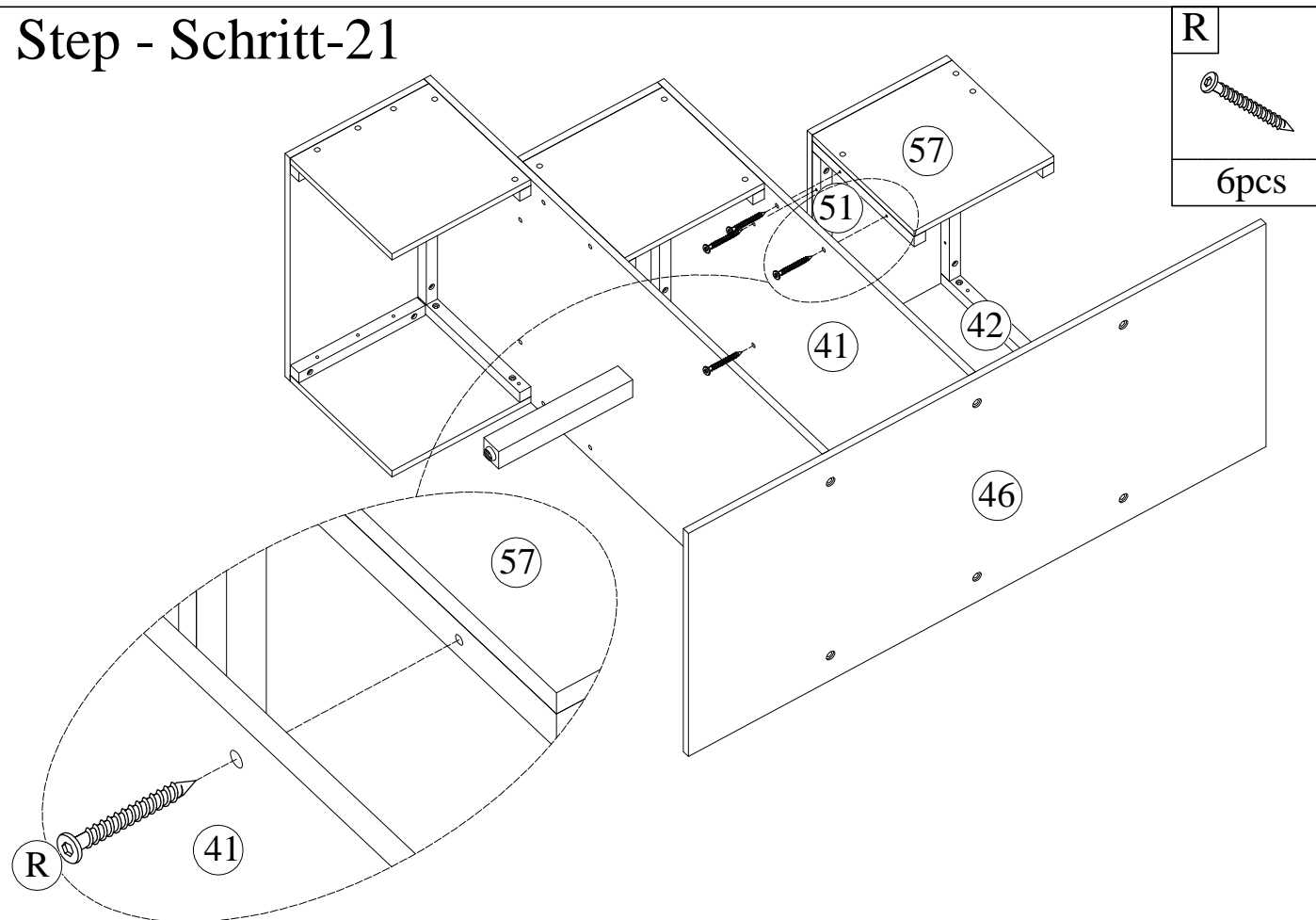

Step - Schritt-22

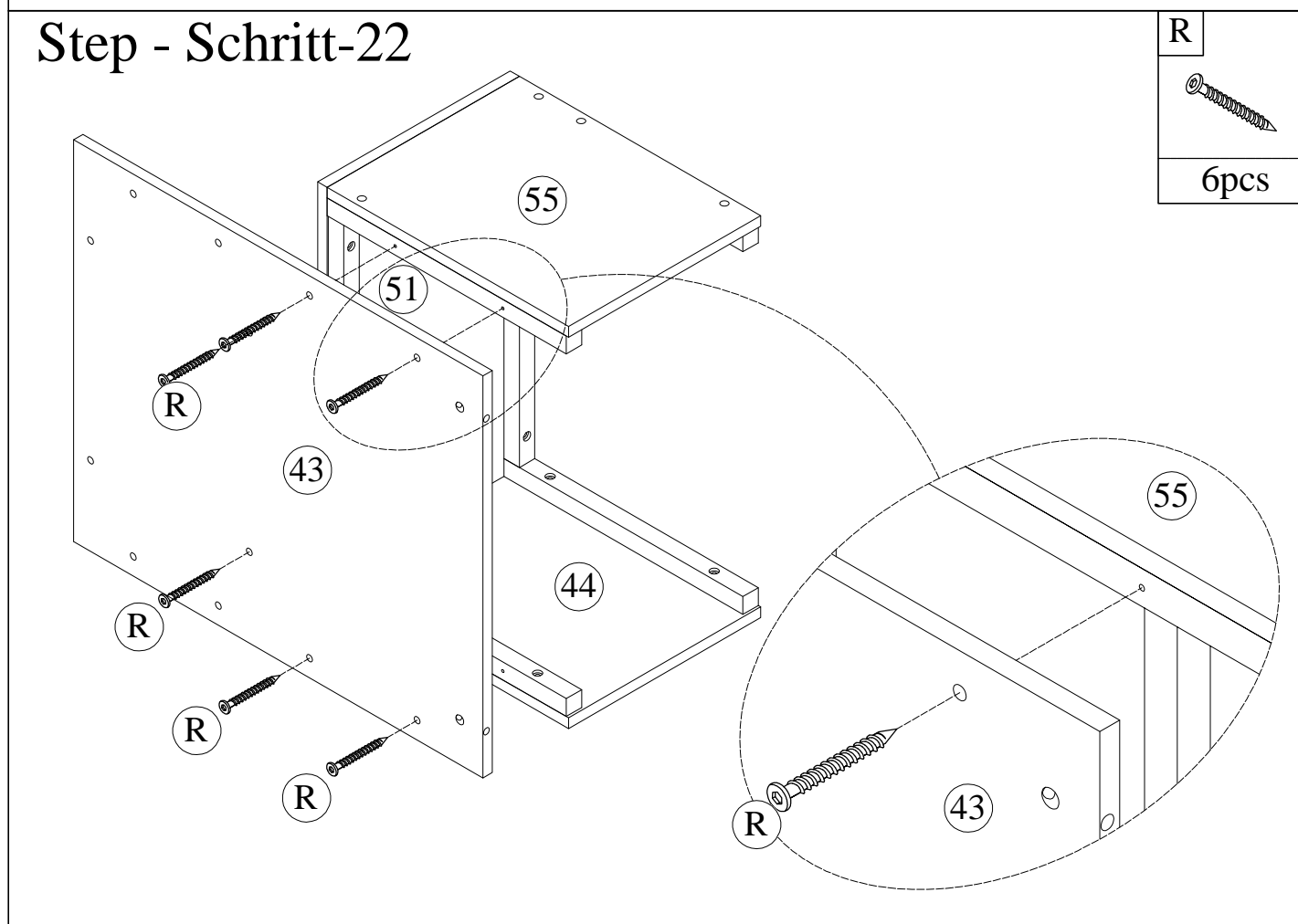

Step - Schritt-23

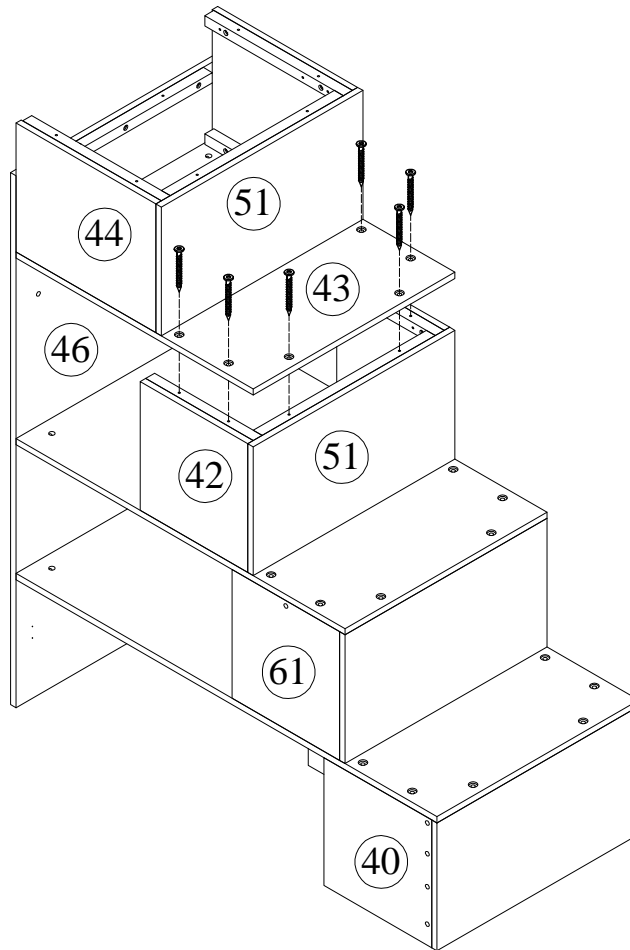

R



6pcs

Step - Schritt-24

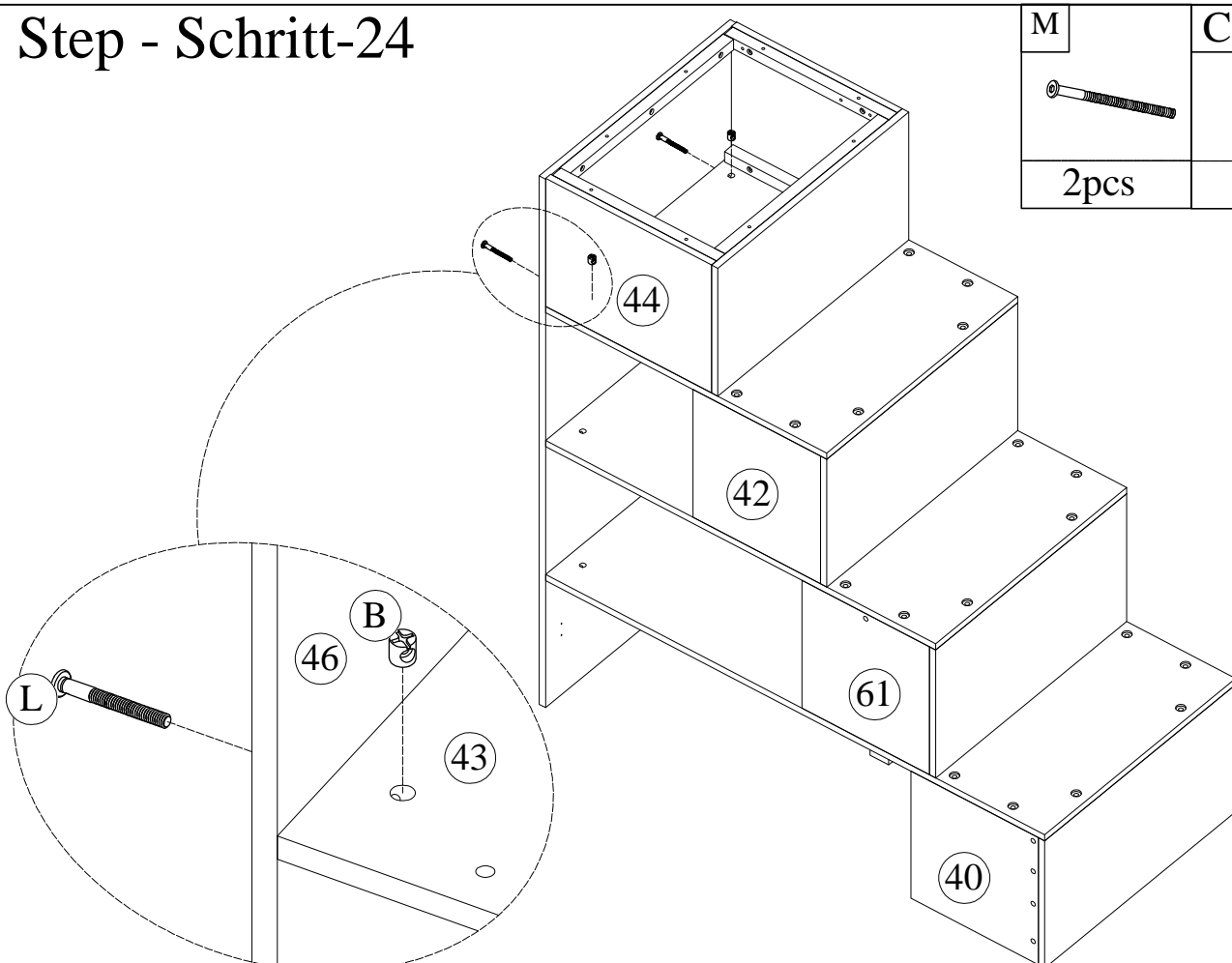

M



2pcs

C



2pcs

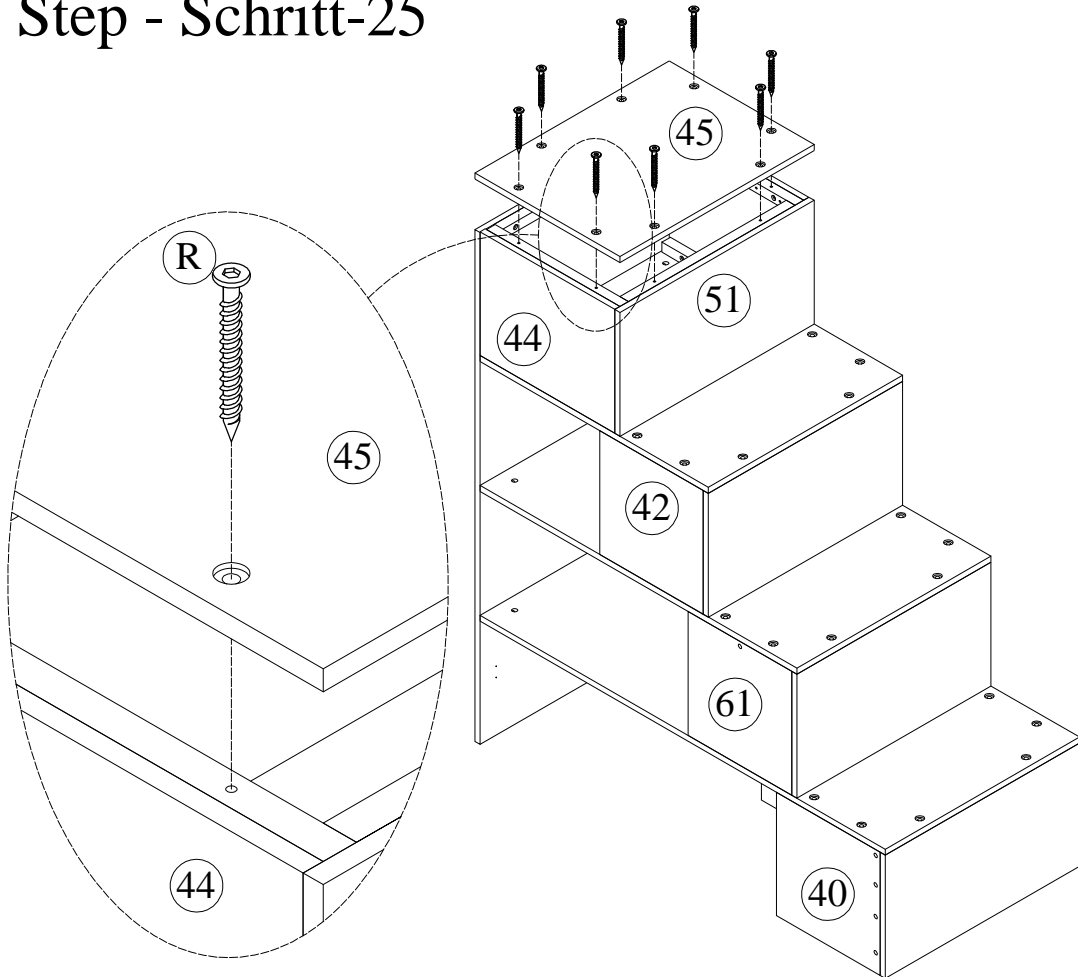

Step - Schritt-25

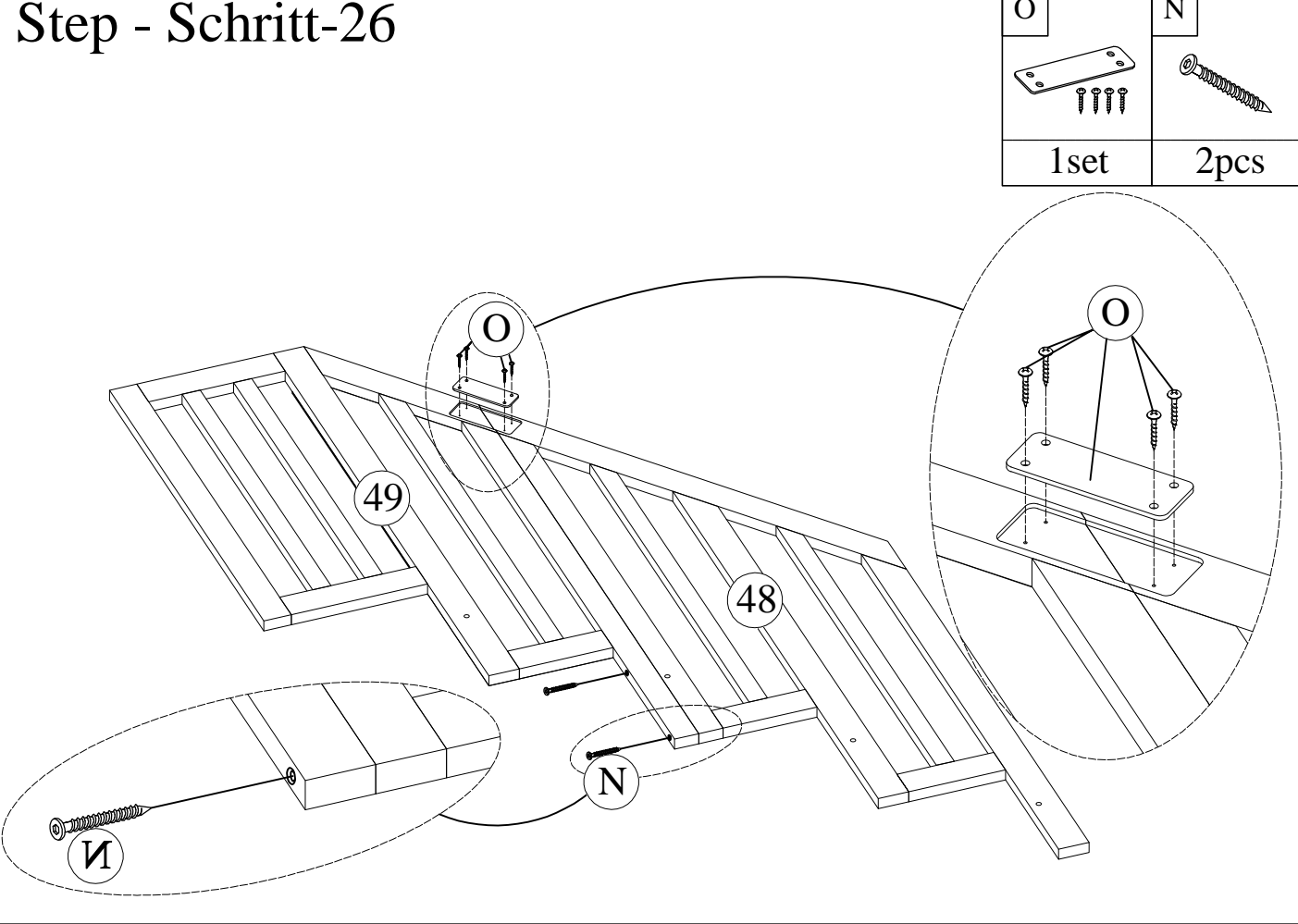

R

8pcs

Step - Schritt-26





O	N
 	
1set	2pcs

Step - Schritt-27

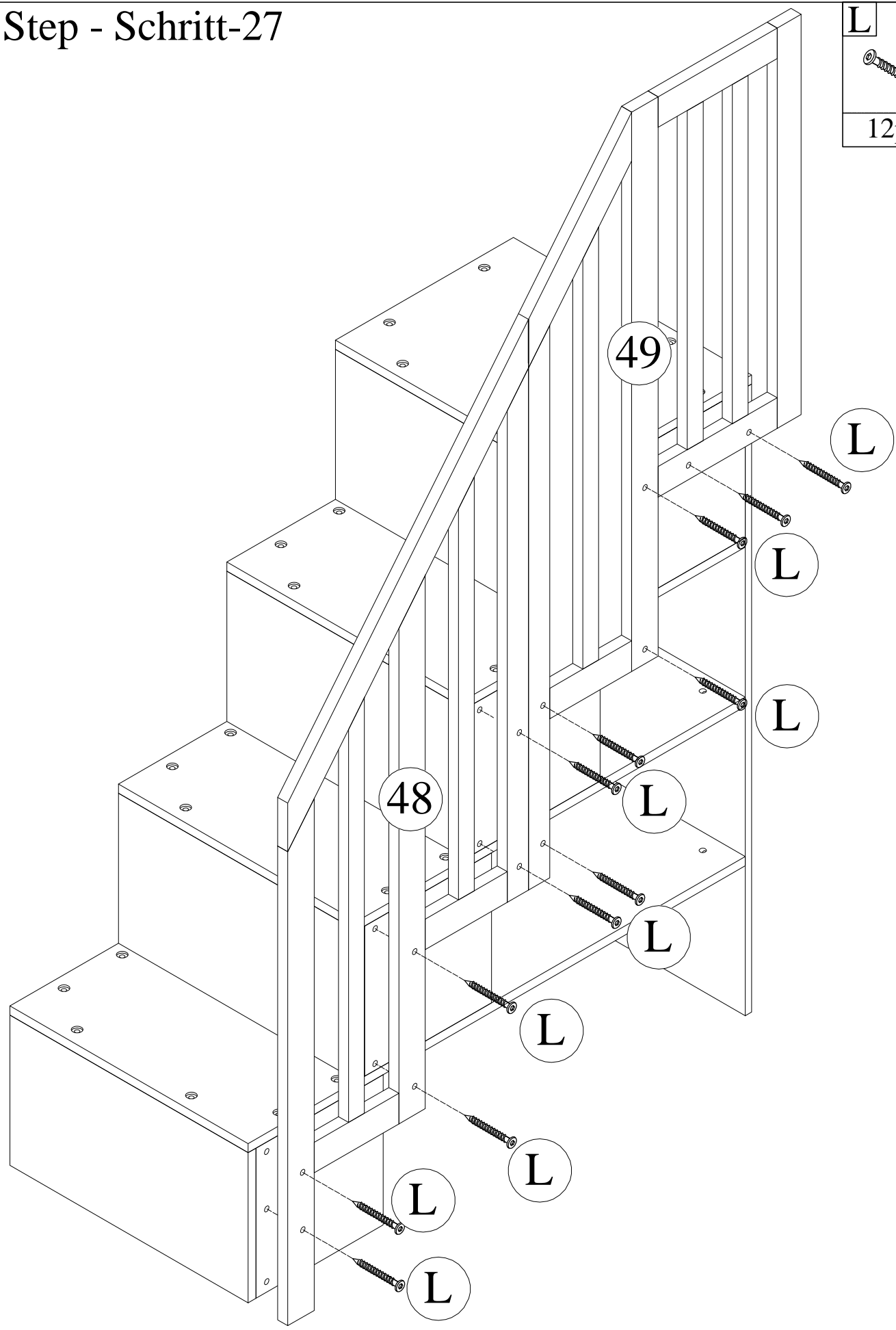
L
12pcs



Step - Schritt-28

L

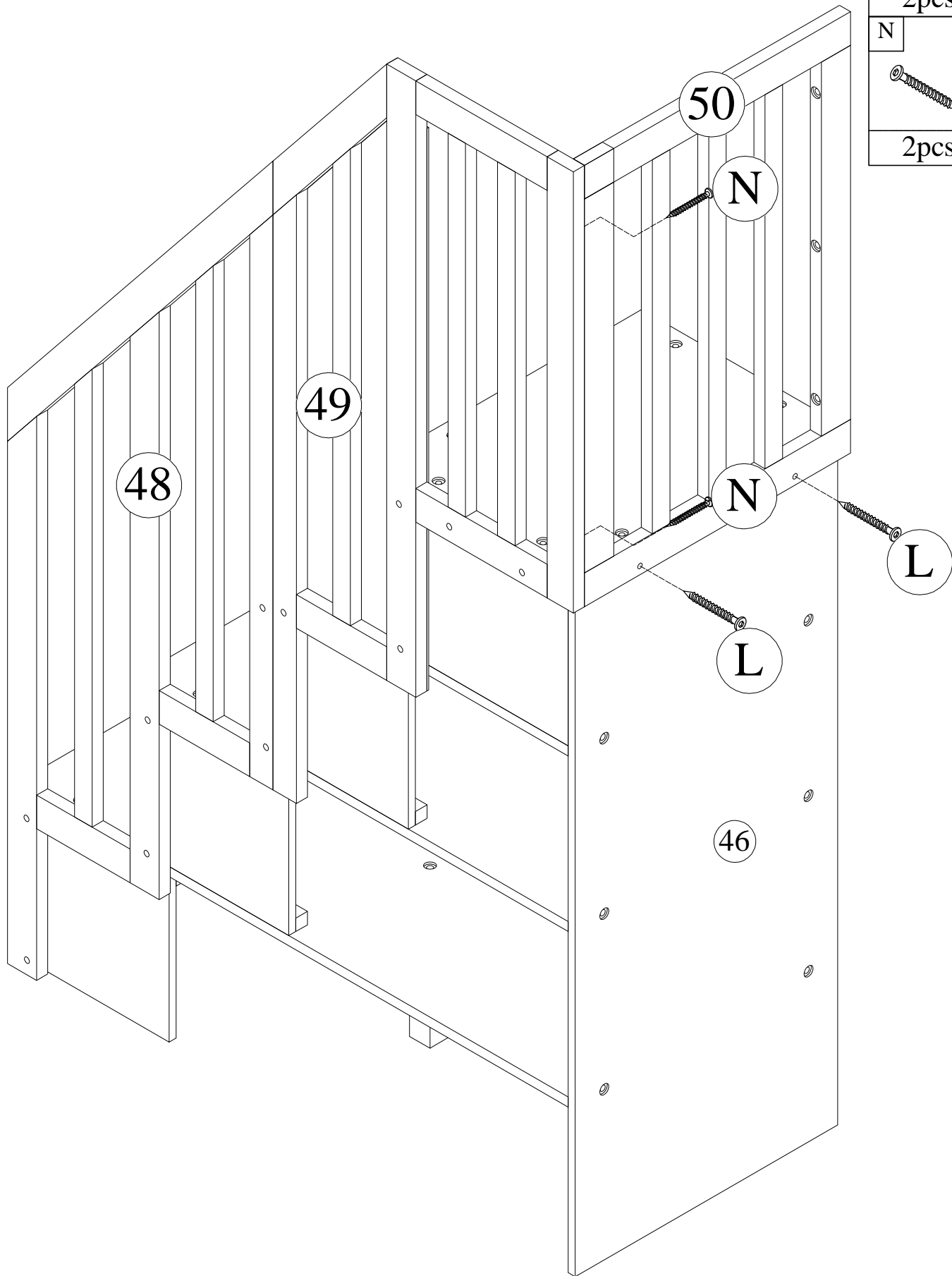
2pcs
N

2pcs



Step - Schritt-29

P



2pcs

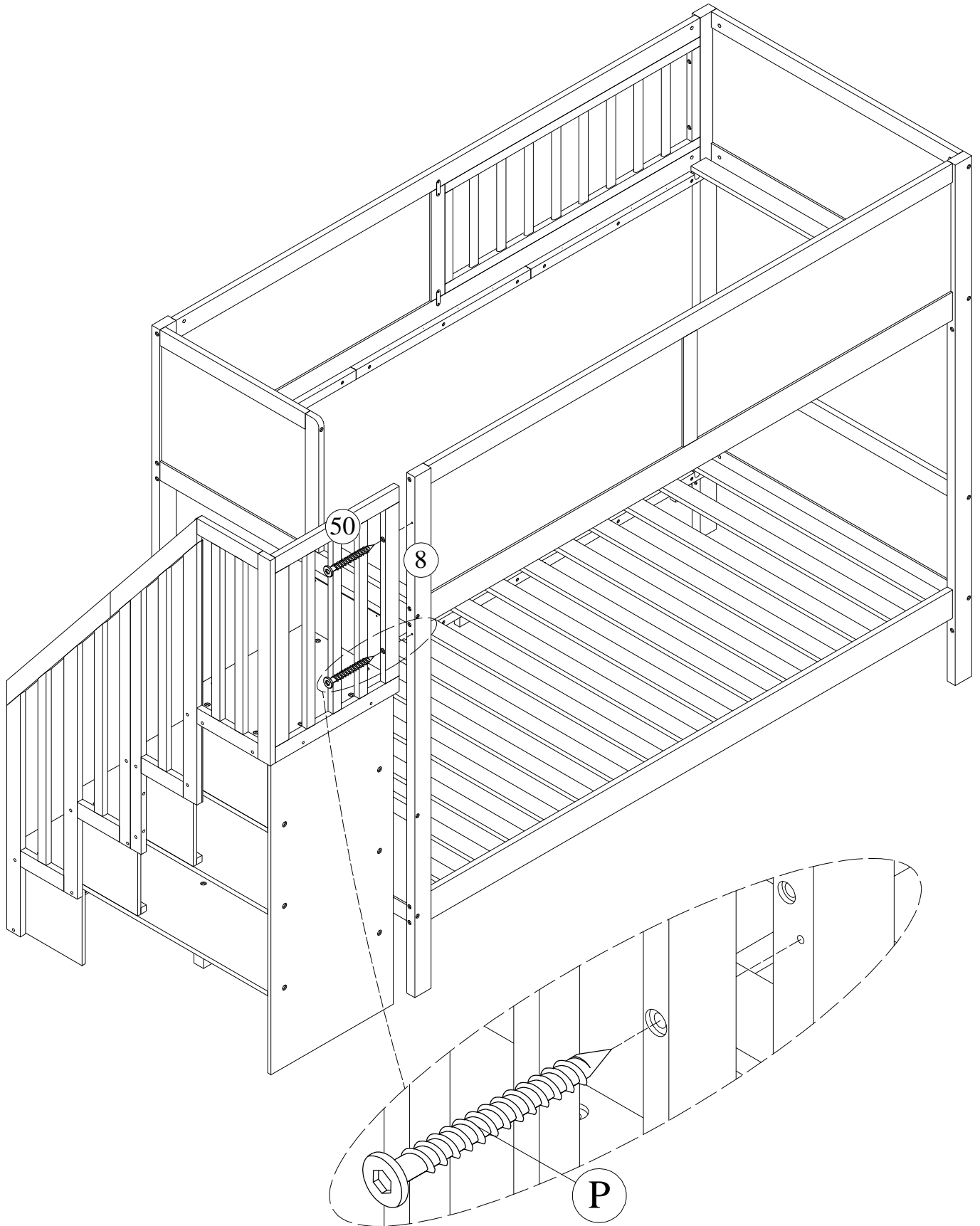

Step - Schritt-30

I

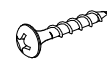

2pcs

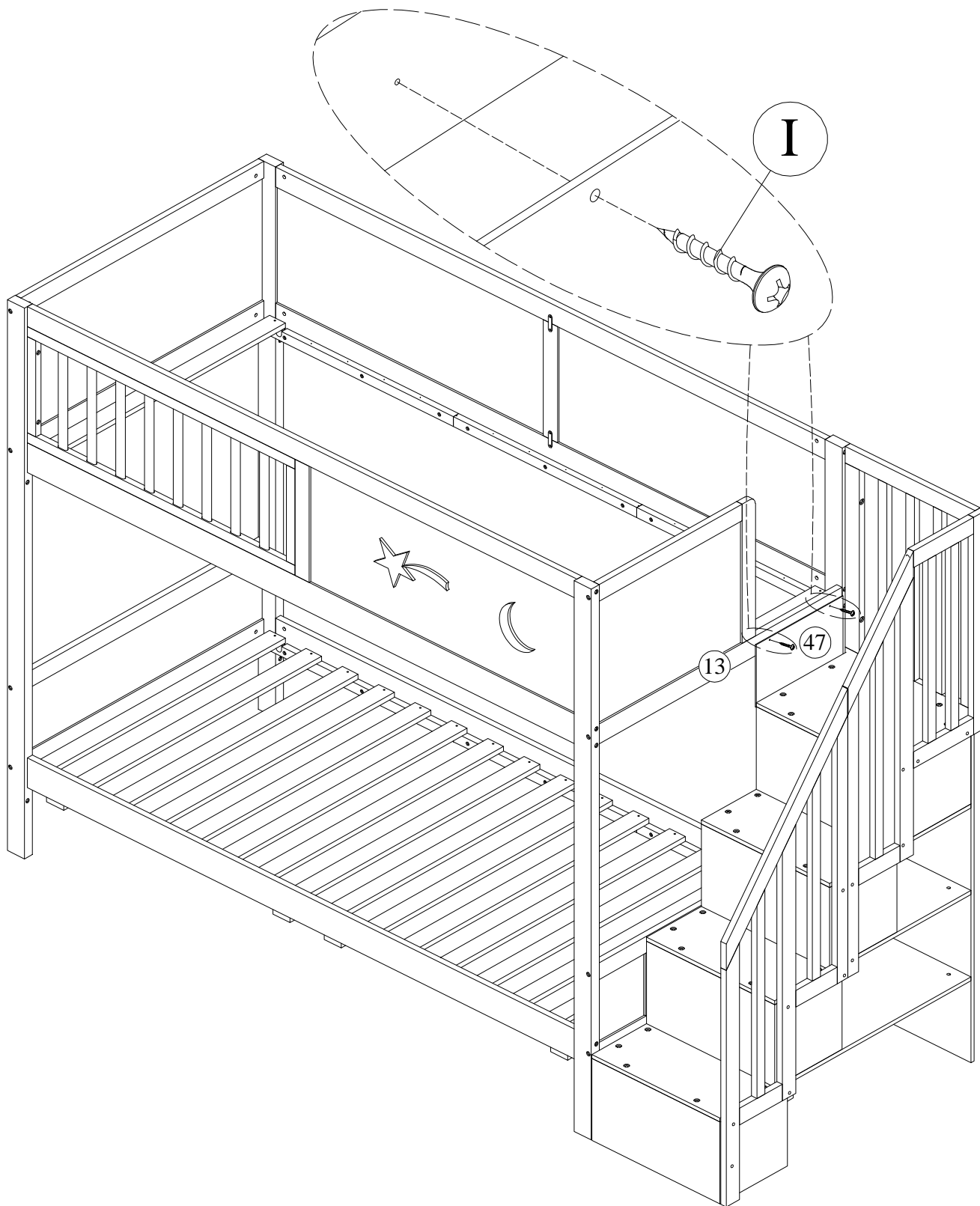

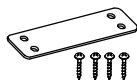

Step - Schritt-31

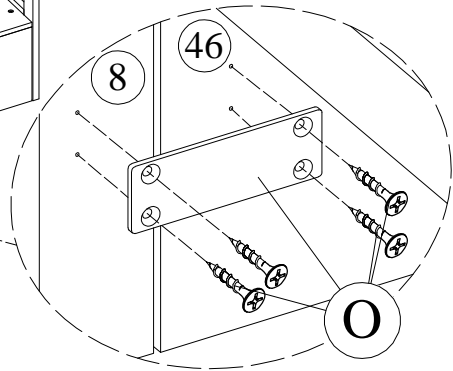
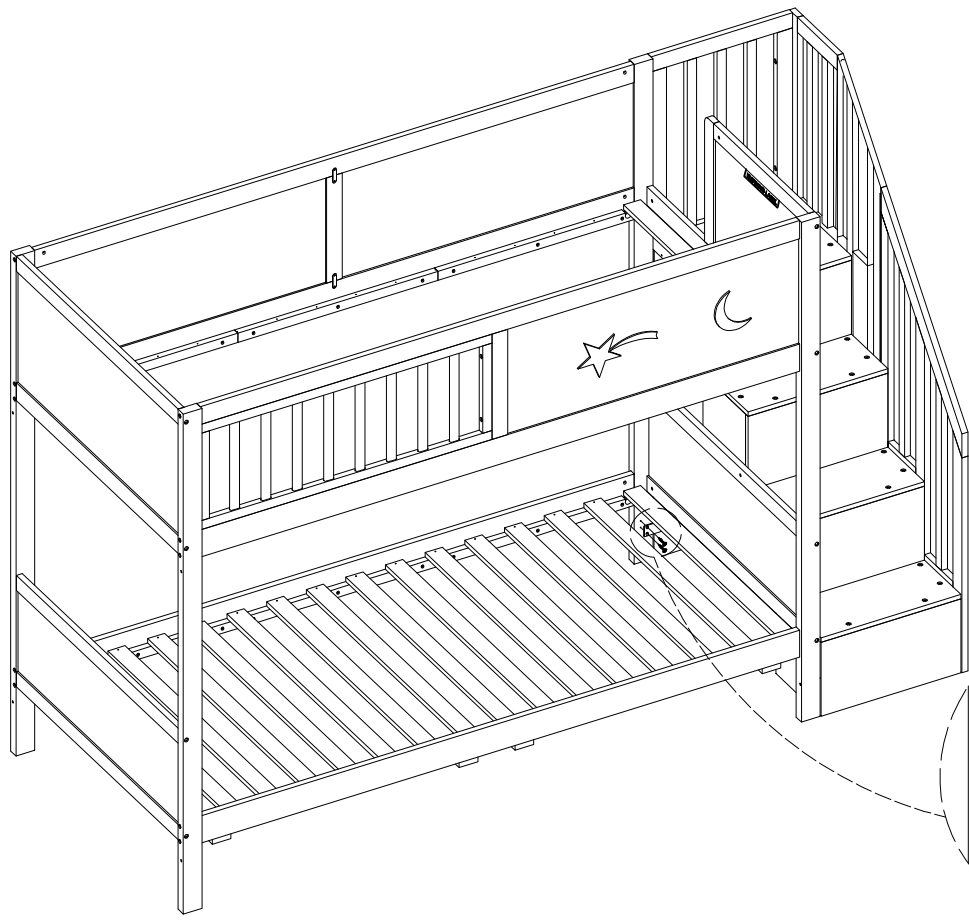
O

1set

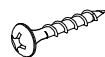

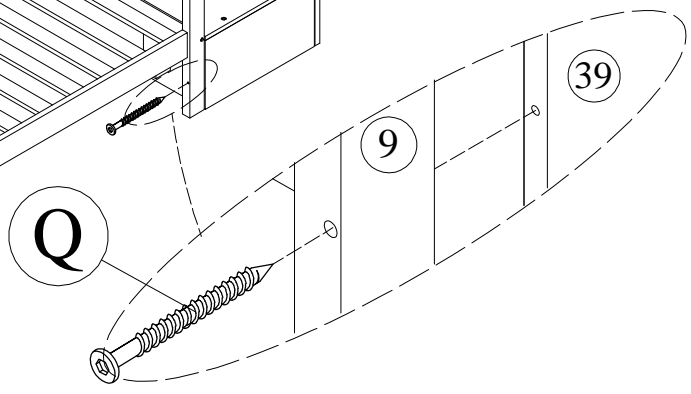
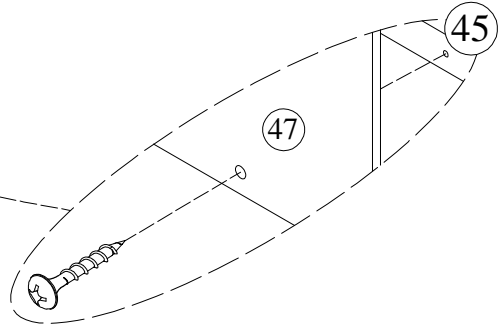
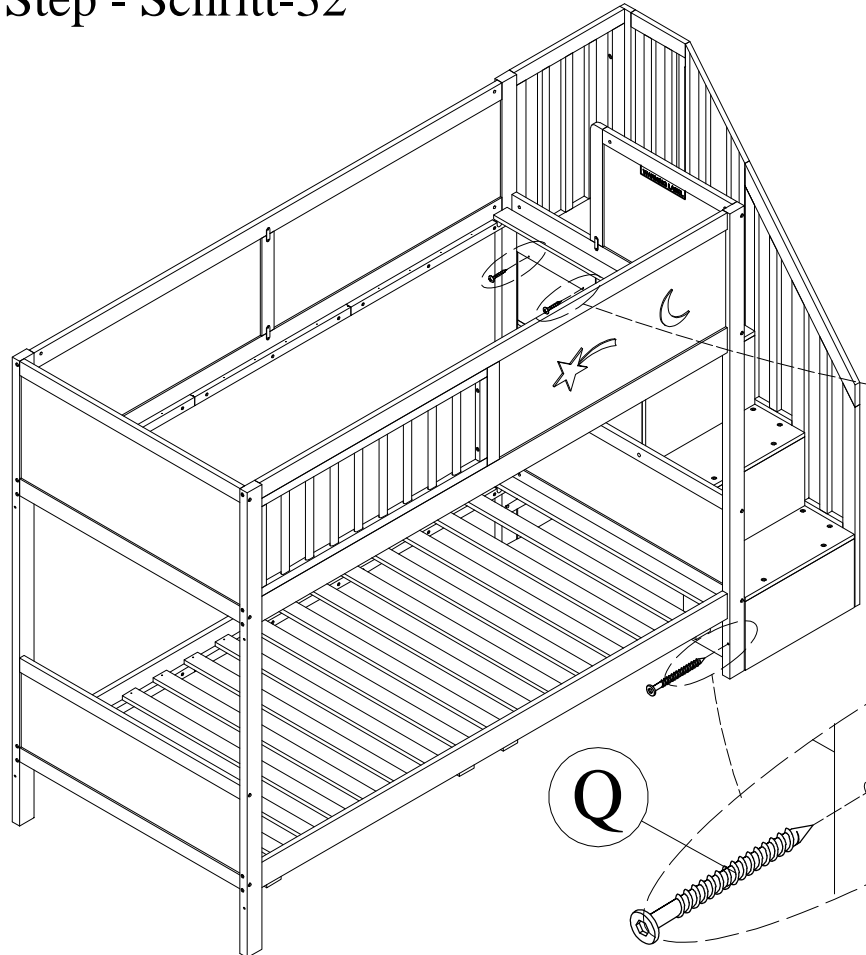

Step - Schritt-32

I	Q
	
2pcs	1pc

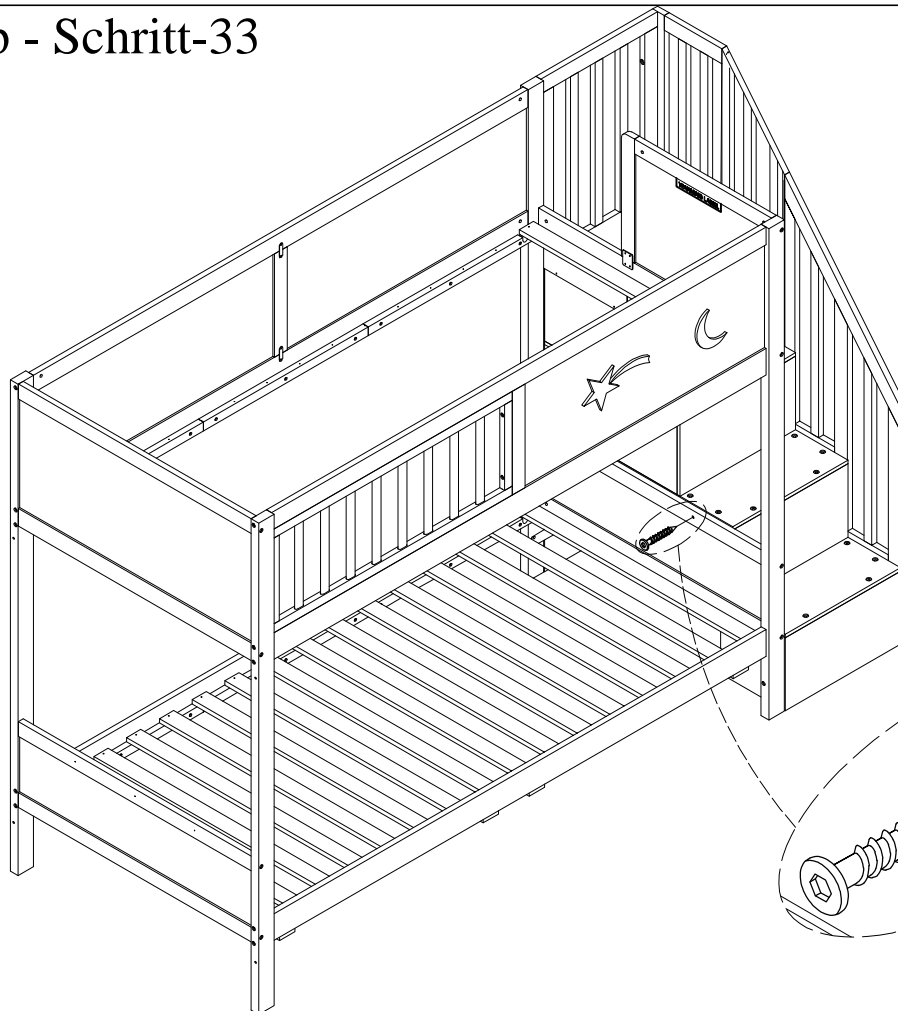

Step - Schritt-33



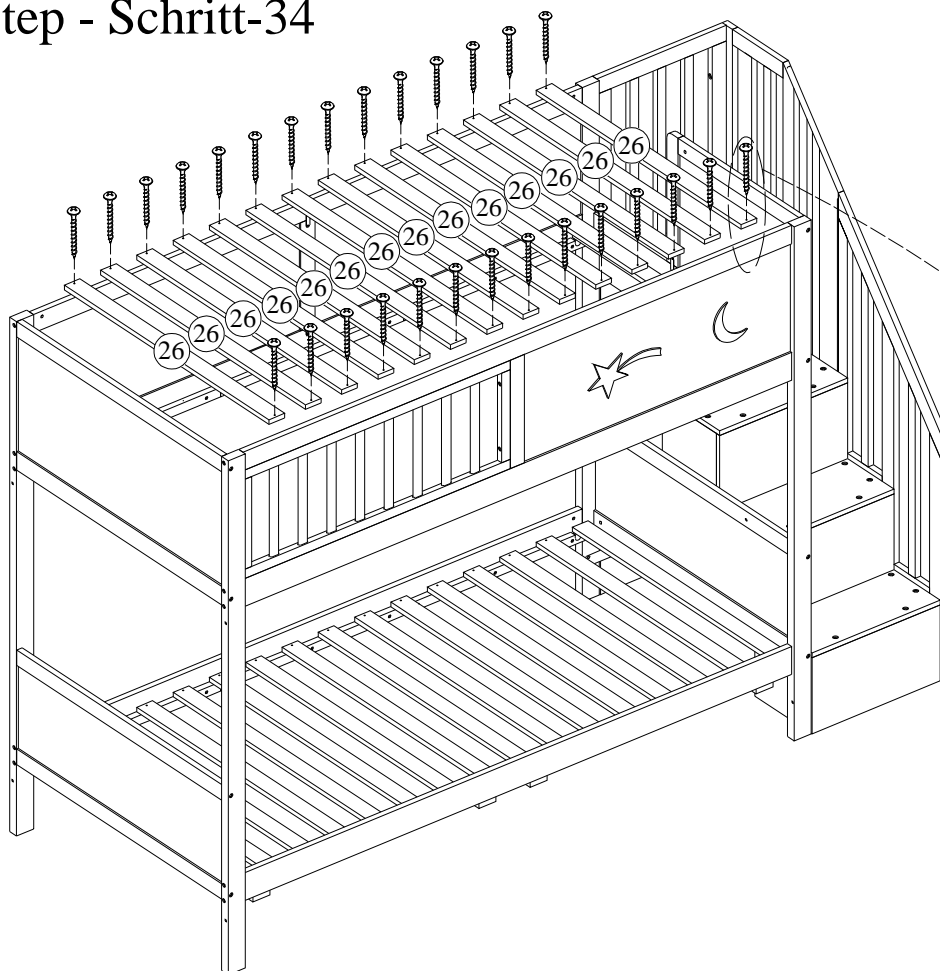

L

1pc

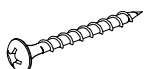
Step - Schritt-34



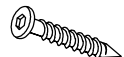

J

28pcs

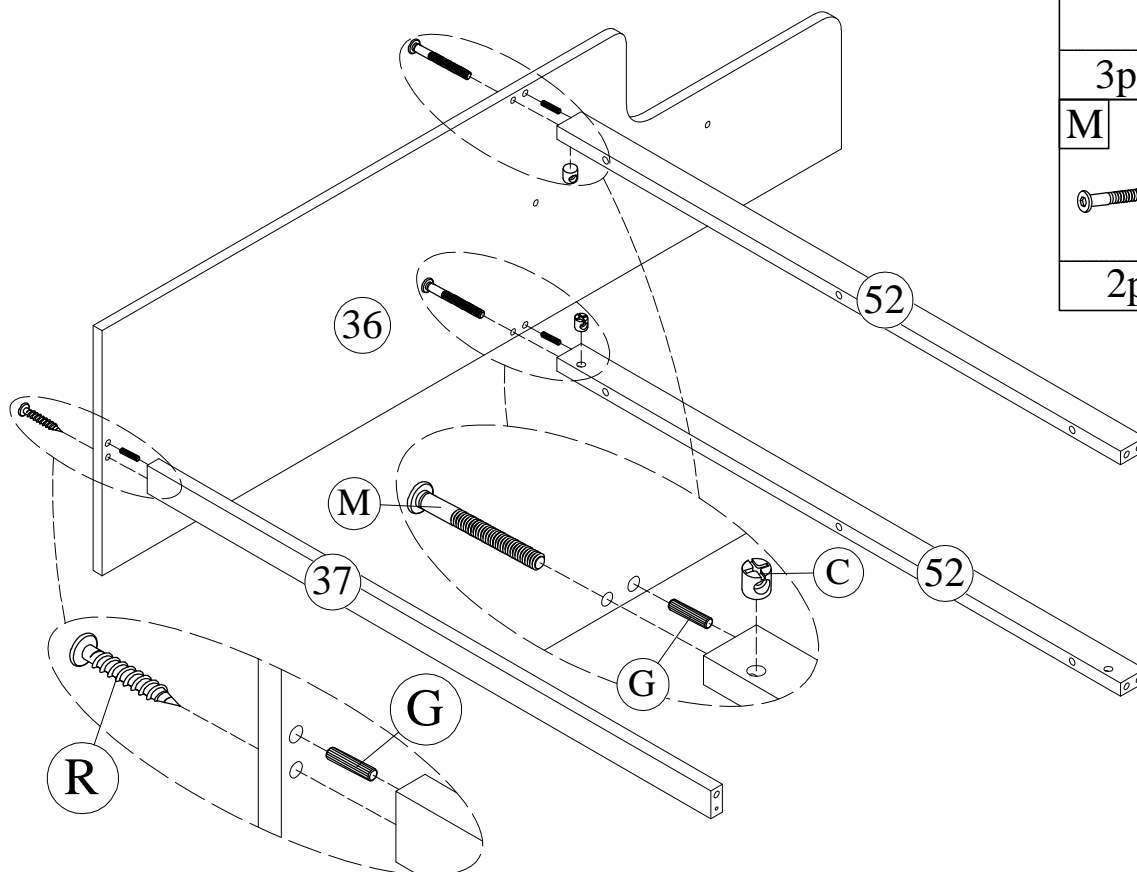
Step - Schritt-35

G 	R 
3pcs	1pc
M 	C 
2pcs	2pcs





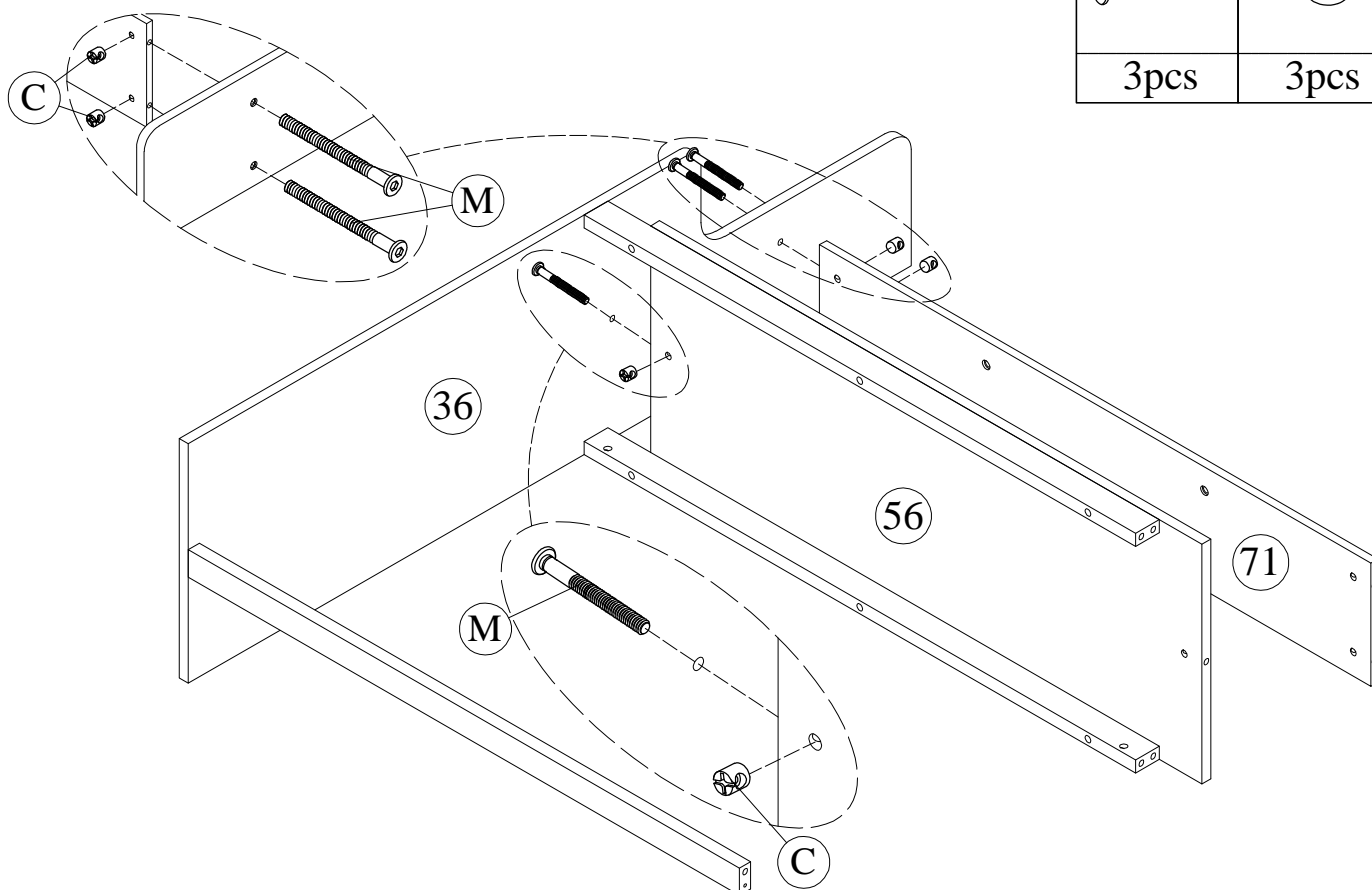

Step - Schritt-36

M 	C 
3pcs	3pcs

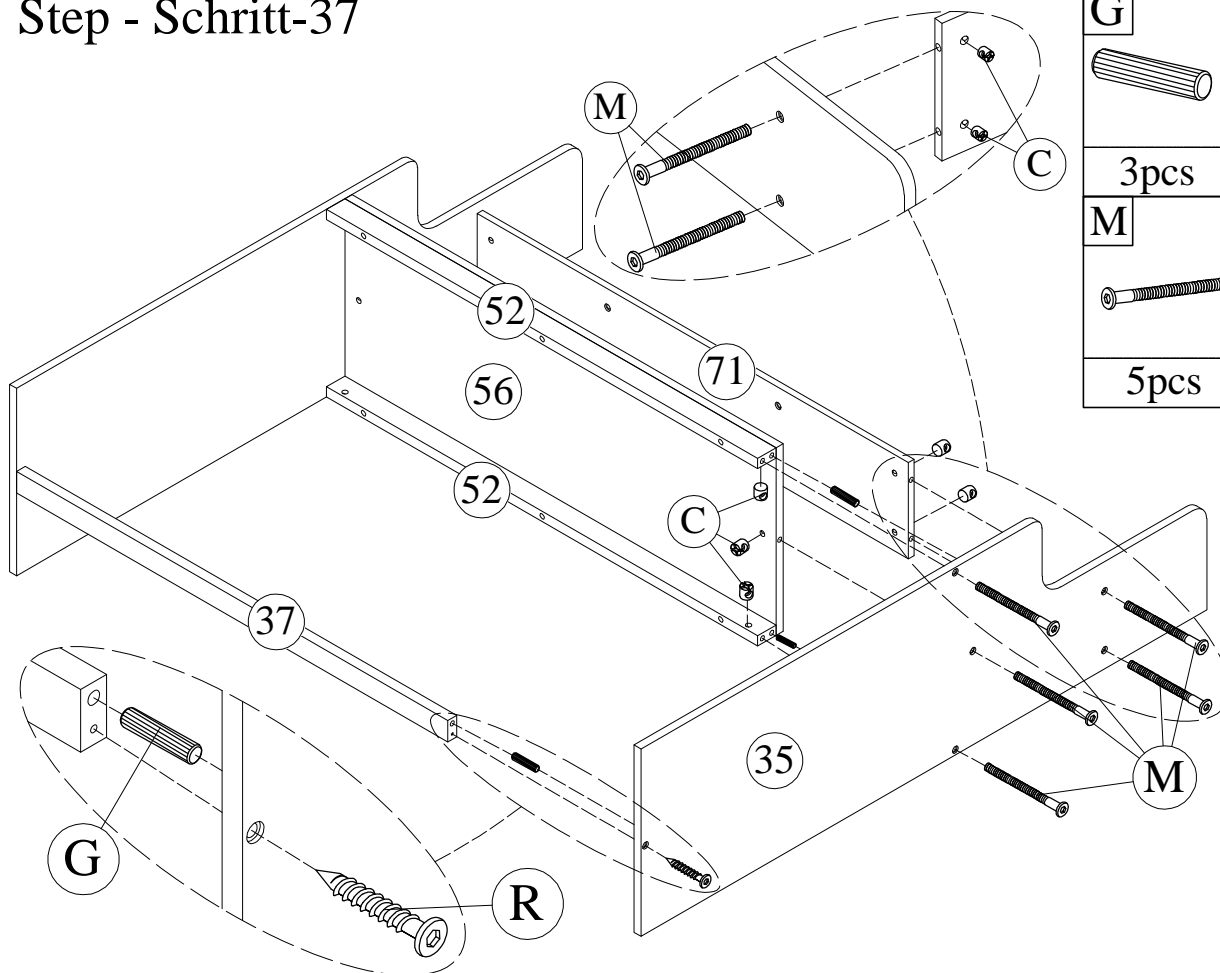

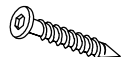

Step - Schritt-37



G 	R 
3pcs	1pc
M 	C 
5pcs	5pcs

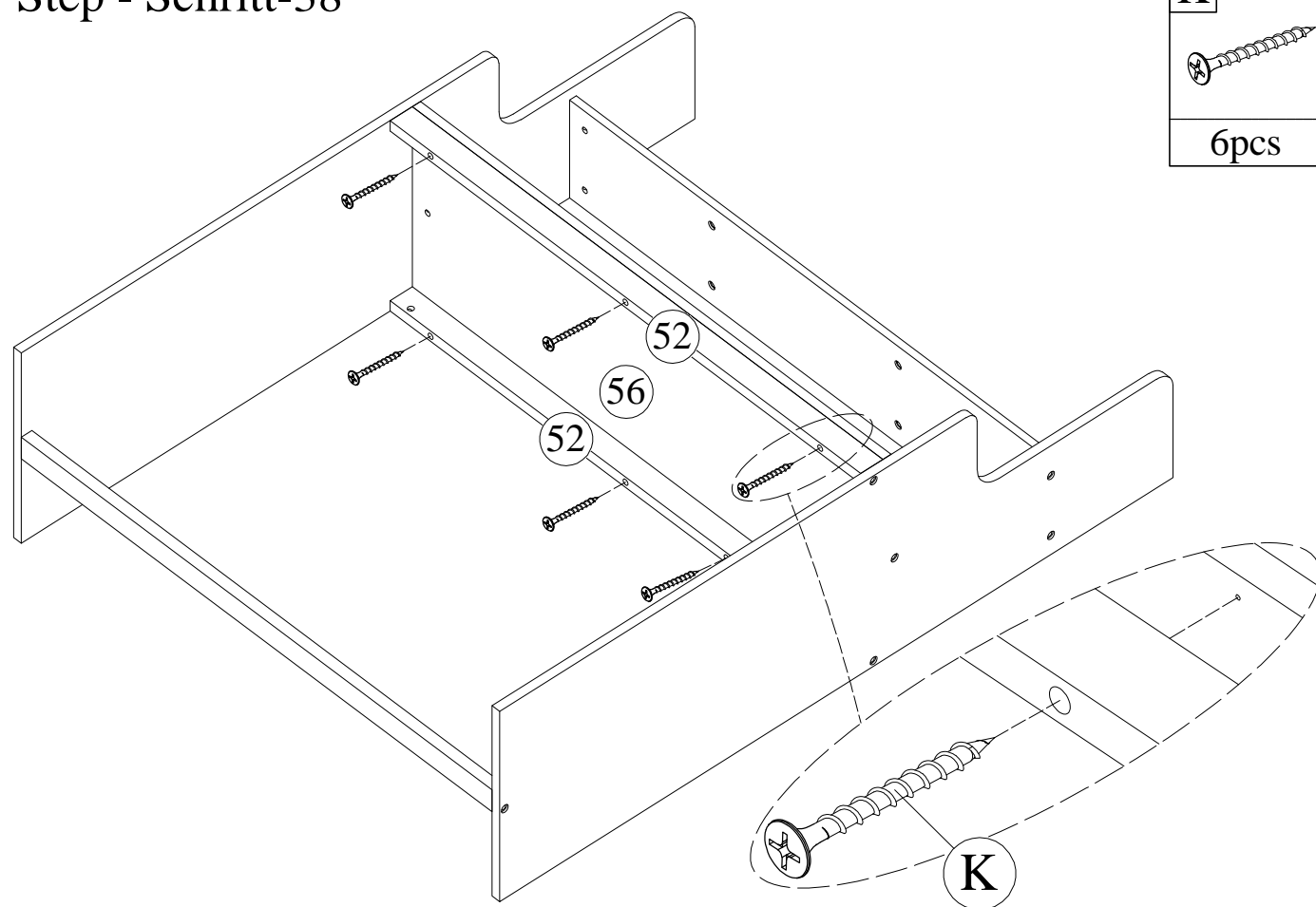

Step - Schritt-38

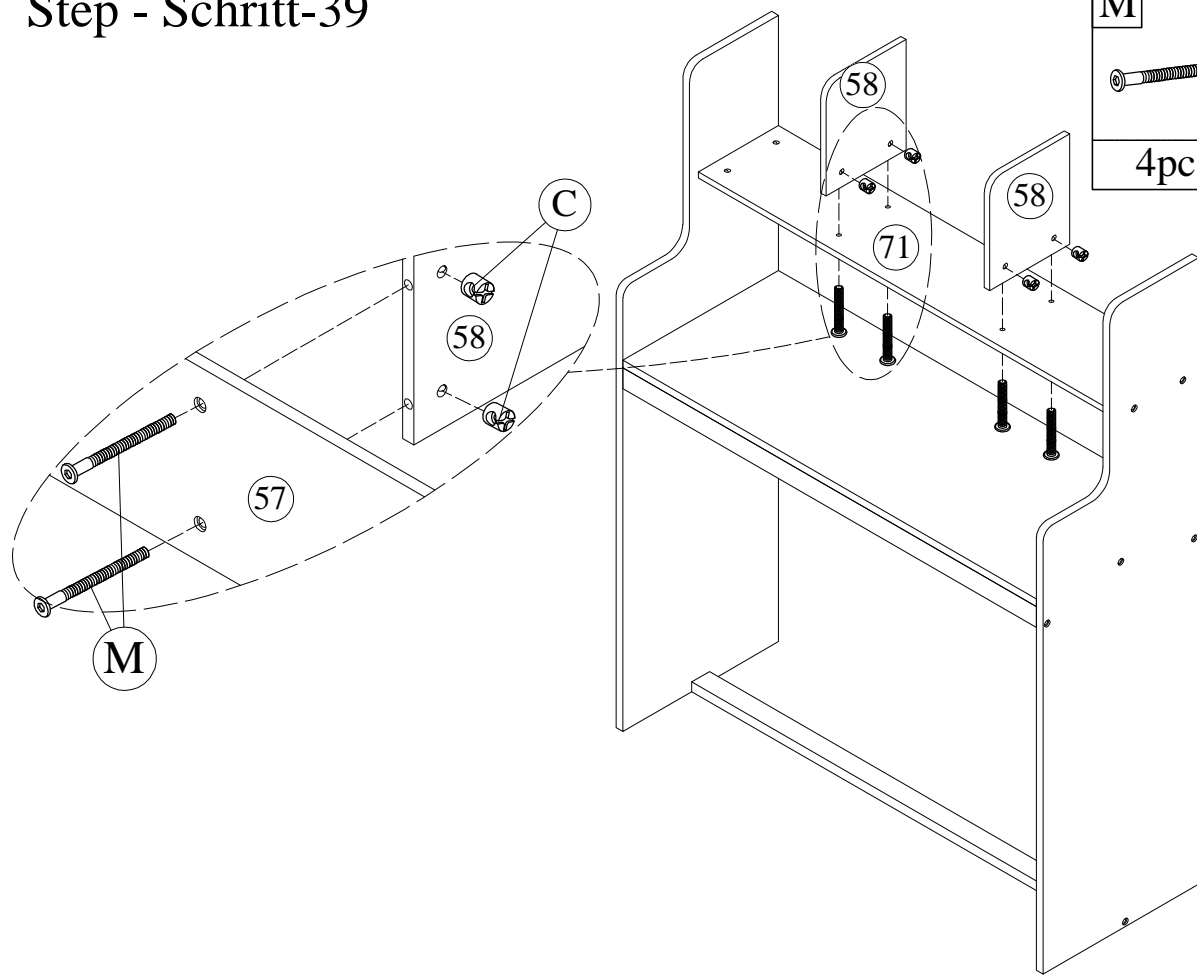

K 
6pcs

Step - Schritt-39



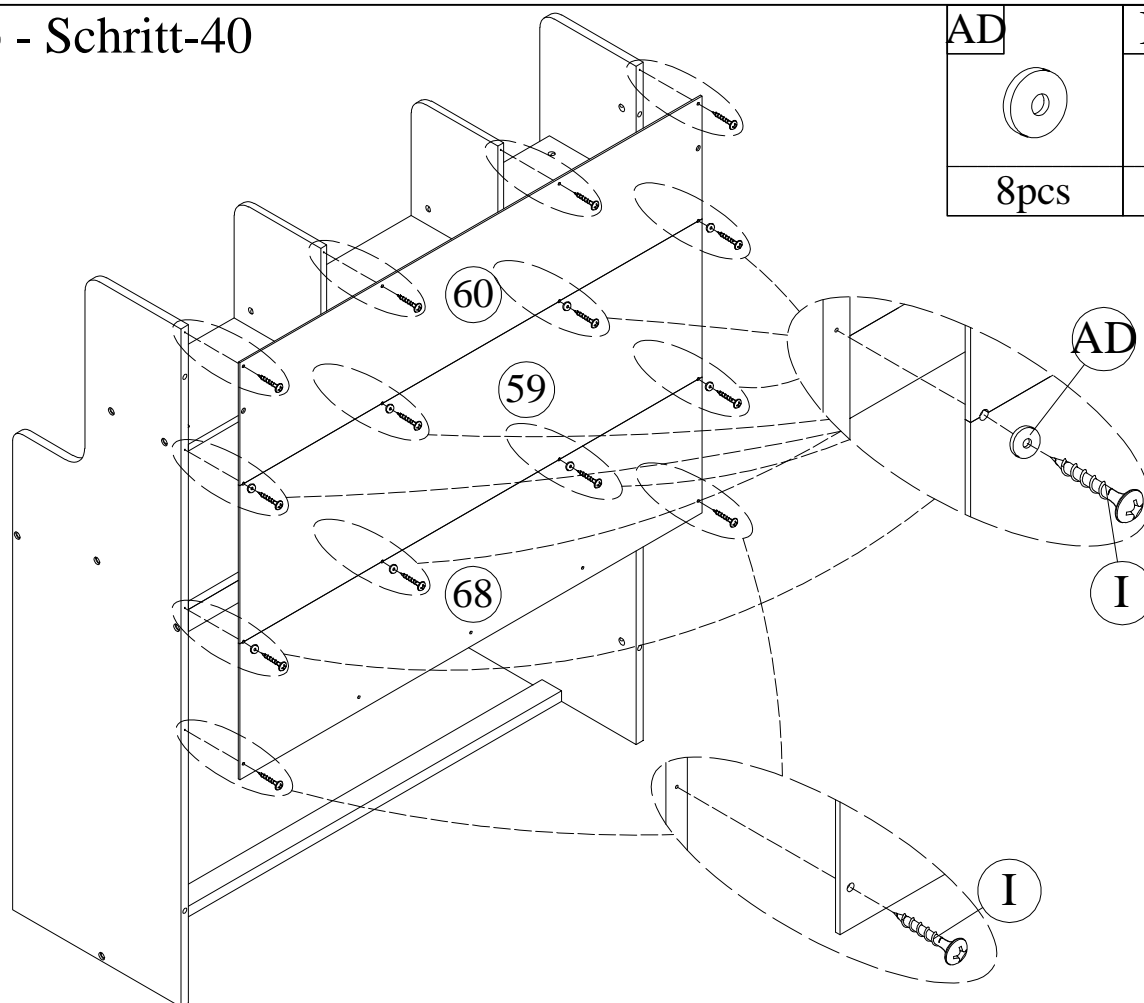

M 	C 
4pcs	4pcs

Step - Schritt-40

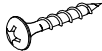

AD 	I 
8pcs	14pcs

Step - Schritt-41

C 	F 
4pcs	4pcs

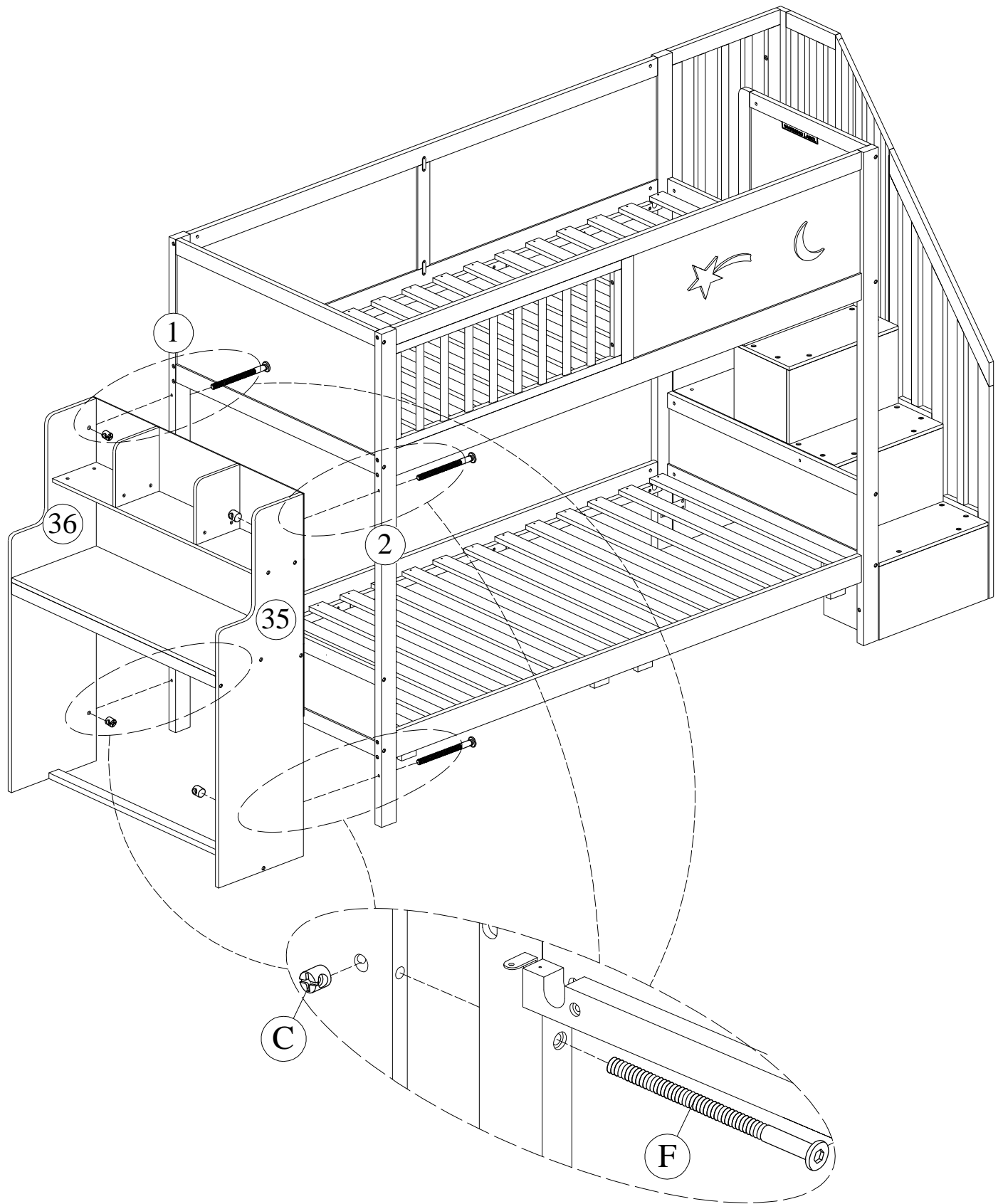

Step - Schritt-42

I

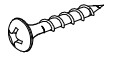

3pcs

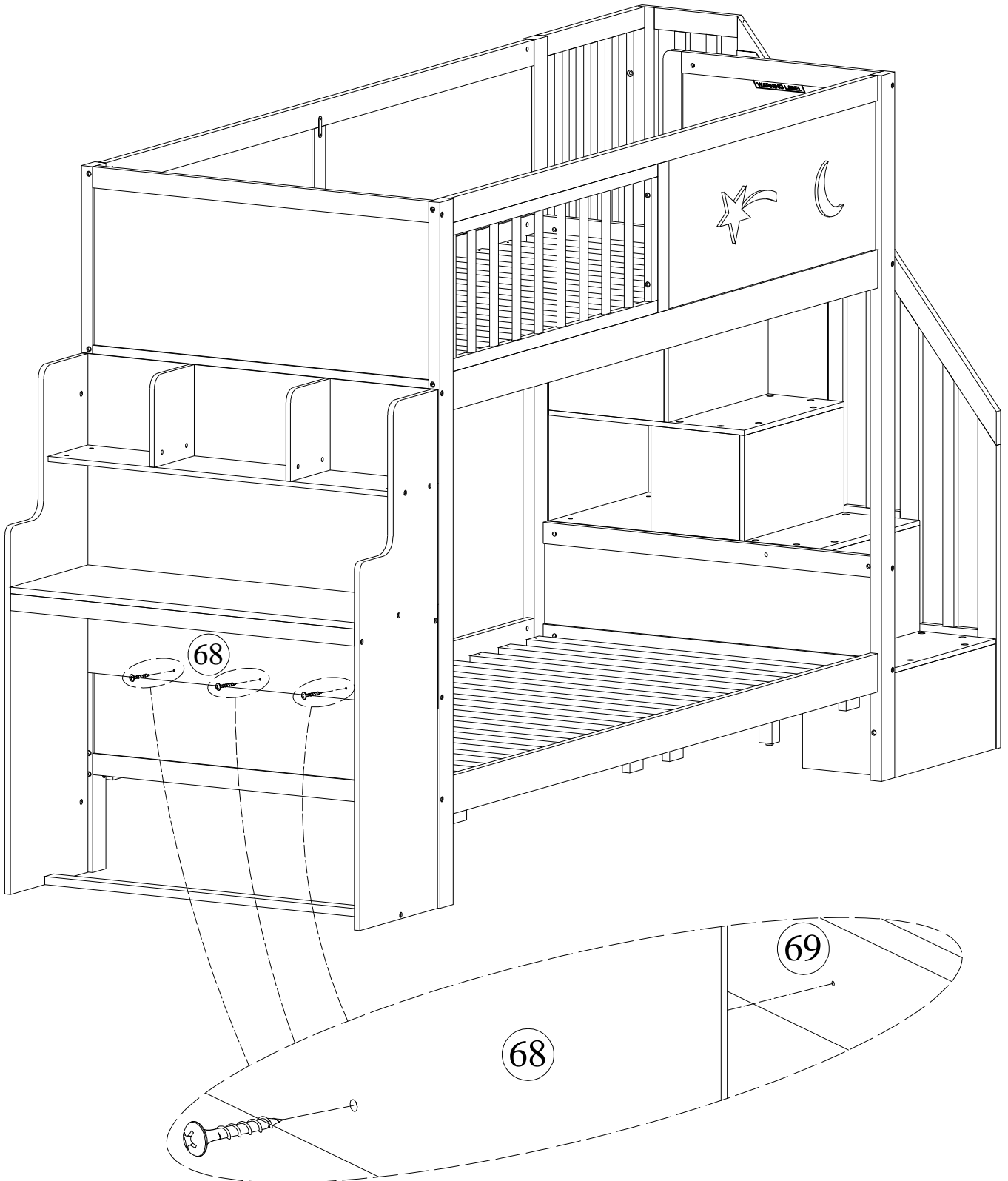

Step - Schritt-43

AA



8pcs

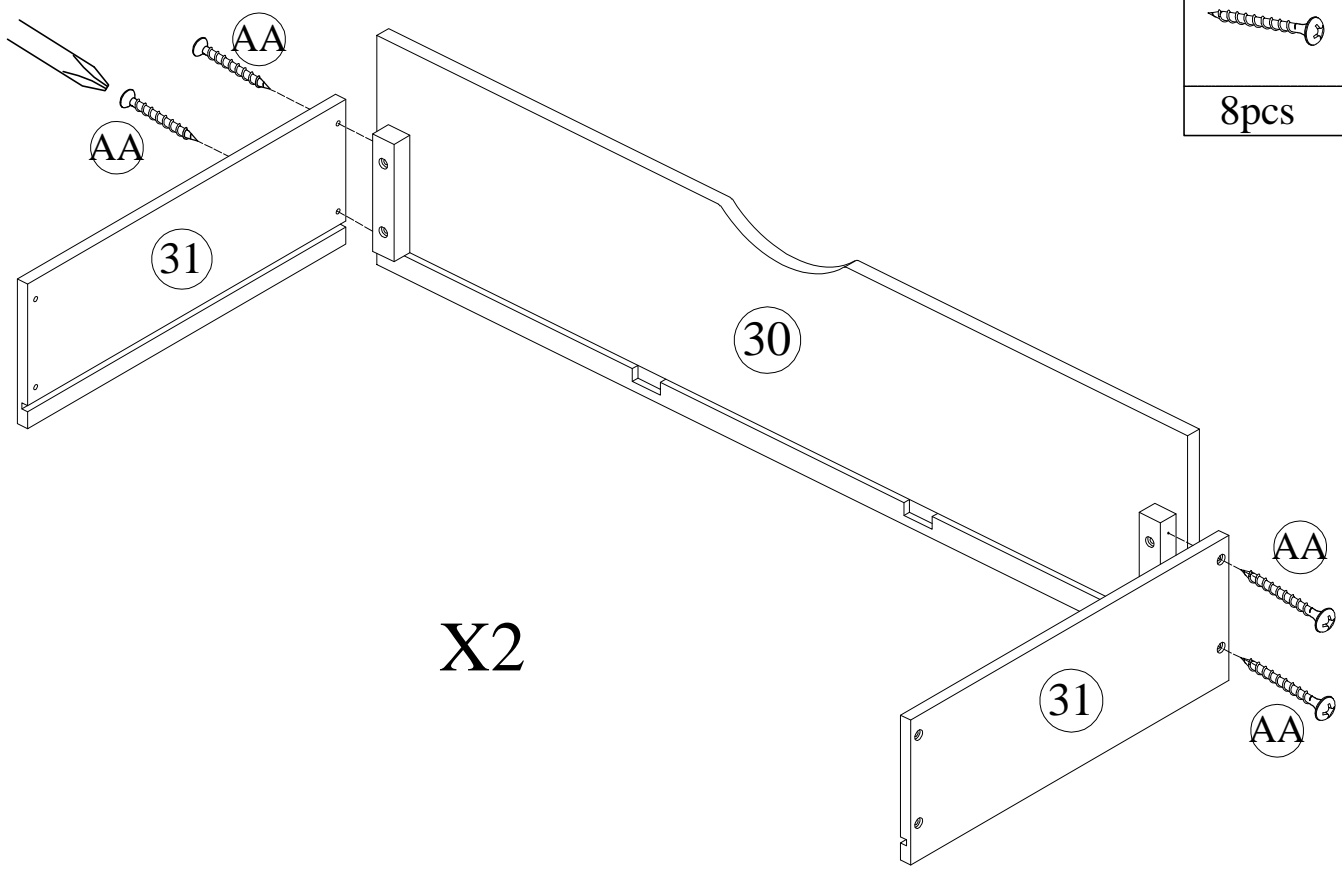

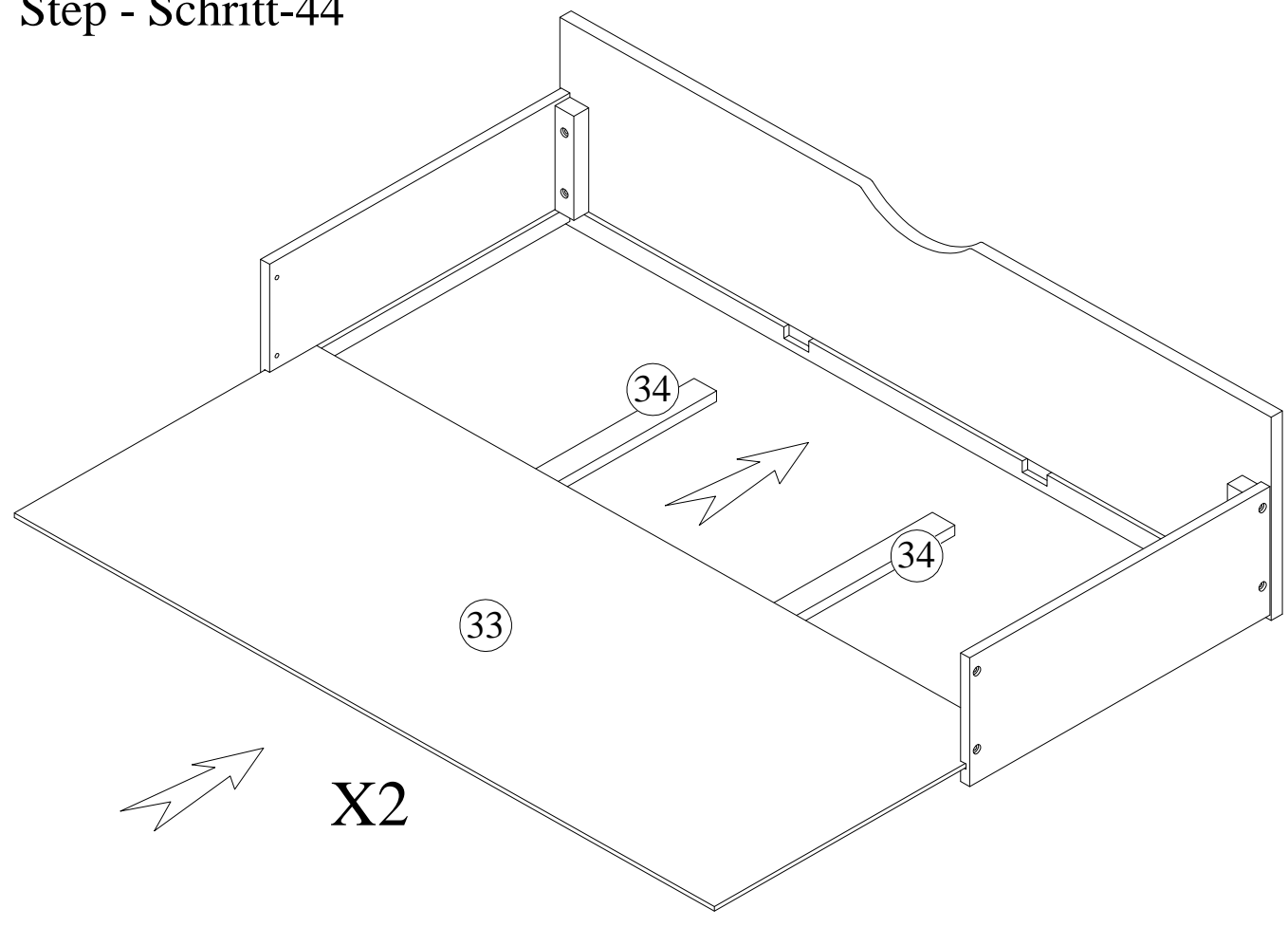

Step - Schritt-44



Step - Schritt-45

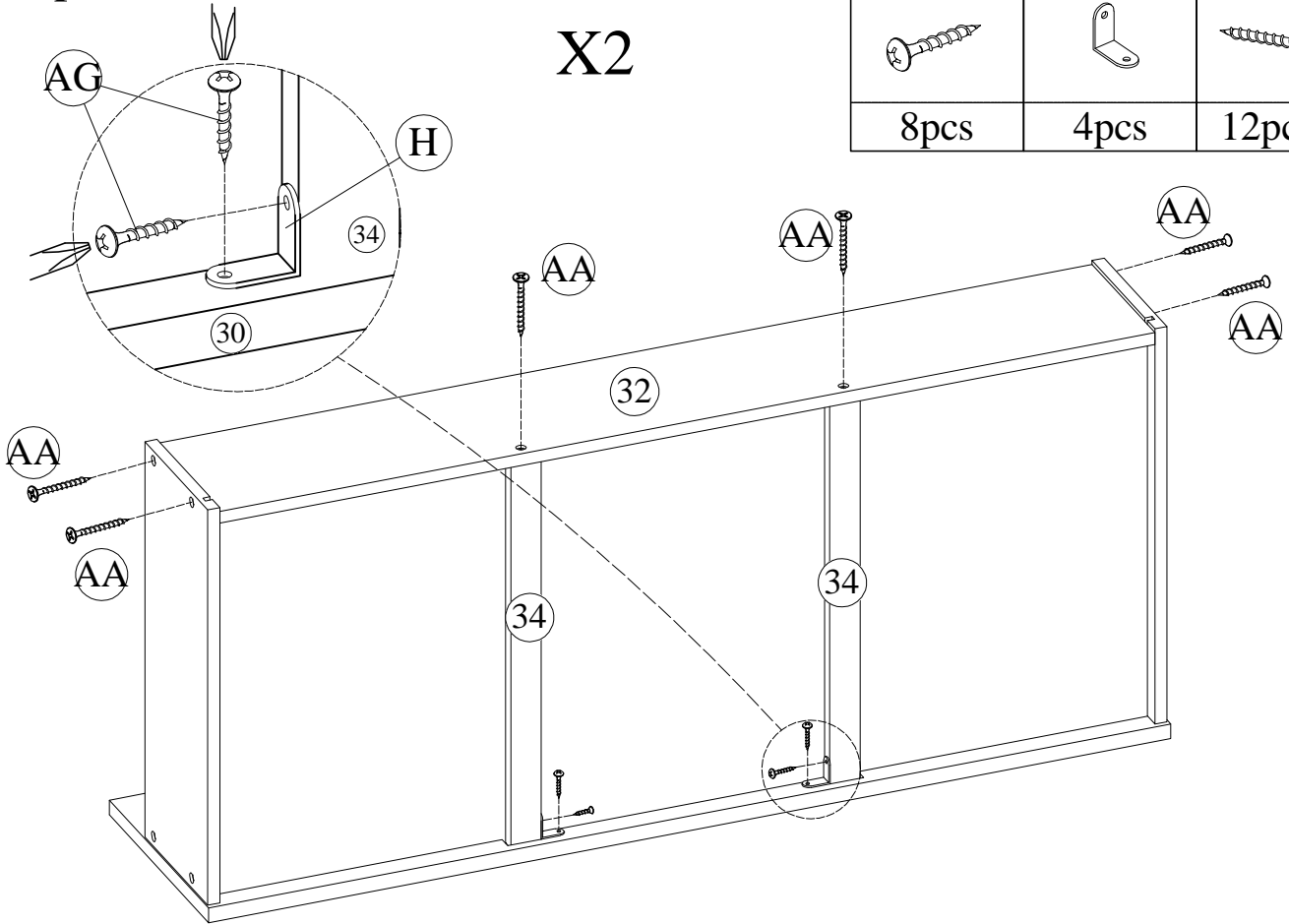

X2

AG	H	AA
		
8pcs	4pcs	12pcs



Step - Schritt-46

X2

I	Y
	
32pcs	8pcs

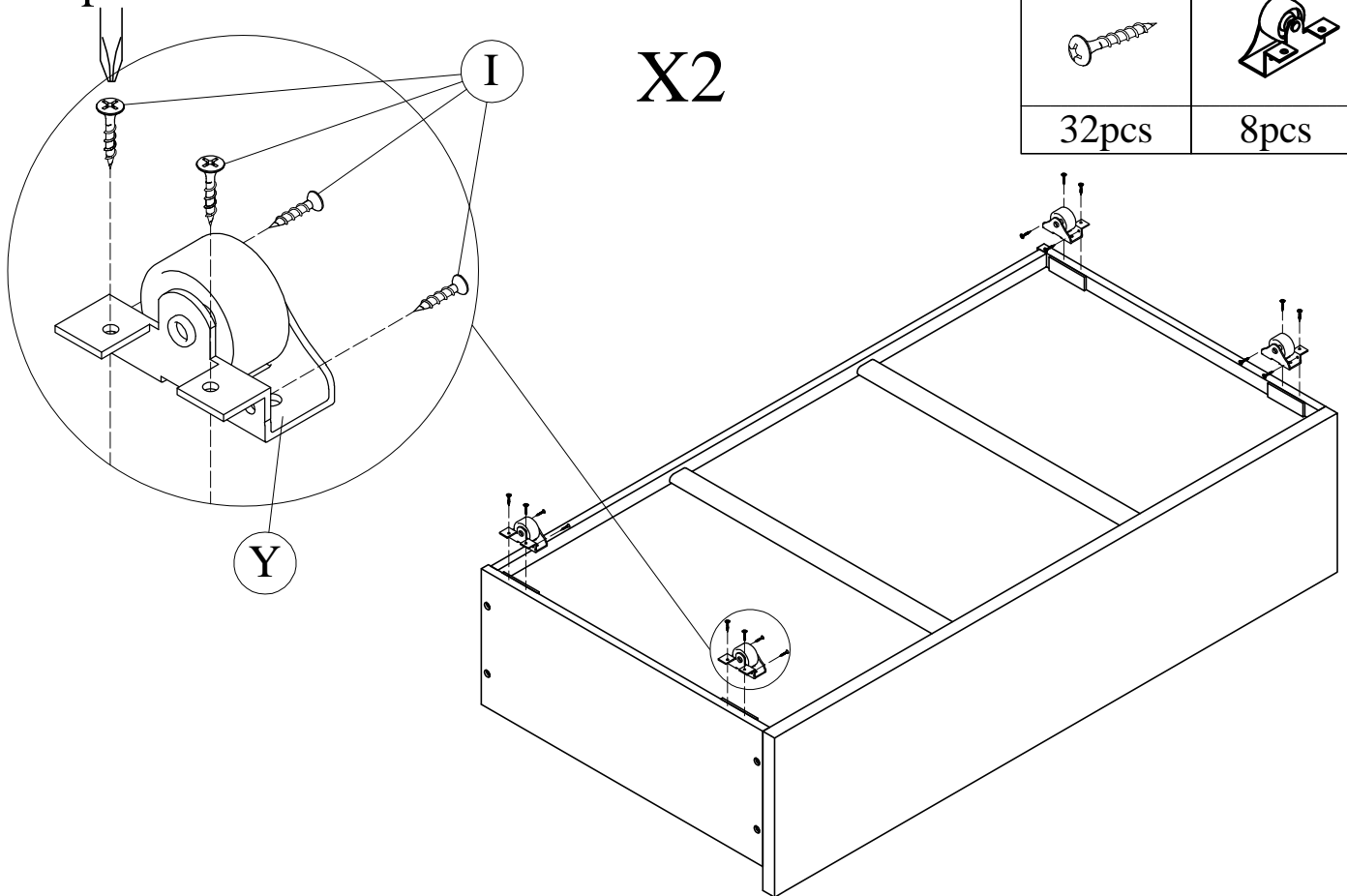

Step - Schritt-47

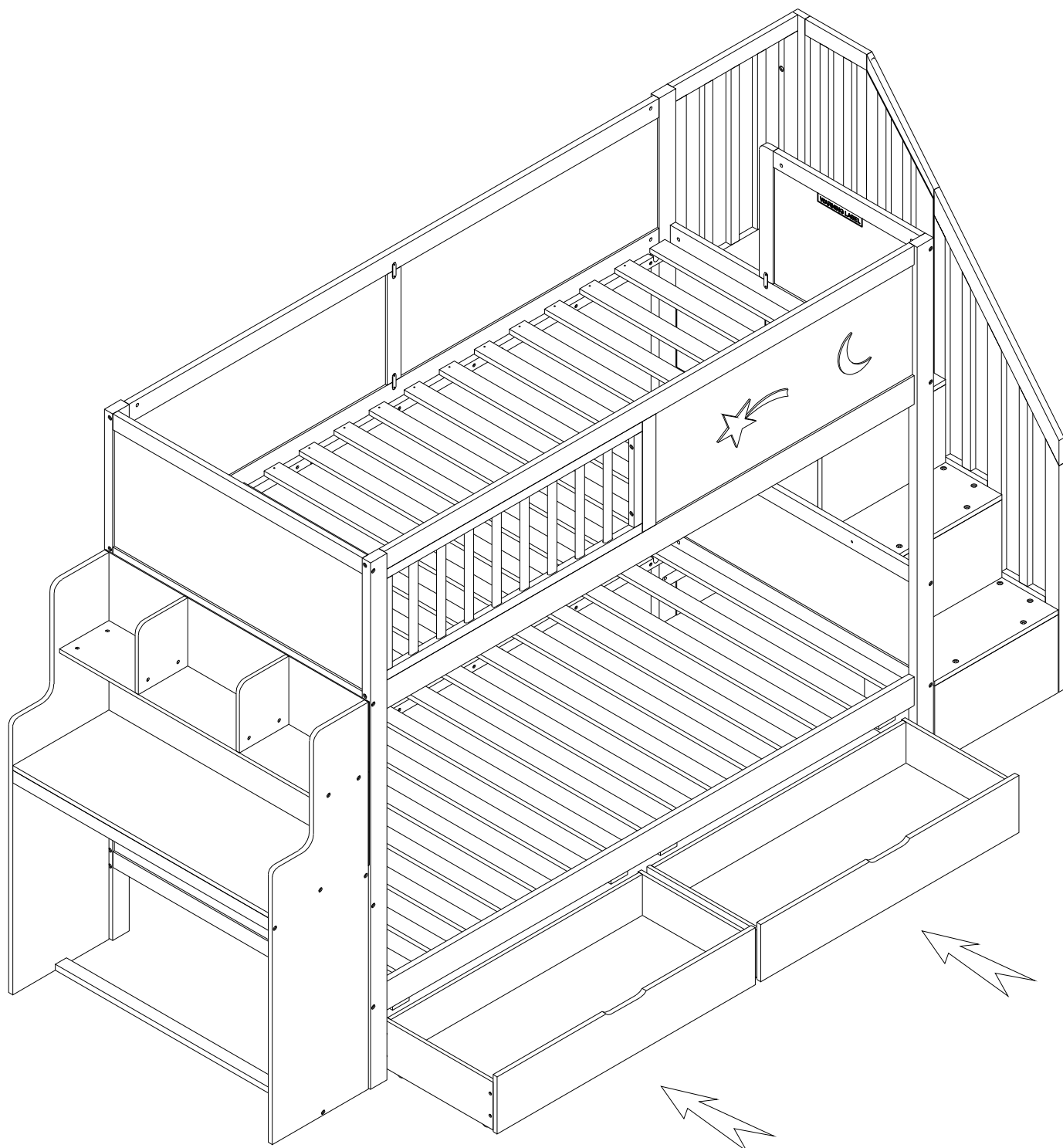

Step - Schritt-48

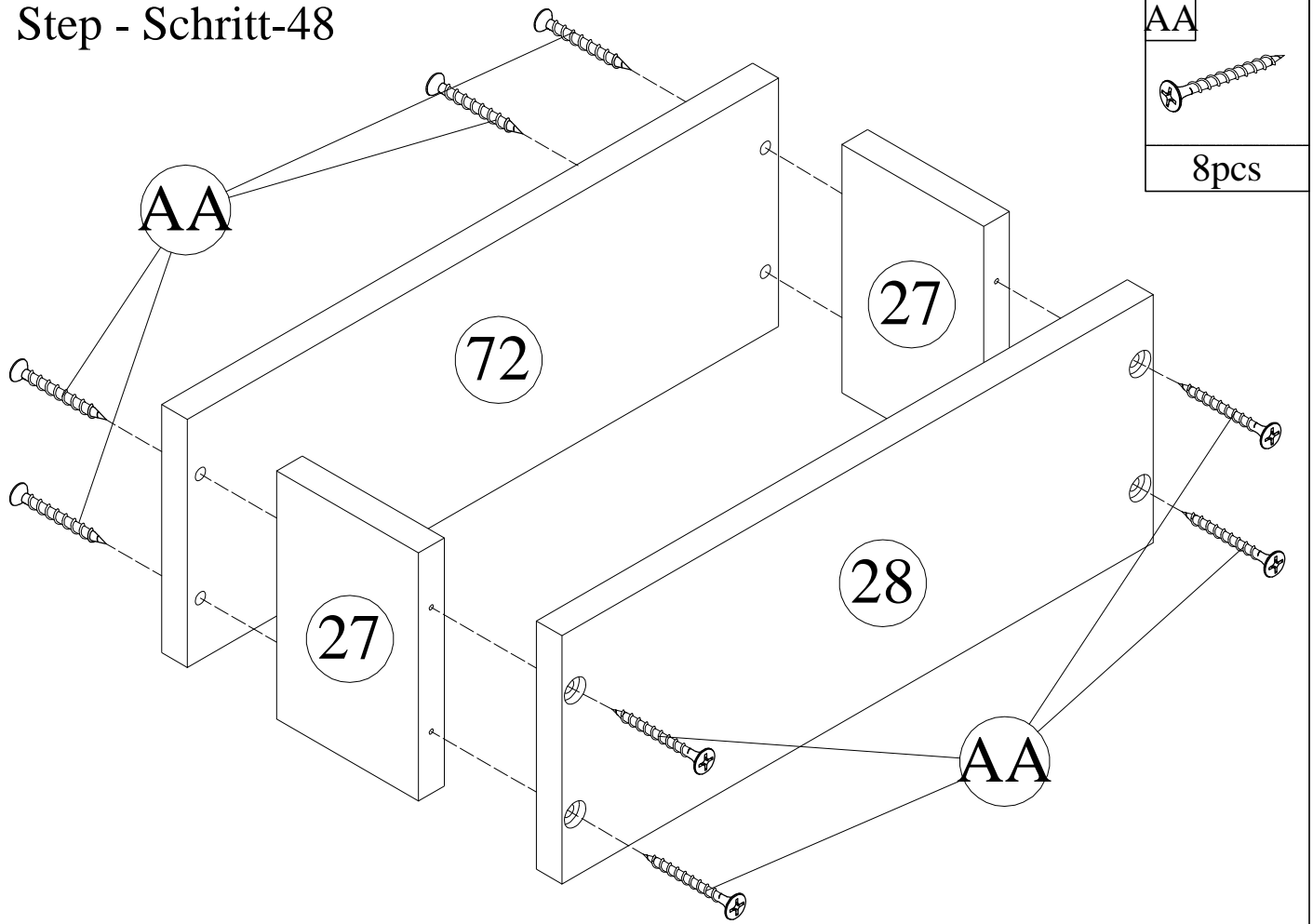

Step - Schritt-49

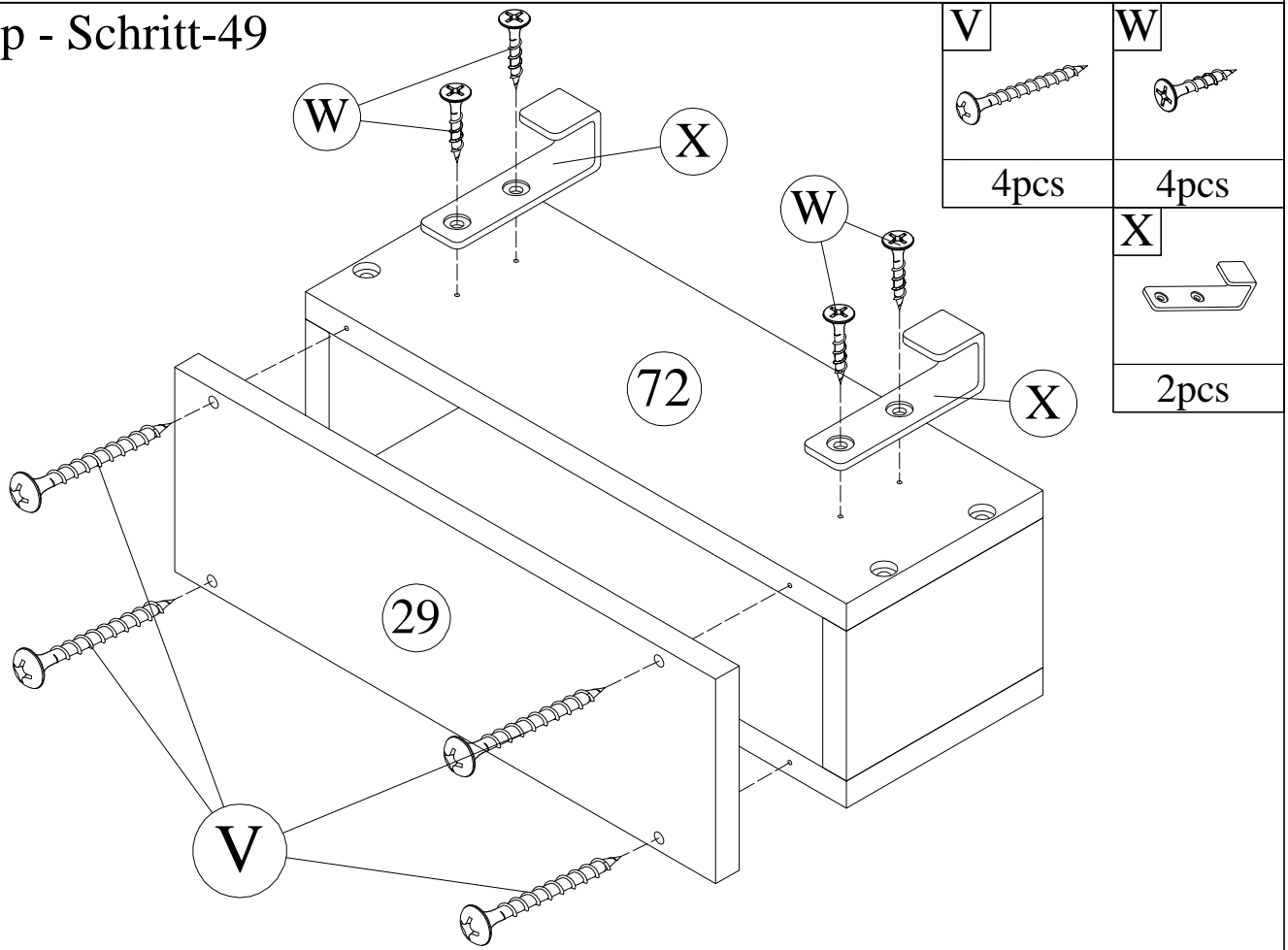

FINISH:
FINITION:

