

GER-MAT7602-N

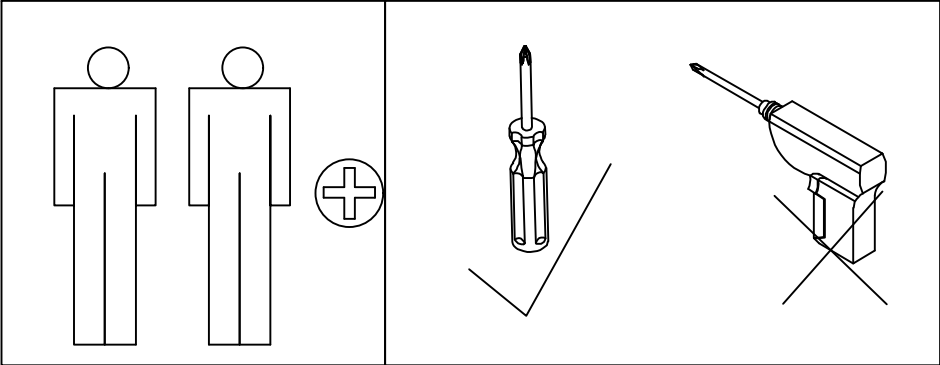
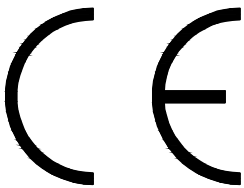
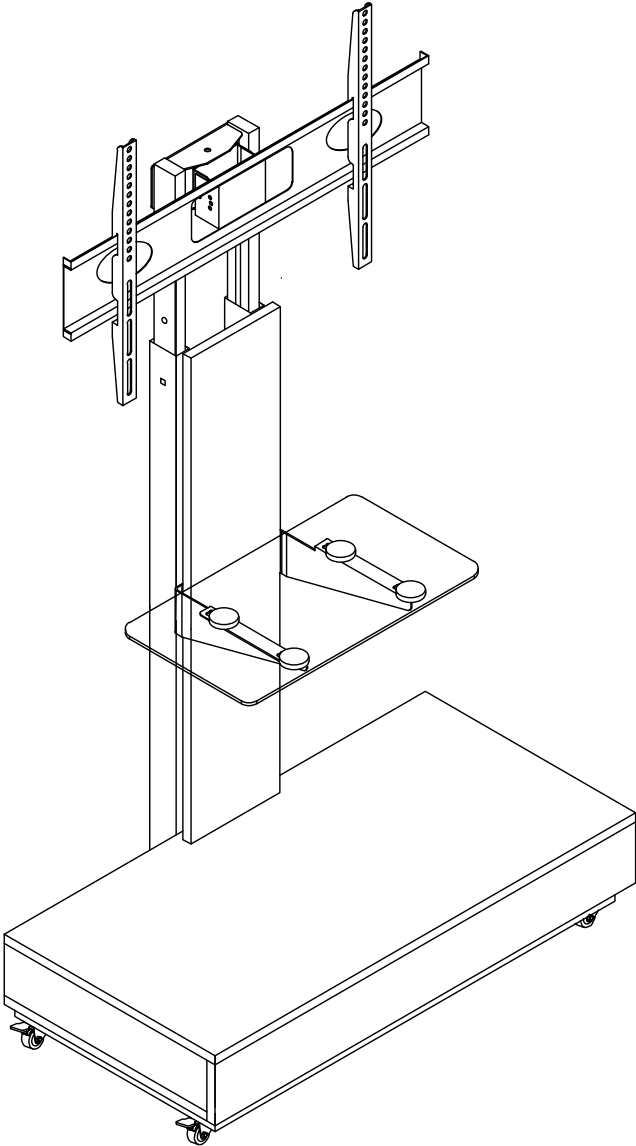

EN_Important Notes

1. Please inspect all components carefully before assembly.
2. During assembly, place the product on a soft, smooth surface (e.g., a carpet) to prevent scratching the parts.
3. Follow the assembly instructions in the correct sequence.
4. Do not fully tighten any screws until the product is completely assembled.
5. Returns are only accepted in the original packaging.
(*Assembled products are not eligible for return).

FR_Remarques importantes

1. Veuillez inspecter soigneusement tous les composants avant l'assemblage.
2. Lors de l'assemblage, placez le produit sur une surface lisse et molle (comme un tapis) pour éviter de rayer les pièces.
3. Suivez les instructions d'assemblage dans l'ordre indiqué.
4. Ne serrez aucune vis complètement avant que le produit ne soit entièrement assemblé.
5. Les retours ne sont acceptés que dans l'emballage d'origine.
(*Les produits assemblés ne peuvent pas être retournés).

ES_Notas importantes

1. Inspeccione todos los componentes minuciosamente antes del montaje.
2. Durante el montaje, coloque el producto sobre una superficie lisa y blanda (por ejemplo, una alfombra) para evitar que se rayen las piezas.
3. Siga las instrucciones de montaje en el orden correcto.
4. No apriete por completo ningún tornillo hasta que el producto esté completamente montado.
5. Las devoluciones solo se aceptarán en el embalaje original.
(*No se admiten devoluciones de productos ya montados).

DE_Wichtige Hinweise

1. Bitte überprüfen Sie vor der Montage alle Komponenten sorgfältig..
2. Stellen Sie das Produkt während der Montage auf eine glatte, weiche Oberfläche (z. B. einen Teppich), um Kratzer an den Teilen zu vermeiden.
3. Befolgen Sie die Montageanleitung in der vorgegebenen Reihenfolge.
4. Ziehen Sie die Schrauben erst vollständig fest, wenn das Produkt vollständig montiert ist.
5. Rücksendungen sind nur in der Originalverpackung möglich.
(*Montierte Produkte können nicht zurückgegeben werden).

IT_Note importanti

1. Prima dell'assemblaggio, ispezionate attentamente tutti i componenti.
2. Durante l'assemblaggio, posizionate il prodotto su una superficie liscia e morbida (ad esempio, un tappeto) per evitare di graffiare le parti.
3. Seguire le istruzioni di assemblaggio nell'ordine corretto.
4. Non serrare completamente le viti prima che il prodotto sia completamente assemblato.
5. Le resi sono accettati solo nella confezione originale.
(*I prodotti assemblati non possono essere restituiti).

USING CAM LOCK AND QUICKFIT

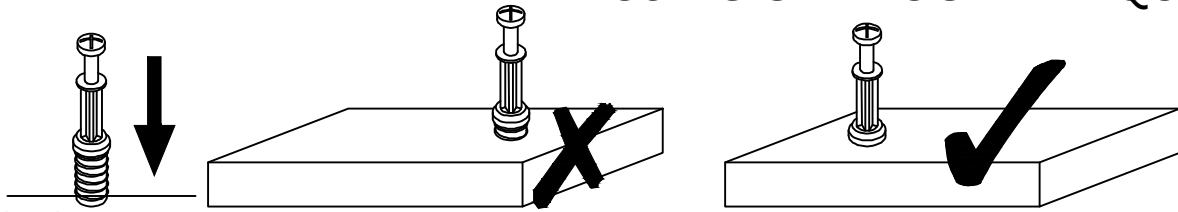

EN_QUICKFIT: Tighten quickfit until shoulder is flush with panel. Do not overtighten or undertighten.

FR_RACCORD RAPIDE: Faites serrer le raccord rapide jusqu'à ce que l'épaulement soit parfaitement encastré dans le panneau. Il ne faut ni trop serrer ni insuffisamment serrer.

ES_QUICKFIT: Apriete quickfit hasta que el hombro se descargue con el panel. NO lo sobreapriete ni lo apriete poco.

DE_QUICKFIT: Ziehen Sie den Quickfit fest, bis die Schulter mit der Platte bündig ist. Bitte nicht zu fest oder zu schwach anziehen.

IT_MONTAGGIO RAPIDO: Stringere il montaggio rapido fino a quando la spalla è a filo con il pannello, non stringere troppo o troppo poco.

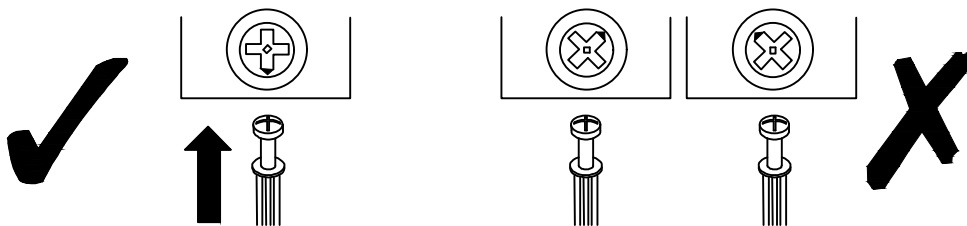

EN CAM LOCK: When fitting cam lock, ensure starting position is correct before you insert connecting quickfit.

FR SERRURE BATTEUSE: Avant d'insérer la serrure batteuse, veillez à la bonne orientation avant d'insérer le raccord rapide.

ES CIERRE DE LACAMARA: Cuando instale el cierre de la cámara, asegúrese de que la posición de inicio es correcta antes de que inserte el quickfit conector.

DE CAM-LOCK: Achten Sie bei der Montage des Cam-Locks auf die richtige Ausgangsposition, bevor Sie den Quickfit einsetzen.

IT BLOCCAGGIO A CAMMA: Quando si monta il bloccaggio a camma, assicurarsi che la posizione iniziale sia corretta prima di inserire il montaggio rapido di collegamento.

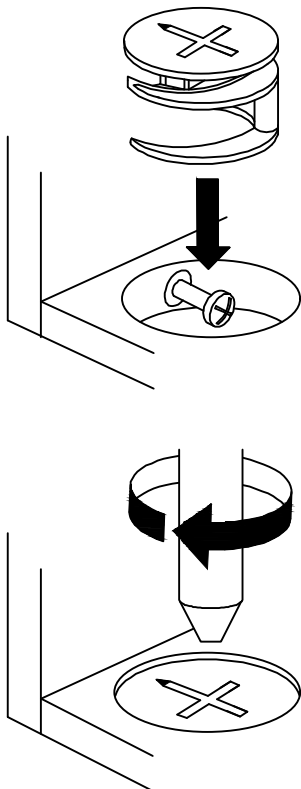

EN_Quickfit head should be in the centre of the cam lock when the two panels are joined.

Cam lock should be inserted before quickfit.

FR_Lorsque les deux panneaux sont assemblés, la tête du raccord rapide doit reposer au centre de la serrure batteuse. Il faut insérer la serrure batteuse avant le raccord rapide.

ES_El cabezal del quickfit debe estar en el centro del cierre de la cámara cuando se unan los dos paneles.

Se debe insertar el cierre de la cámara antes que el quickfit.

DE_Der Quickfit-Kopf sollte sich in der Mitte des Cam-Locks befinden, wenn die beiden Platten zusammengefügt sind.

Der Cam-Lock sollte vor dem Quickfit eingesetzt werden.

IT_La testa del montaggio rapido deve trovarsi al centro del bloccaggio a camma quando i due pannelli sono uniti

Il Bloccaggio a Camma deve essere inserito prima del montaggio rapido.

EN_Turn cam lock clockwise to tighten.





FR_Faites tourner la serrure batteuse dans le sens des aiguilles d'une montre pour la resserrer.



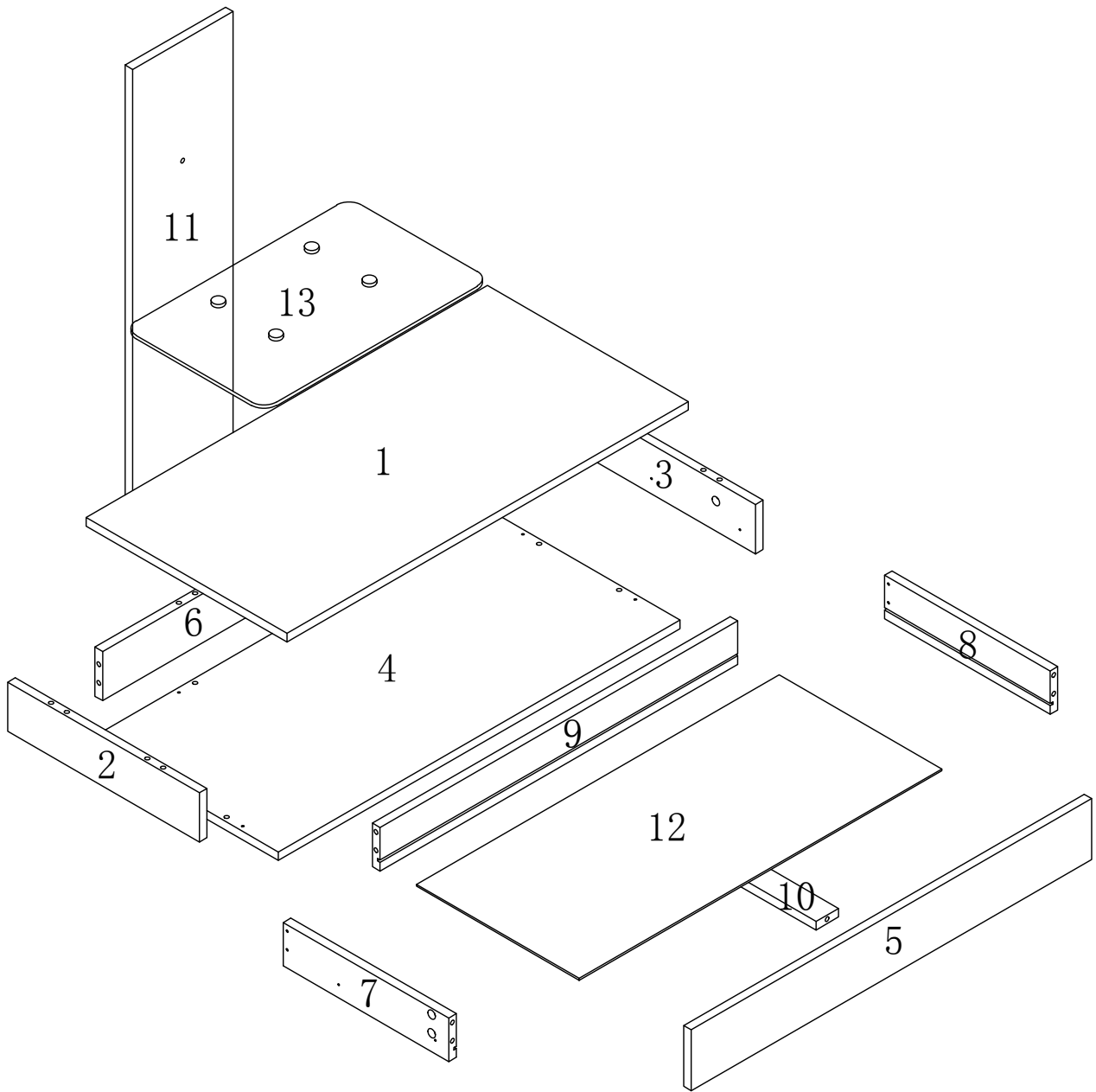

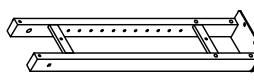

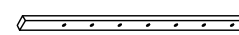
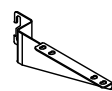
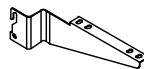
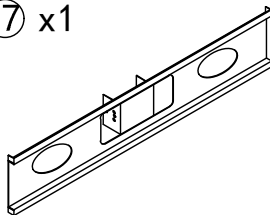
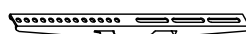

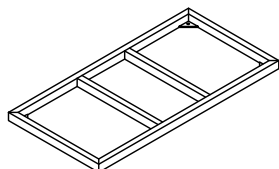
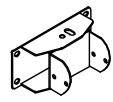

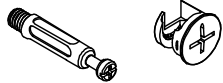
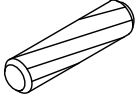
ES_Gire el cierre de la cámara en sentido horario para apretarlo

DE_Drehen Sie den Cam-Lock im Uhrzeigersinn, um ihn festzuziehen.

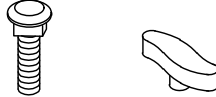
IT_Ruotare il bloccaggio a camma in senso orario per stringere.

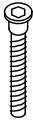
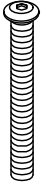

<p>⑭ x1</p> 	<p>⑮ x1 (SET)</p> <p>(Right)</p>  <p>(Left)</p> 	<p>⑯ x1 (SET)</p>  <p>(Left)</p>  <p>(Right)</p>	<p>⑰ x1</p> 
<p>⑱ x2</p> 	<p>⑲ x4</p> 	<p>⑳ x1</p> 	<p>㉑ x1</p> 

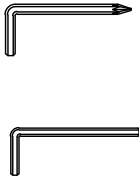
<p>A x15</p>  <p>A1 A2 ϕ 6*38mm ϕ 15*11mm</p>	<p>B x12</p>  <p>ϕ 8*40mm</p>	<p>C x8</p>  <p>ST3.5*14mm</p>	<p>D x11</p>  <p>ST4*35mm</p>
<p>E x4</p>  <p>M6*12mm E1 E2</p>	<p>F x2</p>  <p>M6*35mm F1 F2</p>	<p>G x2</p>  <p>M8*30mm G1 G2</p>	<p>H x2 (SET) 350mm</p> 
<p>I x2</p>  <p>M7*70mm</p>	<p>J x2</p>  <p>M6*100mm</p>	<p>K x4</p>  <p>M6*40mm K1 K2</p>	<p>L x3</p> 
<p>M x12</p>  <p>M6*8mm</p>	<p>N x2</p> 		

1

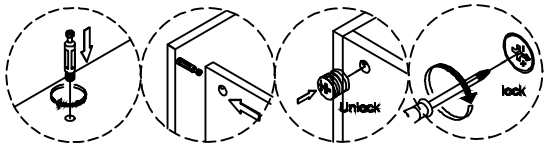
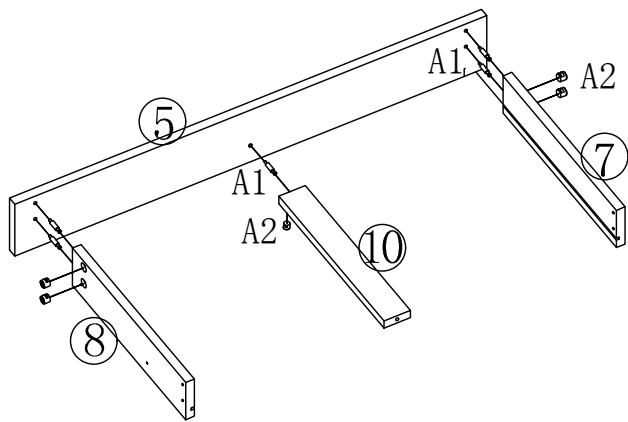

2

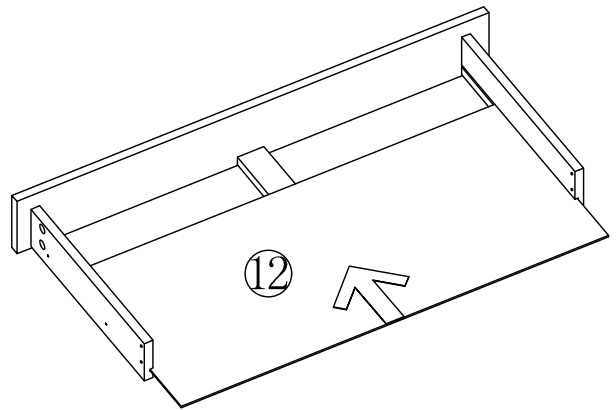

3

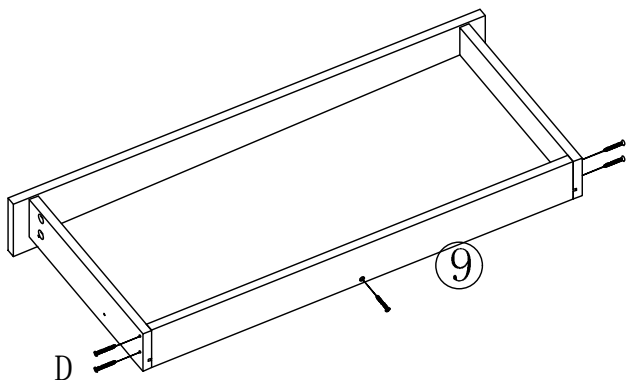

4

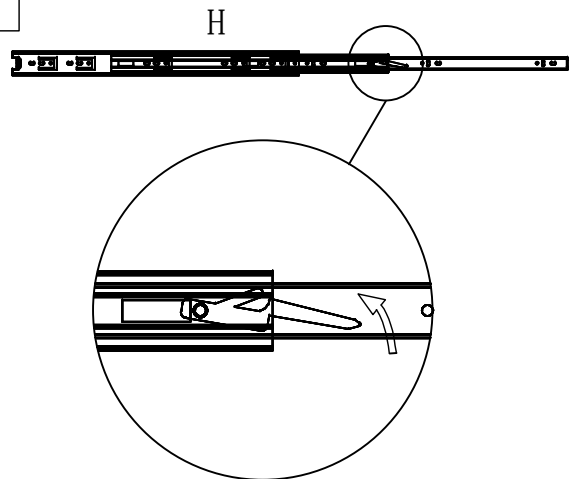

EN_To remove the inner fixing rail, please press the dismounting rod.
 FR_Pour retirer le rail de fixation interne, veuillez appuyer sur la tige de démontage.
 ES_Para retirar el riel de fijación interior, presione la varilla de desmontaje.
 DE_Um die innere Befestigungsschiene zu entfernen, drücken Sie bitte auf die Demontagestange.
 IT_Per rimuovere la guida di fissaggio interna, premere l'asta di smontaggio.

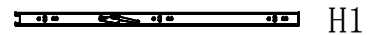

H1



H2

5

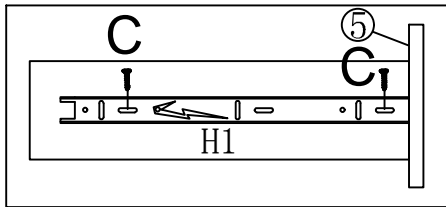
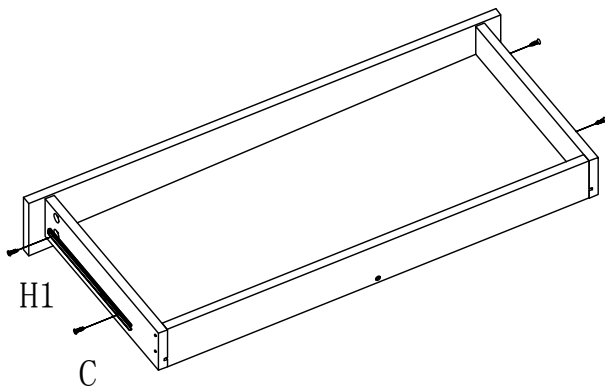

6

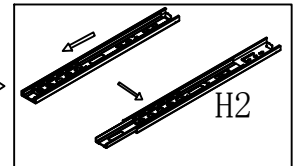
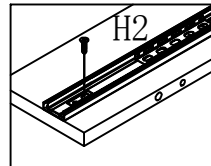
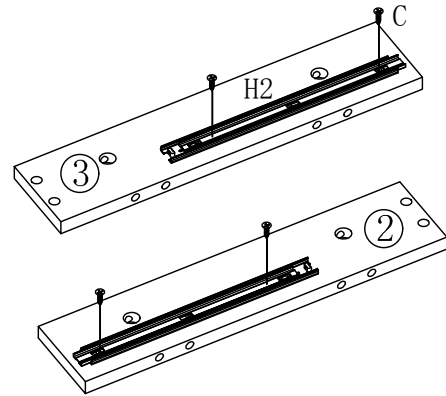

EN_Position the smaller end of H2 flush with the metal panel. Then, screw a C-type screw into the first hole.

FR_L'extrémité la plus petite de H2affleure la tôle, et une vis C est vissée dans le premier trou.

ES_El extremo más pequeño de H2queda al ras con la chapa metálica, y se atornilla un tornillo C en el primer orificio.

DE_Das schmalere Ende von H2 schließt bündig mit dem Blech ab, und eine C-Schraube wird in das erste Loch geschraubt.

IT_L'estremità più piccola dell'H2è a filo con la lamiera e una vite C è avvitata nel primo foro.

EN_Slide out the track of H2

FR_Faites glisser la glissière de H2.

ES_Deslice hacia fuera la guía de H2.

DE_Schieben Sie die Schiene von H2 heraus.

IT_Far scorrere fuori il binario di H2

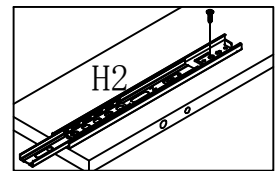

EN_Align the screw with the second hole and tighten it.

FR_Alignez la vis sur le deuxième trou et serrez-la.

ES_Alinee el tornillo con el segundo orificio y apriételo.

DE_Richten Sie die Schraube am zweiten Loch aus und ziehen Sie sie fest.

IT_Allineare la vite al secondo foro e serrarla.

7

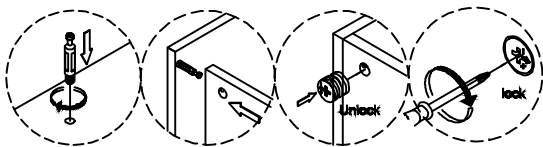
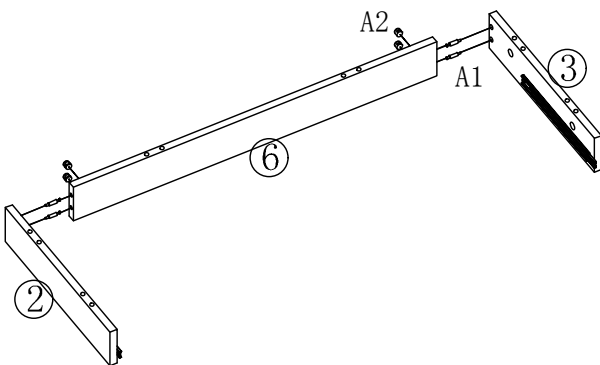

8

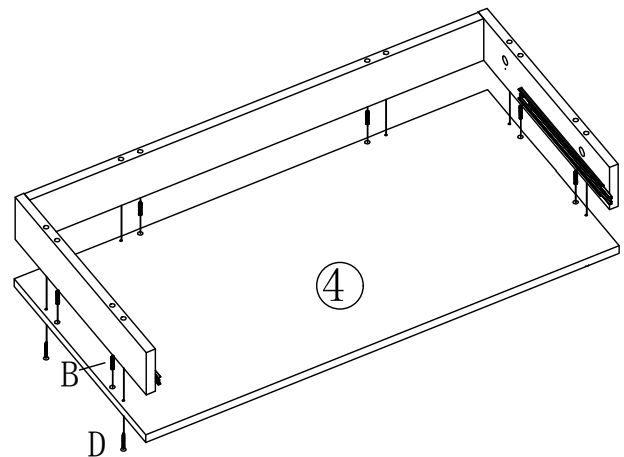

9

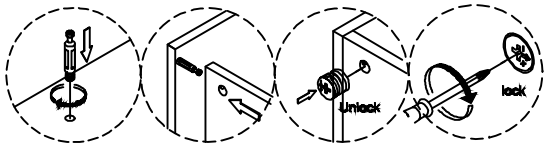
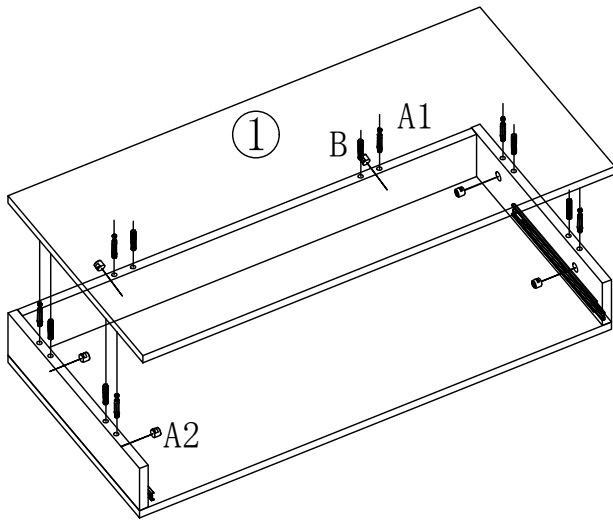

10

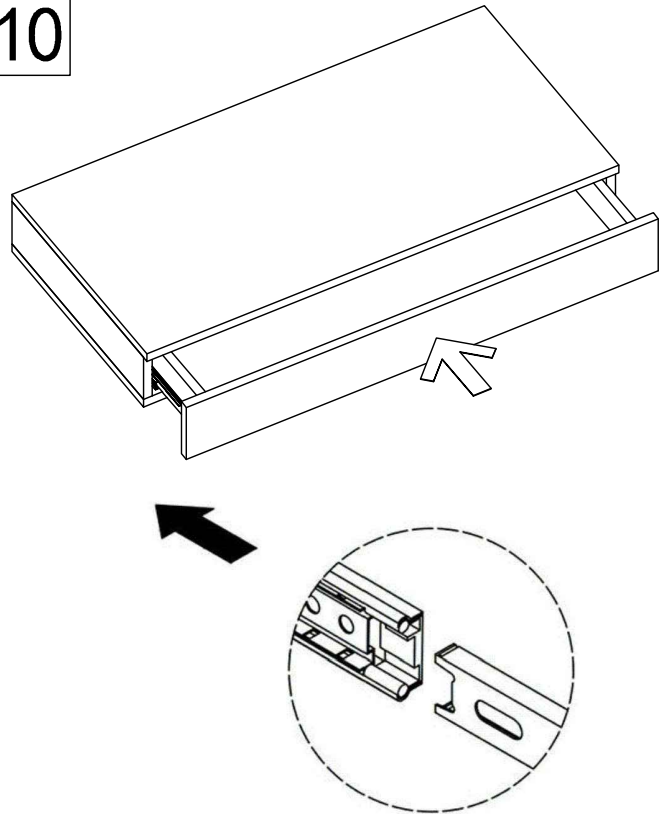

EN_Align the outer track with the center of the inner track and push in.
 FR_Alignez la piste extérieure avec le centre de la piste intérieure et enfoncez-la.
 ES_Alinee el riel exterior con el centro del riel interior e insértelo.
 DE_Richten Sie die äußere Schiene an der Mitte der inneren Schiene aus und drücken Sie sie hinein.
 IT_Allinea la guida esterna al centro della guida interna e spingila per inserirla.

11

EN_Apply the brakes before installing the wheels.
 FR_Serrez les freins avant d'installer les roues.
 ES_Aplique los frenos antes de instalar las ruedas.
 DE_Betätigen Sie die Bremsen, bevor Sie die Räder montieren.
 IT_Azionare i freni prima di installare le ruote.

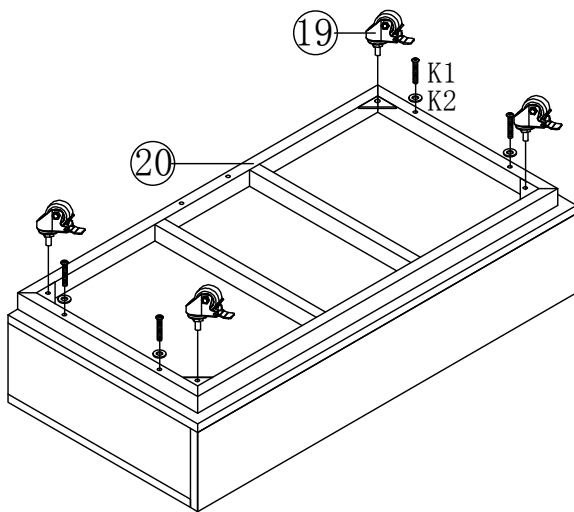
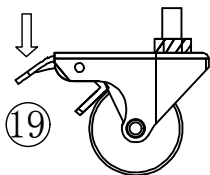

12

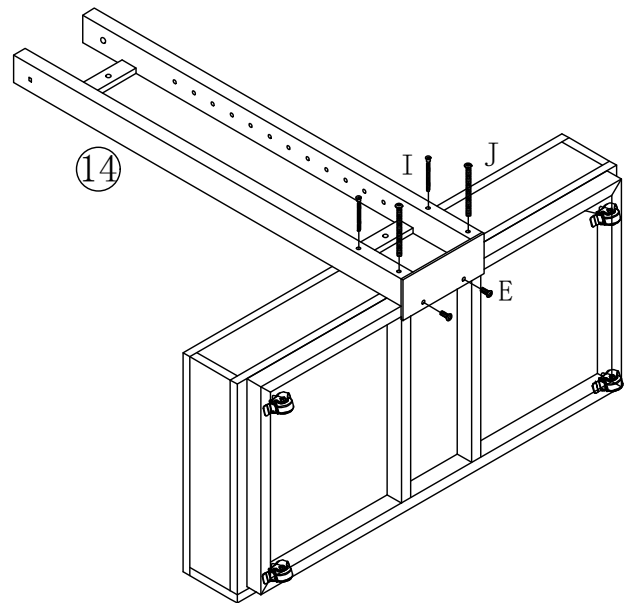

13

EN_Left
FR_Gauche
ES_Izquierda
DE_Links
IT_Sinistra

EN_Right
FR_Droite
ES_Correcto
DE_Richtig
IT_Giusto

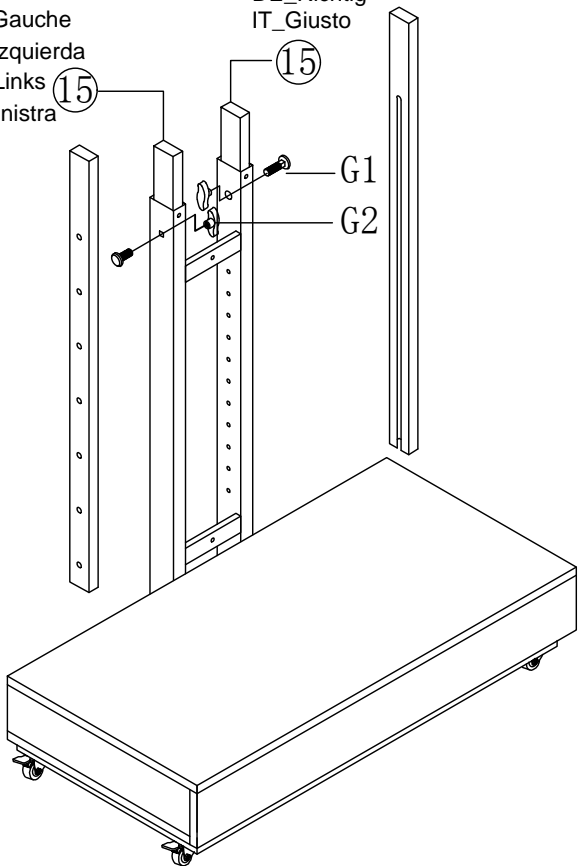

14

EN_Left
FR_Gauche
ES_Izquierda
DE_Links
IT_Sinistra

EN_Right
FR_Droite
ES_Correcto
DE_Richtig
IT_Giusto

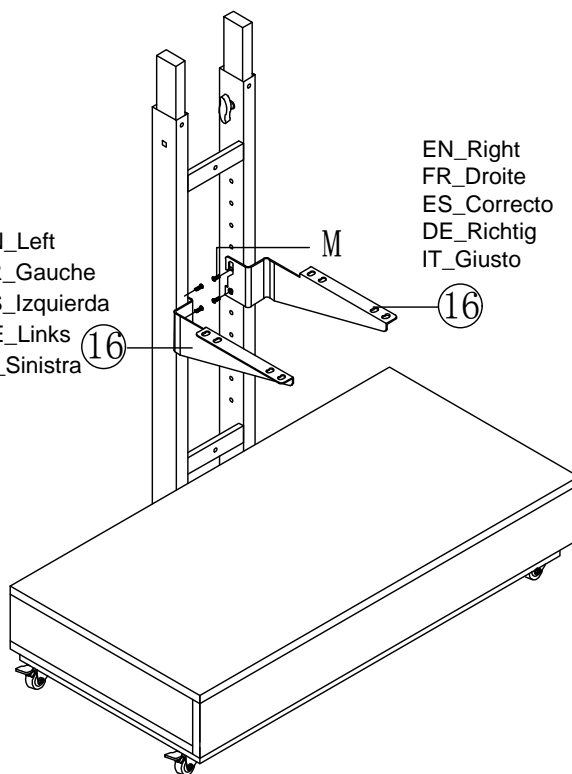

15

F1

F2

3

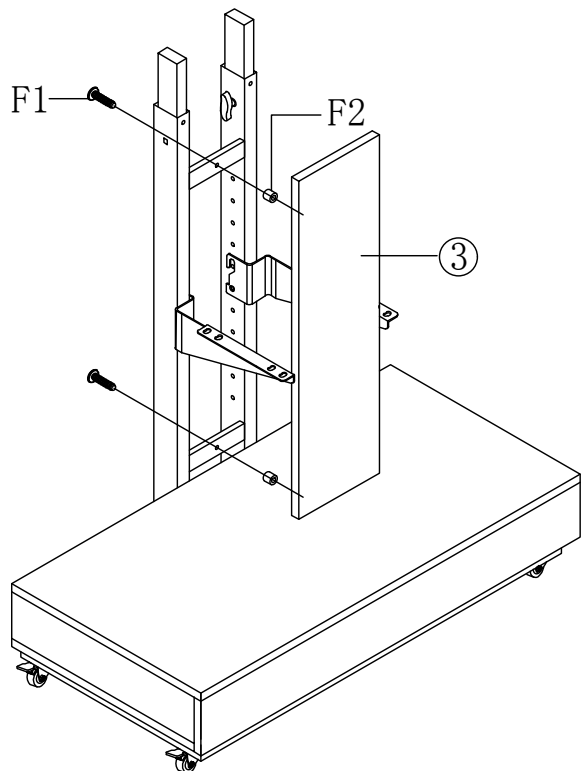

16

17

L

E

21

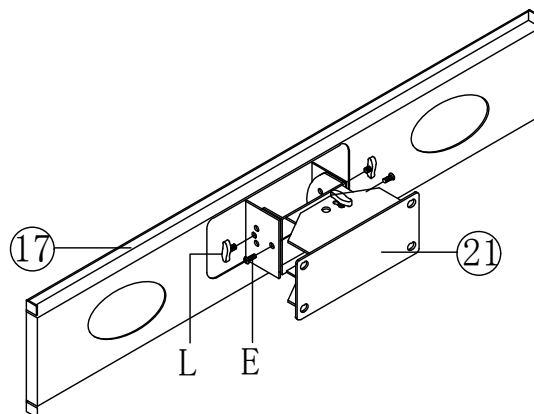

17

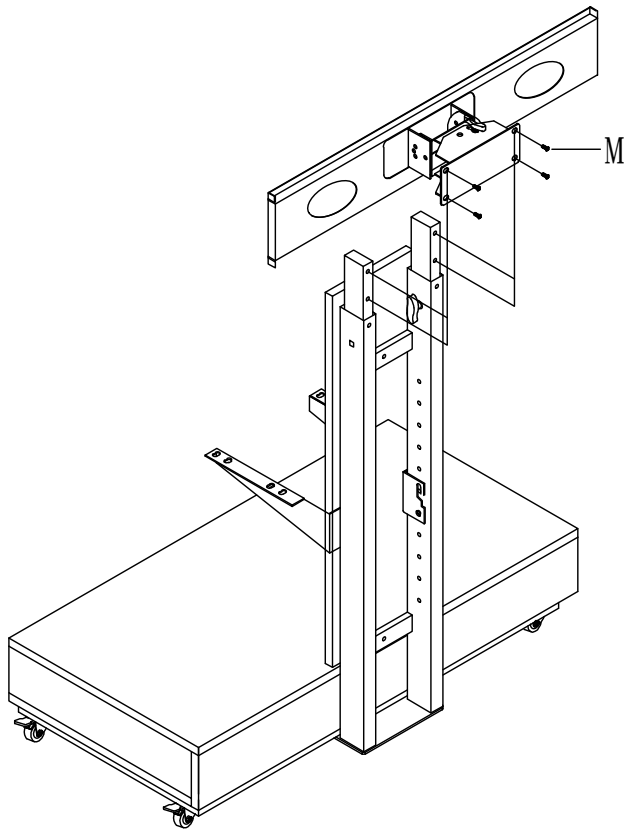

18

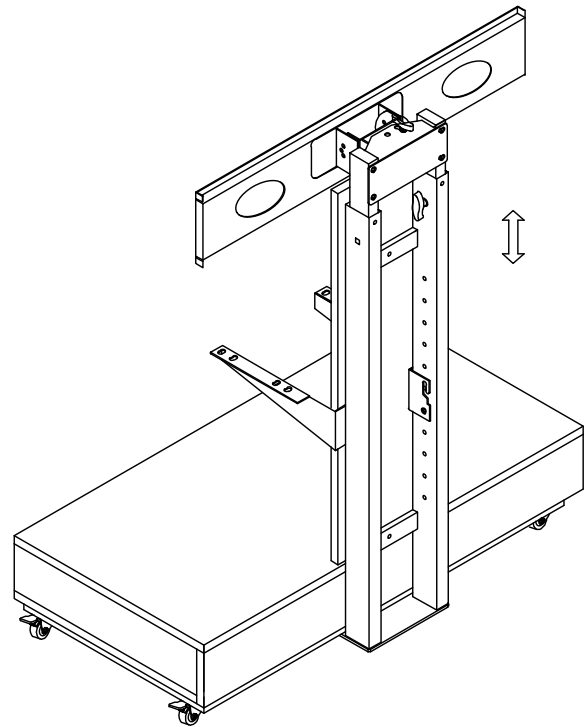

19

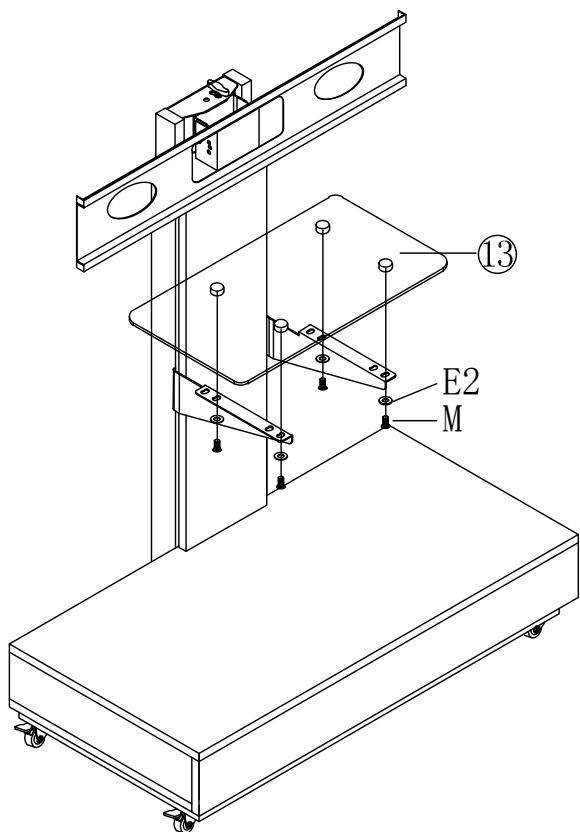

20

EN_Please be careful not to drop the TV.
 FR_Veuillez à ne pas faire tomber le téléviseur.
 ES_Tenga cuidado de no dejar caer el televisor.
 DE_Achten Sie darauf, den Fernseher nicht fallen zu lassen.
 IT_Prestare attenzione a non far cadere il televisore.

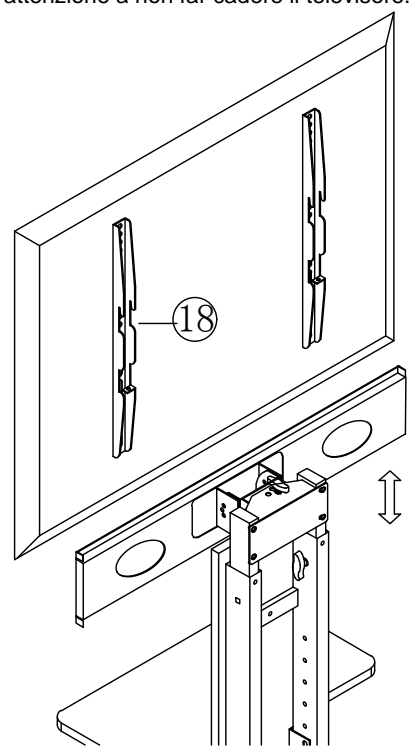

21

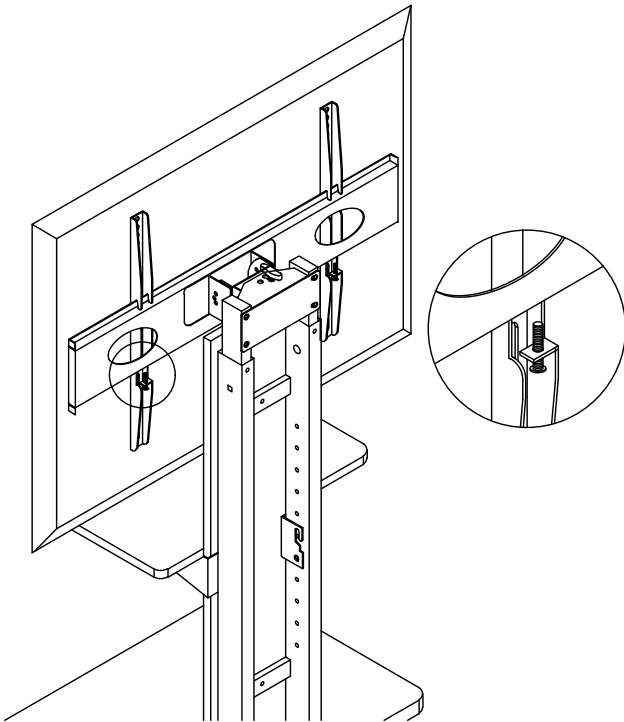

EN_[Left and right angle adjustment]

Loosen the adjustment bolts shown in the figure to adjust the left and right angles. After adjusting the angle, tighten the bolts.

FR_[Réglage de l'angle gauche et droit]

Desserrez les boulons de réglage indiqués sur la figure pour régler les angles gauche et droit. Après avoir réglé l'angle, resserrez les boulons.

ES_[Ajuste del ángulo izquierdo y derecho]

Afloje los pernos de ajuste que se muestran en la figura para ajustar los ángulos izquierdo y derecho. Después de ajustar el ángulo, apriete los pernos.

DE_[Einstellung des linken und rechten Winkels]

Lösen Sie die in der Abbildung gezeigten Einstellschrauben, um den linken und rechten Winkel einzustellen. Ziehen Sie die Schrauben nach der Winkeleinstellung wieder fest.

IT_[Regolazione dell'angolo sinistro e destro]

Allentare i bulloni di regolazione mostrati nella figura per regolare gli angoli sinistro e destro. Dopo aver regolato l'angolo, serrare i bulloni.

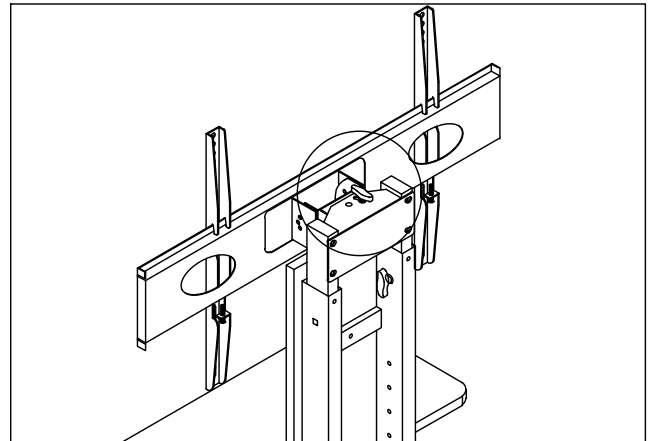

EN_Angle adjustment
FR_Réglage de l'angle
ES_Ajuste del ángulo
DE_Winkelverstellung
IT_Regolazione dell'angolo

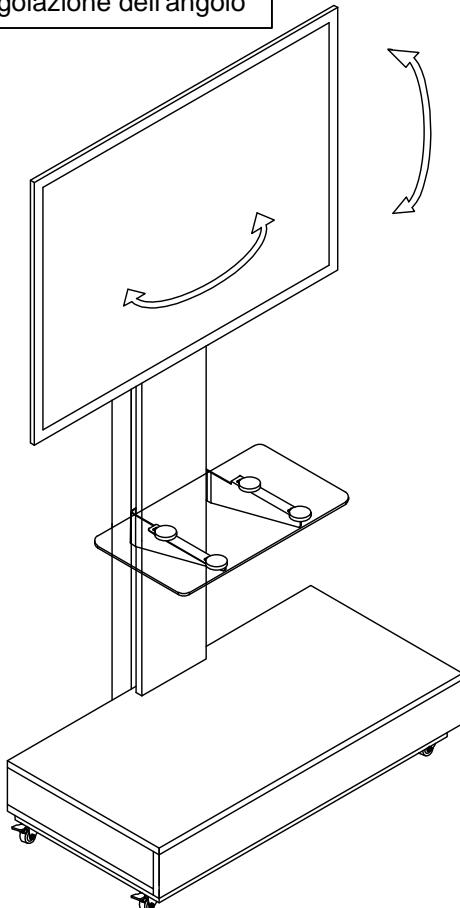

EN_[Vertical angle adjustment]

Three levels of angle adjustment are possible. Loosen the adjustment bolts (left and right) shown in the figure, insert them into the three holes at any angle you like, and tighten them.

FR_[Réglage de l'angle vertical]

Trois niveaux de réglage de l'angle sont possibles. Desserrez les boulons de réglage (gauche et droit) indiqués sur la figure, insérez-les dans les trois trous à l'angle souhaité, puis resserrez-les.

ES_[Ajuste del ángulo vertical]

Se pueden realizar tres niveles de ajuste del ángulo. Afloje los pernos de ajuste (izquierdo y derecho) que se muestran en la figura, insértelos en los tres orificios en el ángulo que desee y apriéte los.

DE_[Vertikale Winkeleinstellung]

Es sind drei Stufen der Winkeleinstellung möglich. Lösen Sie die in der Abbildung gezeigten Einstellschrauben (links und rechts), stecken Sie sie in einem beliebigen Winkel in die drei Löcher und ziehen Sie sie fest.

IT_[Regolazione dell'angolo verticale]

Sono disponibili tre livelli di regolazione dell'angolo. Allentare i bulloni di regolazione (sinistro e destro) mostrati nella figura, inserirli nei tre fori con l'angolazione desiderata e serrarli.

