

SKU N635P327257

Importeur	Decobus Handel GmbH
Adresse	Innungsstraße 9,21244Buchholz,Deutschland
Email/URL	https://www.decobusgroup.de
Hersteller	ZHANGZHOU XINZUOBIAO INDUSTRY & TRADE CO.,LTD
Address	BeidouIndustrial Zone,ZhangzhouCity, Fujian Province,China
Emai//URL	2092167066@qq.com
Partienummer	N635P327257
Hergestellt in	China
EC REP	Decobus Handel GmbH Innungsstraße 9,21244Buchholz,Deutschland https://www.decobusgroup.de

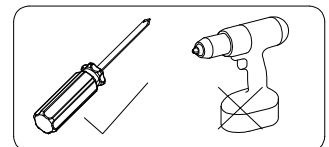
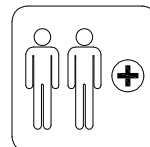
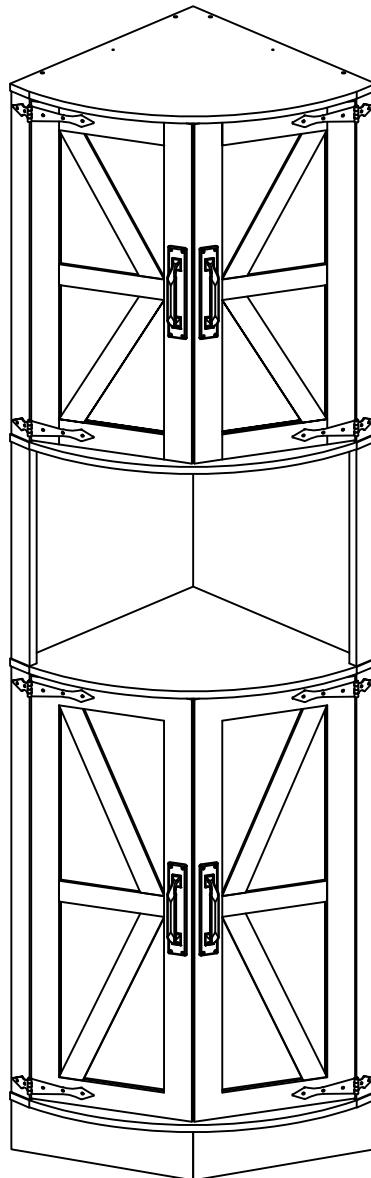

EN_IMPORTANT,RETAIN FOR FUTURE REFERENCE;READ CAREFULLY.

FR_IMPORTANT:A LIRE ATTENTIVEMENT ET ACONSERVER POUR CONSULTATION ULTERIEURE.

ES_IMPORTANTE,LEA Y GARDE PARA FUTURAS REFEREBCUAS.

DE_„,WICHTIG!SORGEALTIG LESEN UND FUR SPATER NACHSCHLAGEN AUFBEWAHREN."

IT_IMPORTANTE! CONSERVARE IL PRESENTE MANUALE PER FUTURO RIFERIMENTO E LEGGERLO ATTENTAMENTE.

EN

Dear customer,

Thank you for purchasing this product. So that your appliance serves you well, please read all the instructions in this user's manual. If you have any questions, please contact our customer care center.

FR

Cher client,

Nous vous remercions d'avoir acheté ce produit. Afin que vous puissiez profiter pleinement de votre appareil, veuillez lire toutes les instructions de ce manuel d'utilisation. Si vous avez la moindre question, veuillez contacter notre centre d'assistance à la clientèle.

DE

Sehr geehrter Kunde,

Vielen Dank, dass Sie dieses Produkt erworben haben. Damit Ihr Gerät Ihnen gute Dienste leistet, lesen Sie bitte alle Hinweise in diesem Benutzerhandbuch. Wenn Sie Fragen haben, wenden Sie sich bitte an unser Kundendienstzentrum.

ES

Queridos clientes,

Gracias por comprar este producto. Para que su electrodoméstico le sirva mejor, lea todas las instrucciones de este manual del usuario. Si tiene alguna pregunta, comuníquese con nuestro Centro de Atención al Cliente.

IT

Caro Cliente,

Grazie per aver acquistato questo prodotto. Per servirti meglio con questo apparecchio ti prego di leggere tutte le istruzioni in presente manuale utente. In caso di dubbio, si prega di contattare il nostro centro assistenza clienti.

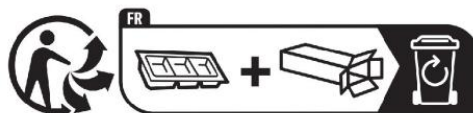

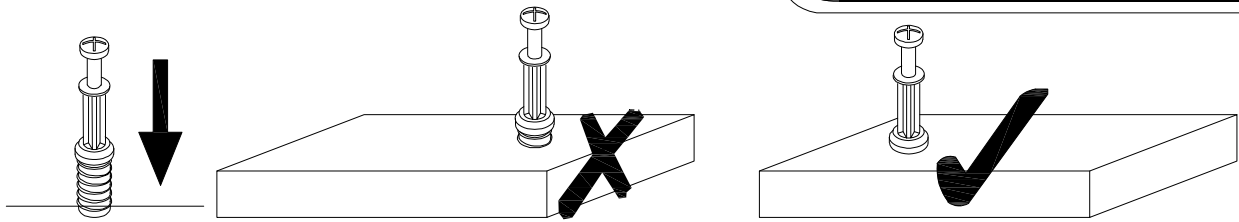

EN_QUICKFIT:Tighten quickfit until shoulder is flush with panel.Do not overtighten or undertighten.

FR_RACCORD RAPIDE:Faites serrer le raccord rapide jusqu'a ce que l'epaulement soit parfaitement encstre dans le panneau.Il ne faut ni trop serrer ni insuffisamment serrer.

ES_QUICKFIT:Apriete quickfit hasta que el hombre se descargue con el panel.NO lo sobreapriete ni lo apriete poco.

DE_QUICKFIT:Ziehen Sie den quickfit fest,bis die Schulter mit der Platte bundig ist. Bitte nicht zu fest oder zu schwach anziehen.

IT_MONTAGGIO RAPIDO:Stringere il montaggio rapido fino aquando la spalla e a filo con il pannello,non stringere troppo o troppo poco.

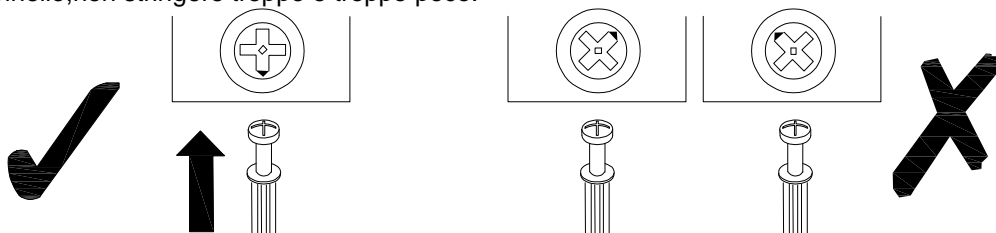

EN_CAM LOCK:When fitting cam lock,ensure starting position is correct before you insert connecting quickfit.

FR_SERRURE BATTEUSE:Avant d'insérer la serrure batteuse,veillez a la bonne orientation avant d'insérer le raccord rapide,

ES_CIERRE DE LA CAMARA:Cuando instale el cierre de la camara,asegurese de que la posicion de inicio es correcta antes de que inserte el quickfit conector,

De_CAM-LOCK:Achten Sie bei der Montage des Cam-locks auf die richtige Ausgangsposition,bevor Sie den Quickfit einsetzen.

IT_BLOCCAGGIO A CAMMA:Quando si monta il bloccaggio a camma,assicurarsi che la posizione iniziale sia corretta prima di inserire il montaggio rapido di collegamento.

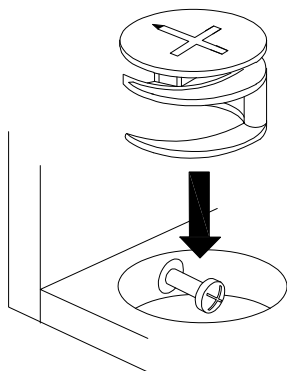

EN_Quickfit head should be in the centre of the cam lock when the two panels are joined.

Cam lock should be inserted before quickfit.

FR_Lorsque les deux panneaux sont assembles,la tete du raccord rapide doit reposer au centre de la serrure batteuse. Il faut inserer la serrure batteuse avant le raccord rapide.

ES_EL cabezal del quickfit debe estar en el centro del cierre de la camara cuando se unan los dos paneles.

Se debe insertar el cierre de la camara antes que el quickfit.

DE_Der Quickfit-Kopf sollte sich in der Mitte des Cam-locks befinden,wenn die beiden Platten zusammengefugt sind.

Der Cam-lock sollte vor dem Quickfit eingesetzt werden.

IT_La testa del montaggio rapido deve trova rsi al centro del bloccaggio a camma quando i due pannelli sono uniti.

Il Bloccaggio a Camma deve essere inserito prima del montaggio rapido.

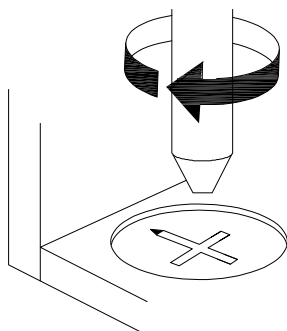

EN_Turn cam lock clockwise to tighten.

FR_Faites tourner la serrure batteuse dans le sens des aiguilles d'une montre pour la resserrer.



ES_Gire el cierre de la camara en sentido horario para apretarlo.

DE_Drehen Sie den Cam-Lock im Uhrzeigersinn,um ihn festzuziehen.

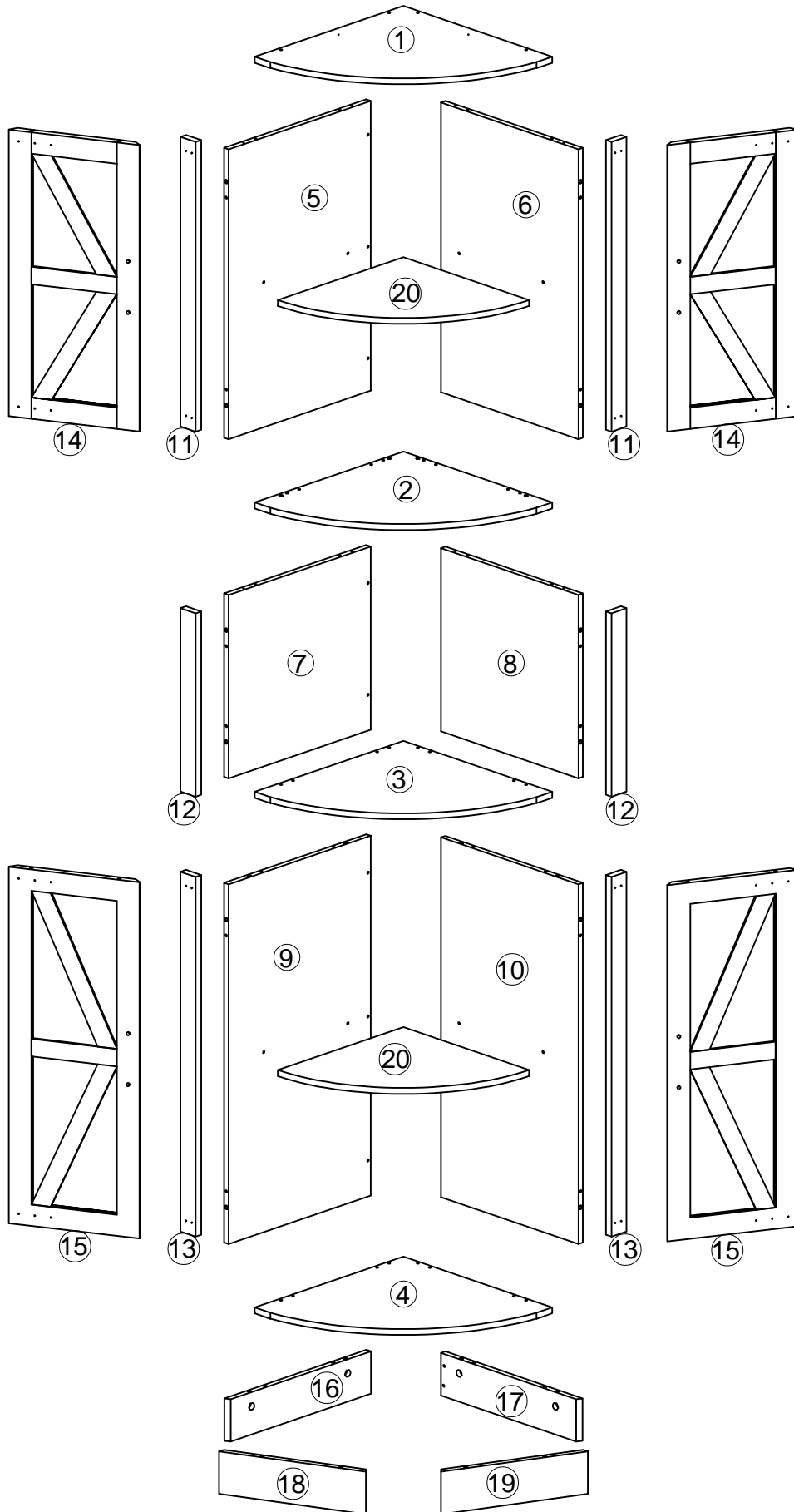
IT_Rutotare il bloccaggio a camma in senso oragio per stringere.

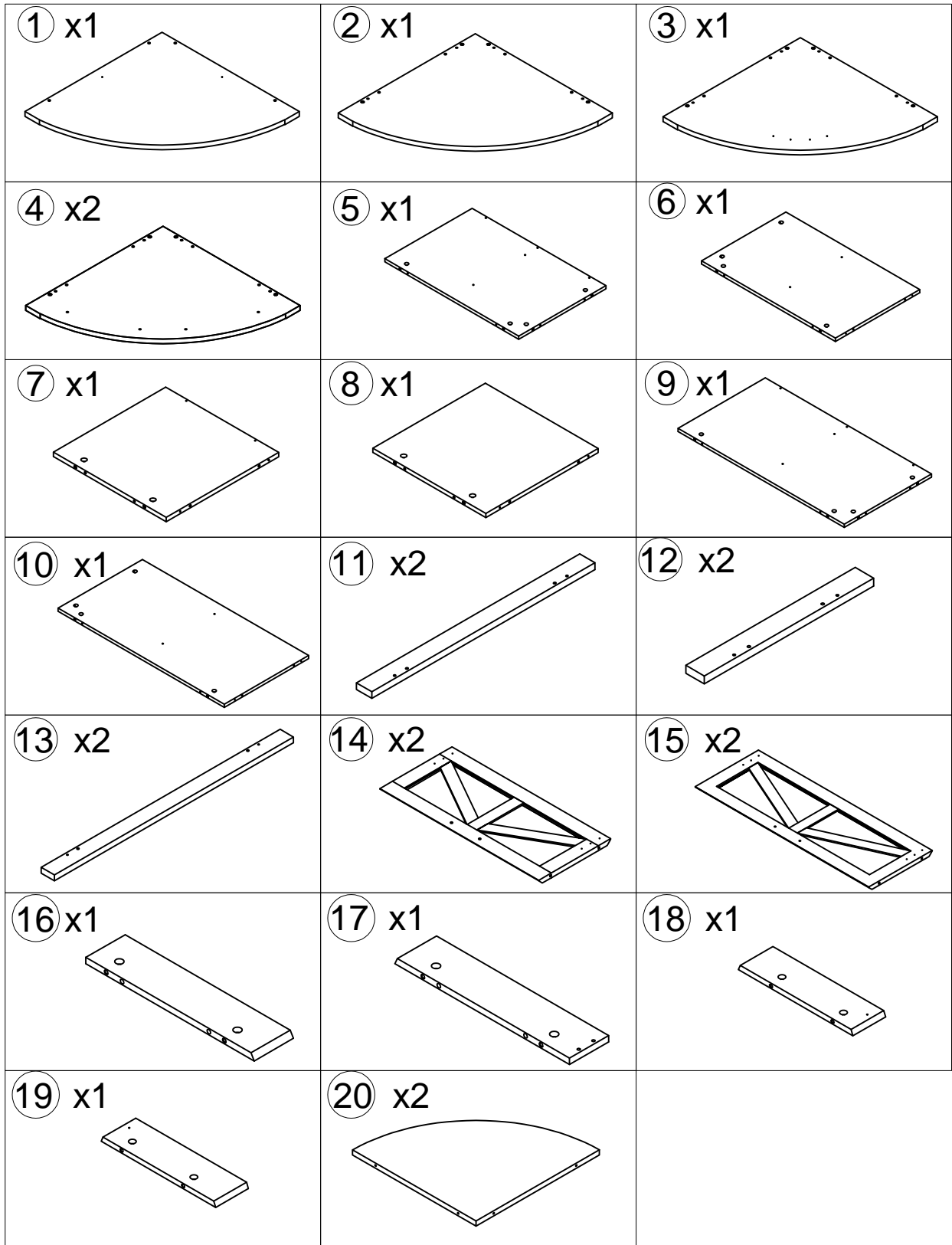

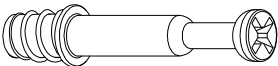
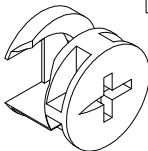

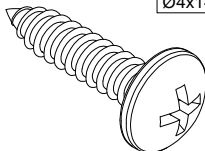
<p>A x25+3 Ø6x35mm</p> 	<p>B x25+3 Ø15*10mm</p> 	<p>C x37+3 Ø6x30mm</p> 	<p>D x32+3 Ø4x14mm</p> 
---	--	--	---

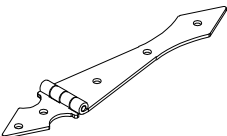
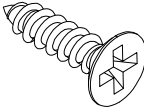
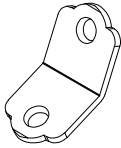
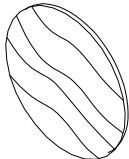
<p>E x8 142x24x6mm</p> 	<p>F x14+3 Ø3.5x12mm</p> 	<p>G x1</p> 	<p>H x18+2</p> 
---	---	--	---

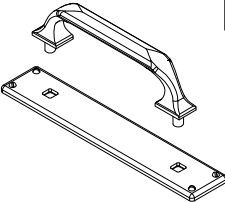
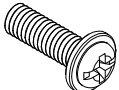
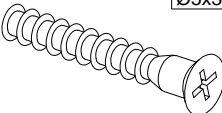
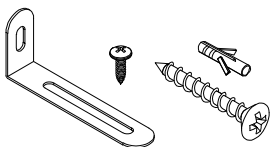
<p>I x4</p> 	<p>J x8+2 M4x12mm</p> 	<p>K x34+3 Ø5x38mm</p> 	<p>L x2</p> 
--	--	--	--

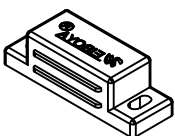
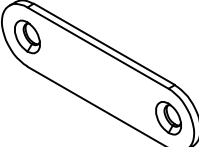
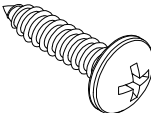
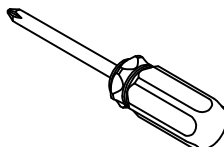
<p>M x4</p> 	<p>N x6</p> 	<p>O x8+2 Ø3x16mm</p> 	<p>x1</p> 
--	--	---	---

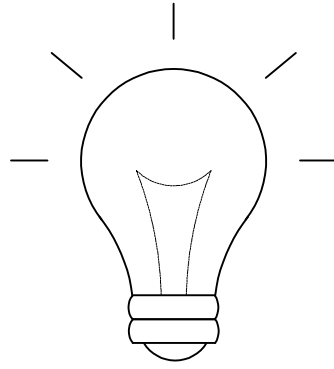

friendly reminder

To avoid errors and confusion during the installation of accessories, use the type and quantity of hardware accessories according to the installation procedure described in the instructions. First, unroll the accessories bag and lay out the hardware accessories, cut holes in the side, and take out the hardware accessories

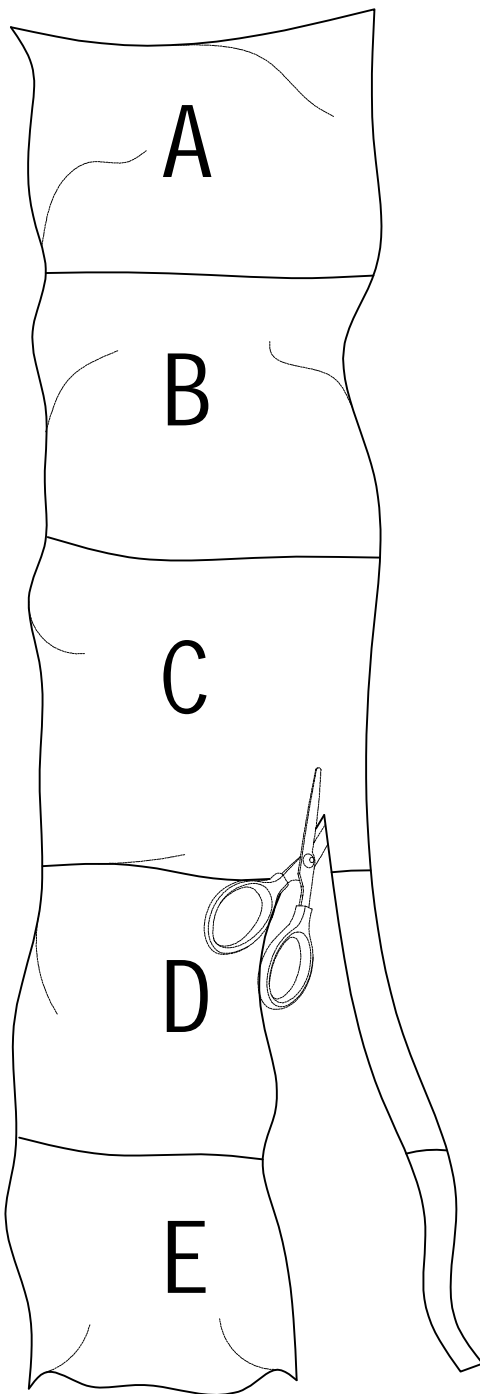

1

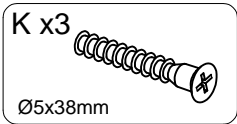
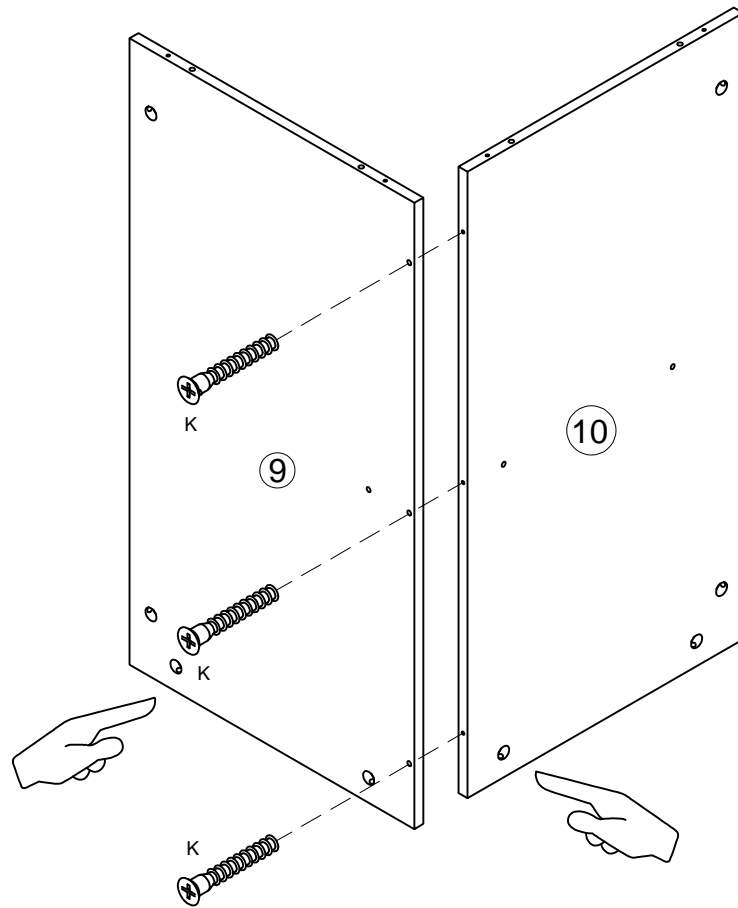

2

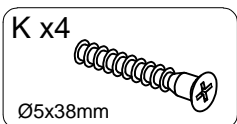
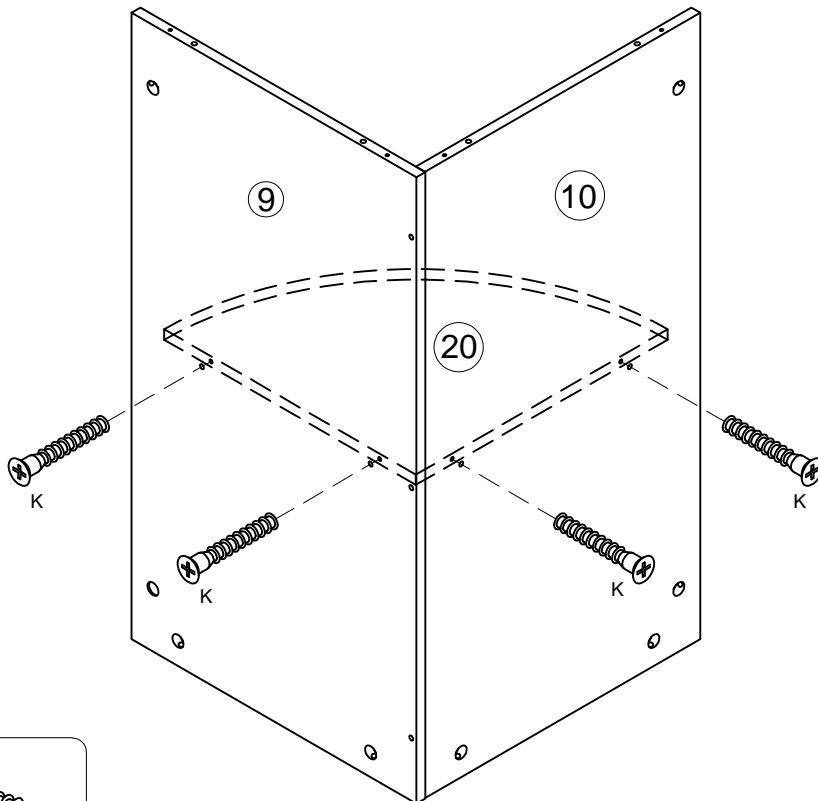

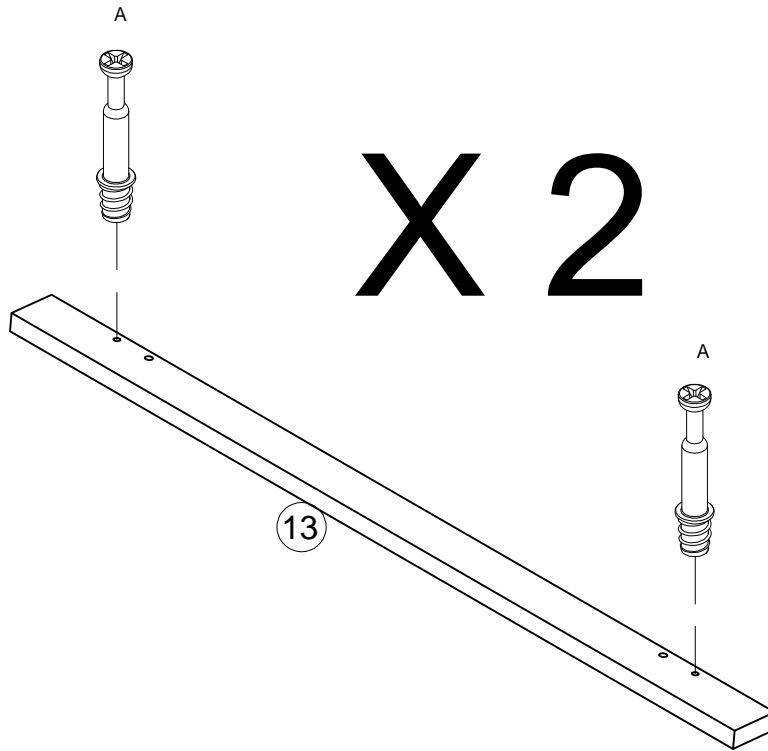

X 2

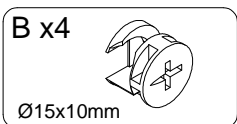
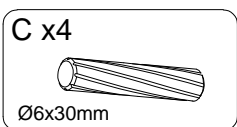
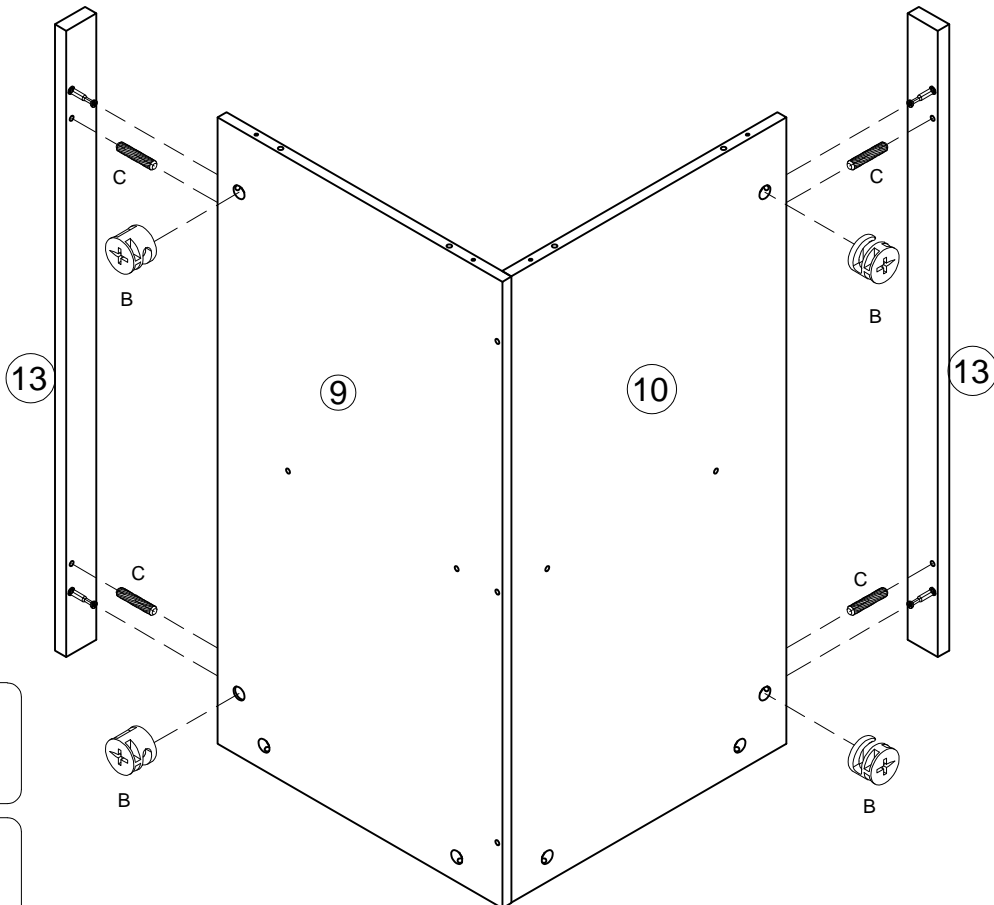
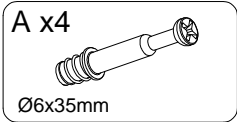

5

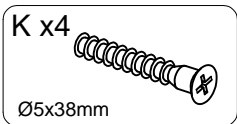
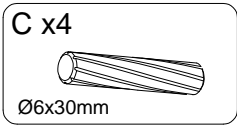
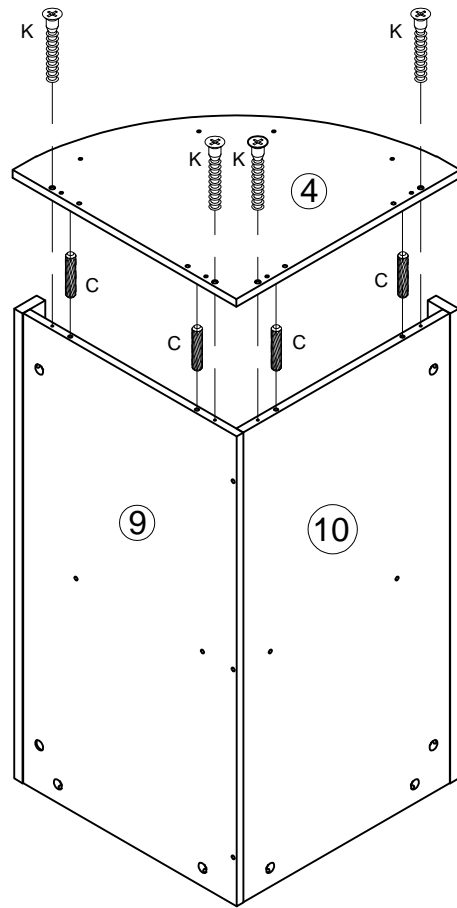

6

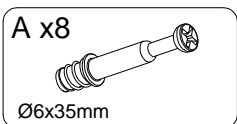
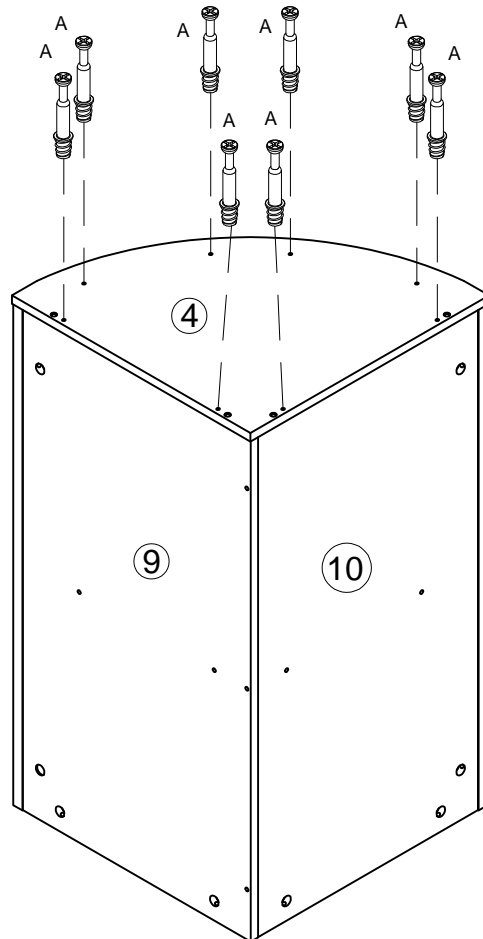

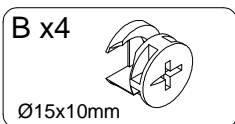
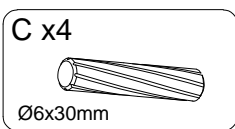
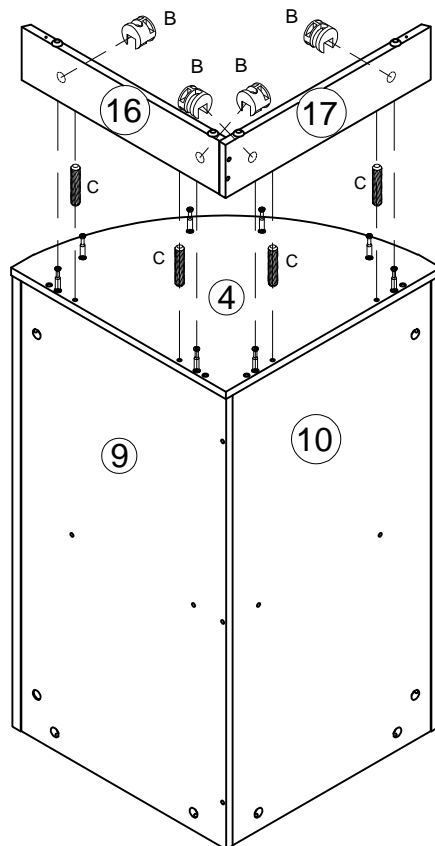
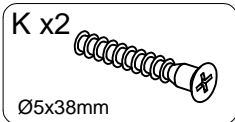
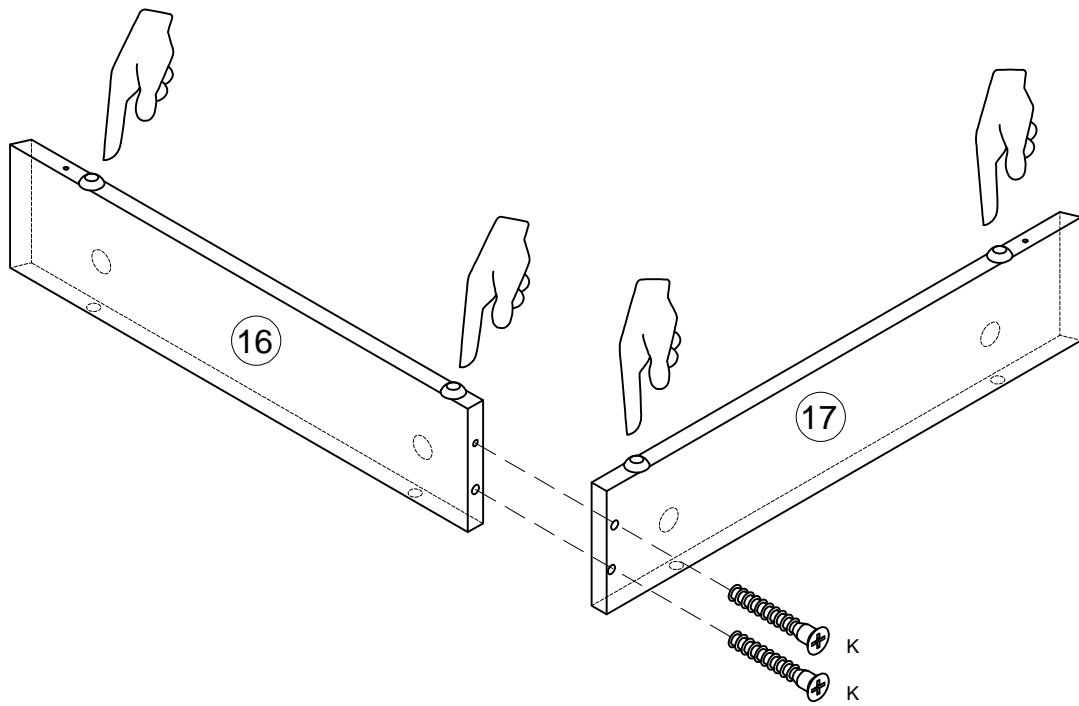

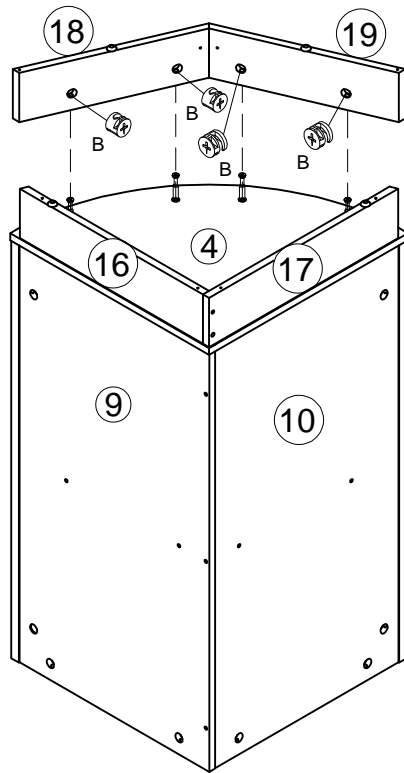

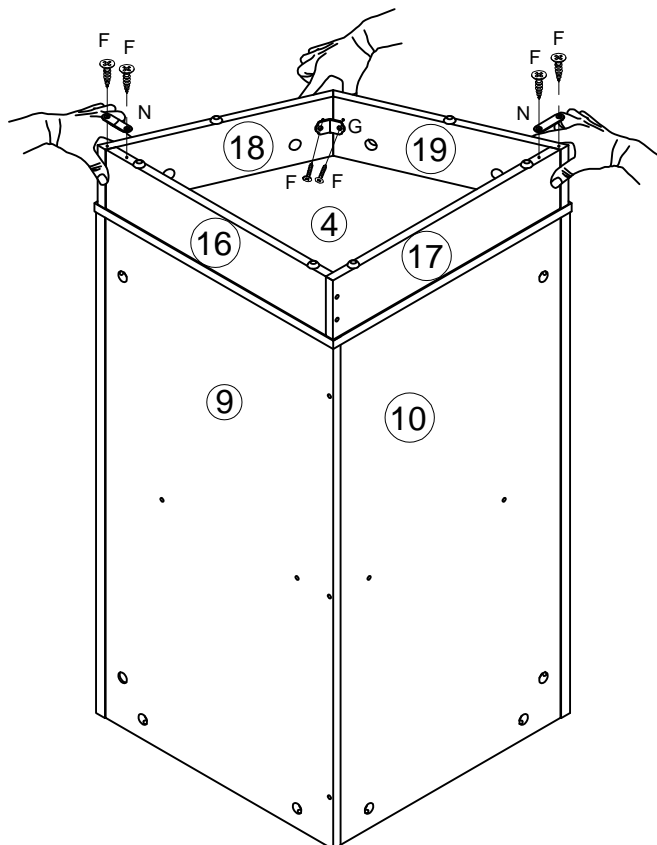

B x4

 Ø15x10mm

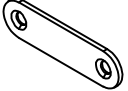

G x1

F x6

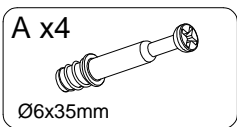
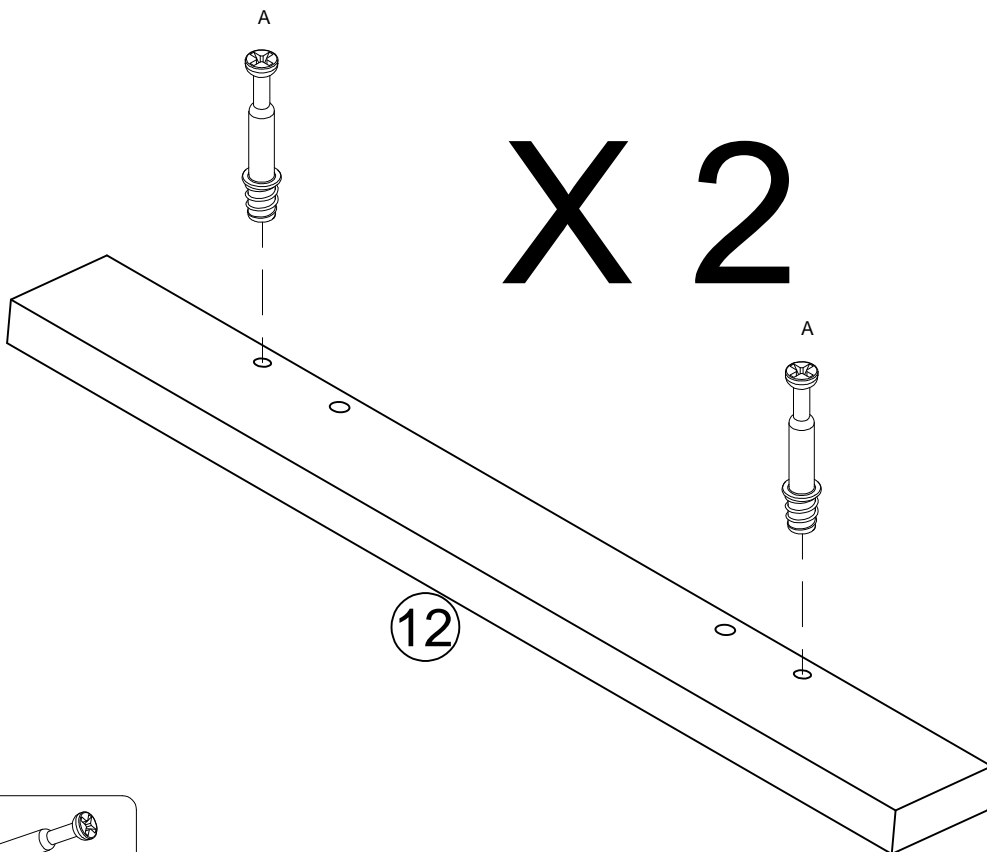
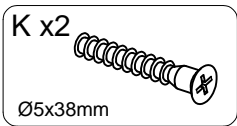
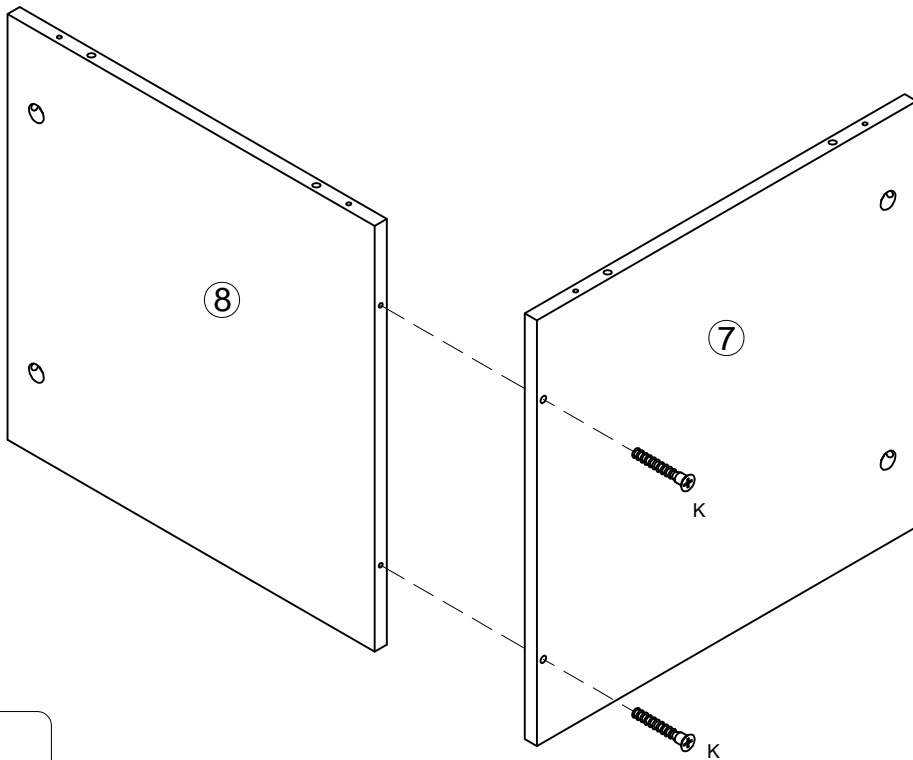
 3.5x12mm

N x2

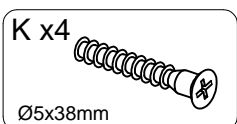
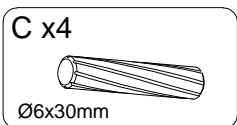
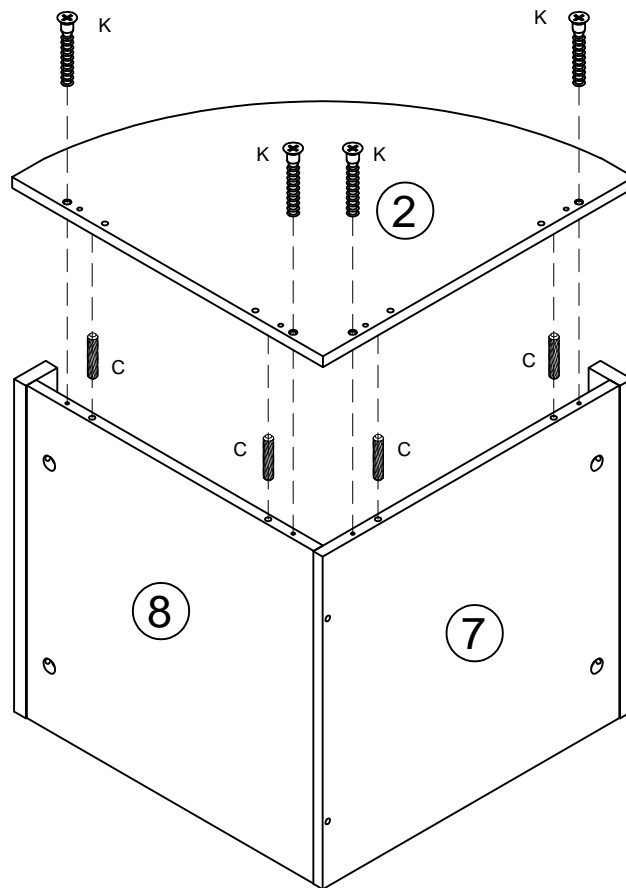
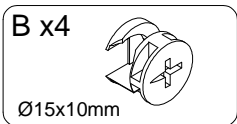
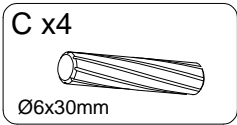
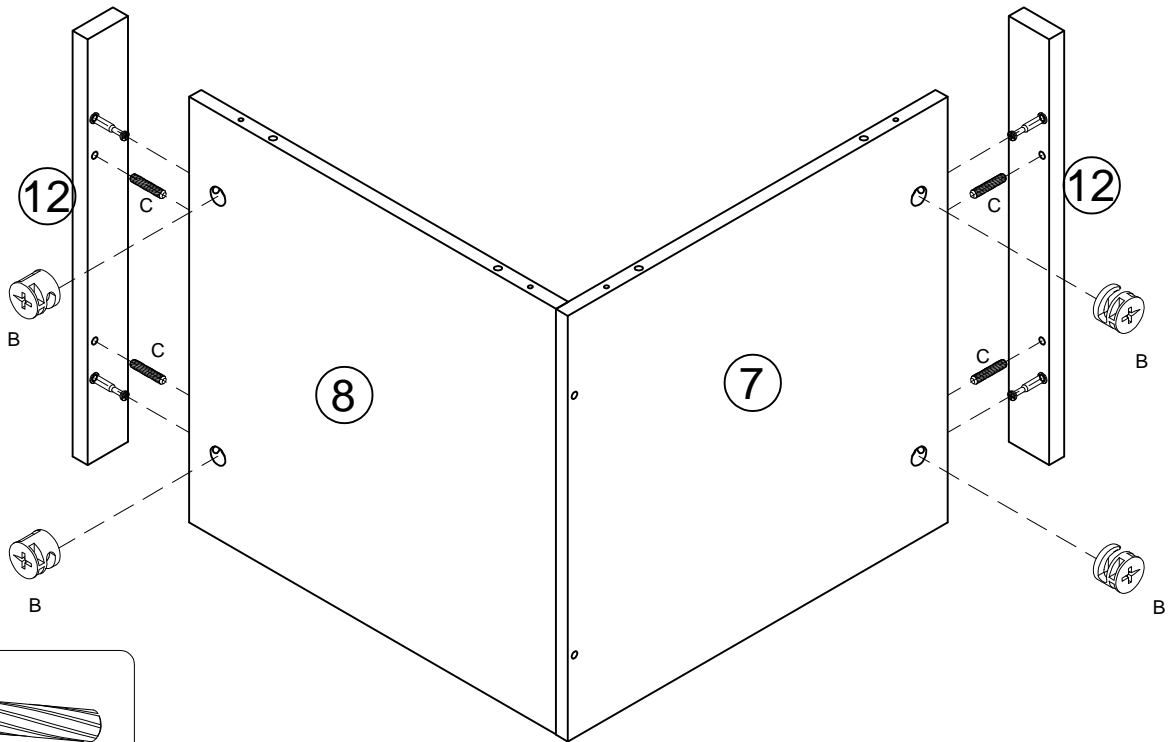

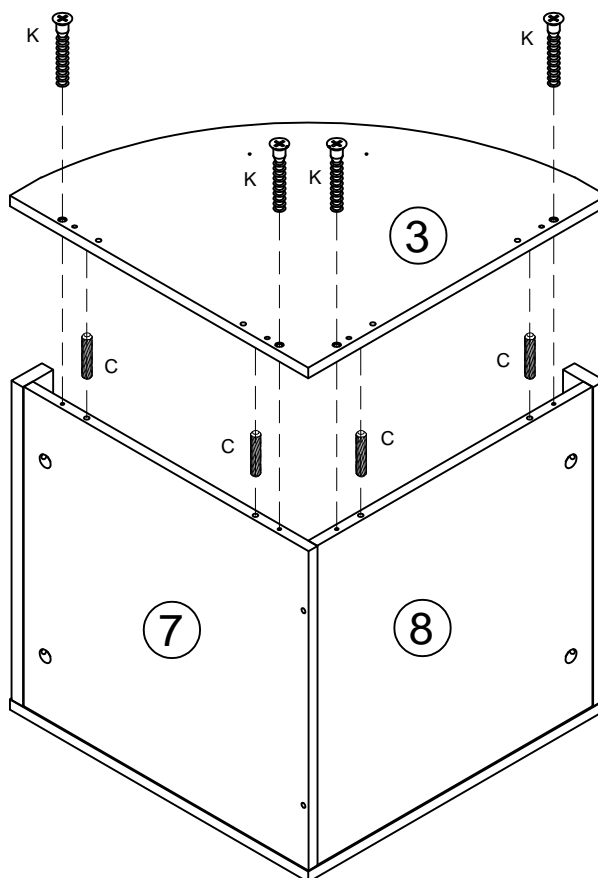
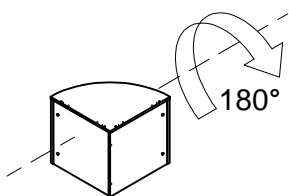



C x4



Ø6x30mm

K x4

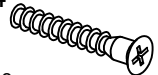

Ø5x38mm

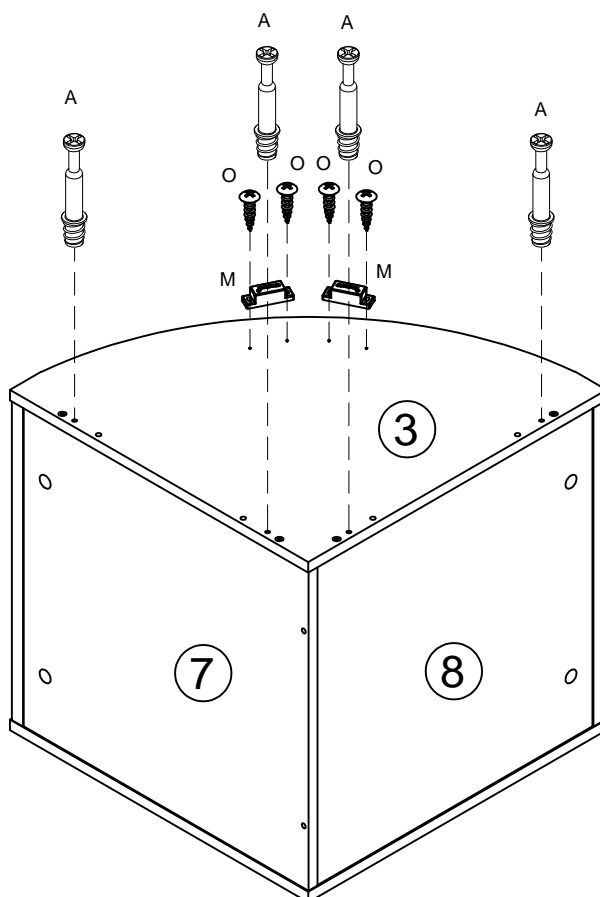

O x4

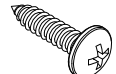

Ø3x16mm

M x2

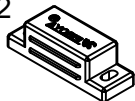

A x4



Ø6x35mm

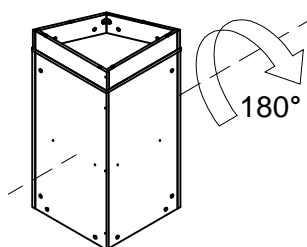
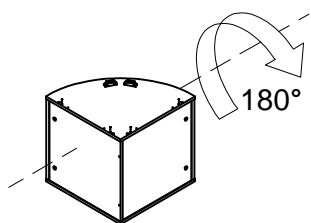

C x4

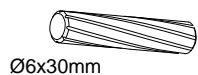

B x4

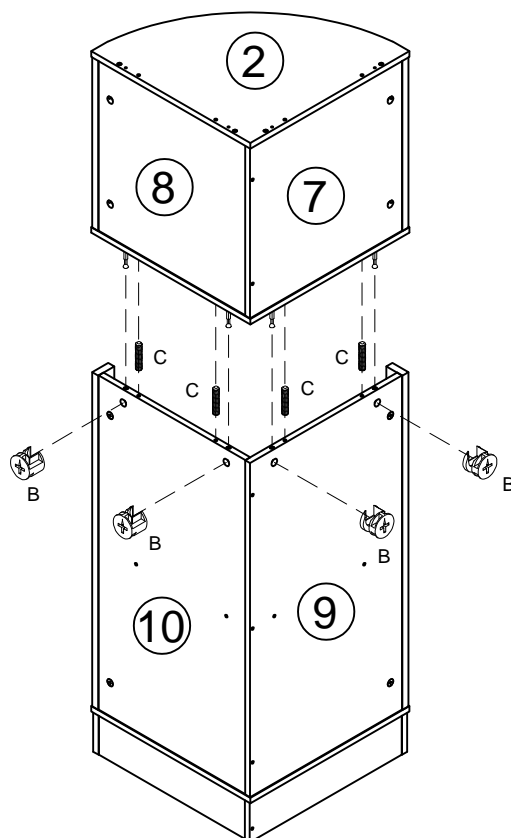
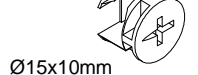

A x4

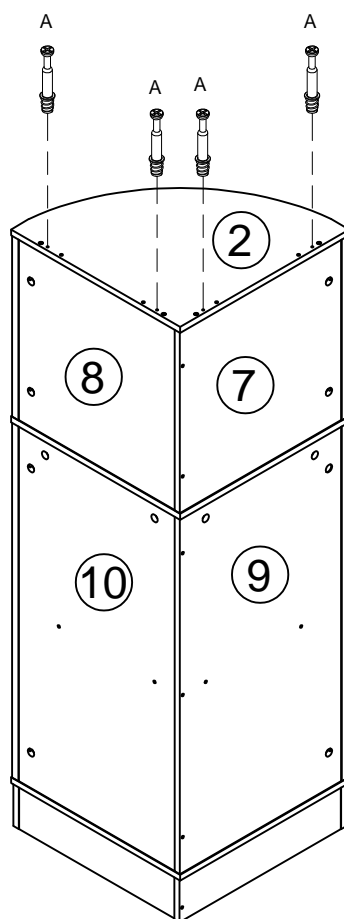
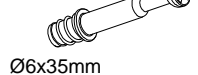

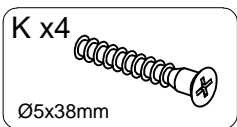
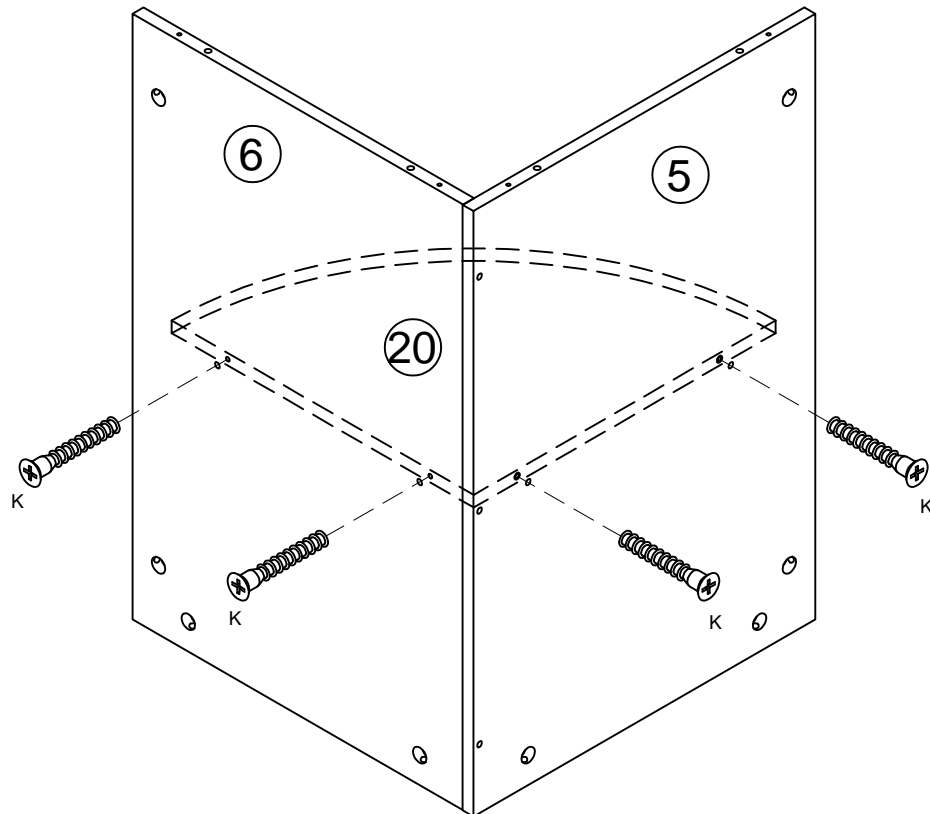
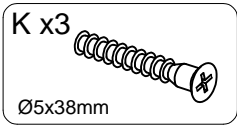
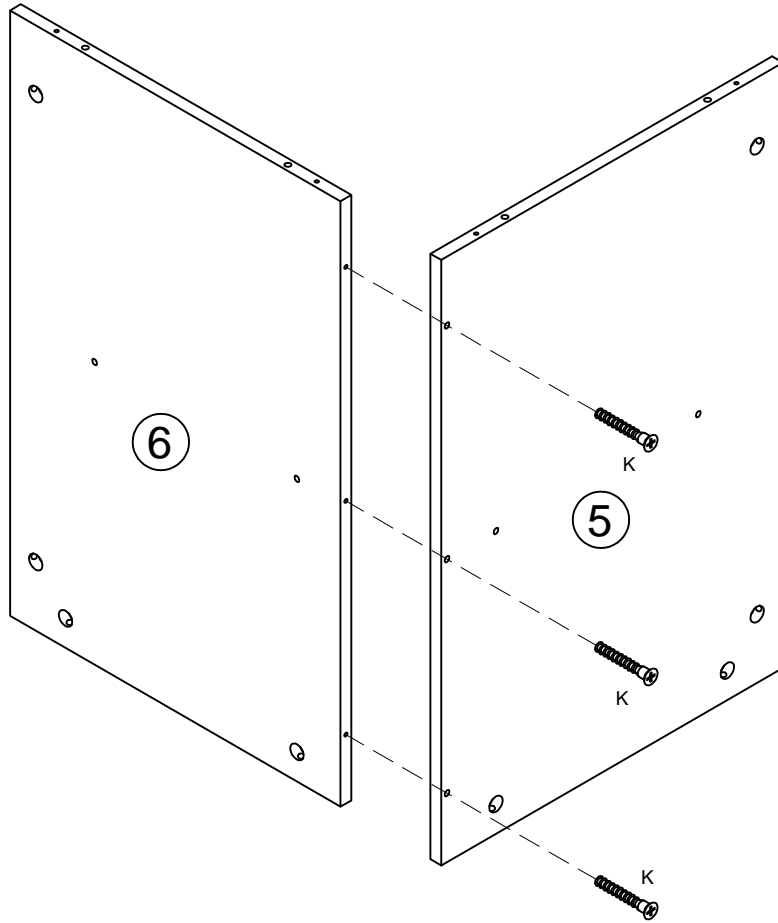

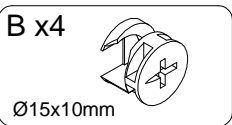
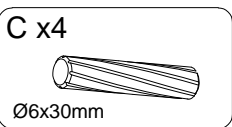
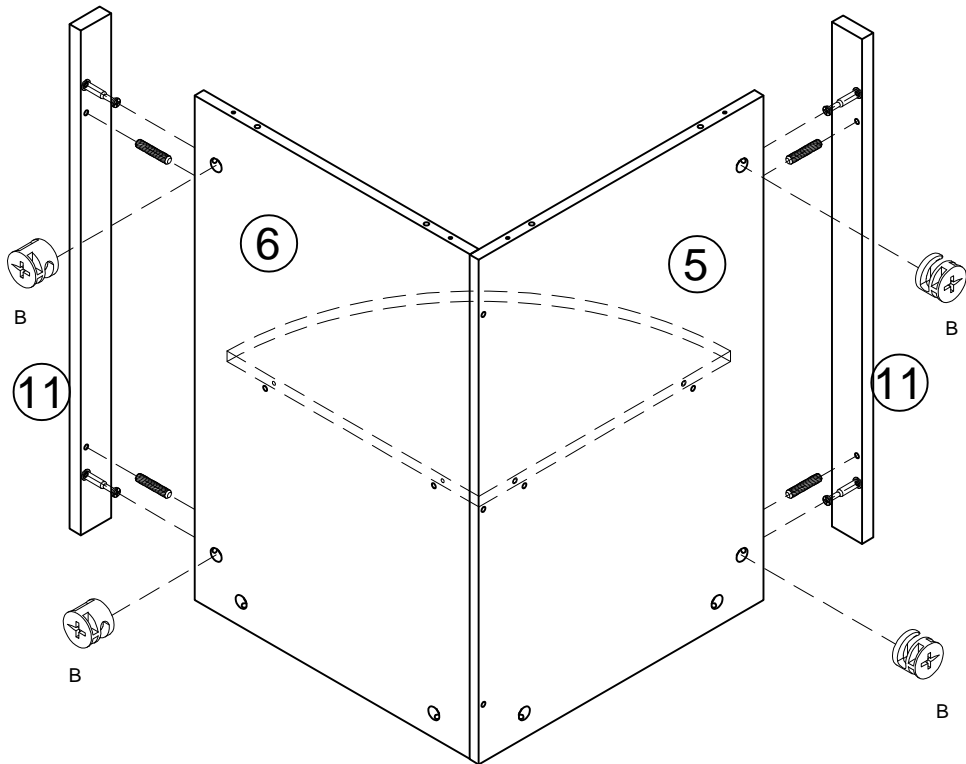
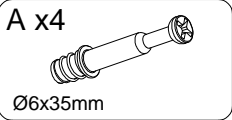
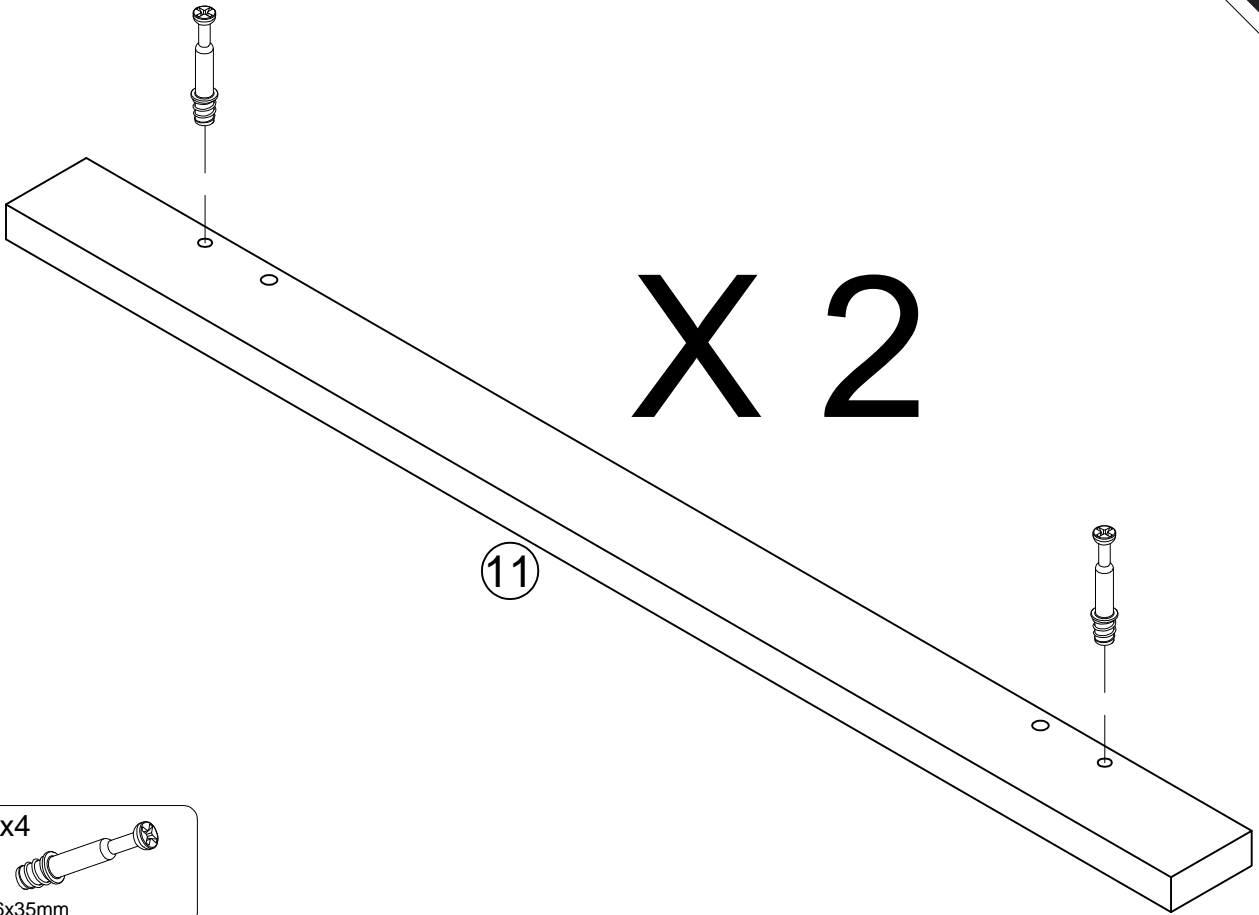

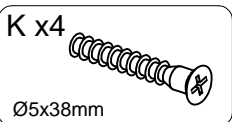
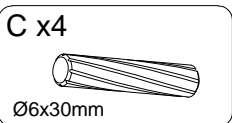
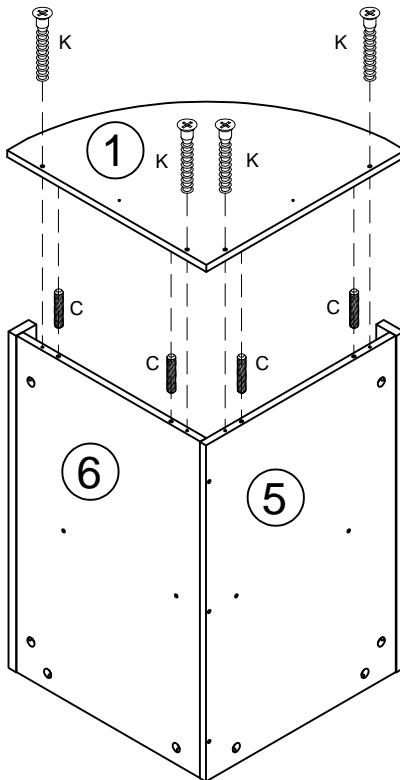
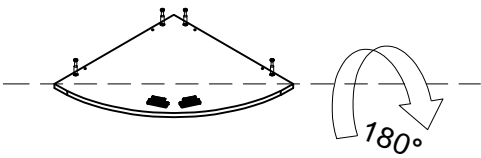
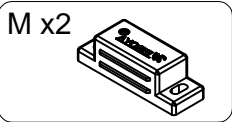
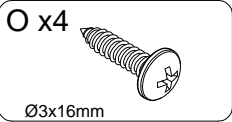
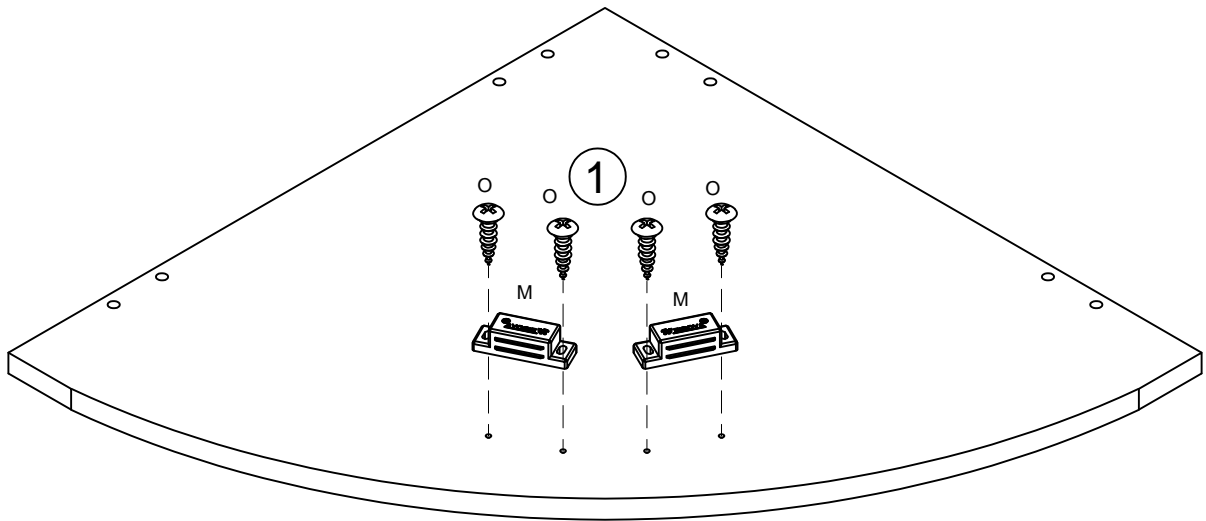

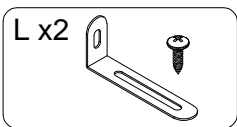
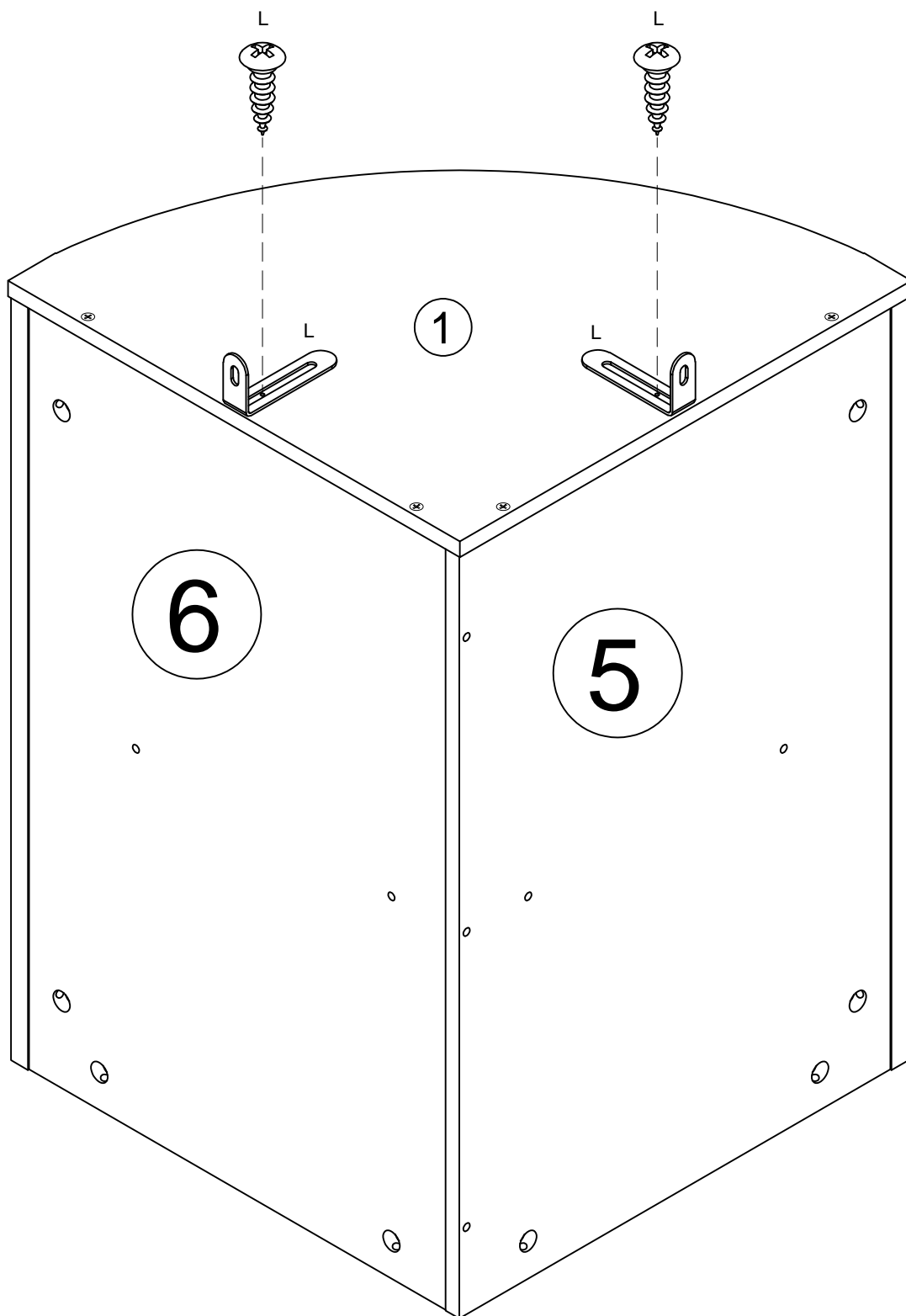

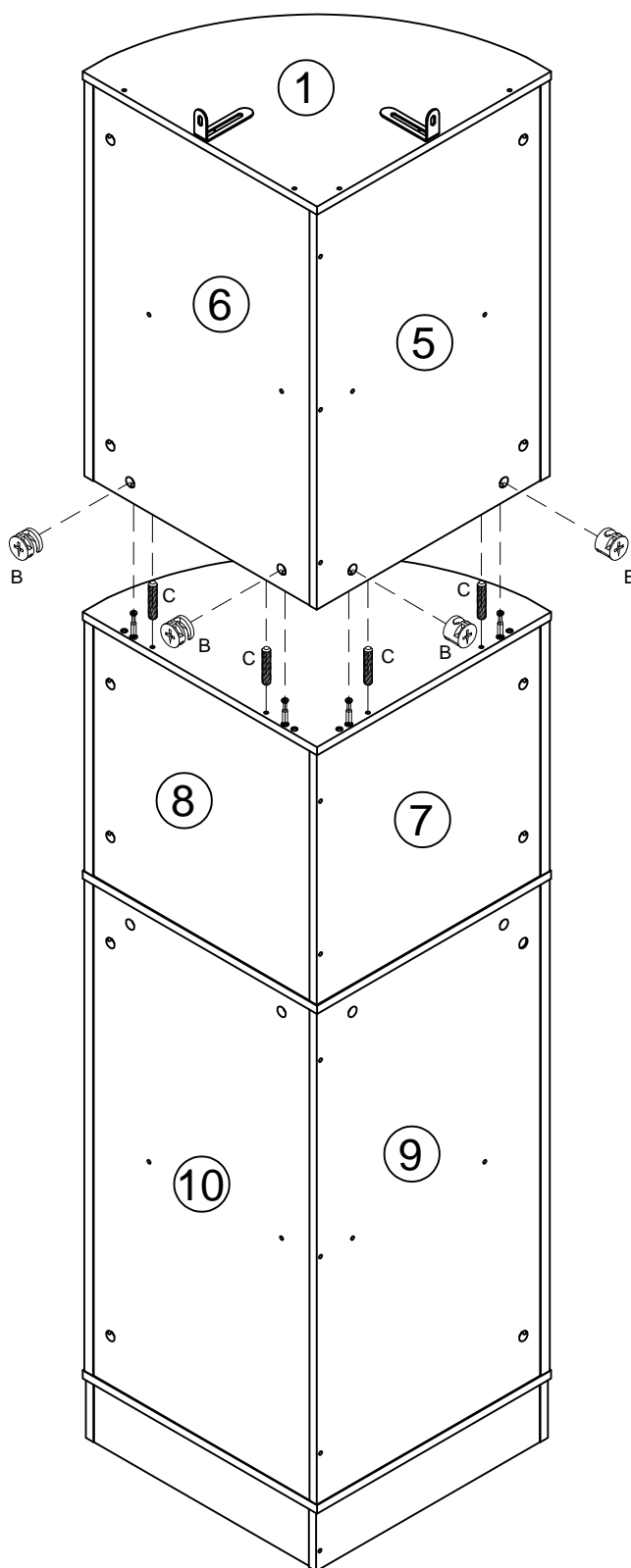

C x4



Ø6x30mm

B x4



Ø15x10mm

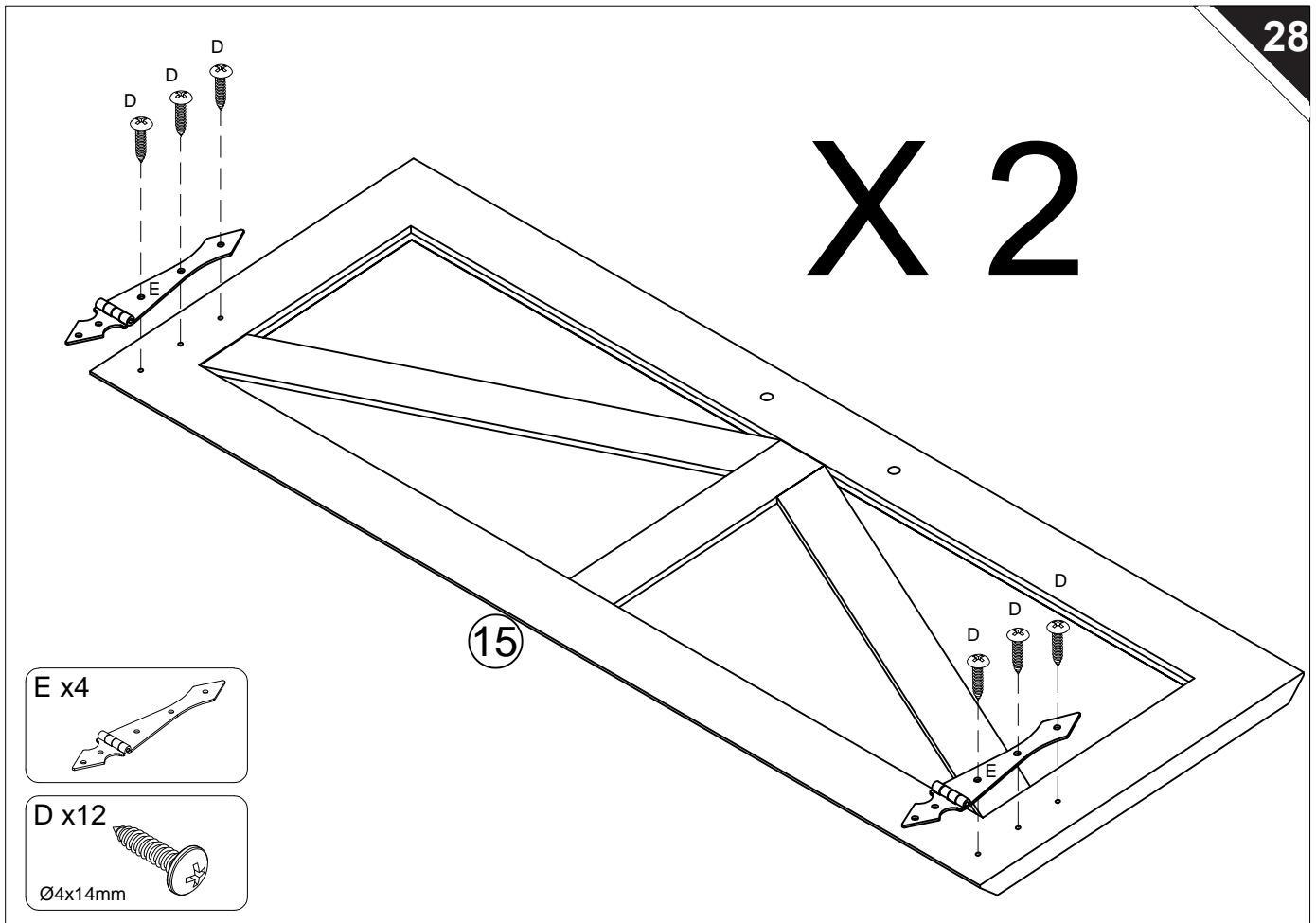
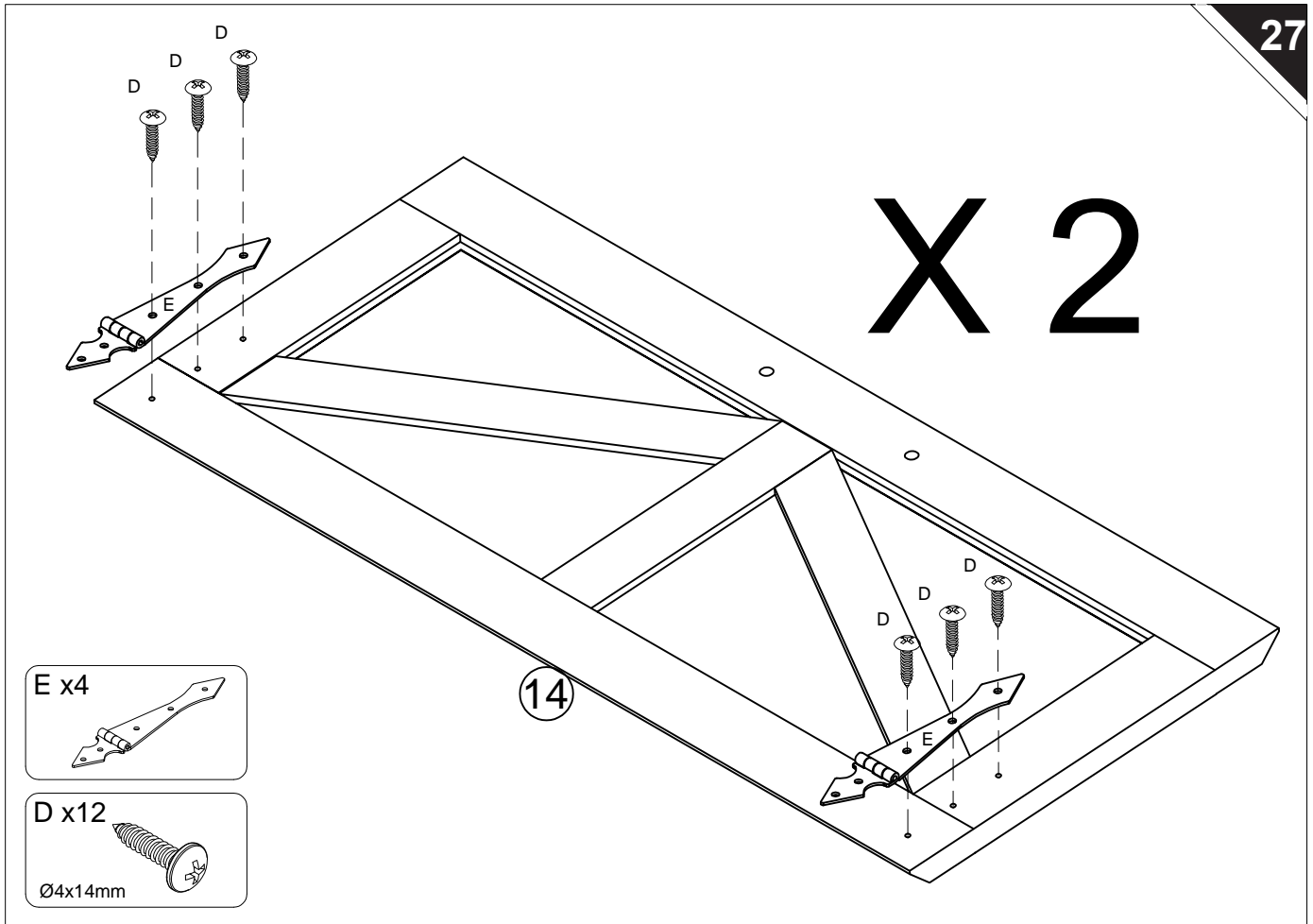

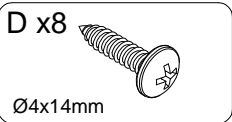
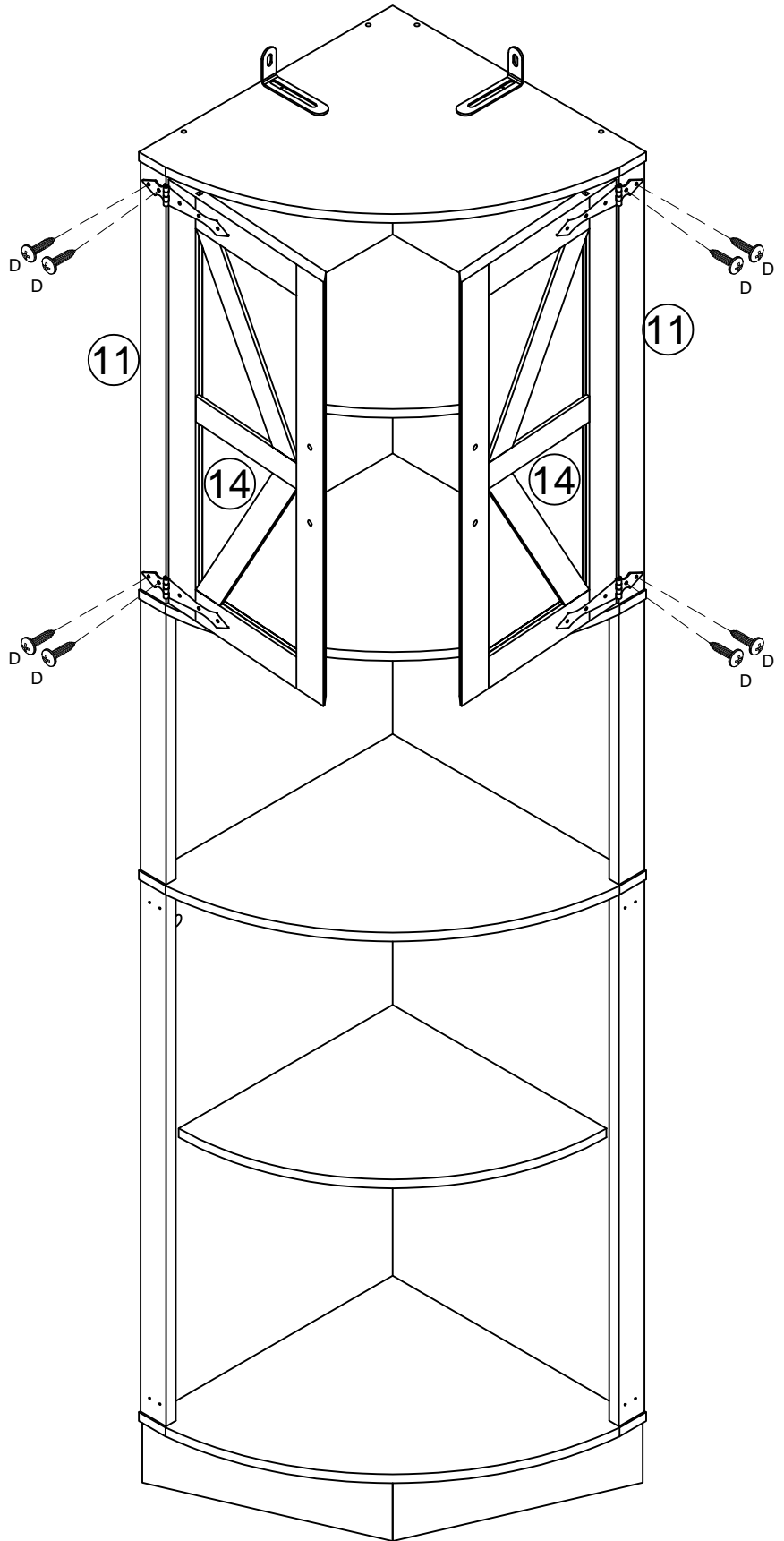
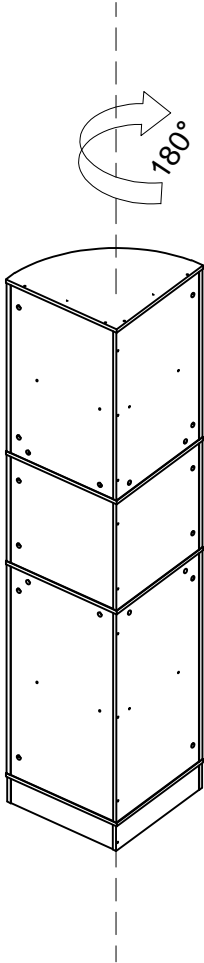

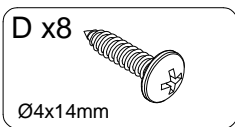
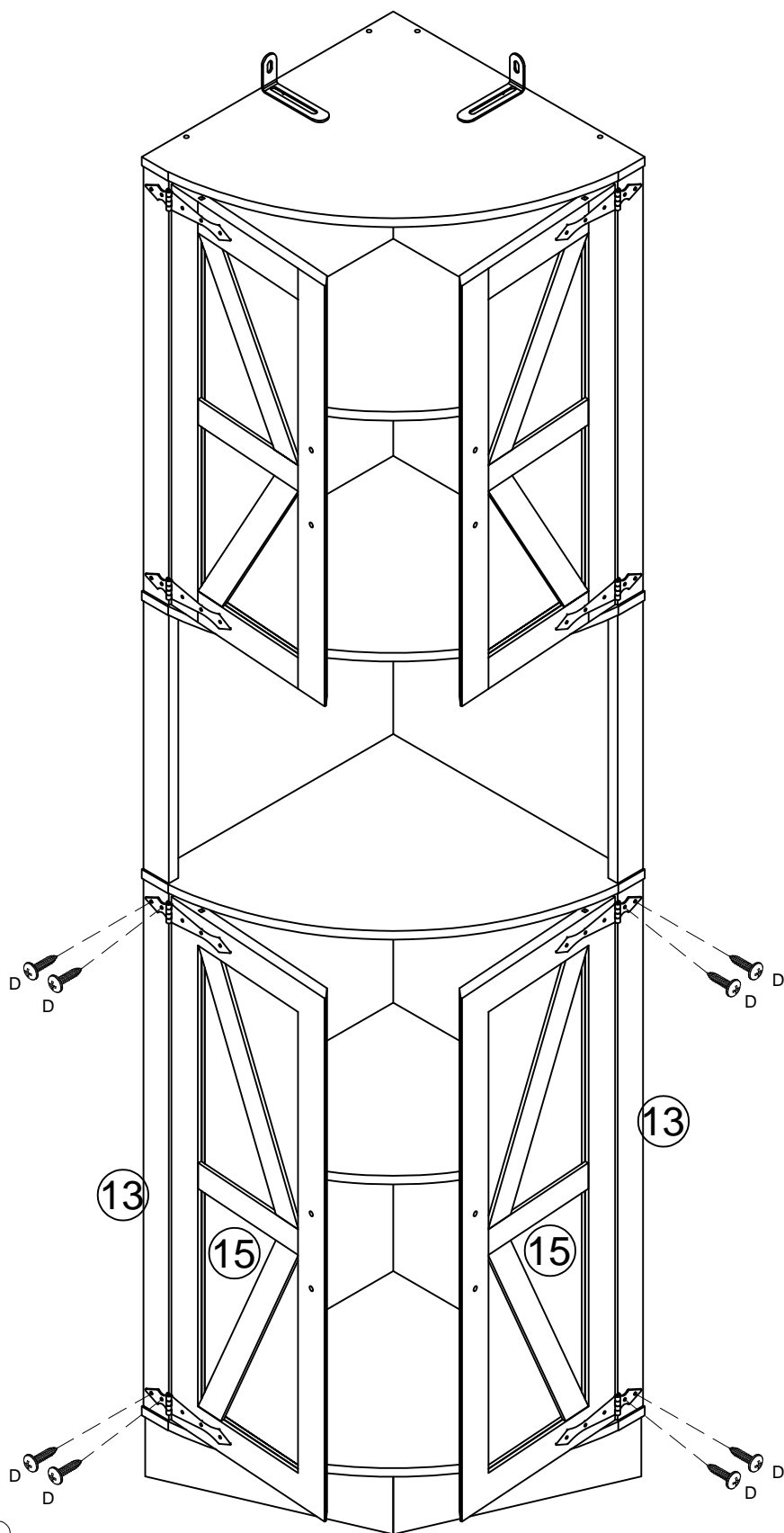

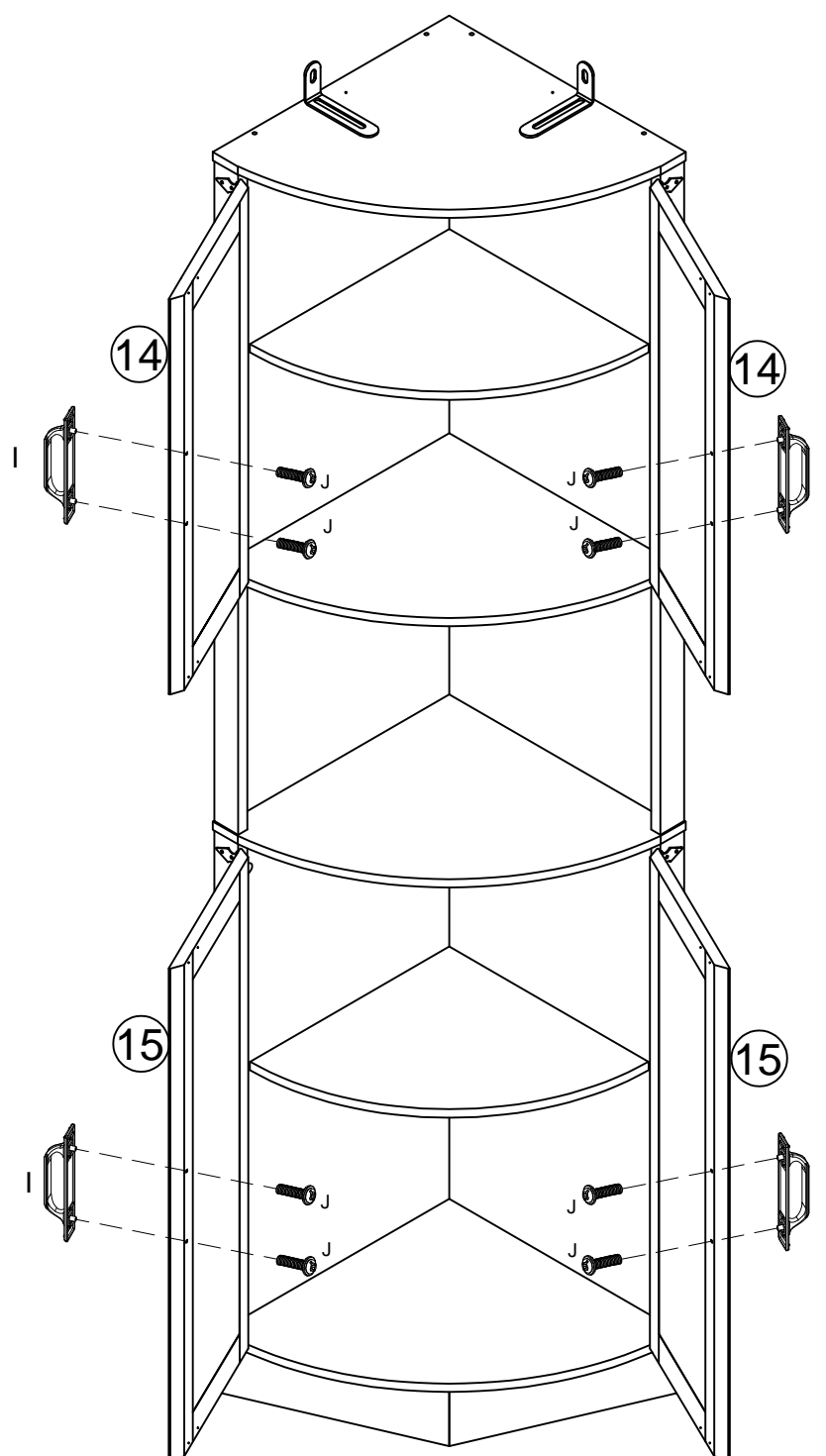

J x8



M4x12mm

I x4

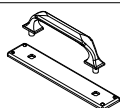

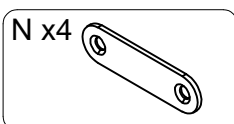
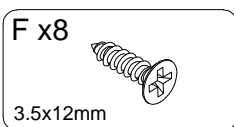
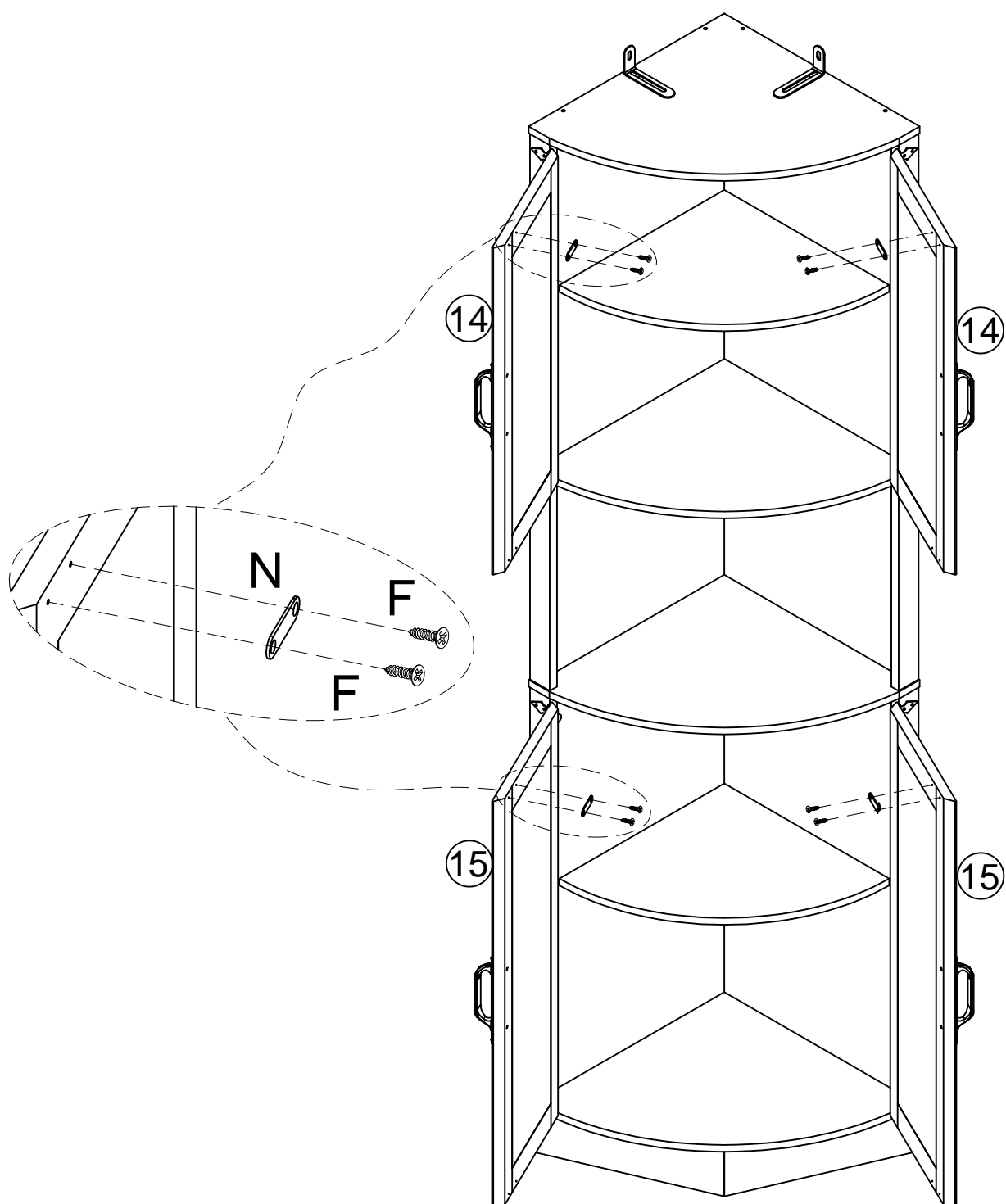

EN

The sideboard must be permanently secured to the wall using the supplied anti-tip device to prevent the sideboard from tipping over. Mark the drill locations on the wall with a pencil. Drill holes at the marked locations with a drill bit and then use a hammer to gently insert the wall anchors (M) into the drilled holes. Secure the sideboard to the wall with the screws (M) provided.

FR

Le buffet doit être fixé de manière permanente au mur à l'aide du dispositif anti-basculé fourni afin d'éviter qu'il ne bascule. Marquez les positions de perçage sur le mur à l'aide d'un crayon. Percez des trous aux emplacements marqués à l'aide d'une perceuse, puis utilisez un marteau pour insérer délicatement les chevilles (M) dans les trous percés. Fixez le buffet au mur à l'aide des vis (M) fournies.

DE

Das Sideboard muss mit der mitgelieferten Kippsicherung dauerhaft an der Wand befestigt werden, um ein Umkippen des Sideboards zu verhindern. Markieren Sie die Bohrstellen an der Wand mit einem Bleistift. Bohren Sie an den markierten Stellen mit einem Bohrer Löcher und setzen Sie dann die Maueranker (M) mit einem Hammer vorsichtig in die Bohrlöcher ein. Befestigen Sie das Sideboard mit den mitgelieferten Schrauben (M) an der Wand.

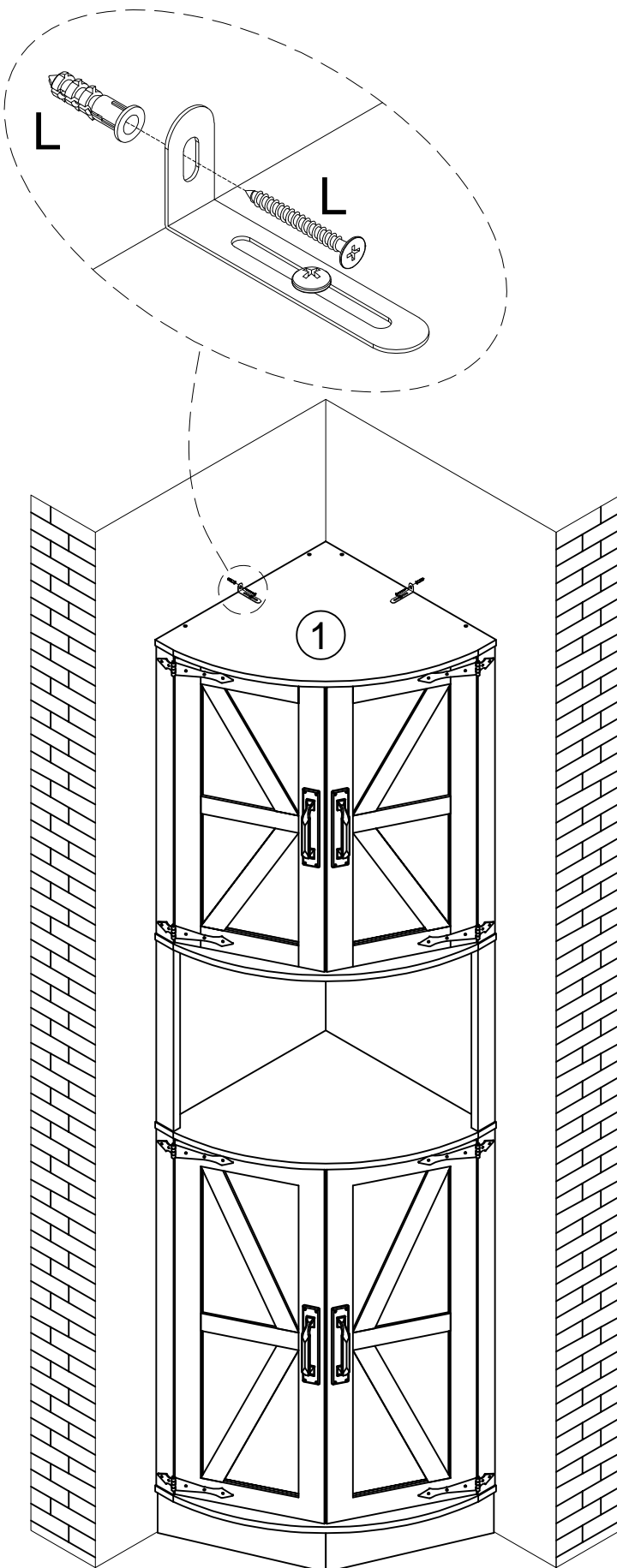
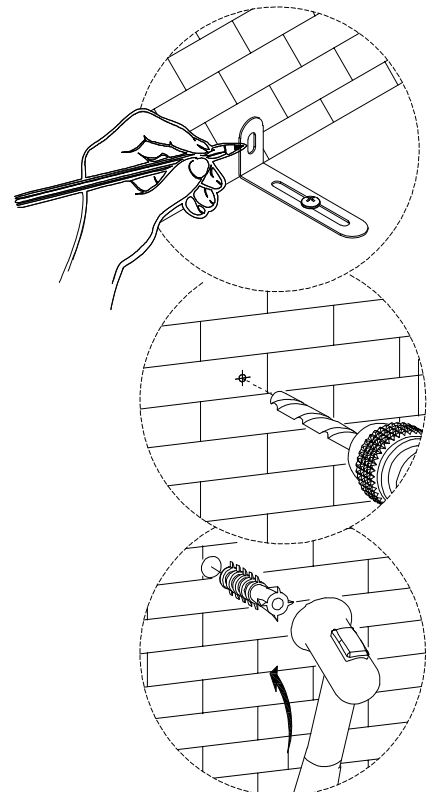

L x2

