

Step 1 : First place both coffee table tops upside down on clean surface, then align the base upwards and also align the position of the base holes and D-nuts upwards.

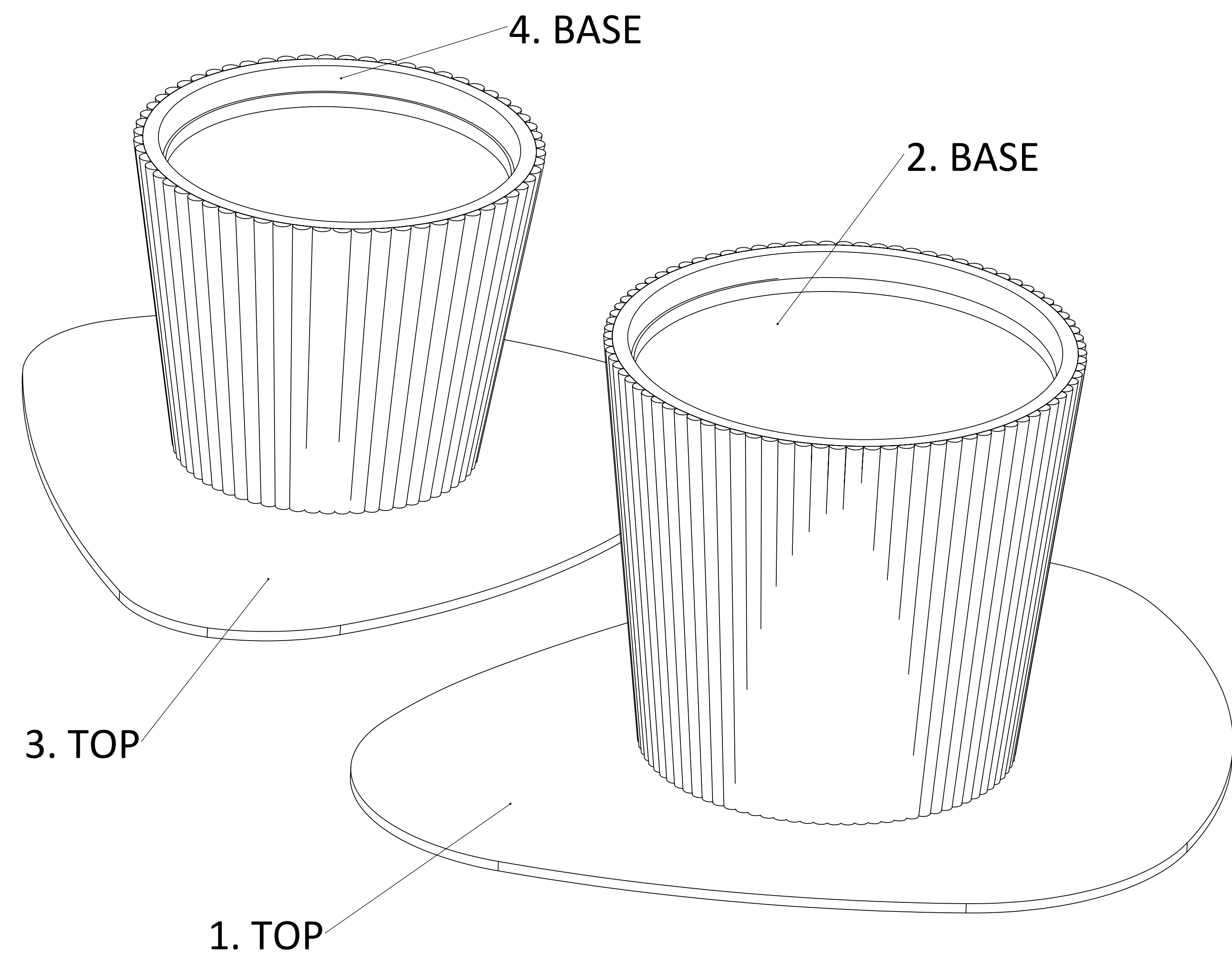

Step 2 : Now, Tight the base on the top using 2 allen bolt with washer using allen key as per figure below. (For Big coffee table)

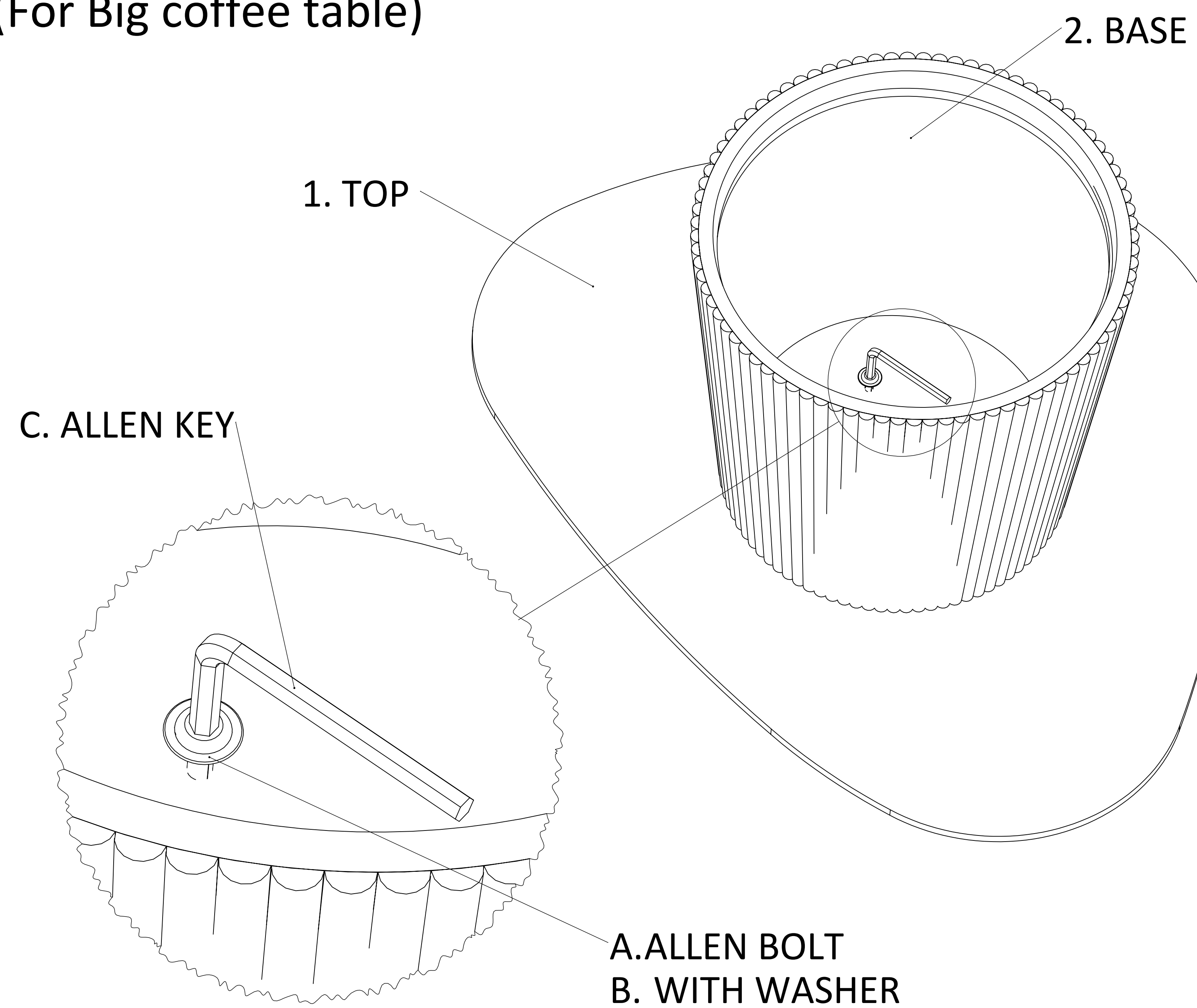

Step 3 : Now, Repeat Step 2 for small coffee table.

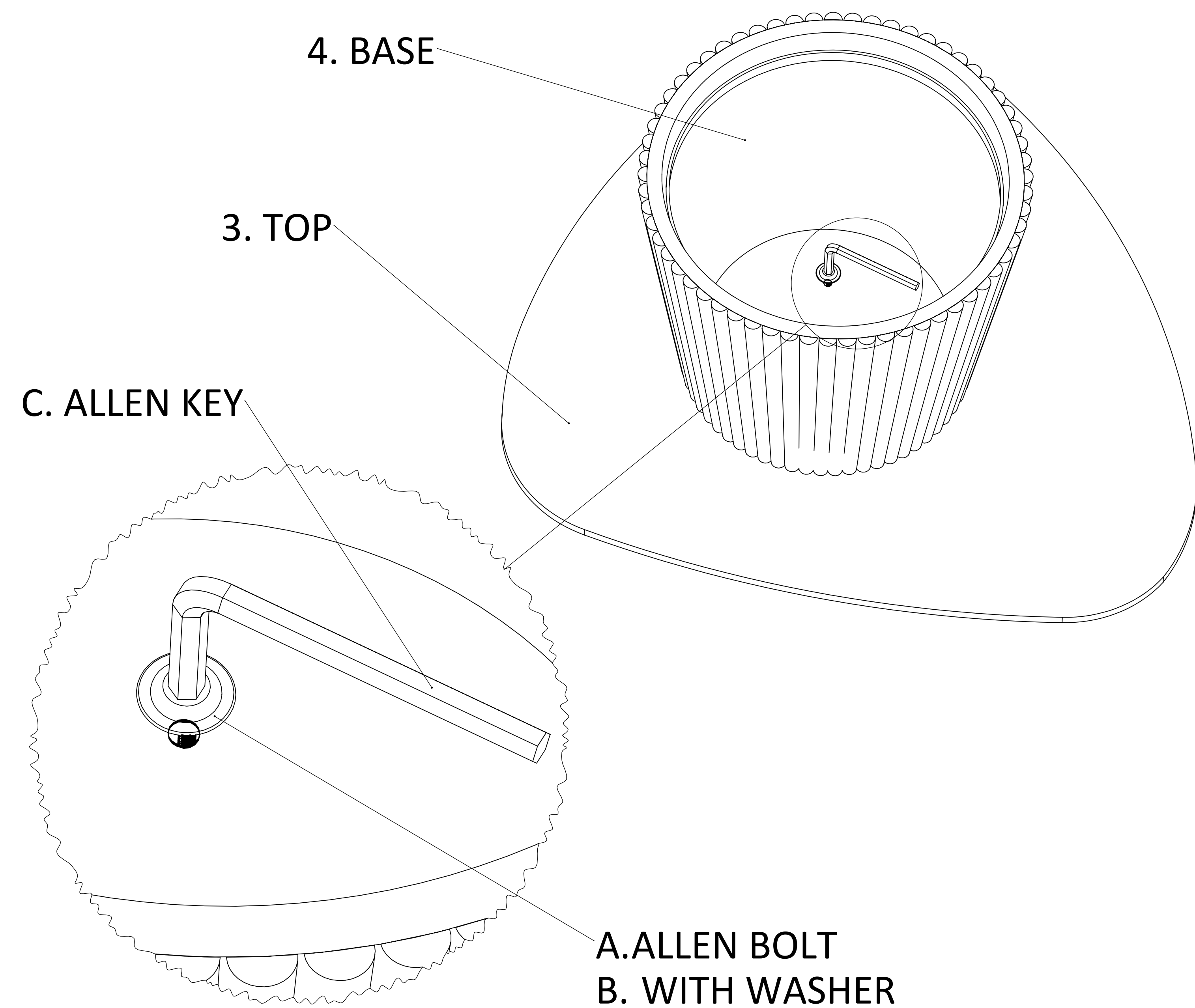

FINAL PRODUCT

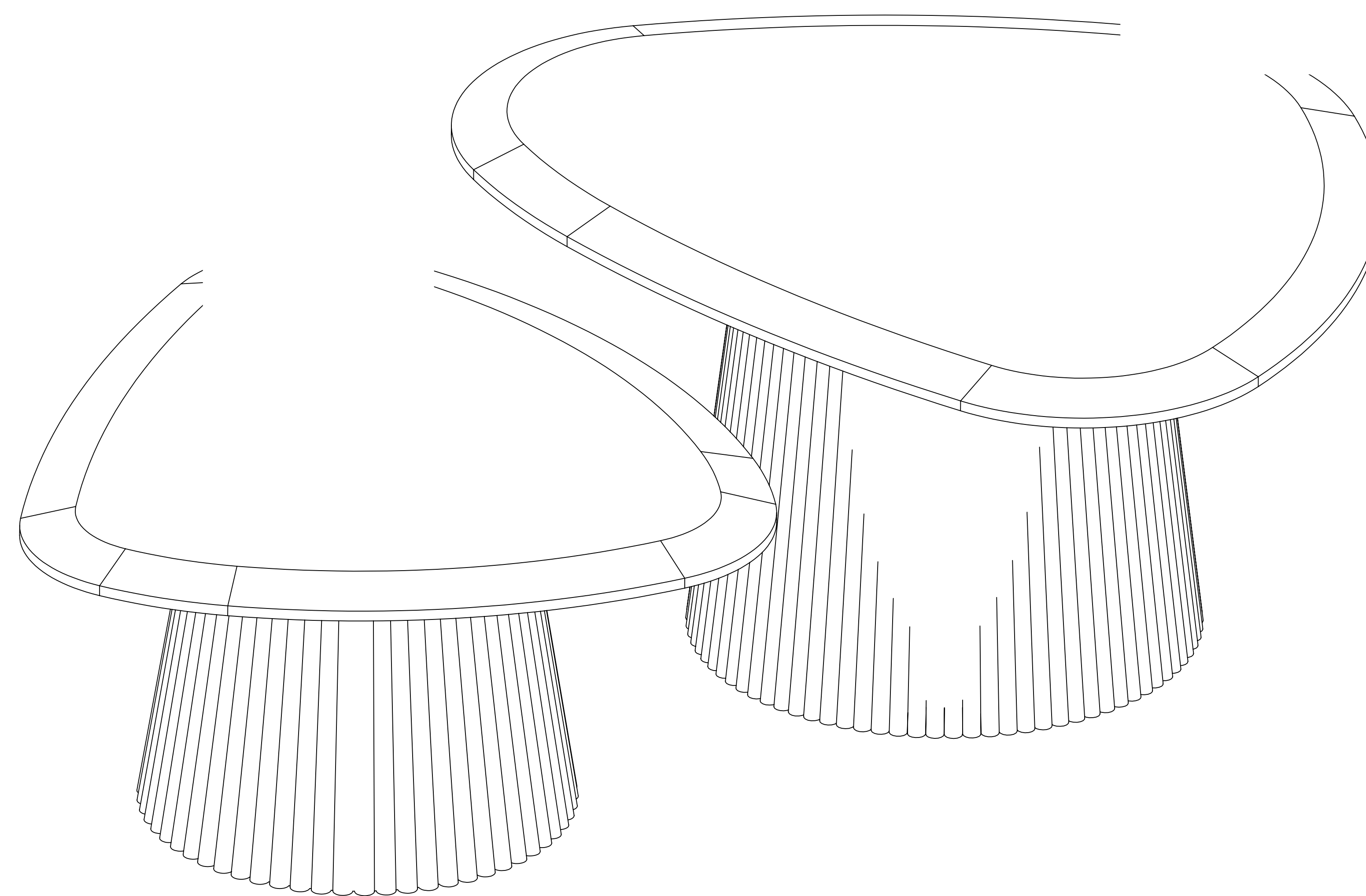



COFFEE TABLE SET/2 WAVE TRIANGULAR TOP

A. PARTS LIST

S.NO.	NAME	QTY
1	TOP - BIG COFFEE TABLE	X1
2	BASE - BIG COFFEE TABLE	X1
3	TOP - SMALL COFFEE TABLE	X1
4	BASE - SMALL COFFEE TABLE	X1

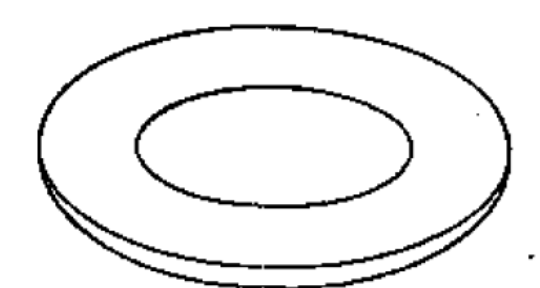
B. HARDWARE LIST

S.NO.	NAME	SIZE	QTY
A		M8X25MM	X4
B		8MM	X4
C		5MM	X1