

Montageanleitung | Instructions de montage Assembly Instructions | Instrucciones de montaje

N616P381024/N616P381025/N616P381026

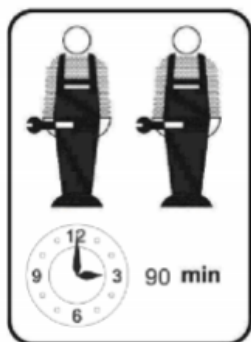
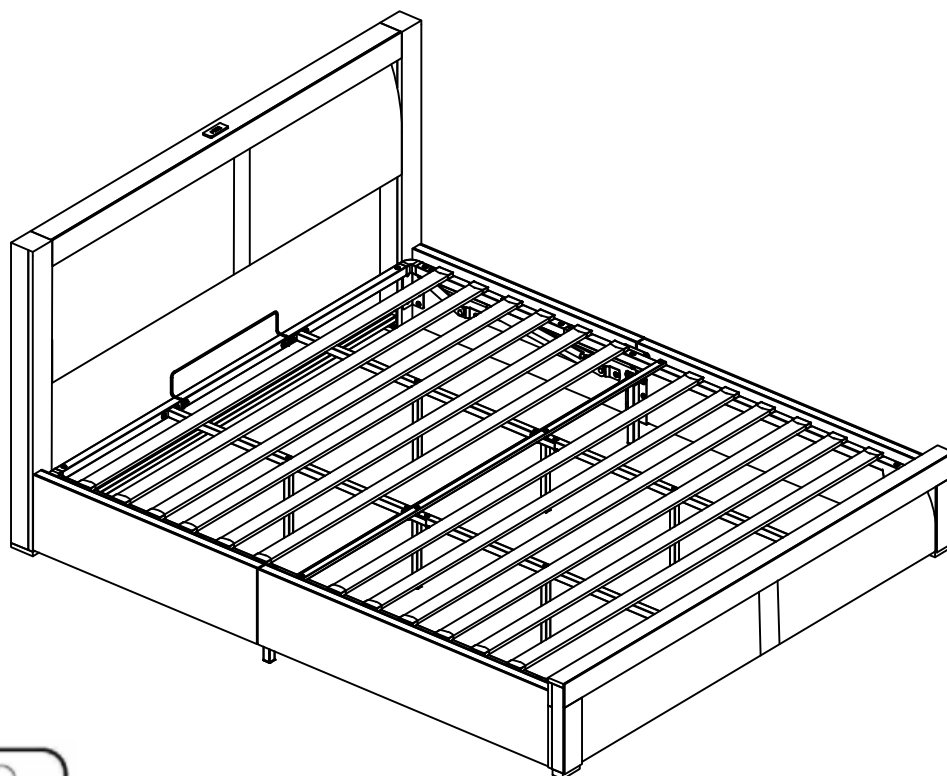

FR

Cet appareil,
ses cordons,
et batterie
se recyclent

À DÉPOSER
EN MAGASIN



OU

À DÉPOSER
EN DÉCHÈTERIE



Points de collecte sur www.quefairedemesdechets.fr
Privilégiez la réparation ou le don de votre appareil !



GB This set comes in 3 boxes. If you do not receive a full set of 3 boxes, please contact our customer service.

DE Dieses Set wird in 3 Schachteln geliefert. Wenn Sie nicht ein komplettes Set von 3 Boxen erhalten, kontaktieren Sie bitte unseren Kundenservice.

FR Ce set est livré en 3 boîtes. Si vous ne recevez pas un jeu complet de 3 boîtes, veuillez contacter notre service clientèle.

English

IMPORTANT FOR GAS LIFT BEDS&MAINTAINANCE

- Please place the mattress on top of the bed frame.
- Please do not pull on the strap handles.
- Please press heavily to release the compressed gas.
- Periodically check all screw & fixings to ensure they are secure.
- When moving your product, carefully lift into place.
- Wipe clean with a slightly damp cloth- please do not use abrasive chemicals or bleach.
- Do NOT allow children to operate the lift mechanism.
- Do NOT allow children near the lift base when operating the mechanism.
- Do NOT stand inside the bed or the internal storage base.
- Do NOT overload the internal storage base.
- DO NOT jump on the product or any of its parts.

Deutsch

WICHTIG FÜR GASLIFT-BETTEN&WARTUNG

- Bitte legen Sie die Matratze oben auf den Bettrahmen.
- Bitte ziehen Sie nicht an den Gurtgriffen.
- Bitte drücken Sie kräftig, um das komprimierte Gas freizusetzen.
- Überprüfen Sie regelmäßig alle Schrauben und Befestigungen, um sicherzustellen, dass sie sicher sind.
- Wenn Sie Ihr Produkt bewegen, heben Sie es vorsichtig an seinen Platz.
- Mit einem leicht feuchten Tuch abwischen - bitte keine scheuernden Chemikalien oder Bleichmittel verwenden.
- Erlauben Sie Kindern NICHT, den Hebemechanismus zu bedienen.
- Lassen Sie Kinder NICHT in die Nähe des Liftsockels, wenn Sie den Mechanismus bedienen.
- Stellen Sie sich NICHT in das Bett oder in die Innenablage.
- Überlasten Sie den internen Liftsockel NICHT.
- Springen Sie NICHT auf das Produkt oder eines seiner Teile.

Français

IMPORTANT POUR LES LITS À RELEVAGE DE GAZ&MAINTENANCE

- Veuillez placer le matelas sur le dessus du cadre de lit.
- Ne tirez pas sur les poignées de la sangle.
- Appuyez fortement pour libérer le gaz comprimé.
- Vérifiez régulièrement que toutes les vis et fixations sont bien en place.
- Lorsque vous déplacez votre produit, soulevez-le avec précaution pour le mettre en place.
- Nettoyez avec un chiffon légèrement humide - n'utilisez pas de produits chimiques abrasifs ou d'eau de Javel.
- Ne laissez pas les enfants utiliser le mécanisme de levage.
- Ne laissez pas les enfants s'approcher de la base de levage lorsqu'ils actionnent le mécanisme.
- Ne vous tenez PAS à l'intérieur du lit ou de la base de stockage interne.
- Ne surchargez pas la base de stockage interne.
- Ne pas sauter sur le produit ou l'une de ses parties.

Italiano

IMPORTANTE PER I LETTI CON SOLLEVAMENTO A GAS E LA MANUTENZIONE

- Posizionare il materasso sopra la struttura del letto.
- Non tirare le maniglie della cinghia.
- Premere con forza per rilasciare il gas compresso.
- Controllare periodicamente tutte le viti e i fissaggi per assicurarsi che siano saldi.
- Quando si sposta il prodotto, sollevarlo con cautela.
- Pulire con un panno leggermente umido, senza usare prodotti chimici abrasivi o candeggina.
- NON permettere ai bambini di azionare il meccanismo di sollevamento.
- NON permettere ai bambini di avvicinarsi alla base di sollevamento quando si aziona il meccanismo.
- NON sostare all'interno del letto o della base di contenimento interna.
- NON sovraccaricare la base di contenimento interna.
- NON saltare sul prodotto o sulle sue parti.

Español

IMPORTANTE PARA LAS CAMAS ELEVADORAS DE GAS&MANTENIMIENTO

- Coloque el colchón sobre el somier.
- No tire de las asas de la correa.
- Presione con fuerza para liberar el gas comprimido.
- Compruebe periódicamente que todos los tornillos y fijaciones estén bien sujetos.
- Al mover el producto, levántelo con cuidado para colocarlo en su sitio.
- Limpie con un paño ligeramente humedecido; no utilice productos químicos abrasivos ni lejía.
- NO permita que los niños accionen el mecanismo de elevación.
- NO permita que los niños se acerquen a la base elevadora cuando accionen el mecanismo.
- NO se ponga de pie dentro de la cama o de la base de almacenamiento interna.
- NO sobrecargue el somier.
- NO salte sobre el producto ni sobre ninguna de sus piezas.

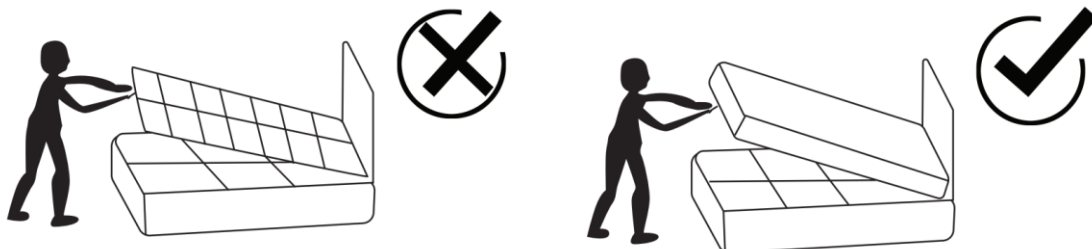

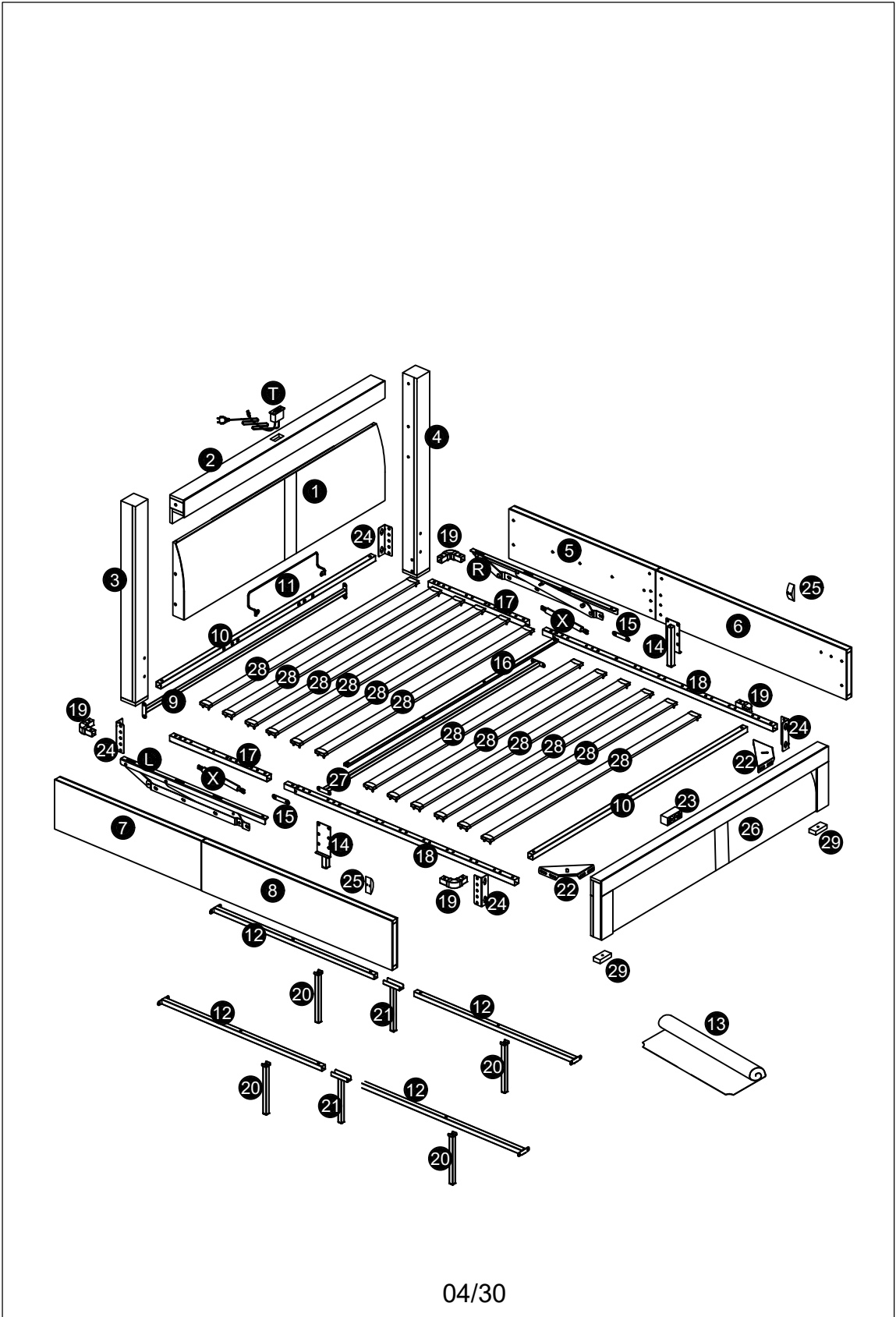



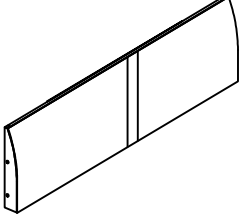
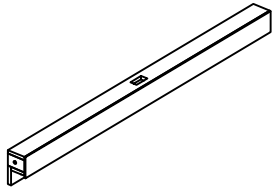
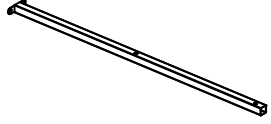
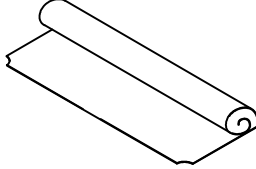
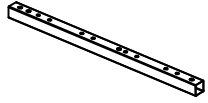
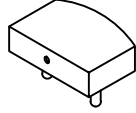

N616P381024

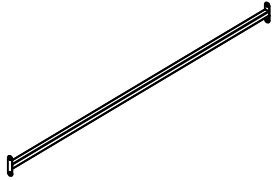
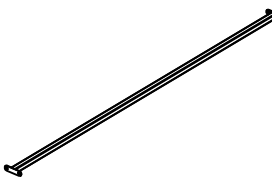
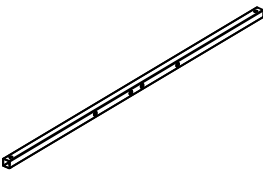
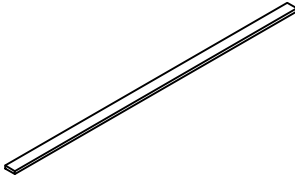
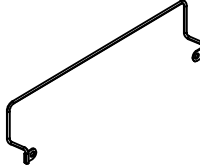
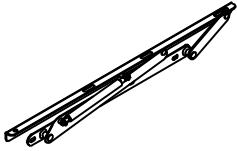
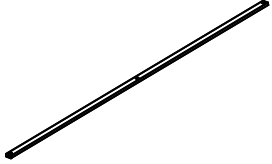
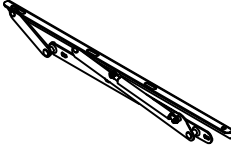
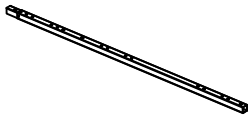
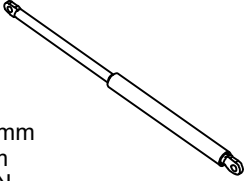
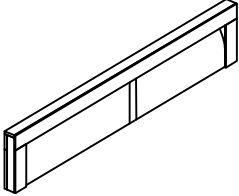
1		X1			
2		X1			
12		X4			
13		X1			
17		X2			
P		X24			

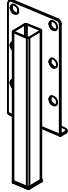

N616P381025

<p>9</p>		<p>X1</p>	<p>27</p>		<p>X1</p>
<p>10</p>		<p>X2</p>	<p>28</p>		<p>X12</p>
<p>11</p>		<p>X1</p>	<p>L</p>		<p>X1</p>
<p>16</p>		<p>X1</p>	<p>R</p>		<p>X1</p>
<p>18</p>		<p>X2</p>	<p>X</p>	<p>400mm 9mm 750N</p> 	<p>X2</p>
<p>26</p>		<p>X1</p>			

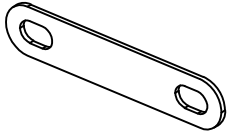
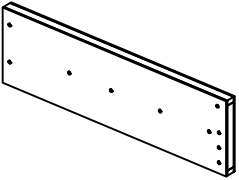
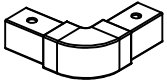
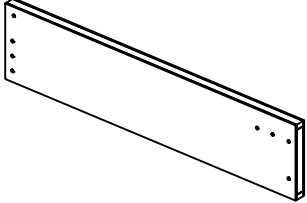
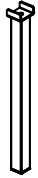
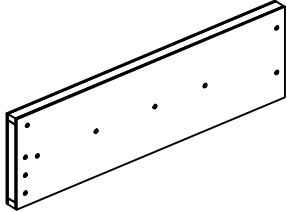
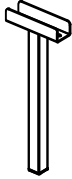
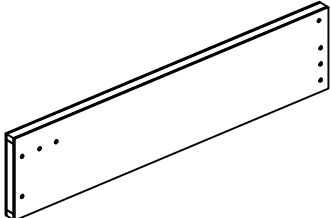
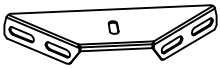
N616P381026



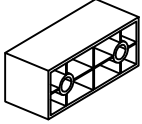
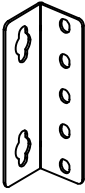

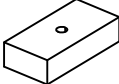





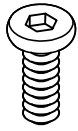
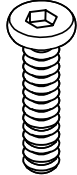



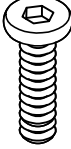

<p>3</p>		<p>X1</p>	<p>14</p>		<p>X2</p>
<p>4</p>		<p>X1</p>	<p>15</p>		<p>X2</p>
<p>5</p>		<p>X1</p>	<p>19</p>		<p>X4</p>
<p>6</p>		<p>X1</p>	<p>20</p>		<p>X4</p>
<p>7</p>		<p>X1</p>	<p>21</p>		<p>X2</p>
<p>8</p>		<p>X1</p>	<p>22</p>		<p>X2</p>

N616P381026

23		X1			
24		X4			
25		X2			
29		X2			

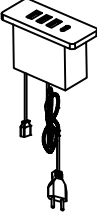

Hardware List-Hardware-Liste-Liste du matériel

N616P381026

A	 M8X30	X8+1	G	 M8X50	X10+2	N	 Long	X1
B	 M8X20	X56+2	H	 M8	X1	O	 Silent Sticker	X4
C	 ST4X25	X4+1	I	 Velcro fastener	X9	P	 X24	X24
D	 M8X40	X10+2	J	 M8	X1	Q	 X1	X1
E	 M8	X12+2	K	 Remote Control	X1	S	 X1	X1
F	 ST3X12	X2+1	M	 Short	X1	T	 X1	X1

Hardware List-Hardware-Liste-Liste du matériel

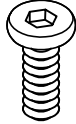
N616P381026

	 M8X35	X6+1
	 M8X15	X14+2

1

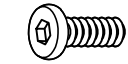

M8X35
UX4pcs

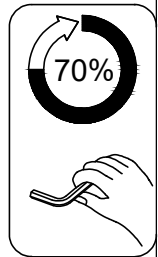
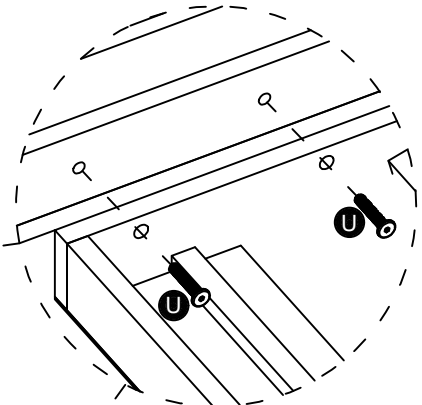
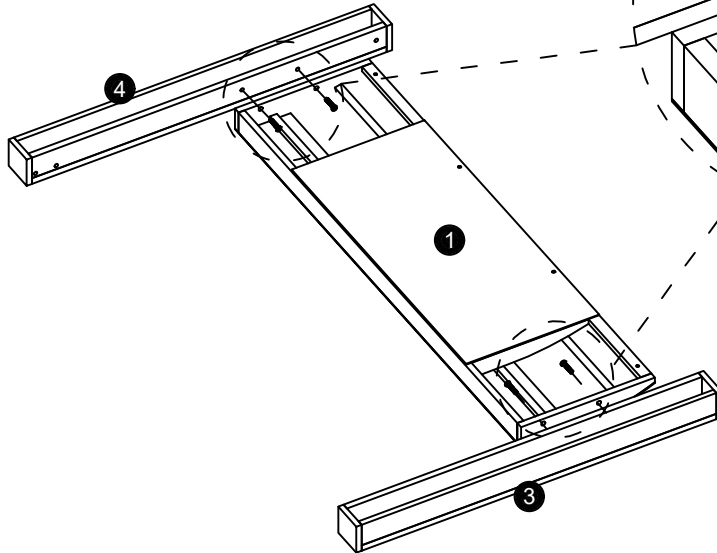

2

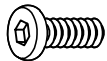

M8X30
AX4pcs



M8X35
UX2pcs

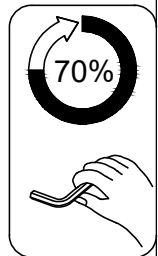
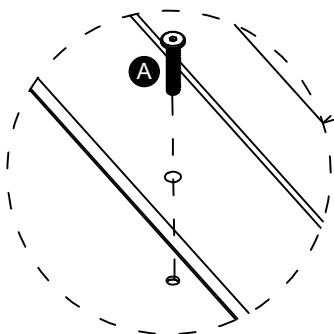
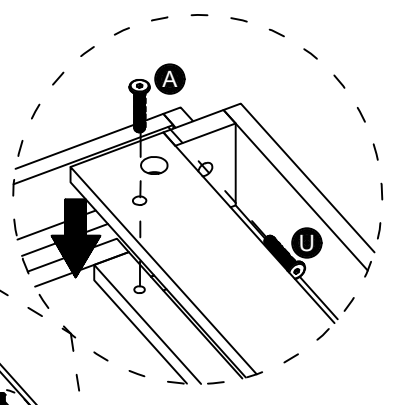
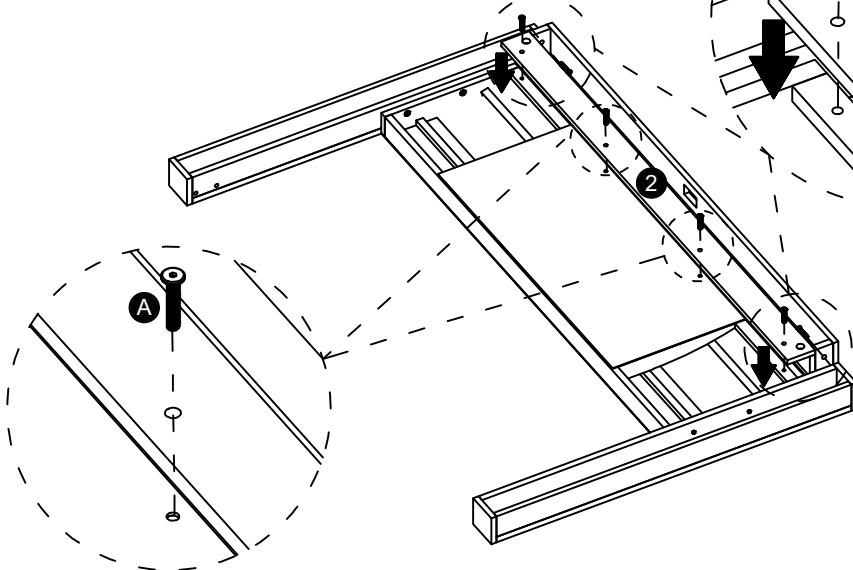

3

M8X20
BX4pcs

Tighten all screws to 100%

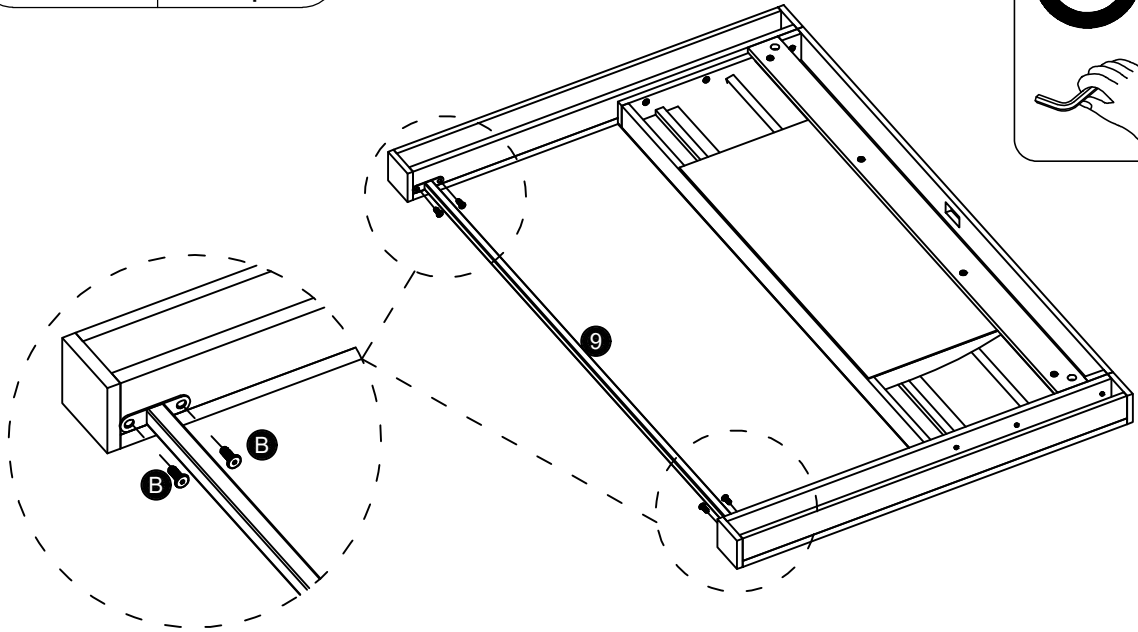
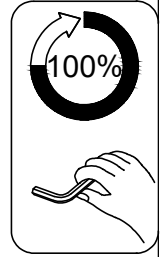

4

M8X20
BX4pcs

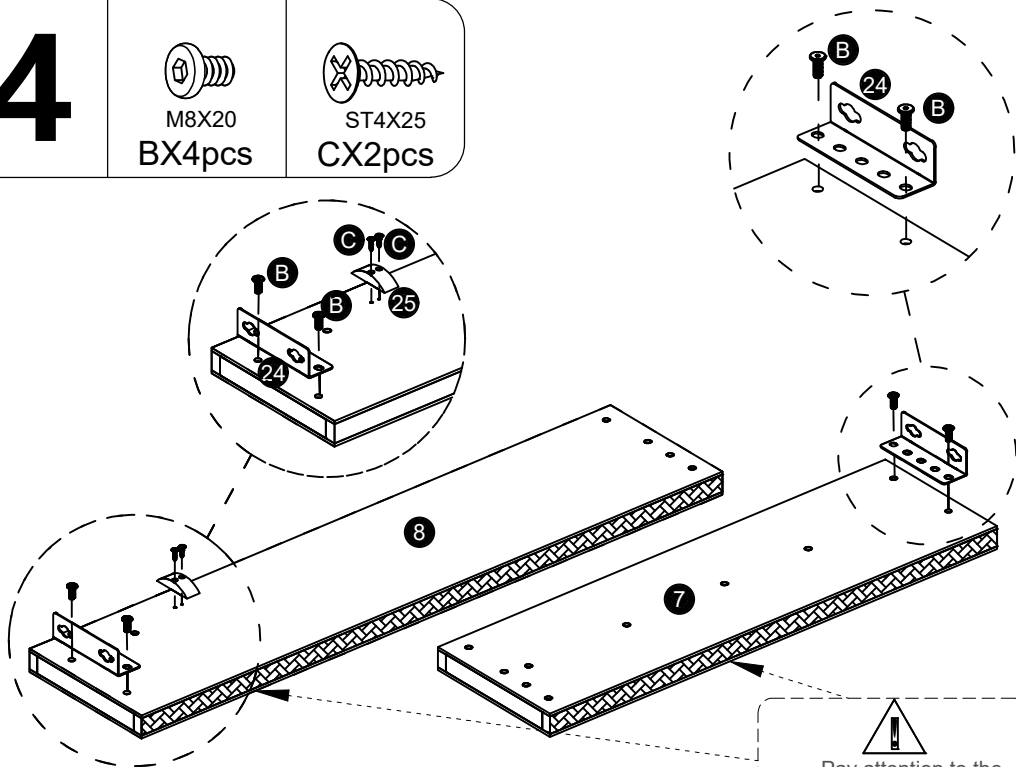

ST4X25
CX2pcs



Pay attention to the
Velcro on this side

5

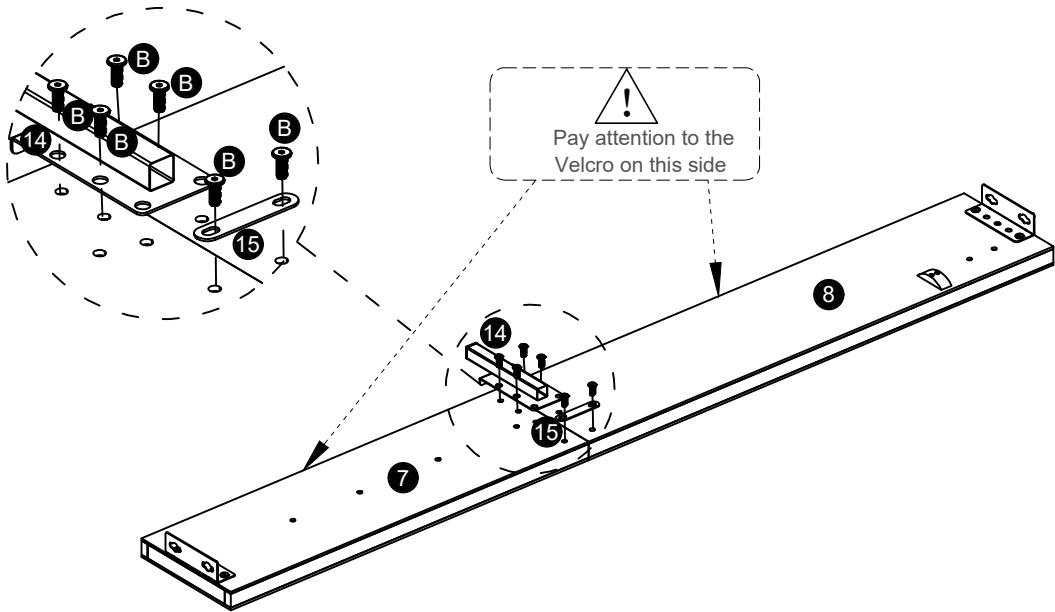
M8X20
BX6pcs



6

M8X20
BX4pcs

ST4X25
CX2pcs

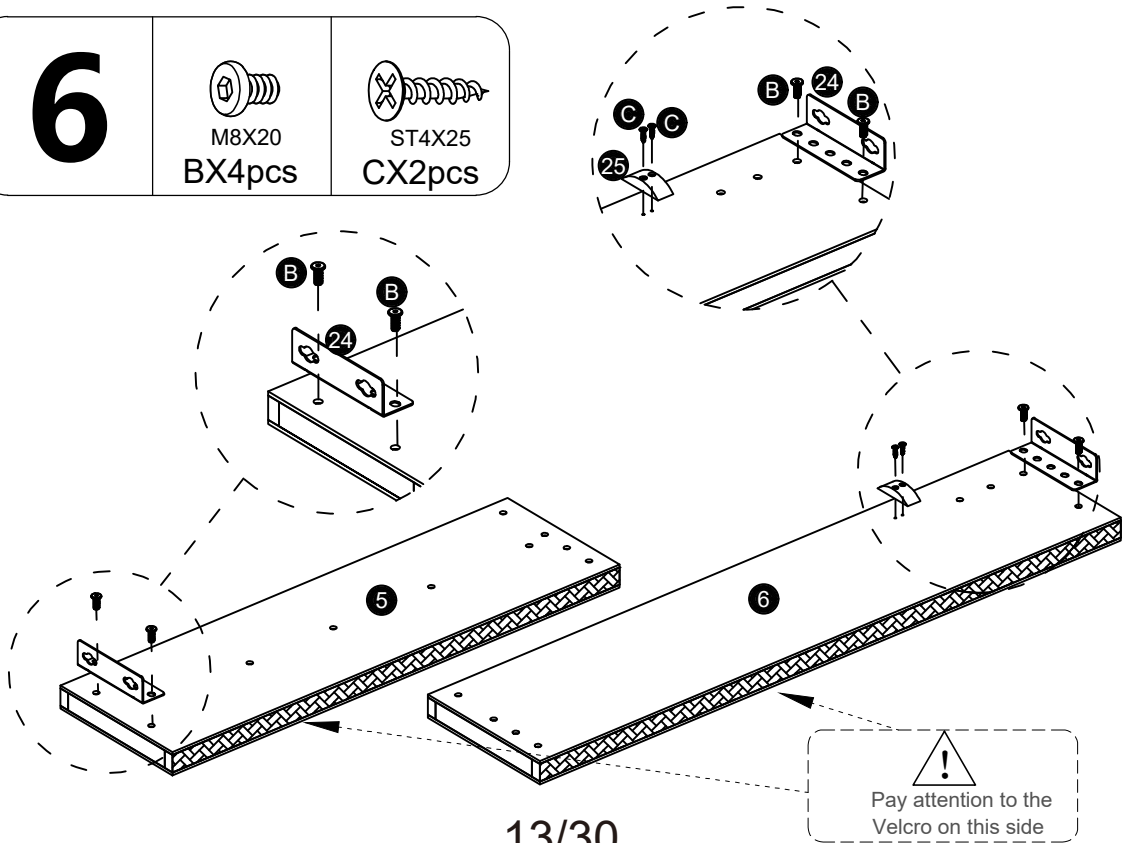

7

M8X20
BX6pcs

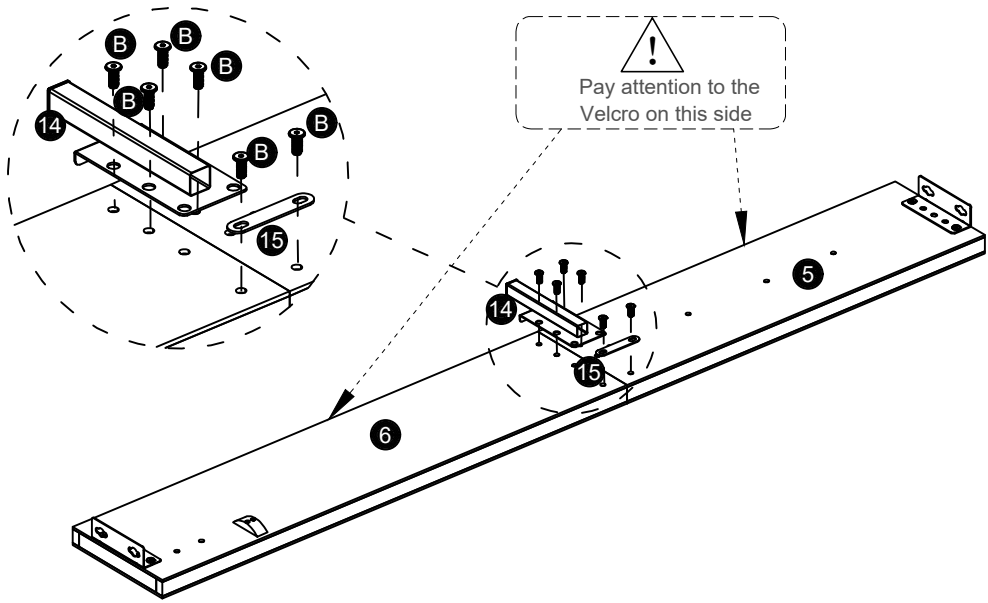

8

M8X20
BX4pcs

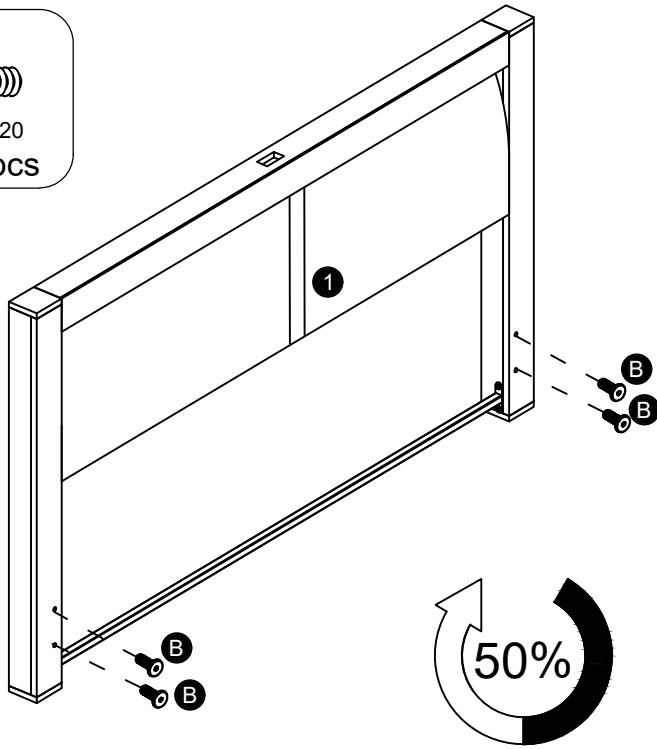

9

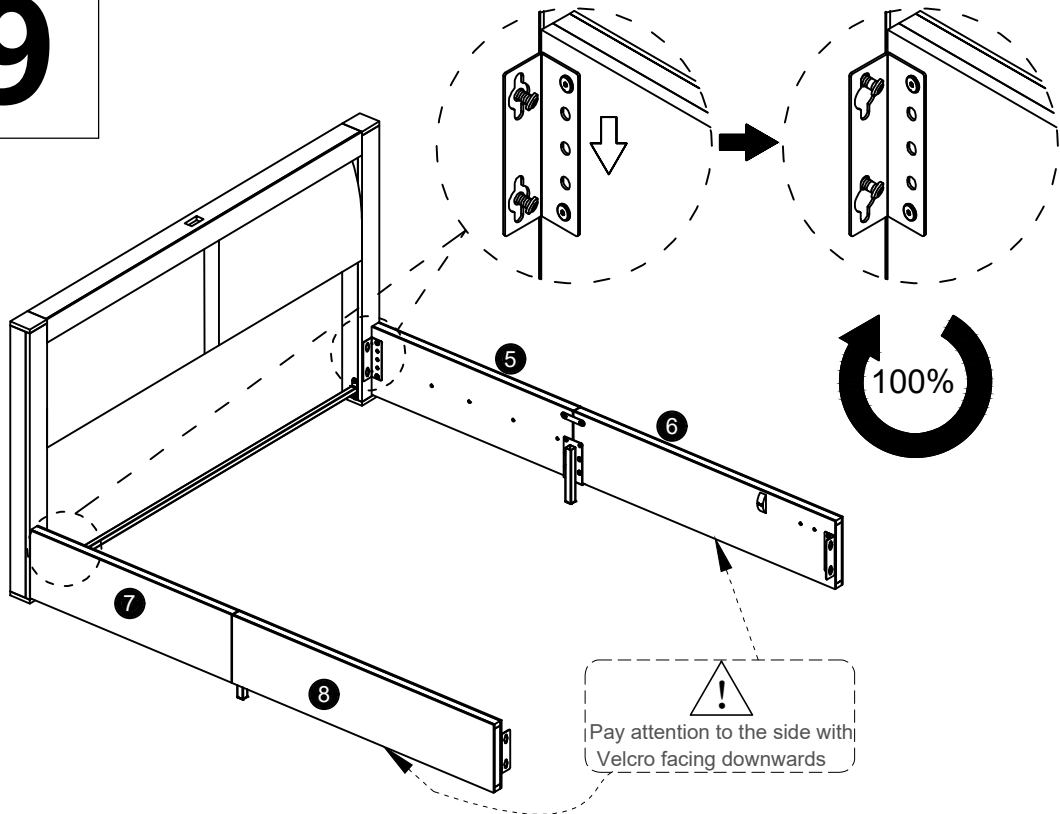

10

M8X20
BX4pcs

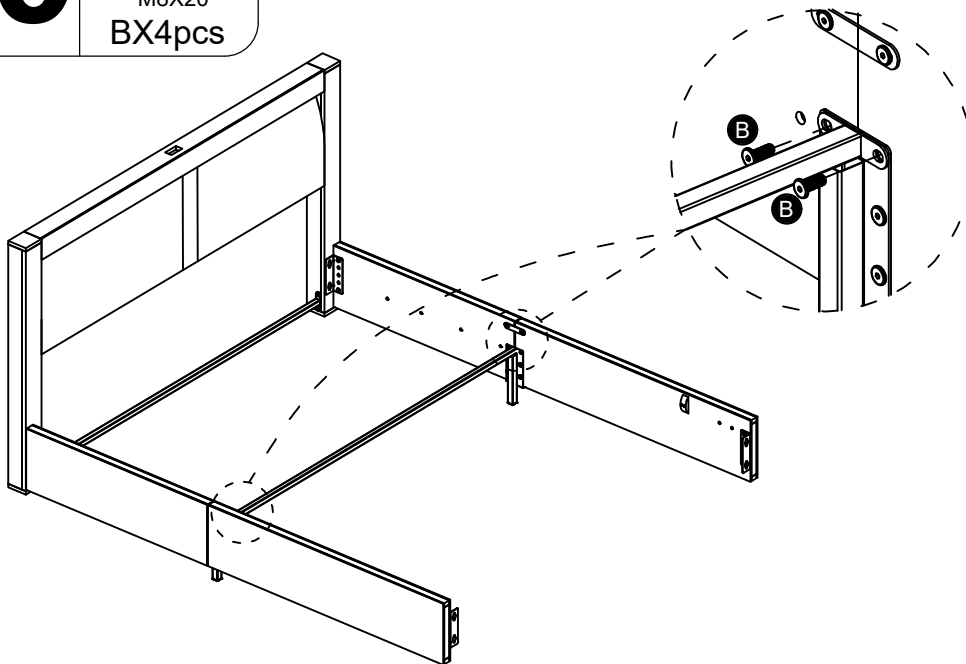

11

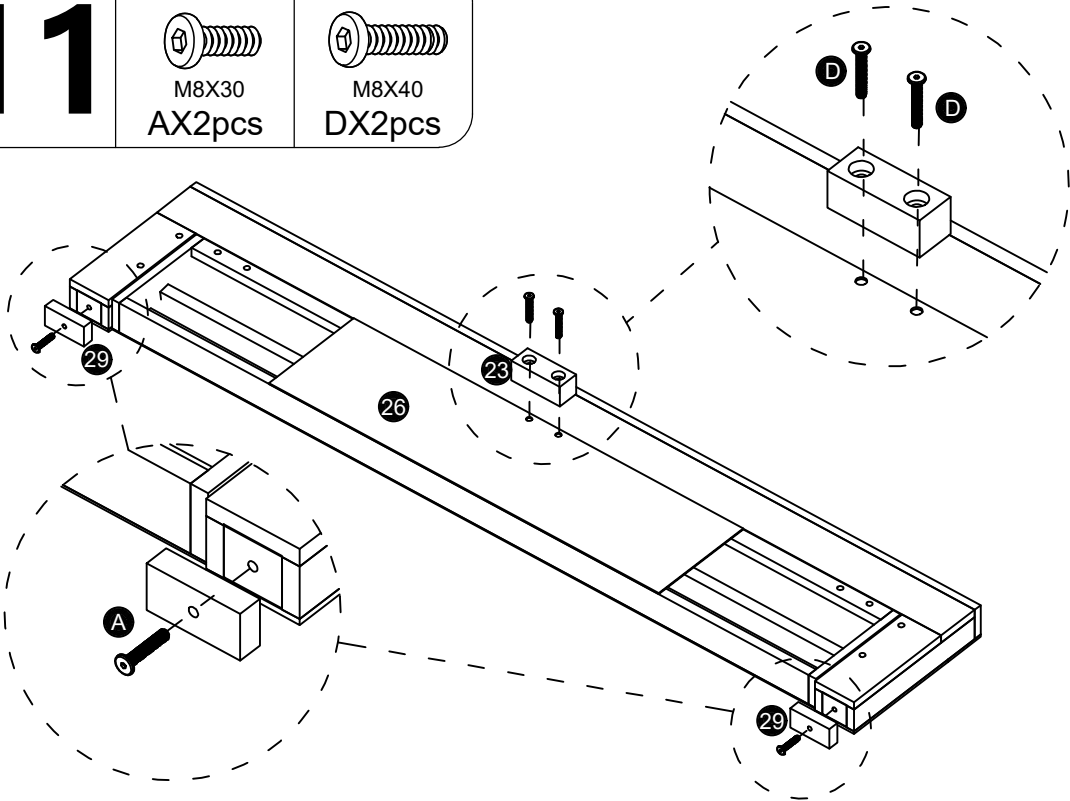

M8X30
AX2pcs

M8X40
DX2pcs



12

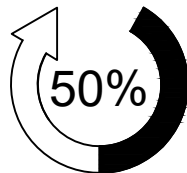
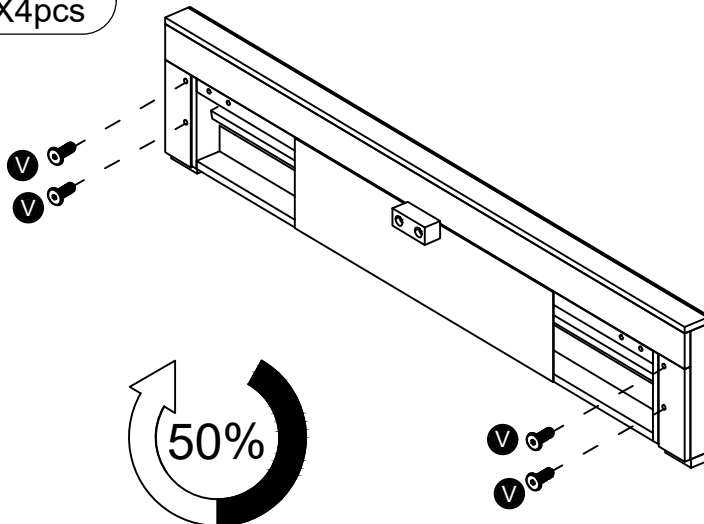

M8X15
VX4pcs

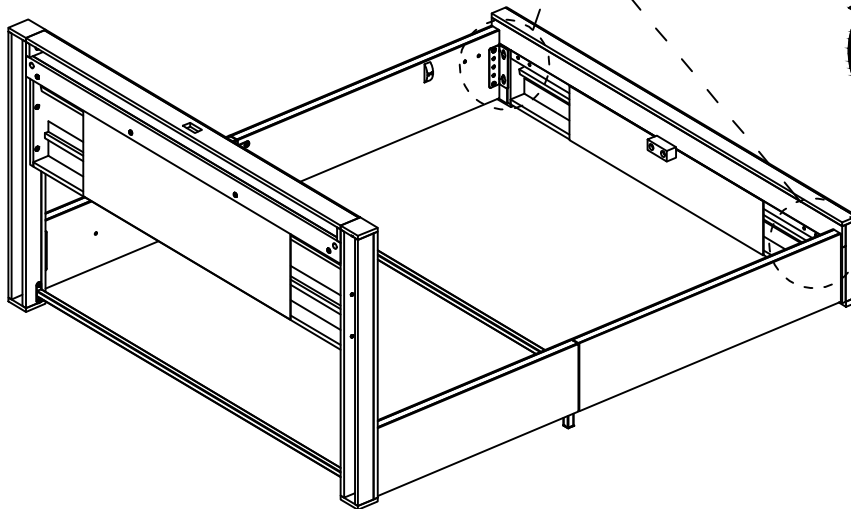
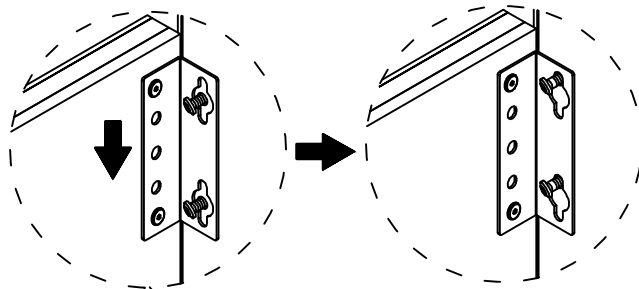

13

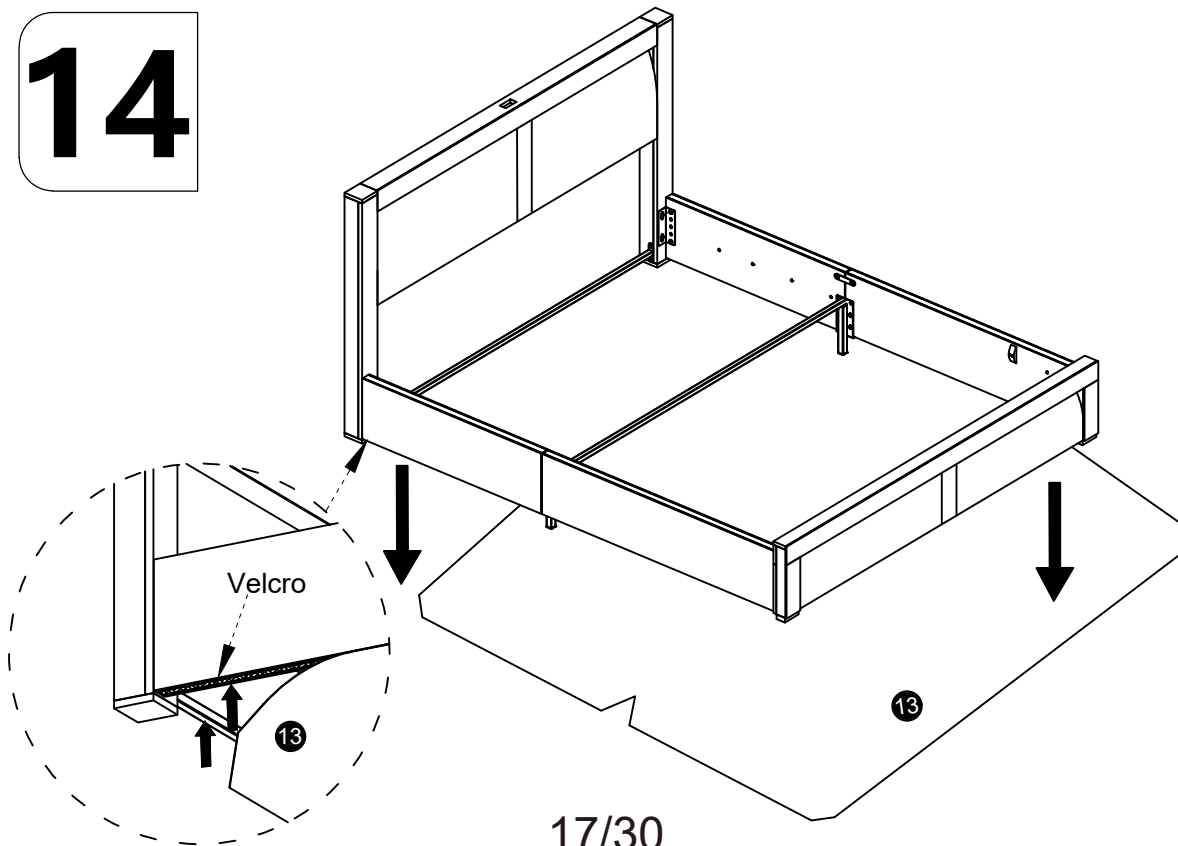

14



15

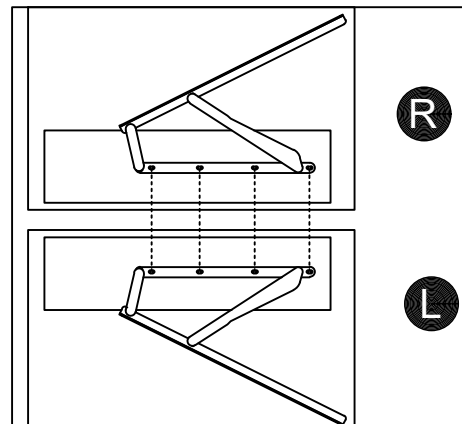
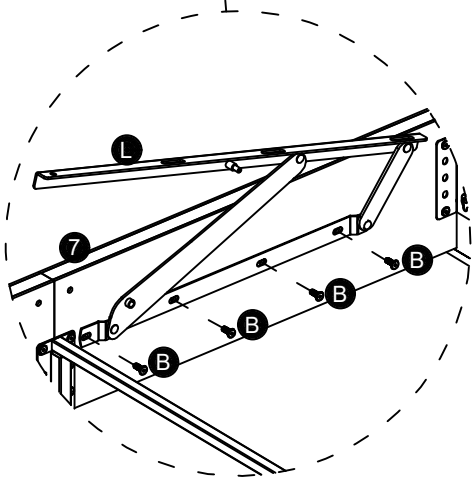
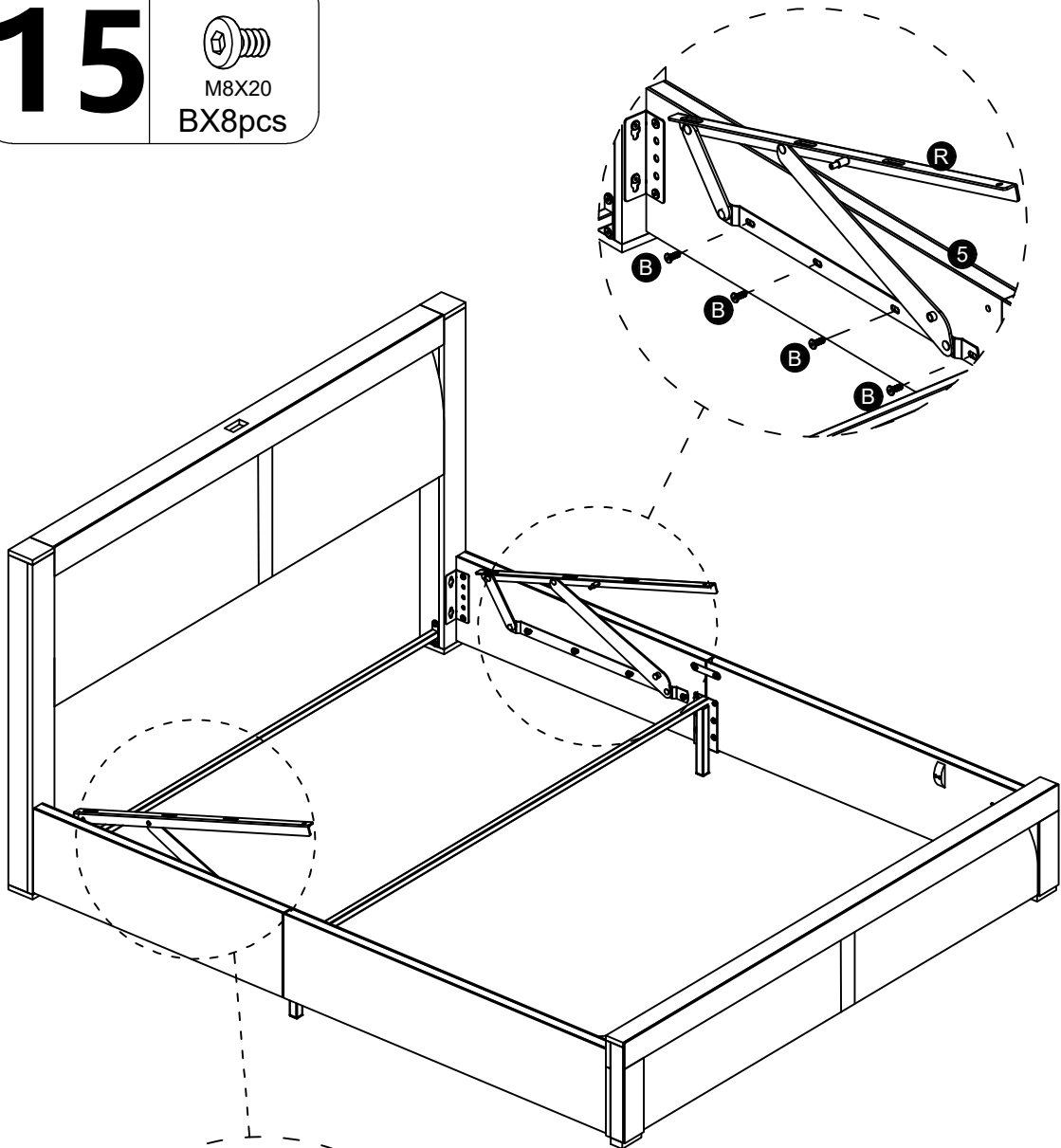

M8X20
BX8pcs



16

M8
EX4pcs

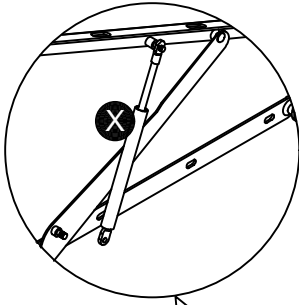
NO.1



NO.2

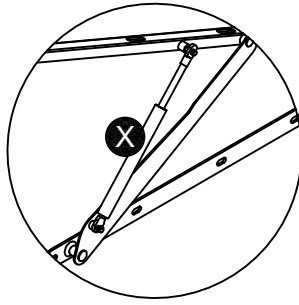

NO.3

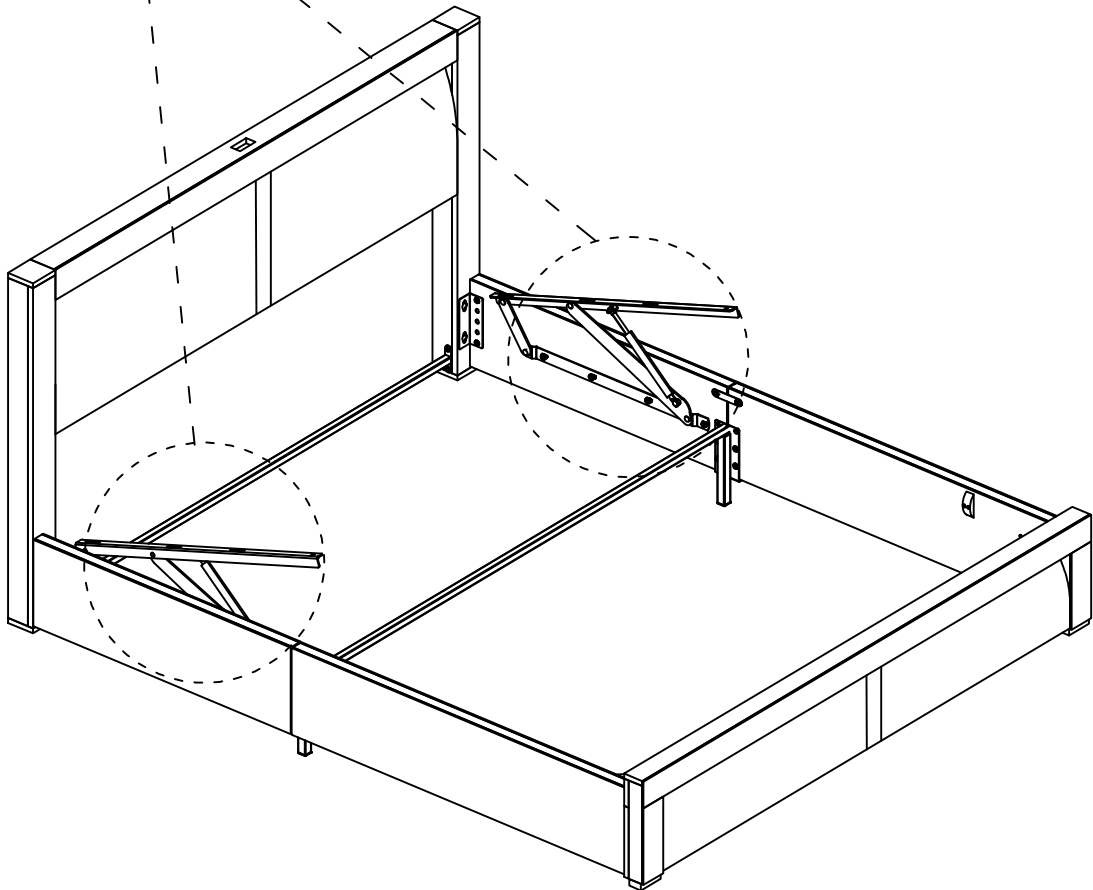
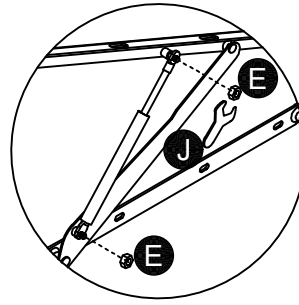

17

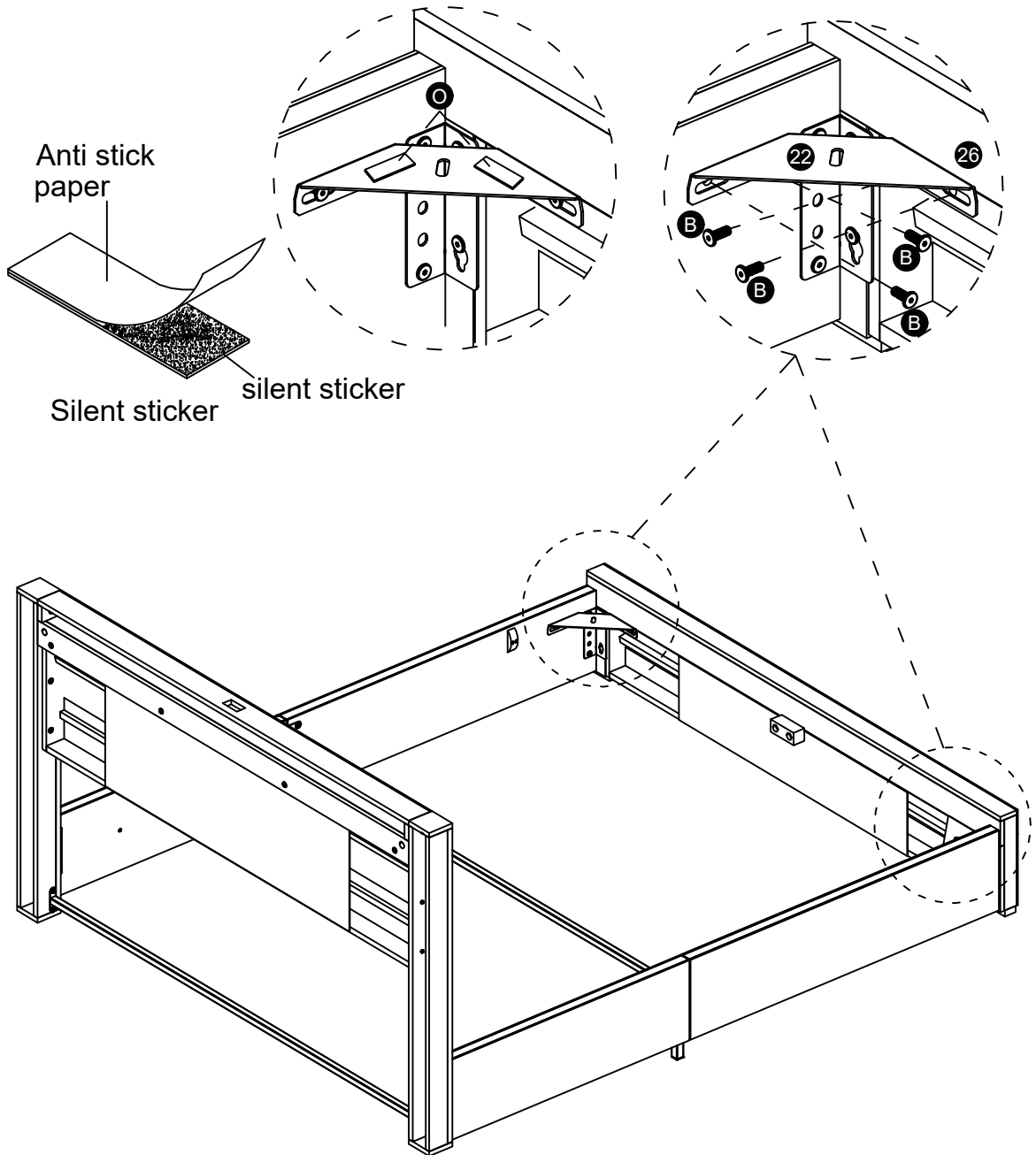

M8X20
BX8pcs

OX4pcs

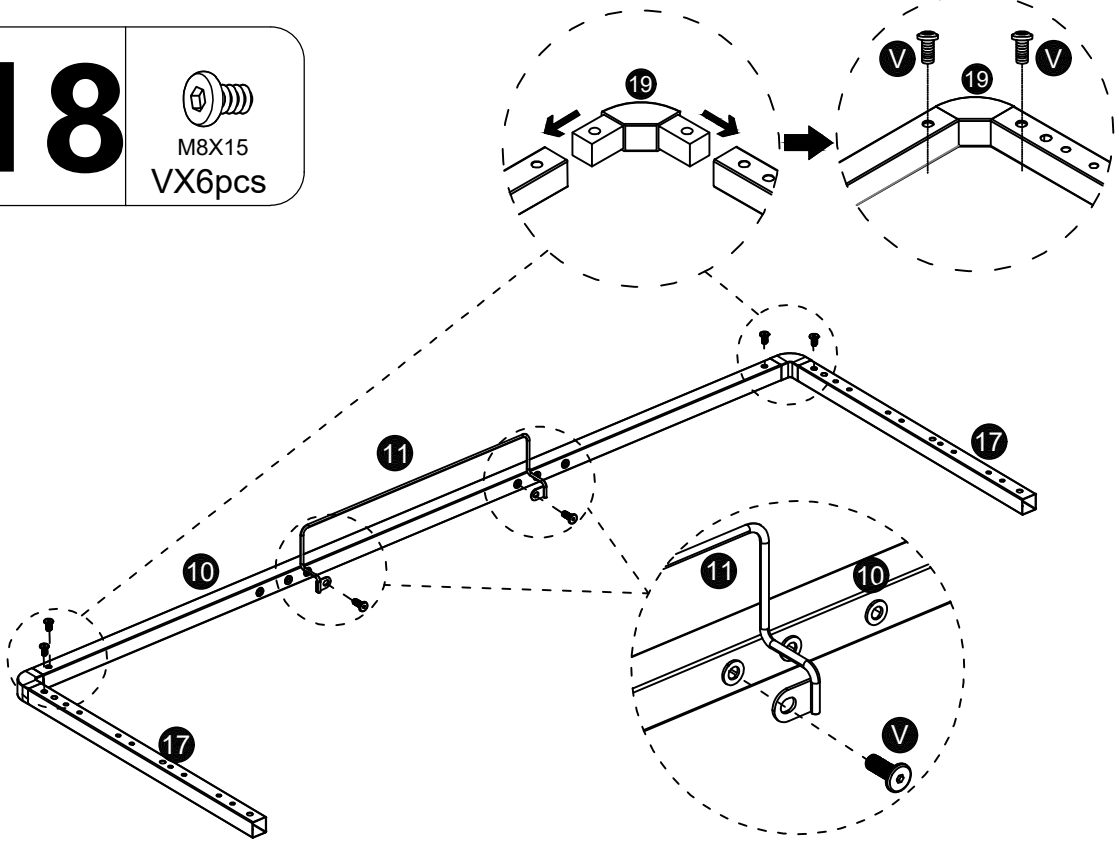

18

M8X15
VX6pcs



19

M8X15
VX4pcs

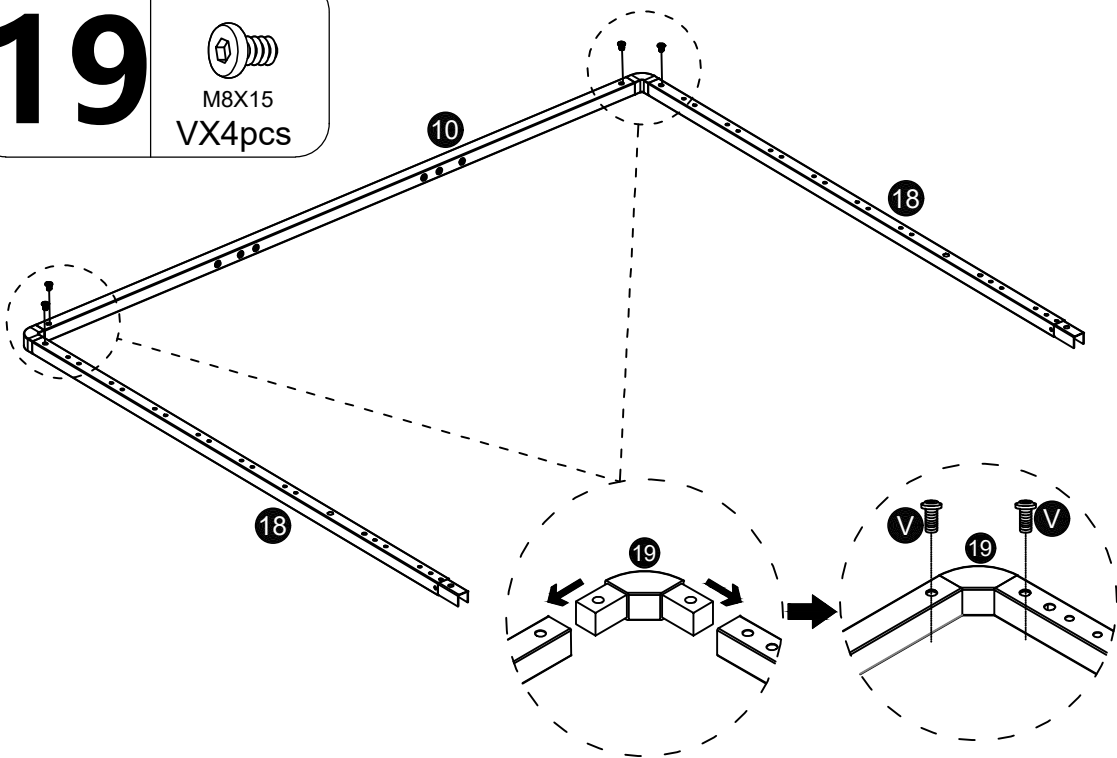

20

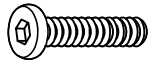

M8X50
GX4pcs



M8
EX4pcs

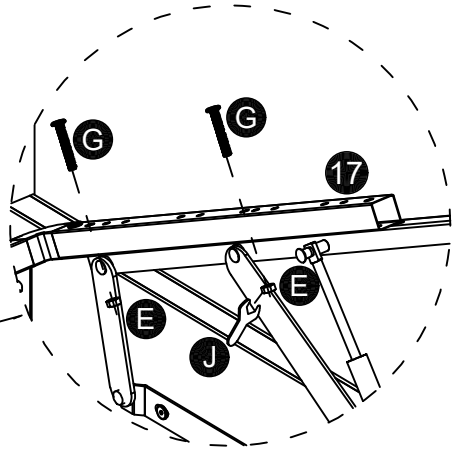
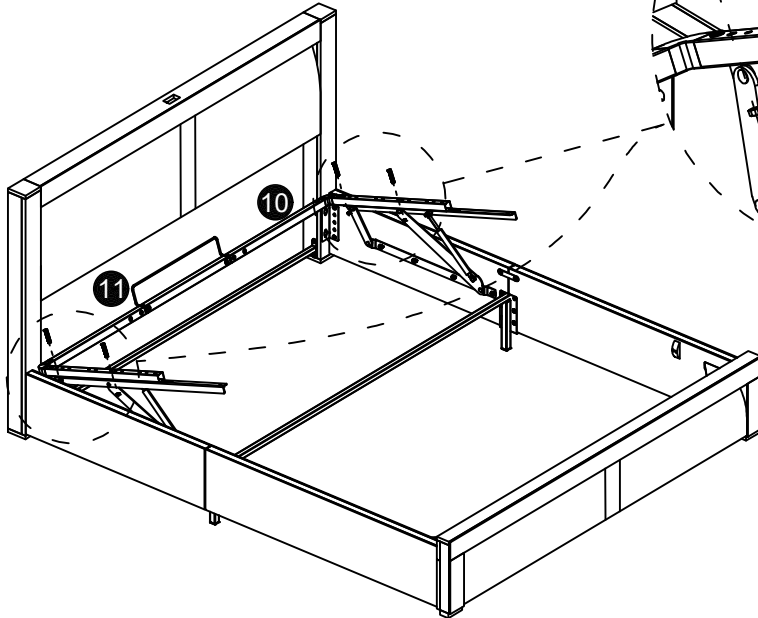

21

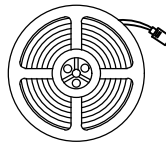

N Light strip
1PC Long



Pull out

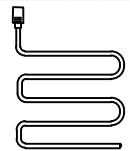

Light strip

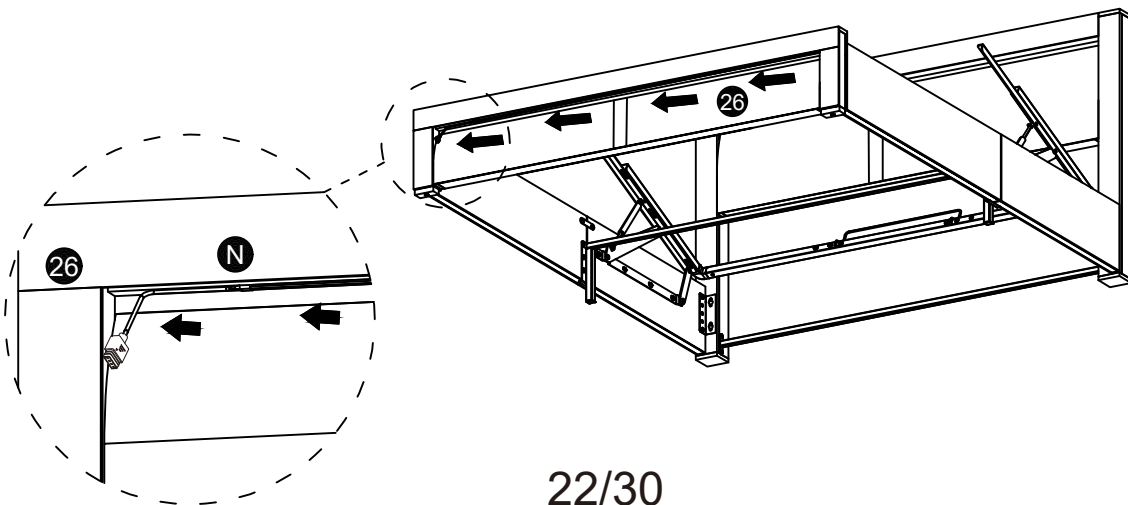

22



1X3pcs

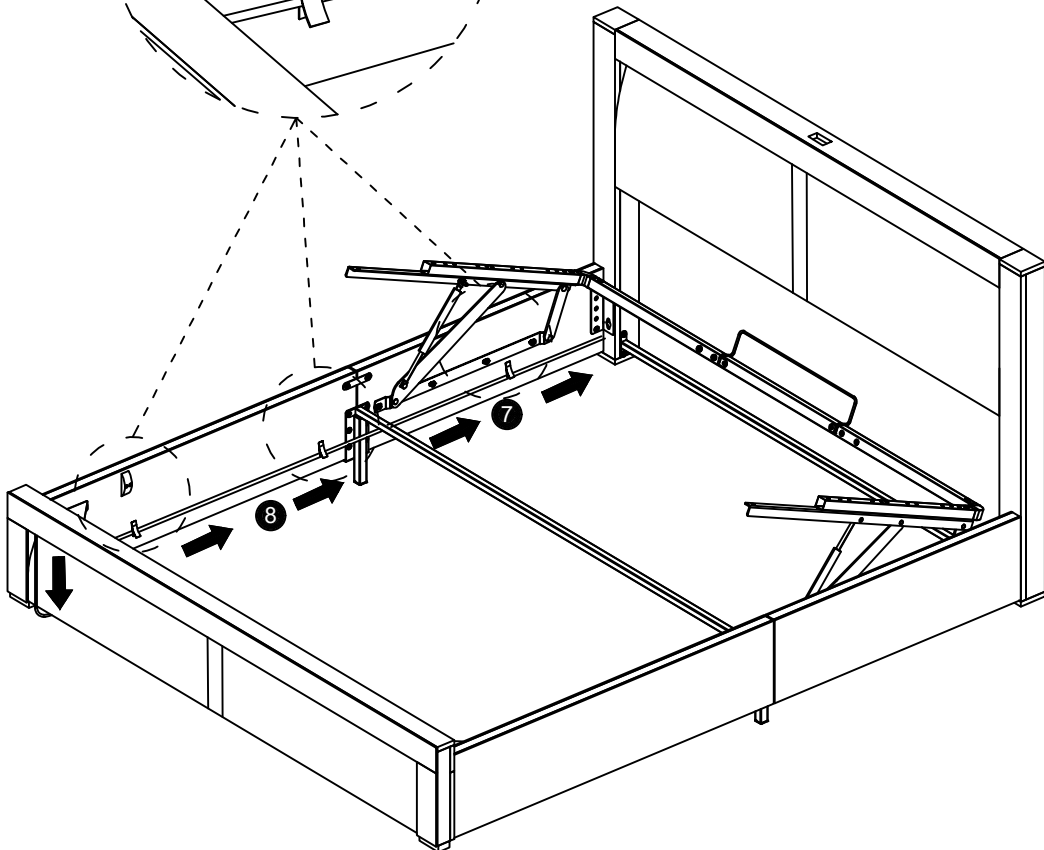
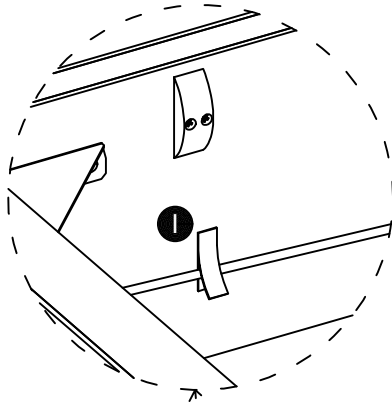
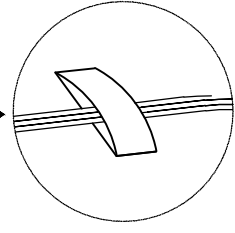
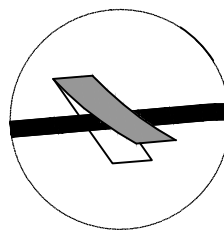
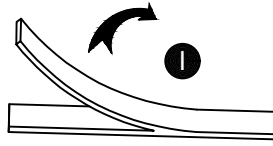

23

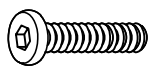

M8X50
GX4pcs



M8
EX4pcs

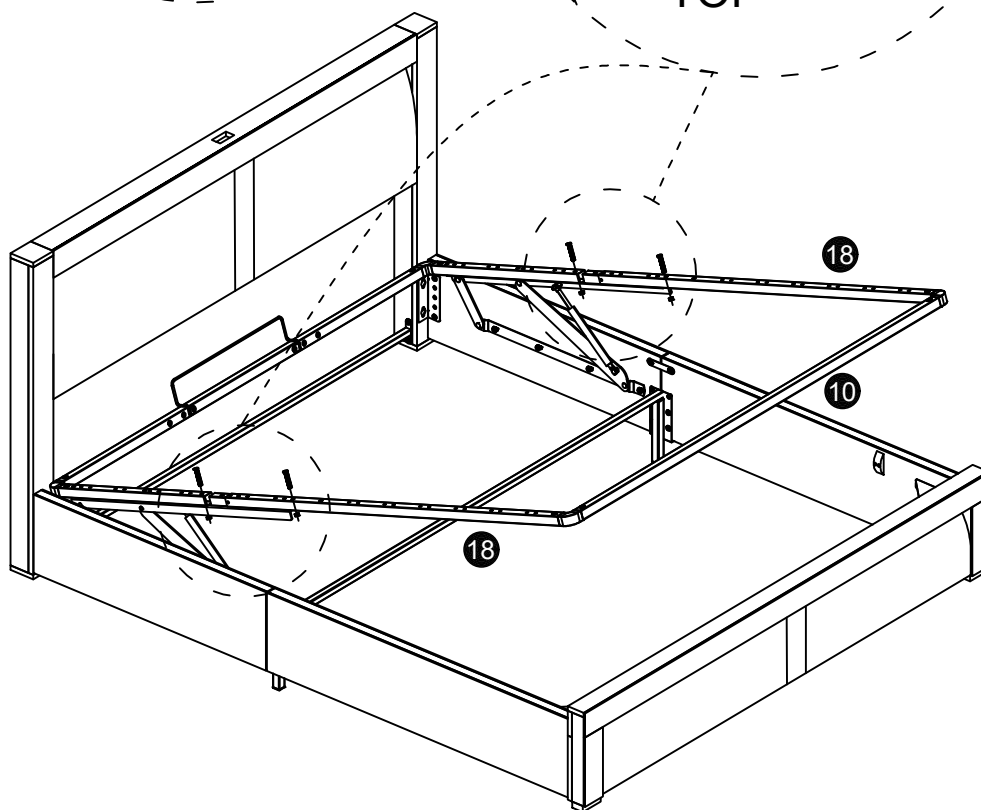
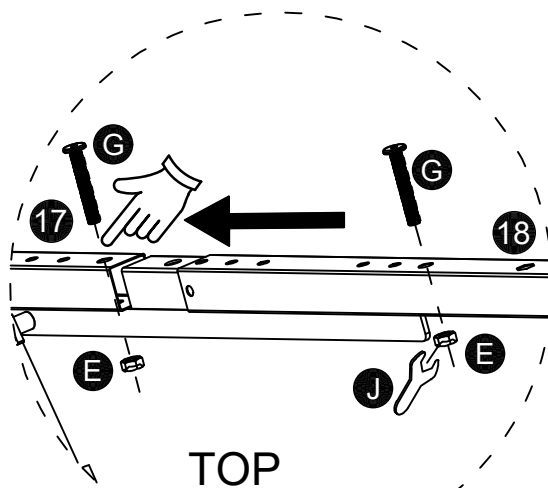
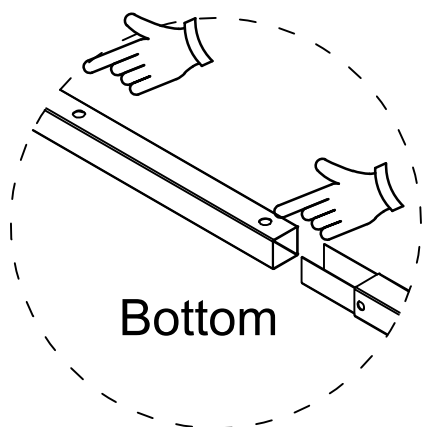

24

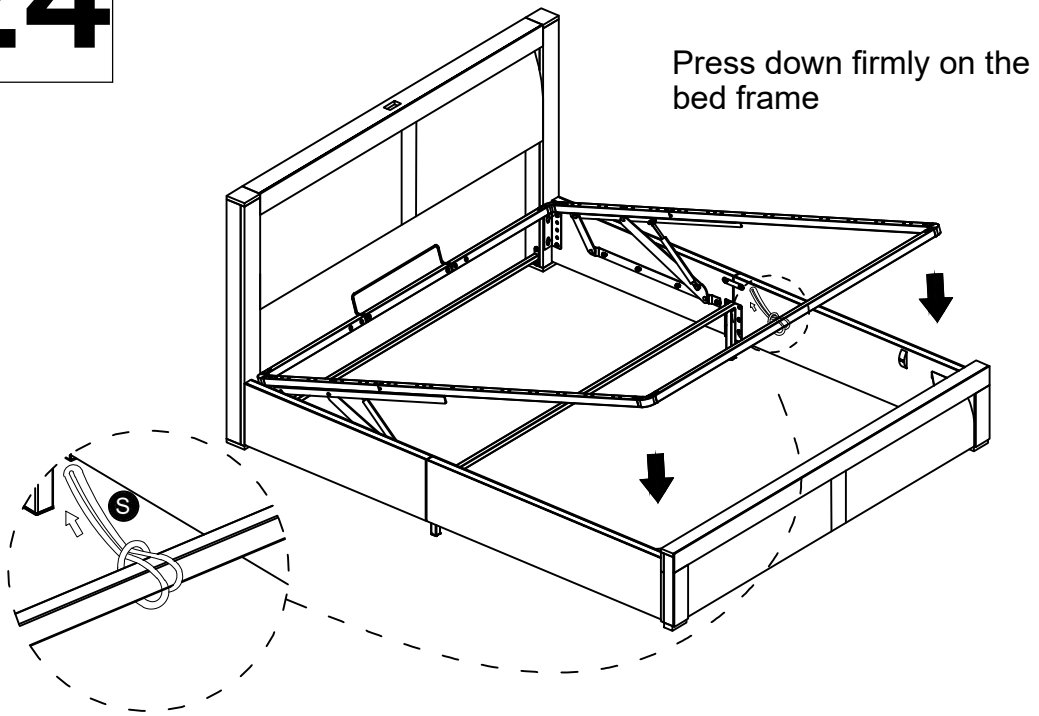

25

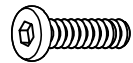

M8X40
DX8pcs

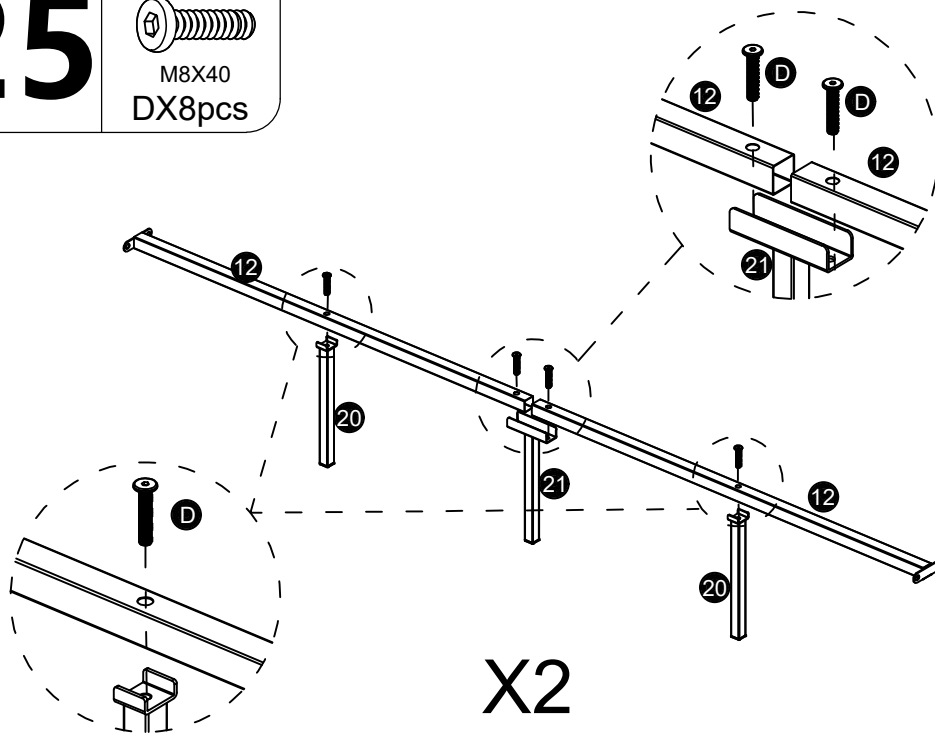

26

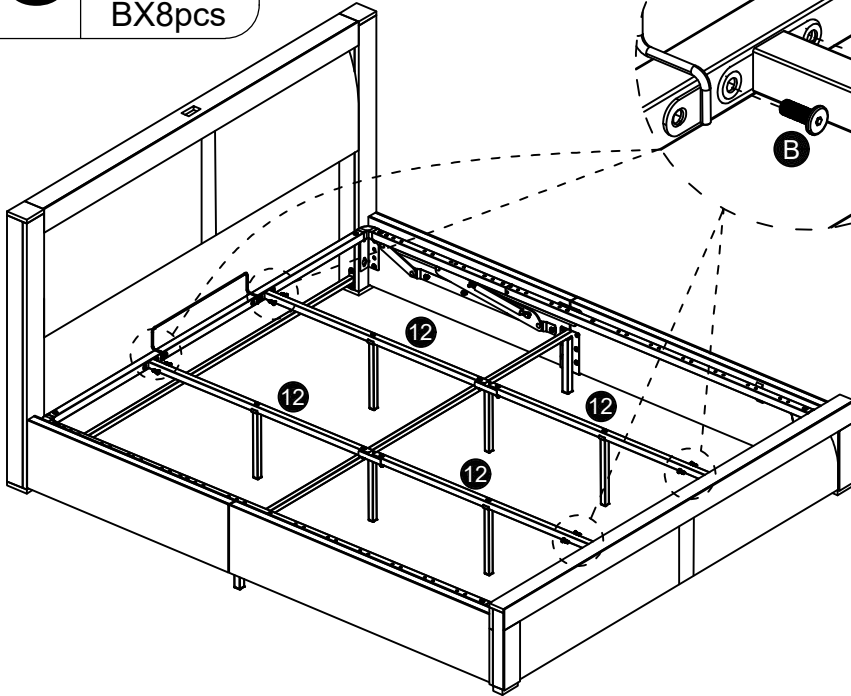

M8X20
BX8pcs



27

M8X30
AX2pcs

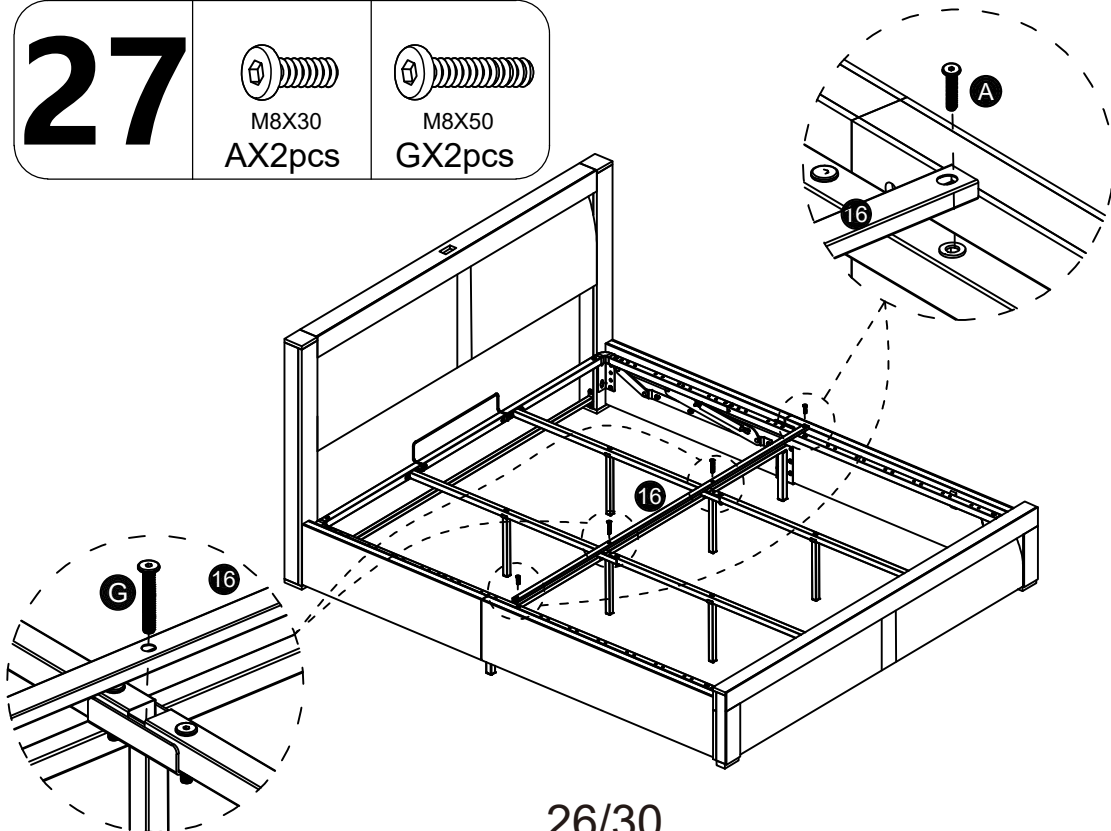
M8X50
GX2pcs



26/30

28



PX24pcs

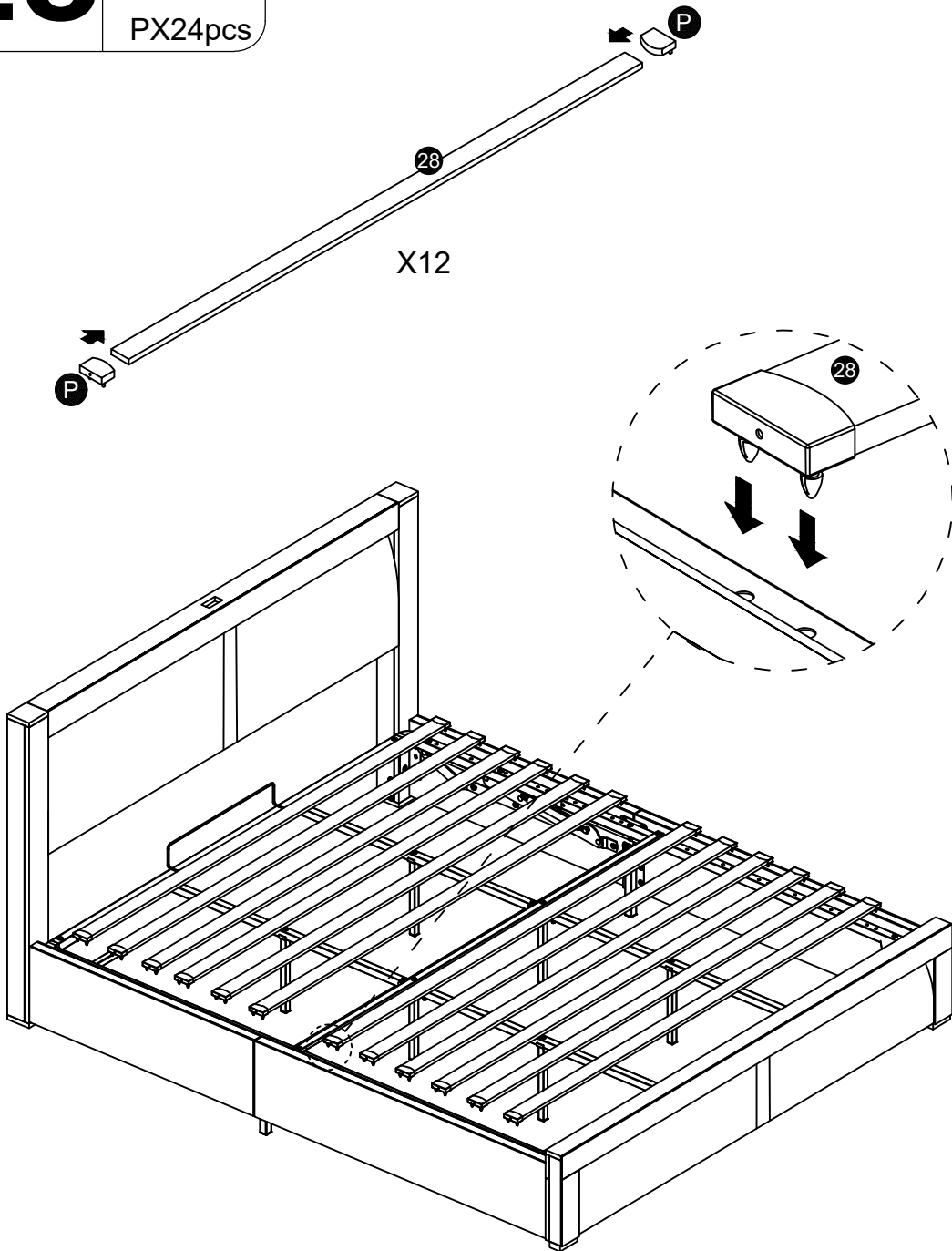



29

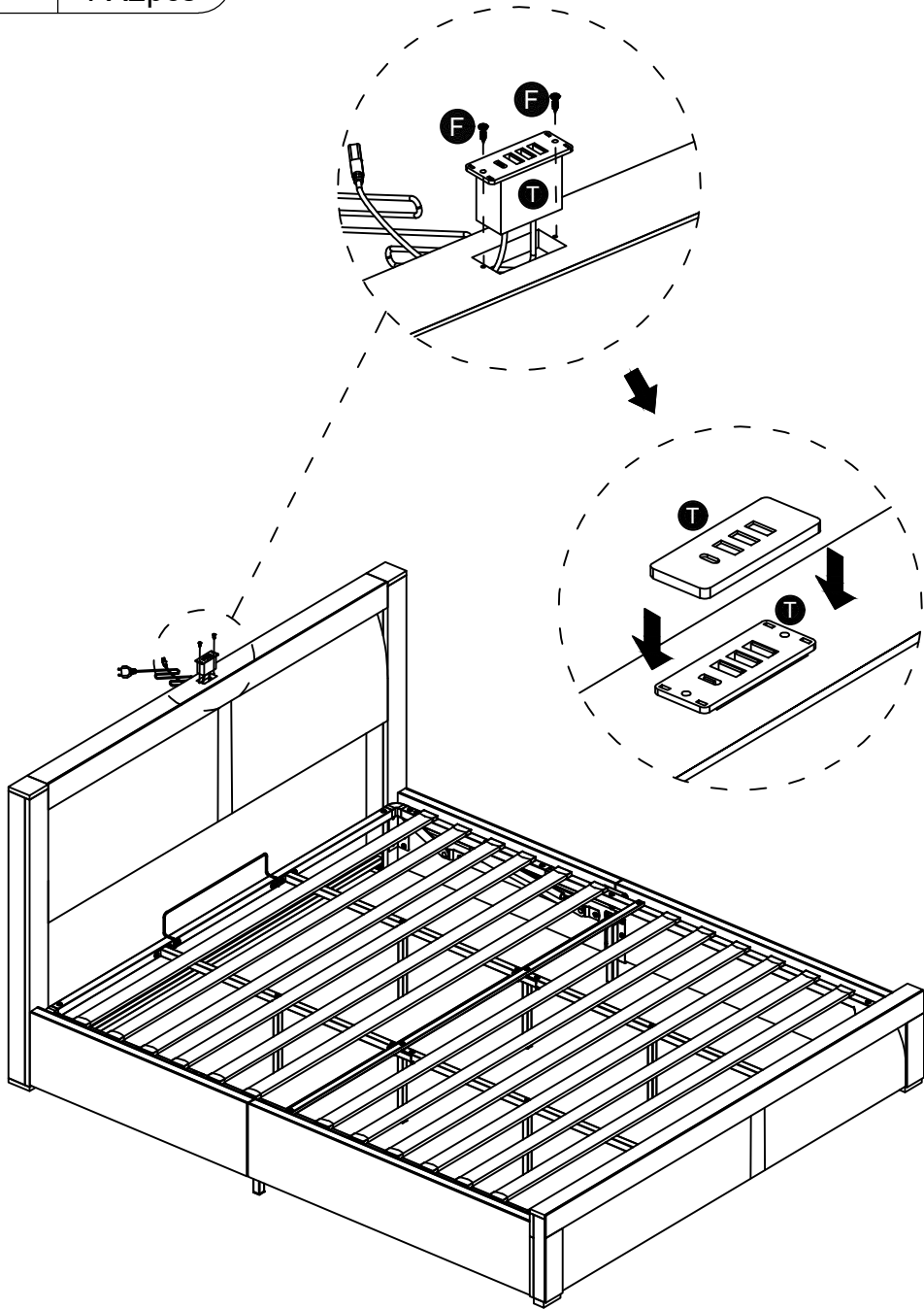

ST3X12
FX2pcs

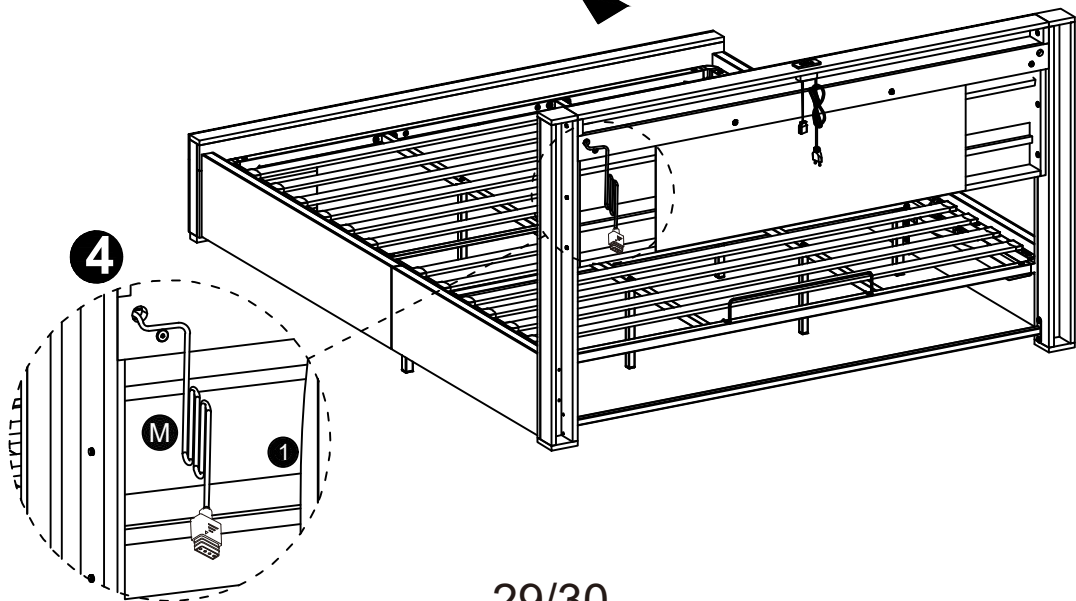
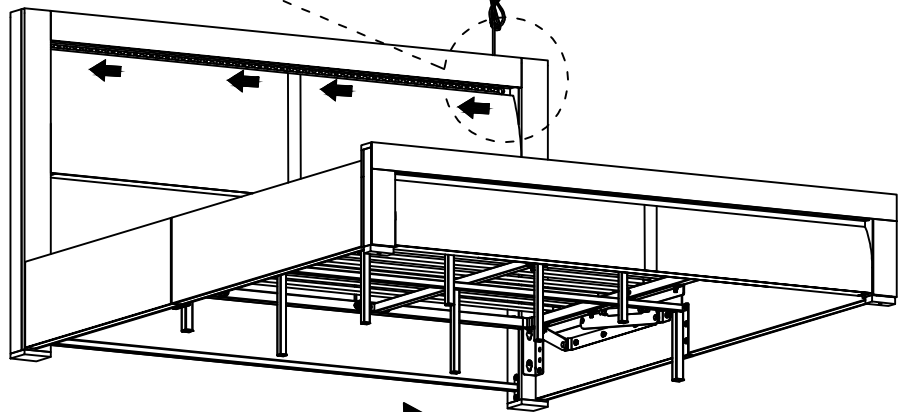
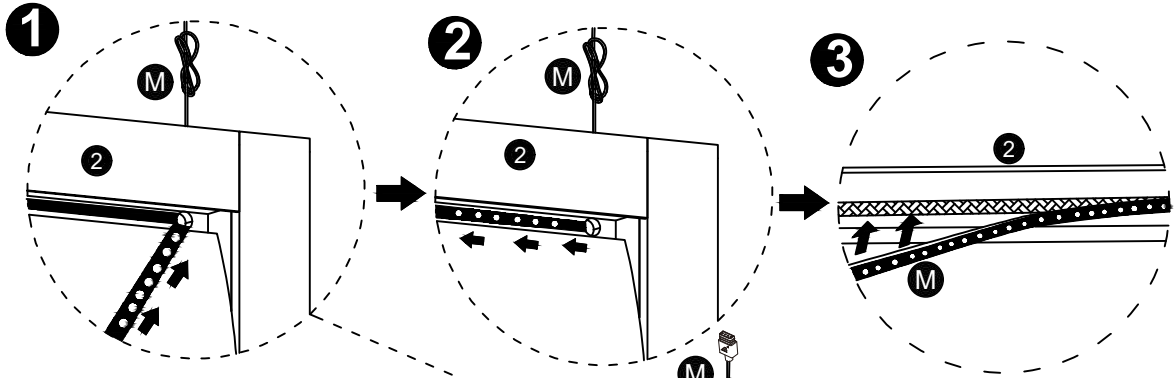
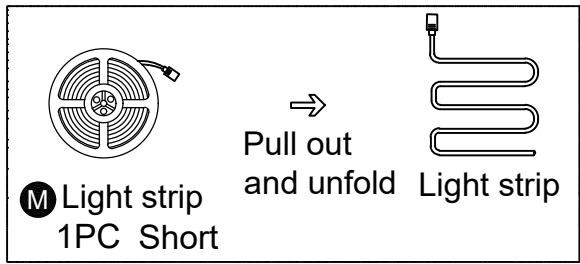

30



31  IX6pcs

K  Remote control
1PC

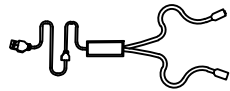
Q  Power cord
1PC

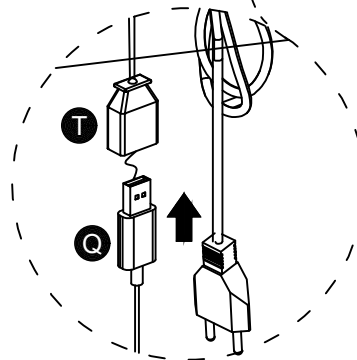
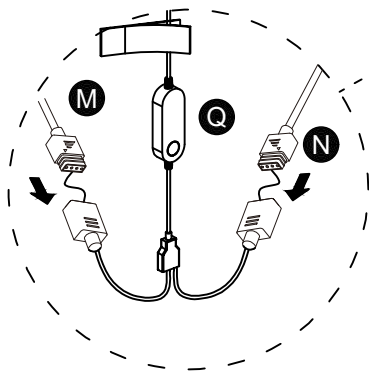
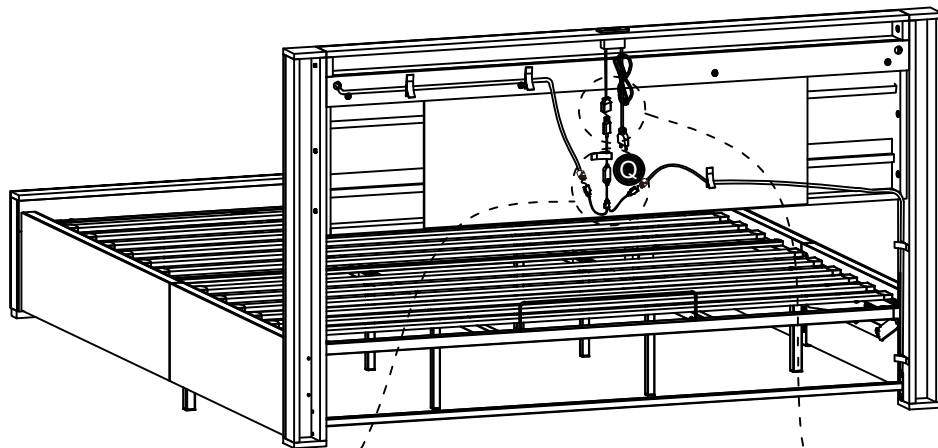
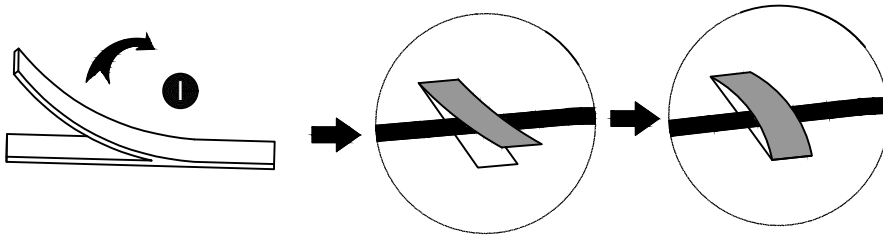

NOTE: The battery in the remote control requires you to purchase and install it yourself.
Model: CR2025 3.V

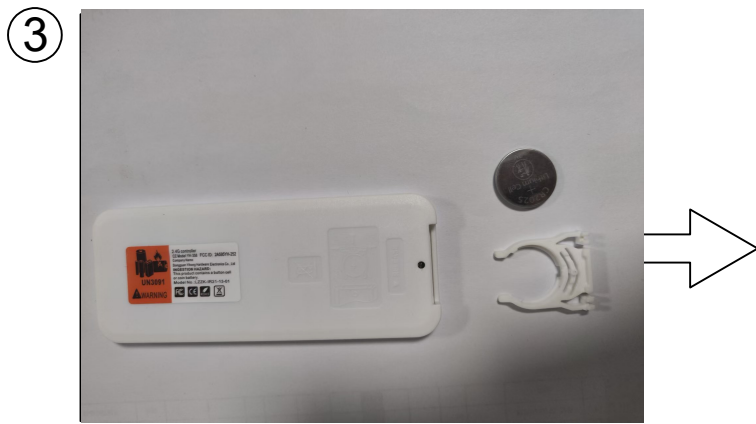
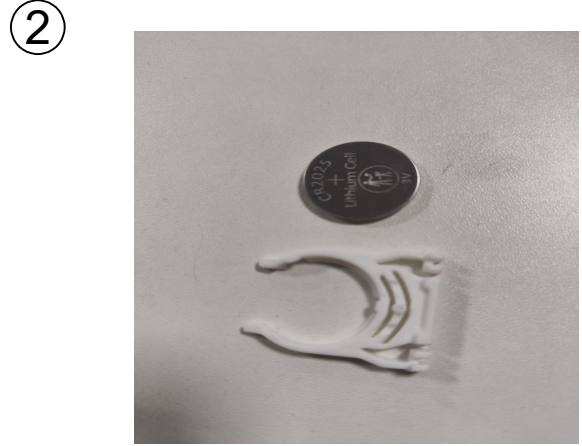

EN:Battery Safety Instructions

1. Do not dispose of used button batteries or remote controls in household trash. To protect the environment and prevent hazardous leakage, please follow these guidelines:
2. Remove button batteries after use and take them to a local battery recycling point or hazardous waste collection site.
3. Do not burn or dismantle the batteries to avoid explosion or toxic release.
4. If the remote control is no longer in use, please deliver it to a certified electronics recycling facility to promote resource reuse.
5. Keep out of reach of children to prevent accidental ingestion or injury.
6. This product does not include batteries; please purchase them separately. The compatible button cell model for the remote control is CR2025, 3V.
7. If the light strip is not working, please try replacing the battery first. If the issue persists, contact the seller for assistance.
8. **Keep the remote control away from children — keep it away from children!** If the battery is accidentally swallowed, seek medical attention immediately.

DE: Batteriesicherheitshinweise

1. Entsorgen Sie gebrauchte Knopfzellen oder Fernbedienungen nicht im Hausmüll. Um die Umwelt zu schützen und gefährliche Leckagen zu vermeiden, beachten Sie bitte die folgenden Hinweise:
2. Entfernen Sie die Knopfzelle nach dem Gebrauch und bringen Sie sie zu einer örtlichen Batteriesammelstelle oder einem Sondermüllentsorgungszentrum.
3. Batterien nicht verbrennen oder zerlegen, um Explosionen oder die Freisetzung giftiger Stoffe zu vermeiden.
4. Wenn die Fernbedienung nicht mehr verwendet wird, bringen Sie sie zu einer zertifizierten Elektronik-Recyclingstelle, um eine Wiederverwertung zu ermöglichen.
5. Außerhalb der Reichweite von Kindern aufbewahren, um versehentliches Verschlucken oder Verletzungen zu verhindern.
6. Dieses Produkt enthält keine Batterien. Bitte kaufen Sie diese separat. Das kompatible Knopfzellenmodell für die Fernbedienung ist CR2025, 3V.
7. Wenn der Lichtstreifen nicht funktioniert, versuchen Sie zunächst, die Batterie zu wechseln. Besteht das Problem weiterhin, kontaktieren Sie bitte den Verkäufer.
8. **Halten Sie die Fernbedienung unbedingt von Kindern fern — unbedingt fernhalten!** Wird die Batterie versehentlich verschluckt, suchen Sie sofort medizinische Hilfe auf.

FR:Instructions de sécurité pour les piles

1. Ne jetez pas les piles bouton usagées ou les télécommandes à la poubelle ménagère. Pour protéger l' environnement et éviter tout risque de fuite dangereuse, veuillez suivre les consignes suivantes :
 2. Retirez les piles bouton après usage et déposez-les dans un point de collecte local ou un centre de déchets dangereux.
 3. Ne brûlez pas et ne démontez pas les piles, cela pourrait entraîner une explosion ou libérer des substances toxiques.
 4. Si la télécommande n'est plus utilisée, déposez-la dans un centre de recyclage agréé pour appareils électroniques, afin de favoriser la réutilisation des ressources.
 5. Gardez hors de portée des enfants pour éviter tout risque d'ingestion accidentelle ou de blessure.
- 6.Ce produit ne contient pas de pile. Veuillez l'acheter séparément. Le modèle de pile bouton compatible pour la télécommande est CR2025,3V.
- 7.Si le ruban LED ne fonctionne pas, essayez d'abord de remplacer la pile. Si le problème persiste, contactez le vendeur.
- 8.**Tenez la télécommande éloignée des enfants — éloignez-la vraiment !** En cas d'ingestion accidentelle de la pile, consultez immédiatement un médecin.

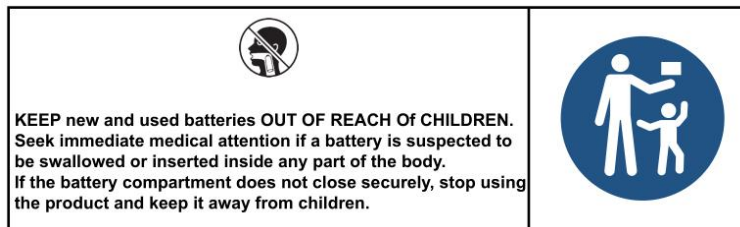

If a battery has been ingested, or there is a possibility one might have been ingested, please seek medical attention and inform the medical authorities that you suspect battery ingestion.

It's not always clear when a child has swallowed a button battery, as there are no specific symptoms. However, they might:

- cough, gag, or drool;
- seem to have a stomach bug or virus;
- vomit;
- complain of pain in their stomach, chest, or throat;
- appear tired or sluggish; and
- lose their appetite.

Since the signs aren't obvious, it's important to keep a close eye on loose, used, or spare button batteries in your home, as well as the products that contain them.



VERIFICATION OF CONFORMITY

No. : PTC25082917901E-RF01
Applicant : Dongguan Yihong Hardware electronics Co., LTD
Address : Room 1106,NO.2 Shangheng Road,Chang'an Town
Dongguan,Guangdong,523880 China
Manufacturer : Dongguan Yihong Hardware electronics Co., LTD
Address : Room 1106,NO.2 Shangheng Road,Chang'an Town
Dongguan,Guangdong,523880 China
Product : 2.4G Remote Controller
Trade Mark : -
Model : YH-629, YH-6181, YH-6183, YH-358
Ratings : DC 3V

The submitted sample of the above equipment has been tested and found to comply with the following European Directive:

Radio equipment Directive - 2014/53/EU

The standard(s) used for showing compliance with the essential requirements:

Applicable Standard(s)	Test Report(s) Number
ETSI EN 300 440 V2.2.1 (2018-07)	PTC25082917901E-EM01
ETSI EN 301 489-1 V2.2.3 (2019-11)	PTC25082917901E-EM02
ETSI EN 301 489-3 V2.3.2 (2023-01)	
EN 62479:2010	PTC25082917901E-EM03
EN IEC 62368-1:2020+A11:2020	PTC25082917901S-LD01

This verification is part of the full test report(s) and should be read in conjunction with it. This verification is based on an evaluation of one sample of above mentioned product. It does not imply assessment of the production of the product. Without the written approval of Precise Testing & Certification (Guangdong) Co., Ltd., this verification is not permitted to be reproduced, except in full. It is not permitted to use the test lab's logo. Provided that other applicable Directive requirements are satisfied, the manufacturer (or the European authorized representative), may draw up an EC/EEA Declaration of Conformity and affix the CE-marking to each conforming product.



Jacky Ou

Jacky Ou
Manager
Date: 2025-09-23



Verification of Compliance

Verification No.:	MK23020083-P01C01
Name and address of Applicant:	Shenzhen Hongzhengyu Technology Co., LTD Shenzhen baoan district rock street industrial science and technology industrial park of 2 Haitian lanyu 3 5 floor of A
Name and address of Manufacturer:	Shenzhen Hongzhengyu Technology Co., LTD Shenzhen baoan district rock street industrial science and technology industrial park of 2 Haitian lanyu 3 5 floor of A
Product name:	Lamp strip HZY-2835-120D-12V, HZY-2835-30D-5V, HZY-2835-60D-5V, HZY-2835-120D-5V, HZY-2835-60D-12V, HZY-2835-60D-24V, HZY-2835-120D-24V, HZY-2835RGB-60D-5V, HZY-2835RGB-60D-12V, HZY-5050-30D-5V, HZY-5050-60D-5V, HZY-5050-30D-12V, HZY-5050-60D-12V, HZY-5050-60D-24V, HZY-5050RGB-30D-5V, HZY-5050RGB-60D-5V, HZY-5050RGB-30D-12V, HZY-5050RGB-60D-12V, HZY-5050RGB-60D-24V
Product model(s):	
Product trademark:	N/A

This verification confirms that the product meets the requirements of the following standard.

The conformity was demonstrated based on following standard(s) listed by European Commission as harmonized with Directive RoHS 2.0 Directive (EU) 2015/863 and (EU)2017/2102 amending Annex II to Directive 2011/65/EU

IEC 62321-1:2013	IEC 62321-3-1:2013
IEC 62321-4:2013/AMD1:2017	IEC 62321-5:2013
IEC 62321-6:2015	IEC 62321-7-1:2015
IEC 62321-7-2:2017	IEC 62321-8:2017

The verification has been carried out in accordance with individual rules and conditions agreed with the applicant. Evaluation has been carried out in accordance with:

Test report(s) No.:	MK23020083-P01C01
Test conducted by:	TMC Testing Services (Shenzhen) Co., Ltd.
Verification issue date:	February 25, 2023

Notes:

This verification refers to the above mentioned product and its conformity in regards of above mentioned standard(s) was proven on test sample.

This verification does not imply meeting all essential requirements, assessment of the series-production or any other restricted Notified Bodies conformity assessment procedure appropriate for the product.

This verification holder shall use this verification in connection to verification of conformity and technical data relevant for the product the verification was issued.

TMC Testing Services (Shenzhen) Co., Ltd.

t:86-755-86642861 cert@tmc-lab.com www.tmc-lab.com

1st Floor, Block A1, Zone A, Xinshidai Gongrong Industrial Park, No. 2, Shihuan Road, Shiyuan Street, Baoan District, Shenzhen, China



Shenzhen ZKT Technology Co., Ltd.

1/F, No. 101, Building B, No. 6, Tangwei Community Industrial Avenue,
Fuhai Street, Bao'an District, Shenzhen, China



Certificate of Compliance

Certificate Number: ZKT-250327L5653C

Certificate's Holder : Guangdong Zhangong Electric Technology Co., Ltd
701, Building 29, zhifuyuan Industrial Zone, Xingtan town,
Shunde District, Foshan City, Guangdong Province

Manufacturer : Guangdong Zhangong Electric Technology Co., Ltd
701, Building 29, zhifuyuan Industrial Zone, Xingtan town,
Shunde District, Foshan City, Guangdong Province

Trade Mark : /

Product : Mountable USB Hub/USB CHARGER

Model(s) : ZG-USB-12-B
ZG-USB-12, ZG-USB-12-C

Test Standard : EN 61558-2-16:2009+A1:2013 used in conjunction with
EN IEC 61558-1:2019

This Attestation of Compliance is issued on a voluntary basis for electrical equipment below the voltage limits of Low Voltage Directive 2014/35/EU. The essential requirements are fulfilled accordingly based on the technical specifications applicable at the time of issuance. See also notes overleaf. It is only valid in connection with the test report number: ZKT-250327L5653S.



This Certificate of Conformity is based on single evaluation of the submitted sample(s) of the above mentioned product. It does not imply an assessment of the whole product and relevant Directives to be observed.

Shenzhen ZKT Technology Co., Ltd.

1/F, No. 101, Building B, No. 6, Tangwei Community Industrial Avenue,
Fuhai Street, Bao'an District, Shenzhen, China



Certificate of Compliance

Certificate Number: ZKT-25070215182C

Certificate's Holder : Dongguan Yihong Hardware Electronics Co., Ltd
Room 1106, No.2, Shangheng Road, Chang' an Town,
Dongguan

Manufacturer : Dongguan Yihong Hardware Electronics Co., Ltd
Room 1106, No.2, Shangheng Road, Chang' an Town,
Dongguan

Trade Mark : N/A

Product : LED controller

Model(s) : YH-6183
YH-252, YH-284, YH-290, YH-287, YH-358, YH-360, YH-6180,
YH-6184

Requirement	Standard	Report No.
Art.3.1(a) Safety	EN IEC 62368-1:2024+A11:2024	ZKT-25070215183S
Art.3.1(a) Health	EN IEC 62311:2020 EN 50665:2017	ZKT-25070215182E-1
Art.3.1(b) EMC	ETSI EN 301 489-1 V2.2.3 (2019-11) ETSI EN 301 489-17 V3.3.0 (2024-07)	ZKT-25070215182E-2
Art.3.2 Radio	ETSI EN 300 328 V2.2.2 (2019-07)	ZKT-25070215182E-3

This Attestation of Compliance is issued on a voluntary basis for electrical equipment below the voltage limits of Radio Equipment Directive (RED) 2014/53/EU. The essential requirements are fulfilled accordingly based on the technical specifications applicable at the time of issuance.



This Certificate of Conformity is based on single evaluation of the submitted sample(s) of the above mentioned product. It does not imply an assessment of the whole product and relevant Directives to be observed.

DECLARATION OF CONFORMITY

We hereby,

Declare that our products listed below have fulfilled with relevant requirements of European Directives:

1. Company information:

Name	Dongguan Yihong Hardware electronics Co., LTD
Address	Room 1106,NO.2 Shangheng Road,Chang'an Town,Dongguan,Guangdong, 523880 China

2. Manufacture information:

Name	Dongguan Yihong Hardware electronics Co., LTD
Address	Room 1106,NO.2 Shangheng Road,Chang'an Town,Dongguan,Guangdong, 523880 China

3. Factory information:

Name	Dongguan Yihong Hardware electronics Co., LTD
Address	Room 1106,NO.2 Shangheng Road,Chang'an Town,Dongguan,Guangdong, 523880 China

4. Agent information:

Name	
Address	
Contact person	
Tel. No.	
E-mail	

5. Product information

Product Name	2.4G Remote Controller
Trade Mark	/
Model	YH-629
Ratings	DC 3V

6. Conformity information:

The submitted sample(s) of the above products has(have) been tested and found to comply with the following European Directives:

European Directives	Standards	Test Report(s) Number
Radio equipment Directive -2014/53/EU	ETSI EN 300 440 V2.2.1 (2018-07) ETSI EN 301 489-1 V2.2.3 (2019-11) ETSI EN 301 489-3 V2.3.2 (2023-01) EN 62479:2010 EN IEC 62368-1:2020+A11:2020	PTC25082917901E-EM01 PTC25082917901E-EM02 PTC25082917901E-EM03 PTC25082917901S-LD01



7. Test lab information:

Test lab	Precise Testing & Certification(Guangdong)Co.,Ltd
Lab address	Building 1, No.6, Tongxin Road, Dongcheng Street, Dongguan, Guangdong, China

The marking as show below affixed on the products after all necessary conformity documentations have been prepared.



8. Obligation

The Manufacturer or the authorized representative's obligation is to make sure all requirements set in this declaration letter be fulfilled.

The CEO and the Owner of (Zeng Wenfeng) take the sole responsibility of that product.

Signature: *Zeng Wenfeng*

Address: Room 1106, NO.2 Shangheng Road, Chang'an Town, Dongguan, Guangdong, 523880 China

Date: *2025.10.18*





Importeur	Decobus Handel GmbH		
Adresse	Innungsstraße 9,21244 Buchholz,Deutschland		
Email/URL	https://www.decobusgroup.de		
Hersteller	Dongguan Yihong Hardware Electronics Co.. Ltd		
Adresse	Room 1106.No.2,Shangheng Road, Chang an Town		
Email/URL	414564409@qq.com		
Partienumm	202507		
Hergestellt in	China		
Produkt:LED Controller Modell: YH-358			
Nennspannung:5 V Nennfrequenz: 50/60Hz Leistung: 15W			
	<table border="1"><tr><td>EC</td><td>REP</td></tr></table> Decobus Handel GmbH Innungsstraße 9,21244 Buchholz,Deutschland https://www.decobusgroup.de	EC	REP
EC	REP		



Importeur	Decobus Handel GmbH		
Adresse	Innungsstraße 9,21244 Buchholz,Deutschland		
Email/URL	https://www.decobusgroup.de		
Hersteller	Shenzhen Hongzhengyu Technology Co., LTD		
Adresse	Shenzhen baoan district rock street industrial science and technology industrial park of 2 Haitian lanyu 3 5 floor of A		
Email/URL	522495222@qq.com		
Partienumm	202507		
Hergestellt in	China		
Produkt:LED soft light strip Model:HZY-5050RGB-30D-5V			
Nennspannung:5 V Nennfrequenz: 50/60Hz Leistung: 4.5W/M			
	<table border="1"><tr><td>EC</td><td>REP</td></tr></table> Decobus Handel GmbH Innungsstraße 9,21244 Buchholz,Deutschland https://www.decobusgroup.de	EC	REP
EC	REP		

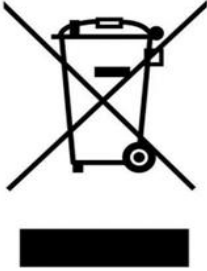

Importeur	Decobus Handel GmbH		
Adresse	Innungsstraße 9,21244 Buchholz,Deutschland		
Email/URL	https://www.decobusgroup.de		
Hersteller	Dongguan Yihong Hardware Electronics Co.. Ltd		
Adresse	Room 1106.No.2,Shangheng Road, Chang an Town		
Email/URL	414564409@qq.com		
Partienumm	202507		
Hergestellt in	China		
Produkt: 2.4G Remote Controller Model: YH-629			
Rating: DC 3V			
	<table border="1"><tr><td>EC</td><td>REP</td></tr></table> Decobus Handel GmbH Innungsstraße 9,21244 Buchholz,Deutschland https://www.decobusgroup.de	EC	REP
EC	REP		



Importeur	Decobus Handel GmbH		
Adresse	Innungsstraße 9,21244 Buchholz,Deutschland		
Email/URL	https://www.decobusgroup.de		
Hersteller	Guangdong Zhangong Electrical Technology Co., LTD		
Adresse	701, Building 29, Zhifu Garden, Xingtan Town, Shunde District, Foshan City		
Email/URL	610488898@qq.com		
Partienumm	202507		
Hergestellt in	China		
Produkt: MOUNTABLE USB Hub/USB CHARGER Model:ZG-USB-12			
Input: 100-240V 50/60HZ			
	<table border="1"><tr><td>EC</td><td>REP</td></tr></table> Decobus Handel GmbH Innungsstraße 9,21244 Buchholz,Deutschland https://www.decobusgroup.de	EC	REP
EC	REP		