

31101-B05-2

DUBI
Möbel

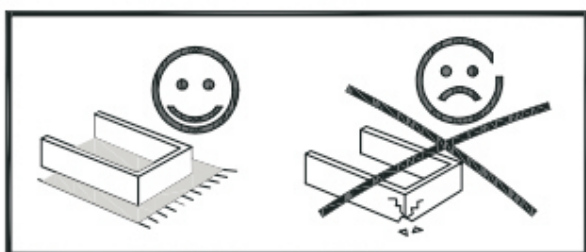
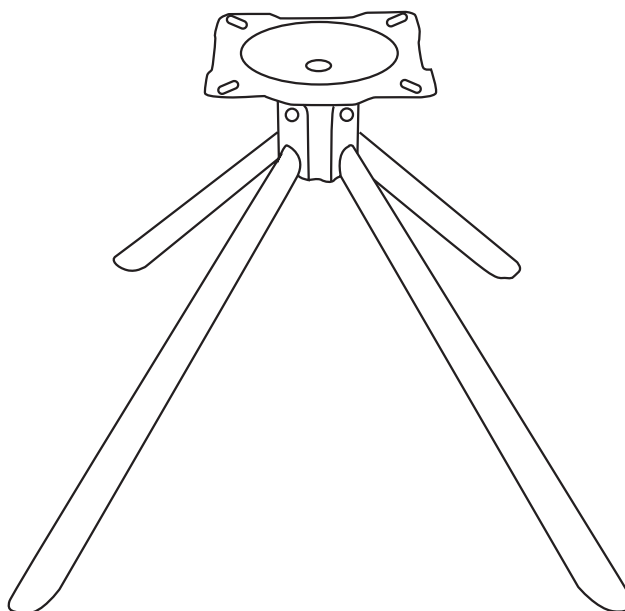
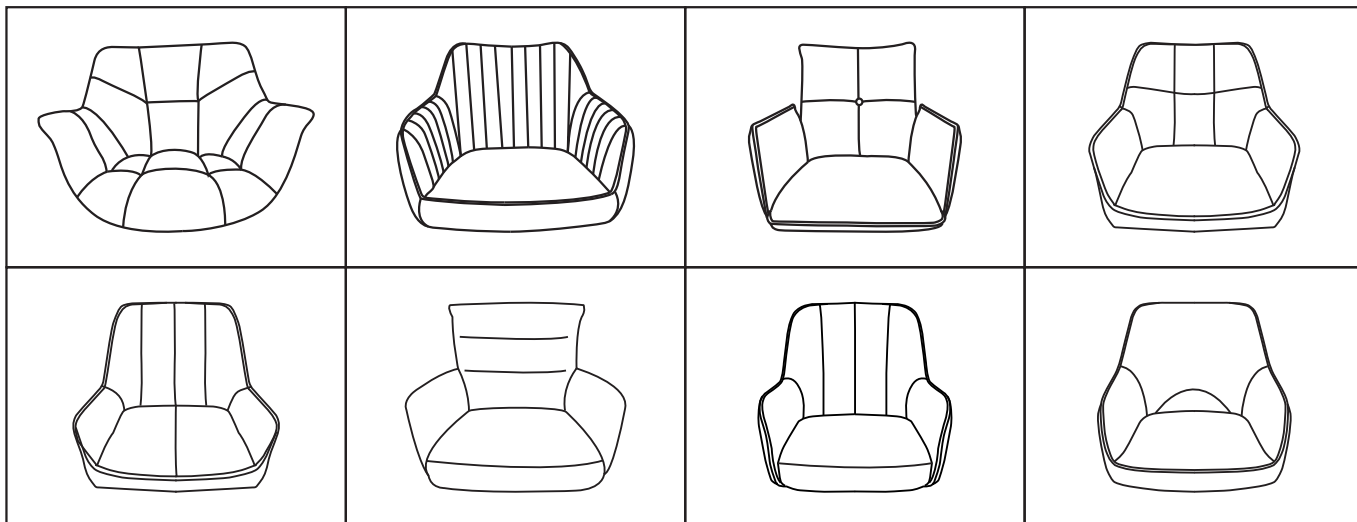

DUBI Möbel

A

x4

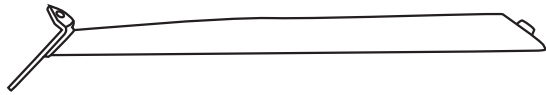

B

x4

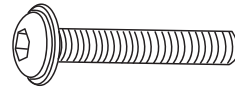

M6x25mm

C

x8

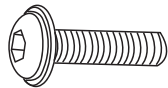

M6x14mm

D

x4

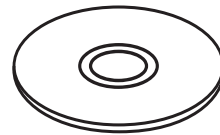

E

x1

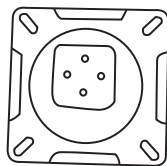

F

x1

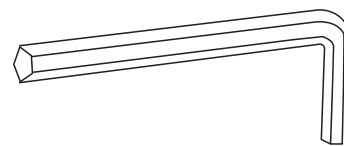

M6

G

x2



H

x8



I

x8



1

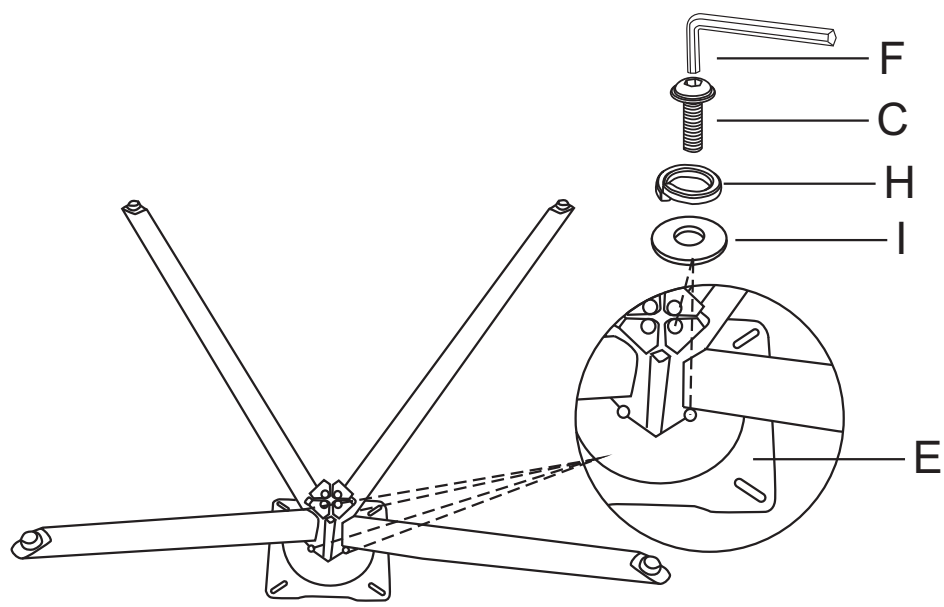
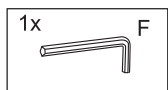
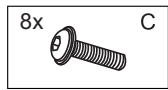
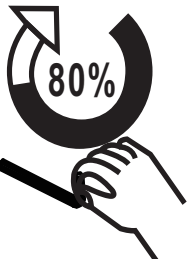

2

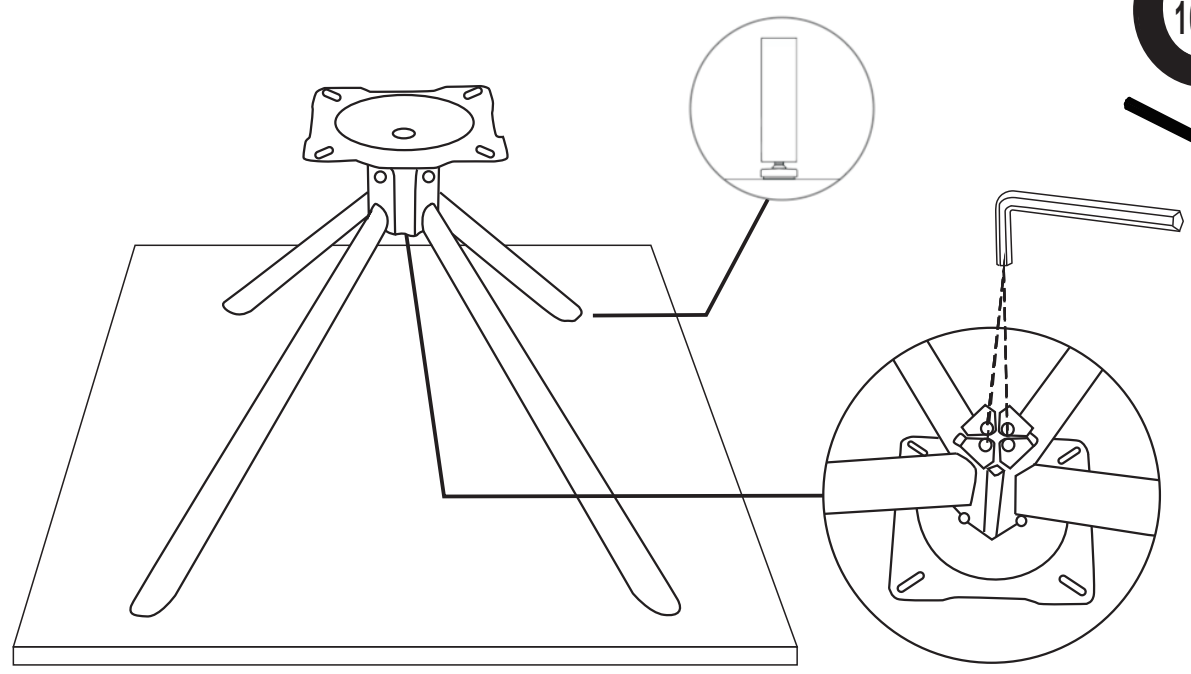
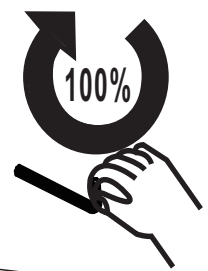

3

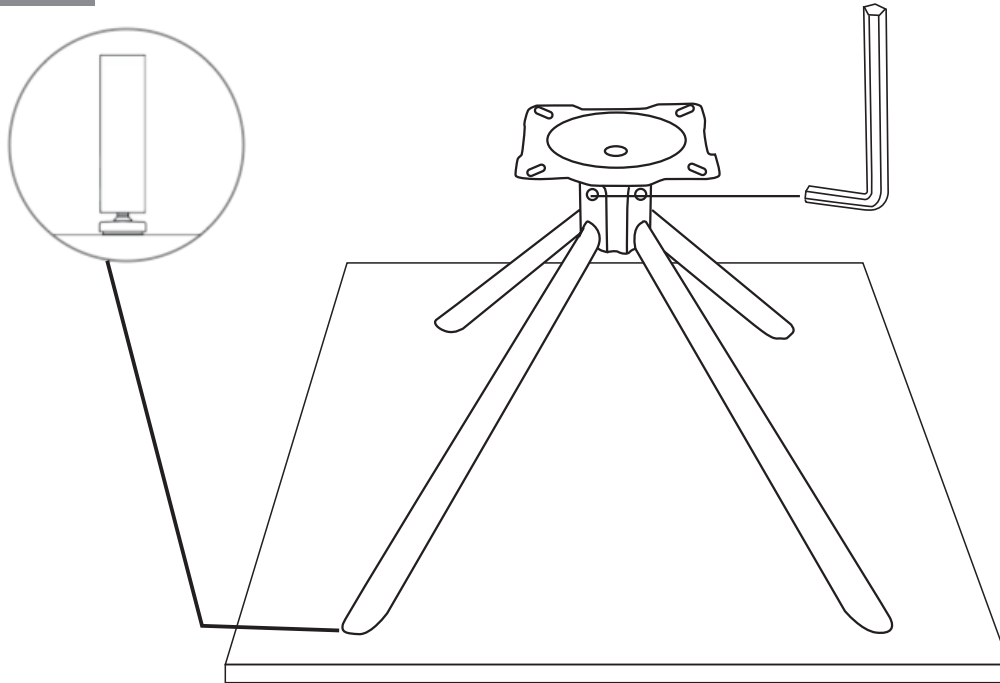

DE: Stabilitätshinweis

1. **Locker anziehen:** Alle Schrauben zuerst nur **ca. 80% festziehen** – Beine sollen noch beweglich sein.
2. **Ausrichten:** Stuhl auf **ebene Fläche** stellen, kurz auf die Sitzfläche drücken, bis **alle Beine fest aufliegen**.
3. **Festziehen:** Dann alle Schrauben **endgültig festziehen**, aber **nicht überdrehen**.

Pflege: Nach **4 Wochen** und dann **alle 6 Monate** Schrauben prüfen und ggf. nachziehen.

EN: Stability Notice

1. **Tighten loosely:** Tighten all screws only about **80%** at first – the legs should still be movable.
2. **Align:** Place the chair on a **flat, level surface**, press lightly on the seat until all legs are stable and touching the floor.
3. **Tighten fully:** Then tighten all screws **completely**, but **do not overtighten**.





Maintenance: Check and retighten screws **after 4 weeks** and then **every 6 months**.

FR: Avis de stabilité

1. **Serrer légèrement:** Serrez d'abord toutes les vis à environ **80%** – les pieds doivent rester légèrement mobiles.
2. **Ajuster:** Placez la chaise sur une **surface plane et stable**, appuyez légèrement sur l'assise jusqu'à ce que les quatre pieds reposent bien au sol.
3. **Serrer complètement:** Serrez ensuite toutes les vis à **fond**, mais **sans forcer**.

Entretien: Vérifiez et resserrez les vis **après 4 semaines**, puis **tous les 6 mois**.

4

- 4x B 
- 4x D 
- 1x F 
- 2x G 

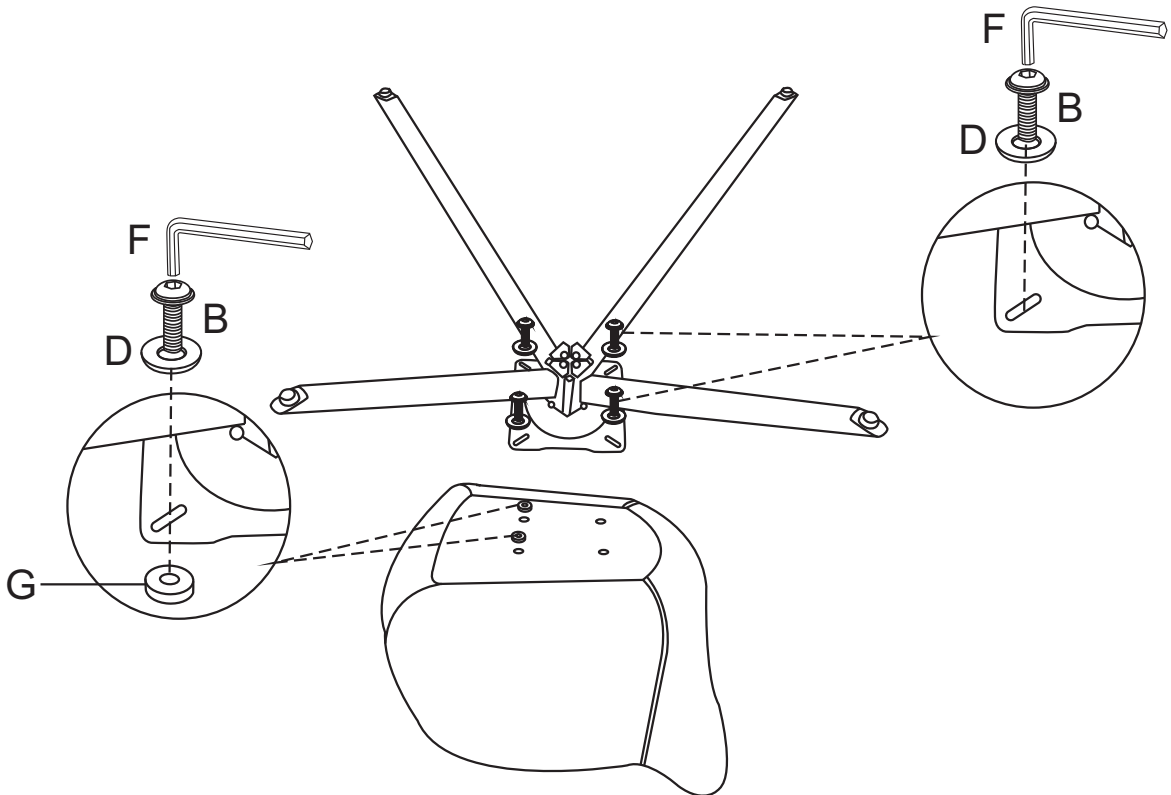
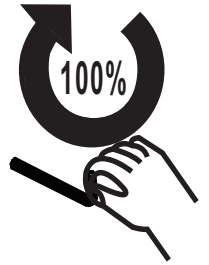

5

