

Assembly Instruction

———— CBN112D06-DE ————

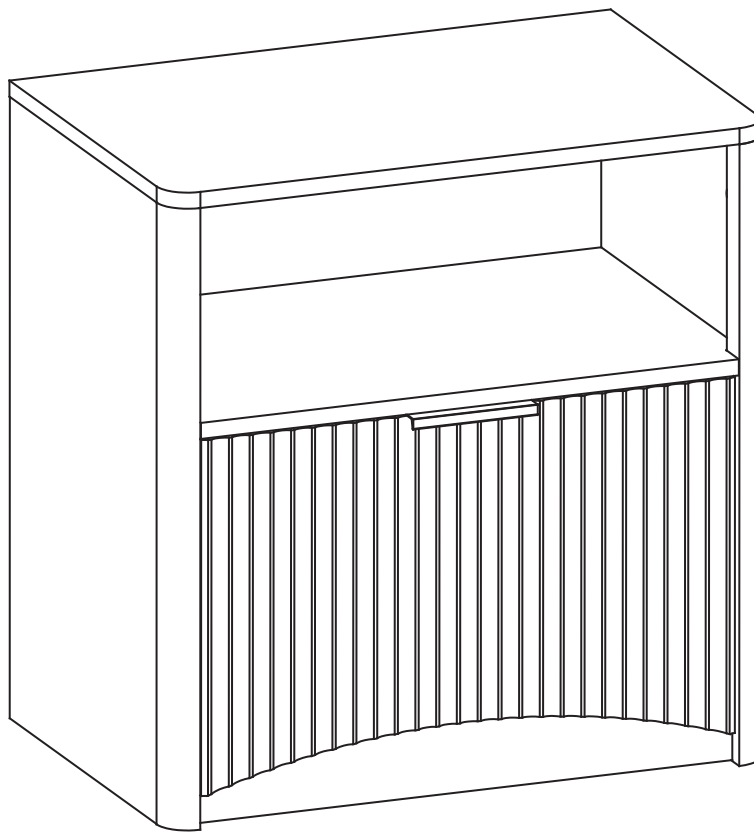

General Guidelines

- Please read the following instruction carefully and use the product accordingly.
- Please keep this manual and hand it over when you transfer the product.
- This summary may not include every detail of all variations and considered steps. Please contact us when further information and help are needed.

Notes

- The product is intended for indoor use only. The product must be assembled and used in accordance with the provisions of the manual. Personal injury an/or damage to product may occur if products are used outside of their intended purposes and/or if products have been changed/modified from their original design. The seller does not assume any responsibility or liability with respect to any injury/damage caused by incorrect assembly or improper use.
- Avoid long-term exposure to humid environments to prevent mildew.
- Keep the product away from fire sources and high temperatures. Do not expose the product to direct sunlight.
- Do not place any hot objects on the surface of the product.
- If there are any defective or missing parts after unpacking, please cease assembly immediately and contact us.
- Please assemble the item on a spacious surface and do not place the unwrapped product directly on the ground to avoid product damage.
- Please do not stand or sit on the wooden boards.
- Please wear gloves during the assembly and/or disassembly process to avoid scratches from any sharp edges.
- Please match the corresponding part and fitting based on the part number in the manual.
- If the part does not match with the fitting, please check the piece as specified in this manual.
- During assembly, first loosely align all screws with the corresponding pre-drilled holes and then tighten the screws one by one.
- Periodically inspect screw tightness while the product is in use. If necessary, retighten to ensure structural integrity.
- If you accidentally spill water or another liquid on the surface, immediately wipe clean with a dry towel.
- Please keep the product away from sharp, pointed objects and corrosive substances to prevent product damage.
- Please place this item on level, solid ground during use.

Warnings

- During assembly, keep all small parts out of the reach of children. It may be fatal if swallowed or inhaled.
- Children should not climb or play on the product in order to avoid tipping over the furniture and causing serious injury.
- To avoid the potential dangers of suffocation, please keep all parts and packaging (film, plastic bags, foam, etc.) away from babies and children.
- Keep sharp objects and corrosive items away from the product to avoid any damage or injury.
- Do not shake or move violently during use to avoid tipping over the product.

Instructions Générales

- Veuillez lire attentivement les instructions suivantes et utiliser le produit en conséquence.
- Veuillez conserver ce manuel et le remettre en cas de transfert du produit.
- Ce résumé peut ne pas inclure tous les détails de toutes les variations et étapes envisagées. Veuillez nous contacter pour toute information complémentaire ou assistance nécessaire.

Notes

- Ce produit est conçu uniquement pour une utilisation en intérieur. Le produit doit être assemblé et utilisé conformément aux dispositions de ce manuel. Des blessures personnelles et/ou des dommages au produit peuvent survenir si le produit est utilisé en dehors de sa destination prévue et/ou s'il a été modifié par rapport à sa conception d'origine. Le vendeur n'assume aucune responsabilité ni obligation concernant tout dommage/blessure causé(e) par un assemblage incorrect ou une utilisation inappropriée.
- Évitez une exposition prolongée à des environnements humides pour prévenir l'apparition de moisissures.
- Tenez le produit éloigné de sources de chaleur et de températures élevées. N'exposez pas le produit à la lumière directe du soleil.
- Ne placez aucun objet chaud sur la surface du produit.
- S'il manque des pièces ou si certaines sont défectueuses après le déballage, veuillez cesser immédiatement l'assemblage et nous contacter.
- Veuillez assembler l'article sur une surface spacieuse et ne pas placer le produit non emballé directement sur le sol pour éviter de l'endommager.
- Veuillez ne pas vous tenir debout ou vous asseoir sur les planches en bois.
- Veuillez porter des gants pendant le processus d'assemblage et/ou de démontage pour éviter les égratignures causées par les arêtes vives.
- Veuillez faire correspondre la pièce et la fixation en fonction du numéro de pièce indiqué dans le manuel.
- Si la pièce ne correspond pas à la fixation, veuillez vérifier la pièce comme spécifié dans ce manuel.
- Lors de l'assemblage, alignez d'abord toutes les vis sans les serrer dans les trous pré-perforés correspondants, puis serrez les vis une par une.
- Vérifiez périodiquement le serrage des vis lorsque le produit est utilisé. Si nécessaire, resserrez-les pour garantir la stabilité structurelle.
- Si vous renversez accidentellement de l'eau ou un autre liquide sur la surface, essuyez immédiatement avec une serviette sèche.
- Veuillez tenir le produit à l'écart d'objets pointus, tranchants et de substances corrosives pour éviter tout dommage.
- Veuillez placer cet article sur un sol niveau et stable pendant son utilisation.

Avertissements

- Pendant l'assemblage, gardez toutes les petites pièces hors de portée des enfants. L'ingestion ou l'inhalation peut être mortelle.
- Les enfants ne doivent pas grimper ou jouer sur le produit afin d'éviter que le meuble ne bascule et ne cause des blessures graves.
- Pour éviter les risques potentiels d'étouffement, veuillez tenir toutes les pièces et emballages (film, sacs plastique, mousse, etc.) hors de portée des bébés et des enfants.
- Tenez les objets tranchants et les articles corrosifs éloignés du produit pour éviter tout dommage ou blessure.
- Ne secouez pas et ne déplacez pas violemment le produit pendant son utilisation pour éviter qu'il ne bascule.

Allgemeine Hinweise

- Bitte lesen Sie die folgenden Anweisungen sorgfältig und verwenden Sie das Produkt entsprechend.
- Bewahren Sie diese Anleitung auf und geben Sie sie bei Weitergabe des Produkts weiter.
- Diese Zusammenfassung enthält möglicherweise nicht jedes Detail aller Variationen und berücksichtigten Schritte. Bitte kontaktieren Sie uns, wenn Sie weitere Informationen oder Hilfe benötigen.

Hinweise

- Dieses Produkt ist ausschließlich für die Innenraumgebrauch bestimmt. Das Produkt muss gemäß den Bestimmungen dieser Anleitung montiert und verwendet werden. Personenverletzungen und/oder Produktschäden können auftreten, wenn das Produkt außerhalb seines bestimmungsgemäßen Gebrauchs verwendet wird und/oder wenn das Produkt gegenüber seinem Originaldesign verändert/modifiziert wurde. Der Verkäufer übernimmt keinerlei Verantwortung oder Haftung für Schäden/Verletzungen, die durch fehlerhafte Montage oder unsachgemäße Verwendung verursacht werden.
- Vermeiden Sie längere Exposition in feuchter Umgebung, um Schimmelbildung vorzubeugen.
- Bewahren Sie das Produkt fern von Hitzequellen und hohen Temperaturen. Setzen Sie das Produkt nicht direktem Sonnenlicht aus.
- Platzieren Sie keine heißen Gegenstände auf der Oberfläche des Produkts.
- Falls nach dem Auspacken Teile fehlen oder defekt sind, brechen Sie die Montage sofort ab und setzen Sie sich mit uns in Verbindung.
- Führen Sie die Montage auf einer geräumigen Fläche durch und stellen Sie das ausgepackte Produkt nicht direkt auf den Boden, um Beschädigungen zu vermeiden.
- Bitte nicht auf den Holzplatten stehen oder sitzen.
- Tragen Sie während des Montage- und/oder Demontagevorgangs Handschuhe, um Schnittverletzungen durch scharfe Kanten zu vermeiden.
- Ordnen Sie die entsprechenden Teile und Beschläge anhand der Teilenummer in der Anleitung zu.
- Wenn das Teil nicht zum Beschlag passt, überprüfen Sie das Stück wie in dieser Anleitung angegeben.
- Richten Sie während der Montage zunächst alle Schrauben lose in den entsprechenden vorgebohrten Löchern aus und ziehen Sie die Schrauben dann nacheinander fest.
- Überprüfen Sie regelmäßig den Sitz der Schrauben während der Nutzung des Produkts. Ziehen Sie sie bei Bedarf nach, um die Stabilität der Konstruktion zu gewährleisten.
- Wenn Sie versehentlich Wasser oder eine andere Flüssigkeit auf die Oberfläche verschütten, wischen Sie diese sofort mit einem trockenen Tuch ab.
- Bewahren Sie das Produkt fern von scharfen, spitzen Gegenständen und ätzenden Substanzen auf, um Beschädigungen zu vermeiden.
- Stellen Sie diesen Gegenstand während der Benutzung auf einen ebenen und stabilen Untergrund.

Warnhinweise

- Bewahren Sie während der Montage alle Kleinteile für Kinder unzugänglich auf. Verschlucken oder Einatmen kann tödlich sein.
- Kinder sollten nicht auf dem Produkt klettern oder spielen, um ein Umstürzen der Möbel und schwerwiegende Verletzungen zu vermeiden.
- Um die Gefahr des Erstickens zu vermeiden, bewahren Sie alle Teile und Verpackungsmaterialien (Folie, Plastiktüten, Schaumstoff usw.) außerhalb der Reichweite von Babys und Kleinkindern auf.
- Halten Sie scharfe Gegenstände und ätzende Substanzen vom Produkt fern, um Beschädigungen oder Verletzungen zu vermeiden.
- Schütteln oder rütteln Sie das Produkt während der Benutzung nicht, um ein Umkippen zu verhindern.

Linee Guida Generali

- Leggere attentamente le seguenti istruzioni e utilizzare il prodotto di conseguenza.
- Conservare questo manuale e consegnarlo in caso di trasferimento del prodotto.
- Questo riepilogo potrebbe non includere ogni dettaglio di tutte le variazioni e le fasi previste. Contattarci per ulteriori informazioni o assistenza.

Note

- Il prodotto è destinato esclusivamente all'uso interno. Il prodotto deve essere montato e utilizzato in conformità alle disposizioni del presente manuale. Potrebbero verificarsi infortuni personali e/o danni al prodotto se i prodotti vengono utilizzati al di fuori delle loro finalità previste e/o se i prodotti sono stati modificati rispetto al progetto originale. Il venditore non si assume alcuna responsabilità o obbligo per eventuali infortuni/danni causati da un montaggio errato o da un uso improprio.
- Evitare l'esposizione prolungata ad ambienti umidi per prevenire la formazione di muffe.
- Tenere il prodotto lontano da fonti di calore e temperature elevate. Non esporre il prodotto alla luce solare diretta.
- Non posizionare oggetti caldi sulla superficie del prodotto.
- Se dopo aver spaccettato il prodotto si riscontrano parti difettose o mancanti, interrompere immediatamente il montaggio e contattarci.
- Assemblare l'articolo su una superficie spaziosa e non appoggiare il prodotto non imballato direttamente sul terreno per evitare danni.
- Non stare in piedi o sedersi sulle assi di legno.
- Indossare i guanti durante le operazioni di montaggio e/o smontaggio per evitare graffi da bordi taglienti.
- Abbinare le parti e i raccordi corrispondenti in base al numero di parte indicato nel manuale.
- Se la parte non corrisponde al raccordo, verificare il pezzo come specificato in questo manuale.
- Durante il montaggio, allineare prima tutte le viti senza stringere nei fori preforati corrispondenti e poi serrarle una ad una.
- Controllare periodicamente la tenuta delle viti durante l'utilizzo del prodotto. Se necessario, serrarle nuovamente per garantire la stabilità strutturale.
- Se si rovescia accidentalmente acqua o altro liquido sulla superficie, asciugare immediatamente con un panno asciutto.
- Tenere il prodotto lontano da oggetti appuntiti, taglienti e sostanze corrosive per prevenire danni.
- Posizionare l'articolo su un terreno piano e stabile durante l'uso.

Avvertenze

- Durante il montaggio, tenere tutte le piccole parti fuori dalla portata dei bambini. L'ingestione o l'inalazione può essere fatale.
- I bambini non devono arrampicarsi o giocare sul prodotto per evitare che il mobile si ribalti e causi lesioni gravi.
- Per evitare i pericoli di soffocamento, tenere tutte le parti e gli imballaggi (pellicola, sacchetti di plastica, schiuma, ecc.) fuori dalla portata di neonati e bambini.
- Tenere oggetti taglienti e sostanze corrosive lontano dal prodotto per evitare danni o infortuni.
- Non scuotere o spostare bruscamente durante l'uso per evitare il ribaltamento del prodotto.

Directrices Generales

- Lea atentamente las siguientes instrucciones y utilice el producto en consecuencia.
- Guarde este manual y entréguelo en caso de transferencia del producto.
- Este resumen puede no incluir todos los detalles de las variaciones o pasos considerados. Contáctenos si necesita información adicional o ayuda.

Notas

- El producto está destinado exclusivamente para uso en interiores. El producto debe ser ensamblado y utilizado de acuerdo con lo dispuesto en este manual. Podrían producirse lesiones personales y/o daños al producto si se utiliza fuera de su propósito previsto y/o si ha sido modificado respecto a su diseño original. El vendedor no asume ninguna responsabilidad por daños/lesiones causados por un montaje incorrecto o uso inadecuado.
- Evite la exposición prolongada a ambientes húmedos para prevenir la aparición de moho.
- Mantenga el producto alejado de fuentes de calor y altas temperaturas. No exponga el producto a la luz solar directa.
- No coloque objetos calientes sobre la superficie del producto.
- Si después de desembalar encuentra piezas defectuosas o faltantes, interrumpa inmediatamente el montaje y contáctenos.
- Ensamble el artículo en una superficie espaciosa y no coloque el producto desembalado directamente en el suelo para evitar daños.
- No se pare ni se sienta sobre los tableros de madera.
- Use guantes durante el proceso de montaje y/o desmontaje para evitar cortes por bordes afilados.
- Empareje las piezas y herrajes correspondientes según el número de pieza indicado en el manual.
- Si la pieza no coincide con el herraje, verifique la pieza como se especifica en este manual.
- Durante el montaje, alinee primero todos los tornillos sin apretar en los agujeros pretaladrados correspondientes y luego apriételes uno por uno.
- Verifique periódicamente la firmeza de los tornillos durante el uso del producto. Si es necesario, apriételes nuevamente para garantizar la estabilidad estructural.
- Si derrama accidentalmente agua u otro líquido sobre la superficie, séquelo inmediatamente con un paño seco.
- Mantenga el producto alejado de objetos puntiagudos, cortantes y sustancias corrosivas para evitar daños.
- Coloque el artículo sobre una superficie plana y estable durante su uso.

Advertencias

- Durante el montaje, mantenga todas las piezas pequeñas fuera del alcance de los niños. La ingestión o inhalación puede ser fatal.
- Los niños no deben trepar ni jugar sobre el producto para evitar que el mueble se vuelque y cause lesiones graves.
- Para evitar riesgos potenciales de asfixia, mantenga todas las piezas y embalajes (film, bolsas de plástico, espuma, etc.) fuera del alcance de bebés y niños.
- Mantenga objetos afilados y sustancias corrosivas lejos del producto para evitar daños o lesiones.
- No sacuda ni mueva bruscamente el producto durante su uso para evitar que se voltee.

Parts List (EN)/Teile Liste (DE)

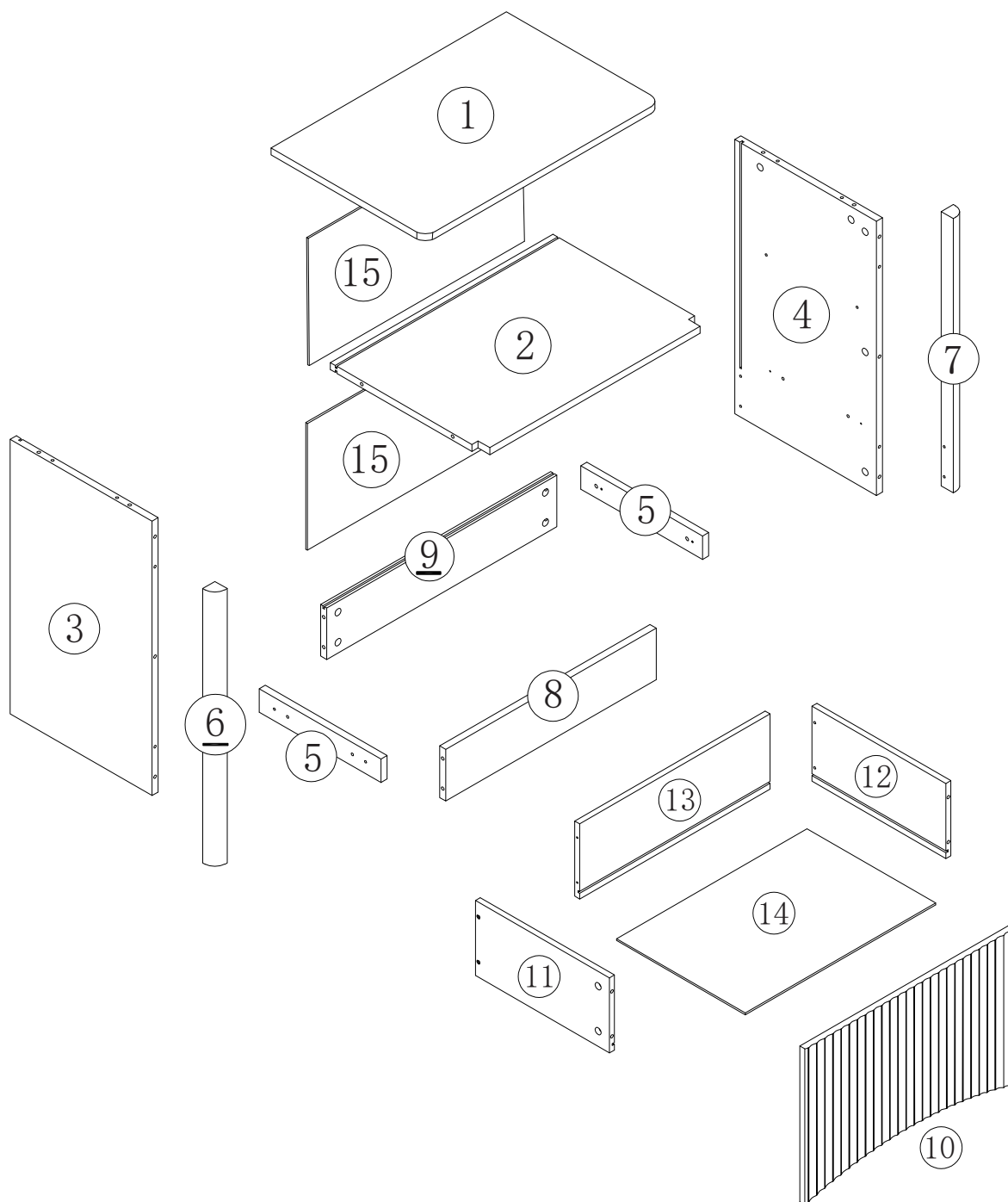

Instructions For Fastening CAM-BOLT and CAM-LOCK



CAM-BOLT



CAM-LOCK

Tools Required

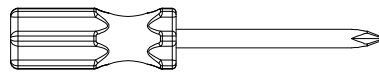

INSERTING AND TIGHTENING CAM-BOLT

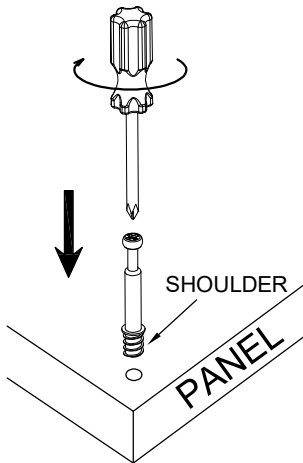

Place Cam-bolt on pre-drilled hole and screw in vertically

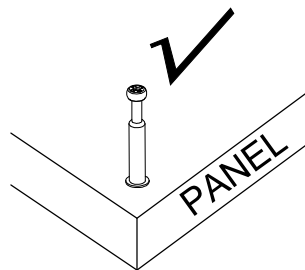

Shoulder is flushed (on the same level) with the panel

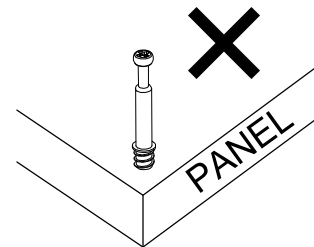

Shoulder is above the panel

Place Cam-bolt on the designated pre-drilled holes on the panel. Use a Phillips Screwdriver to screw-in Cam-bolt vertically until shoulder is flushed (on the same level) with panel.

INSERTING CAM-LOCK

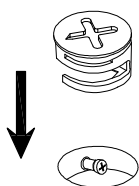

Insert Cam-lock with arrow align to Cam-bolt head

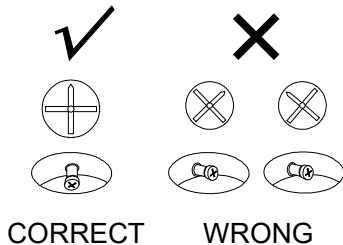

CORRECT

WRONG

TIGHTENING CAM-LOCK

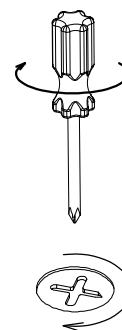

Align the arrow on the Cam-lock to the Cam-bolt head and insert the Cam-lock. Ensure Cam-lock is fully inserted.

Use a Flat-head Screwdriver to turn Camlock clockwise so it locks onto the head of the Cam-bolt. Turn until it is snug (about 3/4ths of a turn) -- over-tightening could damage Cam-lock or/and Cam-bolt.



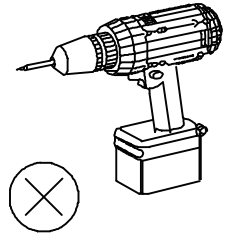
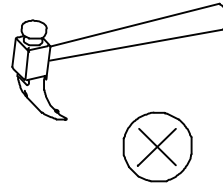
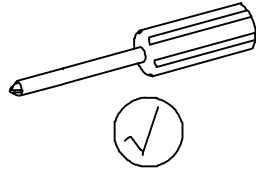
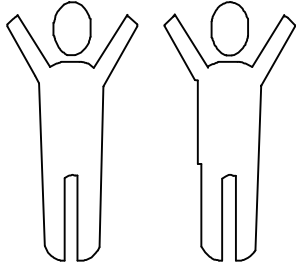

Parts List (EN) / Teile Liste (DE)

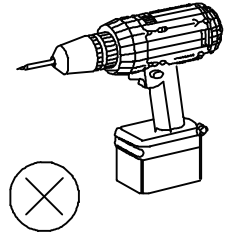
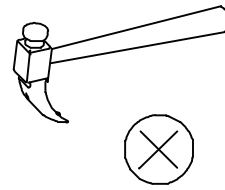
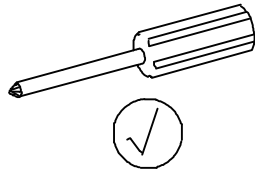
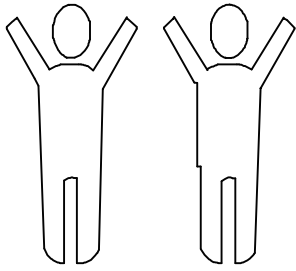

<p>①</p> <p>1PC</p>	<p>②</p> <p>1PC</p>	<p>③</p> <p>1PC</p>	<p>④</p> <p>1PC</p>
<p>⑤</p> <p>2PCS</p>	<p>⑥</p> <p>1PC</p>	<p>⑦</p> <p>1PC</p>	<p>⑧</p> <p>1PC</p>
<p>⑨</p> <p>1PC</p>	<p>⑩</p> <p>1PC</p>	<p>⑪</p> <p>1PC</p>	<p>⑫</p> <p>1PC</p>
<p>⑬</p> <p>1PC</p>	<p>⑭</p> <p>1PC</p>	<p>⑮</p> <p>2PCS</p>	

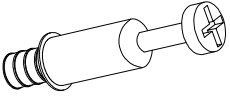
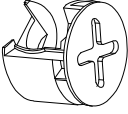
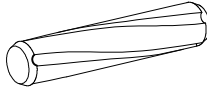
Parts List (EN)/Teile Liste (DE)

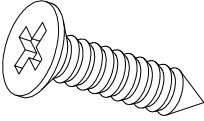
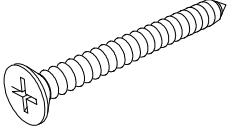
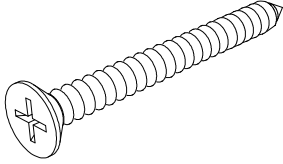
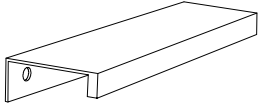
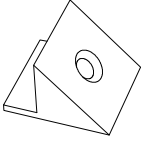
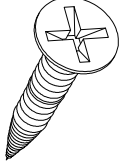
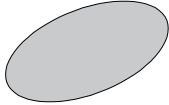
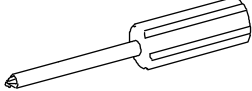
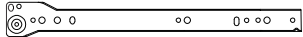
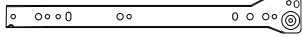

<p>A</p>  <p>Ø6*40mm</p> <p>26+2PCS</p>	<p>B</p>  <p>Ø15*9.5mm</p> <p>26+2PCS</p>	<p>C</p>  <p>Ø8*30mm</p> <p>8+1PCS</p>	<p>D</p>  <p>Ø8*20mm</p> <p>4+1PCS</p>
<p>E</p>  <p>M3.5*12mm</p> <p>10+1PC</p>	<p>F</p>  <p>M3.5*25mm</p> <p>4+1PCS</p>	<p>G</p>  <p>M3.5*30mm</p> <p>4+1PCS</p>	<p>H</p>  <p>1PC</p>
<p>J (J1)</p>  <p>8+1PCS</p> <p>(J2)</p>  <p>M3*14mm</p> <p>8+1PCS</p>	<p>K</p>  <p>16+1PC</p>	<p>OR</p>  <p>1PC</p>	
<p>CL  1PC L=300mm</p> <p>CR  1PC L=300mm</p>		<p>DL  1PC L=300mm</p> <p>DR  1PC L=300mm</p> <p>Note: The other holes of the pulley are for self-flexible adjustment, maintenance and replacement</p>	

Parts List (EN) / Teile Liste (DE)

Step 01

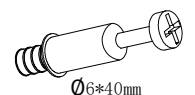
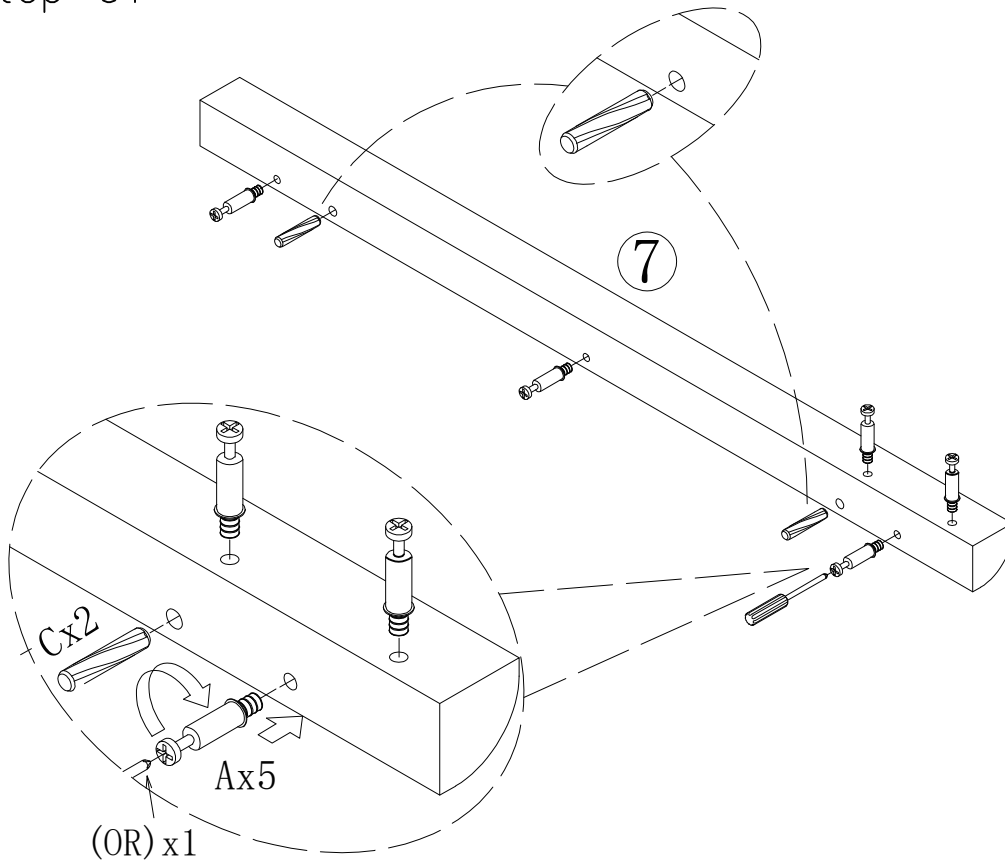

Ø6*40mm

Ax5



Ø8*30mm

Cx2

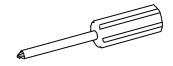

(OR) x1

Step 02

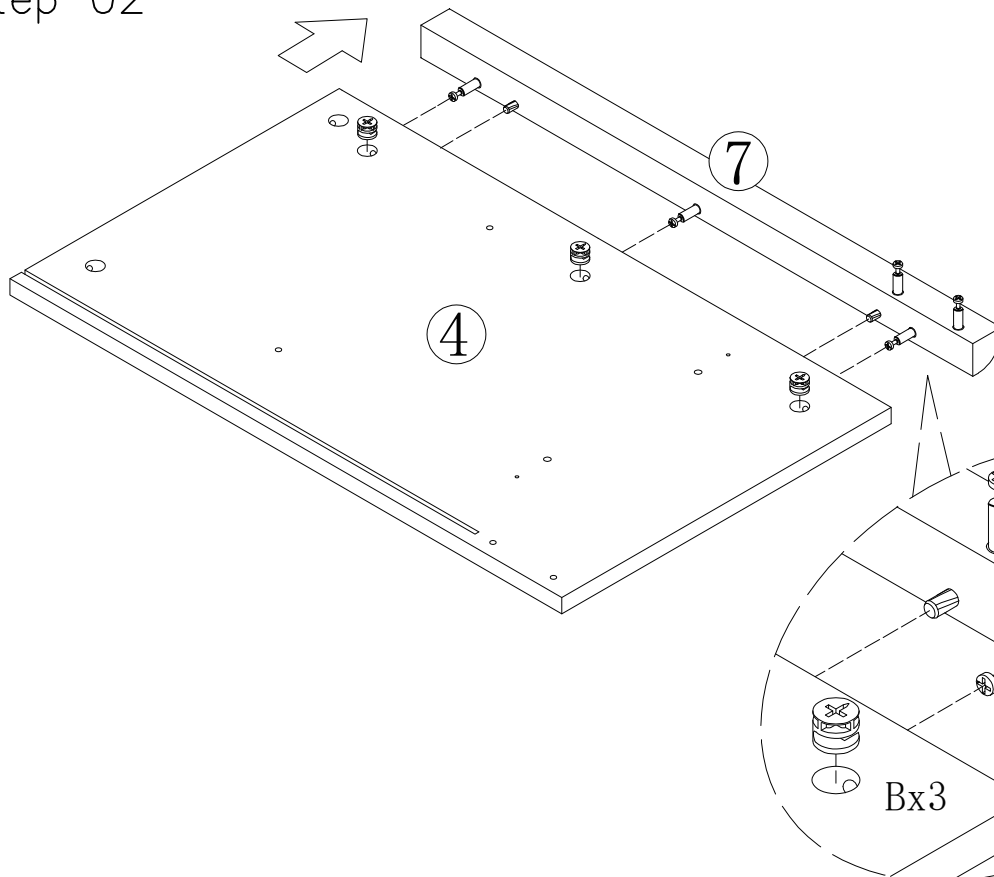

Ø15*9.5mm

Bx3

Parts List (EN)/Teile Liste (DE)

Step 03

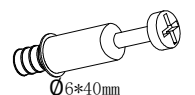
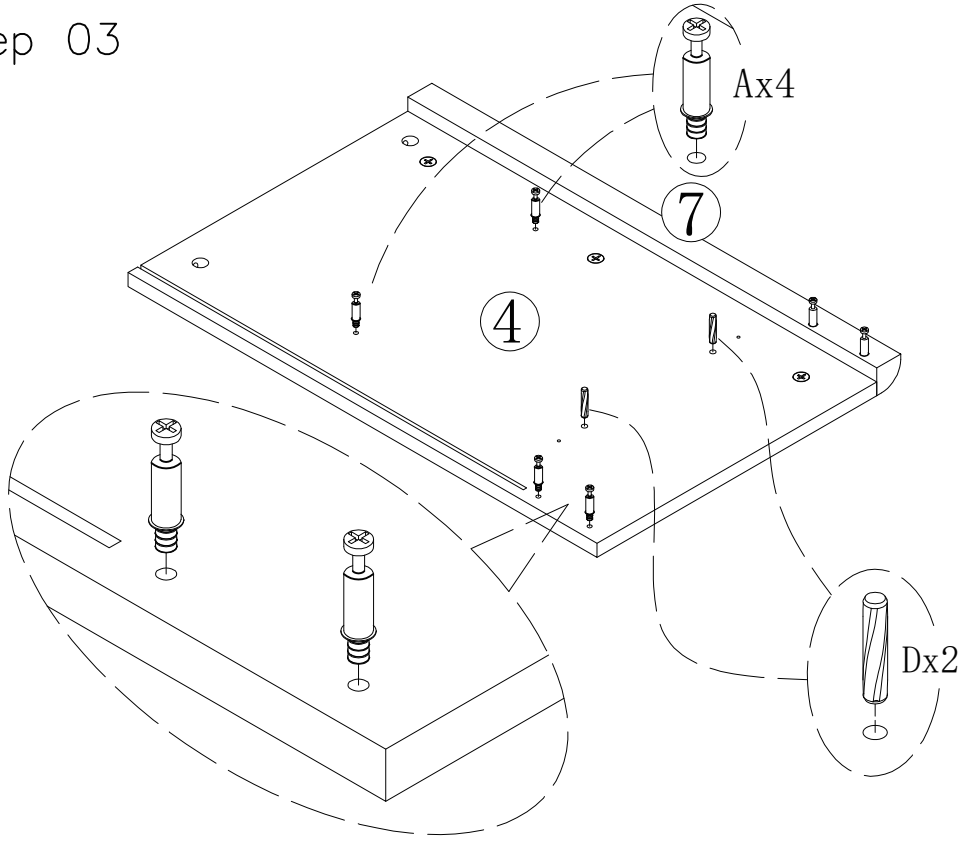

Ø6*40mm

Ax4



Ø8*20mm

Dx2

Step 04



Before installation, it is necessary to confirm the installation direction of the components ⑤

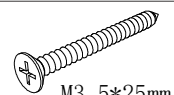
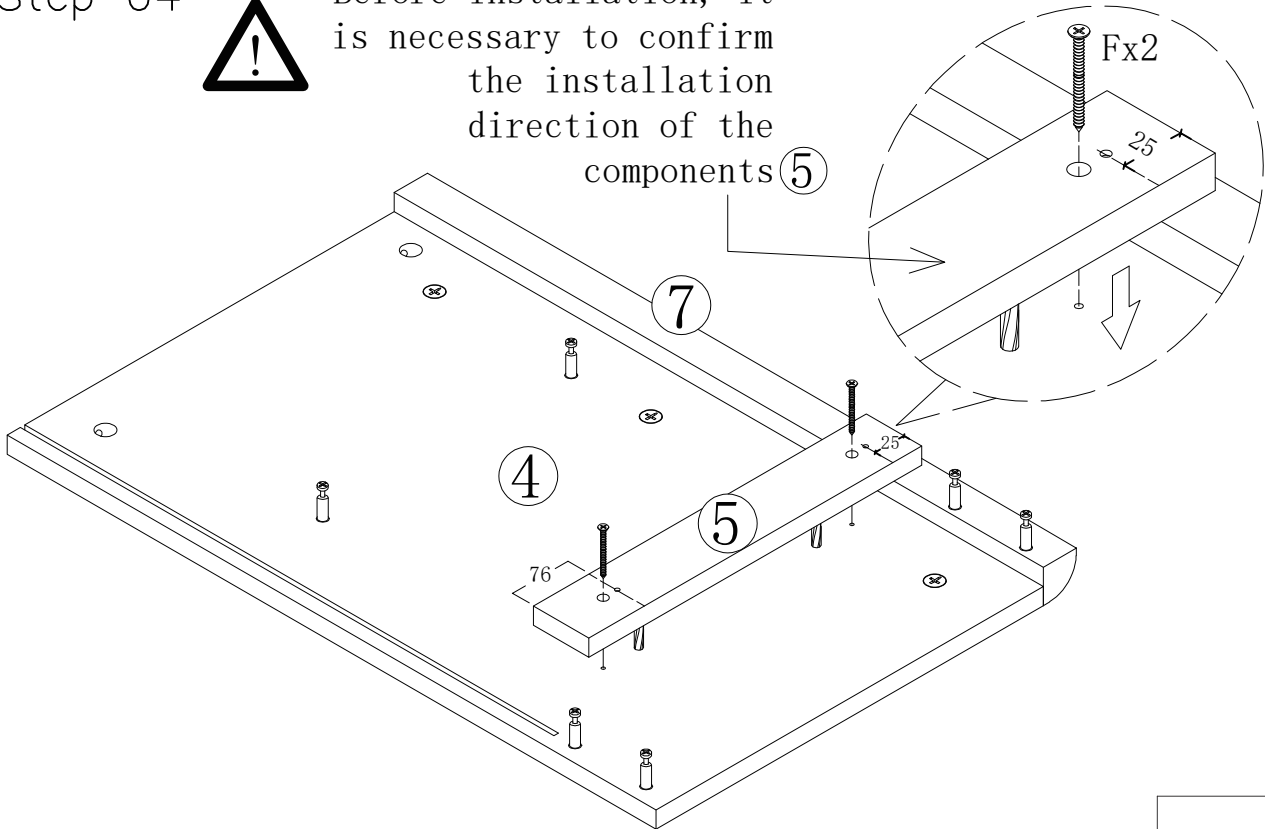

M3.5*25mm

Fx2

Parts List (EN) / Teile Liste (DE)

Step 05



Fasten fitting "E" as tight as possible to avoid failure in subsequent drawer installation.

Pay attention to the corresponding holes of the screws

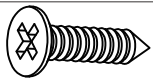
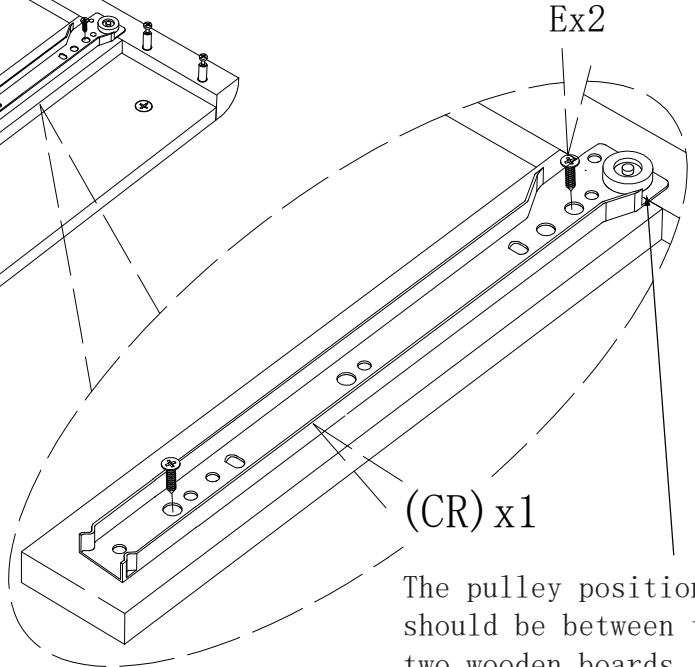
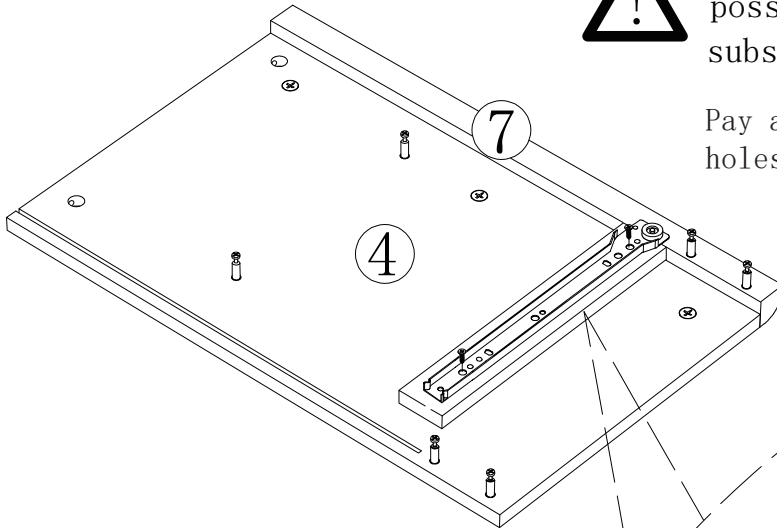

M3.5*12mm

Ex2



(CR) x1

L=300mm

The pulley position should be between the two wooden boards

Step 06



Ø15*9.5mm

Bx2

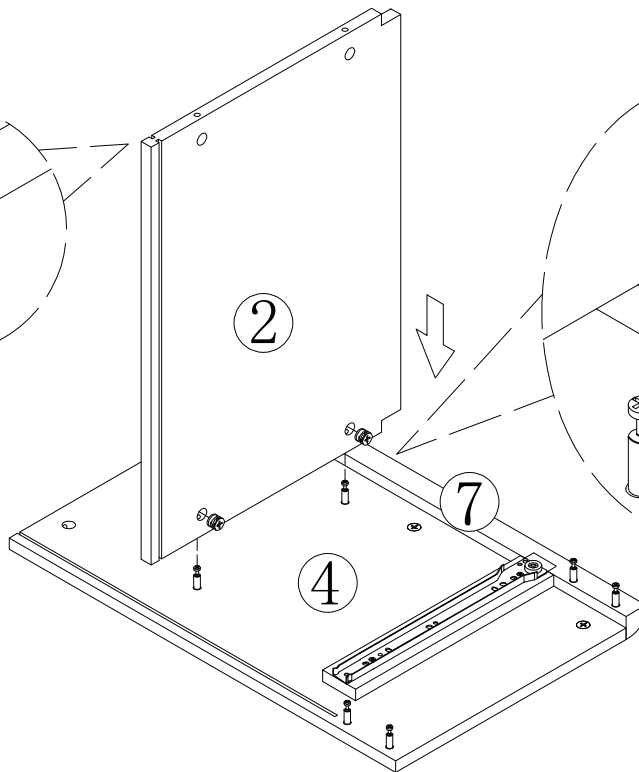
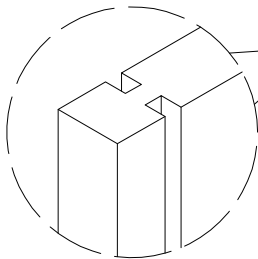

Pay attention to the direction of the notch. If you install it incorrectly in this step, step 15 will fail to install.

Parts List (EN) / Teile Liste (DE)

Step 07



Ø15*9.5mm

Bx2

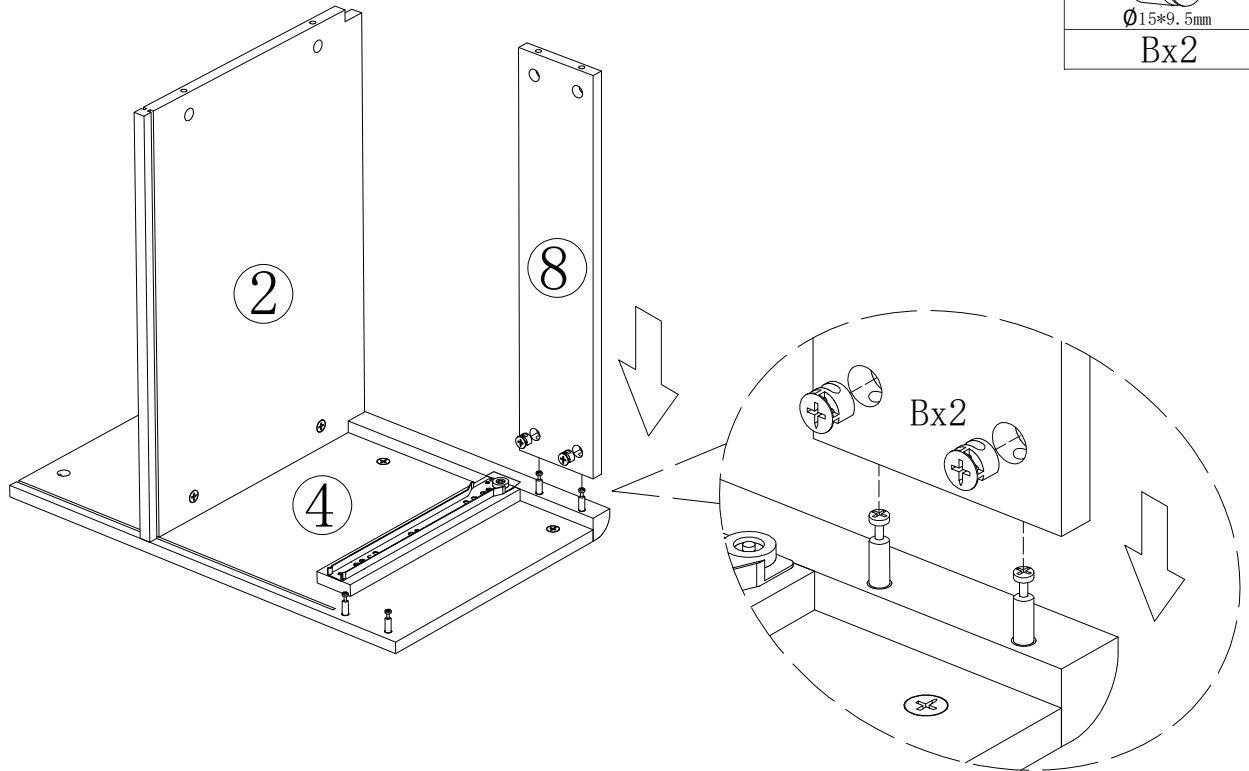

Step 08



Ø15*9.5mm

Bx2



Pay attention to the orientation of the grooves on the wooden board

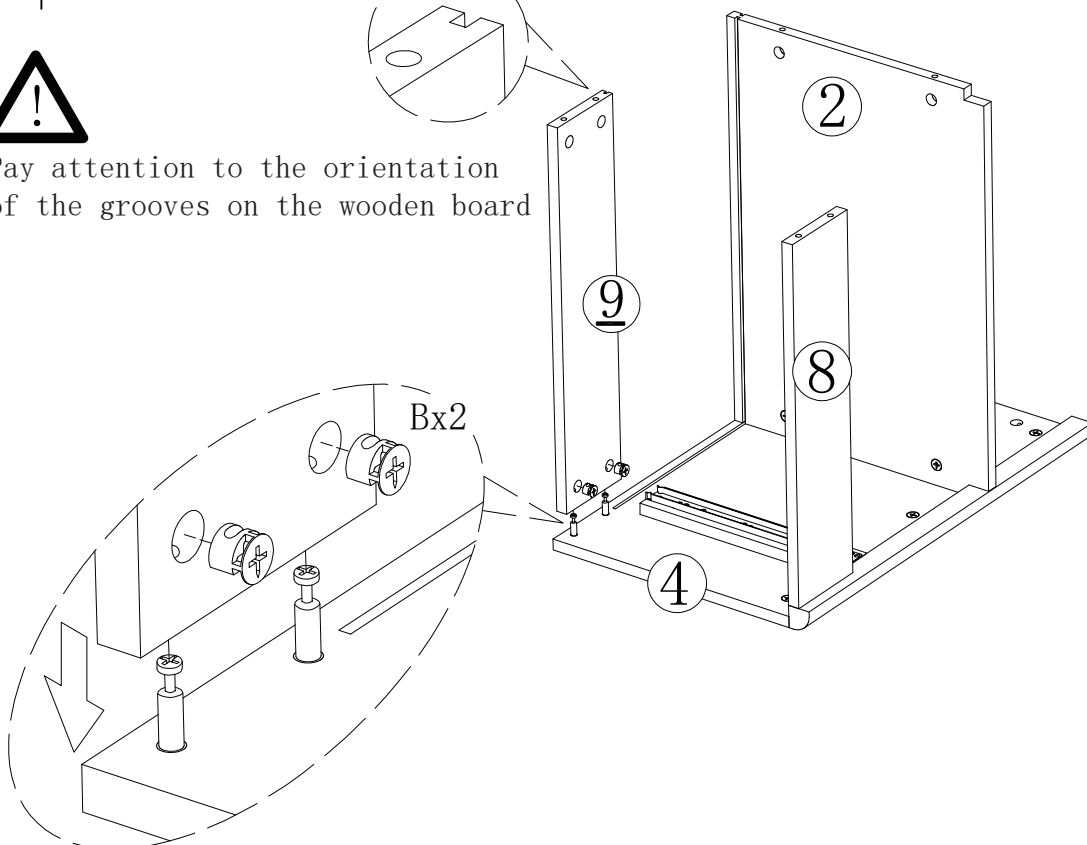
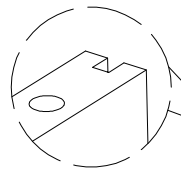

Parts List (EN) / Teile Liste (DE)

Step 09

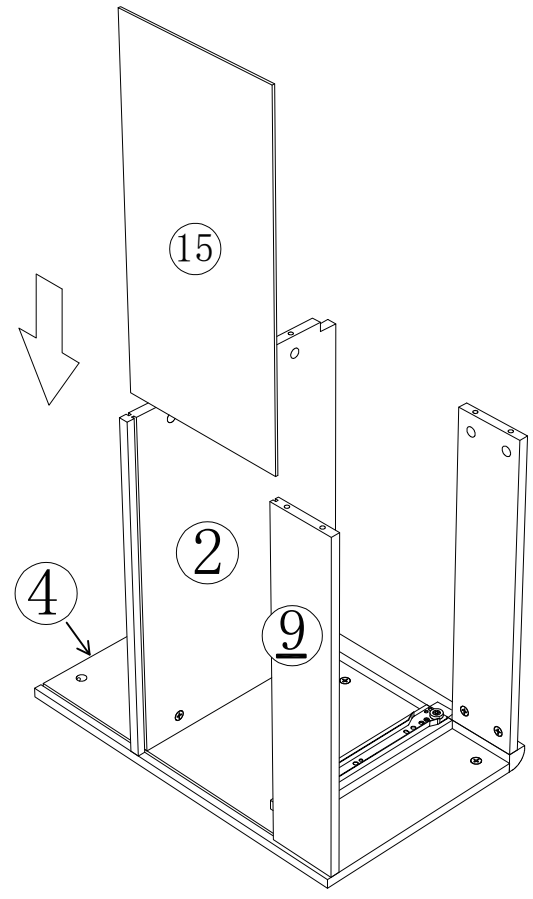

Step 10

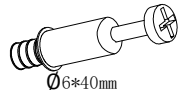
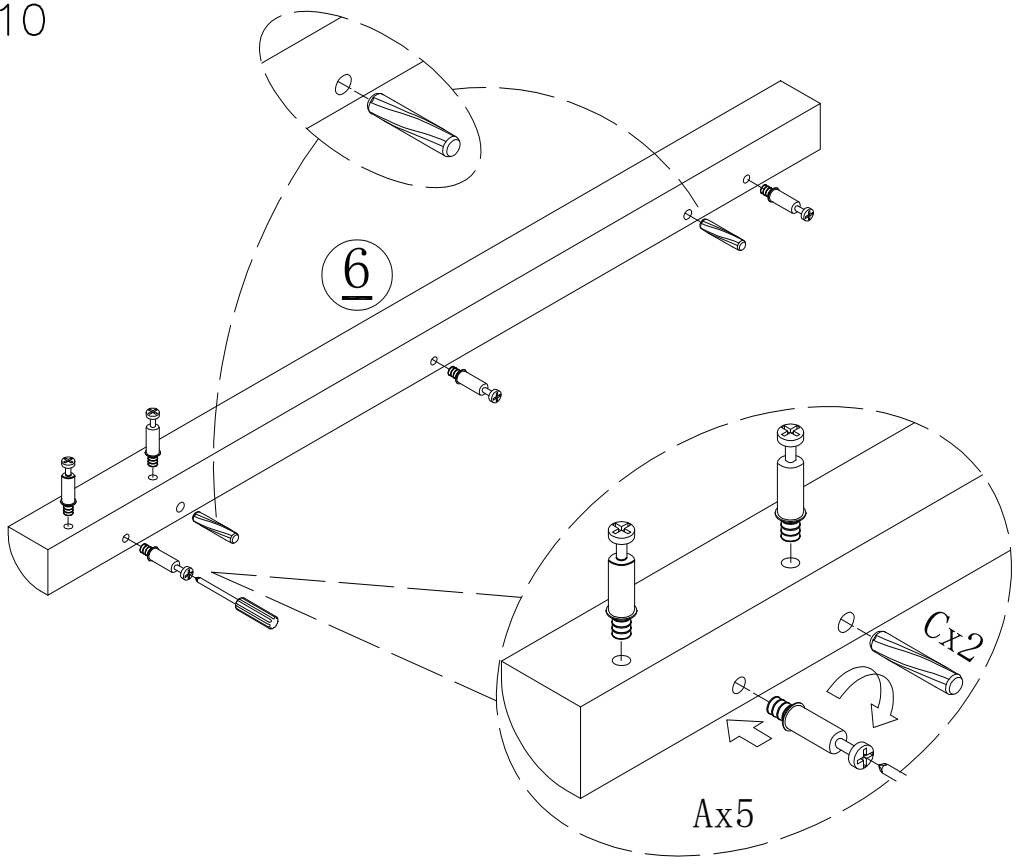

Ø6*40mm

Ax5



Ø8*30mm

Cx2

Parts List (EN) / Teile Liste (DE)

Step 11



Ø15*9.5mm

Bx3

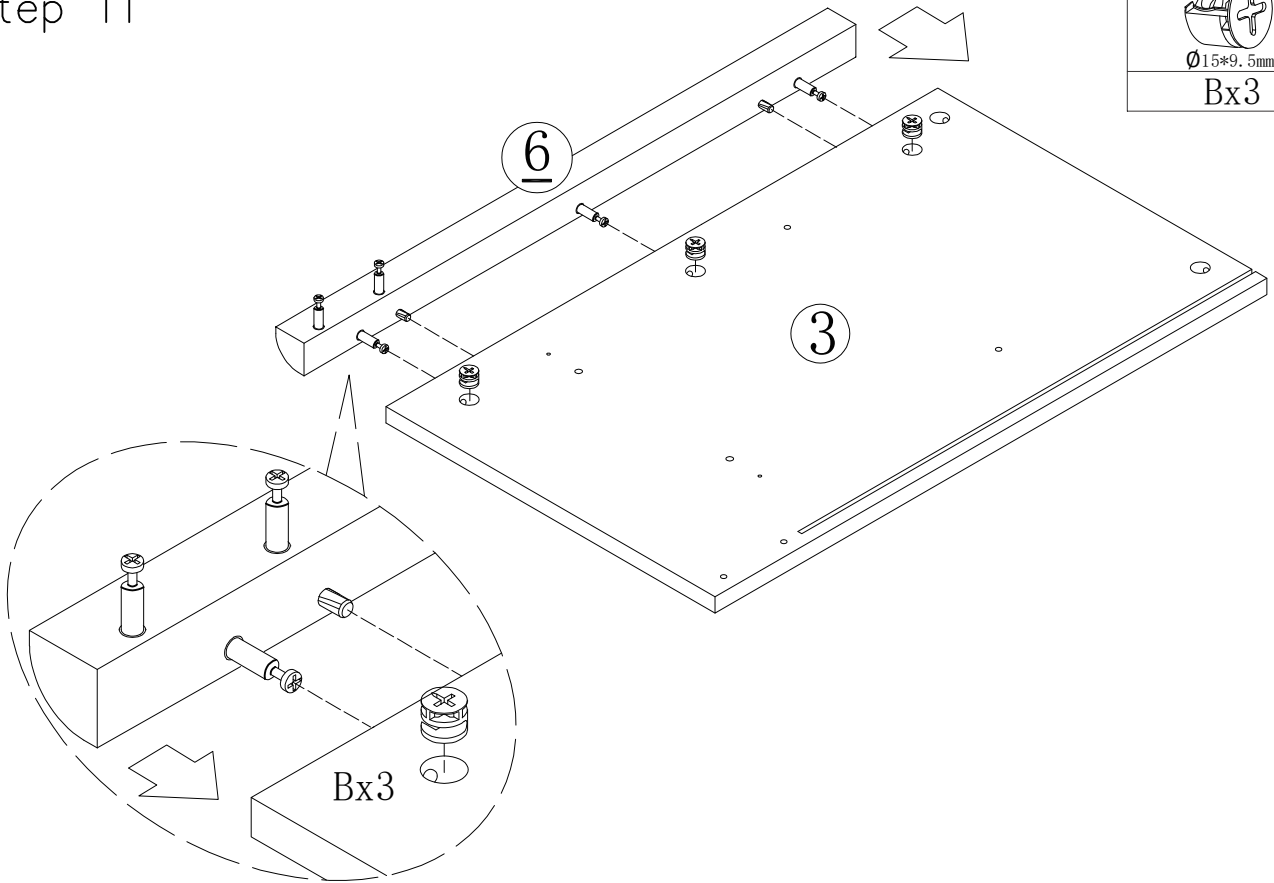

Step 12

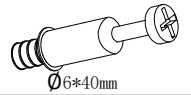

Ø6*40mm

Ax4



Ø8*20mm

Dx2

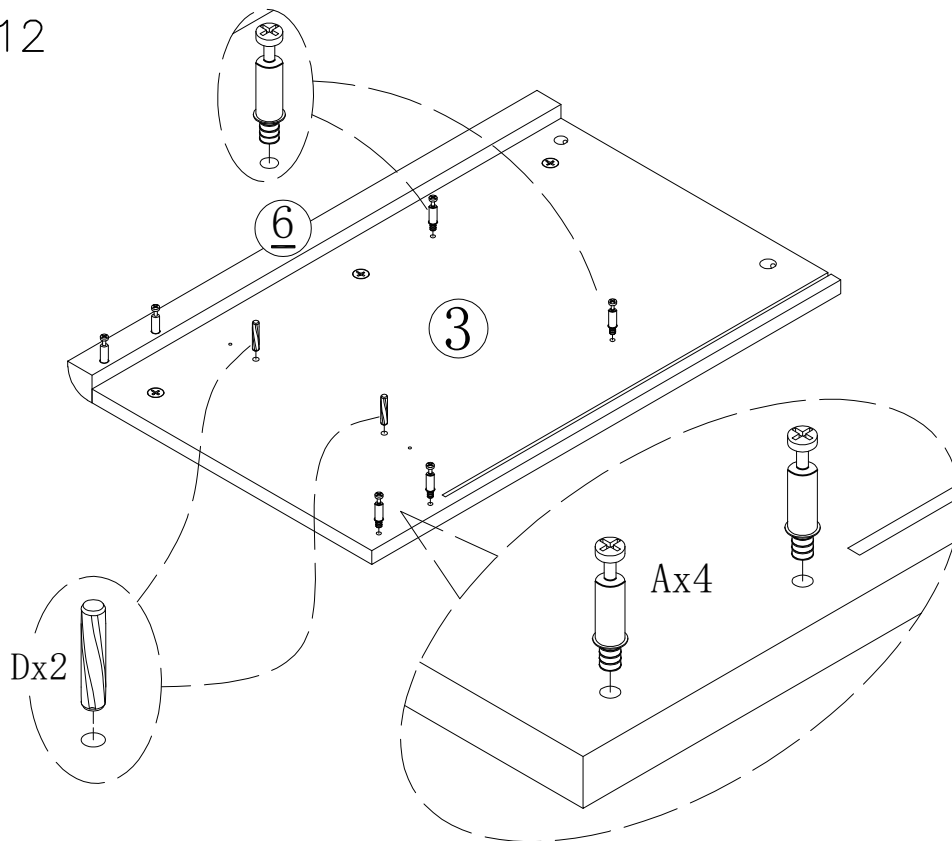

Parts List (EN)/Teile Liste(DE)

Step 13



Before installation, it is necessary to confirm the installation direction of the components ⑤

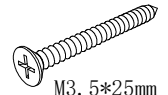

M3.5*25mm

Fx2

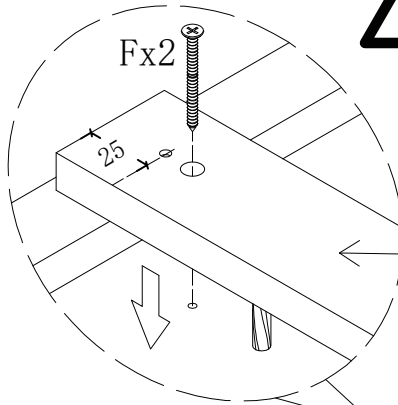

Fx2

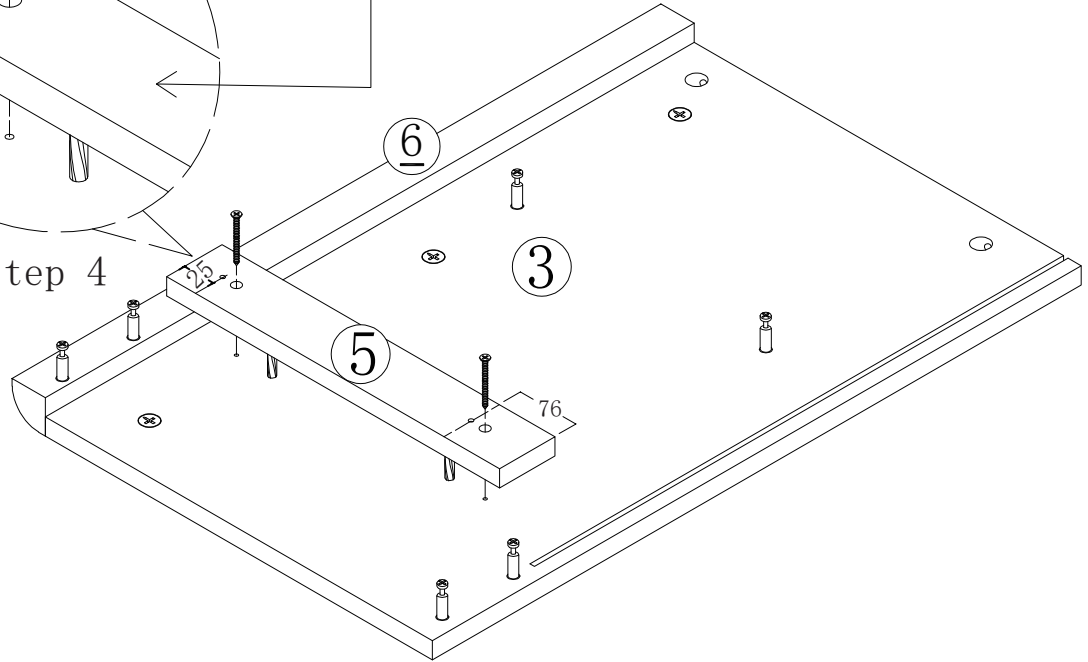

Refer to Step 4

Step 14



Fasten fitting "E" as tight as possible to avoid failure in subsequent drawer installation.

Refer to Step 5

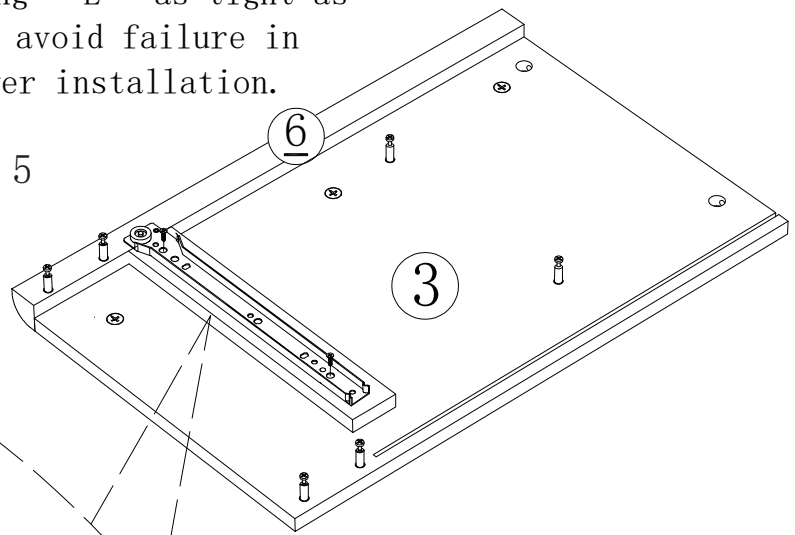

Ex2

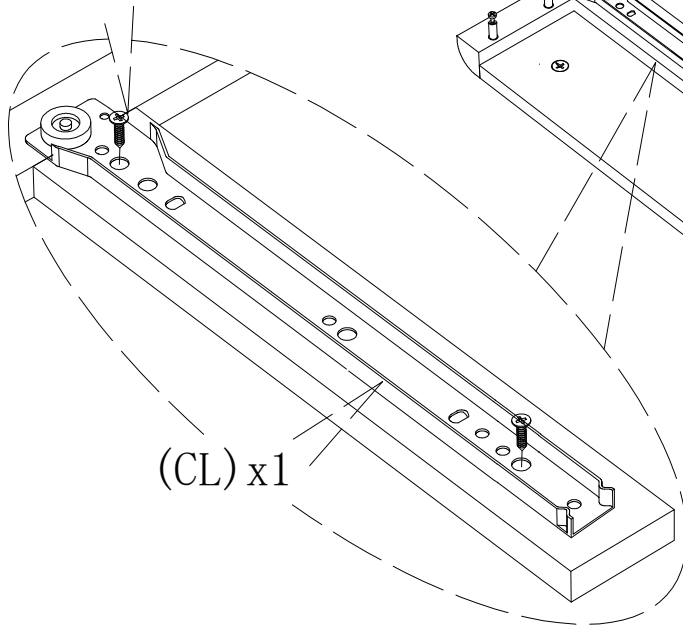

(CL) x1

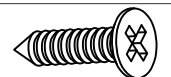

M3.5*12mm

Ex2

L=300mm



(CL) x1

Parts List (EN) / Teile Liste (DE)

Step 15



Ø15*9.5mm

Bx6

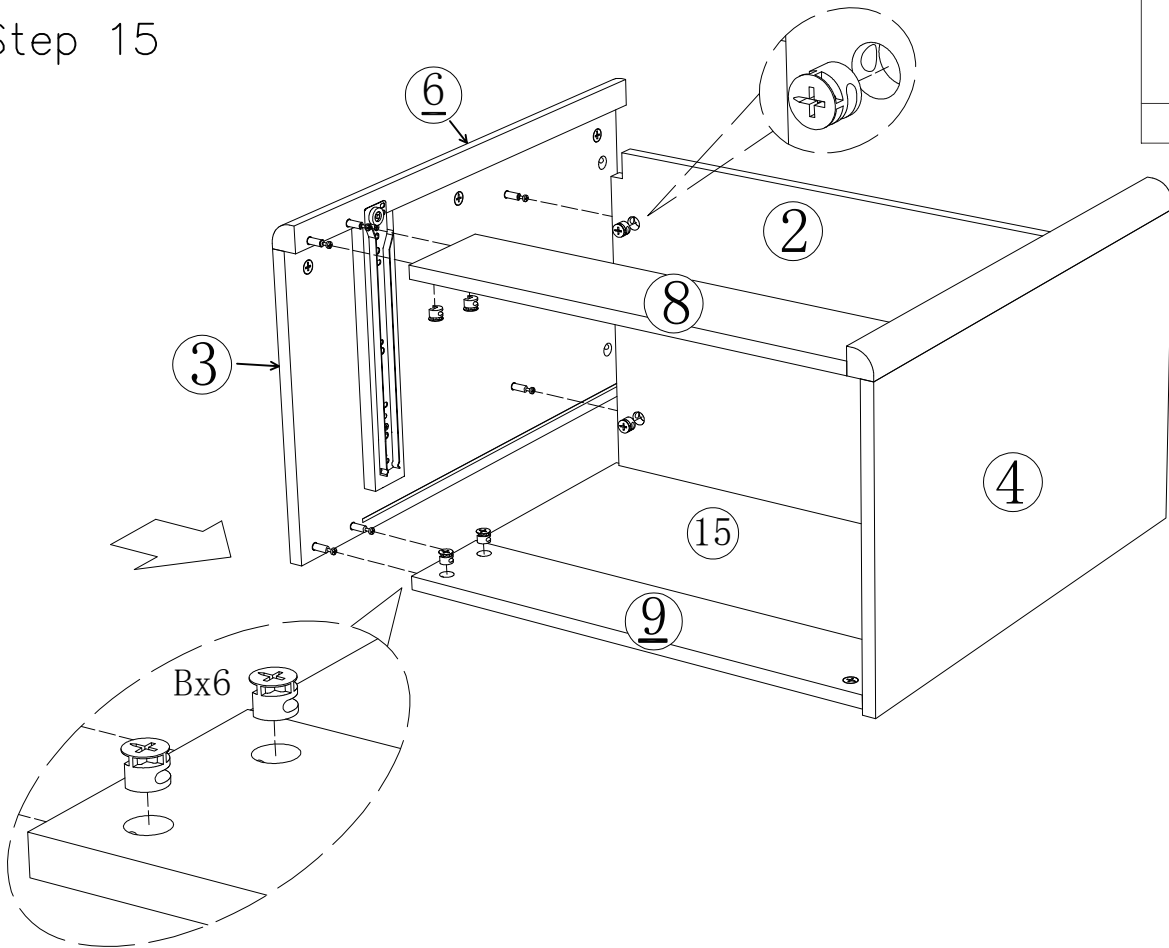

Step 16

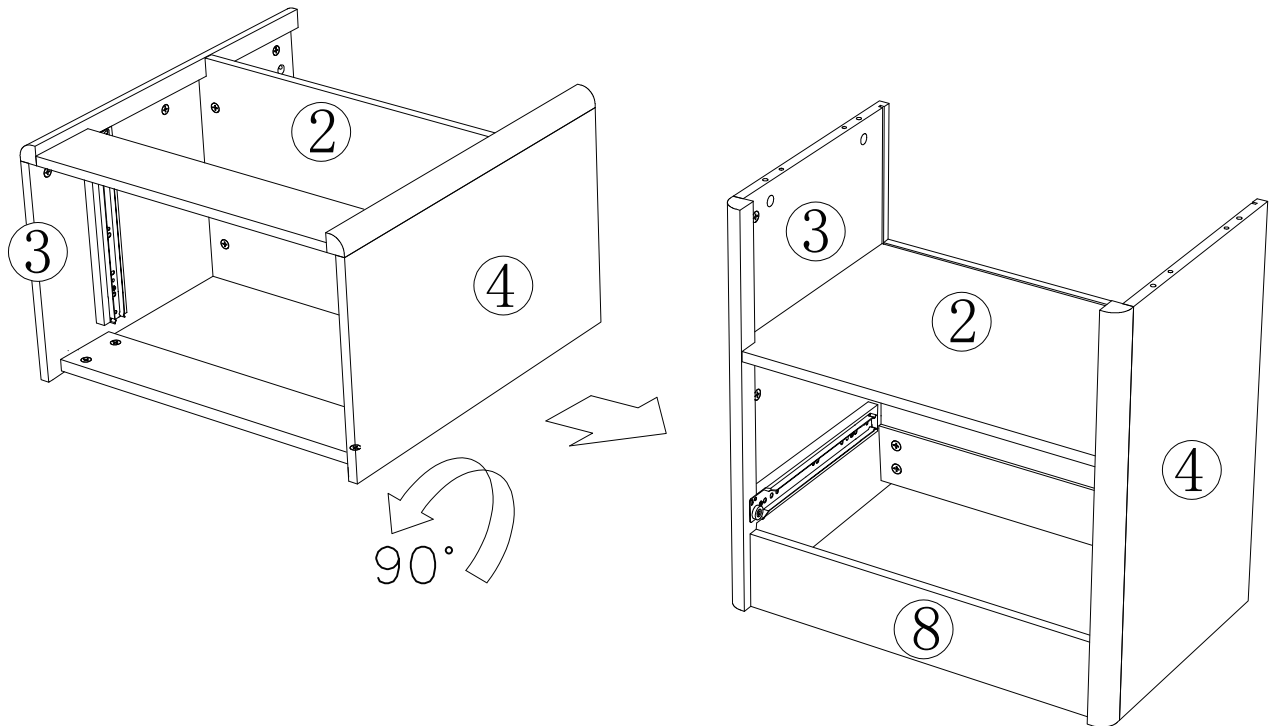

Parts List (EN) / Teile Liste (DE)

Step 17

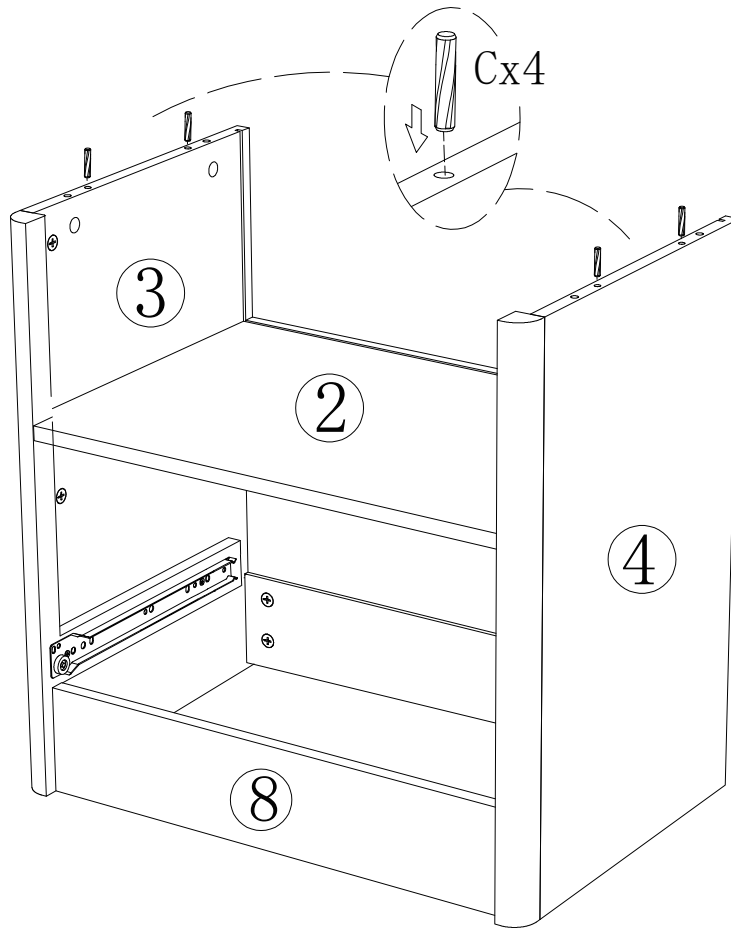

Ø8*30mm

Cx4

Step 18

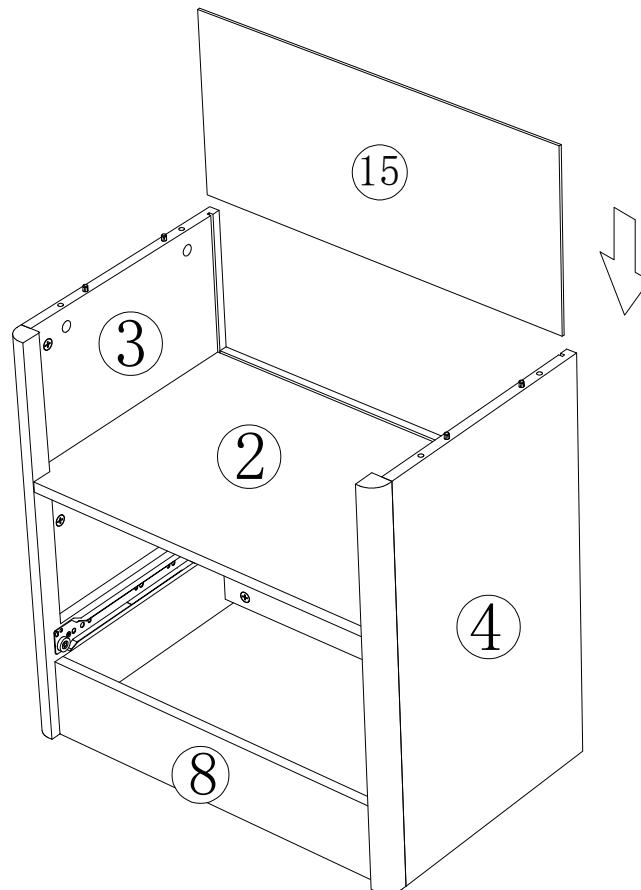

Parts List (EN) / Teile Liste (DE)

Step 19

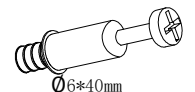

Ø6*40mm

Ax4

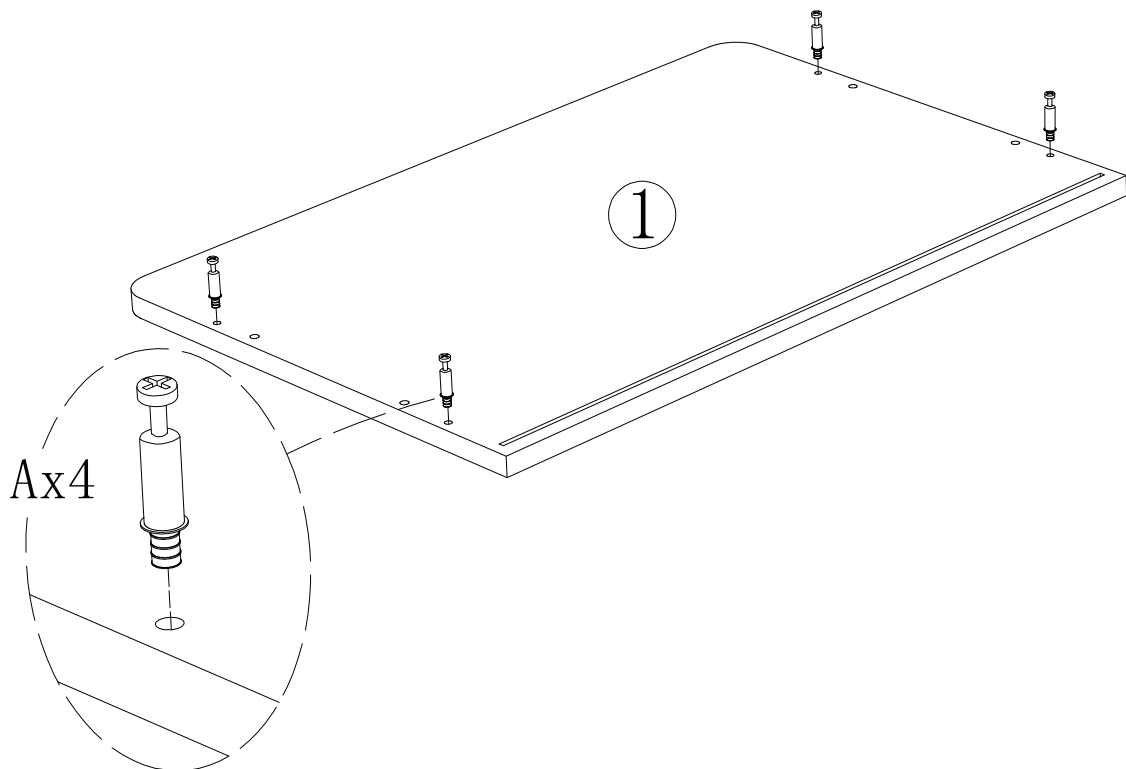

Step 20



Ø15*9.5mm

Bx4

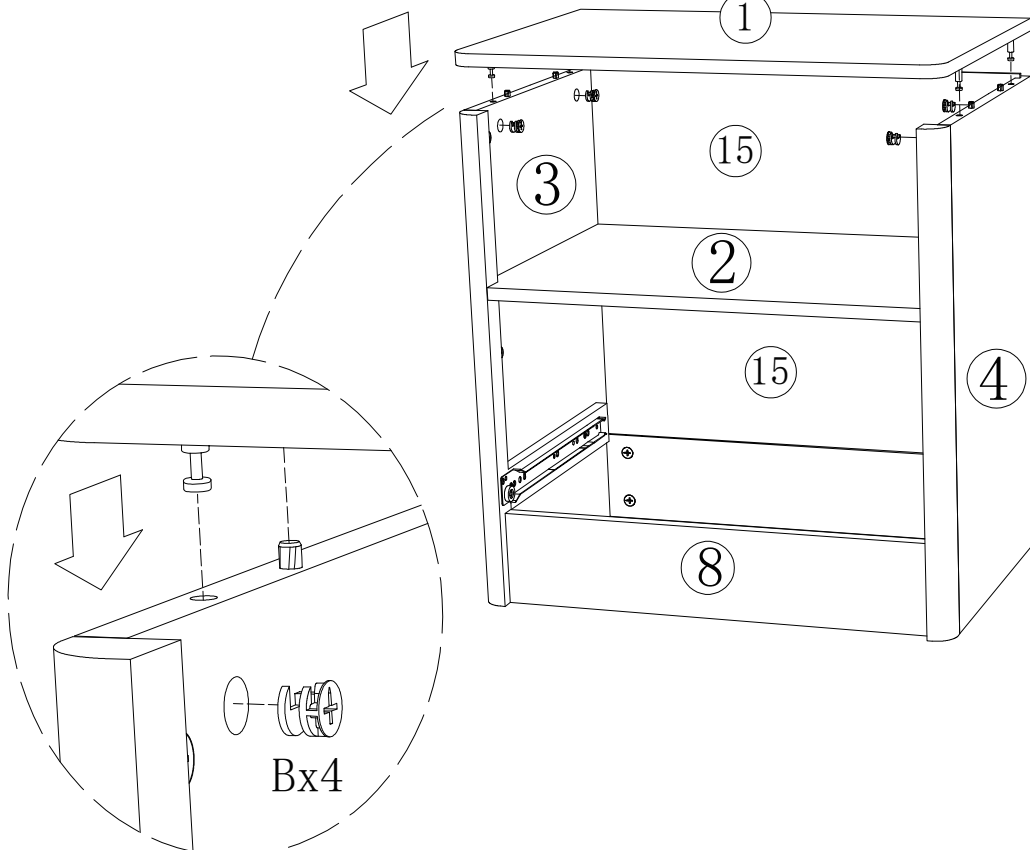

Parts List (EN) / Teile Liste (DE)

Step 21

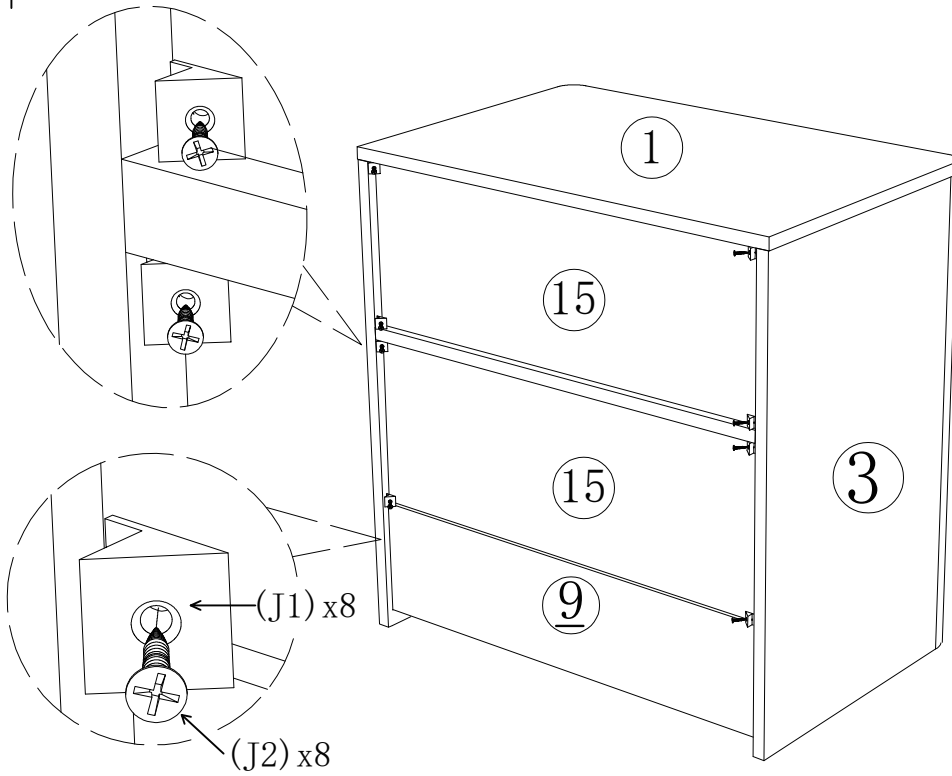

(J1) x8

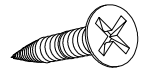

M3*14mm

(J2) x8

Step 22

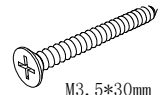
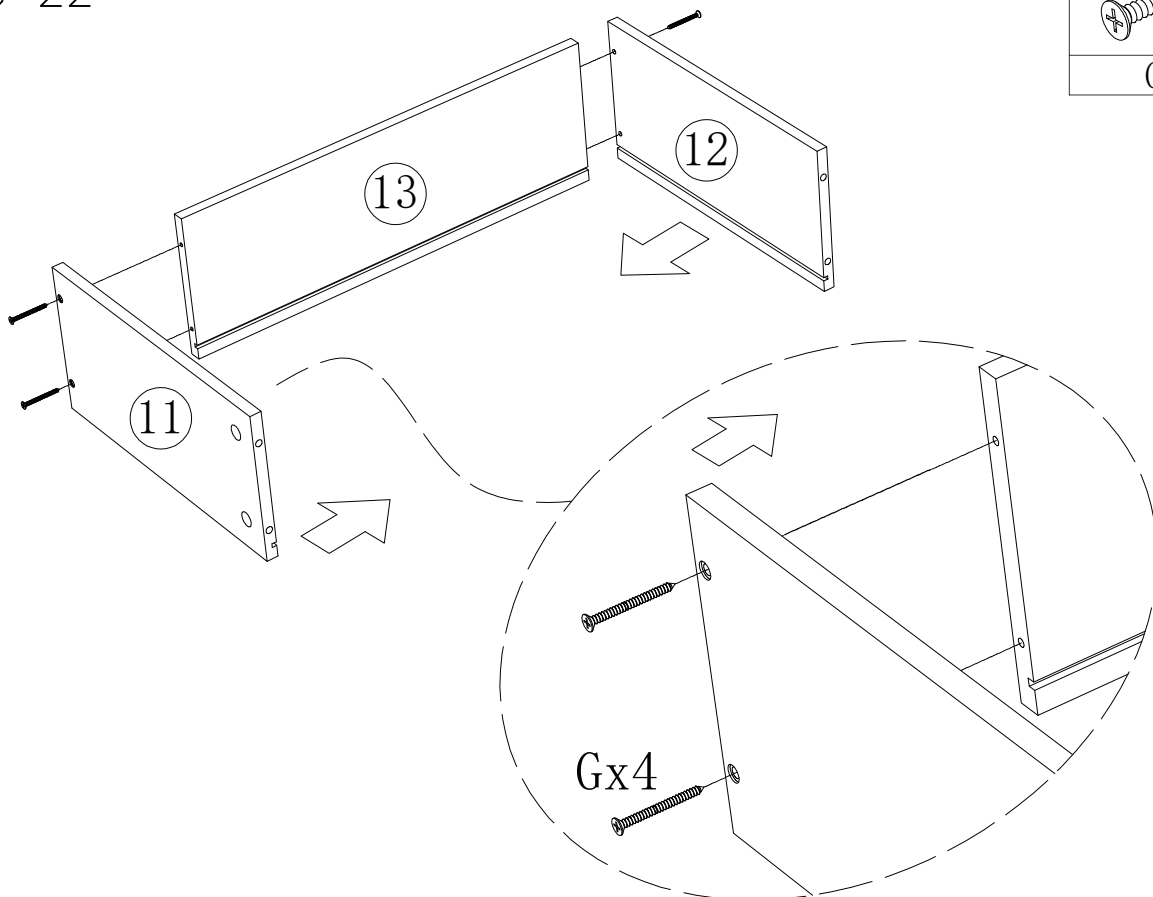

M3.5*30mm

Gx4

Parts List (EN) / Teile Liste (DE)

Step 23

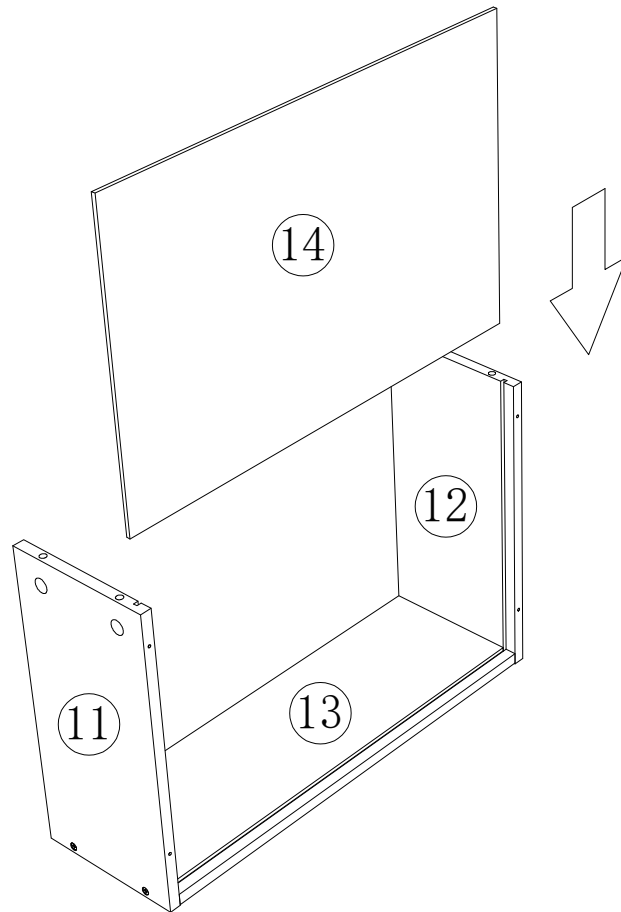

Step 24

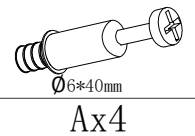
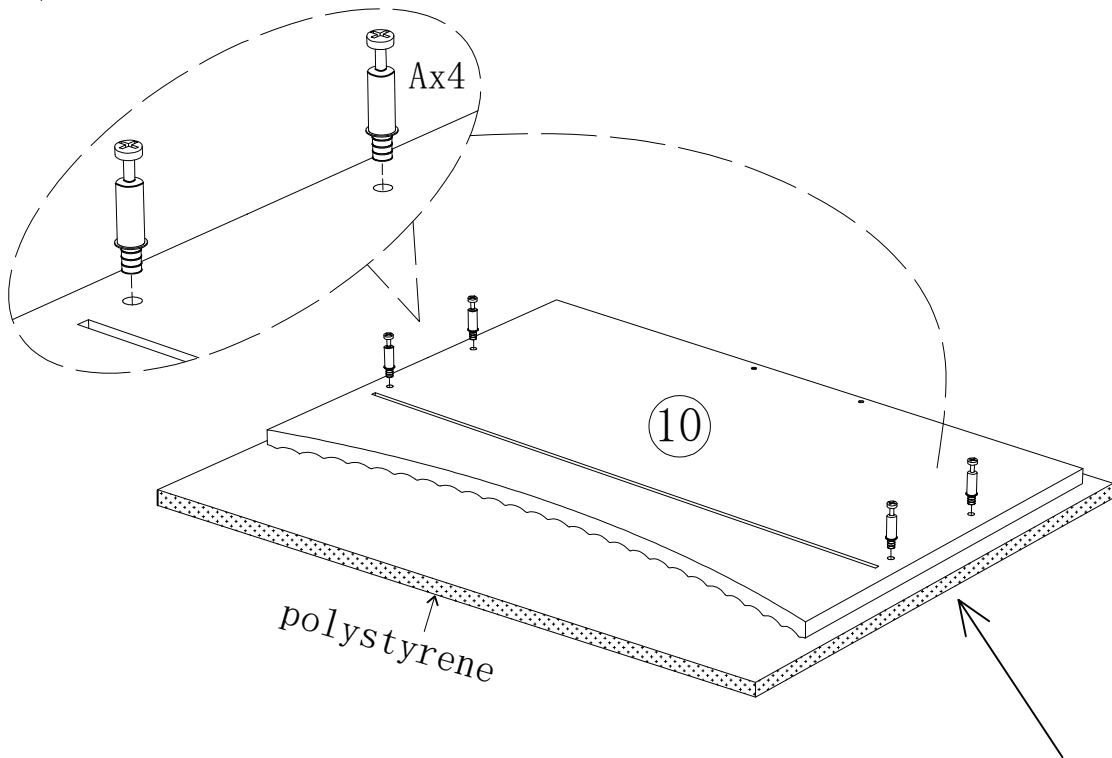

Please lay a layer of polystyrene before installation to protect the components from damage

Parts List (EN) / Teile Liste (DE)

Step 25



Ø15*9.5mm

Bx4

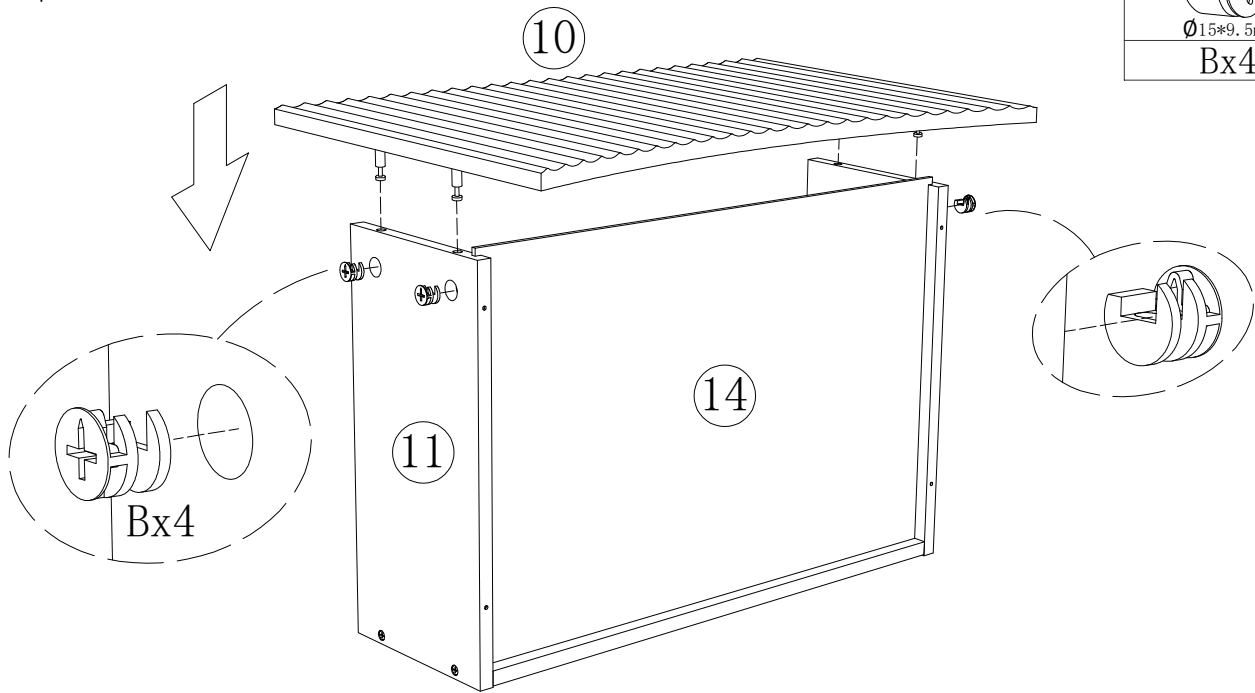

Note that the concave side of the wooden board should face down

Step 26

L=300mm

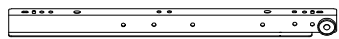

(DR) x1



(DL) x1



M3.5*12mm

Ex4



Pay attention to the corresponding holes of the screws

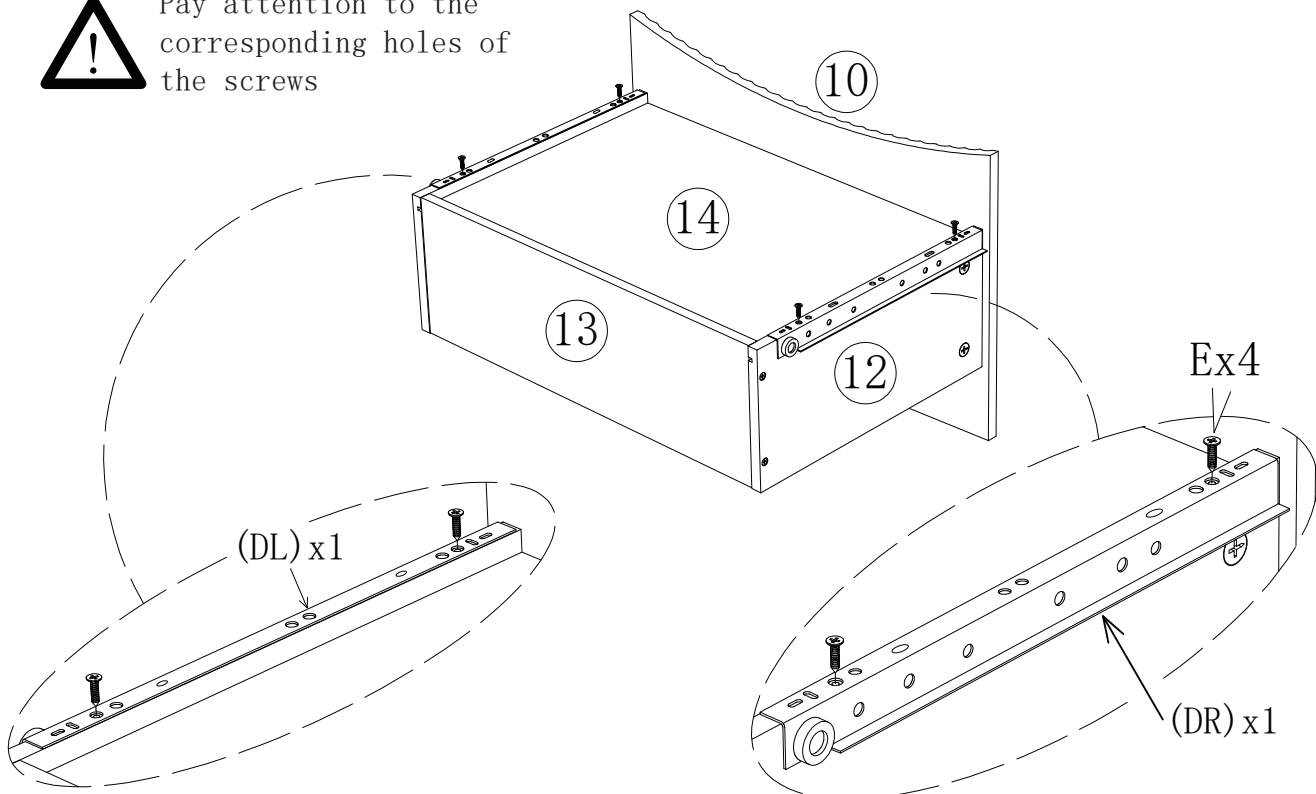

Parts List (EN) / Teile Liste (DE)

Step 27

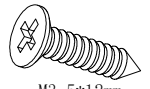
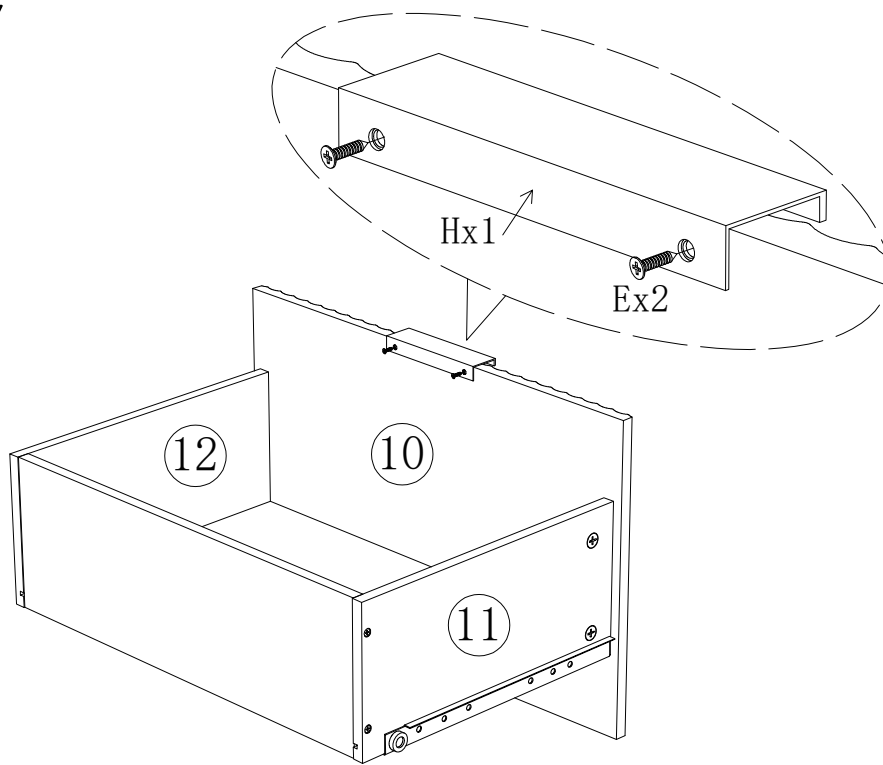

M3.5*12mm

Ex2

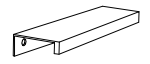

Hx1

Step 28

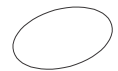
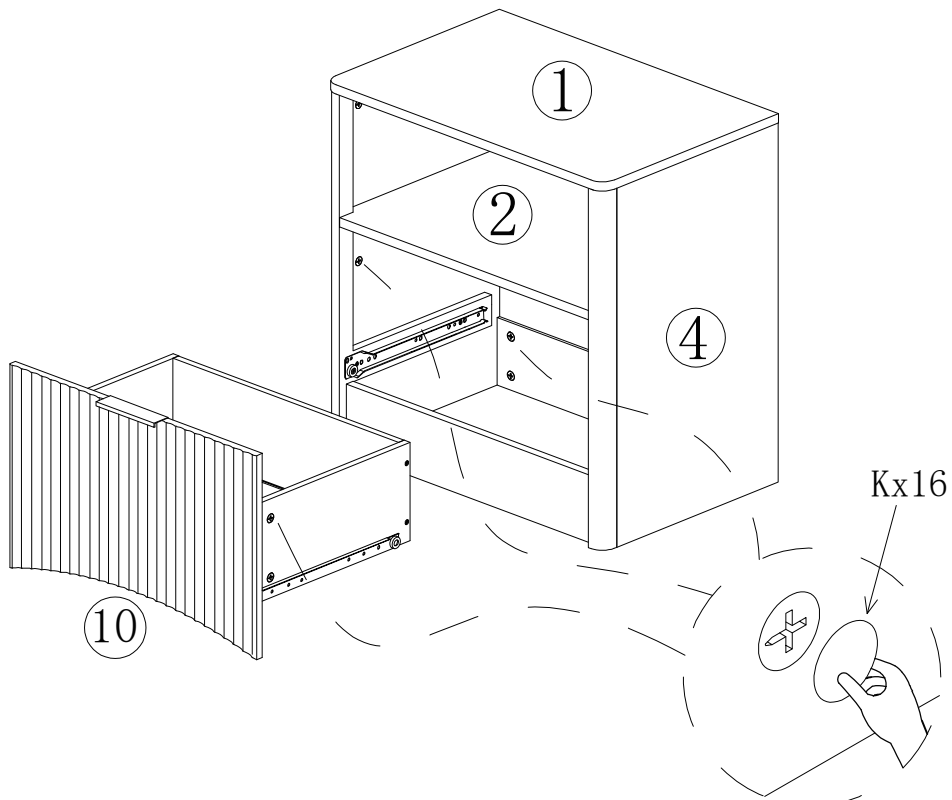

Kx16

Parts List (EN) / Teile Liste (DE)

Step 29

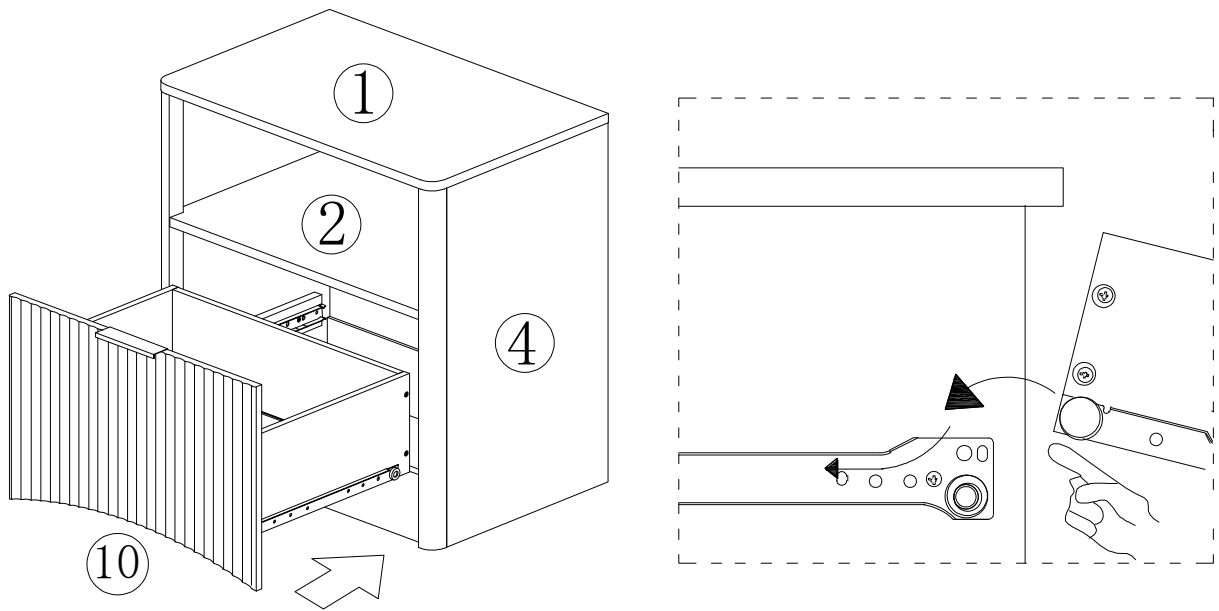

Step 30

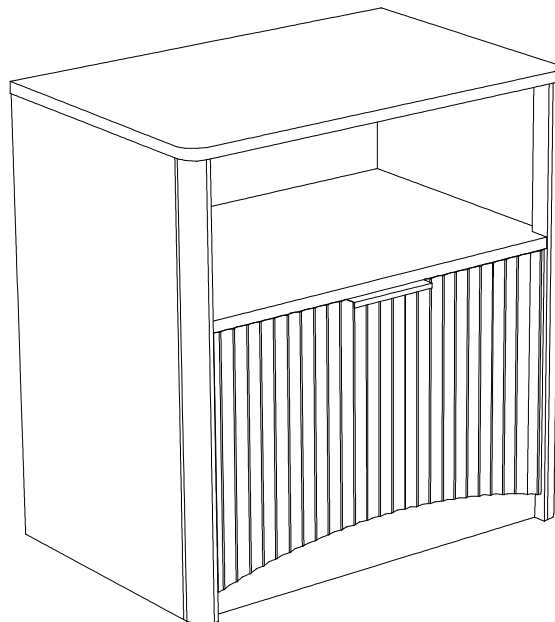

— Final —