

# ASSEMBLY INSTRUCTION

WF310000/WF310001

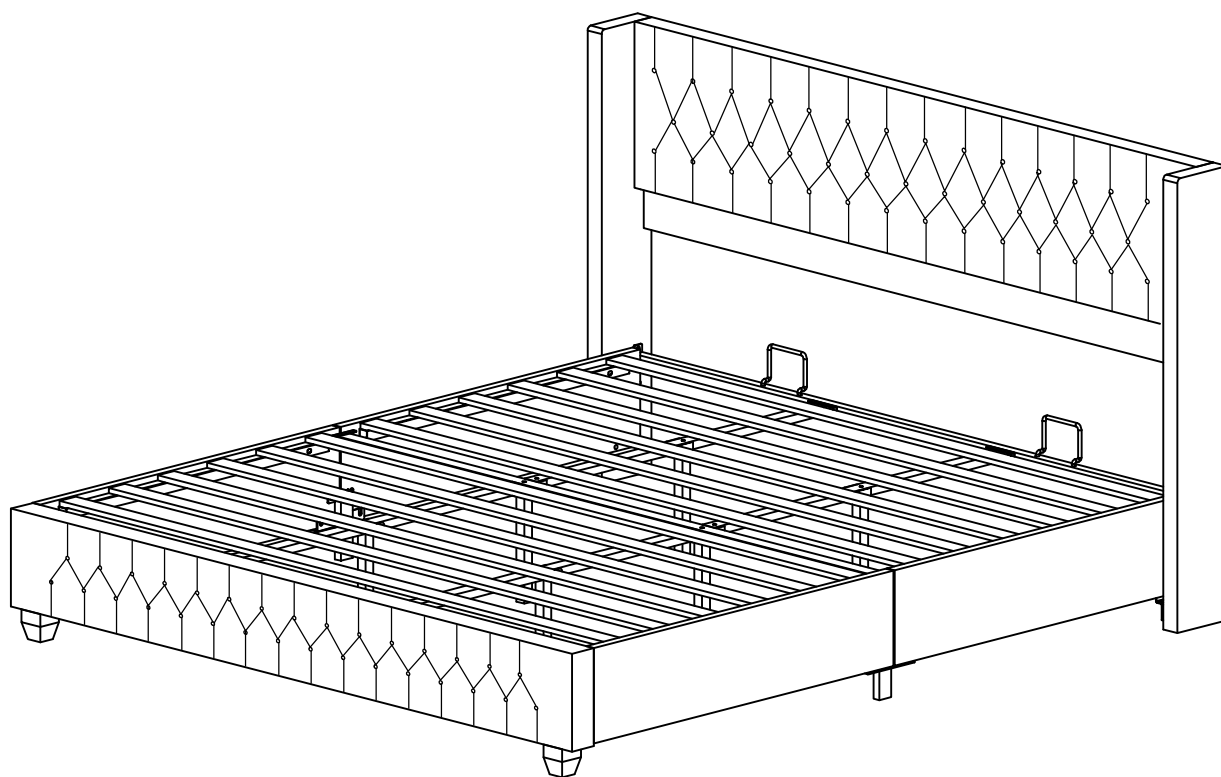

# **ANLEITUNG**

## **ASSEMBLY INSTRUCTION**

### **LE MANUEL D'EMPLOI**

#### **TIPPS**

1. Dieses Produkt wird für die Lieferung in 2 Pakete aufgeteilt. Sie kommen möglicherweise nicht gleichzeitig an. Bitte warte geduldig .
2. Wir danken Ihnen für den Einkauf! Wir bemühen uns, Ihnen qualitativ hochwertige Produkte zu bieten. In seltenen Fällen, dass Ihr Produkt beschädigt ist, Teile fehlt oder Sie auf Probleme bei der Montage stoßen, wenden Sie sich damit bitte an unseren Kundendienst, wir werden Ihnen die beste Lösung so schnell wie möglich bieten. Um Ihr Problem schnell zu lösen, bitte stellen Sie uns einige Bilder zur Verfügung, die das Produktproblem deutlich widerspiegeln können. Vielen Dank !
3. Setzen Sie die Schrauben in die Löcher ein und ziehen Sie die Schrauben an, aber nicht zu fest, 70 % ~ 80 % ist genug, und ziehen Sie schließlich alle Schrauben an. Wenn einige Schrauben nicht mit den Löchern ausgerichtet sind oder die Montage einiger Teile schwierig ist, stellen Sie bitte den Straffheitsgrad der Schrauben um.
4. Es wird empfohlen, dass 2 Personen das Produkt installieren.







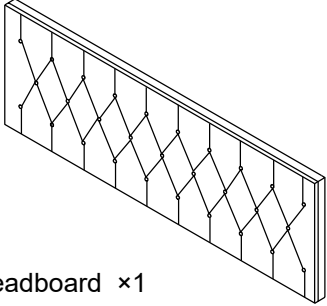
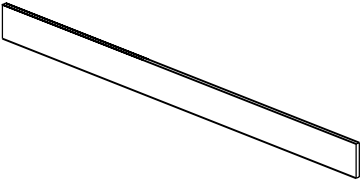

#### **TIPS**

1. Please read the instructions fully before assembly. These instructions include important information which could ensure correct assembly. We have been working on providing high quality products for you. However, in the rare instance that your product is defective, missing parts or there are some issues, please don't hesitate to contact our customer service to submit parts requirements, assembly suggestion, or warranty claims, and we will give the best solution as soon as possible. If necessary, we need you to provide some more clear pictures of the issue.
2. Thank you for shopping! We strive to provide you with high quality products. In rare cases that your product is damaged, missing parts or you encounter assembly problems, please contact our customer service with it, we will offer you the best solution as soon as possible. In order to solve your problem quickly, please provide us with some pictures that can clearly reflect the product problem. Thanks very much !
3. Insert the screws in holes and tighten the screws, but not too tight, 70%~80% is ok, finally tighten all the screws. If some issues happened that some screws can not target to the hole or some parts are difficult to install, please adjust the tightness of the screws.
4. 2 people are recommended to finish.

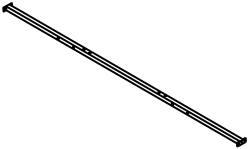
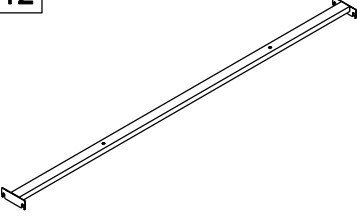
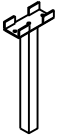
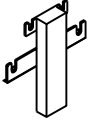
#### **CONSEILS**

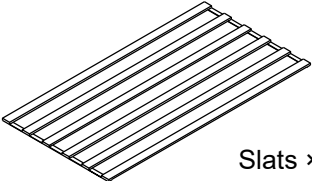
1. Veuillez lire attentivement les instructions avant le montage. Ces instructions contiennent des informations importantes qui pourraient garantir un montage correct. Nous avons travaillé pour vous fournir des produits de haute qualité. Cependant, dans les rares cas où votre produit est défectueux, s'il manque des pièces ou s'il y a des problèmes, n'hésitez pas à contacter notre service client pour soumettre des exigences de pièces, des suggestions d'assemblage ou des réclamations de garantie, et nous vous donnerons la meilleure solution comme dès que possible. Si nécessaire, nous avons besoin que vous fournissiez des images plus claires du problème.
2. Merci pour vos achats ! Nous nous efforçons de vous fournir des produits de haute qualité. Dans les rares cas où votre produit est endommagé, des pièces manquantes ou que vous rencontrez des problèmes de montage, veuillez contacter notre service client avec celui-ci, nous vous proposerons la meilleure solution le plus vite possible. Afin de résoudre votre problème rapidement, veuillez nous fournir des images qui peuvent clairement refléter le problème du produit. Merci beaucoup !
3. Insérez les vis dans les trous et serrez les vis, mais pas trop serré, 70% ~ 80% est ok, enfin serrez toutes les vis. Si certains problèmes surviennent, certaines vis ne peuvent pas viser le trou ou certaines pièces sont difficiles à installer, veuillez ajuster le serrage des vis.
4. Deux personnes sont recommandées pour le terminer.



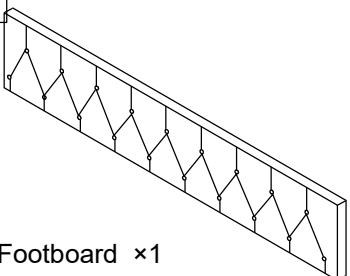
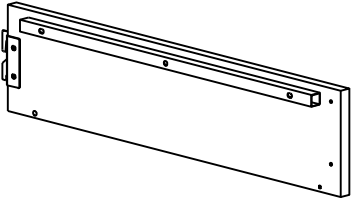
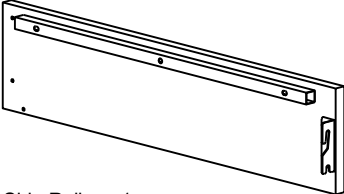
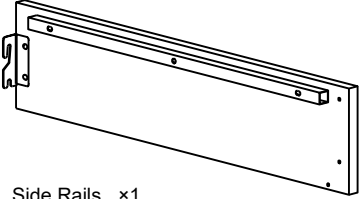
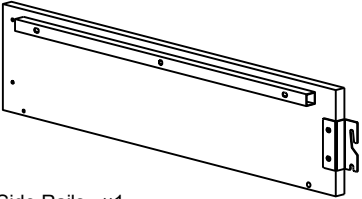
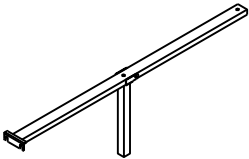

# WF310000

|  |   |  |
|--|---|--|
| <p><b>1</b></p>  <p>Headboard ×1</p>      | <p><b>2</b></p>  <p>Headboard ×1</p>   | <p><b>4</b></p>  <p>Head board leg ×1</p> |
| <p><b>5</b></p>  <p>Head board leg ×1</p> | <p><b>10</b></p>  <p>Side Rails ×1</p> | <p><b>12</b></p>  <p>×1</p>                |
| <p><b>13</b></p>  <p>×2</p>               | <p><b>14</b></p>  <p>×2</p>            | <p><b>15</b></p>  <p>×2</p>               |
| <p><b>16</b></p>  <p>Slats ×2</p>        | <p><b>17</b></p>  <p>×2</p>          | <p><b>18</b></p>  <p>×2</p>             |
| <p><b>19</b></p>  <p>×2</p>             | <p><b>20</b></p>  <p>×2</p>          |  |

# WF310001

|  |  |   |
|--|--|---|
| <p><b>3</b></p>  <p>Footboard ×1</p>  | <p><b>6</b></p>  <p>Side Rails ×1</p> | <p><b>7</b></p>  <p>Side Rails ×1</p>  |
| <p><b>8</b></p>  <p>Side Rails ×1</p> | <p><b>9</b></p>  <p>Side Rails ×1</p> | <p><b>11</b></p>  <p>Side Rails ×4</p> |

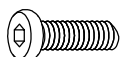
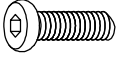
# WF310000

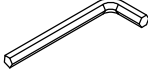
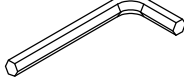
|   |   |  |   |
|---|---|--|---|
| <p><b>A</b></p>  <p>Bolts(M6x15mm) ×28</p> | <p><b>B</b></p>  <p>Bolts(M6x35mm) ×10</p> | <p><b>C</b></p>  <p>Bolts(M8x25mm) ×8</p> | <p><b>D</b></p>  <p>Bolts(M8x18mm) ×12</p> |
| <p><b>E</b></p>  <p>Bolts(M8x40mm) ×4</p>  | <p><b>F</b></p>  <p>Ø22mm 4</p>            | <p><b>G</b></p>  <p>M4 Allen Key ×1</p>   | <p><b>H</b></p>  <p>M5 Allen key ×1</p>    |
|   |   |  |   |

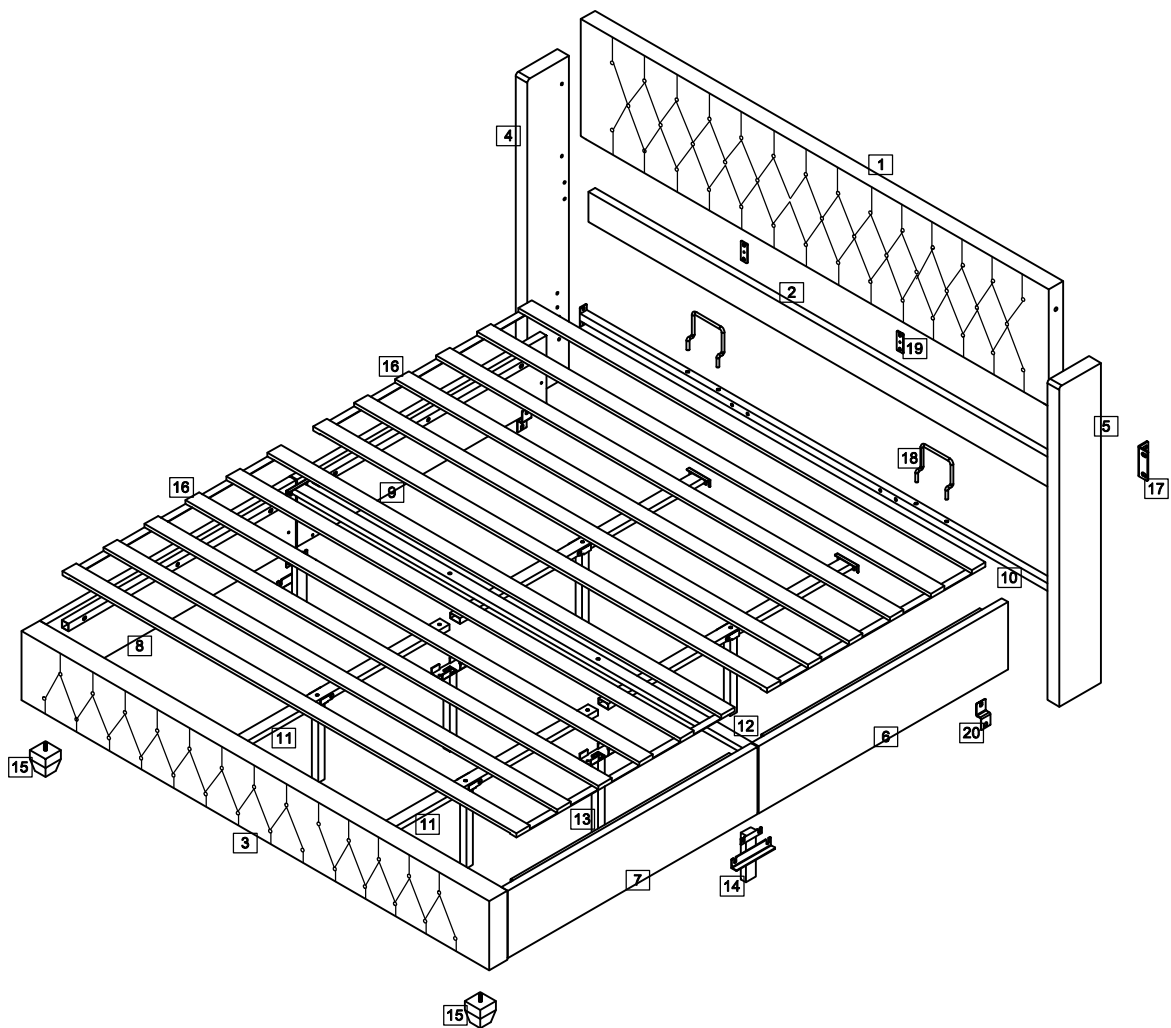

# Step 1

A



Bolts(M6x15mm) ×8

E

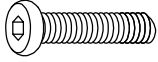

Bolts(M8x40mm) ×4

D

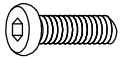

Bolts(M8x18mm) ×8

F



Ø22mm 4

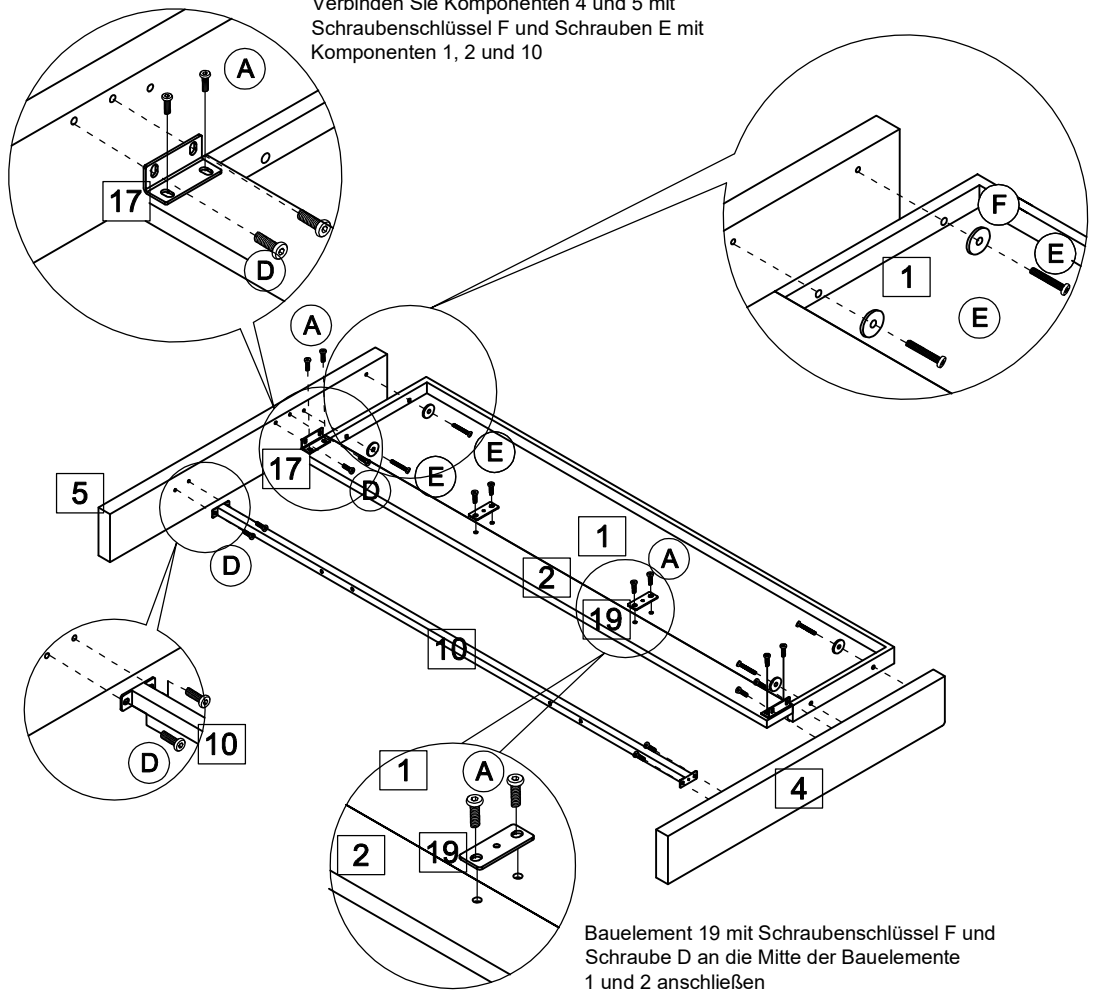

# Step 2

Drehen Sie Komponente 15, um es mit Komponente 3 zu verbinden

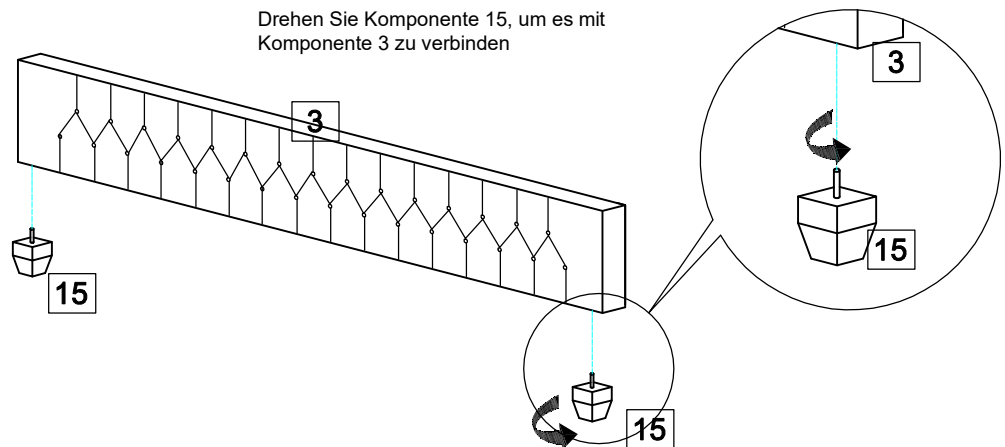

## Step 3

A



Bolts(M6x15mm) ×8

Bauteil 14 zwischen Komponenten 6 und 7 platzieren und mit Schraube B verbinden.

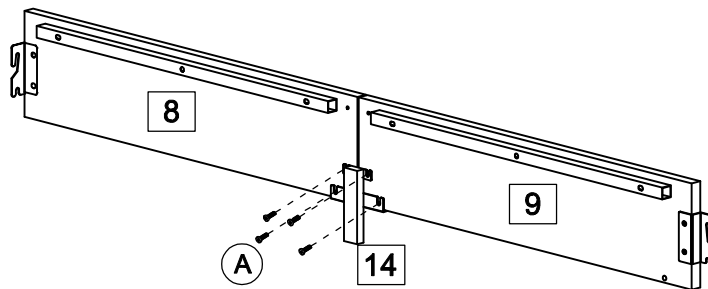
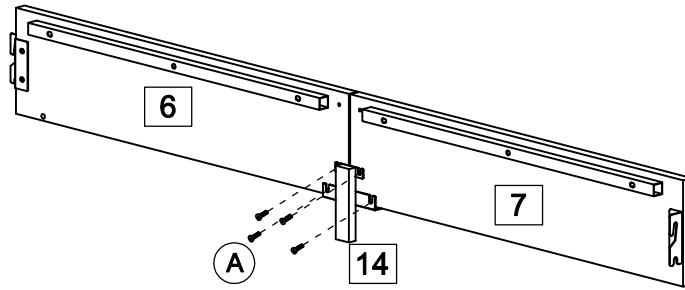

## Step 4

C



Bolts(M8x25mm) ×8

Verriegeln Sie Bauteile 6 und 7, 8 und 9 mit Schrauben C in die angezeigten Positionen.

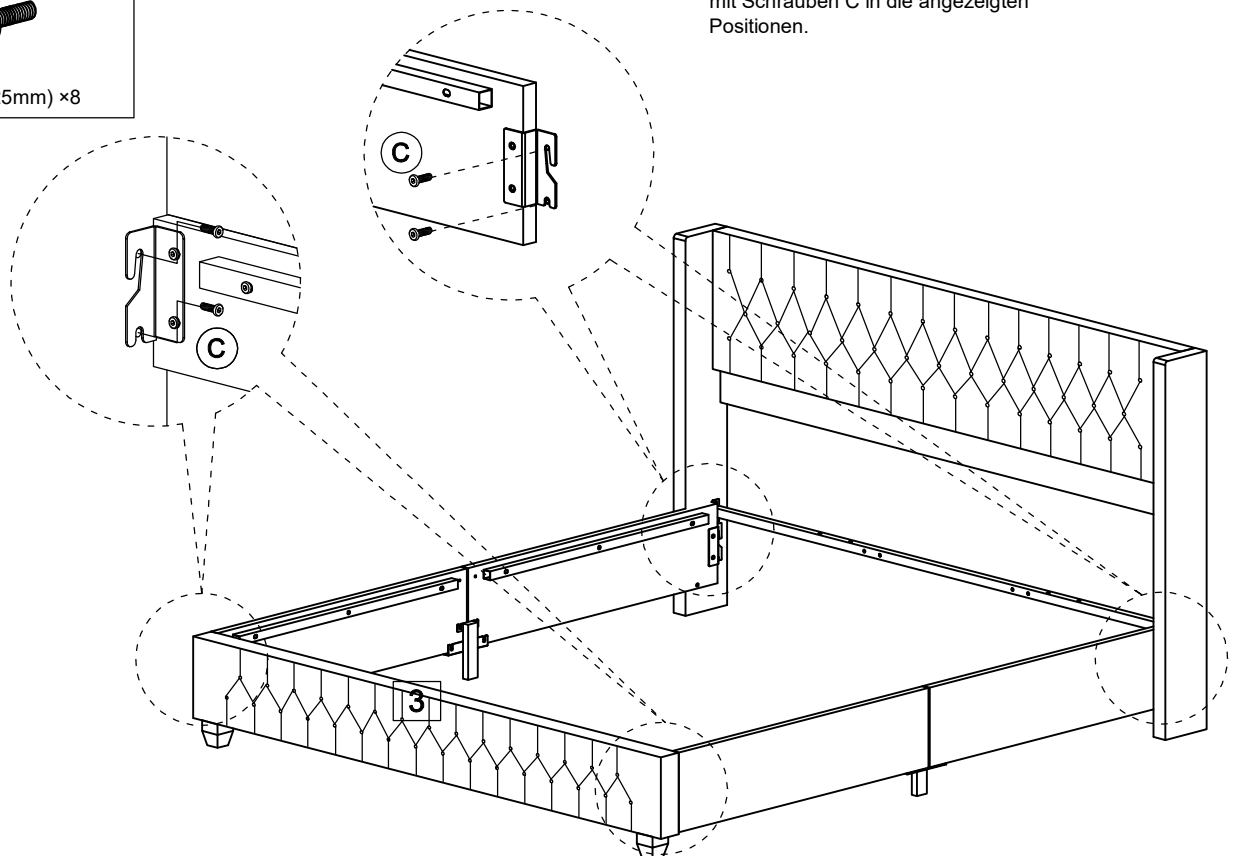

## Step 5

B

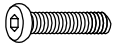

Bolts(M6x35mm) ×8

a:

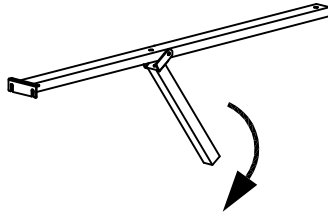

Trennen Sie den Fuß des Bauteils 11 und verbinden Sie es mit Bauteil 13 durch Schraube B in der Mitte.

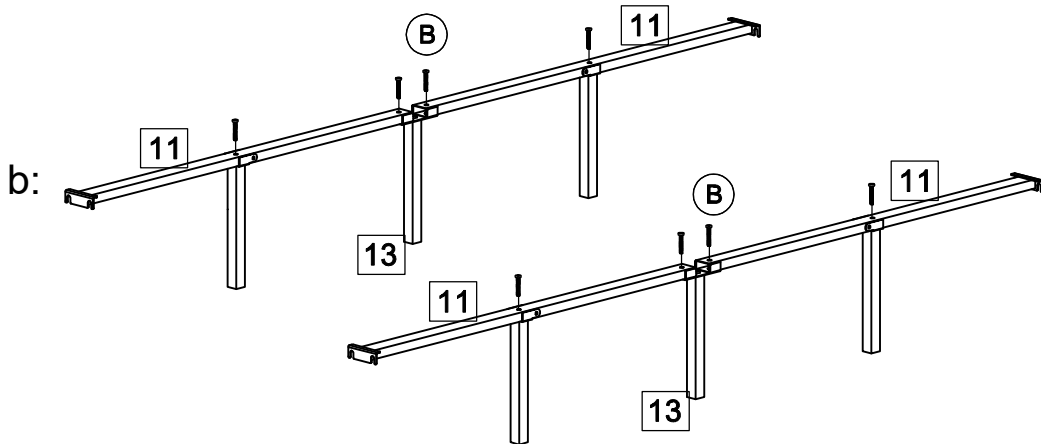

## Step 6

A



Bolts(M6x15mm) ×8

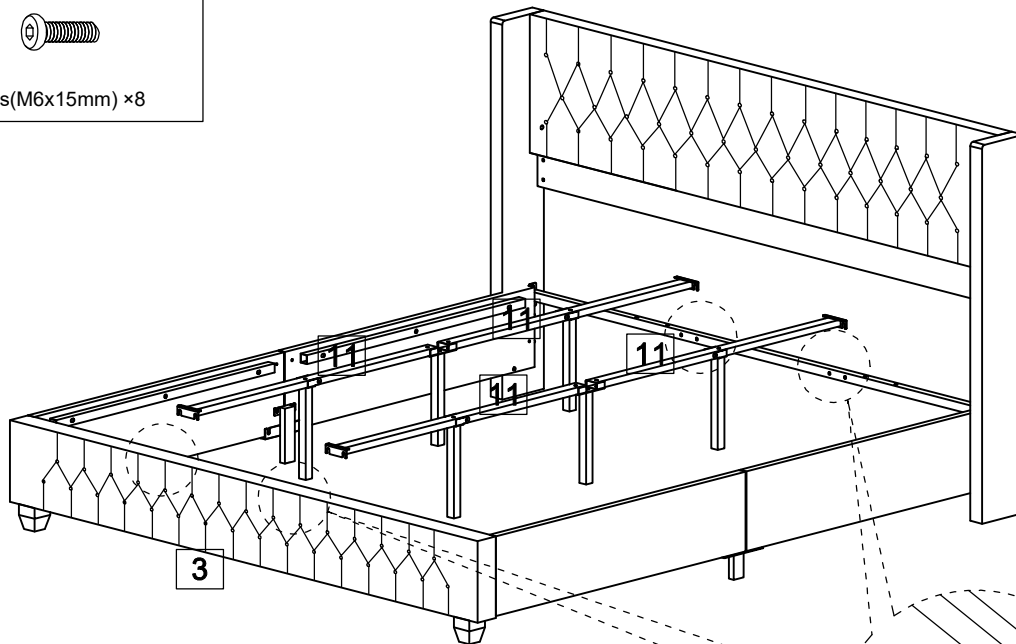

Verbinden Sie mit einem Sechskantschlüssel G das angeschlossene Bauteil 11 mit dem Bettende (3-Komponenten) und dem Bettkopf (10-Komponenten) mit Schrauben A. Achten Sie darauf, die Lochpositionen auszurichten, bevor Sie die Schrauben anziehen.

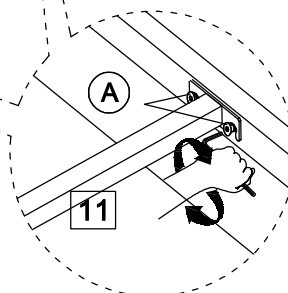

## Step 7

Verbinden Sie die Bettseite mit Komponente 12 mit Schraube A und verbinden Sie Komponente 11 mit Komponente 12 mit Schraube B, achten Sie auf die Lattenrost (16) auf Seitenplatte des Bettes kleben. Ausrichtung des Spalts.

A



Bolts(M6x15mm) ×4

B

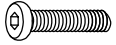

Bolts(M6x35mm) ×2

D

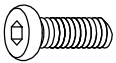

Bolts(M8x18mm) ×4

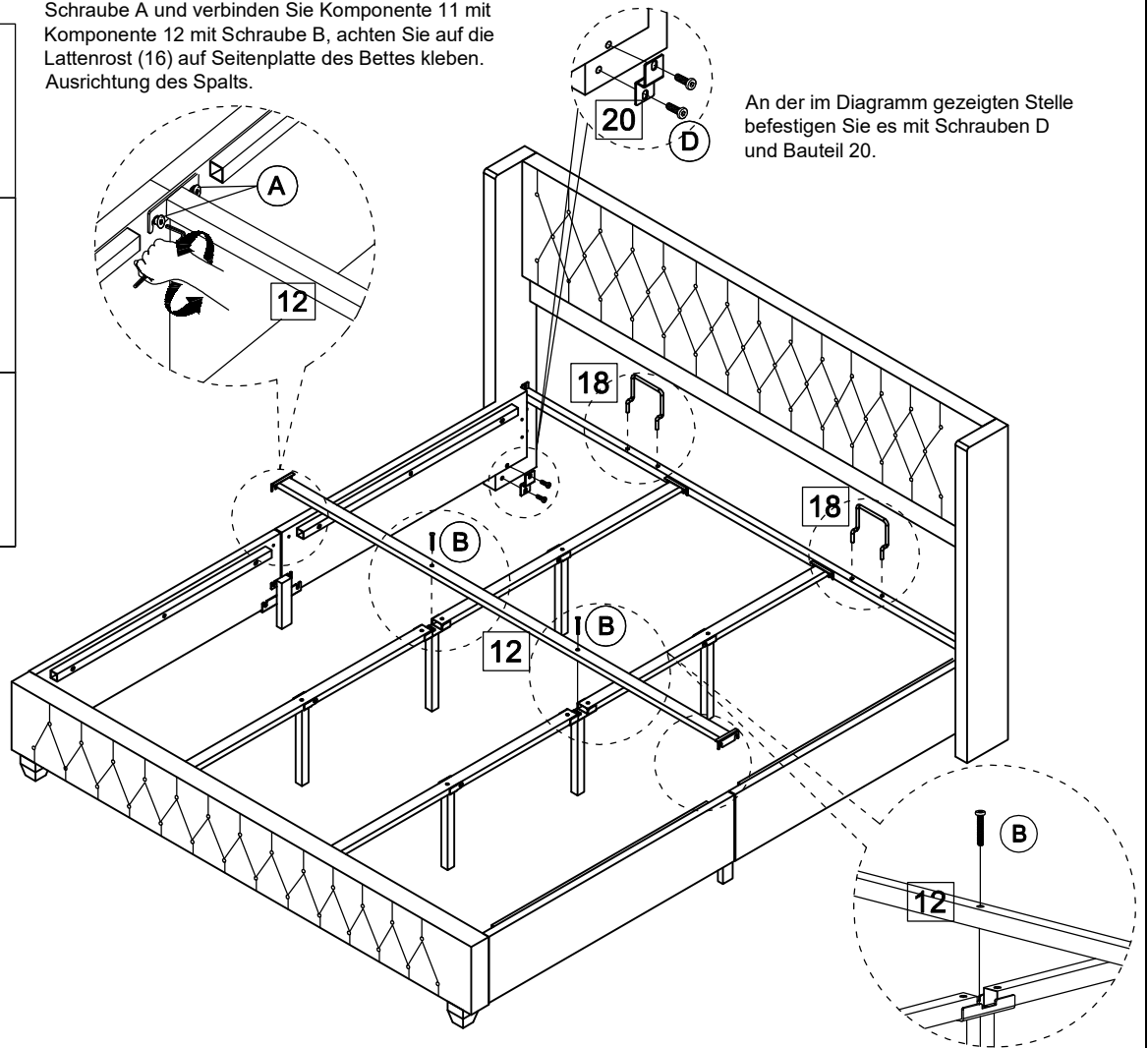

An der im Diagramm gezeigten Stelle befestigen Sie es mit Schrauben D und Bauteil 20.

## Step 8

Lattenrost (16) auf Seitenplatte des Bettes kleben.

