

MONTAGEANLEITUNG//ASSEMBLY INSTRUCTION

Artikelnummer/Item Number: N622P352206
N622P352207
N622P352208

Unser Bett wird in 3 Paketen geliefert. Die Lieferzeit dieser 3 Pakete können abweichen. bittehaben Sie etwas Geduld und vielen Dank furlhr Verstandnis.

Our bed will be sent to you in 3 packages. The delivery time of these 3 parcels may be different. Please be patient. Thank you for your understanding.

Etagenbett 200x90cm

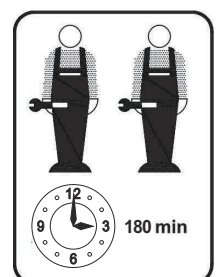
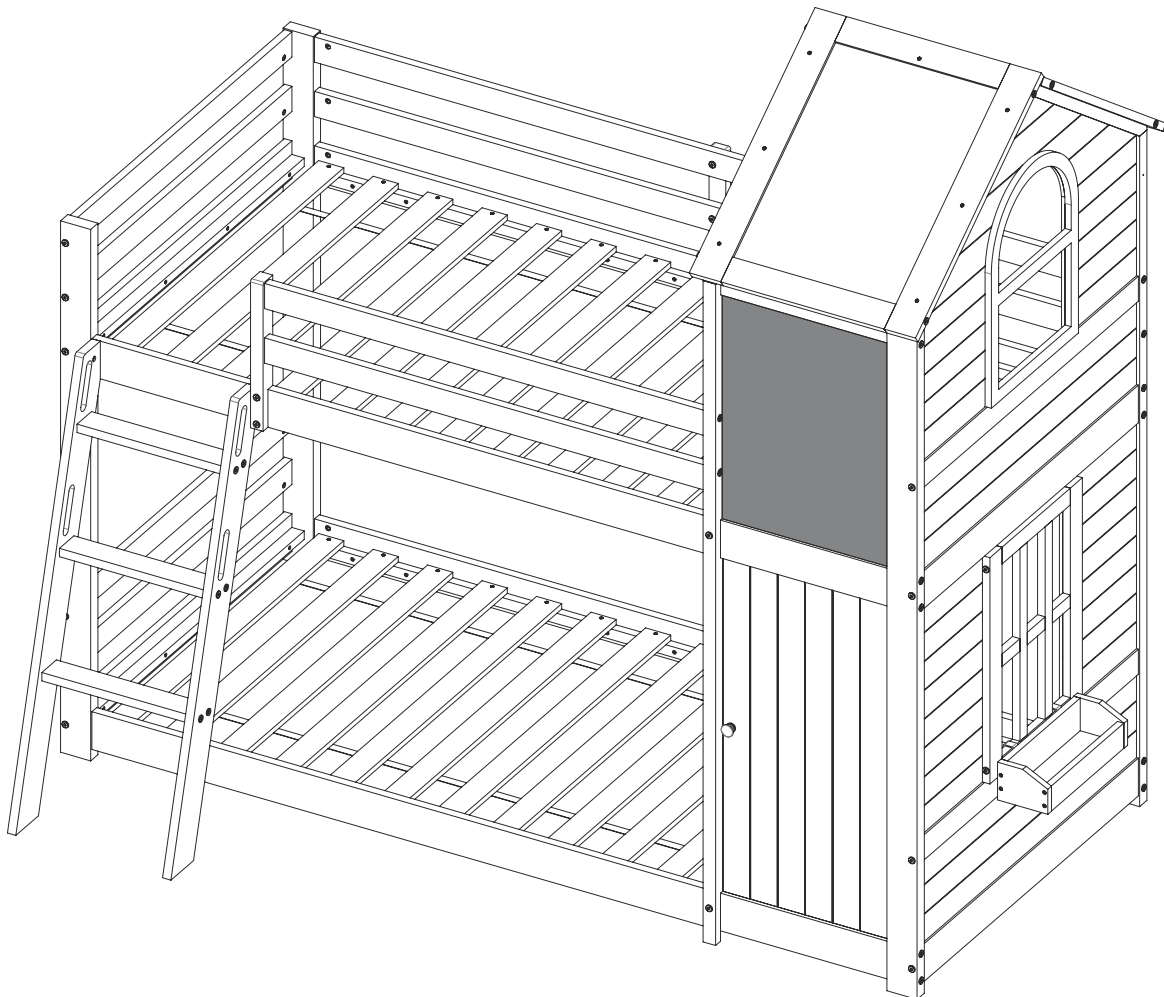

English

IMPORTANT ! KEEP FOR FUTURE REFERENCE : READ CAREFULLY

- To be assembled by an adult. Assembly must be checked by an adult before use
- WARNING ! Keep all screws, small parts and plastic bags out of the reach of children
- Properly identify all parts before assembling
- Never use your item if any of its parts are broken or missing
- Should any problems arise, please contact our After Sales Service
- Manufacturer's instructions shall be followed at all times
- Care: Clean with a soft, dry cloth. In case of larger stains, carefully rub with a slightly damp, non-abrasive sponge
- Avoid the risk of fire by not placing furniture near sources of ignition or hot items
- Do not jump on the bed

Deutsch

WICHTIG ! ZUM SPÄTEREN NACHSCHLAGEN AUFBEWAHREN: SORGFÄLTIG LESEN

- Muss von einem Erwachsenen zusammengebaut werden. Der Zusammenbau muss vor dem Gebrauch von einem Erwachsenen überprüft werden
- WARNUNG! Bewahren Sie alle Schrauben, Kleinteile und Plastikbeutel außerhalb der Reichweite von Kindern auf
- Kennzeichnen Sie vor dem Zusammenbau alle Teile richtig
- Benutzen Sie Ihren Artikel niemals, wenn Teile gebrochen sind oder fehlen
- Sollten Probleme auftreten, wenden Sie sich bitte an unseren Kundendienst
- Die Anweisungen des Herstellers sind stets zu befolgen
- Pflege: Mit einem weichen, trockenen Tuch reinigen. Bei größeren Flecken vorsichtig mit einem leicht feuchten, nicht scheuernden Schwamm abreiben. nicht scheuernden Schwamm
- Vermeiden Sie die Gefahr eines Brandes, indem Sie die Möbel nicht in der Nähe von Zündquellen oder heißen Gegenständen aufstellen
- Nicht auf das Bett springen

Français

IMPORTANT ! CONSERVER POUR RÉFÉRENCE ULTÉRIEURE : LIRE ATTENTIVEMENT

- Le montage doit être effectué par un adulte. Le montage doit être vérifié par un adulte avant Utilisation
- ATTENTION ! Tenir les vis, les petites pièces et les sachets en plastique hors de portée des enfants
- Identifiez correctement toutes les pièces avant de les assembler
- N'utilisez jamais votre article si l'une de ses pièces est cassée ou manquante
- En cas de problème, veuillez contacter notre service après-vente
- Les instructions du fabricant doivent être respectées à tout moment
- Entretien : nettoyer avec un chiffon doux et sec. En cas de taches plus importantes, frotter soigneusement avec une éponge non abrasive légèrement humide. légèrement humide et non Abrasive
- Évitez les risques d'incendie en ne plaçant pas les meubles à proximité de sources d'inflammation ou d'objets chauds
- Ne pas sauter sur le lit

Italiano

IMPORTANTE! CONSERVARE PER RIFERIMENTO FUTURO: LEGGERE ATTENTAMENTE

- Deve essere assemblato da un adulto. L'assemblaggio deve essere controllato da un adulto prima dell'uso
- **ATTENZIONE!** Tenere tutte le viti, le piccole parti e i sacchetti di plastica fuori dalla portata dei bambini
- Identificare correttamente tutte le parti prima dell'assemblaggio
- Non utilizzare mai l'articolo se alcune parti sono rotte o mancanti
- In caso di problemi, si prega di contattare il nostro Servizio Post Vendita
- Le istruzioni del produttore devono essere sempre seguite
- Cura: Pulire con un panno morbido e asciutto. In caso di macchie più estese, strofinare accuratamente con una spugna leggermente umida e nonspugna leggermente umida e non abrasiva
- Evitare il rischio di incendio, non collocando i mobili vicino a fonti di accensione o a oggetti caldi
- Non saltare sul letto

Español

¡ IMPORTANTE ! CONSERVELO PARA FUTURAS CONSULTAS: LEA ATENTAMENTE

- Debe ser montado por un adulto. El montaje debe ser comprobado por un adulto antes del uso
- ADVERTENCIA Mantenga todos los tornillos, piezas pequeñas y bolsas de plástico fuera del alcance de los niños.
- Identifique correctamente todas las piezas antes de montarlas
 - Nunca utilice su artículo si alguna de sus piezas está rota o falta
 - Si surge algún problema, póngase en contacto con nuestro Servicio Postventa
 - Las instrucciones del fabricante deben seguirse en todo momento
 - Cuidado: Limpiar con un paño suave y seco. En caso de manchas más grandes, frote cuidadosamente con una esponja no abrasiva ligeramente humedecida.
 - Evite el riesgo de incendio no colocando los muebles cerca de fuentes de ignición u objetos calientes.
 - No saltar sobre la cama.

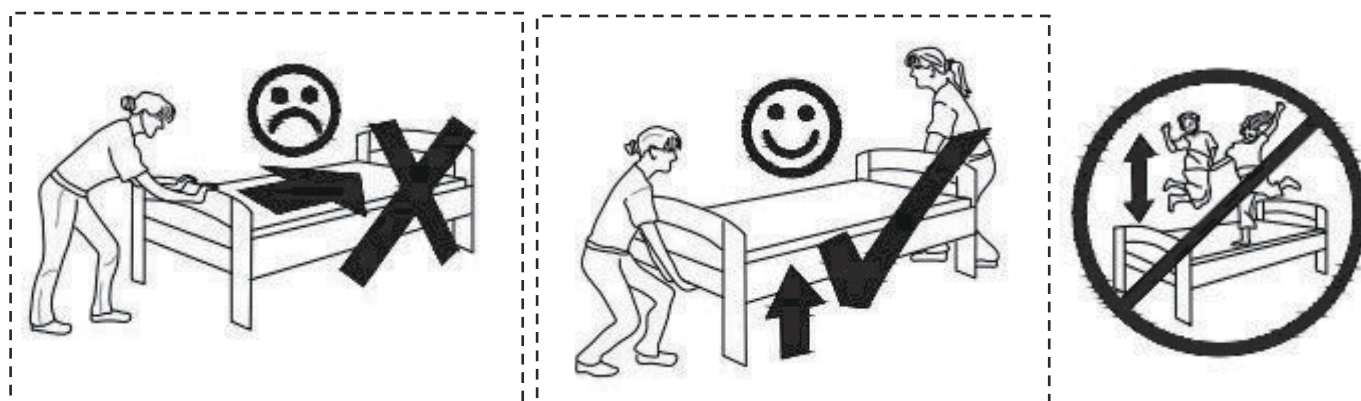

INSTRUCTIONS

IMPORTANT-READ CAREFULLY-RETAIN FOR FUTURE REFERENCE

- a) **WARNING** -Children can become trapped between the bed and the wall, the adjoining pieces of furniture (e.g. cupboards) and the like. To avoid risk of serious injury the distance between the safety barrier and the adjoining structure shall not exceed 90 mm or shall be more than 230 mm.
- b) **WARNING**-Do not use the bed if any structural part is broken or missing; Replacement parts are between requested from the manufacturer or the store.
- c) **WARNING**-Do not climb or wiggle on any non-designated structures.
- d) it is imperative to always follow the installation instructions and manufacturer's use.
- e) **The recommended size of the mattress to be used with the bed is 200cmx90cm, maximum thickness mattress:13cm.**
- f) It is necessary to ventilate the room in order to maintain a low level moisture and prevent mold growth in the bed and its periphery.
- g) Joining devices should always be tightened properly and regularly verified. Tighten if necessary.
- i) **Meets European standard requirements NC safety EN 747-1:2024.**

ANLEITUNGEN

WICHTIG - SORGFÄLTIG LESEN - FÜR SPÄTERE VERWENDUNG

AUFBEWAHREN

- a) **WARNUNG** - Kinder können zwischen dem Bett und der Wand, den angrenzenden Möbelstücken (z. B. Schränken) und der Lücke eingeklemmt werden. Um die Gefahr schwerer Verletzungen zu vermeiden, darf der Abstand zwischen der Sicherheitsbarriere und der angrenzenden Struktur nicht mehr als 90 mm oder mehr als 230 mm betragen.
- b) **WARNUNG**-Das Bett darf nicht benutzt werden, wenn ein Bauteil gebrochen ist oder fehlt; Ersatzteile sind beim Hersteller oder im Geschäft anzufordern.
- c) **WARNUNG** - Klettern oder wackeln Sie nicht auf nicht dafür vorgesehenen Strukturen.
- d) Befolgen Sie unbedingt die Installationsanweisungen und die Gebrauchsanweisungen des Herstellers.
- e) **Die empfohlene Größe der Matratze für das Bett beträgt 200x90cm, maximale Dicke der Matratze: 13cm.**
- f) Es ist notwendig, den Raum zu lüften, um die Feuchtigkeit niedrig zu halten und Schimmelbildung im Bett und seiner Umgebung zu verhindern.
- g) Die Verbindungselemente sollten immer richtig angezogen sein und regelmäßig überprüft werden. Ziehen Sie sie gegebenenfalls nach.
- i) **Meets European standard requirements NC safety EN 747-1:2024.**



DE: Vor dem Einbau die Schrauben in die Löcher stecken und festziehen, aber nicht bis 100%, 70% bis 80% anziehen reicht aus. Schließlich, nachdem alle Schrauben installiert sind, ziehen Sie alle Schrauben auf 100%.

Wenn Sie auf diese Probleme stoßen, wie z. B. Fehlausrichtung der Löcher oder Unfähigkeit, bestimmte Teile zu installieren, überprüfen Sie bitte, ob die Schrauben korrekt verwendet werden und passen Sie die Dichtigkeit der Schrauben an.

UK: Before installation, insert the screws into the holes and tighten them, but do not tighten them to 100%, 70% to 80% is sufficient. Finally, after all screws are installed, tighten all screws to 100%.

If you encounter these issues, such as if the holes cannot be aligned or some parts cannot be installed, please check if the screws are used correctly and adjust the tightness of the screws.

FR: Insérer la vis dans le trou avant la fin de l'assemblage, serrer la vis, mais ne pas serrer à 100%, 70% ~ 80% est correct. Enfin, une fois que toutes les vis sont bien serrées, toutes les vis sont serrées à 100%.

Si vous rencontrez ces problèmes, par exemple si les trous ne sont pas alignés ou si certaines pièces ne peuvent pas être montées, vérifiez que les vis sont utilisées correctement et Ajustez leur serrage.

Stückliste 1/2

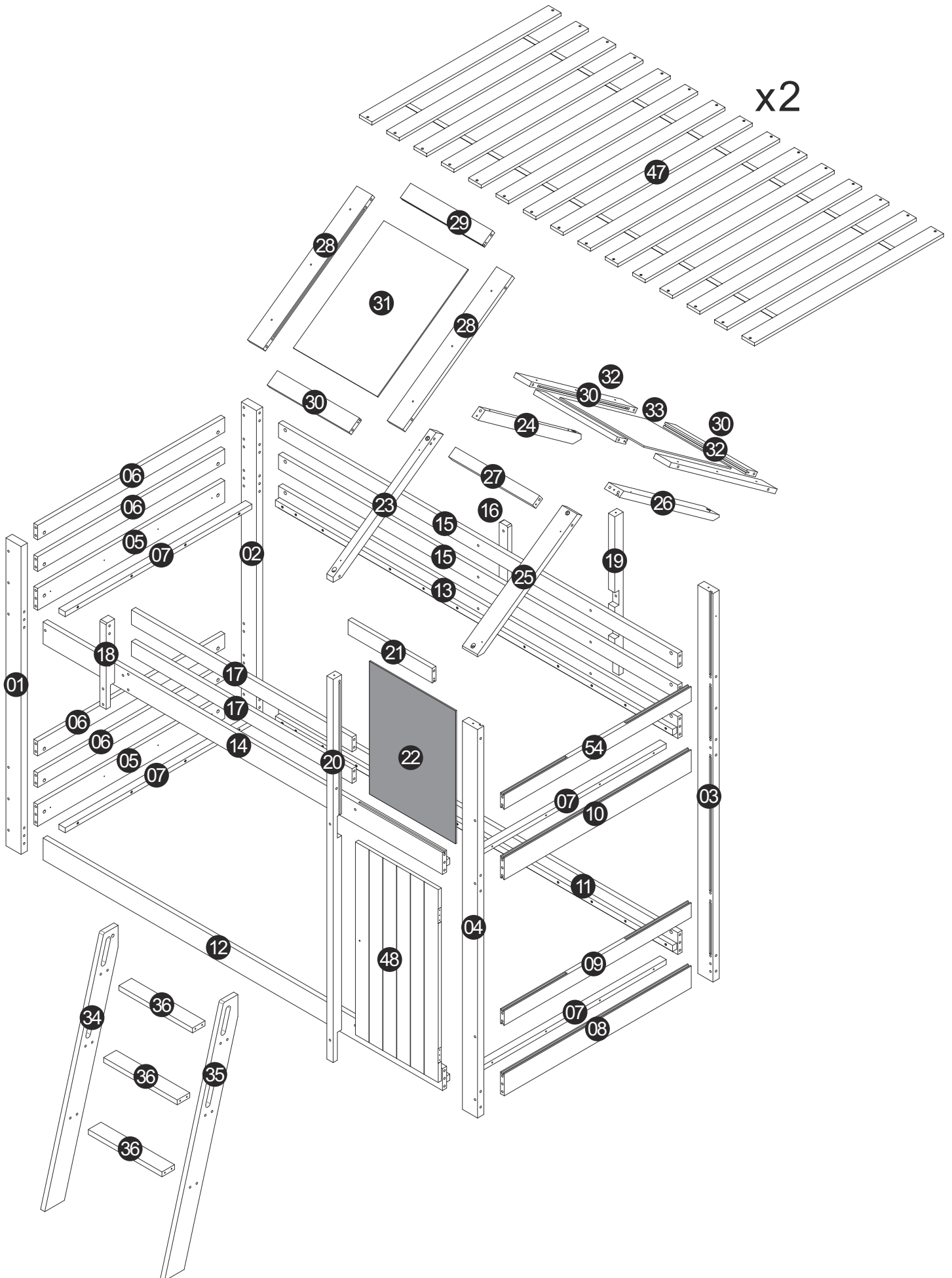



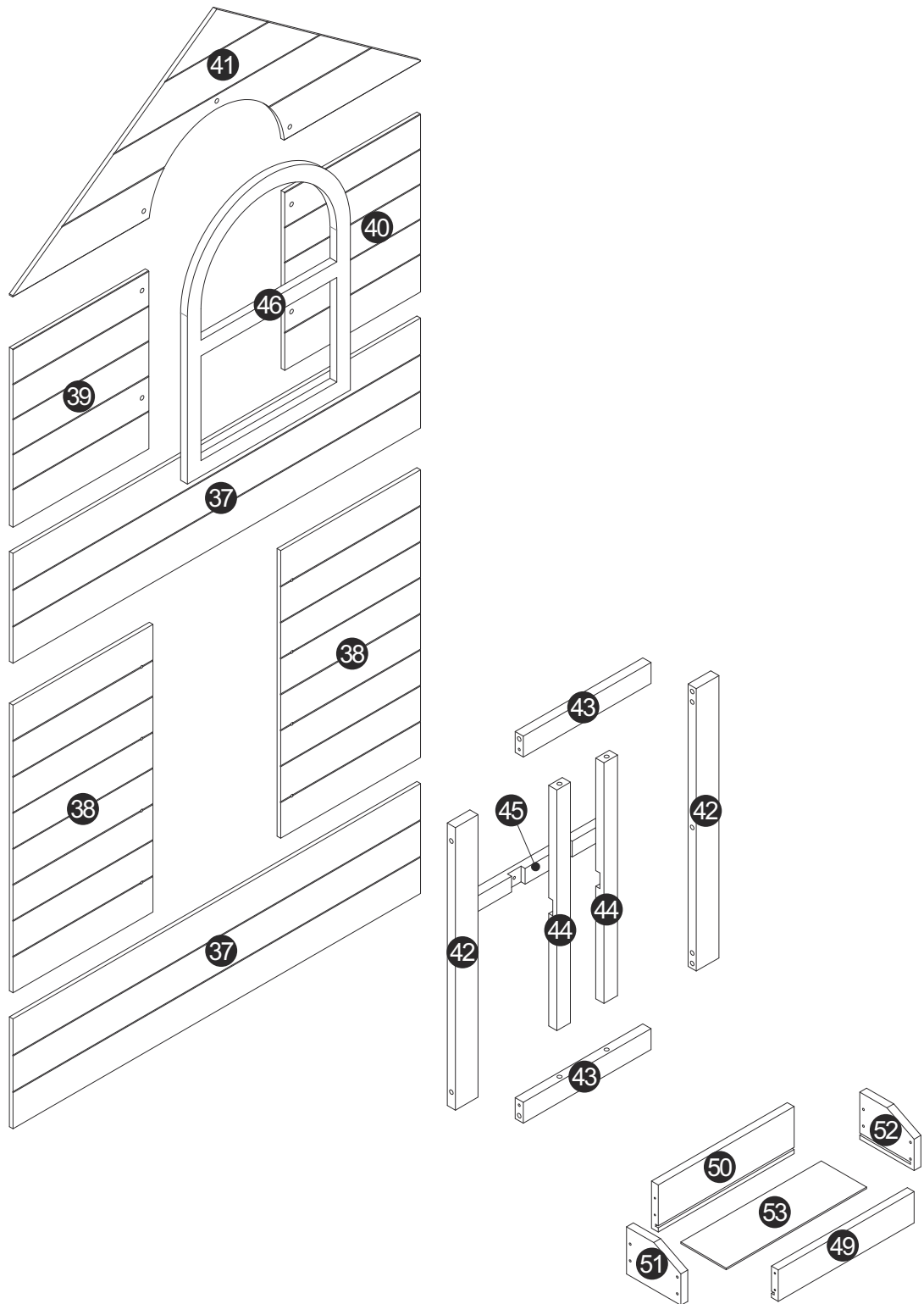



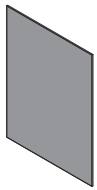
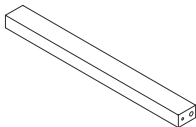
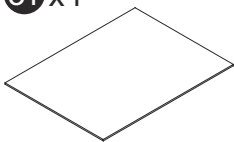
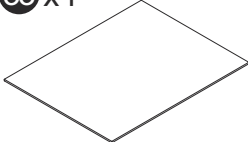
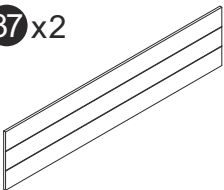
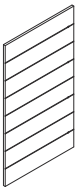
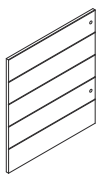
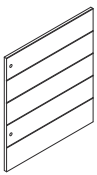
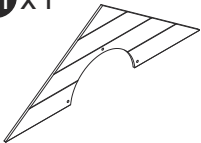
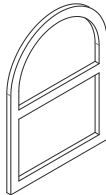
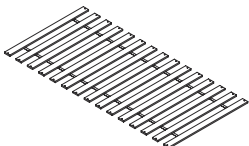
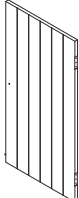



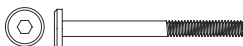

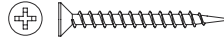
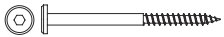
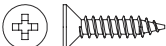

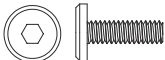
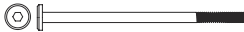
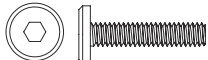
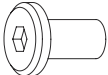
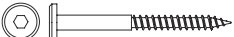
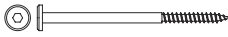
Stückliste 2/2

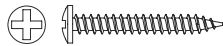

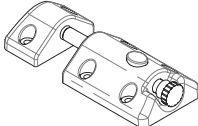



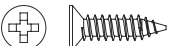
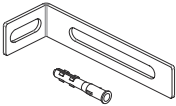

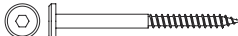
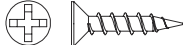

N622P352206

22x1 	27x1 	31x1 	33x1 	37x2 
38x2 	39x1 	40x1 	41x1 	46x1 
47x1 	48x1 			



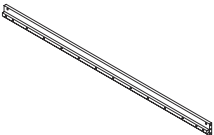
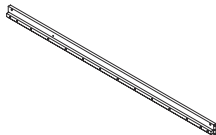
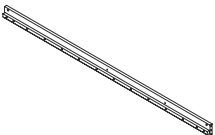
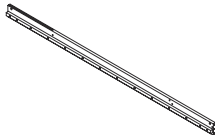
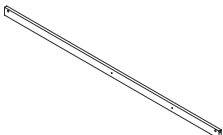
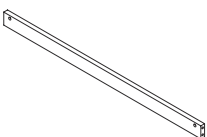

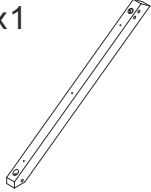
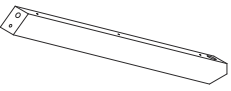
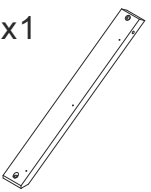
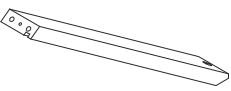
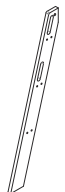
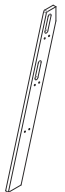
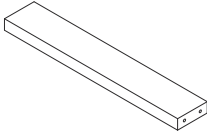

Hardware-Liste N622P352206

A x24  M6x70	B x46 	C x69  Φ8x30	D x24  Φ4x40	E x4  Φ6x90
F x4  Φ3.5x16	G x8  Φ4x20	H x7  M6x20	J x20  M6x120	K x10  M6x30
L x10 	M x17  Φ6x70	N x10  Φ6x110	P x2  M6x50	Q x2  Φ6x50
R x13  Φ4x30	S x2 	T x2 	U x72  Φ3x30	V x1 
W x2 	X x4  Φ3.5x14	Y x2 	Z x4  Φ4x30	AAx2 
ABx1  Φ6x80	ACx12  Φ3x16			

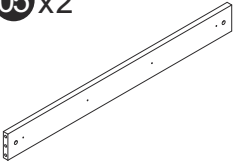
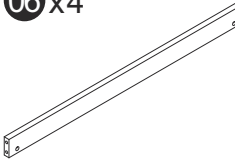
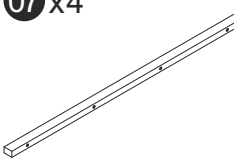
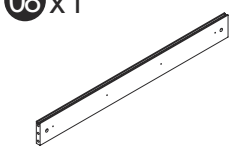
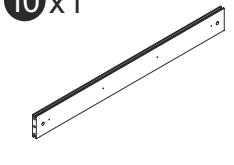
N622P352207

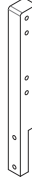
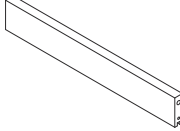
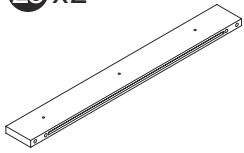
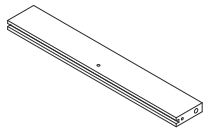
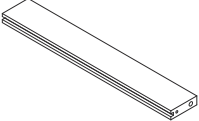
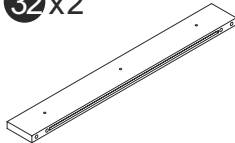
01 x1 	02 x1 	03 x1 	04 x1 	09 x1 
11 x1 	12 x1 	13 x1 	14 x1 	15 x2 
17 x2 	19 x1 	20 x1 	23 x1 	24 x1 
25 x1 	26 x1 	34 x1 	35 x1 	36 x3 
54 x1 				

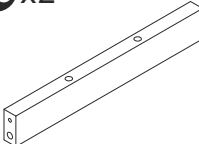
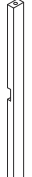
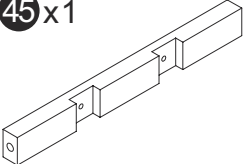
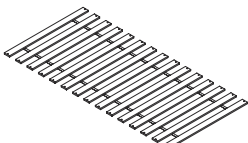
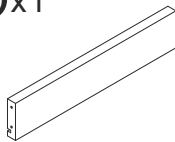
N622P352208

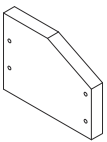
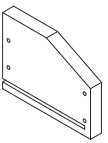
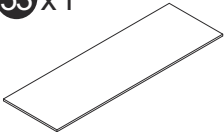
<p>05x2</p> 	<p>06x4</p> 	<p>07x4</p> 	<p>08x1</p> 	<p>10x1</p> 
<p>16x1</p> 	<p>18x1</p> 	<p>21x1</p> 	<p>28x2</p> 	<p>29x1</p> 
<p>30x3</p> 	<p>32x2</p> 	<p>42x2</p> 	<p>43x2</p> 	<p>44x2</p> 
<p>45x1</p> 	<p>47x1</p> 	<p>49x1</p> 	<p>50x1</p> 	<p>51x1</p> 
<p>52x1</p> 	<p>53x1</p> 			

Schritt 1

C

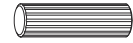

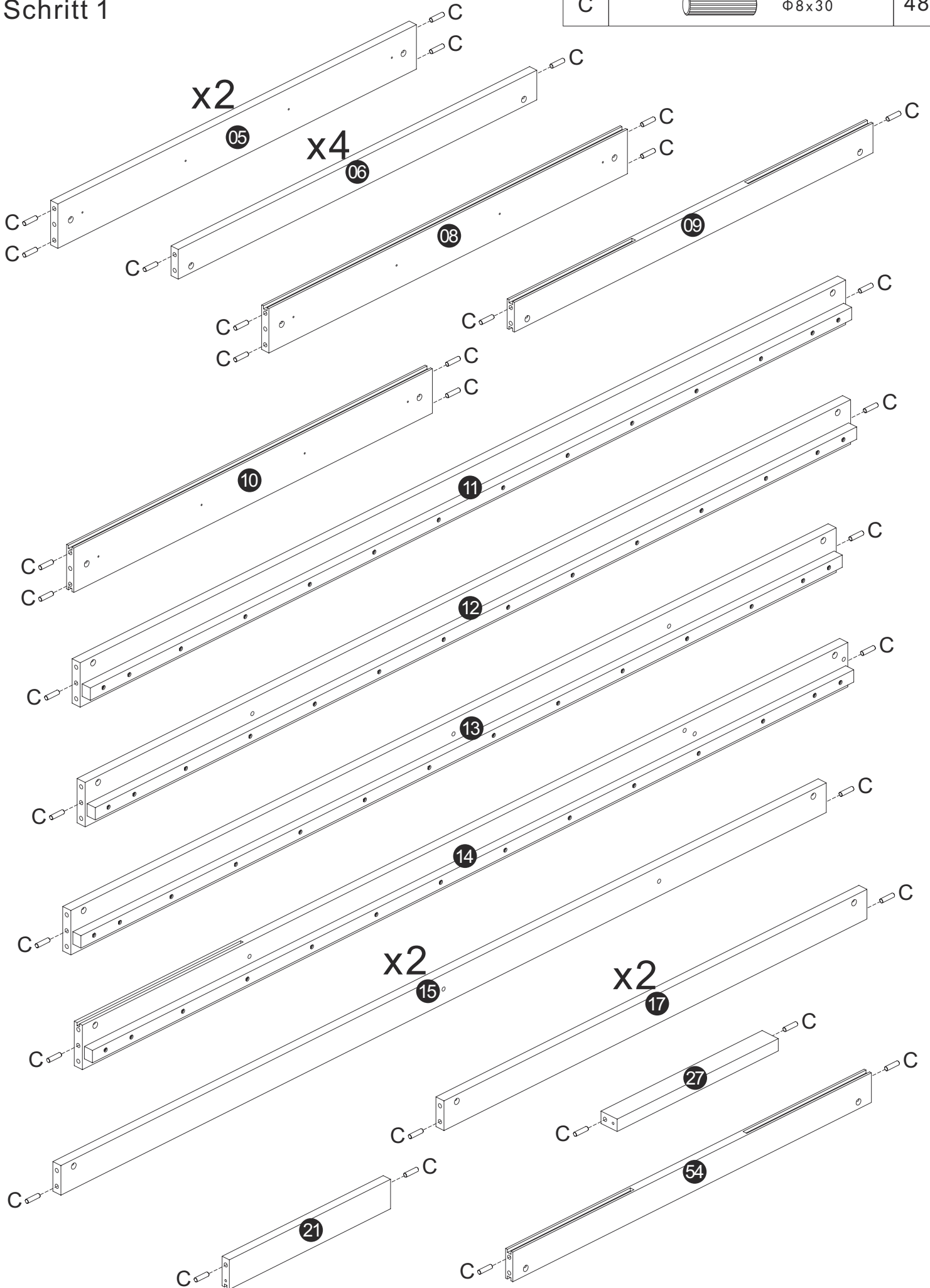

Φ8x30

48

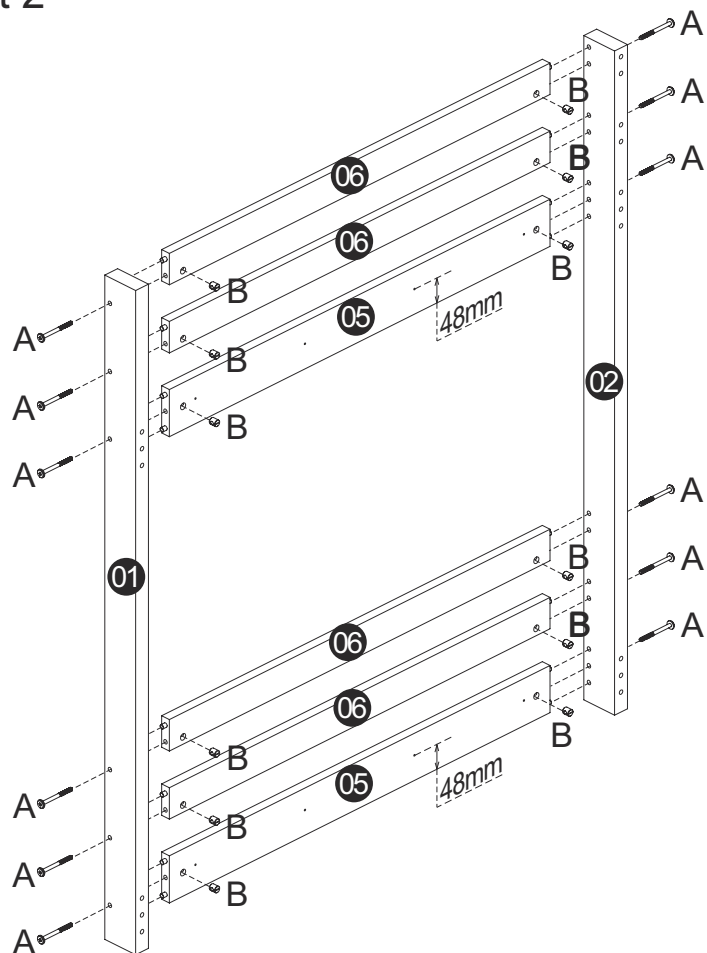

Schritt 2

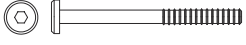

A	 M6x70	12
B		12

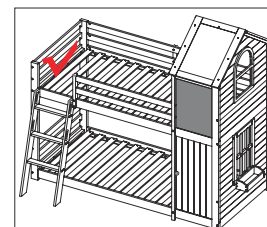

Schritt 3

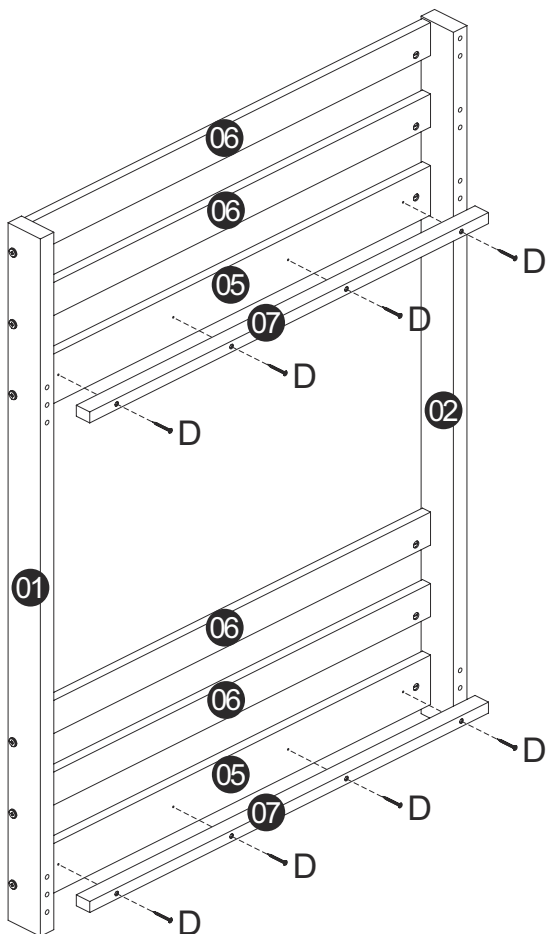

D	 Φ4x40	8
---	---	---

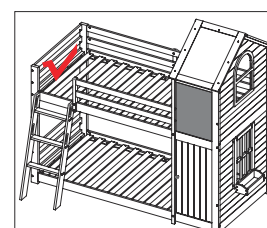

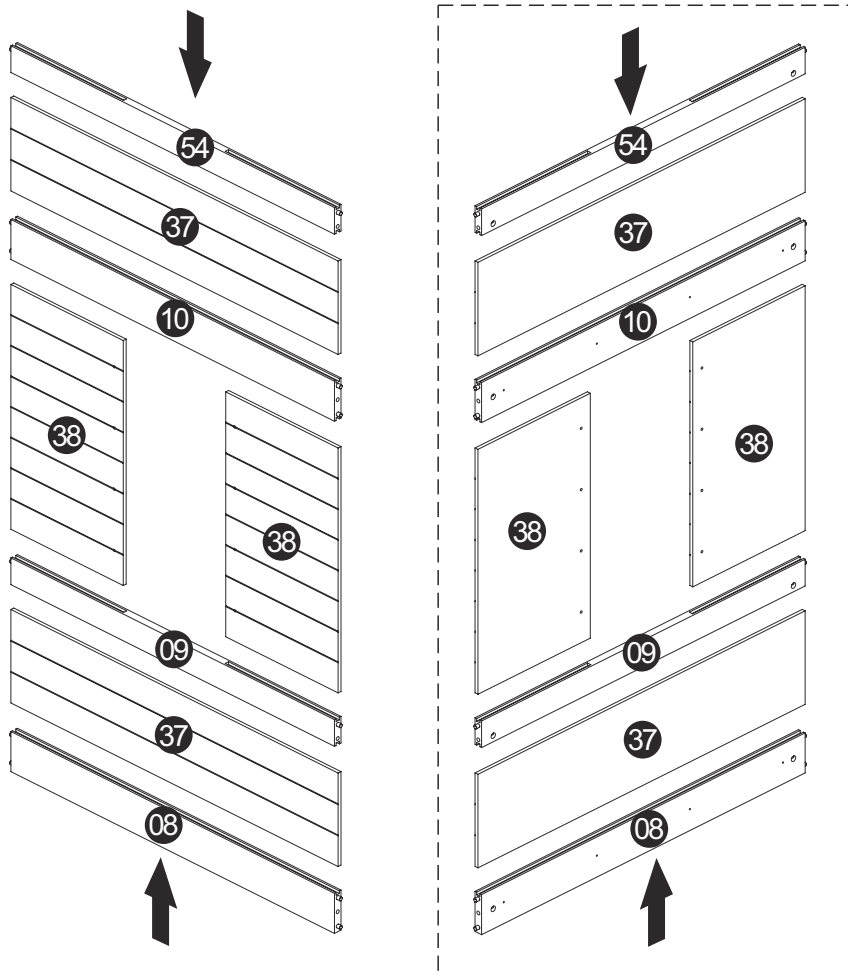

Schritt 4

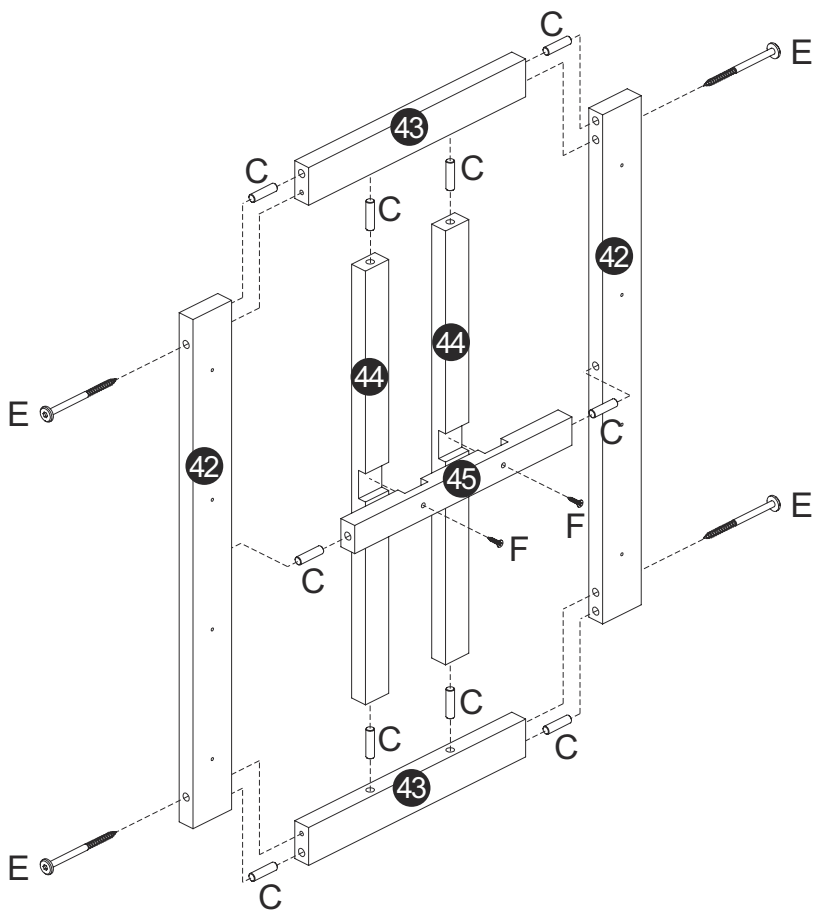

Schritt 5

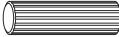

C		$\Phi 8 \times 30$	10
E		$\Phi 6 \times 90$	4
F		$\Phi 3.5 \times 16$	2

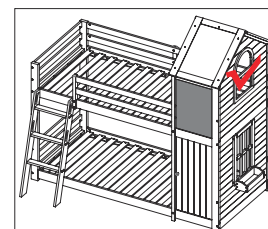

Schritt 6

G



Φ4x20

8

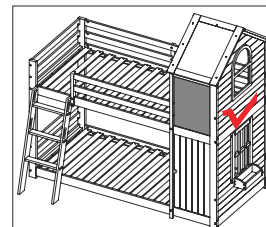
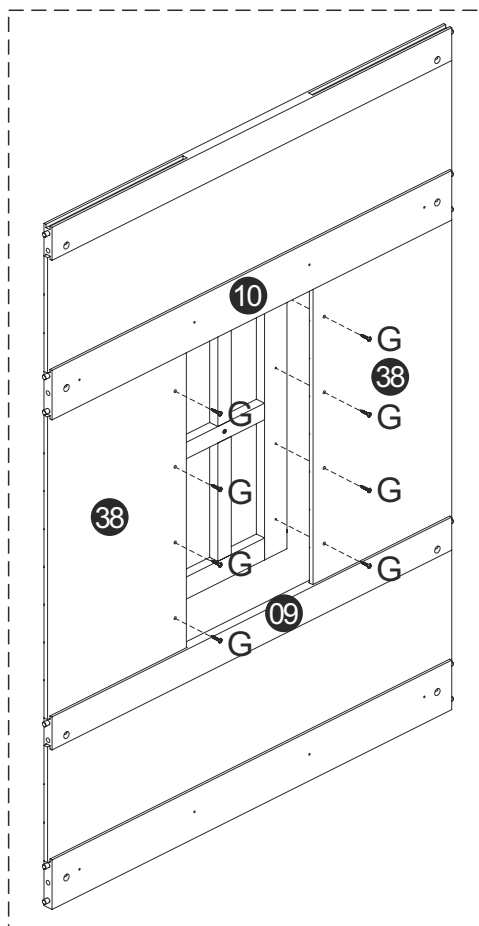
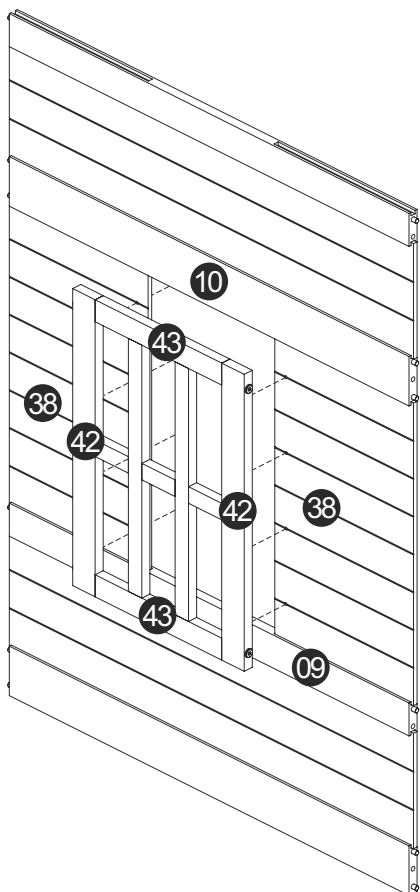

Schritt 7

A



M6x70

8

B



8

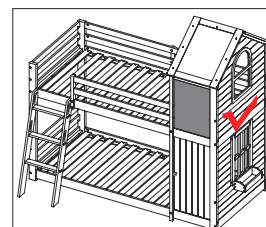
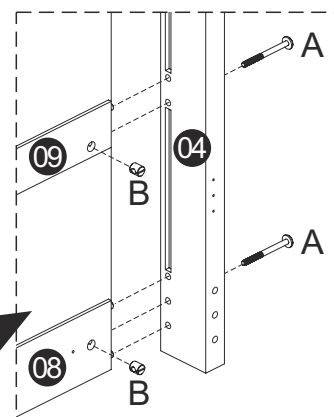
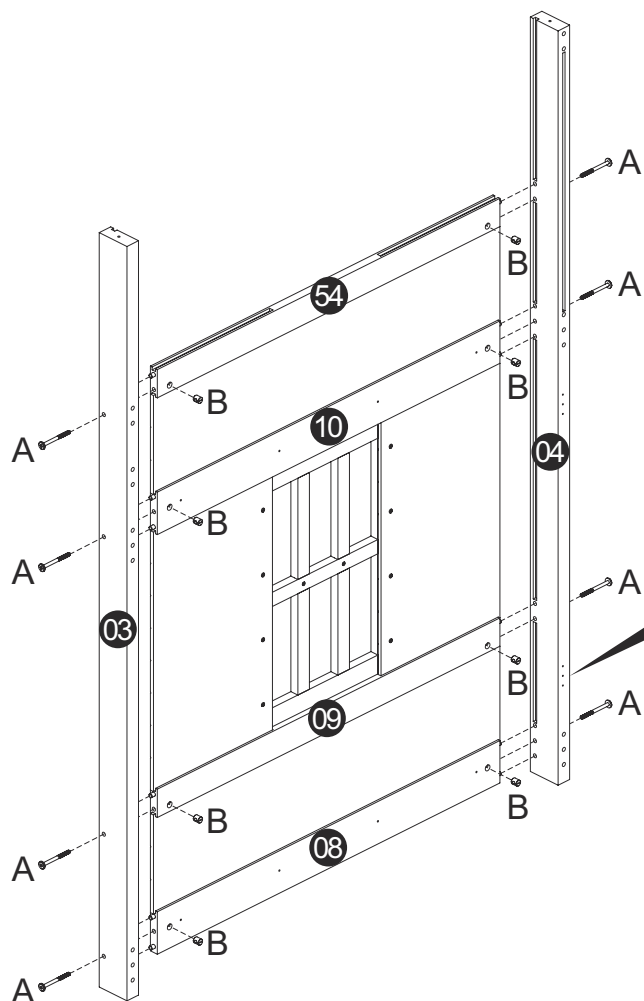

Schritt 8

H		M6x20	7
---	--	-------	---

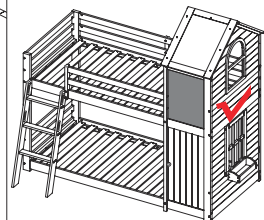
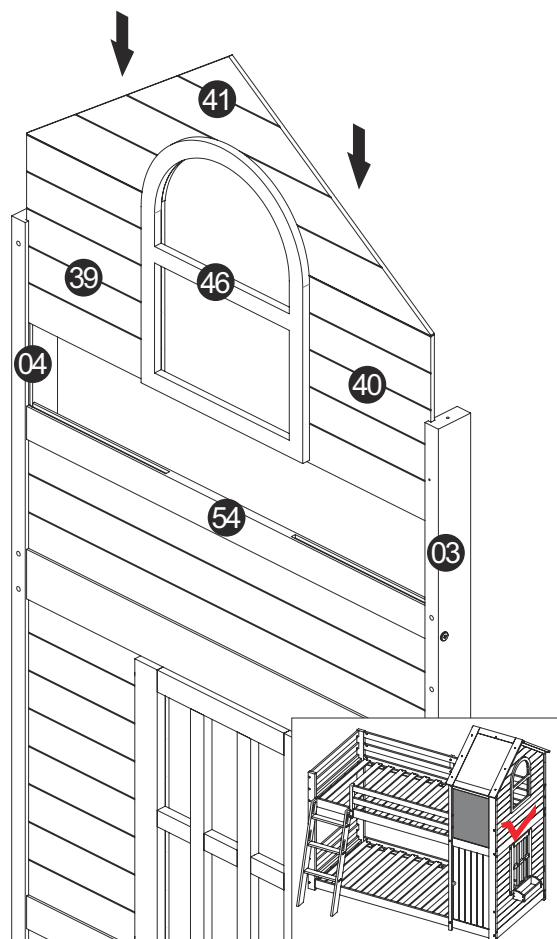
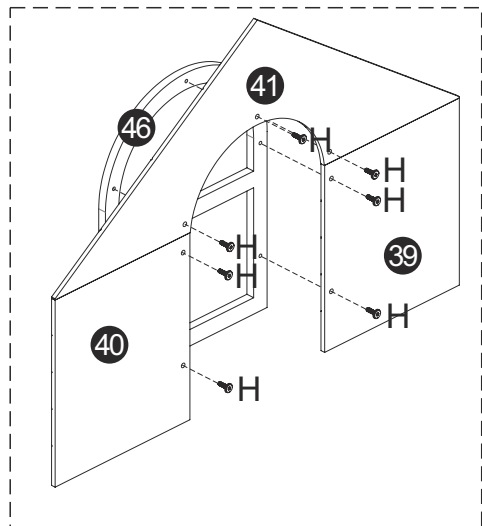
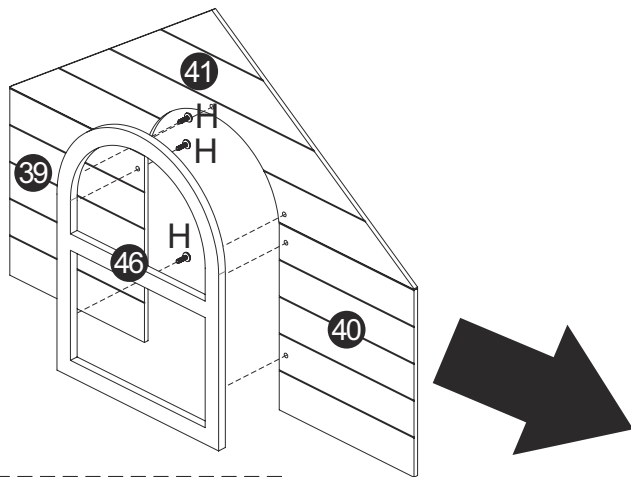

Schritt 9

D		Φ4x40	8
---	---	-------	---

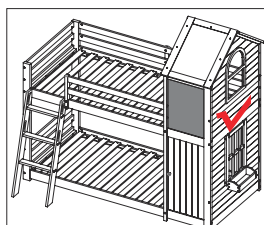
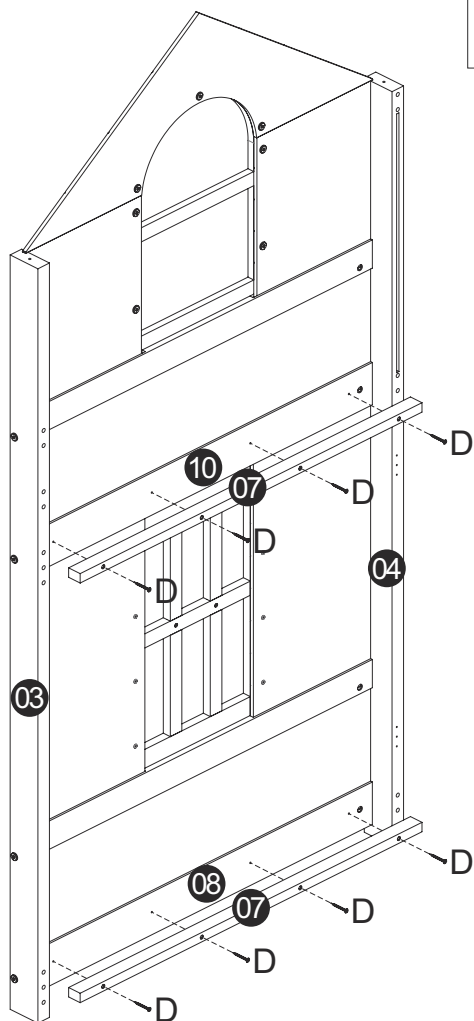



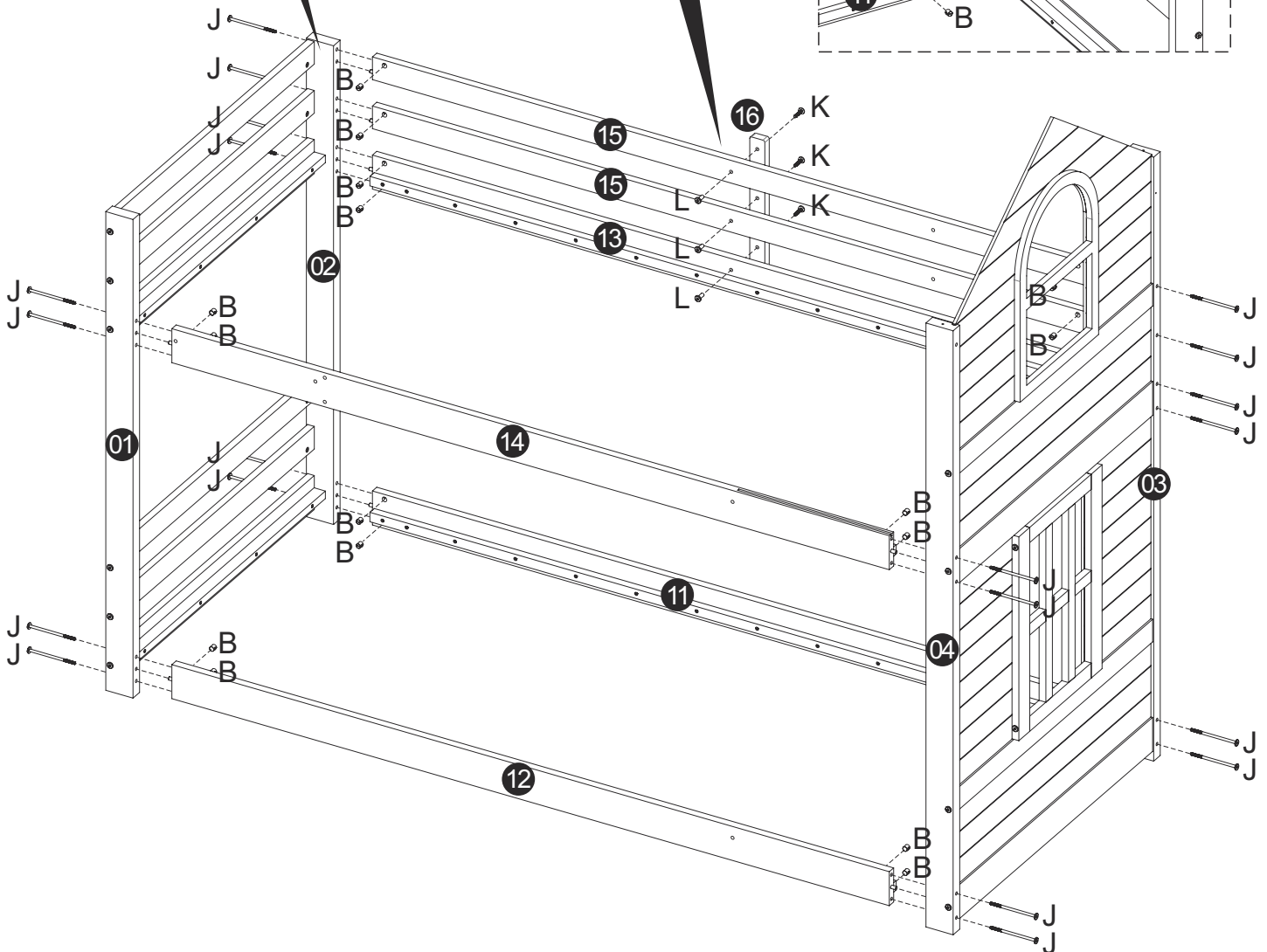
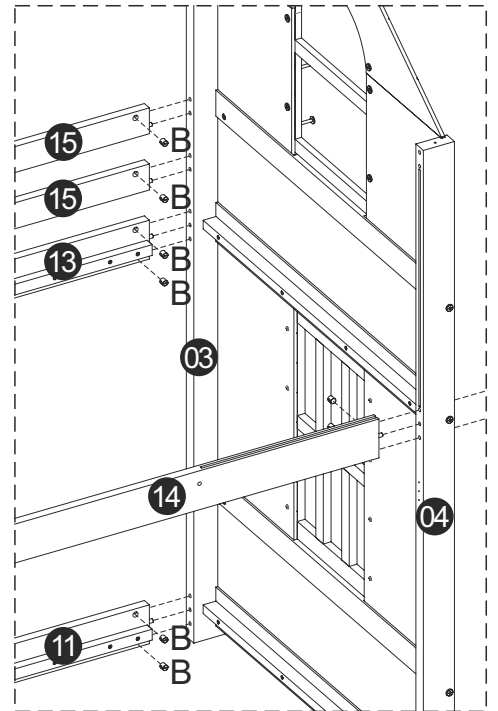
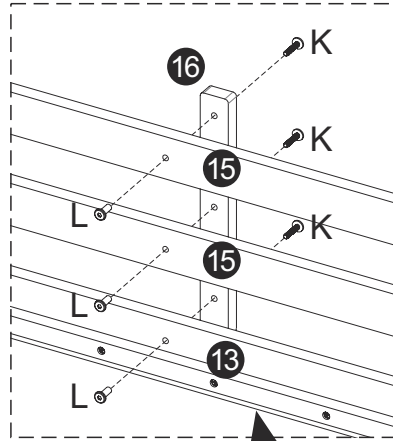
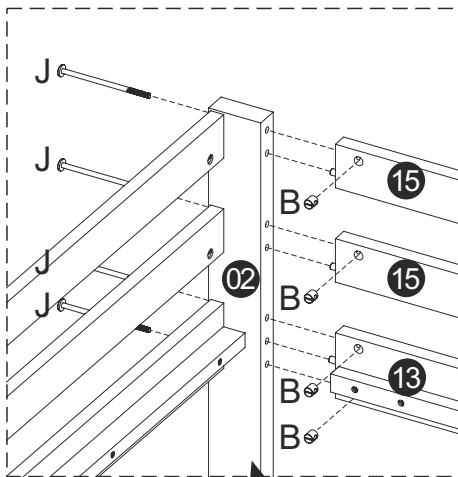

Schritt 10

B		20	K	 M6x30	3
J	 M6x120	20	L		3

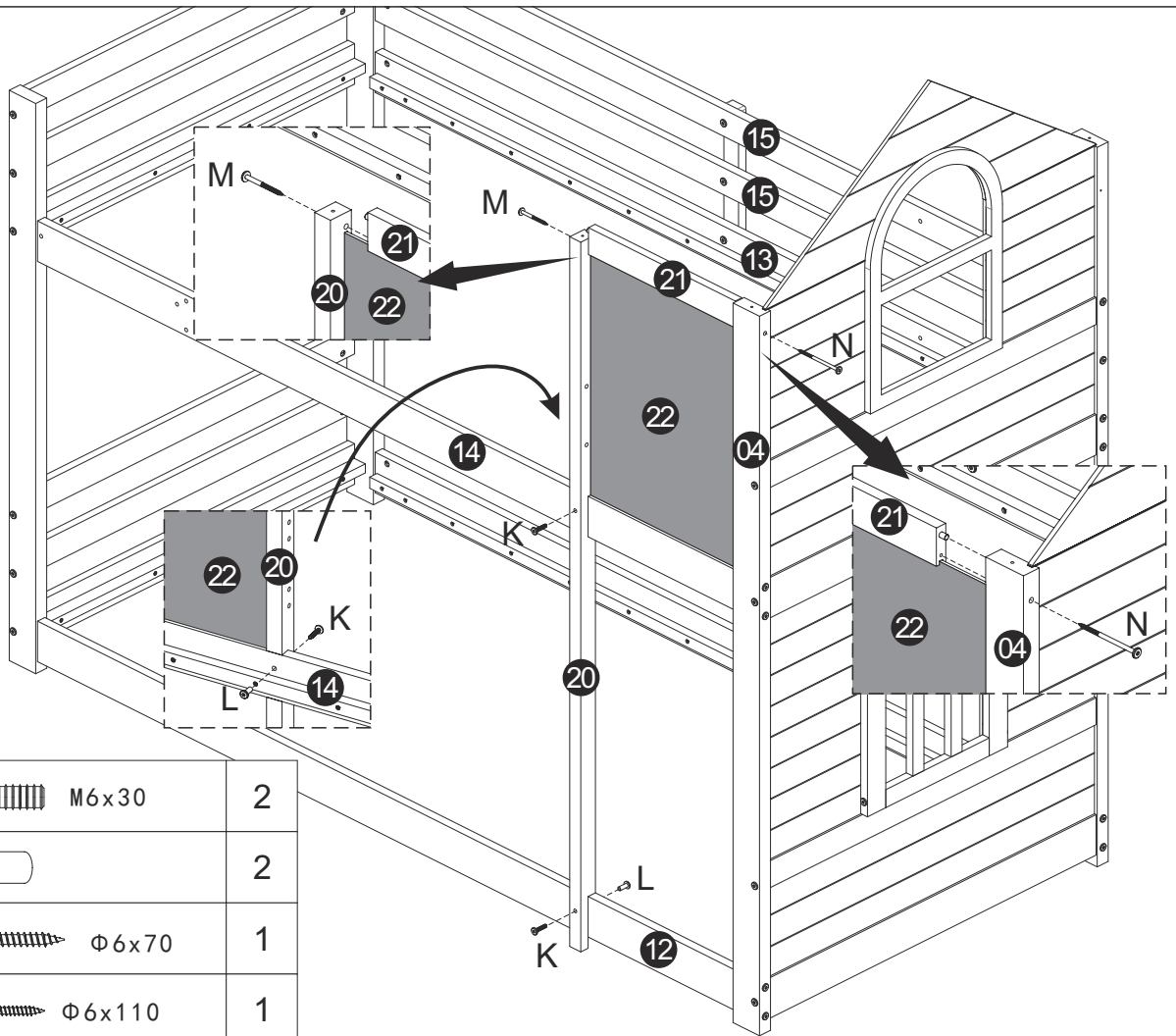



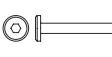

Schritt 11

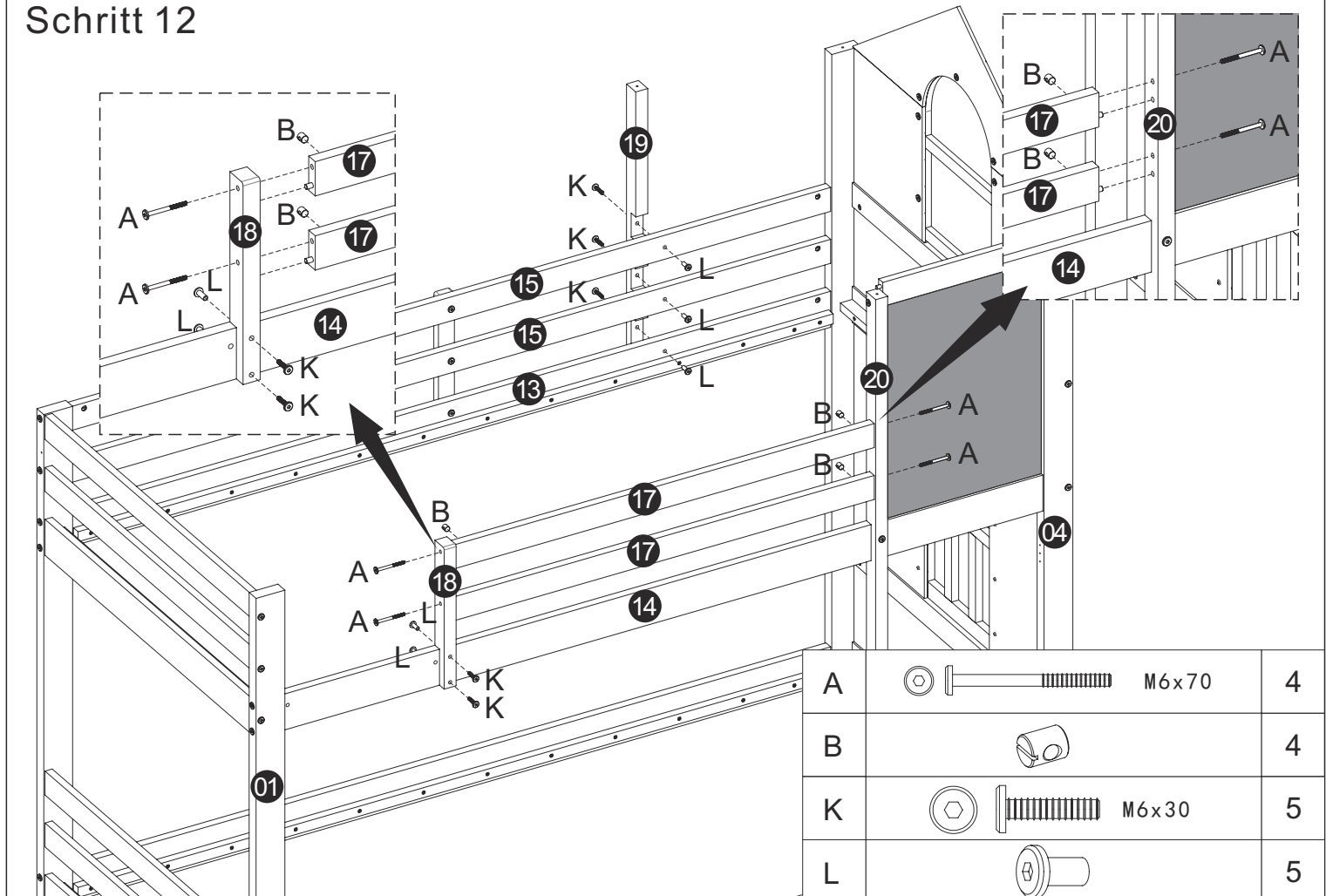

K	 M6x30	2
L		2
M	 $\Phi 6 \times 70$	1
N	 $\Phi 6 \times 110$	1

Schritt 12



A	 M6x70	4
B		4
K	 M6x30	5
L		5

Schritt 13

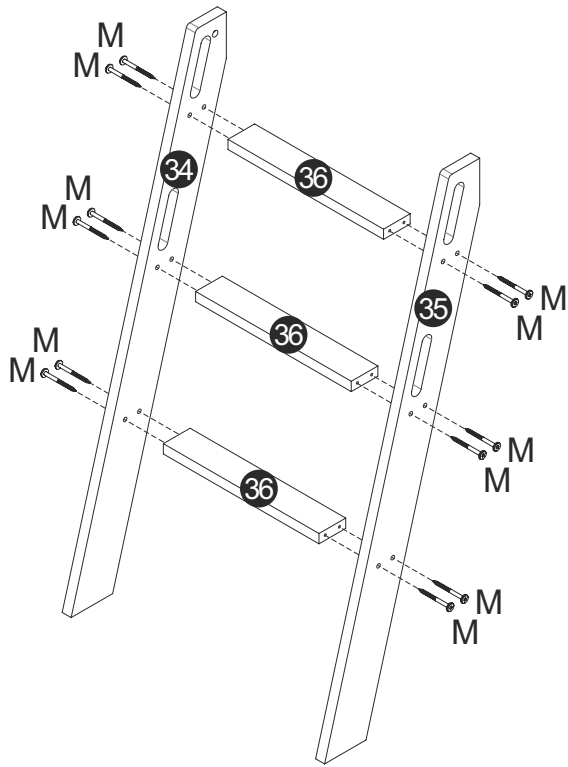

M



12

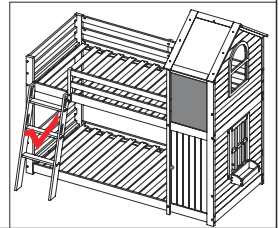

Schritt 14

B



2

P



2

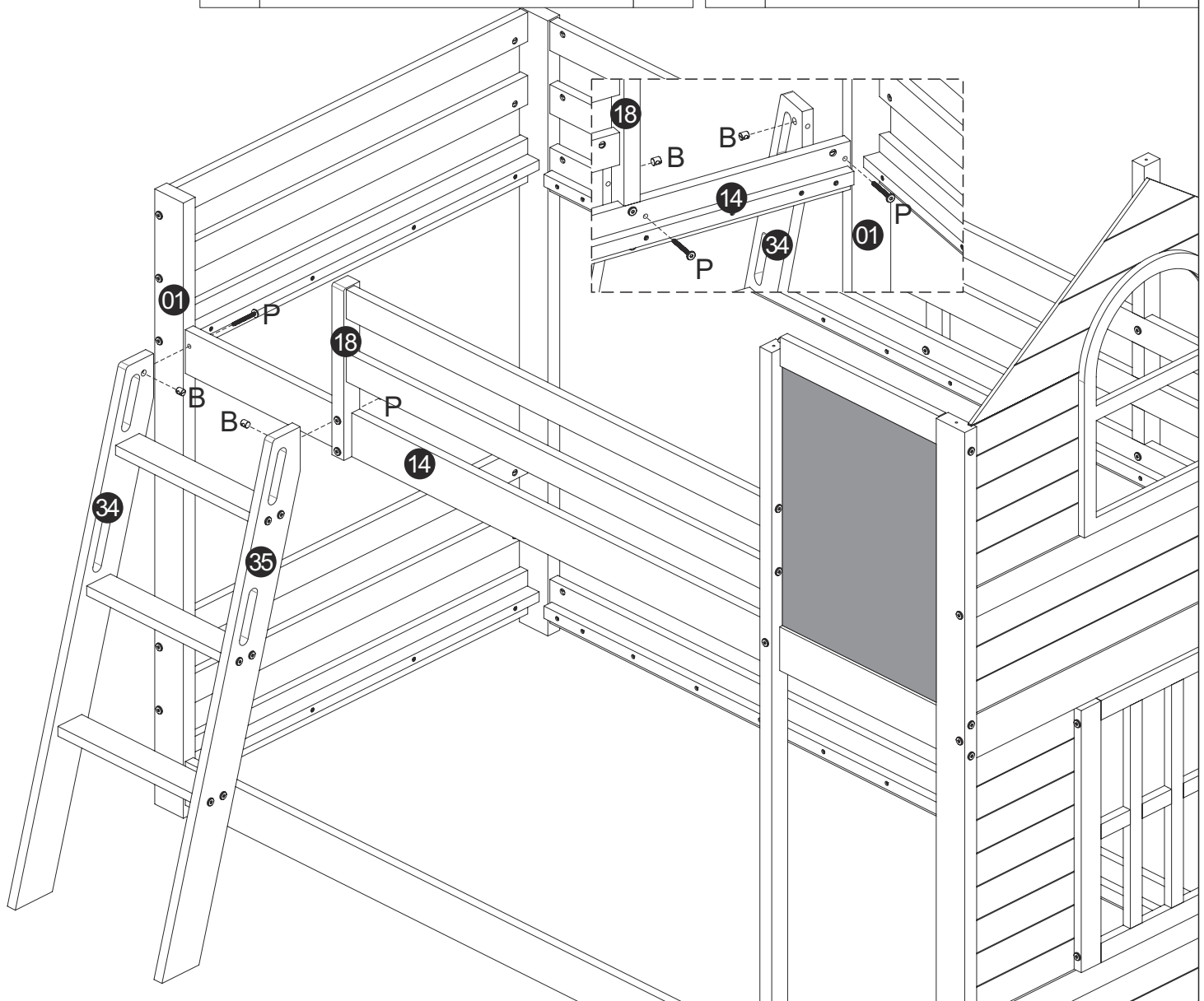

Schritt 15

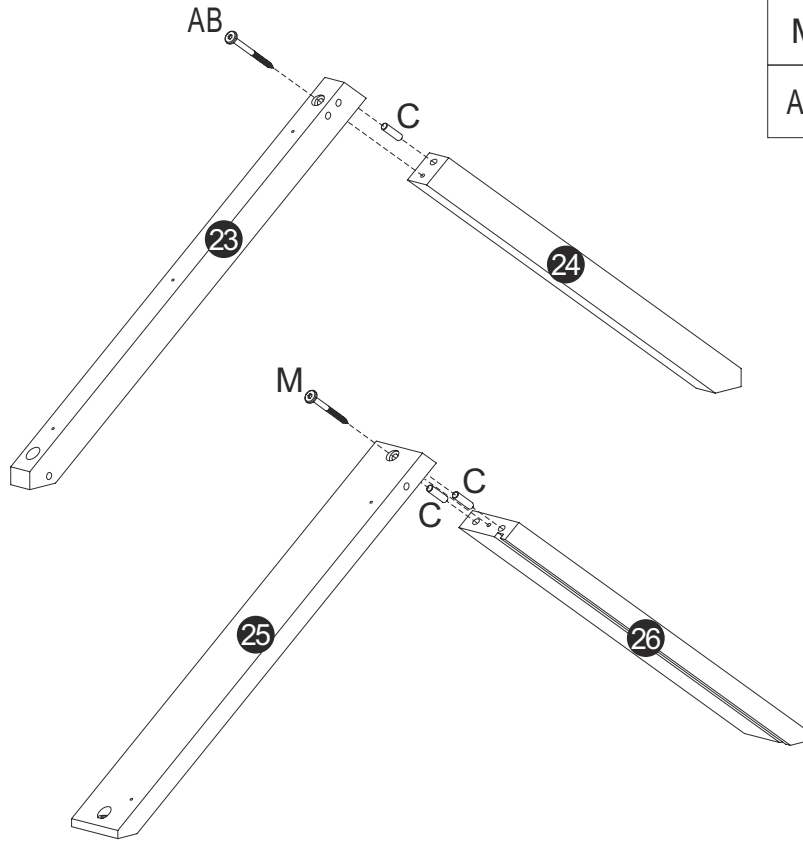

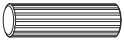
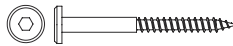
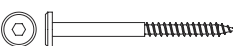
C		Φ8x30	3
M		Φ6x70	1
AB		Φ6x80	1

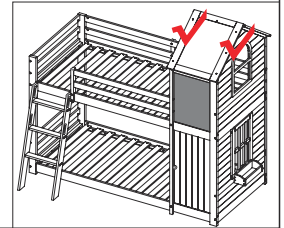

Schritt 16

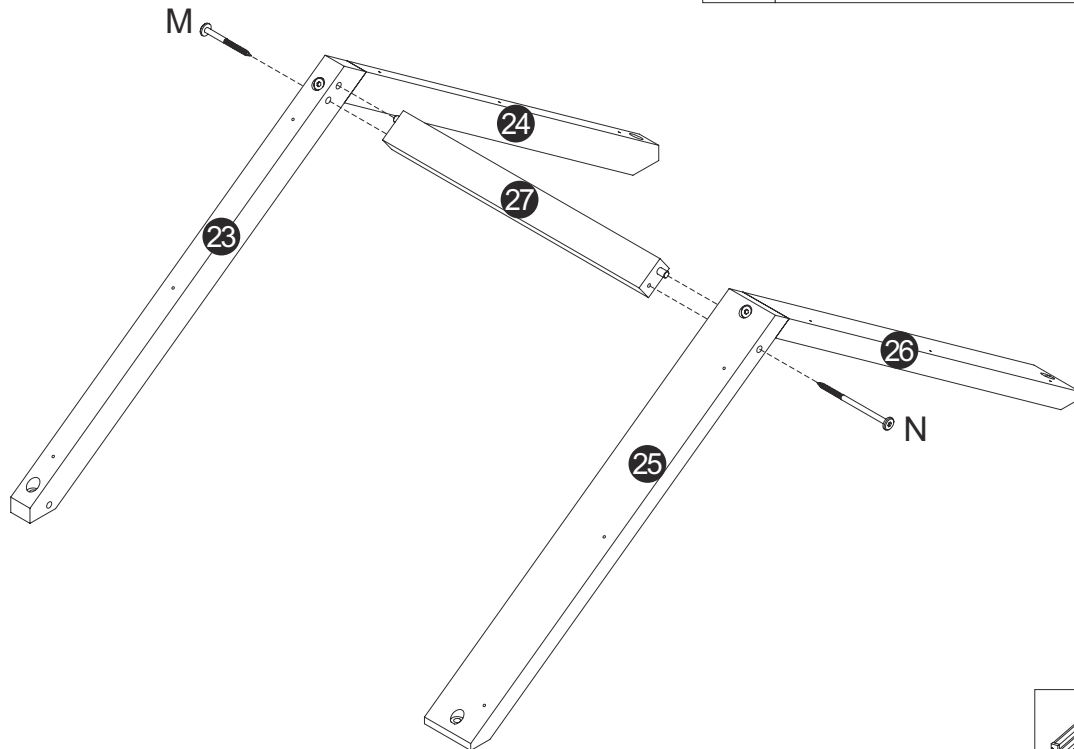

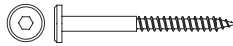
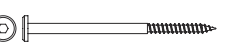
M		Φ6x70	1
N		Φ6x110	1

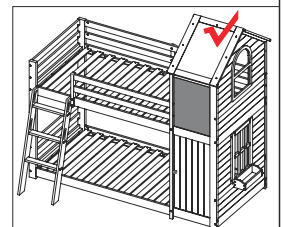

Schritt 17

M



2

Q



2

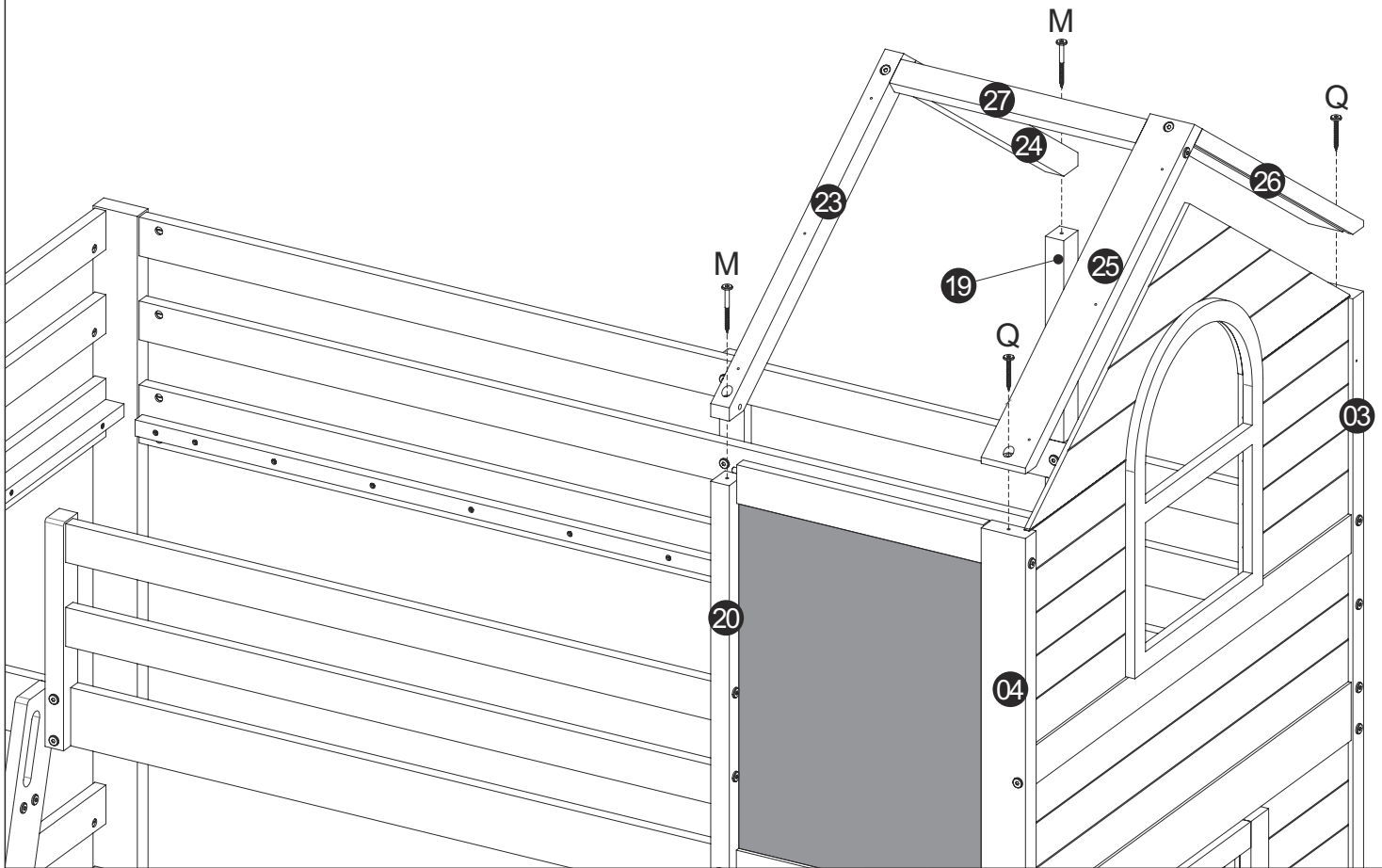

Schritt 18

C



8

N



8

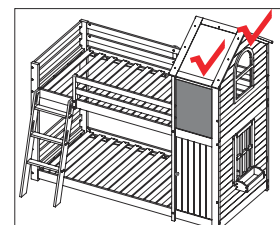
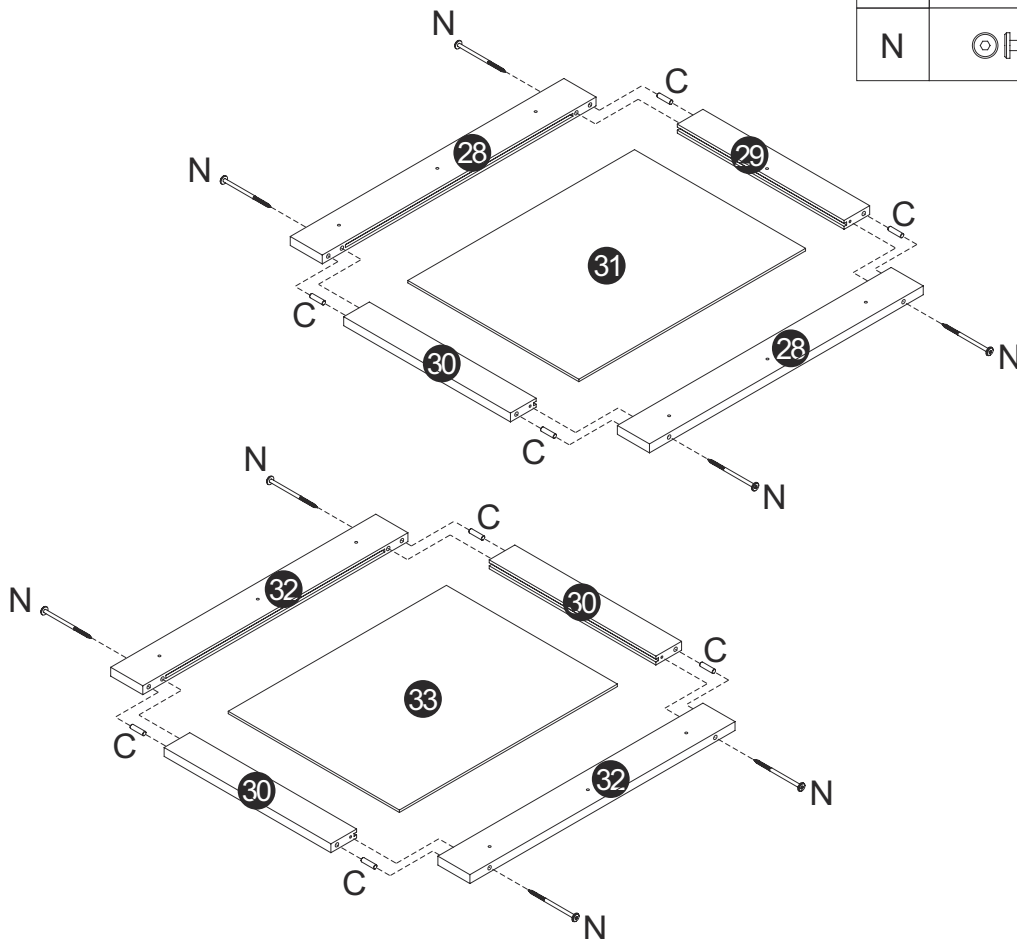

Schritt 19

R



13

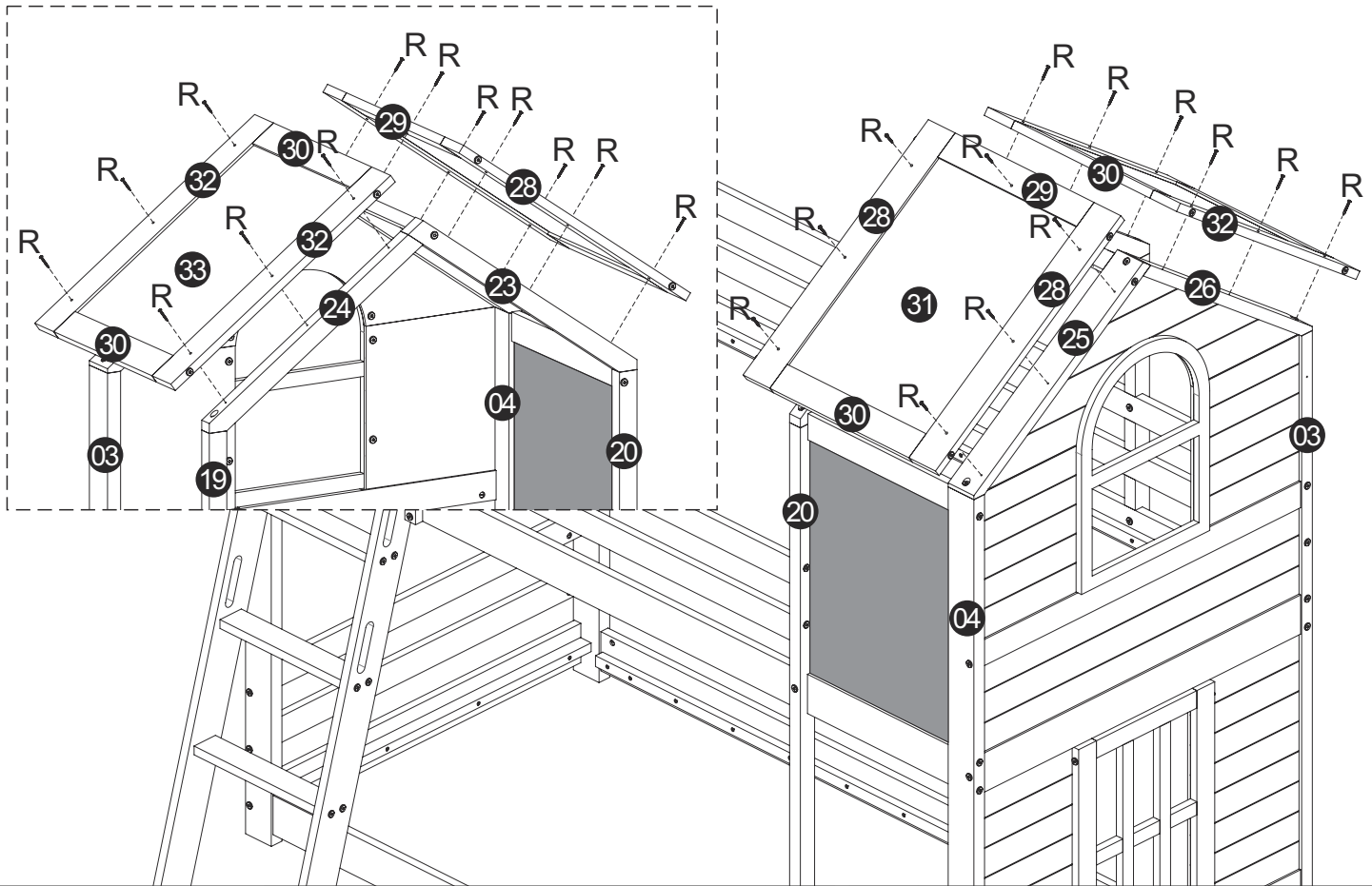

Schritt 20

S

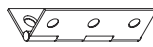

2

T

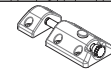

2

U



6

V



1

AC

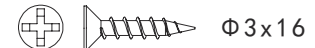

8

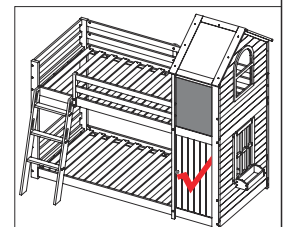
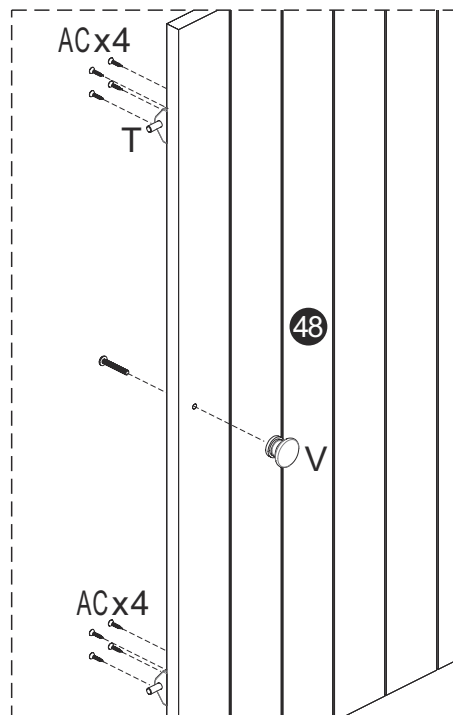
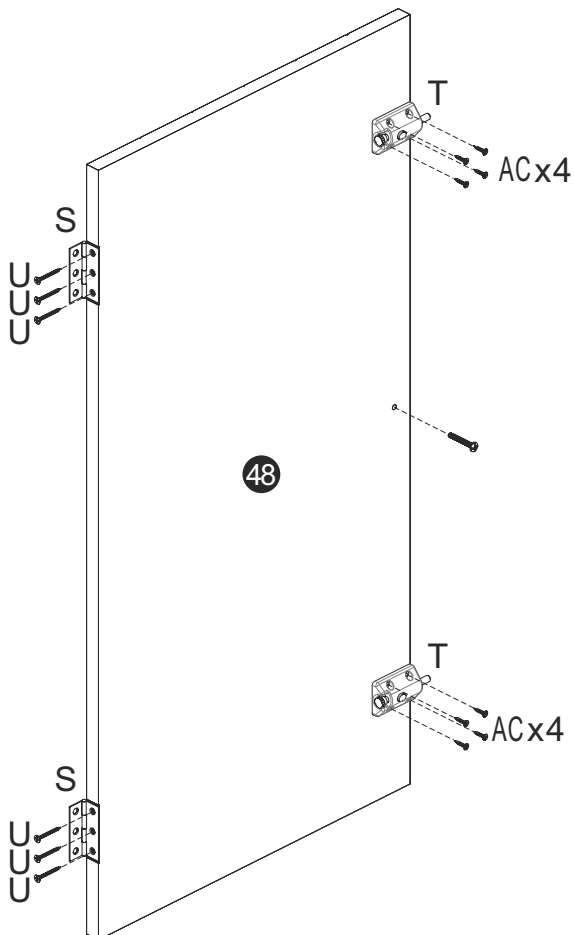

Schritt 21

T

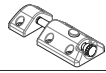

2

U



Φ 3x30

6

AC



Φ 3x16

4

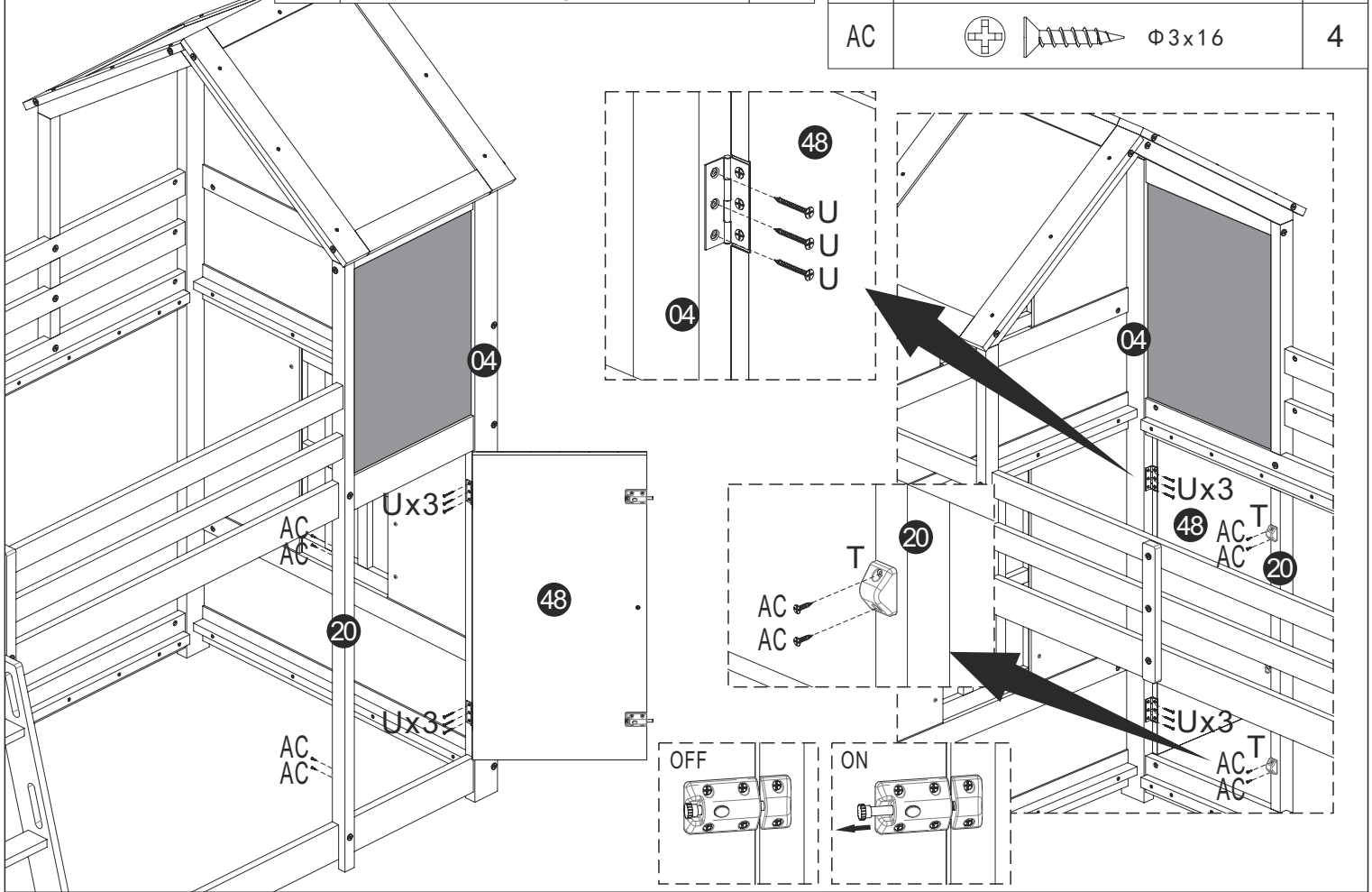

Schritt 22

U





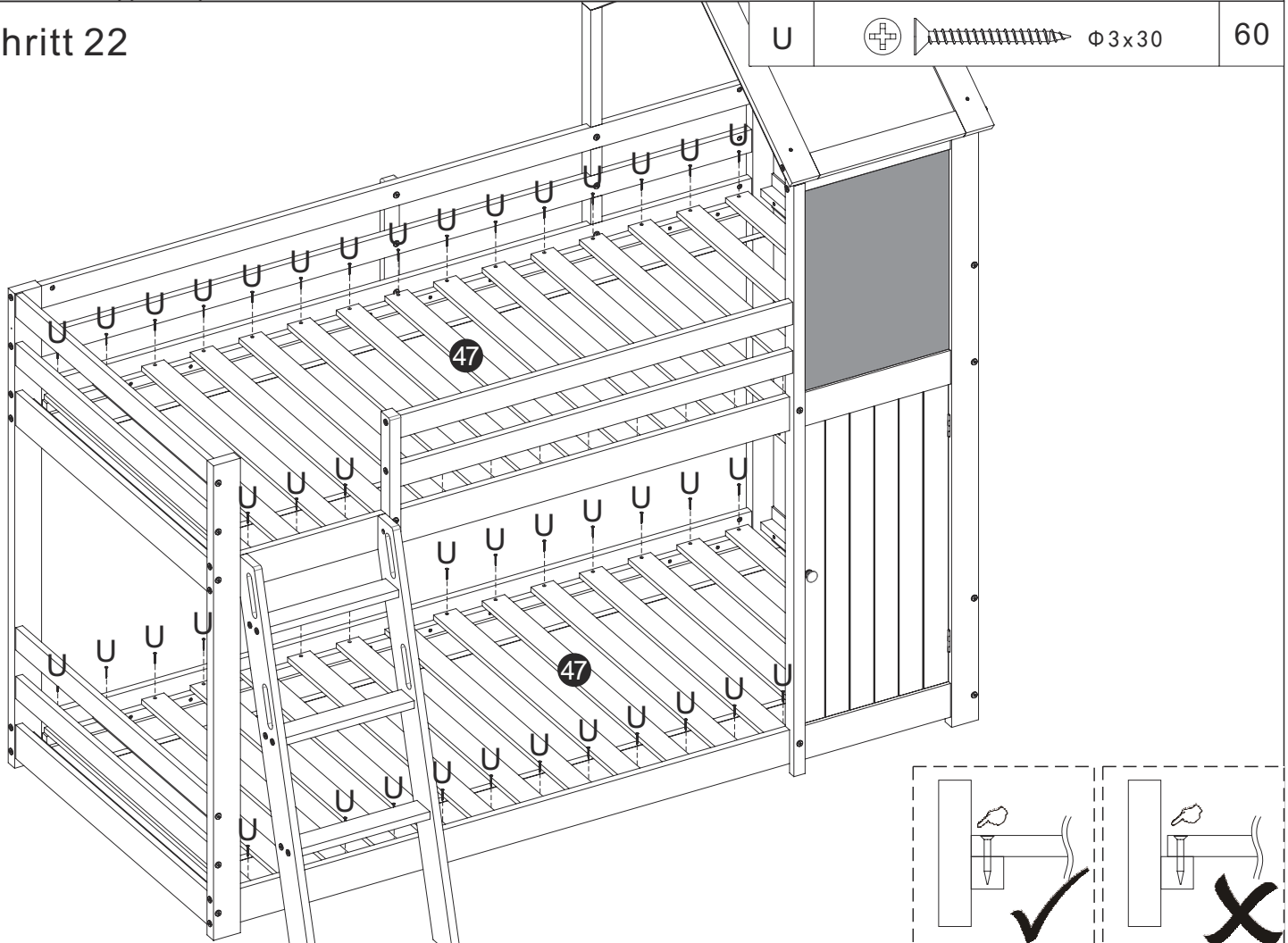

Φ 3x30

60



Schritt 23

D	 $\Phi 4 \times 40$	8	W		2
X	 $\Phi 3.5 \times 14$	4	X	 $\Phi 3.5 \times 14$	4

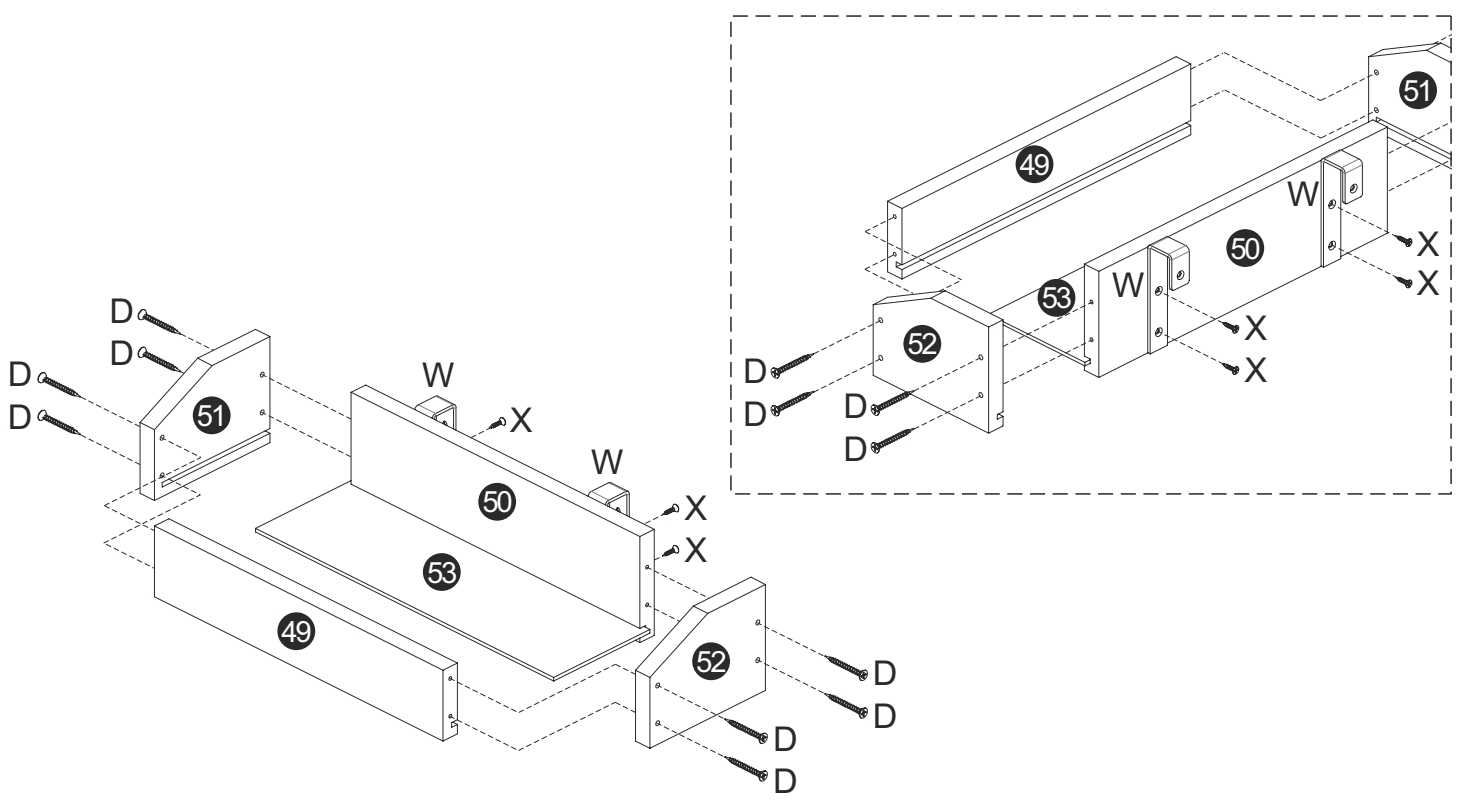

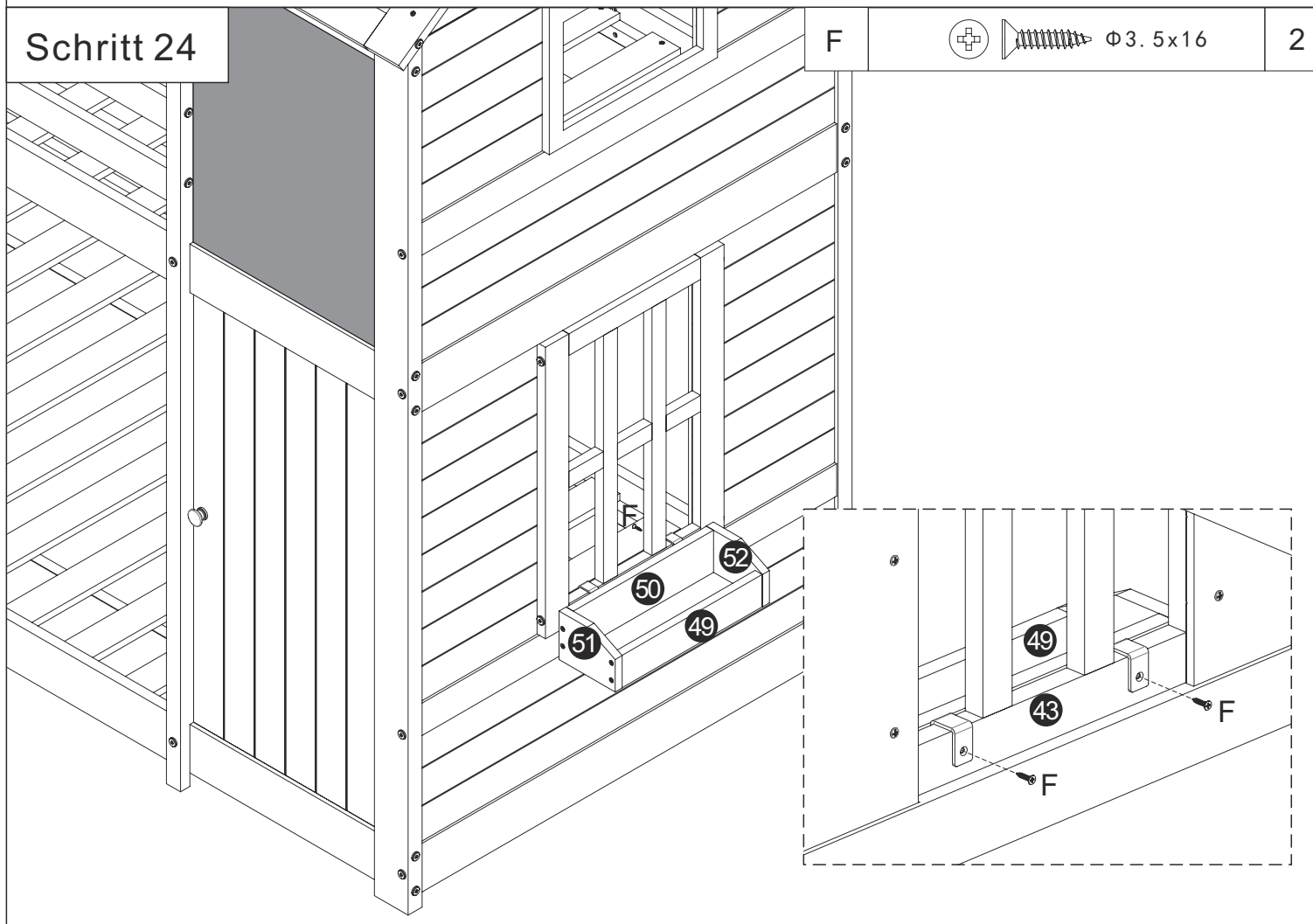

Schritt 24

F	 $\Phi 3.5 \times 16$	2
---	--	---

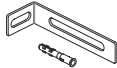

Schritt 25

Y		2
Z	  $\Phi 4 \times 30$	4

