

# GER-MAT6700

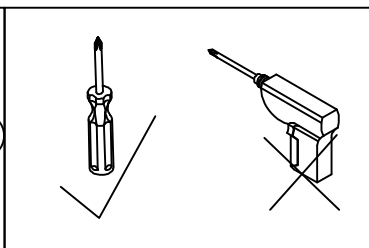
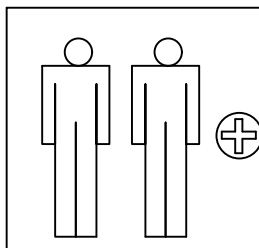
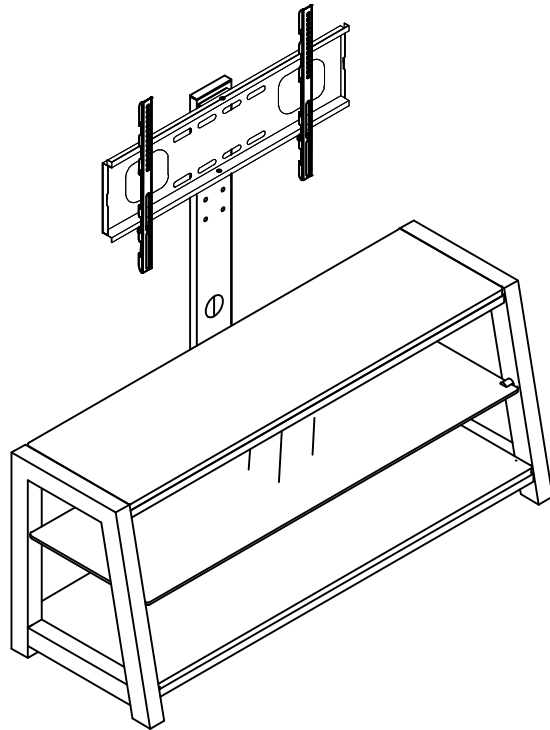

## EN\_Important Notes

1. Please inspect all components carefully before assembly.
2. During assembly, place the product on a soft, smooth surface (e.g., a carpet) to prevent scratching the parts.
3. Follow the assembly instructions in the correct sequence.
4. Do not fully tighten any screws until the product is completely assembled.
5. Returns are only accepted in the original packaging.  
(\*Assembled products are not eligible for return).

## FR\_Remarques importantes

1. Veuillez inspecter soigneusement tous les composants avant l'assemblage.
2. Lors de l'assemblage, placez le produit sur une surface lisse et molle (comme un tapis) pour éviter de rayer les pièces.
3. Suivez les instructions d'assemblage dans l'ordre indiqué.
4. Ne serrez aucune vis complètement avant que le produit ne soit entièrement assemblé.
5. Les retours ne sont acceptés que dans l'emballage d'origine.  
(\*Les produits assemblés ne peuvent pas être retournés).

## ES\_Notas importantes











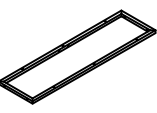
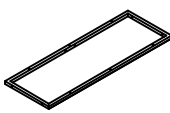
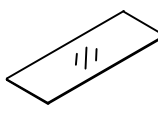

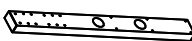

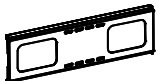

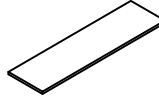
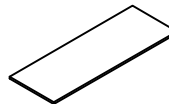
1. Inspeccione todos los componentes minuciosamente antes del montaje.
2. Durante el montaje, coloque el producto sobre una superficie lisa y blanda (por ejemplo, una alfombra) para evitar que se rayen las piezas.
3. Siga las instrucciones de montaje en el orden correcto.
4. No apriete por completo ningún tornillo hasta que el producto esté completamente montado.
5. Las devoluciones solo se aceptarán en el embalaje original.  
(\*No se admiten devoluciones de productos ya montados).

## DE\_Wichtige Hinweise

1. Bitte überprüfen Sie vor der Montage alle Komponenten sorgfältig..
2. Stellen Sie das Produkt während der Montage auf eine glatte, weiche Oberfläche (z. B. einen Teppich), um Kratzer an den Teilen zu vermeiden.
3. Befolgen Sie die Montageanleitung in der vorgegebenen Reihenfolge.
4. Ziehen Sie die Schrauben erst vollständig fest, wenn das Produkt vollständig montiert ist.
5. Rücksendungen sind nur in der Originalverpackung möglich.  
(\*Montierte Produkte können nicht zurückgegeben werden).

## IT\_Note importanti

1. Prima dell'assemblaggio, ispezionate attentamente tutti i componenti.
2. Durante l'assemblaggio, posizionate il prodotto su una superficie liscia e morbida (ad esempio, un tappeto) per evitare di graffiare le parti.
3. Seguire le istruzioni di assemblaggio nell'ordine corretto.
4. Non serrare completamente le viti prima che il prodotto sia completamente assemblato.
5. Le resi sono accettati solo nella confezione originale.  
(\*I prodotti assemblati non possono essere restituiti).

<b>1</b> x1 	<b>2</b> x1 	<b>3</b> x1 	<b>4</b> x1 
<b>5</b> x1 	<b>6</b> x1 	<b>7</b> x2 	<b>8</b> x1 
<b>9</b> x2 	<b>10</b> x1 	<b>11</b> x1 	
<b>A</b> x8 	<b>B</b> x4 	<b>C</b> x4 	<b>D</b> x4 
<b>E</b> x2 	<b>F</b> x2 	<b>G</b> x2 	<b>H</b> x12 
<b>I</b> x4 	<b>J</b> x4 		

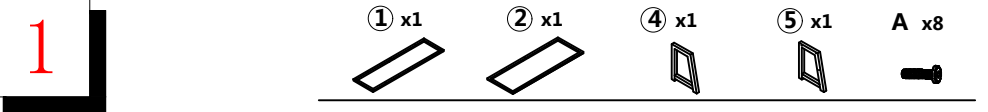

**1**

EN\_Do not fully tighten the screws until Step 4. This ensures that all screws are engaged in the correct holes and allows for the successful assembly of Parts 10 and 11.  
FR\_Ne serrez pas complètement les vis avant l'étape 4. Cela permet de vérifier que toutes les vis sont dans les bons trous et de procéder au montage correct des pièces 10 et 11.  
ES\_No apriete por completo los tornillos hasta el paso 4. Así se asegura de que todos los tornillos estén en los orificios correctos y de que las piezas 10 y 11 se monten correctamente.  
DE\_Bitte ziehen Sie die Schrauben erst in Schritt 4 vollständig fest, um sicherzustellen, dass alle Schrauben in den richtigen Löchern sitzen und die Teile 10/11 erfolgreich montiert werden können.  
IT\_Non serrare completamente le viti fino alla fase 4. In questo modo si garantisce che tutte le viti siano nei fori corretti e che le parti 10 e 11 possano essere montate correttamente.

EN\_Ensure the hole is on the back of component 1/2.  
FR\_Vérifiez que le trou est sur la face arrière de la pièce 1/2.  
ES\_Asegúrese de que el orificio esté en la parte trasera de la pieza 1/2.  
DE\_Stellen Sie sicher, dass sich das Loch auf der Rückseite von Teil 1/2 befindet.  
IT\_Assicurarsi che il foro si trovi sul lato posteriore del componente 1/2.

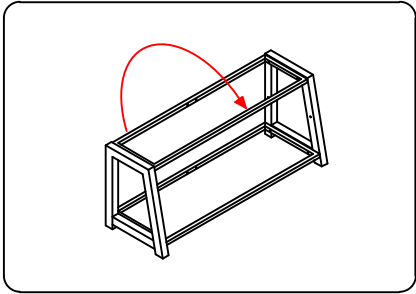
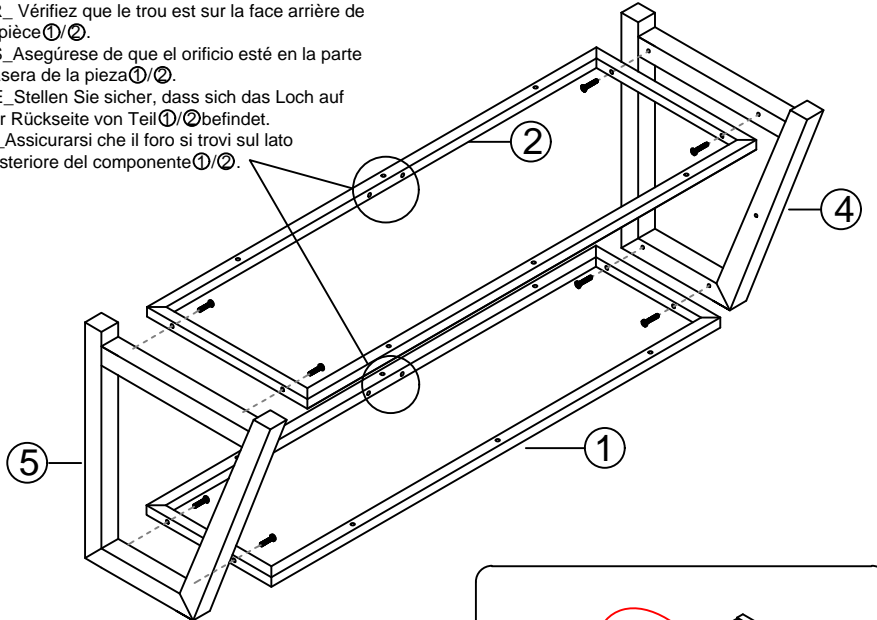

2

6 x1    B x4    I x2

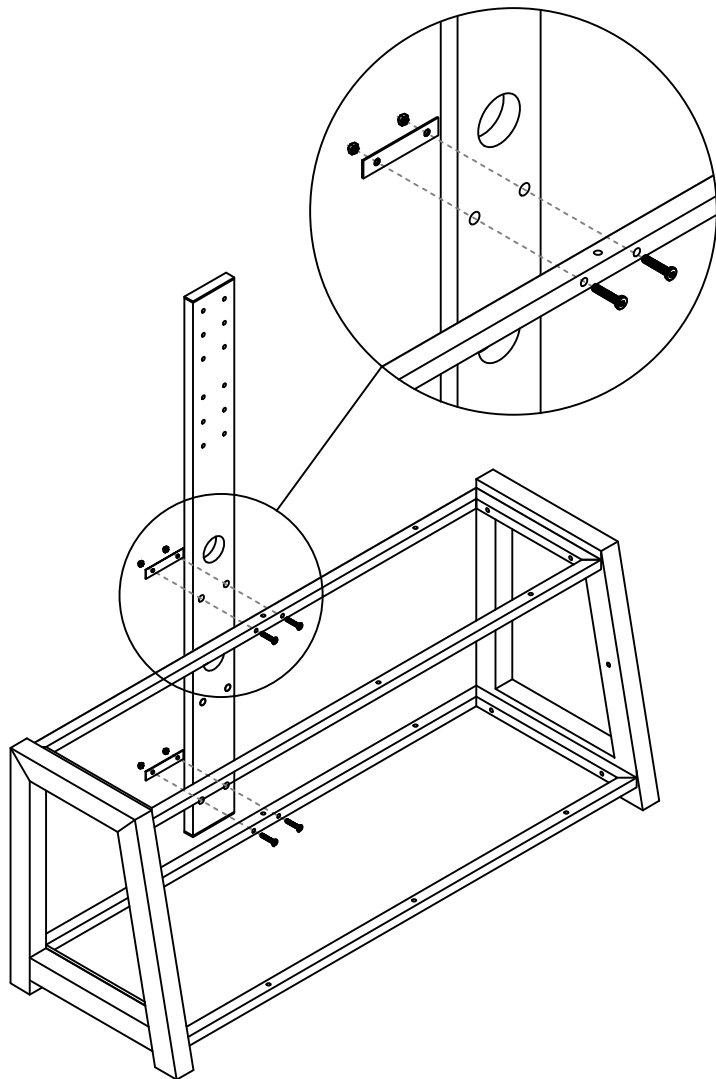

3

C x4

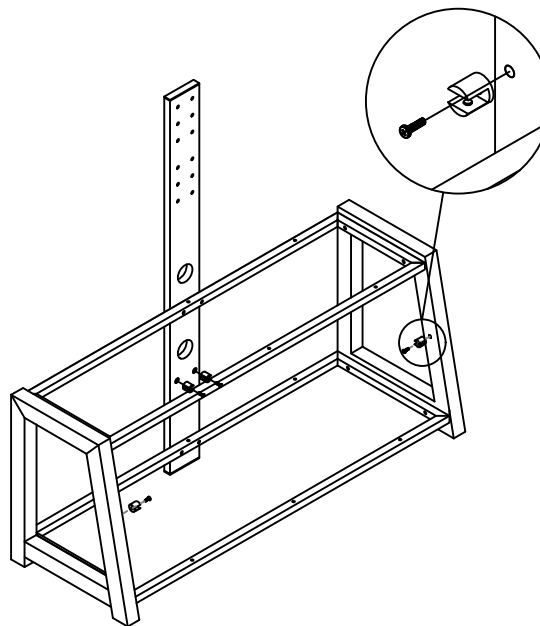

4

10 x1    11 x1    H x12

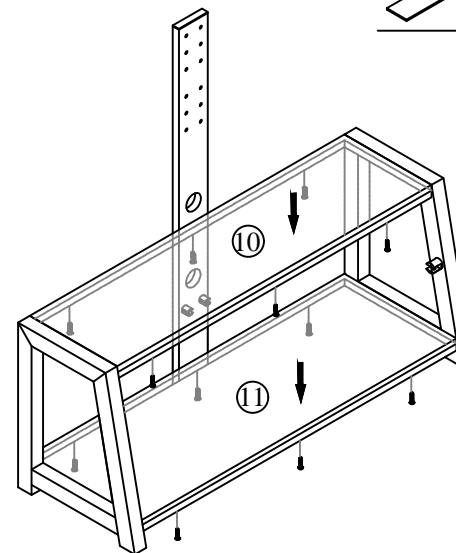
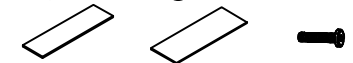

5

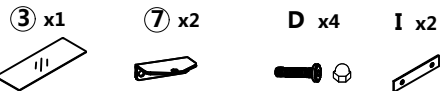

EN\_Please check and select the right height holes before assembling.  
 FR\_Veuillez vérifier et sélectionner les trous de hauteur appropriée avant l'assemblage.  
 ES\_Compruebe y seleccione los orificios de la altura adecuada antes del montaje.  
 DE\_Bitte überprüfen Sie vor dem Zusammenbau die richtigen Höhenlöcher und wählen Sie diese aus.  
 IT\_Controllerare e selezionare i fori dell'altezza corretta prima dell'assemblaggio.

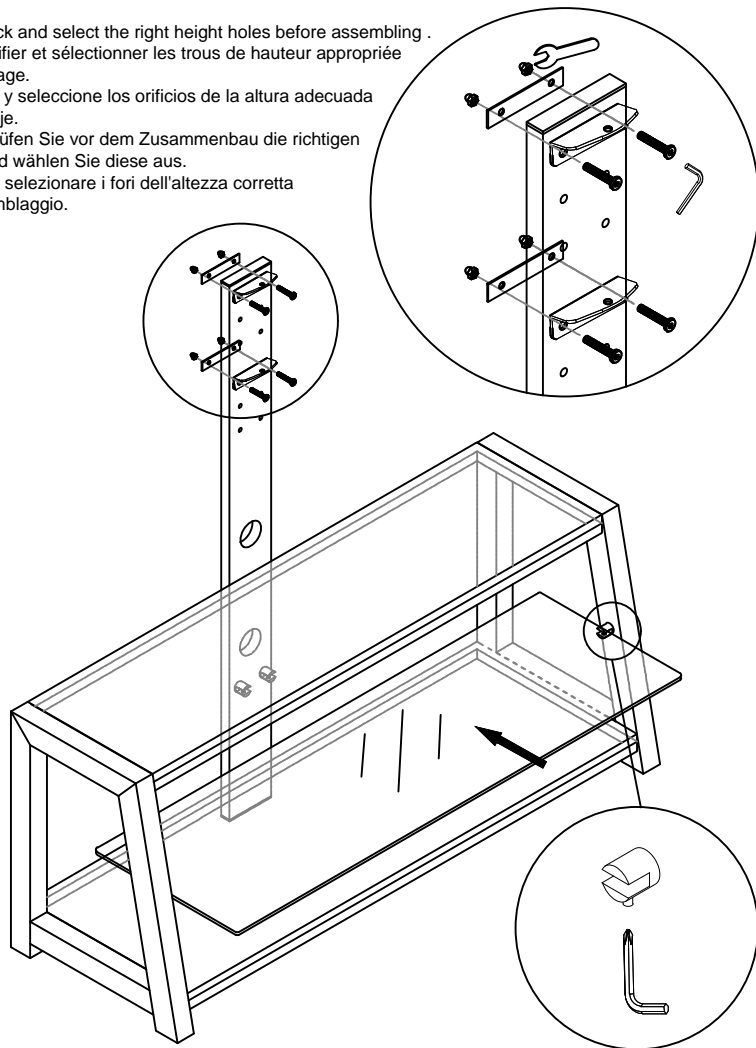

EN\_Fully tighten Part B after inserting the glass shelves.  
 FR\_Veuillez serrer complètement la partie B après avoir inséré les étagères en verre.  
 ES\_Apriete completamente la pieza B después de insertar los estantes de cristal.  
 DE\_Bitteziehen Sie Teil B nach dem Einsetzen der Glasböden vollständig fest.  
 IT\_Serrare completamente la parte B dopo aver inserito i ripiani in vetro.

6

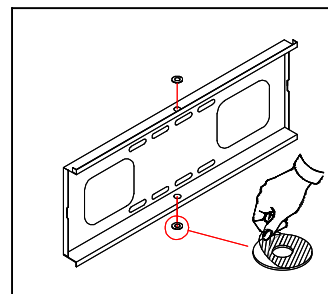

EN\_Attach one spacer above, and one below, the center hole on the steel frame.  
 FR\_Coller une entretoise au-dessus et une au-dessous du trou central du cadre en acier.  
 ES\_Pegar un espaciador arriba y otro abajo del orificio central del marco de acero.  
 DE\_Je einen Abstandhalter über und unter der mittleren Bohrung des Stahlrahmens anbringen.  
 IT\_Incollare un distanziatore sopra e uno sotto la foratura centrale del telaio in acciaio.

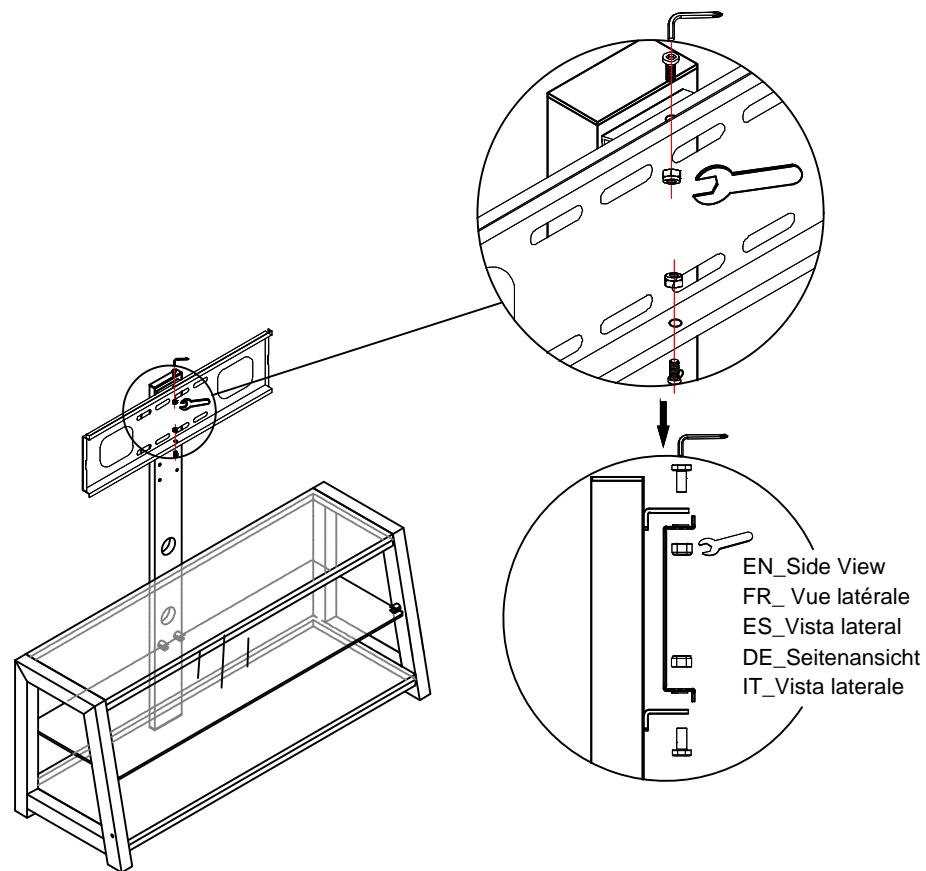

7

9 x2      F x2      G x2



EN\_Have your TV ready and position it before assembly.  
FR\_Ayez votre téléviseur à portée de main et placez-le avant l'assemblage.  
ES\_Tenga su televisor a mano y colóquelo antes del montaje.  
DE\_Halten Sie Ihren Fernseher bereit und positionieren Sie ihn vor dem Zusammenbau.  
IT\_Abbi la TV a portata di mano e posizionala prima dell'assemblaggio.

