

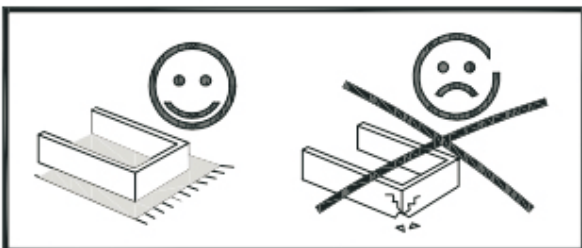

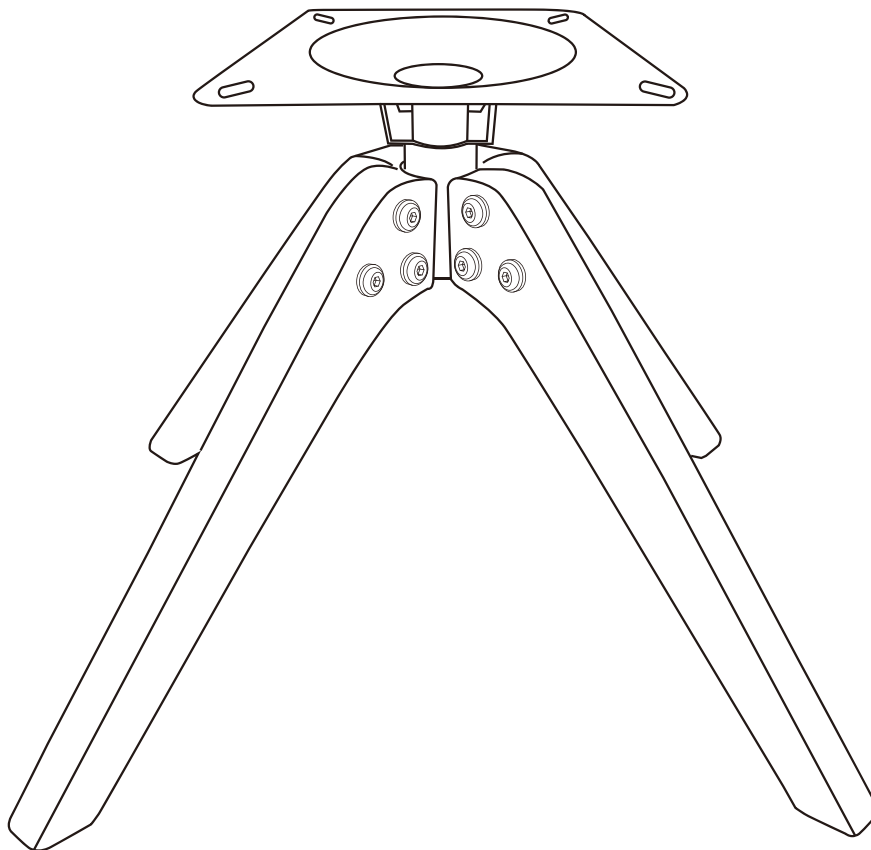

31101-B01-2

DUBI
Möbel

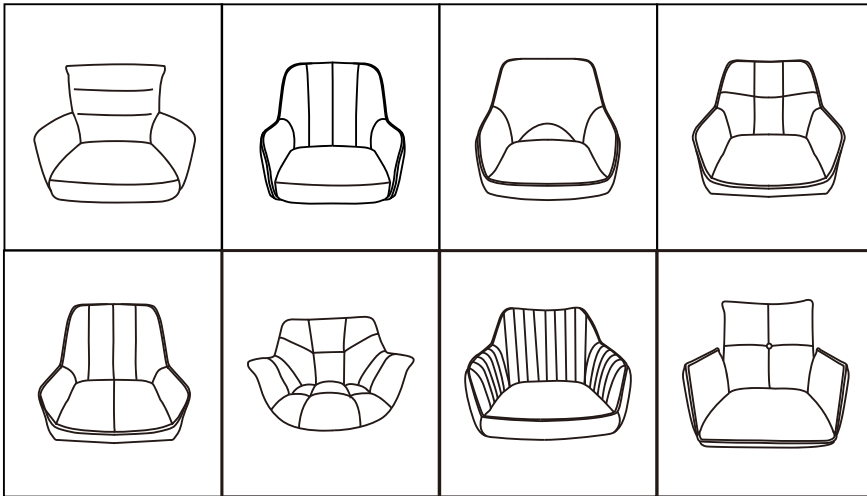
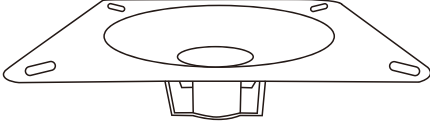
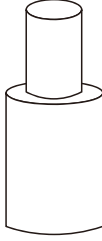
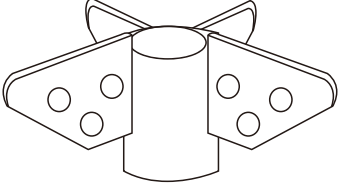
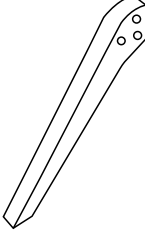
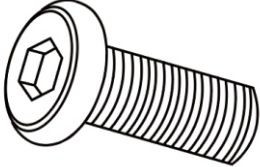
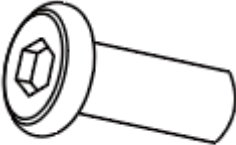
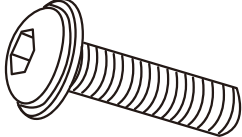
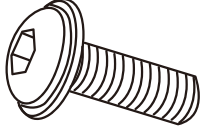
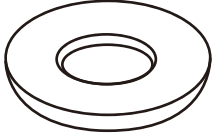
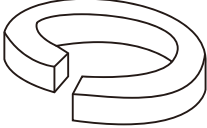

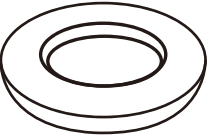



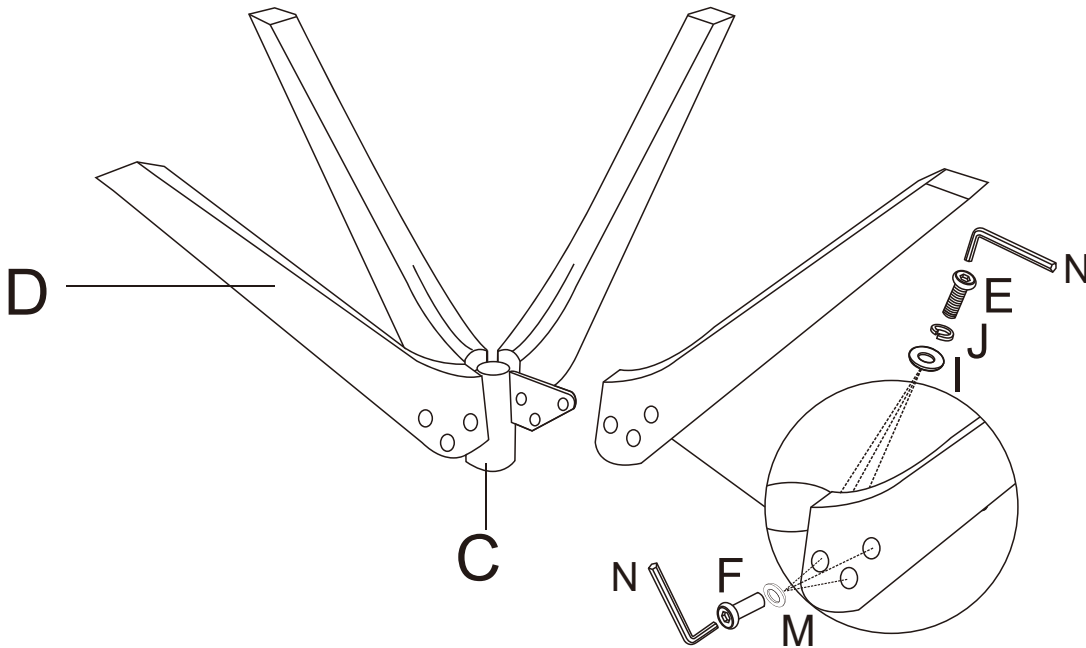

DUBI Möbel

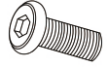
A  x1	B  x1	
C  x1	D  x4	
E  x12 M6x25mm	F  x12	
G  x2 M6x25mm	H  x2 M6x18mm	
I  x12	J  x12	
K  x4	L  x2	
M  x12	N  x2	O  x1

1



- 12x  E
- 12x  F
- 12x  I
- 12x  J
- 12x  M
- 2x  N

2

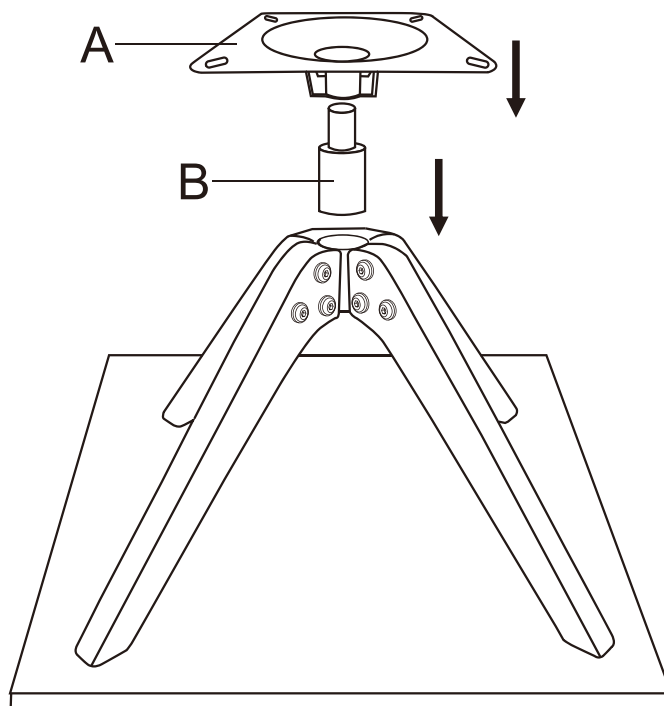

3

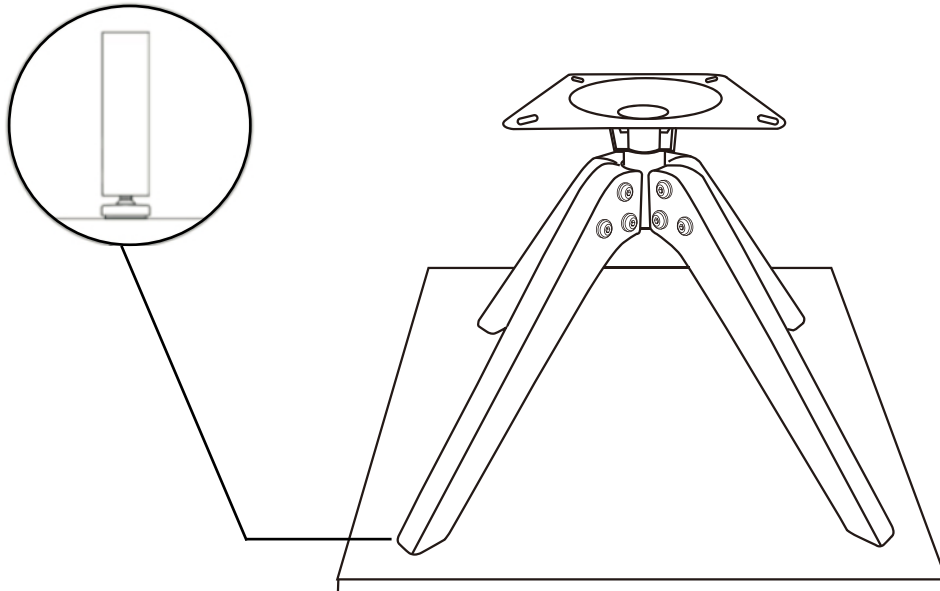

DE: Stabilitätshinweis

1. **Locker anziehen:** Alle Schrauben zuerst nur **ca. 80% festziehen** – Beine sollen noch beweglich sein.
2. **Ausrichten:** Stuhl auf **ebene Fläche** stellen, kurz auf die Sitzfläche drücken, bis **alle Beine fest aufliegen**.
3. **Festziehen:** Dann alle Schrauben **endgültig festziehen**, aber **nicht überdrehen**.

Pflege: Nach **4 Wochen** und dann **alle 6 Monate** Schrauben prüfen und ggf. nachziehen.

EN: Stability Notice





1. **Tighten loosely:** Tighten all screws only about **80%** at first – the legs should still be movable.
2. **Align:** Place the chair on a **flat, level surface**, press lightly on the seat until all legs are stable and touching the floor.
3. **Tighten fully:** Then tighten all screws **completely**, but **do not overtighten**.

Maintenance: Check and retighten screws **after 4 weeks** and then **every 6 months**.

FR: Avis de stabilité

1. **Serrer légèrement:** Serrez d'abord toutes les vis à environ **80%** – les pieds doivent rester légèrement mobiles.
2. **Ajuster:** Placez la chaise sur une **surface plane et stable**, appuyez légèrement sur l'assise jusqu'à ce que les quatre pieds reposent bien au sol.
3. **Serrer complètement:** Serrez ensuite toutes les vis **à fond**, mais **sans forcer**.

Entretien: Vérifiez et resserrez les vis **après 4 semaines**, puis **tous les 6 mois**.

- 2x G 
- 2x H 
- 4x K 
- 2x L 
- 1x O 

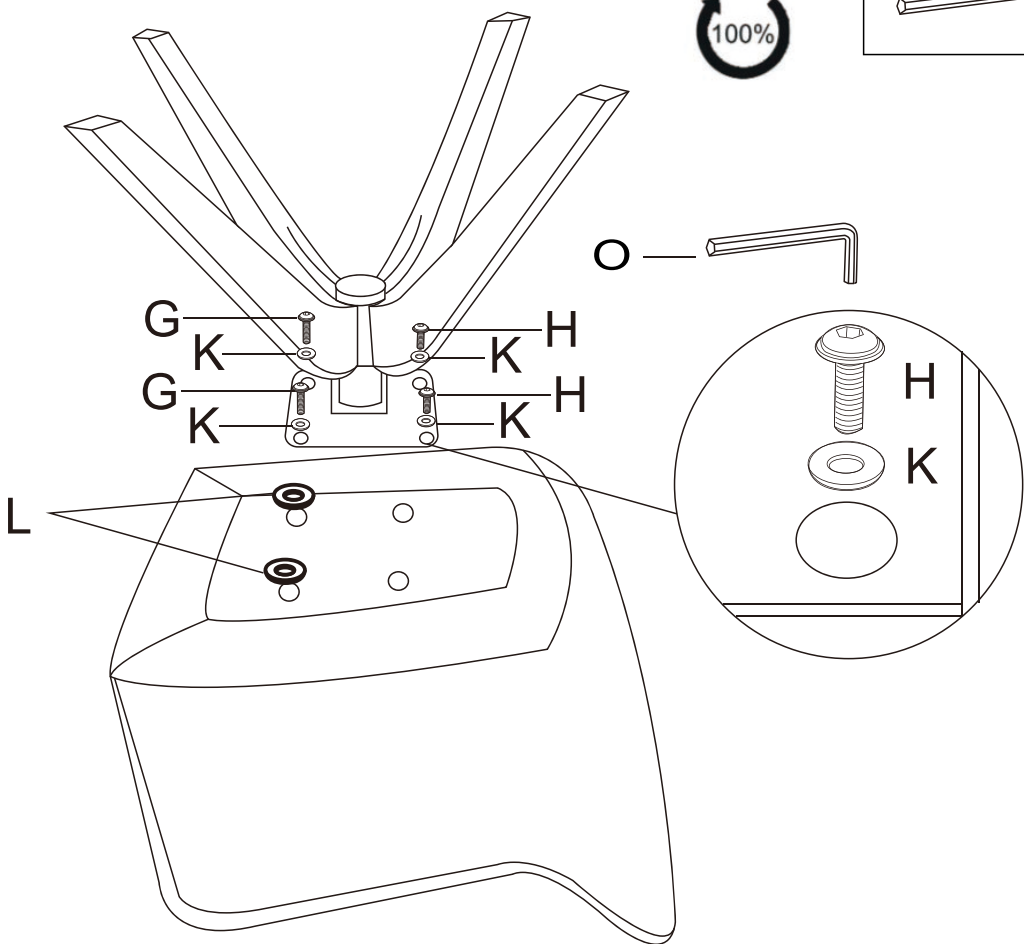

5

