

Installation sanleitung Installation Instruction Instruction d'installation

Eisenbett

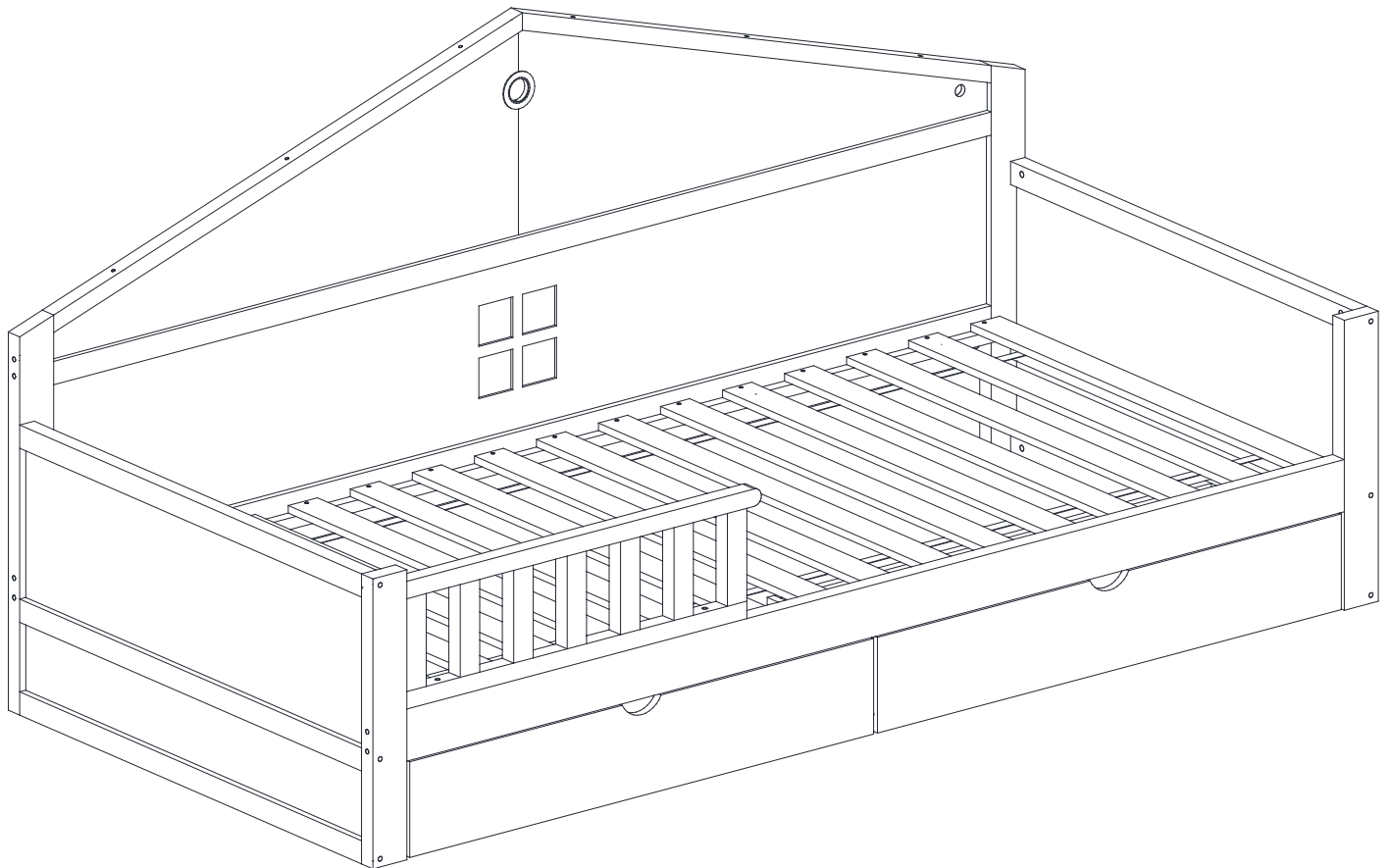

DE: Unser Produkt wird Ihnen in 2 Paketen geliefert. Die Lieferzeiten dieser 2 Pakete können abweichen, bitte haben Sie etwas Geduld und vielen Dank für Ihr Verständnis.

UK: Our product will be delivered to you in 2 packages. The delivery times of these 2 packages may differ, please be patient and thank you for your understanding.

FR: Notre produit vous sera livré en 2 colis. Les délais de livraison de ces 2 colis peuvent différer, soyez patient et merci pour votre compréhension.

N623P371628/N623P371629

INSTRUCTIONS

IMPORTANT-READ CAREFULLY-RETAIN FOR FUTURE REFERENCE

- a) **WARNING** -Children can become trapped between the bed and the wall, the adjoining pieces of furniture (e.g. cupboards) and the like. To avoid risk of serious injury the distance between the safety barrier and the adjoining structure shall not exceed 75 mm or shall be more than 230 mm.
- b) **WARNING**-Do not use the bed if any structural part is broken or missing; Replacement parts are between requested from the manufacturer or the store.
- c) **WARNING**-Do not climb or wiggle on any non-designated structures.
- d) it is imperative to always follow the installation instructions and manufacturer's use.
- e) The recommended size of the mattress to be used with the bed is 200cmx90cm, maximum thickness mattress:12cm.
- f) It is necessary to ventilate the room in order to maintain a low level moisture and prevent mold growth in the bed and its periphery.
- g) Joining devices should always be tightened properly and regularly verified. Tighten if necessary.

ANLEITUNGEN

WICHTIG - SORGFÄLTIG LESEN - FÜR SPÄTERE VERWENDUNG

AUFBEWAHREN

- a) **WARNUNG** - Kinder können zwischen dem Bett und der Wand, den angrenzenden Möbelstücken (z. B. Schränken) und der Lücke eingeklemmt werden. Um die Gefahr schwerer Verletzungen zu vermeiden, darf der Abstand zwischen der Sicherheitsbarriere und der angrenzenden Struktur nicht mehr als 75 mm oder mehr als 230 mm betragen.
- b) **WARNUNG**-Das Bett darf nicht benutzt werden, wenn ein Bauteil gebrochen ist oder fehlt; Ersatzteile sind beim Hersteller oder im Geschäft anzufordern.
- c) **WARNUNG** - Klettern oder wackeln Sie nicht auf nicht dafür vorgesehenen Strukturen.
- d) Befolgen Sie unbedingt die Installationsanweisungen und die Gebrauchsanweisungen des Herstellers.
- e) Die empfohlene Größe der Matratze für das Bett beträgt 200x90cm, maximale Dicke der Matratze: 12cm.
- f) Es ist notwendig, den Raum zu lüften, um die Feuchtigkeit niedrig zu halten und Schimmelbildung im Bett und seiner Umgebung zu verhindern.
- g) Die Verbindungselemente sollten immer richtig angezogen sein und regelmäßig überprüft werden. Ziehen Sie sie gegebenenfalls nach.

English

IMPORTANT ! KEEP FOR FUTURE REFERENCE : READ CAREFULLY

- To be assembled by an adult. Assembly must be checked by an adult before use
 - WARNING ! Keep all screws, small parts and plastic bags out of the reach of children
 - Properly identify all parts before assembling
 - Never use your item if any of its parts are broken or missing
 - Should any problems arise, please contact our After Sales Service
 - Manufacturer's instructions shall be followed at all times
 - Care: Clean with a soft, dry cloth. In case of larger stains, carefully rub with a slightly damp, non-abrasive sponge
 - Avoid the risk of fire by not placing furniture near sources of ignition or hot items
- Do not jump on the bed

Deutsch

WICHTIG ! ZUM SPÄTEREN NACHSCHLAGEN AUFBEWAHREN: SORGFÄLTIG LESEN

- Muss von einem Erwachsenen zusammengebaut werden. Der Zusammenbau muss vor dem Gebrauch von einem Erwachsenen überprüft werden
 - WARNUNG! Bewahren Sie alle Schrauben, Kleinteile und Plastikbeutel außerhalb der Reichweite von Kindern auf
 - Kennzeichnen Sie vor dem Zusammenbau alle Teile richtig
 - Benutzen Sie Ihren Artikel niemals, wenn Teile gebrochen sind oder fehlen
 - Sollten Probleme auftreten, wenden Sie sich bitte an unseren Kundendienst
 - Die Anweisungen des Herstellers sind stets zu befolgen
 - Pflege: Mit einem weichen, trockenen Tuch reinigen. Bei größeren Flecken vorsichtig mit einem leicht feuchten, nicht scheuernden Schwamm abreiben. nicht scheuernden Schwamm
 - Vermeiden Sie die Gefahr eines Brandes, indem Sie die Möbel nicht in der Nähe von Zündquellen oder heißen Gegenständen aufstellen
- Nicht auf das Bett springen

Français

IMPORTANT ! CONSERVER POUR RÉFÉRENCE ULTÉRIEURE : LIRE ATTENTIVEMENT

- Le montage doit être effectué par un adulte. Le montage doit être vérifié par un adulte avant Utilisation
 - ATTENTION ! Tenir les vis, les petites pièces et les sachets en plastique hors de portée des enfants
 - Identifiez correctement toutes les pièces avant de les assembler
 - N'utilisez jamais votre article si l'une de ses pièces est cassée ou manquante
 - En cas de problème, veuillez contacter notre service après-vente
 - Les instructions du fabricant doivent être respectées à tout moment
 - Entretien : nettoyer avec un chiffon doux et sec. En cas de taches plus importantes, frotter soigneusement avec une éponge non abrasive légèrement humide. légèrement humide et non Abrasive
 - Évitez les risques d'incendie en ne plaçant pas les meubles à proximité de sources d'inflammation ou d'objets chauds
- Ne pas sauter sur le lit

Italiano

IMPORTANTE! CONSERVARE PER RIFERIMENTO FUTURO: LEGGERE ATTENTAMENTE

- Deve essere assemblato da un adulto. L'assemblaggio deve essere controllato da un adulto prima dell'uso
- **ATTENZIONE!** Tenere tutte le viti, le piccole parti e i sacchetti di plastica fuori dalla portata dei bambini
- Identificare correttamente tutte le parti prima dell'assemblaggio
- Non utilizzare mai l'articolo se alcune parti sono rotte o mancanti
- In caso di problemi, si prega di contattare il nostro Servizio Post Vendita
- Le istruzioni del produttore devono essere sempre seguite
- Cura: Pulire con un panno morbido e asciutto. In caso di macchie più estese, strofinare accuratamente con una spugna leggermente umida e nonspugna leggermente umida e non abrasiva
- Evitare il rischio di incendio, non collocando i mobili vicino a fonti di accensione o a oggetti caldi
- Non saltare sul letto

Español

¡ IMPORTANTE ! CONSERVELO PARA FUTURAS CONSULTAS: LEA ATENTAMENTE

- Debe ser montado por un adulto. El montaje debe ser comprobado por un adulto antes del uso
- ADVERTENCIA** Mantenga todos los tornillos, piezas pequeñas y bolsas de plástico fuera del alcance de los niños.
- Identifique correctamente todas las piezas antes de montarlas
 - Nunca utilice su artículo si alguna de sus piezas está rota o falta
 - Si surge algún problema, póngase en contacto con nuestro Servicio Postventa
 - Las instrucciones del fabricante deben seguirse en todo momento
 - Cuidado: Limpiar con un paño suave y seco. En caso de manchas más grandes, frote cuidadosamente con una esponja no abrasiva ligeramente humedecida.
 - Evite el riesgo de incendio no colocando los muebles cerca de fuentes de ignición u objetos calientes.
 - No saltar sobre la cama.

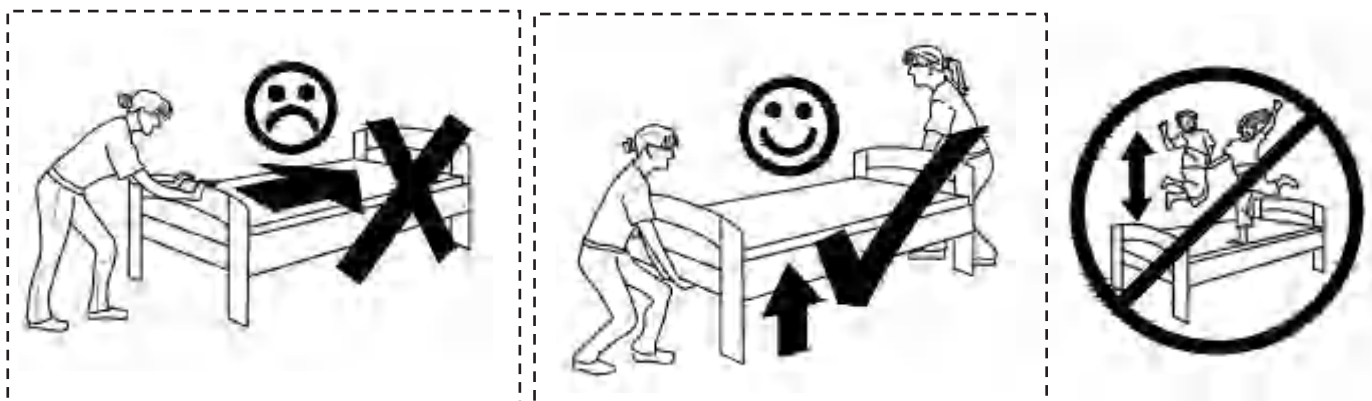

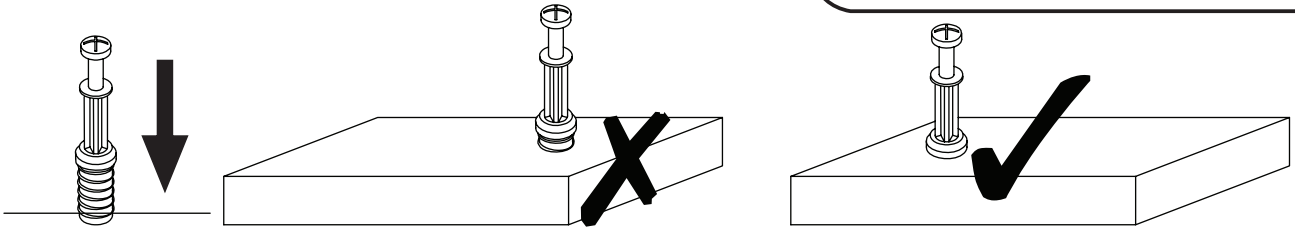

EN_QUICKFIT: Tighten quickfit until shoulder is flush with panel. Do not overtighten or undertighten.

FR_RACCORD RAPIDE: Faites serrer le raccord rapide jusqu'à ce que l'épaulement soit parfaitement encastré dans le panneau. Il ne faut ni trop serrer ni insuffisamment serrer.

ES_QUICKFIT: Apriete quickfit hasta que el hombro se descargue con el panel. NO lo sobreapriete ni lo apriete poco.

DE_QUICKFIT: Ziehen Sie den Quickfit fest, bis die Schulter mit der Platte bündig ist. Bitte nicht zu fest oder zu schwach anziehen.

IT_MONTAGGIO RAPIDO: Stringere il montaggio rapido fino a quando la spalla è a filo con il pannello, non stringere troppo o troppo poco.

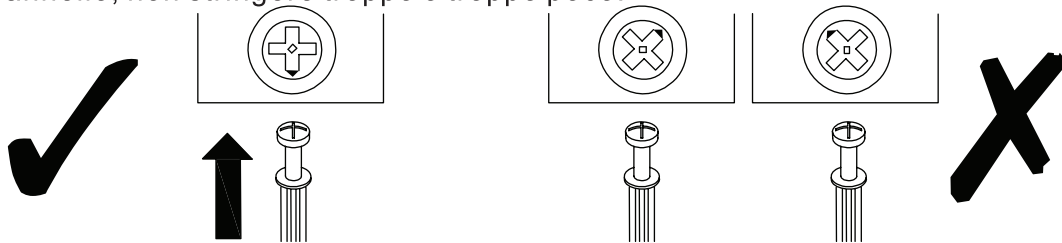

EN_CAM LOCK: When fitting cam lock, ensure starting position is correct before you insert connecting quickfit.

FR_SERRURE BATTEUSE: Avant d'insérer la serrure batteuse, veillez à la bonne orientation avant d'insérer le raccord rapide.

ES_CIERRE DE LA CÁMARA: Cuando instale el cierre de la cámara, asegúrese de que la posición de inicio es correcta antes de que inserte el quickfit conector.

DE_CAM-LOCK: Achten Sie bei der Montage des Cam-Locks auf die richtige Ausgangsposition, bevor Sie den Quickfit einsetzen.

IT_BLOCCAGGIO A CAMMA: Quando si monta il bloccaggio a camma, assicurarsi che la posizione iniziale sia corretta prima di inserire il montaggio rapido di collegamento.

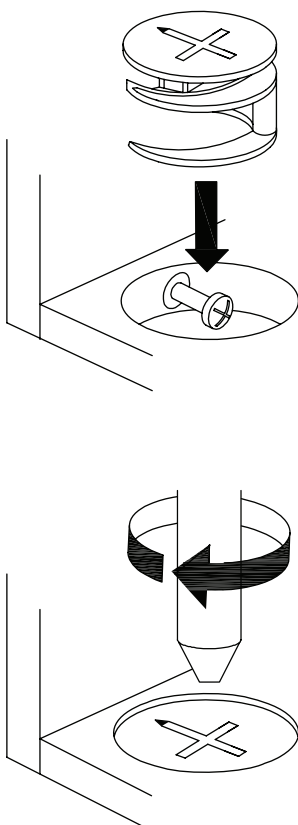

EN_Quickfit head should be in the centre of the cam lock when the two panels are joined.

Cam lock should be inserted before quickfit.

FR_Lorsque les deux panneaux sont assemblés, la tête du raccord rapide doit reposer au centre de la serrure batteuse. Il faut insérer la serrure batteuse avant le raccord rapide.

ES_El cabezal del quickfit debe estar en el centro del cierre de la cámara cuando se unan los dos paneles.

Se debe insertar el cierre de la cámara antes que el quickfit.

DE_Der Quickfit-Kopf sollte sich in der Mitte des Cam-Locks befinden, wenn die beiden Platten zusammengefügt sind.

Der Cam-Lock sollte vor dem Quickfit eingesetzt werden.

IT_La testa del montaggio rapido deve trovarsi al centro del bloccaggio a camma quando i due pannelli sono uniti.

Il Bloccaggio a Camma deve essere inserito prima del montaggio rapido.

EN_Turn cam lock clockwise to tighten.

FR_Faites tourner la serrure batteuse dans le sens des aiguilles d'une montre pour la resserrer.

ES_Gire el cierre de la cámara en sentido horario para apretarlo.

DE_Drehen Sie den Cam-Lock im Uhrzeigersinn, um ihn festzuziehen.

IT_Ruotare il bloccaggio a camma in senso orario per stringere.

DE: Vor dem Einbau die Schrauben in die Löcher stecken und festziehen, aber nicht bis 100%, 70% bis 80% anziehen reicht aus. Schließlich, nachdem alle Schrauben installiert sind, ziehen Sie alle Schrauben auf 100%. Wenn Sie auf diese Probleme stoßen, wie z. B. Fehlausrichtung der Löcher oder Unfähigkeit, bestimmte Teile zu installieren, überprüfen Sie bitte, ob die Schrauben korrekt verwendet werden und passen Sie die Dichtigkeit der Schrauben an.

UK: Before installation, insert the screws into the holes and tighten them, but do not tighten them to 100%, 70% to 80% is sufficient. Finally, after all screws are installed, tighten all screws to 100%. If you encounter these issues, such as if the holes cannot be aligned or some parts cannot be installed, please check if the screws are used correctly and adjust the tightness of the screws.

FR: Insérer la vis dans le trou avant la fin de l'assemblage, serrer la vis, mais ne pas serrer à 100%, 70% ~ 80% est correct. Enfin, une fois que toutes les vis sont bien serrées, toutes les vis sont serrées à 100%. Si vous rencontrez ces problèmes, par exemple si les trous ne sont pas alignés ou si certaines pièces ne peuvent pas être montées, vérifiez que les vis sont utilisées correctement et Ajustez leur serrage.

English

IMPORTANT ! KEEP FOR FUTURE REFERENCE : READ CAREFULLY

- To be assembled by an adult. Assembly must be checked by an adult before use.
- WARNING ! Keep all screws, small parts and plastic bags out of the reach of children.
- Properly identify all parts before assembling.
- Anchor unit to stud or wall.
- Always use on a level, even surface.
- Avoid the risk of fire by not placing furniture near sources of ignition or hot items.
- DO NOT place hot or cold items directly onto the surface.
- DO NOT place the item next to a radiator or direct sunlight.
- DO NOT allow children to climb on unit.
- DO NOT put the product in a humid environment.

Deutsch

WICHTIG ! ZUM SPÄTEREN NACHSCHLAGEN AUFBEWAHREN: SORGFÄLTIG LESEN

- Muss von einem Erwachsenen zusammengebaut werden. Der Zusammenbau muss vor der Benutzung von einem Erwachsenen überprüft werden.
- WARNUNG! Bewahren Sie alle Schrauben, Kleinteile und Plastikbeutel außerhalb der Reichweite von Kindern auf.
- Kennzeichnen Sie vor dem Zusammenbau alle Teile ordnungsgemäß.
- Verankern Sie das Gerät an einem Ständer oder einer Wand.
- Benutzen Sie das Gerät immer auf einer ebenen, geraden Fläche.
- Vermeiden Sie das Risiko eines Brandes, indem Sie die Möbel nicht in der Nähe von Zündquellen oder heißen Gegenständen aufstellen.
- Stellen Sie KEINE heißen oder kalten Gegenstände direkt auf die Oberfläche.
- Stellen Sie das Gerät NICHT in der Nähe eines Heizkörpers oder direkter Sonneneinstrahlung auf.
- Erlauben Sie Kindern NICHT, auf das Gerät zu klettern.
- Stellen Sie das Gerät NICHT in einer feuchten Umgebung auf.

Français

IMPORTANT ! CONSERVER POUR RÉFÉRENCE ULTÉRIEURE : LIRE ATTENTIVEMENT

- A assembler par un adulte. Le montage doit être vérifié par un adulte avant utilisation.
- ATTENTION ! Conservez toutes les vis, les petites pièces et les sacs en plastique hors de portée des enfants.
- Identifiez correctement toutes les pièces avant de les assembler.
- Fixer l'appareil à un montant ou à un mur.
- Utilisez toujours l'appareil sur une surface plane et uniforme.
- Évitez les risques d'incendie en ne plaçant pas les meubles à proximité de sources d'inflammation ou d'objets chauds.
- NE PAS placer d'objets chauds ou froids directement sur la surface.
- NE PAS placer l'appareil à côté d'un radiateur ou de la lumière directe du soleil.
- NE PAS laisser les enfants grimper sur l'appareil.
- NE PAS placer le produit dans un environnement humide.

Italiano

IMPORTANTE! CONSERVARE PER RIFERIMENTO FUTURO: LEGGERE ATTENTAMENTE

- Deve essere assemblato da un adulto. L'assemblaggio deve essere controllato da un adulto prima dell'uso.
- AVVERTENZA ! Tenere tutte le viti, le piccole parti e i sacchetti di plastica fuori dalla portata dei bambini.
- Identificare correttamente tutte le parti prima dell'assemblaggio.
- Ancorare l'unità a un pilastro o a una parete.
- Utilizzare sempre su una superficie piana e uniforme.
- Evitare il rischio di incendio non collocando i mobili vicino a fonti di accensione o ad oggetti caldi.
- NON collocare oggetti caldi o freddi direttamente sulla superficie.
- NON collocare l'apparecchio vicino a un termosifone o alla luce diretta del sole.
- NON permettere ai bambini di arrampicarsi sull'unità.
- NON collocare il prodotto in un ambiente umido.

Español

¡ IMPORTANTE ! CONSERVELO PARA FUTURAS CONSULTAS: LEA ATENTAMENTE

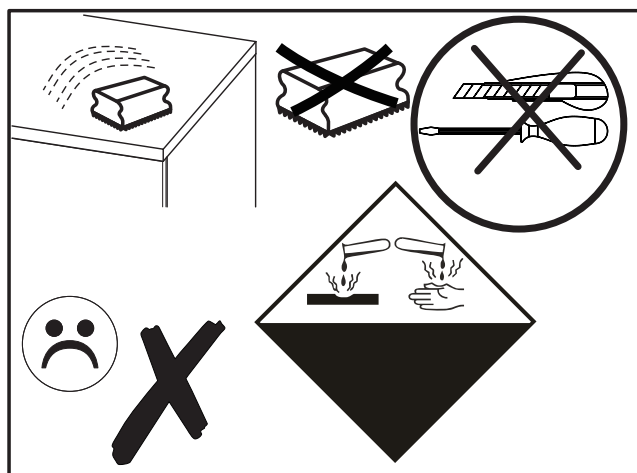
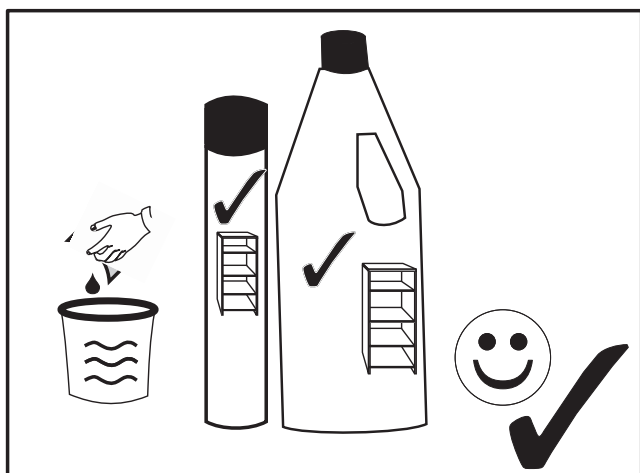

- Debe montarlo un adulto. El montaje debe ser comprobado por un adulto antes del uso.
- ADVERTENCIA Mantenga todos los tornillos, piezas pequeñas y bolsas de plástico fuera del alcance de los niños.
- Identifique correctamente todas las piezas antes del montaje.
- Ancle la unidad a un montante o pared.
- Utilí celo siempre sobre una superficie plana y nivelada.
- Evite el riesgo de incendio no colocando los muebles cerca de fuentes de ignición o artículos calientes.
- NO coloque objetos calientes o fríos directamente sobre la superficie.
- NO coloque el mueble cerca de un radiador o de la luz solar directa.
- NO permita que los niños se suban a la unidad.
- NO coloque el producto en un ambiente húmedo.



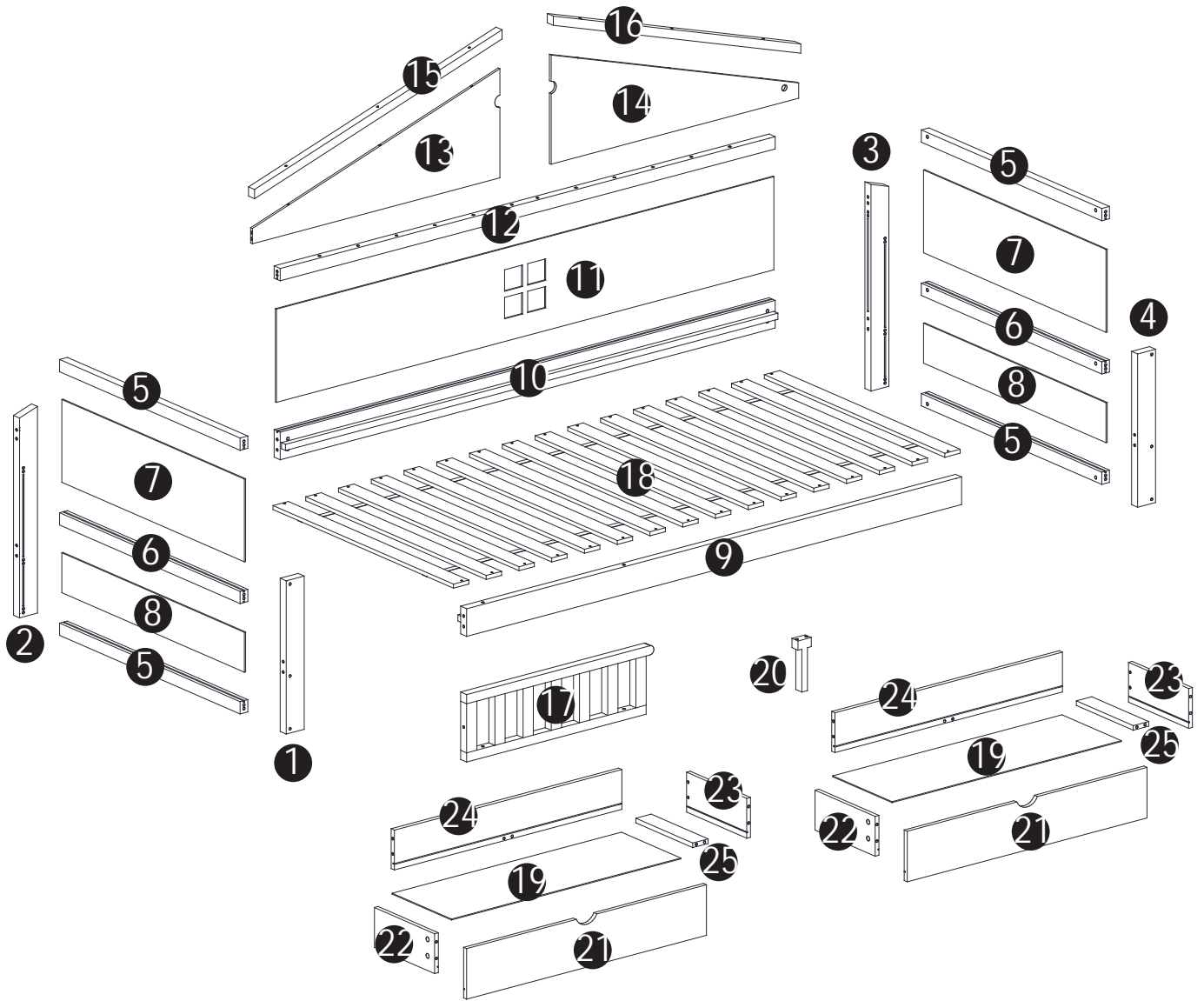

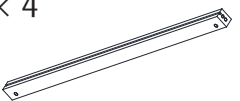
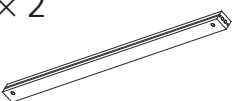

Detail I Ansicht

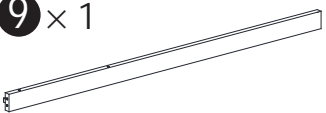
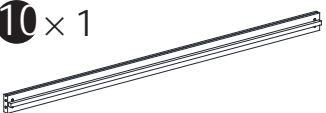
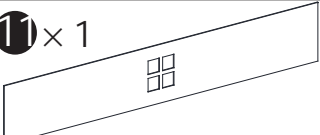
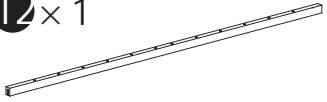
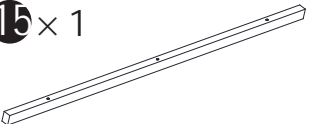
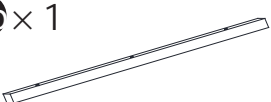
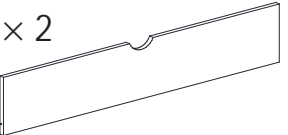



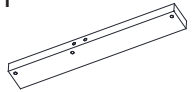
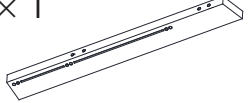
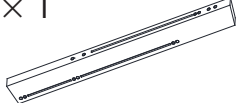
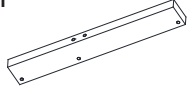
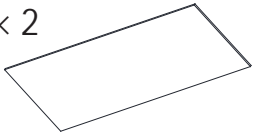
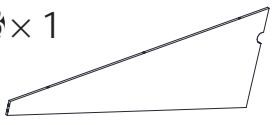

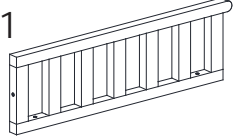
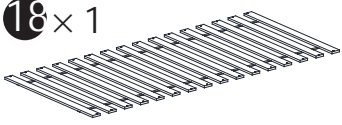

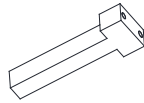
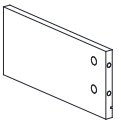
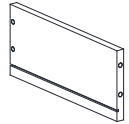
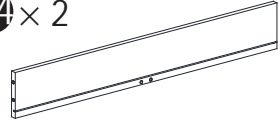
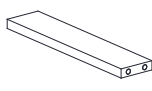





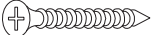
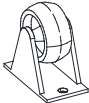

N623P371628

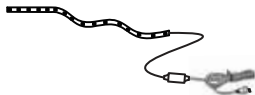
5 × 4 	6 × 2 	8 × 2 	9 × 1 
10 × 1 	11 × 1 	12 × 1 	15 × 1 
16 × 1 	21 × 2 		

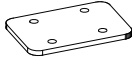
N623P371629



1 × 1 	2 × 1 	3 × 1 	4 × 1 
7 × 2 	13 × 1 	14 × 1 	17 × 1 
18 × 1 	19 × 2 	20 × 1 	22 × 2 
23 × 2 	24 × 2 	25 × 2 	

N623P371629

A  M6*110mm (12PCS)	B  M6*70mm (12PCS)	C  Φ 6*60mm (3PCS)	D  (1PC)
E  (24PCS)	F  Φ 4*30mm (40PCS)	G  (8PCS)	H  Φ 8*30mm (26PCS)
I  Φ 6*50mm (2PCS)	J  (1PC)	K  (8PCS)	L  (3PCS)
M  Φ 3.5*14mm (36PCS)	N  M4 (1PC)	O  (1PC)	P  Φ 6*35mm (26PCS)
Q  Φ 15*11mm (26PCS)	R  (2PCS)		

VERWENDEN SIE KEINE POWER TOOLS, um dieses Produkt zusammenzubauen!



Do not use power tools to assemble this product!

A 	B 
M6*110mm	M6*70mm

DE:Bitte beachten Sie, dass die Formen der Schrauben A und B ähnlich sind. Bitte installieren Sie entsprechend der Anleitung und unterscheiden Sie sie!

UK:Please note that the shapes of screws A and B are similar. Please install according to the instructions and distinguish them!

FR:Notez que les vis A et B ont des formes similaires. Veuillez les installer en suivant les instructions pour les séparer!

F 	M 
Φ 4*30mm	Φ 3.5*14mm

DE:Bitte beachten Sie, dass die Formen der Schrauben F und M ähnlich sind. Bitte installieren Sie entsprechend der Anleitung und unterscheiden Sie sie!



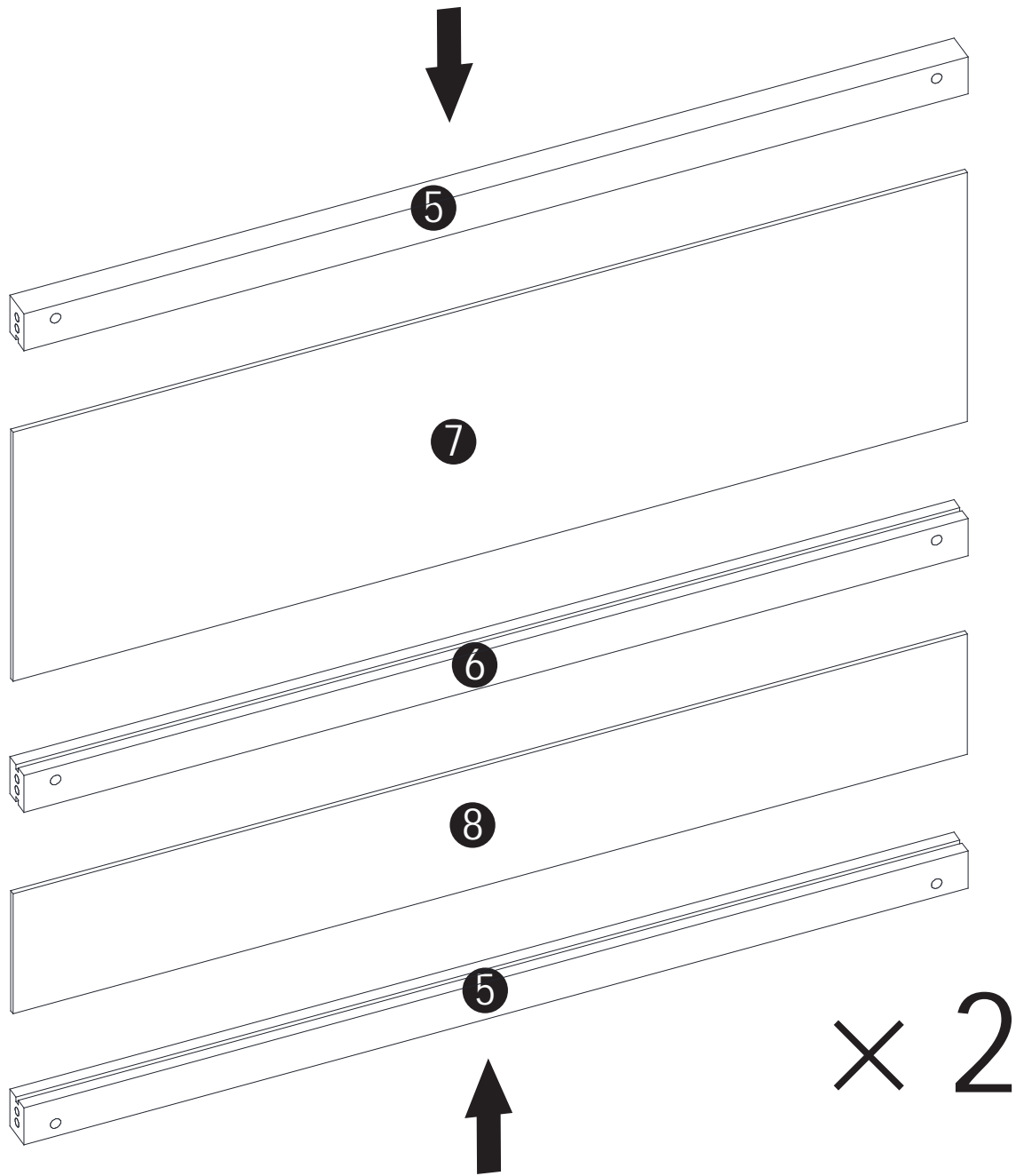

UK:Please note that the shapes of screws F and M are similar. Please install according to the instructions and distinguish them!

FR:Notez que les vis F et M ont des formes similaires. Veuillez les installer en suivant les instructions pour les séparer!



SCHRITT 1 :





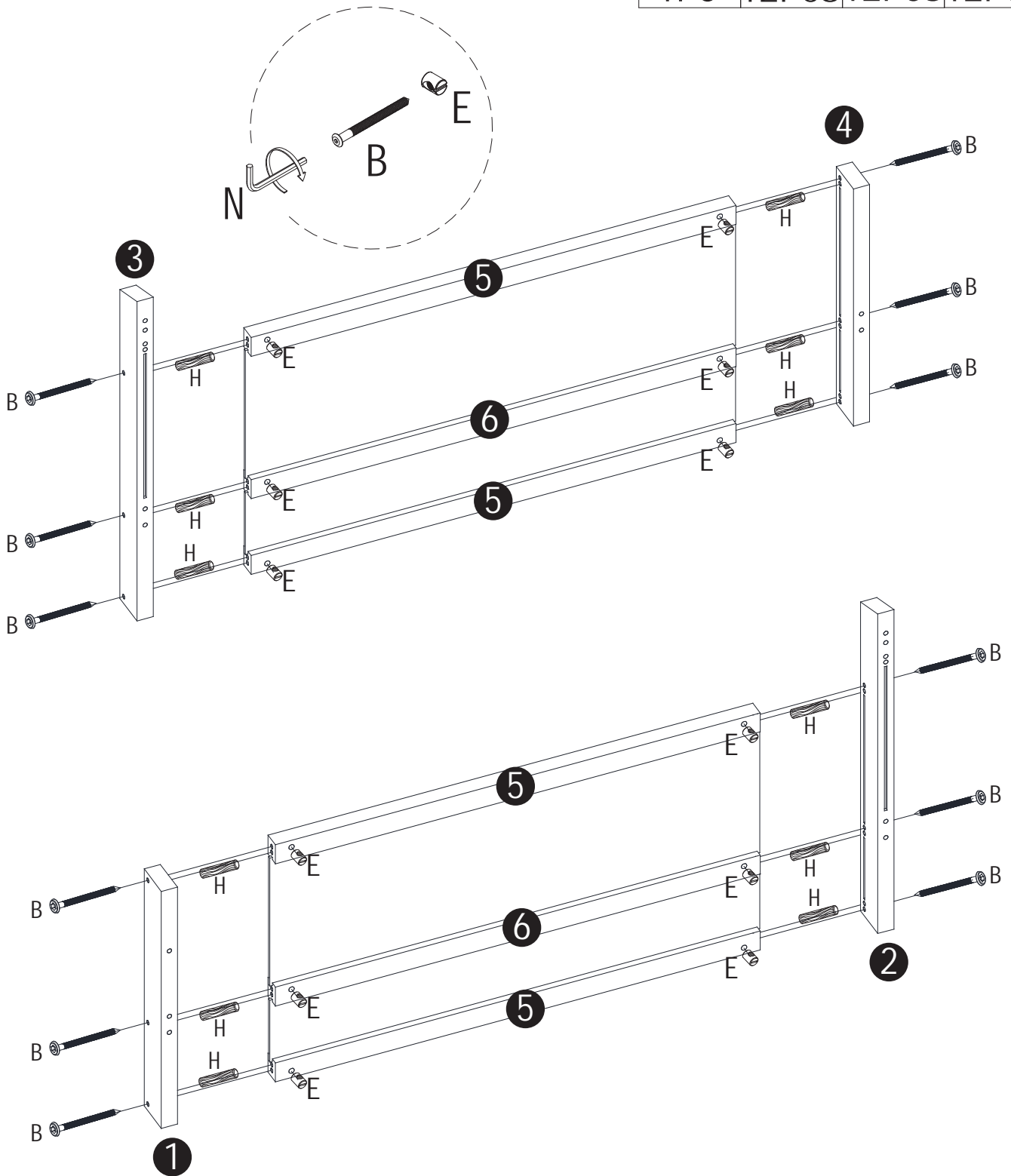

SCHRITT 2 :

N	E	B	H
			
1PC	12PCS	12PCS	12PCS



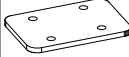

A		B	
M6*110mm		M6*70mm (12pcs)	

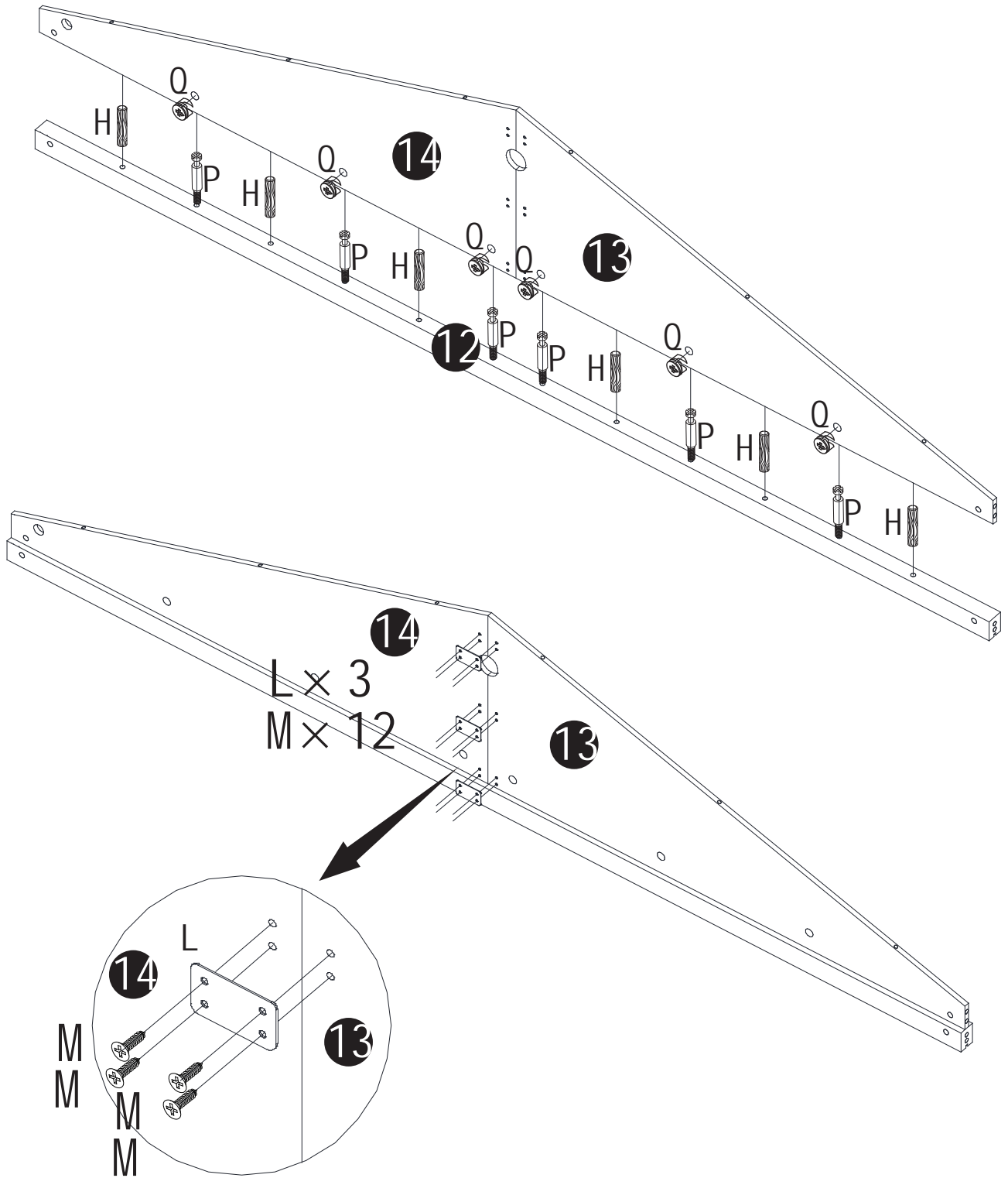

SCHRITT 3 :

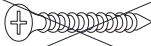
H	Q	M	L	O	P
					
6PCS	6PCS	12PCS	3PCS	1PC	6PCS





F	M
	
Φ 4*30mm	Φ 3.5*14mm (12pcs)



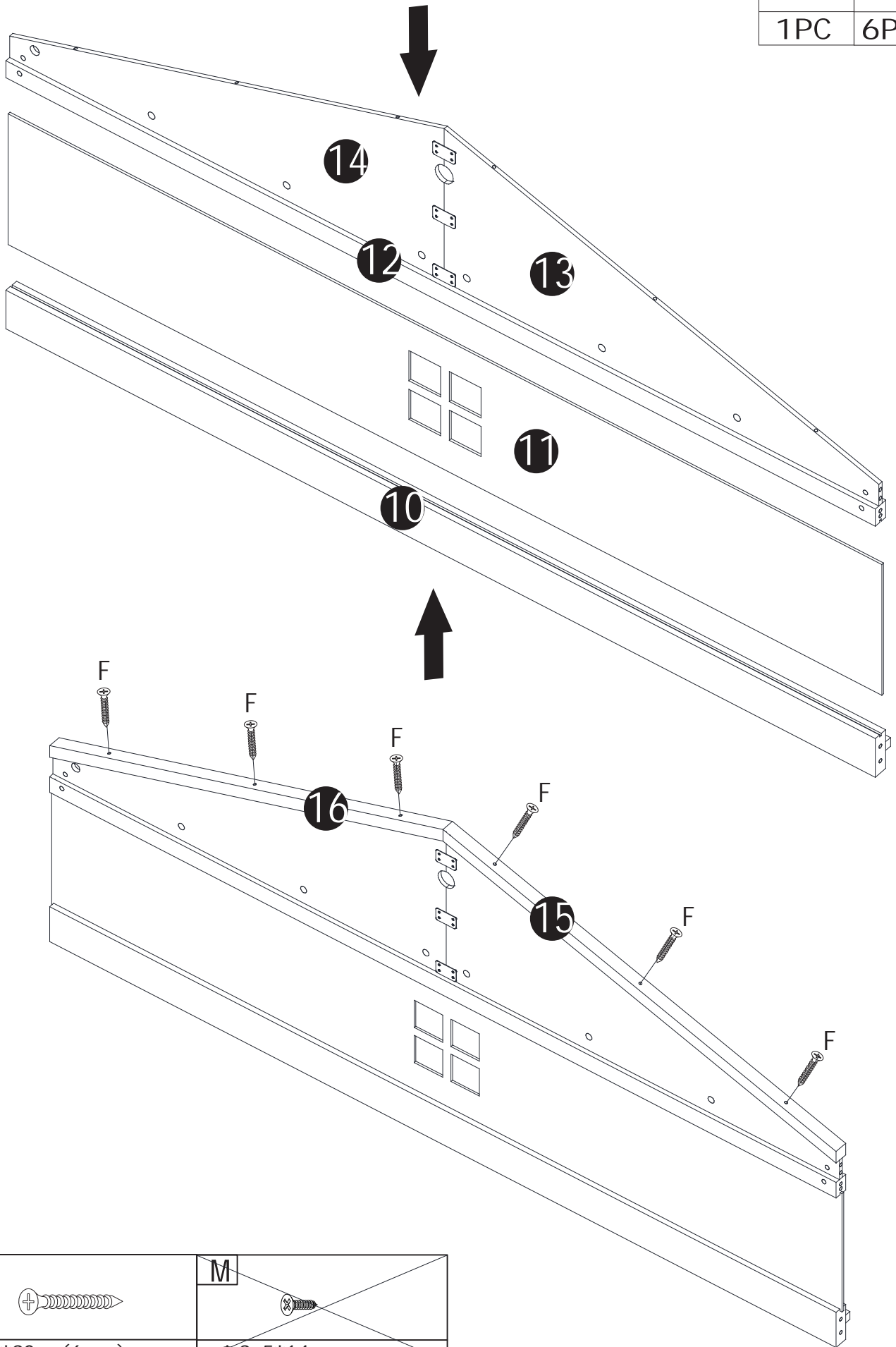

SCHRITT 4 :

0	F
	
1PC	6PCS



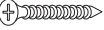

F	M
	
Φ 4*30mm (6pcs)	Φ 3.5*14mm

SCHRITT 5 :

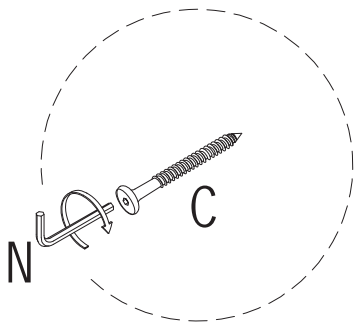
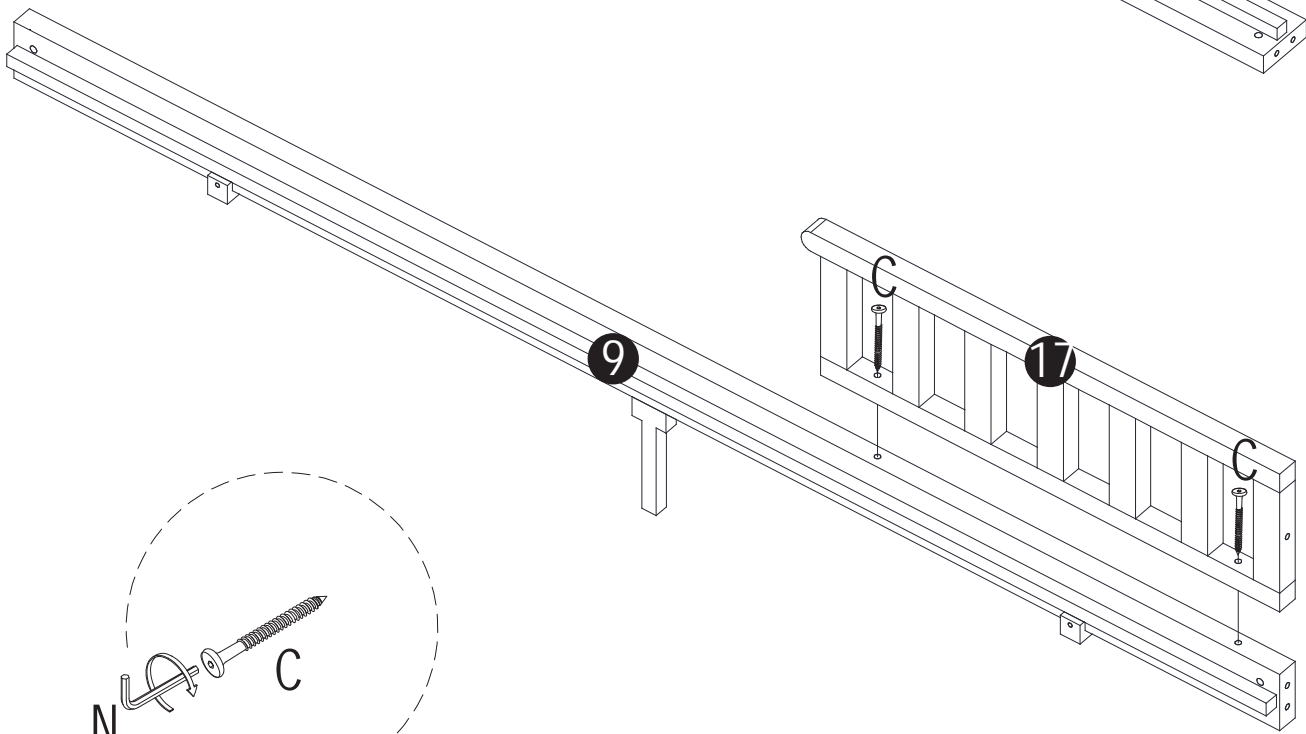
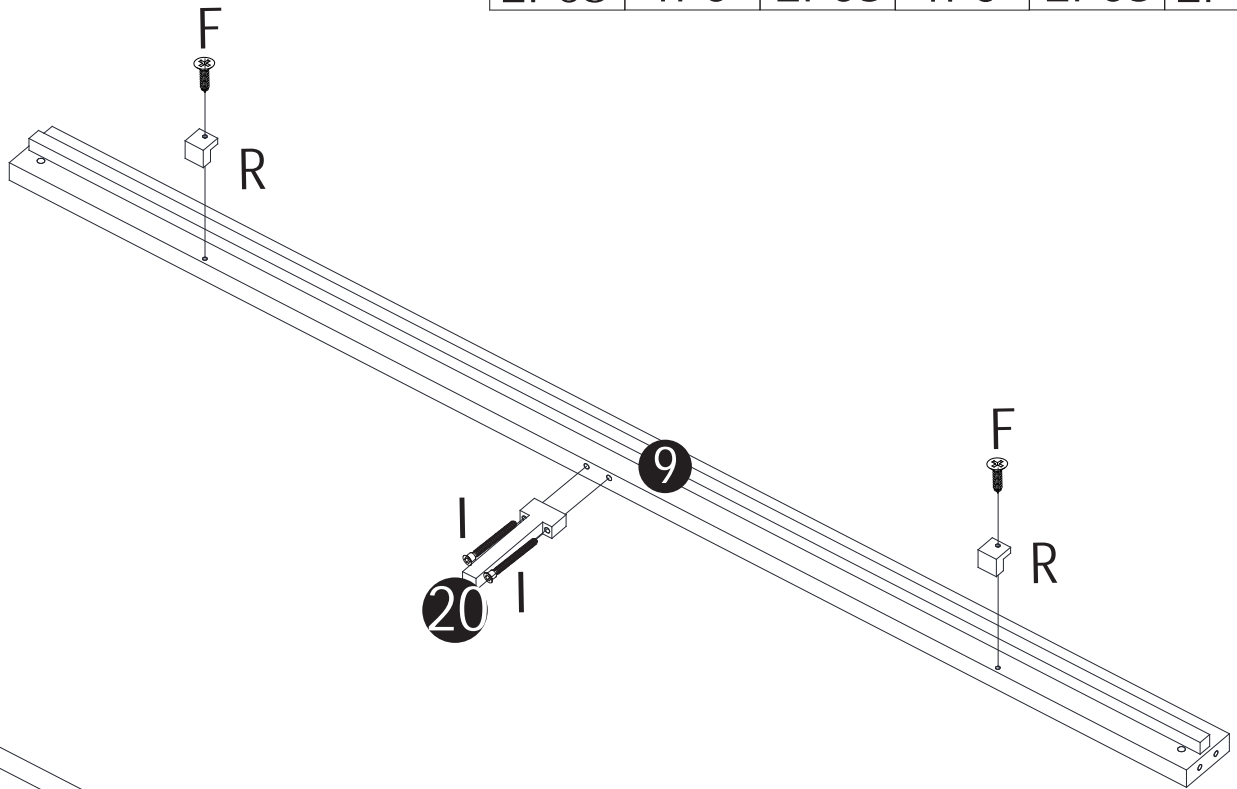
C	N	R	O	I	F
					
2PCS	1PC	2PCS	1PC	2PCS	2PCS





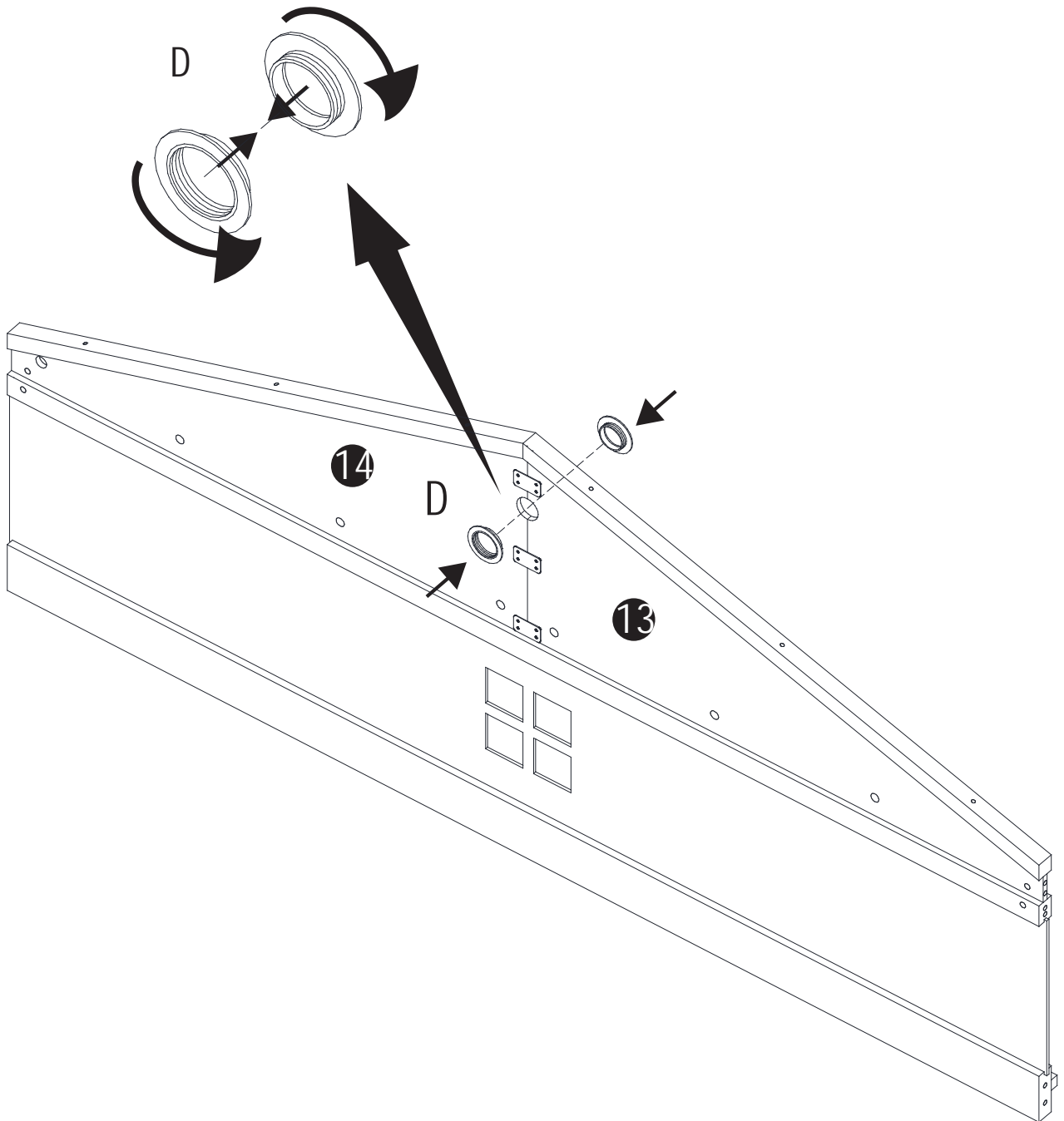

F	M
	
Φ 4*30mm (2pcs)	Φ 3.5*14mm

SCHRITT 6 :

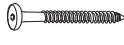

D
1PC

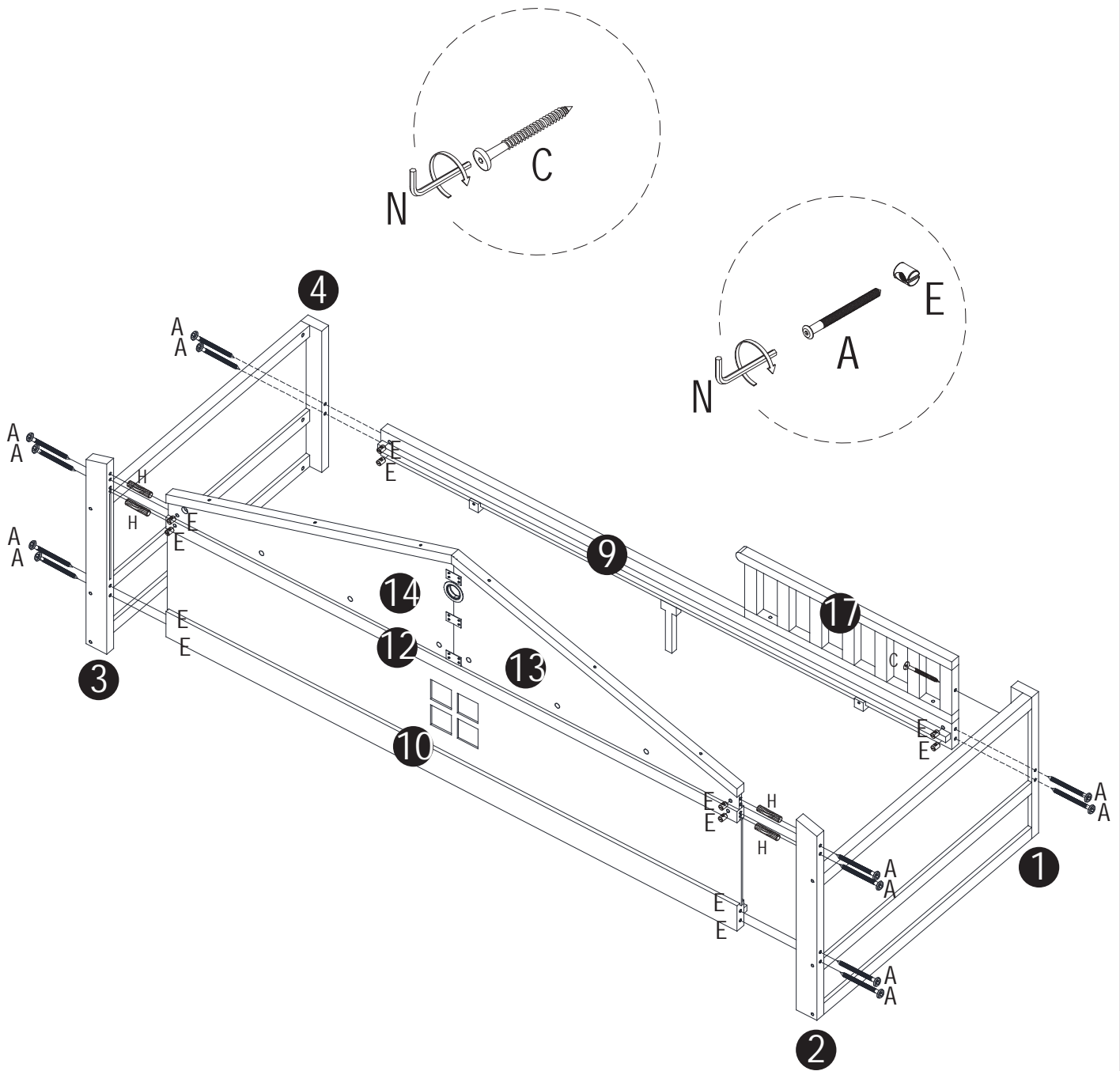

SCHRITT 7 :

C	N	E	A	H
				
1PC	1PC	12PCS	12PCS	4PCS



A		B	
M6*110mm(20pcs)		M6*70mm	

SCHRITT 8 :

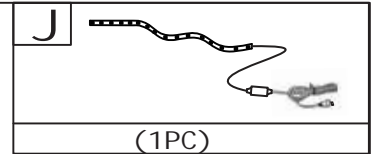



EN:Scan to download App control the Led light.

DE:Scannen, um die App zum Steuern des LED-Lichts herunterzuladen

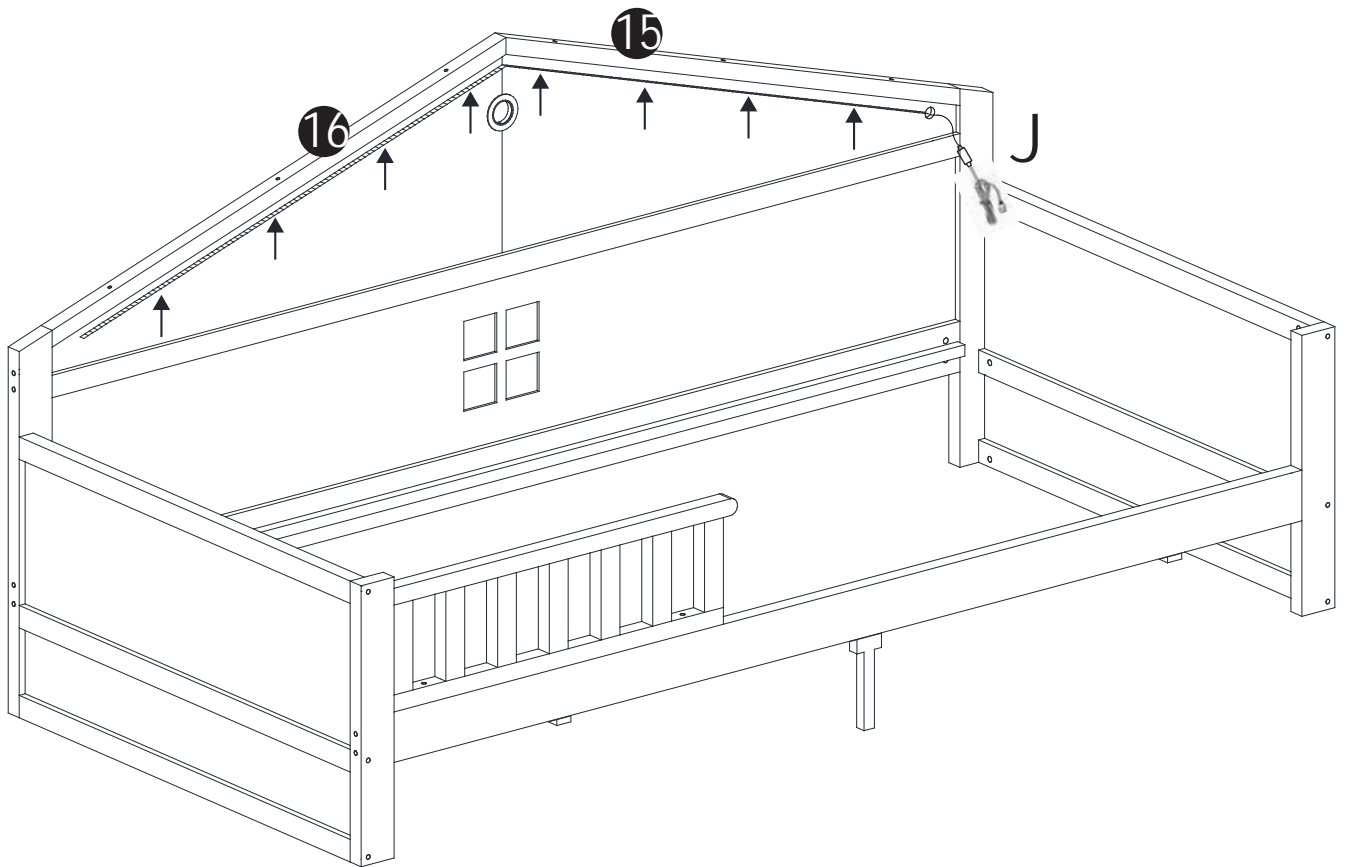
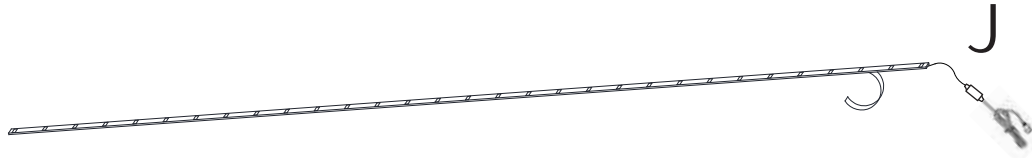

FR:Scanner pour télécharger App contrôler la lumière Led.

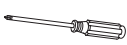

SCHRITT 9 :

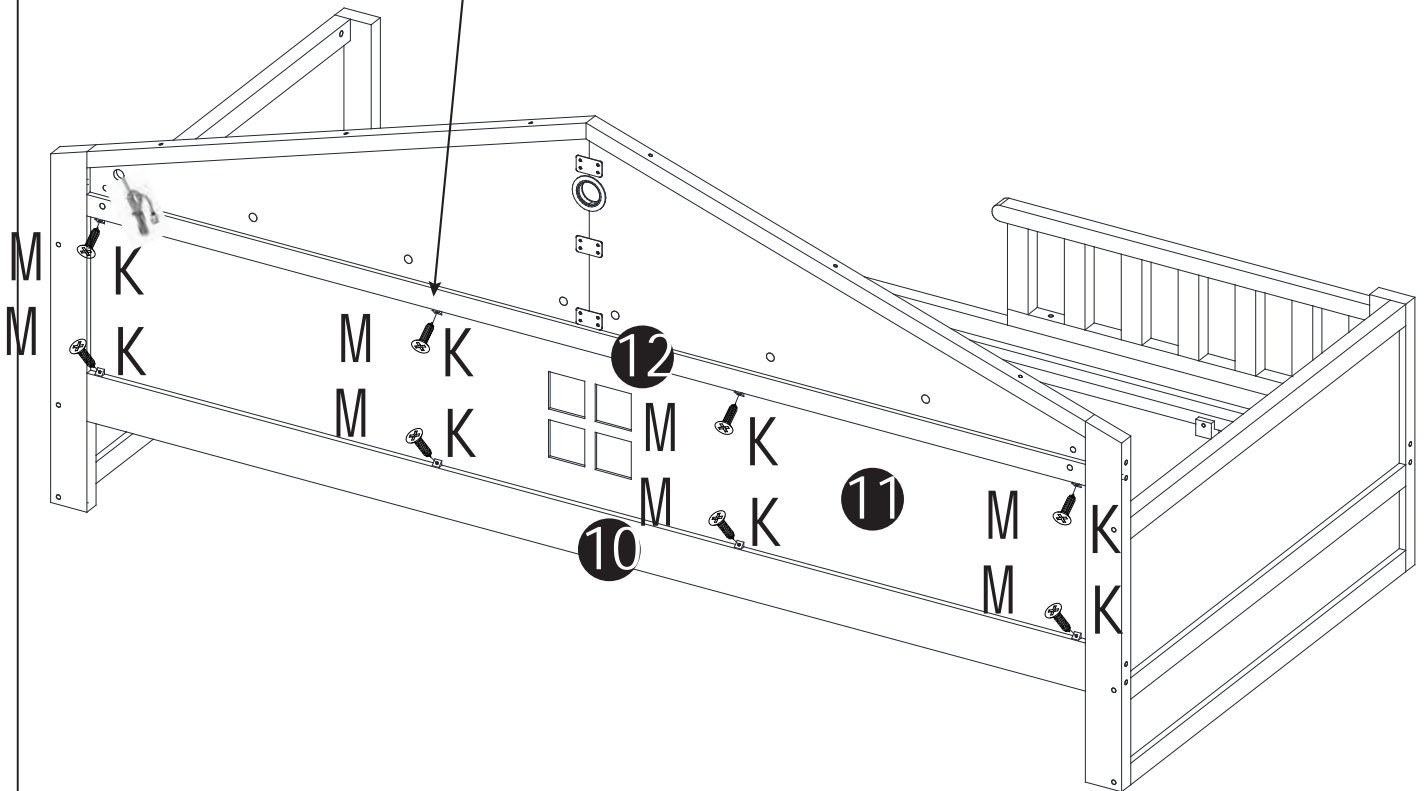
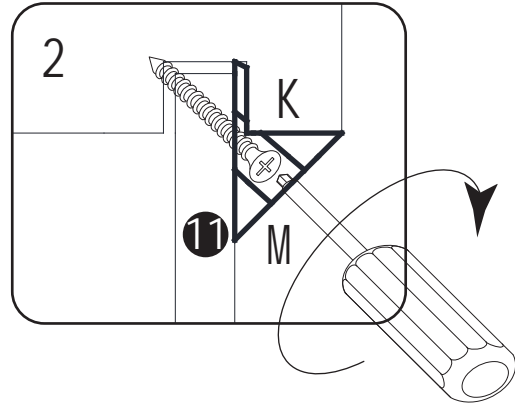
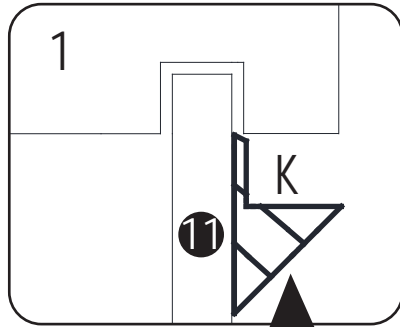
O	M	K
		
1PC	8PCS	8PCS





F	M
	
Φ 4*30mm	Φ 3.5*14mm (8pcs)

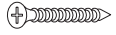

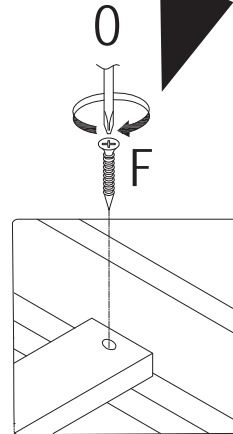
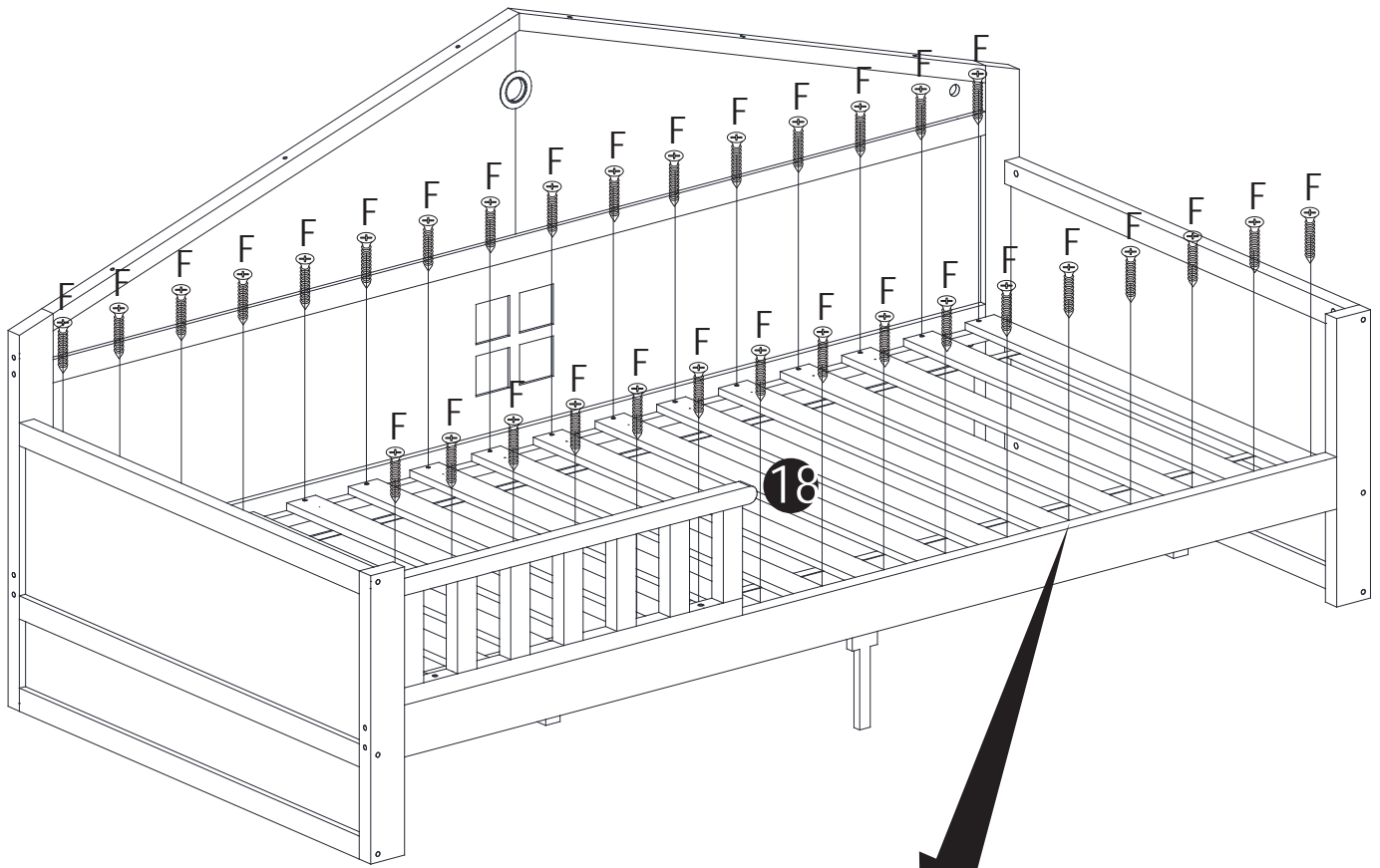

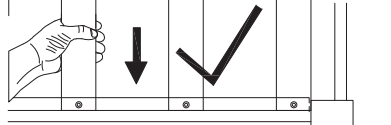
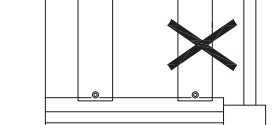

SCHRITT 10 :

0	F
	
1PC	32PCS





<p>F</p>  <p>Φ 4*30mm (32pcs)</p>	<p>M</p>  <p>Φ 3.5*14mm</p>		
---	---	--	---

SCHRITT 11:

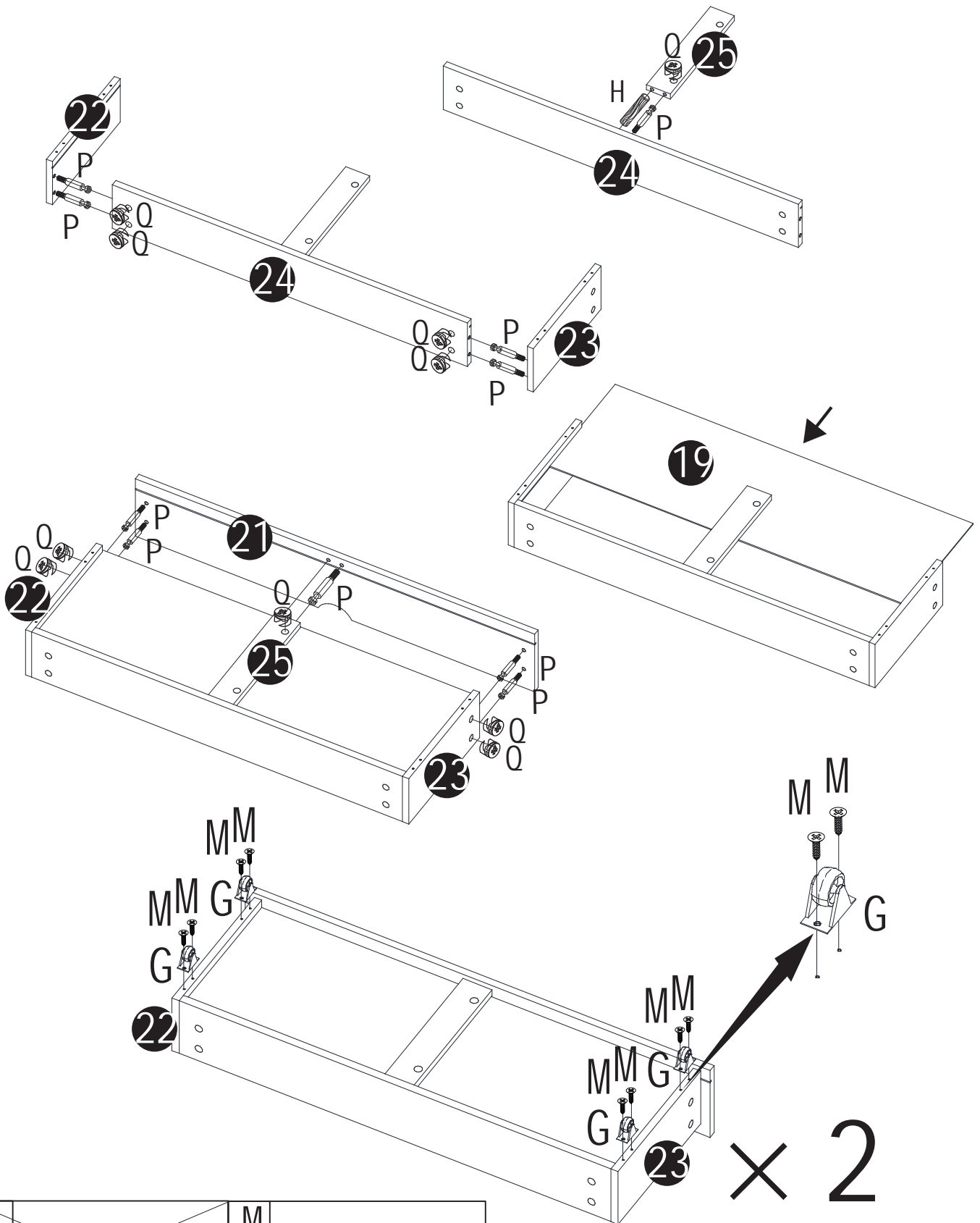
G	H	M	Q	P	O
					
8PCS	4PCS	16PCS	20PCS	20PCS	1PC

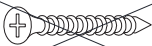

F	M
	
Φ 4*30mm	Φ 3.5*14mm (16pcs)

SCHRITT 12:

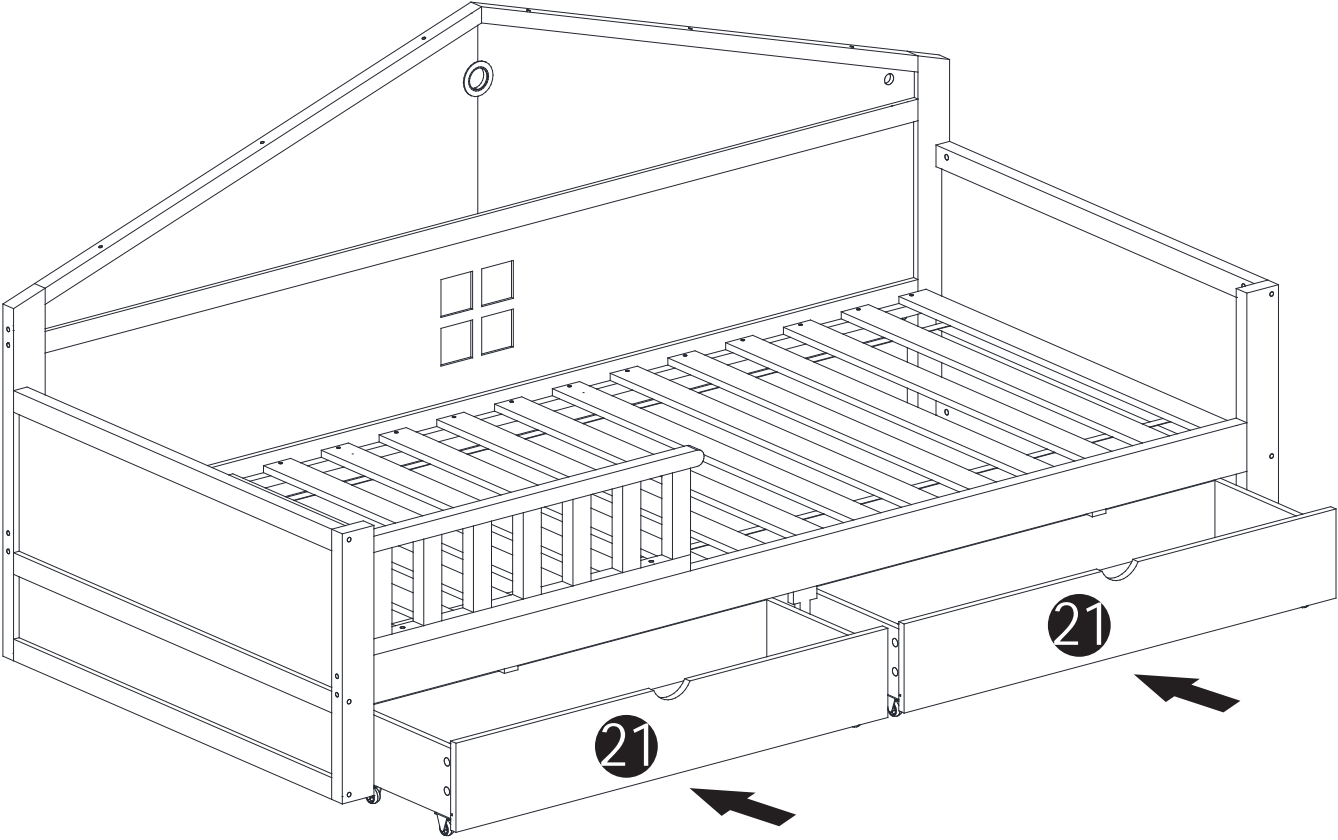



Certificate of Conformity

Certificate No. : SIT190523591401E
Product : LED Strip Light
Model : 2835, 5050, 3528, 3014, 2110, 335, 5630
Trade Mark : N/A
Applicant : SHENZHEN KEWANG PHOTOELECTRIC CO., LTD.
Address : Floor 2, Build A, ChuangFu Industrial Park, AiQun Road, ShiYan Street, BaoAn District, ShenZhen
Manufacturer : SHENZHEN KEWANG PHOTOELECTRIC CO., LTD.
Address : Floor 2, Build A, ChuangFu Industrial Park, AiQun Road, ShiYan Street, BaoAn District, ShenZhen

The above products have been tested by us with listed standards and found in compliance with the council EMC 2014/30/EU. It is possible to use CE marking to demonstrate the compliance with this EMC.

Test standards:	Report(s) Number	Issued By	Issued Date
EN 55015:2013+A1:2015 EN 62493:2015 EN 61547:2009 EN 61000-3-2:2014 EN 61000-3-3:2013	SIT190523591401ER	SIT	May 30, 2019

This certificate of conformity is not transferable and based on an evaluation of a sample of the above mentioned product.



Authorized Signer: _____

Department Manager

Date: May 30, 2019

Shenzhen SIT Testing Technology Co., Ltd.

Hotline: 400-6633-940

Tel: (86)-0755-29173399

Fax: (86)-0755-29179933

Http://www.sit-cert.com



Certification of Compliance

Under FCC Supplier's Declaration of Conformity

Certificate No.:SIT190523591401F

Applicant : SHENZHEN KEWANG PHOTOELECTRIC CO., LTD.
Address : Floor 2, Build A, ChuangFu Industrial Park, AiQun Road, ShiYan Street, BaoAn District, ShenZhen
Manufacturer : SHENZHEN KEWANG PHOTOELECTRIC CO., LTD.
Address : Floor 2, Build A, ChuangFu Industrial Park, AiQun Road, ShiYan Street, BaoAn District, ShenZhen
Product Name : LED Strip Light
Model No. : 2835, 5050, 3528, 3014, 2110, 335, 5630
Trade Name : N/A
FCC Rules : FCC Part 15 Subpart B
Report No. : SIT190523591401FR

Based upon the referenced test report(s), sample of the above product have been found to comply with the FCC rules listed on this certificate.

This device complies with Part 15 of the FCC Rules. Operation is subject to the following two conditions: (1) this device may not cause harmful interference, and (2) this device must accept any interference received, including interference that may cause undesired operation.



Authorized Signer: _____

Department Manager

Date: May 30, 2019

Shenzhen SIT Testing Technology Co., Ltd.

Email:Info@sitcert.com

Tel: (86)-0755-29173399

Fax: (86)-0755-29179933

Http://www.sit-cert.com



Certificate of Conformity

Certificate No. : SIT190523591401S
Product : LED Strip Light
Model : 2835, 5050, 3528, 3014, 2110, 335, 5630
Trade Mark : N/A
Applicant : SHENZHEN KEWANG PHOTOELECTRIC CO., LTD.
Address : Floor 2, Build A, ChuangFu Industrial Park, AiQun Road, ShiYan Street, BaoAn District, ShenZhen
Manufacturer : SHENZHEN KEWANG PHOTOELECTRIC CO., LTD.
Address : Floor 2, Build A, ChuangFu Industrial Park, AiQun Road, ShiYan Street, BaoAn District, ShenZhen

The above products have been tested by us with listed standards and found in compliance with the council RoHS 2011/65/EU and revise directive(EU)2015/863.

It is possible to use RoHS marking to demonstrate the compliance with this RoHS.

Test standards:	Report(s) Number	Issued By	Issued Date
IEC 62321-3-1:2013 IEC 62321-5:2013 IEC 62321-6:2015 IEC 62321-7-1:2015 IEC 62321-4:2013+AMD1:2017 IEC 62321:2008 ANNEX C	SIT190523591401SR	SIT	May 30, 2019

This certificate of conformity is not transferable and based on an evaluation of a sample of the above mentioned product.

RoHS

Authorized Signer: _____



Department Manager

Date: May 30, 2019

Shenzhen SIT Testing Technology Co., Ltd.

Hotline:400-6633-940

Tel: (86)-0755-29173399

Fax: (86)-0755-29179933

Http://www.sit-cert.com